



US 20160184009A1

(19) **United States**  
(12) **Patent Application Publication**  
**Rosenblatt et al.**

(10) **Pub. No.: US 2016/0184009 A1**  
(43) **Pub. Date: Jun. 30, 2016**

(54) **HEMOSTASIS AND TRANSECTION OF TISSUE**

a continuation of application No. 11/770,714, filed on Jun. 28, 2007, now Pat. No. 7,806,894.

(71) Applicant: **New England Association of Gynecologic Laparoscopists, LLP**, West Newton, MA (US)

(60) Provisional application No. 60/806,031, filed on Jun. 28, 2006.

**Publication Classification**

(72) Inventors: **Peter L. Rosenblatt**, West Newton, MA (US); **Anthony J. DiSciullo**, Westwood, MA (US)

(51) **Int. Cl.**  
*A61B 18/14* (2006.01)

(73) Assignee: **New England Association of Gynecologic Laparoscopists, LLP**, West Newton, MA (US)

(52) **U.S. Cl.**  
CPC ... *A61B 18/1492* (2013.01); *A61B 2018/00559* (2013.01)

(21) Appl. No.: **14/816,436**

(57) **ABSTRACT**

(22) Filed: **Aug. 3, 2015**

A laparoscopic cautery instrument may include an elongate shaft, a handle coupled to the shaft and moveable with respect to the shaft, an insulation ring, and a monopolar cautery wire. A laparoscopic cautery instrument may include an elongate shaft, a handle coupled to the shaft and moveable with respect to the shaft, a monopolar cautery wire, and an electrical conductor.

**Related U.S. Application Data**

(63) Continuation-in-part of application No. 12/897,736, filed on Oct. 4, 2010, now Pat. No. 9,095,369, which is

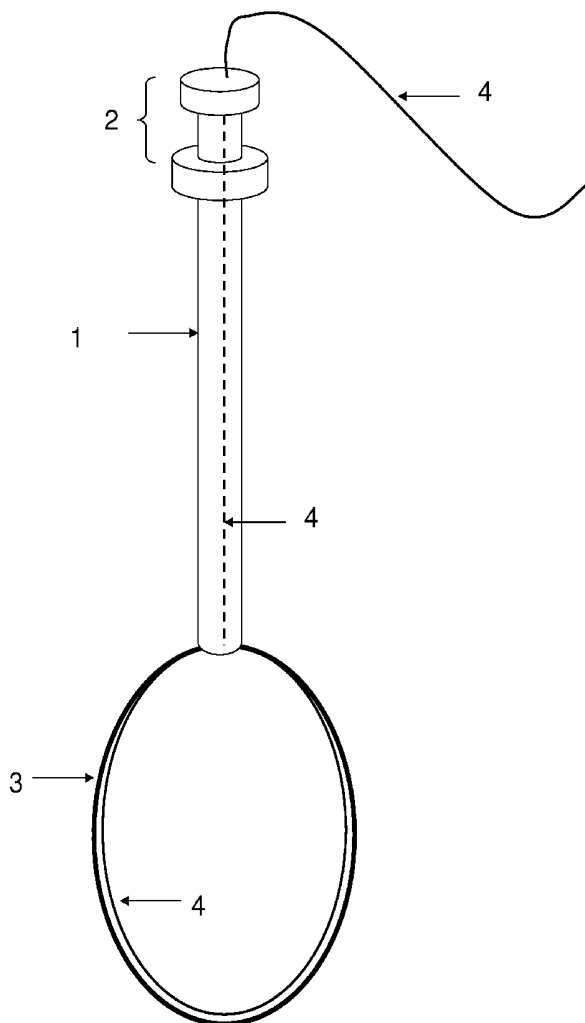

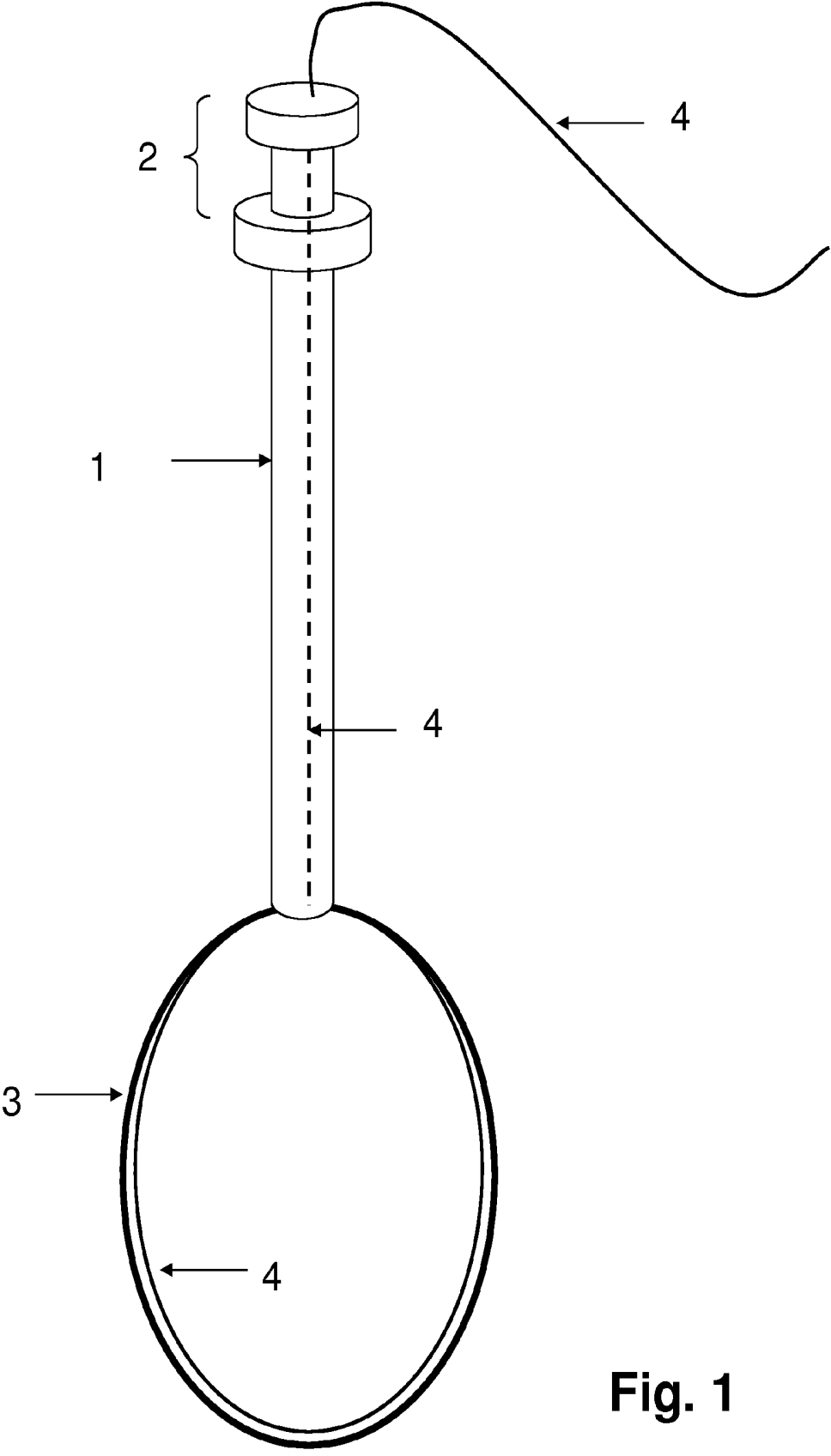
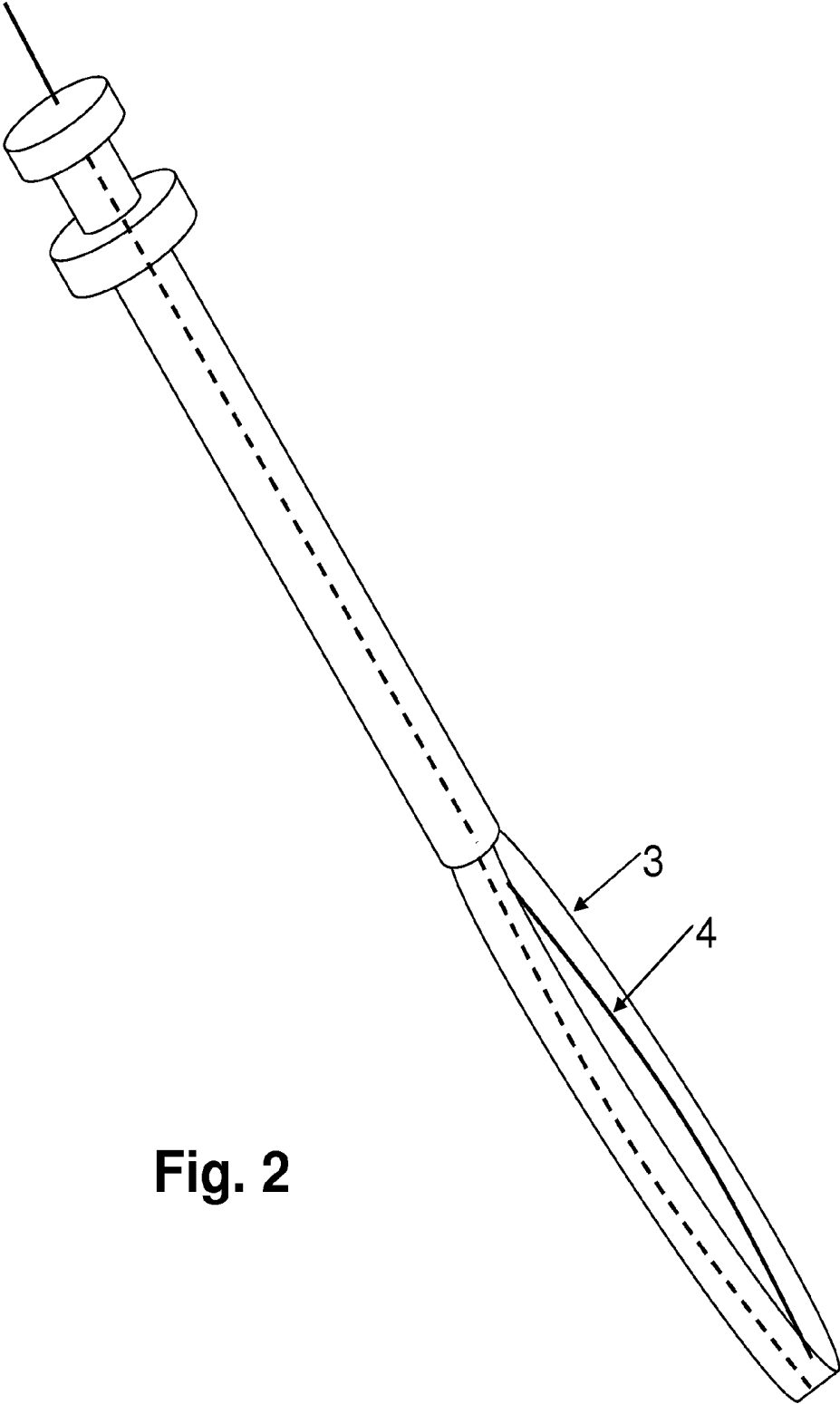
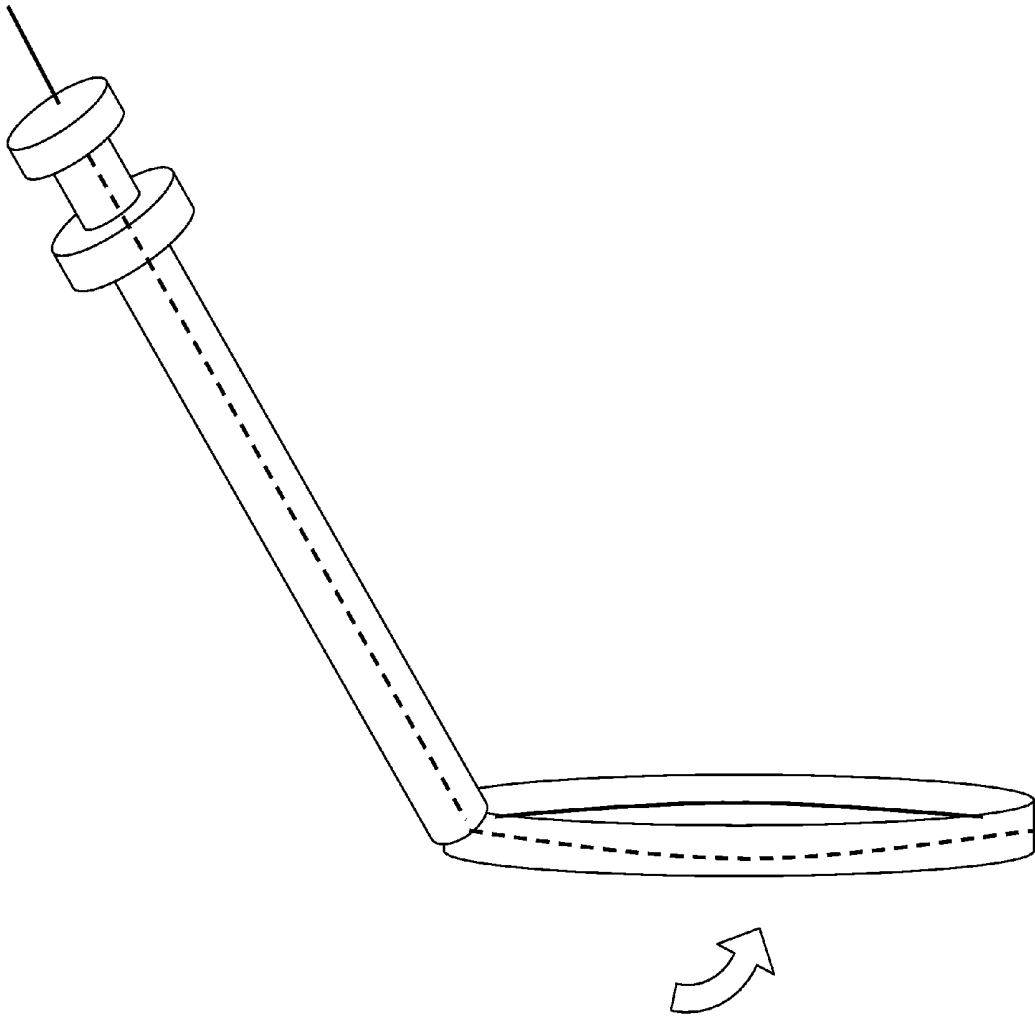

Fig. 1



**Fig. 2**



**Fig. 3**

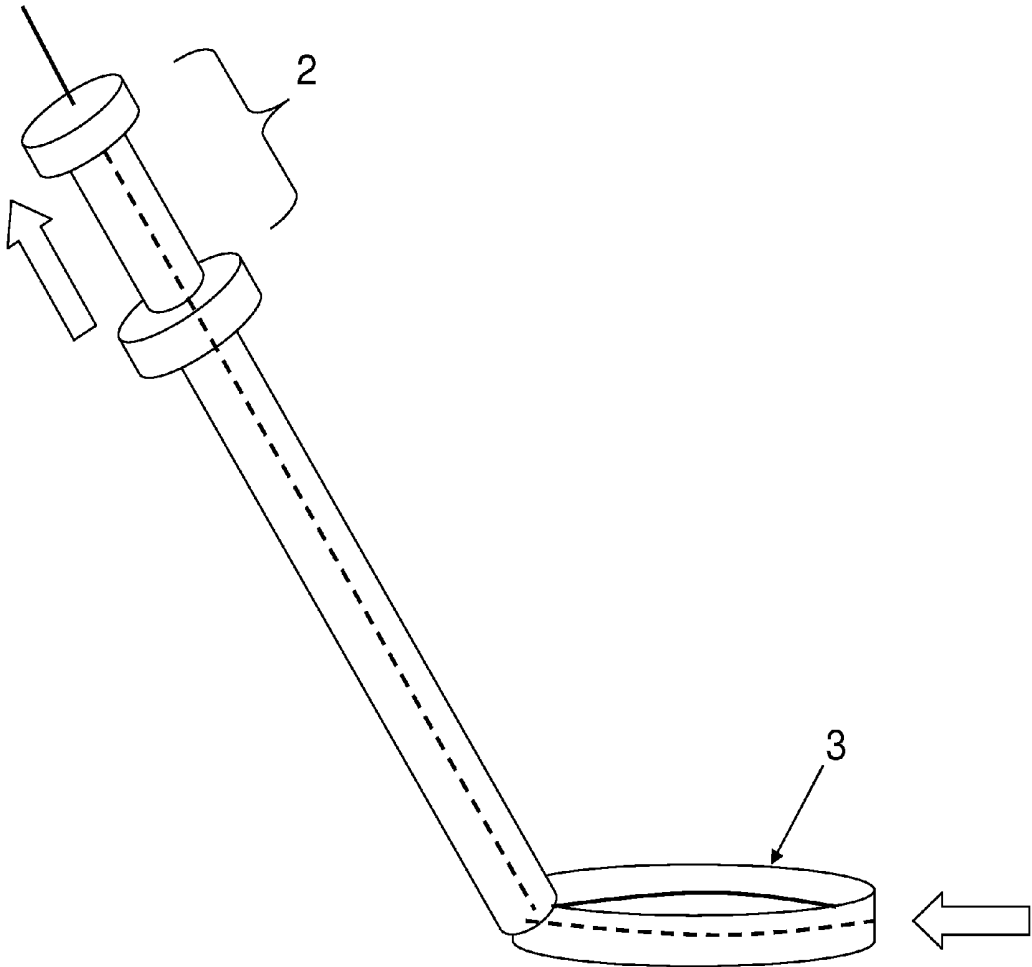

Fig. 4

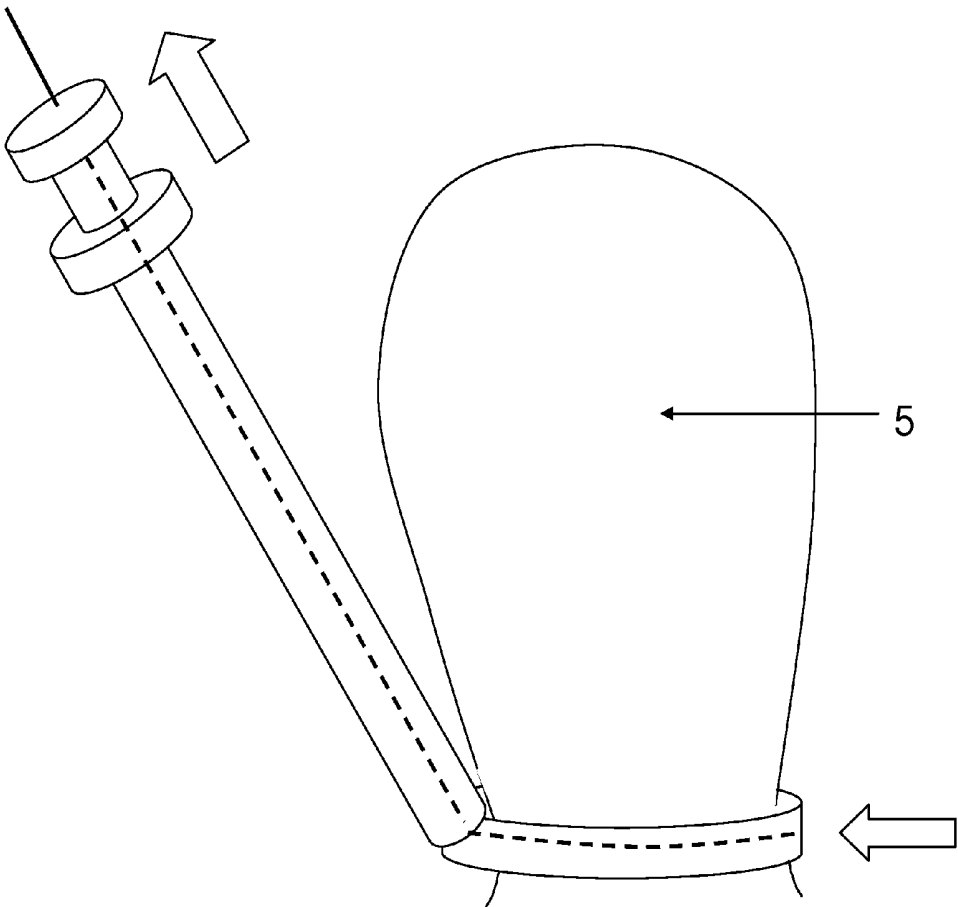

Fig. 5

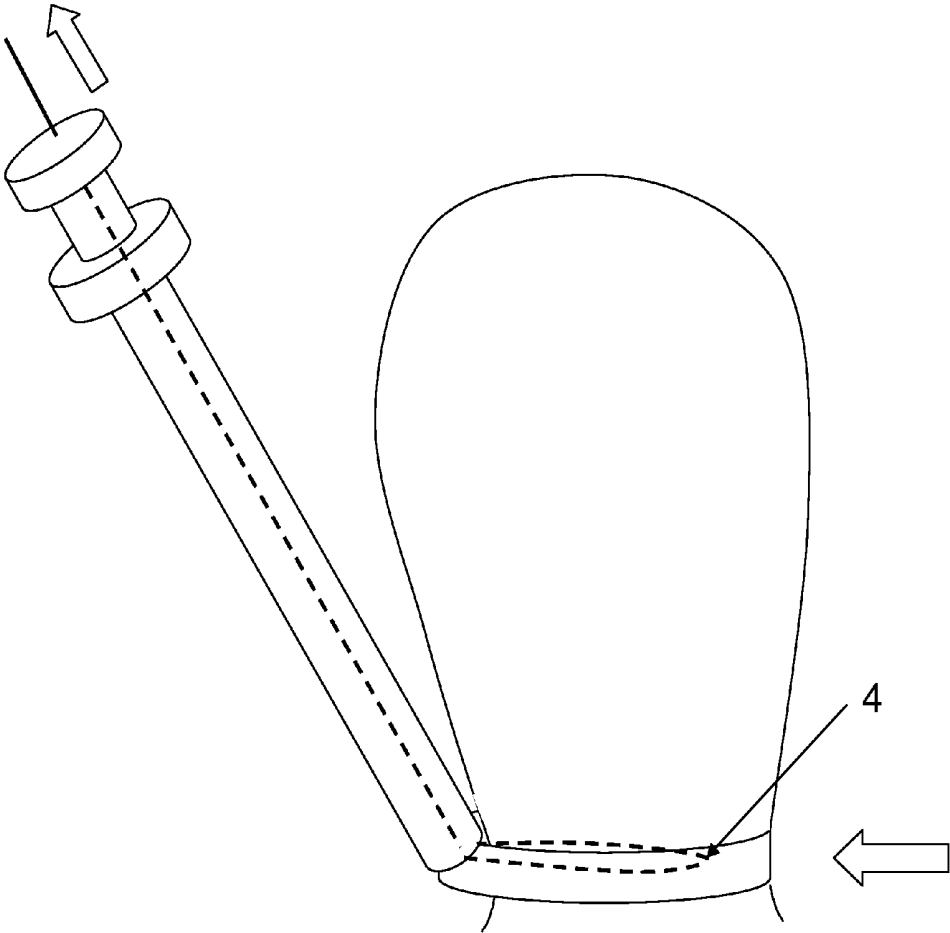

Fig. 6

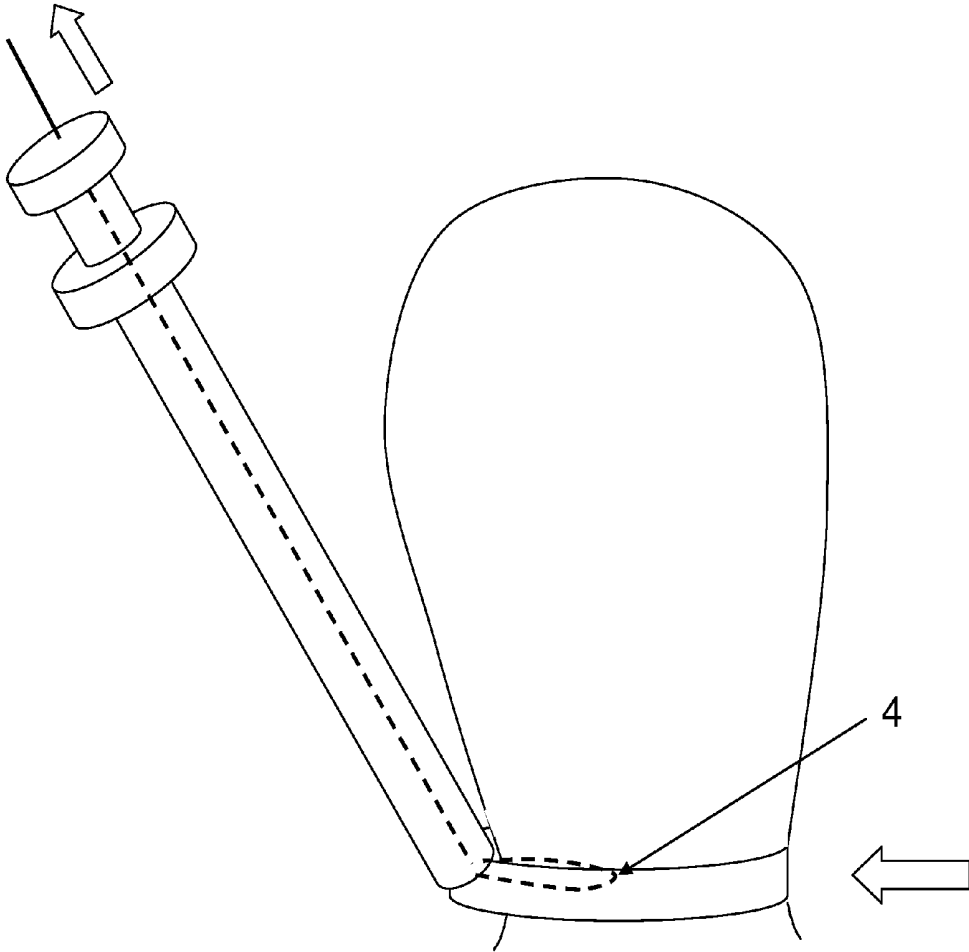
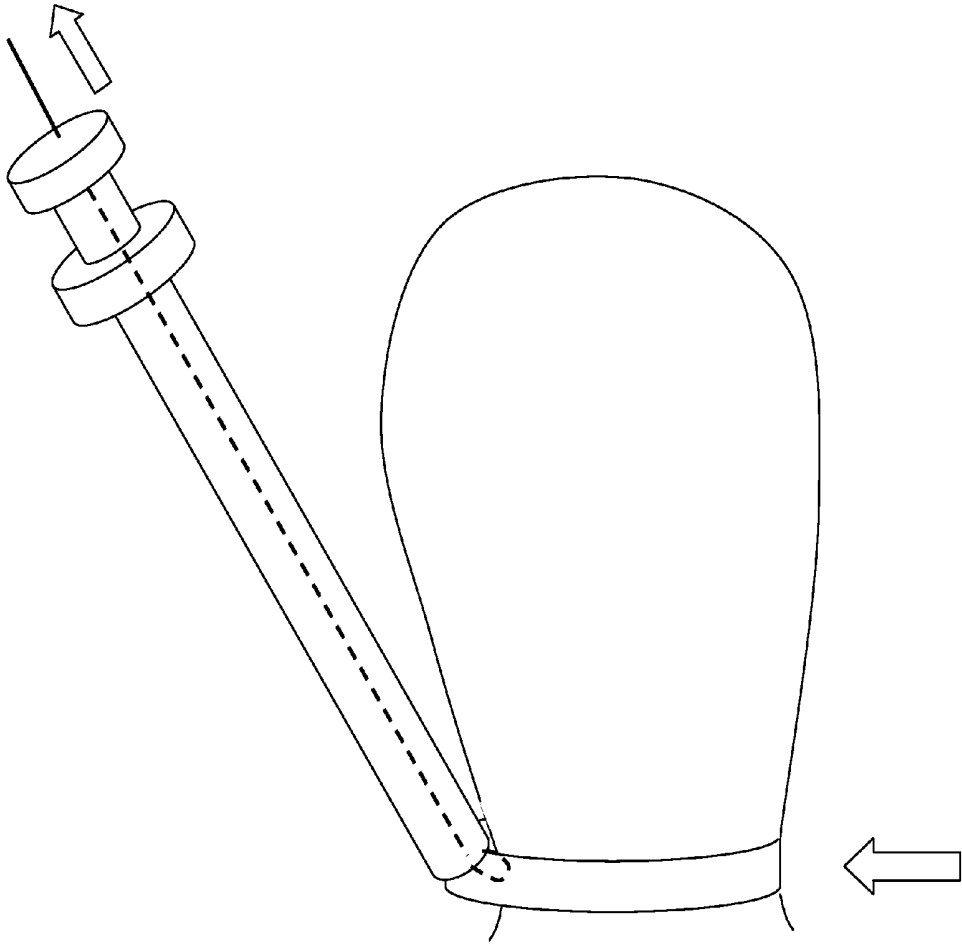

Fig. 7



**Fig. 8**

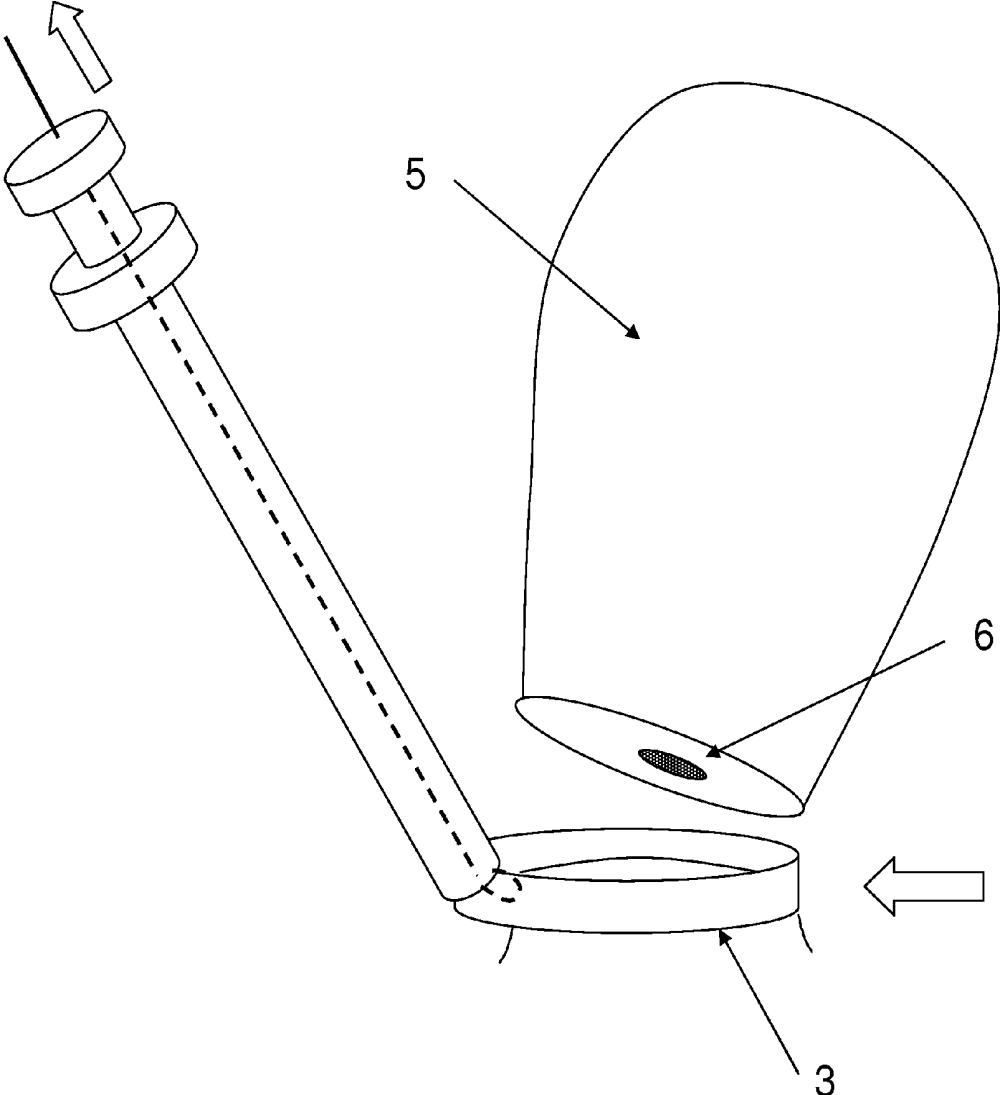

Fig. 9

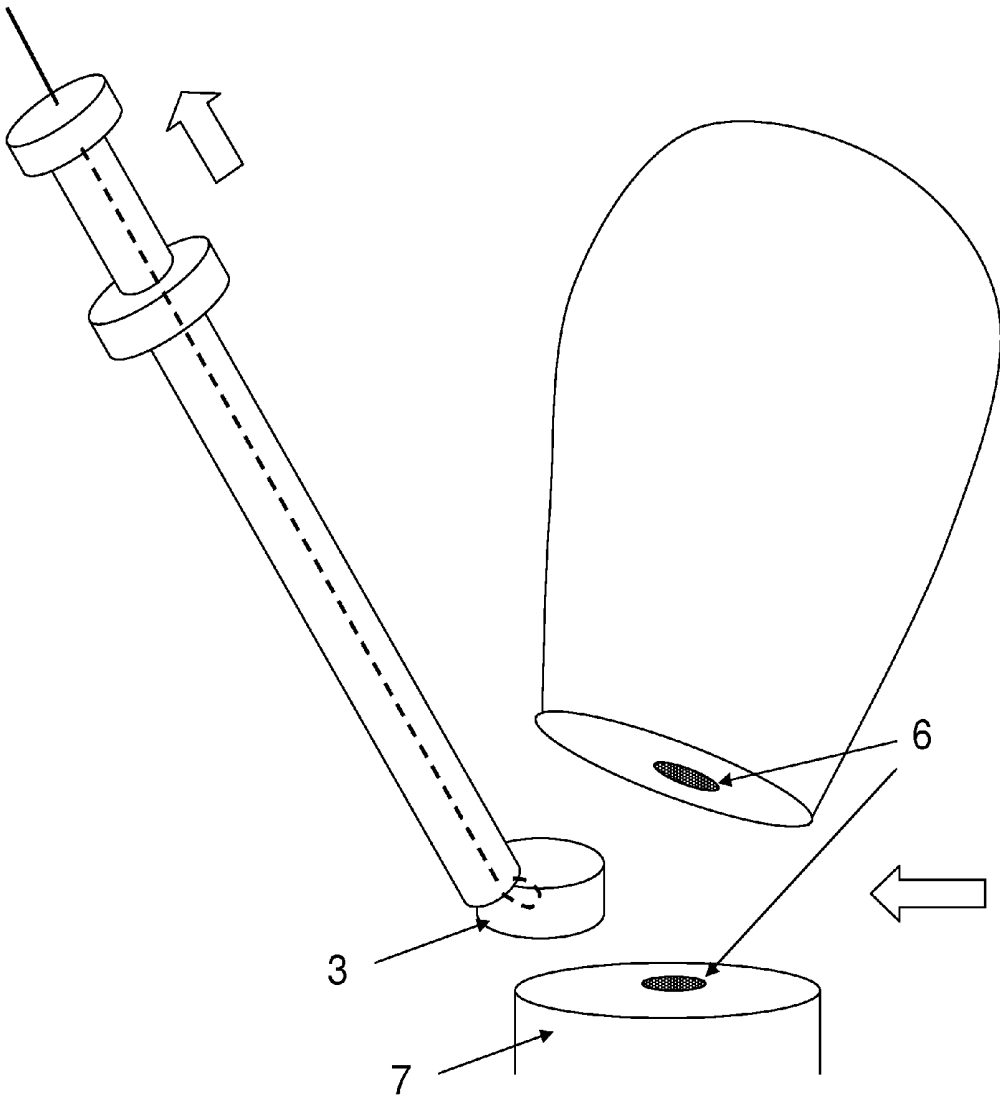

Fig. 10

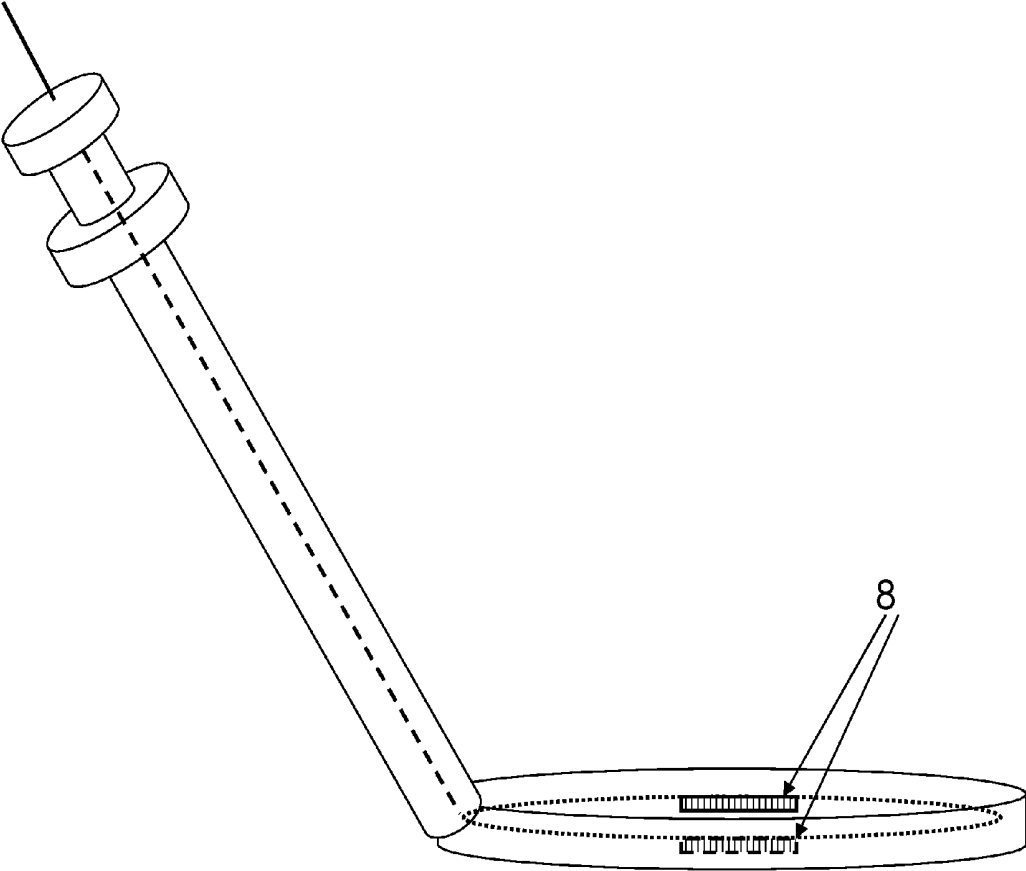

Fig. 11

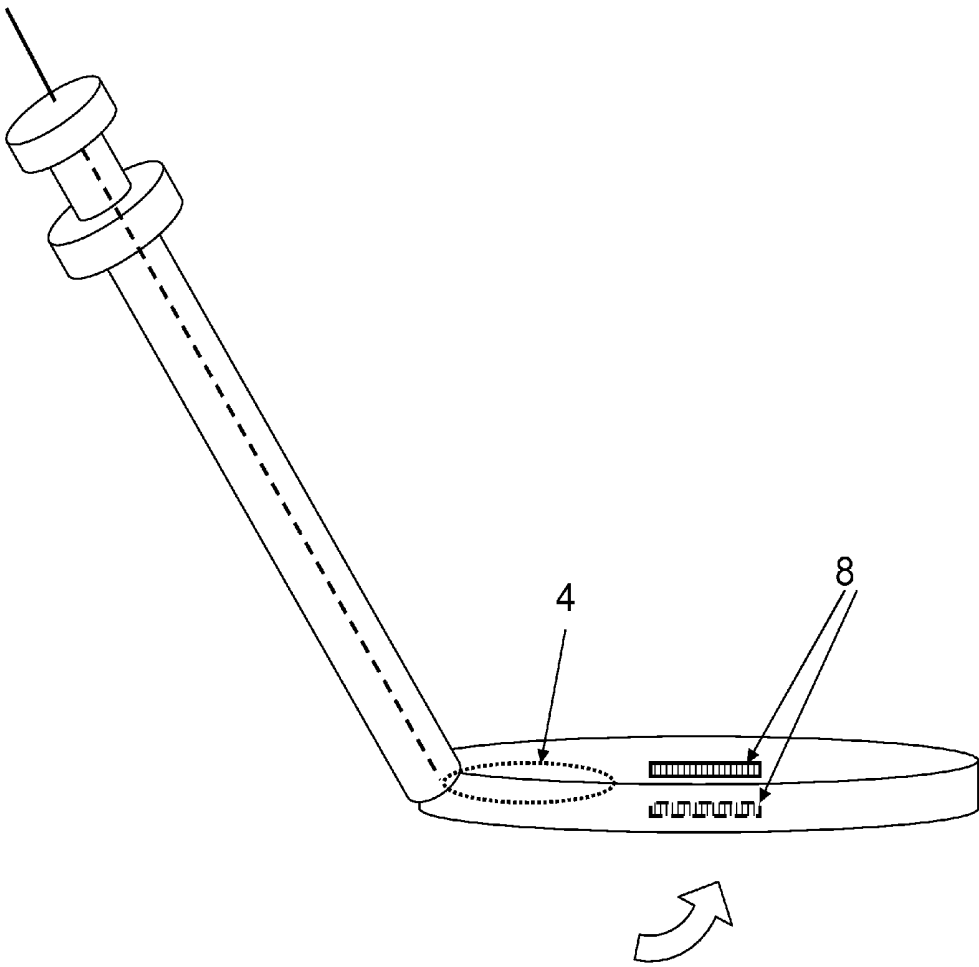
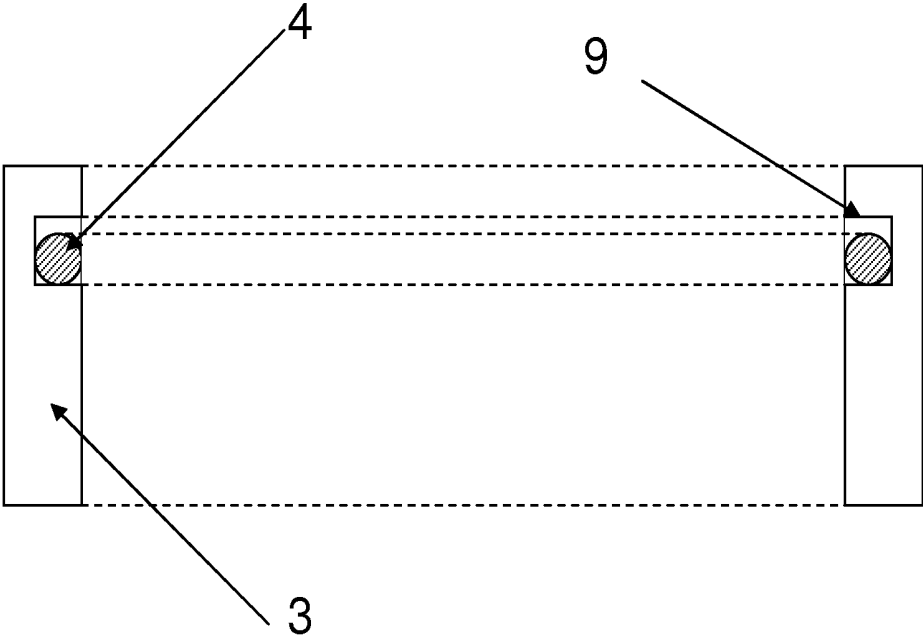
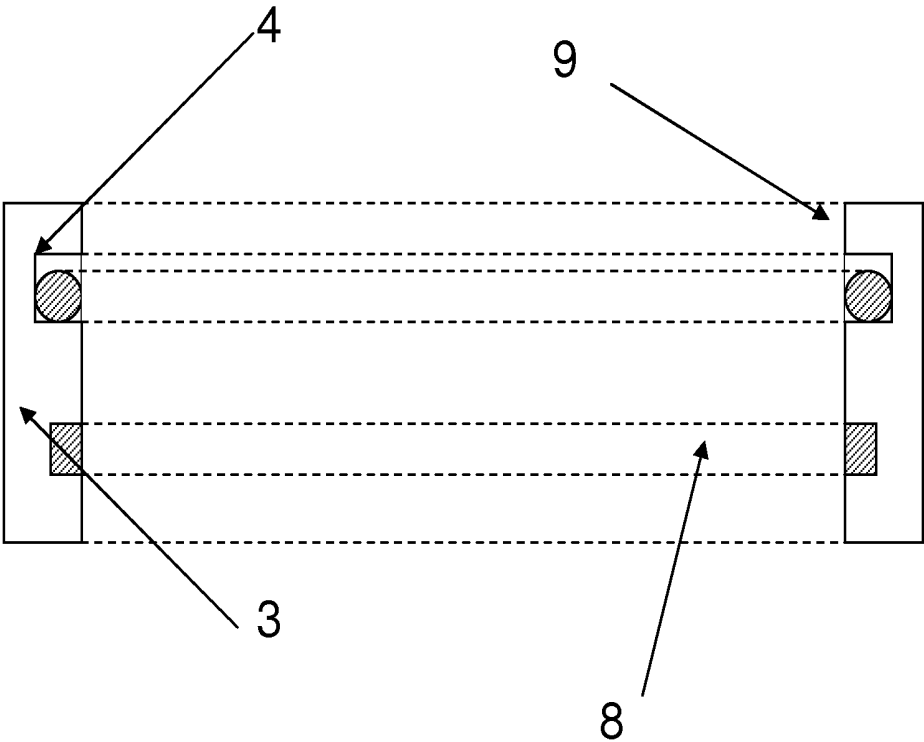

Fig. 12



**Fig. 13**



**Fig. 14**

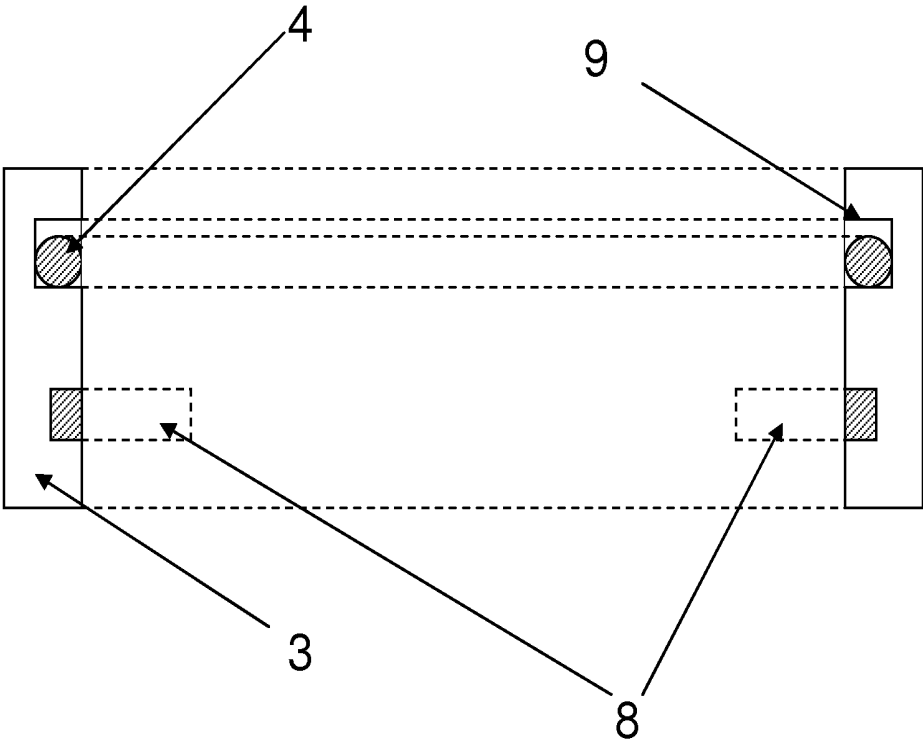

**Fig. 15**

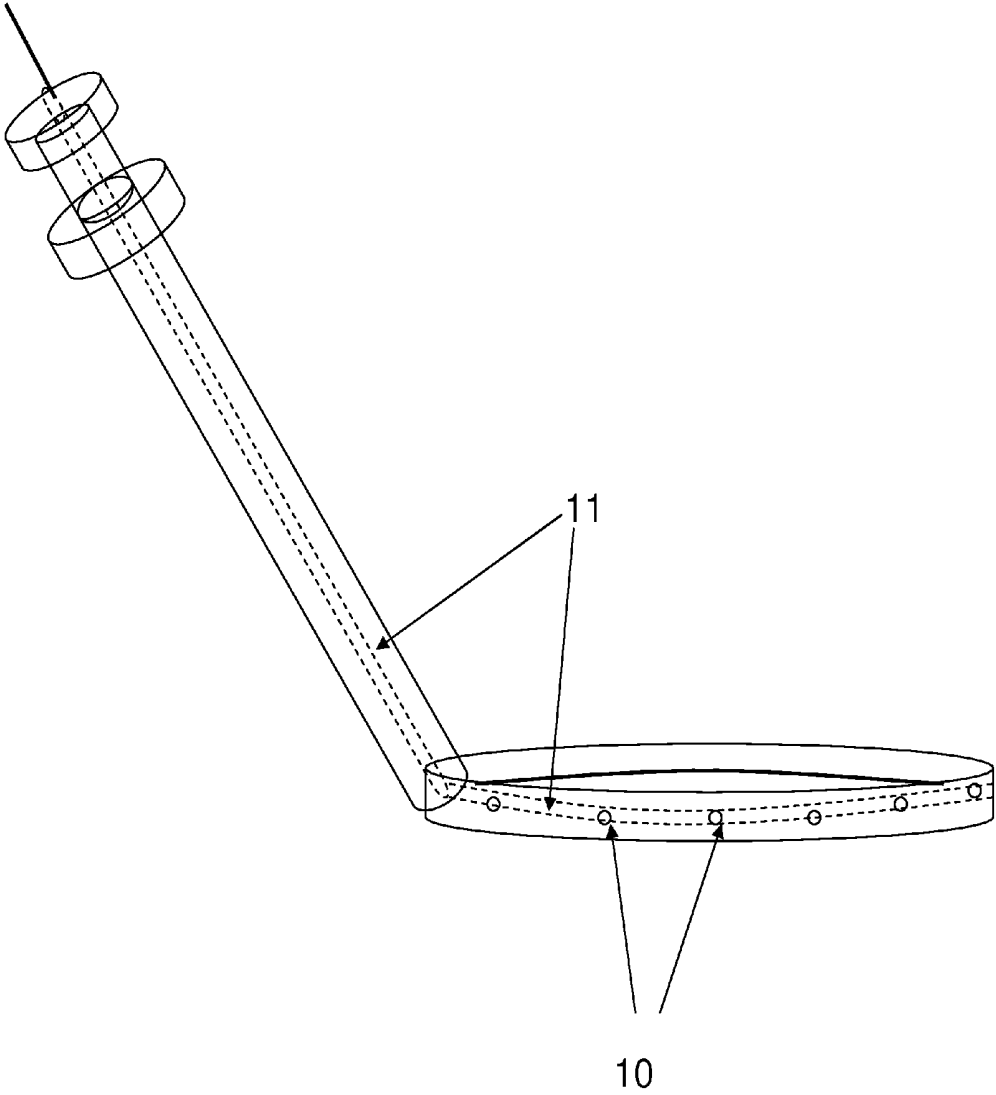

Fig. 16

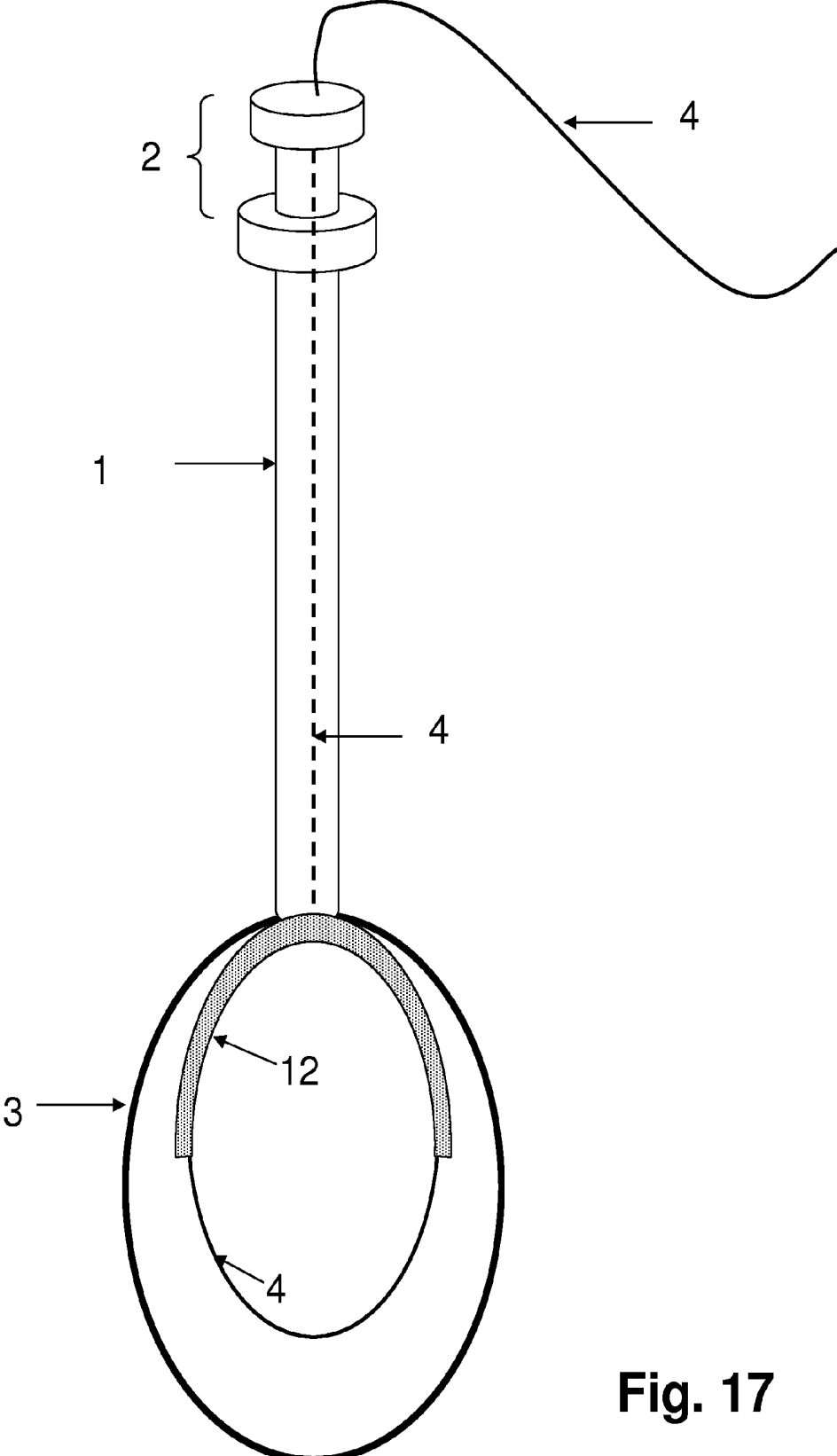

Fig. 17

## HEMOSTASIS AND TRANSECTION OF TISSUE

### CROSS-REFERENCE TO RELATED APPLICATIONS

[0001] This application is a continuation-in-part of U.S. application Ser. No. 12/897,736, now U.S. Pat. No. 9,095,369, issued Aug. 4, 2015, which is a continuation of U.S. application Ser. No. 11/770,714, filed Jun. 28, 2007, now U.S. Pat. No. 7,806,894, issued Oct. 5, 2010, which claims the benefit of U.S. provisional application Ser. No. 60/806,031, filed Jun. 28, 2006, which is hereby incorporated herein by reference. The subject matter disclosed herein was also disclosed in U.S. provisional application Ser. No. 60/694,163, filed Jun. 27, 2005, which is hereby incorporated herein by reference as evidence of constructive reduction to practice.

### FIELD

[0002] The disclosed systems and methods relate generally to systems and methods for achieving hemostasis and transection of tissues during surgery. More specifically, the disclosed systems and methods relate to surgical instruments and that deliver electrical current to tissues.

### BACKGROUND

[0003] Surgery may involve control of vascular structures that supply blood to tissues, in order to prepare the tissue for removal from the body. For example, hysterectomy, whether performed abdominally, vaginally, or laparoscopically, requires control of the blood supply to the uterus, namely the uterine and ovarian arteries, before the organ can be transected and removed. With laparoscopic supracervical hysterectomy (LSH), for example, the technique often involves ligation of the uterine-ovarian (or infundibulo-pelvic) ligaments, the broad and cardinal ligaments, the last of which contains the uterine arteries. Several techniques are used to transect these tissues and ligate the blood vessels contained within them including mono- and bi-polar electro-coagulation, staples, sutures and the harmonic scalpel. Once the uterine arteries have been ligated, the cervix may be amputated by one of several methods, including monopolar or bipolar cautery, the harmonic scalpel, or by cutting the cervix with scissors. These techniques, while effective, usually take significant time and skill, especially in avoiding injury to neighboring structures, including the bowel and ureters. Visualization of this area is essential during the amputation of the cervix, and is often hampered by an enlarged uterus, the presence of lower uterine segment or cervical fibroids, or by bowel that is difficult to retract from the cul-de-sac.

### SUMMARY

[0004] The present disclosure provides systems and methods for surgical hemostasis and transection of tissues. In one exemplary embodiment, a laparoscopic instrument includes a cylindrical shaft, which is placed into the abdomen or pelvis, through a trocar port. Once placing the instrument inside the body, the surgeon deploys it by pushing a syringe-like mechanism or other actuator outside the body. This introduces a double-ring that opens up within the peritoneal cavity. The outer ring, referred to as the stabilization ring, may be wide and thin, like a ribbon, and may be electrically insulated. Within or attached to the outer ring may be a metallic, plastic,

or otherwise stiff material that maintains the circular shape of the ring once it has been deployed inside the body. The inner ring, referred to as the transection wire, is adherent to the outer ring during deployment, but may be withdrawn into the cylindrical shaft independently of the outer ring, and an electrical current is applied to the wire.

[0005] After the uterine arteries have been ligated during the supracervical hysterectomy by one of several means, as described above, the device may be introduced through one of the laparoscopic trocar ports into the peritoneal cavity. The rings are then deployed by pressing the mechanism on the handle, which opens the ring, and these rings are placed over the uterine fundus like a lasso. The axis of the inner and outer rings may be deviated in relationship to the axis of the hollow cylinder, in order to position the rings in the proper position. This change in the axis of the rings may be performed with an articulating mechanism, or the ring may be simply bent by pushing up against tissue in the body. The device is brought down approximately to the level of the internal cervical os, and the rings are cinched down around the cervix by pulling back on the syringe-like mechanism. Once the seal is tight around the cervix, the outer ring may be locked into place, so that it does not loosen up. Any uterine manipulator, which may be metallic or plastic, should be removed from the cervix at this point. The instrument is attached to an electrical generator and a monopolar current is applied to the inner ring. At the same time, the inner transection wire is withdrawn through the tissue and into the cylindrical shaft. The outer stabilization ring holds the cervix in place and also acts to protect surrounding tissues from injury, since it may be insulated. Once the wire has been completely withdrawn into the shaft, a visual, tactile or auditory signal may be used to indicate to the surgeon that the transection is complete, and the electrical current is stopped. Alternatively, once the wire has been withdrawn back into the cylinder, the electric current may automatically shut off. This action separates the uterine fundus from the cervix. The stabilization ring may then be loosened, and withdrawn back into the cylindrical shaft of the instrument. At this point, the instrument may be removed from the body. The uterine itself would next be removed from the body, with one of several methods, including morcellation or posterior colpotomy.

[0006] In another embodiment, the inner transection wire may be insulated except for the outer half or other proportion of the distal segment of the loop.

[0007] In another embodiment, the outer stabilization ring may have a second wire embedded within it, which may be exposed on the inside of the ring. This outer ring wire may be exposed circumferentially, or it may only be exposed on either side for several centimeters, which would correspond with the location of the uterine arteries. This technique may be used when the surgeon is able to transect lateral tissues, such as the broad ligament, but does not or can not ligate the uterine vessels. The rings are deployed as stated above and cinched down around the cervix. Bipolar electrical current is then applied, which causes cauterization of the uterine arteries. The surgeon may look for several cues that the cauterization is complete, such as an auditory signal from an ammeter (indicating that the tissue has completed coagulation), or visual confirmation that the uterus has become cyanotic from cauterization of its blood supply. Once the surgeon has determined that the blood supply has been ligated, the bipolar energy is turned off and monopolar energy is applied to the inner transection wire, as described above. The outside of the

outer stabilization ring may have visual markings that indicate the location of the outer ring conductive elements.

[0008] In another embodiment, the outer insulated stabilization wire may have a channel running within and holes on the outside, inside or along the edges of the outer ring. This channel may be connected to a channel that runs throughout the length of the cylinder and is attached to a suction canister. Once cauterization begins (either for the uterine arteries or to transect the uterus), suction is activated (either manually or automatically, when electrocoagulation is engaged), which may control the amount of smoke that is generated from the device. The channel ring may also be coupled to a fluid source under positive pressure and thereby provide irrigation to the surgical site.

[0009] In another embodiment, the inner and outer wires may come out from the end of the instrument without a ring configuration. The surgeon would manually grasp the ends of the wires, which may have an attachment device located on the end of the wires, and bring the wires around the cervix. The surgeon would then attach the distal end of the wires to another position along the wire; thus, creating a loop configuration. This may be useful, for example, in cases where the uterus is too large to place the loop over the top of the uterine fundus.

#### BRIEF DESCRIPTION OF THE DRAWINGS

[0010] These and other features and advantages of the systems and methods disclosed herein will be more fully understood by reference to the following detailed description in conjunction with the attached drawings in which like reference numerals refer to like elements through the different views. The drawings illustrate principles of the systems and methods disclosed herein and are not necessarily to scale. Implied absolute or relative dimensions are not limiting but are instead provided for illustrative purposes.

[0011] FIG. 1 depicts an exemplary embodiment of a double-ring device, with a cylindrical shaft, a syringe like hand-activated handle that deploys and retracts the double ring system, and a device that retracts the transection wire.

[0012] FIG. 2 provides another view of the instrument shown in FIG. 1 and shows an exemplary ribbon-like configuration of the outer ring.

[0013] FIG. 3 depicts an embodiment in which the outer and inner rings are angled relative to the shaft.

[0014] FIG. 4 illustrates movement of the handle to reduce the sizes of the outer and inner rings, in order to adjust the size of the rings around the tissues to be excised.

[0015] FIG. 5 demonstrates the positioning of the instrument over the uterine fundus and cinched down over the cervix.

[0016] FIG. 6 illustrates the pulling of the inner transection wire through the cervix.

[0017] FIG. 7 illustrates the inner transection wire continuing to be pulled through the tissues and transecting through approximately half of the cervix.

[0018] FIG. 8 demonstrates the inner transection wire almost completely pulled through the cervical tissue.

[0019] FIG. 9 demonstrates the completed transection through the cervix, after the inner transection wire has been withdrawn through the tissues and into the cylinder. The stabilization ring is still in place over the cervix.

[0020] FIG. 10 demonstrates the cervix released from the stabilization ring and the stabilization ring being withdrawn back into the cylinder.

[0021] FIG. 11 demonstrates a second wire on the inner aspect of the outer ring that is exposed in only two separate areas, opposite from one another, in an area that would correspond to the location of the vascular supply to the uterus.

[0022] FIG. 12 illustrates the inner wire being withdrawn through the tissues and into the cylinder.

[0023] FIG. 13 illustrates a cross-section of an exemplary arrangement of the outer and inner rings.

[0024] FIG. 14 shows a cross-section of another embodiment of the instrument, with a second wire that is within the outer ring, and is exposed circumferentially around the inner aspect of the outer ring.

[0025] FIG. 15 shows a cross-section of another embodiment of the instrument, with a second wire that is within the outer ring, but is electrically exposed only on two opposite sides of the ring.

[0026] FIG. 16 illustrates the presence of smoke aspiration holes located around the circumference of the instrument, attached to a channel that travels up the shaft of the cylindrical instrument.

[0027] FIG. 17 illustrates another embodiment of the inner transection wire, which may be partially insulated proximally.

#### DETAILED DESCRIPTION

[0028] For clarity and convenience, a number of exemplary embodiments will be described relating to a particular anatomic site, the female pelvis. However, it will be readily apparent to one of ordinary skill in the art that the disclosed systems and methods may be employed in a wide variety of anatomical settings to treat a broad range of abnormalities.

[0029] FIG. 1 illustrates the general design of the instrument. It may include a cylindrical hollow tube (1), a handle (2) and two rings that are deployed out from the end of the cylindrical tube: an outer insulated stabilization ring (3) which is thin but wide (as a ribbon), and an inner transection wire (4), which connects to a wire that runs up the cylinder, out through the handle and connects to an electrical generator. Pushing in on the handle deploys the two rings together out from the end of the cylinder and pulling back on the handle draws the rings back into the cylinder. Alternatively, such an instrument may employ other mechanisms for separately or collectively deploying and retracting the two rings.

[0030] FIG. 2 depicts the device in the open position with outer ring (3) and inner wire (4). The deployment of the two rings would typically be performed once the instrument is placed in the body in order to place the rings over the tissue to be excised.

[0031] FIG. 3 illustrates the ability of the outer and inner rings to bend after insertion in the abdomen. This might be required in order to position the rings over the uterine fundus and down to the level of the internal cervical os, which would be a typical placement for performing a supracervical hysterectomy.

[0032] FIG. 4 demonstrates how the handle is pulled back in order to reduce the size of the outer and inner rings. The inner wire is attached to the handle so that both rings can be deployed and withdrawn together; however, the inner wire can be detached from the handle so that the inner wire can be drawn back independently of the outer wire for transection of tissues while maintaining the position of the outer stabilization ring on the cervix.

[0033] FIG. 5 demonstrates the placement of the double rings at the level of the internal cervical os after the rings have been placed over the uterus (5).

[0034] FIG. 6 illustrates the inner wire (4), having been separated from the handle, being pulled and withdrawn through the cervix while an electrical current is applied to the wire.

[0035] FIG. 7 illustrates the inner wire (4) continuing to be pulled through the tissues with an electrical current applied. Before this step begins, the surgeon removes any uterine manipulator that has been placed into the cervix.

[0036] FIG. 8 illustrates the inner wire (4) has now been completely pulled through the tissue and has transected the uterine fundus.

[0037] FIG. 9 demonstrates the uterus (5) having been completely transected and the endocervical canal is now visible (6). The stabilization ring (3) is still around the cervix.

[0038] FIG. 10 demonstrates the endocervical canal (6) that can be visualized on the cervix (7) and on the uterine specimen. The outer stabilization ring (3) is being withdrawn back into the cylinder.

[0039] FIG. 11 demonstrates another embodiment of the instrument, where an exposed wire or other conductive material (8) is present on opposite sides of the outer ring, and is used to create a bipolar current with the inner wire (4) to coagulate vessels, such as the uterine vessels during the supracervical hysterectomy. In other embodiments, the wire (8) may be exposed at other or additional positions around the ring or may be exposed around the entire ring.

[0040] FIG. 12 demonstrates the inner wire (4) being pulled through tissue with monopolar cautery after bipolar cauterization of the vessels with both the inner wire (4) and the outer ring conductive elements (8).

[0041] FIG. 13 is a cross-section of one embodiment of the device with the inner ring (4) located within a groove (9) of the outer insulated ring (3).

[0042] FIG. 14 is a cross-section of another embodiment of the device with the inner ring (4), and the outer ring containing a conductive element (8) that is located circumferentially within or attached to the outer ring.

[0043] FIG. 15 is a cross-section of another embodiment of the device with the outer ring conductive elements (8) located at opposite ends of the outer ring.

[0044] FIG. 16 demonstrates another embodiment of the outer ring, with a series of holes located on the outer ring (10) that are connected to a channel (11) that comes out from the handle of the instrument and is connected to suction (in order to evacuate smoke from the area during electrocoagulation of

tissue, either with monopolar or bipolar energy) or to a fluid source for infusion of gas or liquid into the surgical site.

[0045] FIG. 17 illustrates another embodiment of the inner transection wire, whereby some part of the proximal wire is insulated (12).

[0046] Although the description and figures provided herein concern supracervical hysterectomy, the device itself can be used and/or is adaptable to be used with a wide variety of other anatomic portions, such as the gallbladder, liver, lung, pancreas, spleen, kidney, muscle, and bone. The device may also be used to remove pathological structures, such as polyps and neoplasms. Devices customized for particular anatomic regions or uses can be provided with predetermined sizes for the ring (3), wire (4), and/or element(s) (8), and optionally with predetermined number and position of element(s) (8).

We claim:

1. An electrical instrument comprising an insulation ring, a first electrocautery conductor, and a shaft, wherein:
  - the insulation ring and the first electrocautery conductor each form a loop attached to a distal end of the shaft;
  - the insulation ring and the first electrocautery conductor are each operatively coupled to the shaft so as to be separately expandable and retractable relative to the distal end of the shaft;
  - the insulation ring is formed at least in part by an electrical insulator; and
  - the first electrocautery conductor is formed at least in part by an electrical conductor.
2. The instrument of claim 1, further comprising an electrical power source to which connector ends of the first electrocautery conductor are so coupled as to apply monopolar current to the first electrocautery conductor.
3. The instrument of claim 1, further comprising a second electrocautery conductor affixed to an inward-facing side of the insulation ring.
4. The instrument of claim 3, further comprising an electrical power source to which connector ends of the second electrocautery conductor and the first electrocautery conductor are so coupled as to apply bipolar current between the first and second electrocautery conductors.
5. The instrument of claim 4, wherein the second electrocautery conductor comprises a pair of electrodes positioned at opposing locations of the insulation ring.
6. The instrument of claim 4, wherein the second electrocautery conductor comprises a conductor loop extending along at least half of the inward-facing side of the insulation ring.

\* \* \* \* \*

专利名称(译)	止血和横断组织		
公开(公告)号	<a href="#">US20160184009A1</a>	公开(公告)日	2016-06-30
申请号	US14/816436	申请日	2015-08-03
[标]申请(专利权)人(译)	新英格兰ASSOC妇科LAPAROSCOPISTS		
申请(专利权)人(译)	新英格兰协会妇科LAPAROSCOPISTS, LLP		
当前申请(专利权)人(译)	新英格兰协会妇科LAPAROSCOPISTS, LLP		
[标]发明人	ROSENBLATT PETER L DISCIULLO ANTHONY J		
发明人	ROSENBLATT, PETER L. DISCIULLO, ANTHONY J.		
IPC分类号	A61B18/14		
CPC分类号	A61B18/1492 A61B2018/00559 A61B2018/00595 A61B2018/00607 A61B2018/00083 A61B2018/1253 A61B2018/126 A61B2018/141 A61B2018/00077 A61B2018/00642 A61B17/32056 A61B18/14 A61B18 /1482 A61B2017/4216 A61B2018/1407 A61B2018/144		
优先权	60/694163 2005-06-27 US 60/806031 2006-06-28 US		
外部链接	<a href="#">Espacenet</a> <a href="#">USPTO</a>		

摘要(译)

腹腔镜烧灼器械可包括细长轴，连接到轴并可相对于轴移动的手柄，绝缘环和单极烧灼线。腹腔镜烧灼器械可包括细长轴，连接到轴并可相对于轴移动的手柄，单极烧灼线和电导体。

