



US 20150327886A1

(19) **United States**

(12) **Patent Application Publication**
SHEN et al.

(10) **Pub. No.: US 2015/0327886 A1**
(43) **Pub. Date: Nov. 19, 2015**

(54) **METHOD FOR MANUFACTURING DISPOSABLE ENDOSCOPIC PUNCTURE OUTFIT FOR LAPAROSCOPY OPERATIONS AND A PUNCTURE OUTFIT USING THE METHOD**

Publication Classification

(51) **Int. Cl.**
A61B 17/34 (2006.01)
A61B 1/05 (2006.01)
A61B 1/018 (2006.01)
(52) **U.S. Cl.**
CPC *A61B 17/3478* (2013.01); *A61B 1/018* (2013.01); *A61B 1/05* (2013.01); *A61B 17/3496* (2013.01)

(71) Applicants: **Zhenquan SHEN**, GUANGDONG (CN); **Chengjun GOU**, GUANGDONG (CN); **Zhitan YAN**, GUANGDONG (CN); **Zhenning HUANG**, GUANGDONG (CN)

(72) Inventors: **Zhenquan SHEN**, GUANGDONG (CN); **Chengjun GOU**, GUANGDONG (CN); **Zhitan YAN**, GUANGDONG (CN); **Zhenning HUANG**, GUANGDONG (CN)

(21) Appl. No.: **14/738,945**

(22) Filed: **Jun. 15, 2015**

Related U.S. Application Data

(62) Division of application No. 14/002,739, filed on Sep. 3, 2013, filed as application No. PCT/CN2012/080092 on Aug. 14, 2012.

Foreign Application Priority Data

Nov. 1, 2011 (CN) 201110338794.9

(57) **ABSTRACT**

A method for manufacturing a disposable endoscopic puncture outfit for laparoscopy operations and a puncture outfit made according to the method are provided. The puncture outfit has a camera shooting module with a light source, a puncture needle and a positioning puncture casing pipe that matches with the puncture needle; the camera shooting module is set at a head end of the puncture needle; the head end of the puncture needle is sheathed with a transparent cover that can cover the camera shooting module; the puncture needle is inserted in the positioning puncture casing pipe to make the transparent cover at the head end of the puncture needle slightly extend out of the positioning puncture casing pipe. The puncture outfit can be used for visible surgical procedures through the camera shooting module.

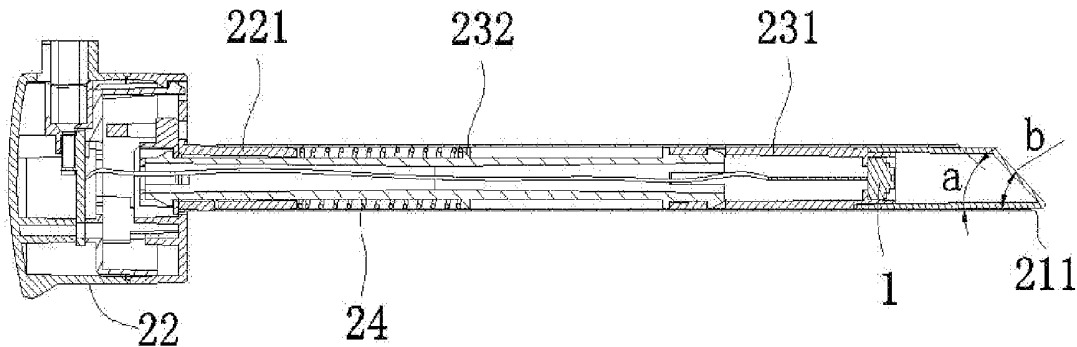

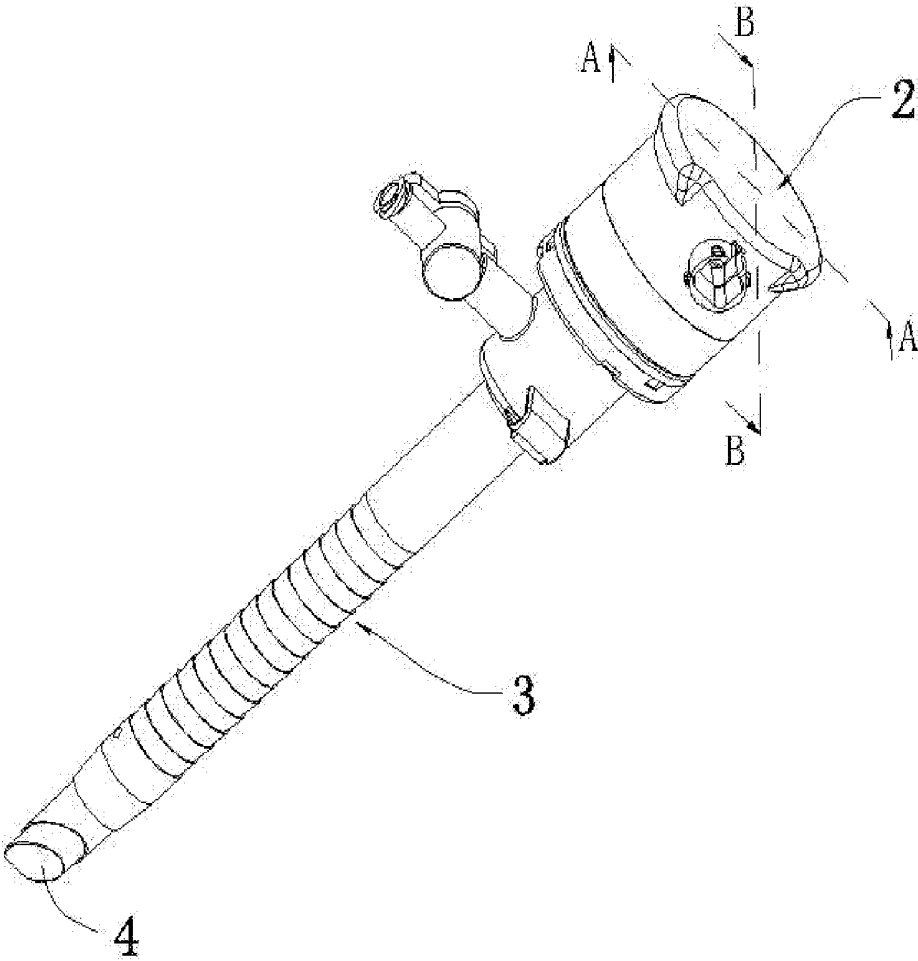

FIG.1

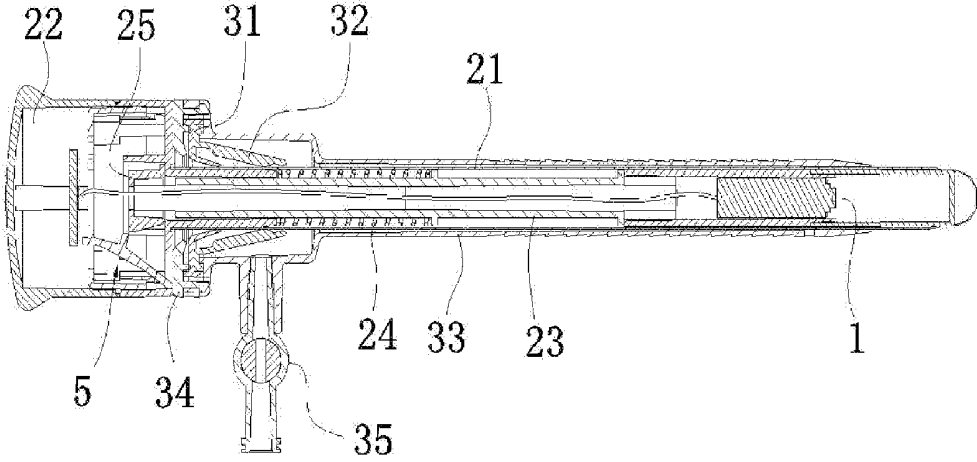

FIG.2

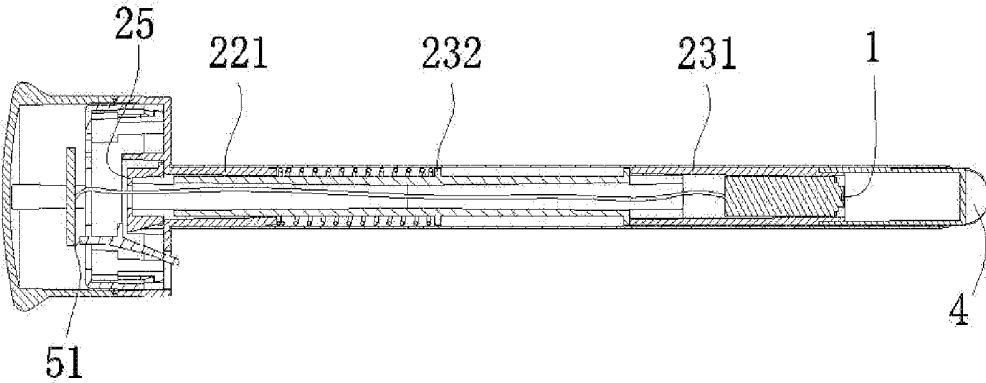

FIG.3

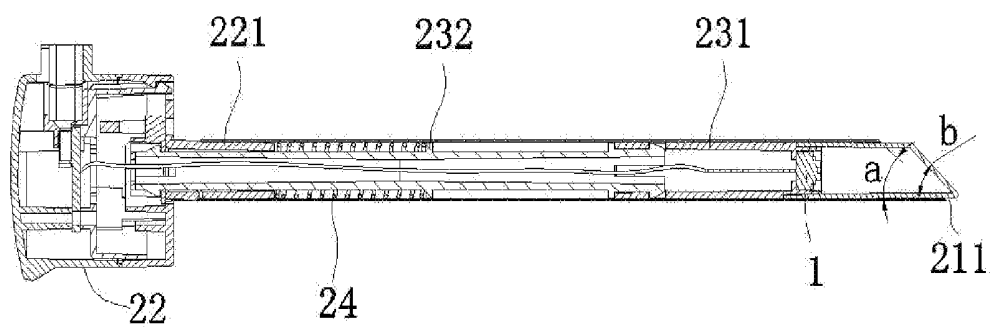

FIG. 4

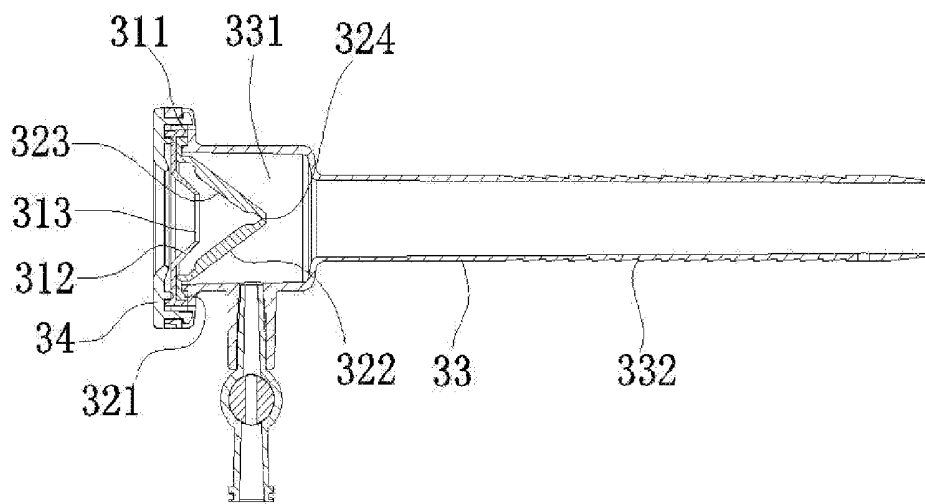

FIG. 5

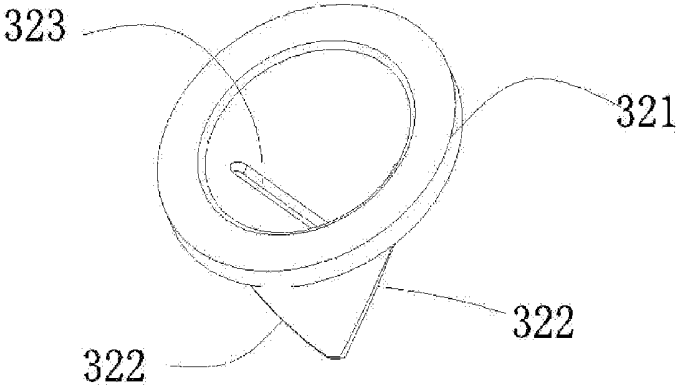

FIG.6

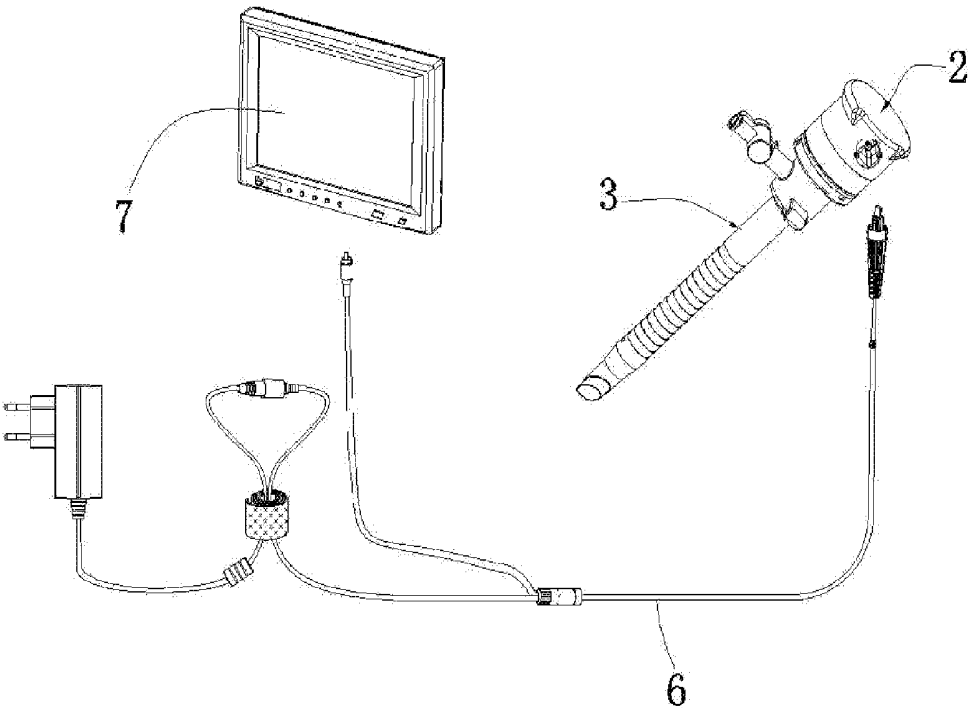

FIG.7

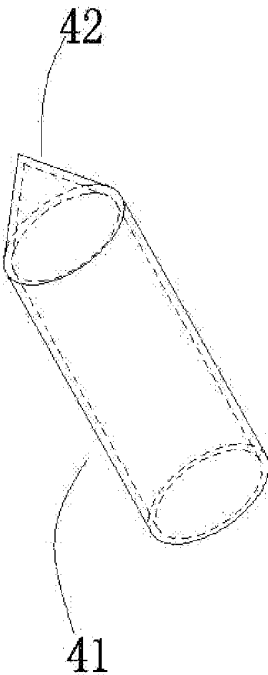

FIG. 8

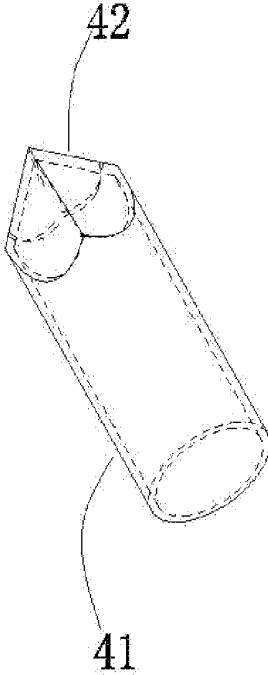

FIG. 9

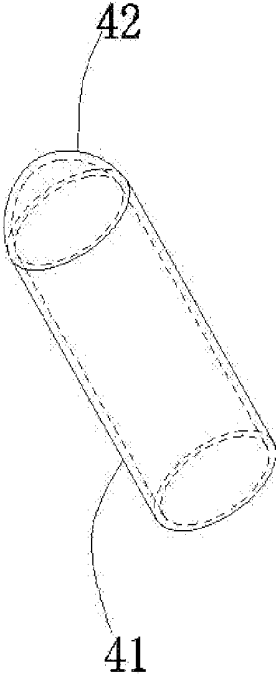

FIG.10

**METHOD FOR MANUFACTURING
DISPOSABLE ENDOSCOPIC PUNCTURE
OUTFIT FOR LAPAROSCOPY OPERATIONS
AND A PUNCTURE OUTFIT USING THE
METHOD**

CROSS REFERENCE OF RELATED
APPLICATIONS

[0001] This application is a divisional application of Ser. No. 14/002,739 which is a U.S. national entry of PCT application PCT/CN2012/080092.

BACKGROUND OF THE INVENTION

[0002] This invention pertains to the technical field of medical apparatus and particularly to a method for manufacturing a disposable endoscopic puncture outfit for laparoscopy operations and a puncture outfit using the method.

[0003] The minimally invasive surgery represented by laparoscope has developed rapidly in recent years. The surgery quantity has been more than that of traditional surgery in developed countries. The minimally invasive treatment technologies characterized by minor surgery and minor wound have gradually been recognized by extensive surgeons. Casing pipe puncture outfit is a necessary apparatus to set up surgical and observation channels in laparoscopic surgery. However, the existing casing pipe has no visible function. That is, "blind placement" is adopted. The surgeons carry out the surgery all by their experience. During the puncture process, the artery blood vessels such as retroperitoneal aorta and artery blood vessels of abdominal wall cannot be seen or touched in blind placement. Therefore, it is operated inconveniently. In case of injuries, it usually results in fatal hemorrhage and surgery incidents. Moreover, the normal tissues of visceral organs are easily injured accidentally such as vascular, intestine and bladder injuries when the casing pipe puncture outfit is inserted in the abdominal cavity. There is a hidden danger for laparoscopic surgery complications, which can hardly guarantee the surgery safety and effectiveness.

BRIEF SUMMARY OF THE INVENTION

[0004] In allusion to the above shortcomings, one of the purposes for this invention is to provide a method for manufacturing a disposable endoscopic puncture outfit for laparoscopy operations that features simple process, easy implementation, high efficiency and effectiveness.

[0005] The other purpose for this invention is to provide a puncture outfit that features is designed with reasonable structure, can be visible throughout the surgery and is operated conveniently.

[0006] To realize the above purposes, the technical solutions provided by this invention include:

[0007] A method for manufacturing a disposable endoscopic puncture outfit for laparoscopy operations, characterized in that it comprises the following steps:

[0008] (1) Prepare a camera shooting module with light source;

[0009] (2) Prepare a puncture needle;

[0010] (3) Prepare a positioning puncture casing pipe that matches with the said puncture needle;

[0011] (4) Mount the camera shooting module at the head end of the puncture needle. The head end of the said puncture needle is sheathed with a transparent cover that can cover camera shooting module;

[0012] (5) Insert the puncture needle in the positioning puncture casing pipe, and make a transparent cover at the head end of the said puncture needle slightly extend out of the said positioning puncture casing pipe to manufacture a disposable endoscopic puncture outfit for laparoscopy operations.

[0013] The said step (2) further comprises the following steps:

[0014] (2.1) Prepare a needle guard;

[0015] (2.2) Prepare a handle;

[0016] (2.3) Prepare a protective rod;

[0017] (2.4) Prepare a reset spring;

[0018] (2.5) A sleeve joint part that matches with the needle guard is set on the front side wall of the handle. The tail end of the needle guard is sheathed on the sleeve joint part of the handle to make the head end of the said needle guard form a single bevel blade. The tilting angle of the bevel of the said blade is between 20~70 degrees.

[0019] (2.6) A mounting rack that matches with the camera shooting module is mounted at the head end of the protective rod. Mounting positions that match with the transparent cover are reserved at the head end of the said mounting rack.

[0020] (2.7) A boss is set in the middle of the protective rod. The reset spring is sheathed at the tail end of the protective rod, the tail end of the said protective rod is inserted in the needle guard to pass through the sleeve joint part and stretch into the handle. One end of reset spring on the said protective rod presses against the sleeve joint part while the other end presses against the boss. Moreover, a clamping cap is set at the tail end of the protective rod to prevent it from moving out of the handle. A puncture needle is thus manufactured.

[0021] The said step (2) further comprises the following steps:

[0022] (2.8) Prepare a protection mechanism;

[0023] (2.9) The said protection mechanism is set in the handle of the puncture needle and can prevent the transparent cover from withdrawing back into the needle guard when the puncture needle is not used. If the puncture needle is used with the positioning puncture casing pipe, a protection function will be automatically started to prevent the needle guard that stretches into the abdominal cavity from accidentally injuring the visceral organs.

[0024] The said step (3) further comprises the following steps:

[0025] (3.1) Prepare a sealing gasket: a buckle is set on the outer edge of the said sealing gasket. The middle part of the sealing gasket has a conical bulge in a side. A through-hole that matches with the said needle guard is set at the central position of the said bulge. The said through-hole has an interference fit with the said needle guard.

[0026] (3.2) Prepare a check valve made with flexible material. A hook is set on the outer edge of the said check valve. Two anti-pressing plates are set in the middle part of the check valve. The two anti-pressing plates are set oppositely in a closing shape to form an elongated gap that matches with the said needle guard between their two adjacent end faces. A convex rib is set respectively on the inner sides of the two anti-pressing plates to strength their structural strength. When the said needle guard is moved out of the elongated gap, the said convex rib can have the two adjacent end faces of the two anti-pressing plates closely pressed against each other to prevent the high-pressure gas in the abdominal cavity from leaking.

[0027] (3.3) Prepare a casing pipe sheath made with high polymer material. A cavity that matches with the contour of the said check valve is formed at the tail end of the said casing pipe sheath. The head end of the said casing pipe sheath extends at its axial direction, and its outer side is set with a nodular and conical bulge. The head end of the said casing pipe sheath is in a conical shape.

[0028] (3.4) Place the said check valve in the cavity of the said casing pipe sheath, and have the hook of the said check valve buckled on the opening of the said cavity.

[0029] (3.5) Have the sealing gasket set on the opening of the cavity, and have the buckle of the said sealing gasket buckled on the hook of the check valve.

[0030] (3.6) Prepare an upper cover, have the said upper cover fastened on the opening of the said cavity, and have the said sealing gasket and the check valve positioned in the cavity of the casing pipe sheath.

[0031] (3.7) Prepare a two-way valve, have the said two-way valve fixed on the said casing pipe sheath, and have the said two-way valve and the cavity of the said casing pipe sheath connected to manufacture a positioning puncture casing pipe.

[0032] The said transparent cover is a round pipe body whose one end is closed. The closing part of the said round pipe body is in a beveled, spherical, conical or polygonal pyramid shape. When the closing part of the said round pipe body is in a beveled shape, the tilting angle of its bevel is 20~70 degrees.

[0033] A puncture outfit made with a method for manufacturing a disposable endoscopic puncture outfit for laparoscopy operations comprises a camera shooting module with light source, a puncture needle and a positioning puncture casing pipe that matches with the said puncture needle. The said camera shooting module is set at the head end of the puncture needle. The head end of the said puncture needle is sheathed with a transparent cover that can cover camera shooting module. The said puncture needle is inserted in the positioning puncture casing pipe to make the transparent cover at the head end of the said puncture needle slightly extend out of the said positioning puncture casing pipe.

[0034] The said puncture needle comprises a needle guard, a handle, a protective rod and a reset spring. A sleeve joint part that matches with the needle guard is set on the front side wall of the handle. The tail end of the needle guard is sheathed on the sleeve joint part of the handle to make the head end of the said needle guard form a single bevel blade. The tilting angle of the bevel of the said blade is between 20~70 degrees. A mounting rack that matches with the camera shooting module is mounted at the head end of the protective rod. Mounting positions that match with the transparent cover are reserved at the head end of the said mounting rack. A boss is set in the middle of the protective rod. The tail end of the said protective rod is inserted in the needle guard to pass through the sleeve joint part and stretch into the handle. Moreover, a clamping cap is set at the tail end of the protective rod to prevent it from moving out of the handle. The reset spring is sheathed at the tail end of the protective rod, and one end of the said reset spring presses against the sleeve joint part while the other end presses against the boss.

[0035] The said puncture needle further comprises a protection mechanism. The said protection mechanism comprises an elastic arm whose head end is fixed in the handle. The middle part of the elastic arm is set with a clamping position that can block the clamping cap to prevent the trans-

parent cover from withdrawing back into the needle guard when the puncture needle is not used. The tail end of the elastic arm extends out from the front side wall of the handle to form a dial piece that presses against the said positioning puncture casing pipe to make the clamping position move out of from the clamping cap when the puncture needle is matched with the positioning puncture casing pipe.

[0036] The said positioning puncture casing pipe comprises a casing pipe sheath, an upper cover, a sealing gasket, a check valve and a two-way valve. A buckle is set on the outer edge of the said sealing gasket. The middle part of the sealing gasket has a conical bulge in a side. A through-hole that matches with the said needle guard is set at the central position of the said bulge. The said through-hole has an interference fit with the said needle guard. A hook is set on the outer edge of the said check valve. Two anti-pressing plates are set in the middle part of the check valve. The two anti-pressing plates are set oppositely in a closing shape to form an elongated gap that matches with the said needle guard between their two adjacent end faces. A convex rib is set respectively on the inner sides of the two anti-pressing plates to strength their structural strength. A cavity that matches with the contour of the said check valve is formed at the tail end of the said casing pipe sheath. The head end of the said casing pipe sheath extends at its axial direction, and its outer side is set with a nodular and conical bulge. The head end of the said casing pipe sheath is in a conical shape. The said check valve is set in the cavity of the casing pipe sheath, and the hook of the said check valve is buckled on the opening of the said cavity. The said sealing gasket is set on the opening of the cavity, and the buckle of the said sealing gasket is buckled on the hook of the check valve. The said upper cover is fastened on the opening of the said cavity, and the said sealing gasket and the check valve are positioned in the cavity of the casing pipe sheath. The said two-way valve is fixed on the said casing pipe sheath, and the said two-way valve and the cavity of the said casing pipe sheath are connected each other.

[0037] The said transparent cover is a round pipe body whose one end is closed. The closing part of the said round pipe body is in a beveled, spherical, conical or polygonal pyramid shape. When the closing part of the said round pipe body is in a beveled shape, the tilting angle of its bevel is 20~70 degrees.

[0038] Beneficial effects of this invention: The manufacturing method provided by this invention has a simple process, is easy to implement, and has high production efficiency. The puncture outfit provided by this invention is designed smartly, has a reasonable structure and can be used for visible surgical procedures through the camera shooting module, and can prevent the normal tissues or viscera from being accidentally injured in blind sight, effectively improve the safety of the puncture surgery and reduce the medical negligence. Moreover, the operation can be carried out in a visible state, which can greatly shorten the duration of surgery and reduce the pain of patients. It features simple operation and low cost, and lies less on the skill of a surgeon, and the accuracy and success rate of the surgery can be increased.

[0039] A nodular and conical bulge is set on the casing pipe sheath. It has good fixity and does not slip, which can avoid the common safety incident due to easy slipping. Moreover, the head end of the casing pipe sheath is in a conical shape, which can reduce the resistance during puncturing and further relieve the incision injury. It is operated conveniently and can realize the minimally invasive effect. Moreover, it features

simple entire structure, easy implementation, low cost and disposable use. It can avoid cross infection and ensure the safe use.

[0040] The head end of the said needle guard forms a single bevel blade. The tilting angle of the bevel of the said blade is between 20~70 degrees. Its blade can be effectively used to incise the tissues. Hole is expanded along the tilting angle. It brings minor injury and effectively improves the safety and effectiveness of the puncture surgery.

[0041] Further explanation for this invention is given through the following figures and embodiments.

BRIEF DESCRIPTION OF THE DRAWINGS

[0042] FIG. 1 is a solid structure diagram of this invention;

[0043] FIG. 2 is an A-A section structure diagram in FIG. 1;

[0044] FIG. 3 is an A-A section structure diagram of puncture needle in FIG. 1;

[0045] FIG. 4 is a B-B section structure diagram of puncture needle in FIG. 1;

[0046] FIG. 5 is an A-A section structure diagram of positioning puncture casing pipe in FIG. 1;

[0047] FIG. 6 is a structure diagram of check valve in FIG. 1;

[0048] FIG. 7 is a state structure diagram during the use of this invention;

[0049] FIG. 8 is a structure diagram 1 of transparent cover in FIG. 1;

[0050] FIG. 9 is a structure diagram 2 of transparent cover in FIG. 1;

[0051] FIG. 10 is a structure diagram 3 of transparent cover in FIG. 1;

DETAILED DESCRIPTION OF THE INVENTION

Embodiment

[0052] Refer to FIG. 1-6. This invention embodiment provides a method for manufacturing a disposable endoscopic puncture outfit for laparoscopy operations, characterized in that it comprises the following steps:

[0053] (1) Prepare a camera shooting module with light source 1;

[0054] (2) Prepare a puncture needle 2;

[0055] (3) Prepare a positioning puncture casing pipe 3 that matches with the said puncture needle 2;

[0056] (4) Mount the camera shooting module 1 at the head end of the puncture needle 2. The head end of the said puncture needle 2 is sheathed with a transparent cover 4 that can cover camera shooting module 1;

[0057] (5) Insert the puncture needle 2 in the positioning puncture casing pipe 3, and make a transparent cover 4 at the head end of the said puncture needle 2 slightly extend out of the said positioning puncture casing pipe 3 to manufacture a disposable endoscopic puncture outfit for laparoscopy operations.

[0058] The said step (2) further comprises the following steps:

[0059] (2.1) Prepare a needle guard 22;

[0060] (2.2) Prepare a handle 22;

[0061] (2.3) Prepare a protective rod 23;

[0062] (2.4) Prepare a reset spring 24;

[0063] (2.5) A sleeve joint part 221 that matches with the needle guard 21 is set on the front side wall of the handle 22. The tail end of the needle 21 guard is sheathed on the sleeve

joint part 221 of the handle to make the head end of the said needle guard 21 form a single bevel blade 211. The tilting angle α of the bevel of the said blade 211 is between 20~70 degrees.

[0064] (2.6) A mounting rack 231 that matches with the camera shooting module 1 is mounted at the head end of the protective rod 23. Mounting positions that match with the transparent cover 4 are reserved at the head end of the said mounting rack 231.

[0065] (2.7) A boss 232 is set in the middle of the protective rod 23. The reset spring 24 is sheathed at the tail end of the protective rod 23, the tail end of the said protective rod 23 is inserted in the needle guard 21 to pass through the sleeve joint part 221 and stretch into the handle 22. One end of reset spring 24 on the said protective rod 23 presses against the sleeve joint part 221 while the other end presses against the boss 232. Moreover, a clamping cap 25 is set at the tail end of the protective rod 23 to prevent it from moving out of the handle 22. A puncture needle 2 is thus manufactured.

[0066] (2.8) Prepare a protection mechanism 5;

[0067] (2.9) The said protection mechanism 5 is set in the handle 22 of the puncture needle 2 and can prevent the transparent cover 4 from withdrawing back into the needle guard 21 when the puncture needle 2 is not used. If the puncture needle 2 is used with the positioning puncture casing pipe 3, a protection function will be automatically started to prevent the needle guard 21 that stretches into the abdominal cavity from accidentally injuring the visceral organs.

[0068] The said step (3) further comprises the following steps:

[0069] (3.1) Prepare a sealing gasket 31: a buckle 311 is set on the outer edge of the said sealing gasket 31. The middle part of the sealing gasket has a conical bulge 312 in a side. A through-hole 313 that matches with the said needle guard 21 is set at the central position of the said bulge 312. The said through-hole 313 has an interference fit with the said needle guard 21.

[0070] (3.2) Prepare a check valve 32 made with flexible material. A hook 321 is set on the outer edge of the said check valve 32. Two anti-pressing plates 322 are set in the middle part of the check valve. The two anti-pressing plates 322 are set oppositely in a closing shape to form an elongated gap 324 that matches with the said needle guard 21 between their two adjacent end faces. A convex rib 323 is set respectively on the inner sides of the two anti-pressing plates 322 to strengthen their structural strength. When the said needle guard 21 is moved out of the elongated gap 324, the said convex rib 323 can have the two adjacent end faces of the two anti-pressing plates 322 closely pressed against each other to prevent the high-pressure gas in the abdominal cavity from leaking.

[0071] (3.3) Prepare a casing pipe sheath 33 made with high polymer material. A cavity 331 that matches with the contour of the said check valve 32 is formed at the tail end of the said casing pipe sheath 33. The head end of the said casing pipe sheath 33 extends at its axial direction, and its outer side is set with a nodular and conical bulge 332. The head end of the said casing pipe sheath 33 is in a conical shape.

[0072] (3.4) Place the said check valve 32 in the cavity 331 of the said casing pipe sheath 33, and have the hook 321 of the said check valve 32 buckled on the opening of the said cavity 331.

[0073] (3.5) Have the sealing gasket 31 set on the opening of the cavity 331, and have the buckle 311 of the said sealing gasket 31 buckled on the hook 321 of the check valve 32.

[0074] (3.6) Prepare an upper cover 34, have the said upper cover 34 fastened on the opening of the said cavity 331, and have the said sealing gasket 31 and the check valve 32 positioned in the cavity 331 of the casing pipe sheath 33.

[0075] (3.7) Prepare a two-way valve 35, have the said two-way valve 35 fixed on the said casing pipe sheath 33, and have the said two-way valve 35 and the cavity 331 of the said casing pipe sheath 33 connected to manufacture a positioning puncture casing pipe 3.

[0076] The said transparent cover 4 is a round pipe body 41 whose one end is closed. The closing part 42 of the said round pipe body 41 is in a beveled, spherical, conical or polygonal pyramid shape. When the closing part 42 of the said round pipe body 41 is in a beveled shape, the tilting angle b of its bevel is 20~70 degrees.

[0077] A puncture outfit made with a method for manufacturing a disposable endoscopic puncture outfit for laparoscopy operations comprises a camera shooting module with light source 1, a puncture needle 2 and a positioning puncture casing pipe 3 that matches with the said puncture needle 2. The said camera shooting module 1 is set at the head end of the puncture needle 2. The head end of the said puncture needle 2 is sheathed with a transparent cover 4 that can cover camera shooting module 1. The said puncture needle 2 is inserted in the positioning puncture casing pipe 3 to make the transparent cover 4 at the head end of the said puncture needle 2 slightly extend out of the said positioning puncture casing pipe 3. The said transparent cover 4 is a round pipe body 41 whose one end is closed. The closing part 42 of the said round pipe body 41 is in a beveled, spherical, conical or polygonal pyramid shape. When the closing part 42 of the said round pipe body 41 is in a beveled shape, the tilting angle b of its bevel is 20~70 degrees.

[0078] The said puncture needle 2 comprises a needle guard 21, a handle 22, a protective rod 23 and a reset spring 24. A sleeve joint part 221 that matches with the needle guard 21 is set on the front side wall of the handle 22. The tail end of the needle guard 21 is sheathed on the sleeve joint part 221 of the handle 22 to make the head end of the said needle guard 21 form a single bevel blade 211 that matches with the camera shooting module 1 is mounted at the head end of the protective rod 23. Mounting positions that match with the transparent cover 4 are reserved at the head end of the said mounting rack 231. A boss 232 is set in the middle of the protective rod 23. The tail end of the said protective rod 23 is inserted in the needle guard 21 to pass through the sleeve joint part 221 and stretch into the handle 22. Moreover, a clamping cap 25 is set at the tail end of the protective rod 23 to prevent it from moving out of the handle 22. The reset spring 24 is sheathed at the tail end of the protective rod 23, and one end of the said reset spring 24 presses against the sleeve joint part 221 while the other end presses against the boss 232. The head end of the said needle guard 21 forms a single bevel blade 211. The tilting angle of the bevel of the said blade 211 is between 20~70 degrees. Its blade 211 can be effectively used to incise the tissues. Hole is expanded along the tilting angle. It brings minor injury and effectively improves the safety and effectiveness of the puncture surgery.

[0079] The said puncture needle 2 further comprises a protection mechanism 5. The said protection mechanism 5 comprises an elastic arm 51 whose head end is fixed in the handle 22. The middle part of the elastic arm is set with a clamping position that can block the clamping cap 25 to prevent the transparent cover 4 from withdrawing back into the needle

guard 21 when the puncture needle 2 is not used. The tail end of the elastic arm extends out from the front side wall of the handle 22 to form a dial piece that presses against the said positioning puncture casing pipe 3 to make the clamping position move out of from the clamping cap 25 when the puncture needle 2 is matched with the positioning puncture casing pipe 3.

[0080] The said positioning puncture casing pipe 3 comprises a casing pipe sheath 33, an upper cover 34, a sealing gasket 31, a check valve 32 and a two-way valve 35. A buckle 311 is set on the outer edge of the said sealing gasket 31. The middle part of the sealing gasket has a conical bulge 312 in a side. A through-hole 313 that matches with the said needle guard 21 is set at the central position of the said bulge 312. The said through-hole 313 has an interference fit with the said needle guard 21. A hook 321 is set on the outer edge of the said check valve 32. Two anti-pressing plates 322 are set in the middle part of the check valve. The two anti-pressing plates 322 are set oppositely in a closing shape to form an elongated gap 324 that matches with the said needle guard 21 between their two adjacent end faces. A convex rib 323 is set respectively on the inner sides of the two anti-pressing plates 322 to strength their structural strength. A cavity 331 that matches with the contour of the said check valve 32 is formed at the tail end of the said casing pipe sheath 33. The head end of the said casing pipe sheath 33 extends at its axial direction, and its outer side is set with a nodular and conical bulge 332. The head end of the said casing pipe sheath 33 is in a conical shape. The said check valve 32 is set in the cavity 331 of the casing pipe sheath 33, and the hook 321 of the said check valve 32 is buckled on the opening of the said cavity 331. The said sealing gasket 31 is set on the opening of the cavity 331, and the buckle 311 of the said sealing gasket 31 is buckled on the hook 321 of the check valve 32. The said upper cover 4 is fastened on the opening of the said cavity 331, and the said sealing gasket 31 and the check valve 32 are positioned in the cavity 331 of the casing pipe sheath 33. The said two-way valve 35 is fixed on the said casing pipe sheath 33, and the said two-way valve 35 and the cavity 331 of the said casing pipe sheath 33 are connected each other.

[0081] Refer to FIG. 7: Before puncturing, the power socket of video connecting cable 6 is plugged into power socket of power supply system. One end of the video connecting cable 6 is connected with the camera shooting module 1 on the puncture needle 2 while the other end of the video connecting cable is connected to the input port of display unit 7. The puncture needle 2 is inserted in the said positioning puncture casing pipe 3 to make the puncture needle 2 match with the positioning puncture casing pipe 3. At this moment, the dial piece on the elastic arm 51 rotates at a certain angle with axis of the joint between the elastic arm 51 and the handle 22 under the pressure of the upper cover 34 of the positioning puncture casing pipe 3. The clamping position of elastic arm 51 moves out of the movement direction of the protective rod 23 from the clamping cap 25, and then the clamping cap 25 of the protective rod 23 can move towards one side of the handle 22.

[0082] During puncturing, the transparent cover 4 of the puncture needle 2 overcomes the elastic force of the reset spring 24 and retracts in the needle guard 21 under the resistance from the skin, then the blade 211 of the needle guard 21 exposes. At this moment, the said blade 211 is used to incise the skin tissues to make the puncture needle 2 enter the tissues slowly. Under the lighting of light source, the camera shoot-

ing module 1 can deliver the images for the real-time process of puncturing the tissues and entering the abdominal cavity to the display unit 7 through the video connecting cable. The artery blood vessels such as retroperitoneal aorta and artery blood vessels of abdominal wall cannot be seen effectively. It is operated conveniently and avoids the surgery incidents, which effectively improves the safety and effectiveness of the puncture surgery.

[0083] During puncturing, the transparent cover 4 will reset itself under the spring force of the reset spring 24 as the resistance of the transparent cover 4 disappears. The state that the transparent cover 4 slightly extends out of the positioning puncture casing pipe is recovered to act as a protection function. At this moment, even though the puncturing of abdominal cavity is continued due to misoperation, it can prevent the blade 211 of the needle guard 21 from injuring the visceral organs under the function of the transparent cover 4. This has greatly improved the safety and effectiveness of the puncture surgery. Meanwhile, the nodular and conical bulge 332 of the casing pipe sheath 33 enters the abdominal cavity to have the casing pipe sheath 33 firmly fixed on the abdominal wall under the combined function of contractility formed between the nodular and conical bulge 332 and the incision expansion. The gas can be delivered into the abdominal cavity by connecting the two-way valve 35 and the pneumoperitoneum apparatus so as to maintain the air pressure of abdomen during surgery. Moreover, the principal part of puncture outfit is made with high polymer material. Its disposable use can avoid cross infection and ensure the safe use.

[0084] In this embodiment, the said transparent cover 4 is a round pipe body 41 whose one end is closed. When the closing part 42 of the said round pipe body 41 is in a beveled shape, the tilting angle of its bevel is 20~70 degrees. It has the functions of puncturing and protection. In other embodiments, referring to FIG. 8-9, the closing part 42 of the said round pipe body 41 is in a conical or polygonal pyramid shape and can replace the blade 211 of the needle guard 21 and be directly used for puncturing. Referring to FIG. 10, the closing part 42 of the said round pipe body 41 can be set as a spherical shape. This can effectively prevent extremely easy injuries against the normal tissues of visceral organs when the puncture outfit is inserted in the abdominal cavity, avoid laparoscopic surgery complications such as vascular, intestine and bladder injuries and guarantee the surgery safety and effectiveness.

[0085] As described in the above embodiments for this invention, other puncture outfits and their manufacturing methods by the adoption of the same or similar structures are within the protective scope of this invention.

What is claimed is:

1. A puncture outfit comprising a camera shooting module with a light source, a puncture needle and a positioning puncture casing pipe that matches with the puncture needle; the camera shooting module is set at a head end of the puncture needle; the head end of the puncture needle is sheathed with a transparent cover that can cover the camera shooting module; the puncture needle is inserted in the positioning puncture casing pipe to make the transparent cover at the head end of the puncture needle slightly extend out of the positioning puncture casing pipe.

2. The puncture outfit as set forth in claim 1, wherein the puncture needle comprises a needle guard, a handle, a protective rod and a reset spring; a sleeve joint part that matches with the needle guard is set on a front side wall of the handle;

a tail end of the needle guard is sheathed on the sleeve joint part of the handle to make a head end of the needle guard form a single bevel blade; a tilting angle of the bevel of the single bevel blade is between 20~70 degrees; a mounting rack that matches with the camera shooting module is mounted at a head end of the protective rod; mounting positions that match with the transparent cover are reserved at a head end of the mounting rack; a boss is set in the middle of the protective rod; a tail end of the protective rod is inserted in the needle guard to pass through the sleeve joint part and stretch into the handle; a clamping cap is set at the tail end of the protective rod to prevent the protective rod from moving out of the handle; the reset spring is sheathed at the tail end of the protective rod, and one end of the reset spring presses against the sleeve joint part while another end of the reset spring presses against the boss.

3. The puncture outfit as set forth in claim 2, wherein the puncture needle further comprises a protection mechanism; the protection mechanism comprises an elastic arm; a head end of the elastic arm is fixed in the handle; a middle part of the elastic arm is set with a clamping position that can block the clamping cap to prevent the transparent cover from withdrawing back into the needle guard when the puncture needle is not used; a tail end of the elastic arm extends out from the front side wall of the handle to form a dial piece that presses against the positioning puncture casing pipe to make the clamping position move out of from the clamping cap when the puncture needle is matched with the positioning puncture casing pipe.

4. The puncture outfit as set forth in claim 3, characterized in that the positioning puncture casing pipe comprises a casing pipe sheath, an upper cover, a sealing gasket, a check valve and a two-way valve; a buckle is set on an outer edge of the sealing gasket; a middle part of the sealing gasket has a conical bulge in a side; a through-hole that matches with the needle guard is set at a central position of the bulge; The through-hole has an interference fit with the needle guard; a hook is set on an outer edge of the check valve; two anti-pressing plates are set in the middle part of the check valve; the two anti-pressing plates are set oppositely in a closing shape to form an elongated gap that matches with the needle guard between their two adjacent end faces; a convex rib is set respectively on inner sides of the two anti-pressing plates to strengthen their structural strength; a cavity that matches with a contour of the check valve is formed at a tail end of the casing pipe sheath; a head end of the casing pipe sheath extends at its axial direction, and its outer side is set with a nodular and conical bulge; the head end of the casing pipe sheath is in a conical shape; the check valve is set in the cavity of the casing pipe sheath, and the hook of the check valve is buckled on an opening of the cavity; the sealing gasket is set on the opening of the cavity, and the buckle of the sealing gasket is buckled on the hook of the check valve; the upper cover is fastened on the opening of the cavity, and the sealing gasket and the check valve are positioned in the cavity of the casing pipe sheath; the two-way valve is fixed on the casing pipe sheath, and the two-way valve and the cavity of the casing pipe sheath are connected to each other.

5. The puncture outfit as set forth in claim 4, characterized in that the transparent cover is a round pipe body; one end of the round pipe body is closed; a closing part of the round pipe body is in a beveled, spherical, conical or polygonal pyramid shape; when the closing part of the round pipe body is in a beveled shape, the tilting angle of its bevel is 20~70 degrees.

专利名称(译)	用于腹腔镜检查操作的一次性内窥镜穿刺装备的制造方法和使用该方法的穿刺装备		
公开(公告)号	US20150327886A1	公开(公告)日	2015-11-19
申请号	US14/738945	申请日	2012-08-14
[标]申请(专利权)人(译)	沉振权 苟刘成军 闫治癸 黄镇宁		
申请(专利权)人(译)	沉振权 苟, 刘成军 严, 治痰 黄, 镇宁		
当前申请(专利权)人(译)	沉振权 苟, 刘成军 严, 治痰 黄, 镇宁		
[标]发明人	SHEN ZHENQUAN GOU CHENGJUN YAN ZHITAN HUANG ZHENNING		
发明人	SHEN, ZHENQUAN GOU, CHENGJUN YAN, ZHITAN HUANG, ZHENNING		
IPC分类号	A61B17/34 A61B1/05 A61B1/018		
CPC分类号	A61B17/3478 A61B17/3496 A61B1/05 A61B1/018 A61B1/00087 A61B1/0011 A61B17/3417 A61B90/361 A61B2017/00907 A61B2017/3454 Y10T29/49826		
优先权	201110338794.9 2011-11-01 CN 14/002739 2013-09-03 US		
外部链接	Espacenet USPTO		

摘要(译)

提供了一种用于腹腔镜检查操作的一次性内窥镜穿刺装备的制造方法以及根据该方法制造的穿刺装备。穿刺装备具有带光源的摄像模块，穿刺针和与穿刺针配合的定位穿刺套管；相机拍摄模块设置在穿刺针的头端；穿刺针的头端套有透明盖，可覆盖摄像模块；将穿刺针插入定位穿刺套管中，使穿刺针头端的透明盖稍微伸出定位穿刺套管。穿刺装备可用于通过相机拍摄模块进行可见的外科手术。

