



(19) **United States**

(12) **Patent Application Publication**  
**POLL et al.**

(10) **Pub. No.: US 2012/0310147 A1**

(43) **Pub. Date: Dec. 6, 2012**

(54) **DEVICES, SYSTEMS, AND METHODS FOR PERFORMING ENDOSCOPIC SURGICAL PROCEDURES**

**Publication Classification**

(51) **Int. Cl.**  
*A61M 13/00* (2006.01)  
*A61B 17/34* (2006.01)

(75) Inventors: **WAYNE L. POLL**, New Albany, OH (US); **GREGORY DRACH**, Liberty Township, OH (US)

(52) **U.S. Cl.** ..... **604/24; 604/26; 604/164.11**

(73) Assignee: **MINIMALLY INVASIVE DEVICES, LLC**, Columbus, OH (US)

(57) **ABSTRACT**

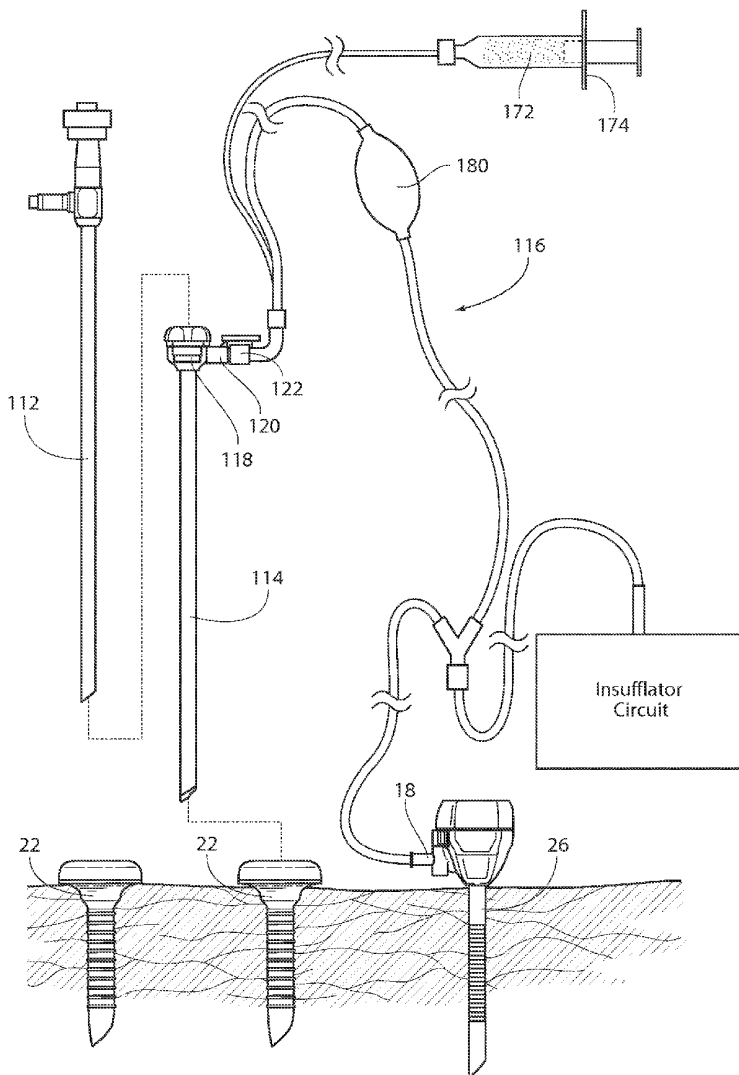
(21) Appl. No.: **13/311,085**

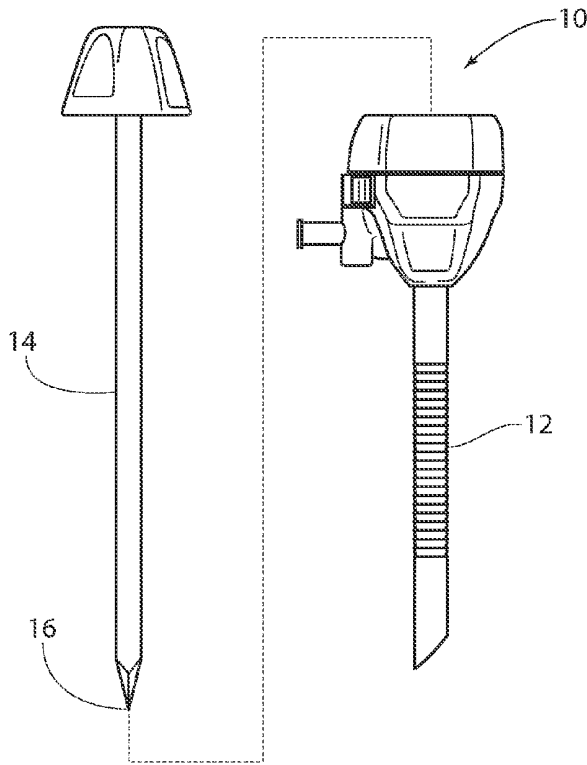
Methods and systems for accessing an operating cavity when performing endoscopic surgery comprising. The systems and methods include at least one obturator-free cannula unit and a trocar assembly. The trocar assembly includes a single dedicated functional obturator independent of the cannula unit and an endoscopic cannula. The invention also provides a system and methods for providing continuous flow of carbon dioxide during a laparoscopic procedure.

(22) Filed: **Dec. 5, 2011**

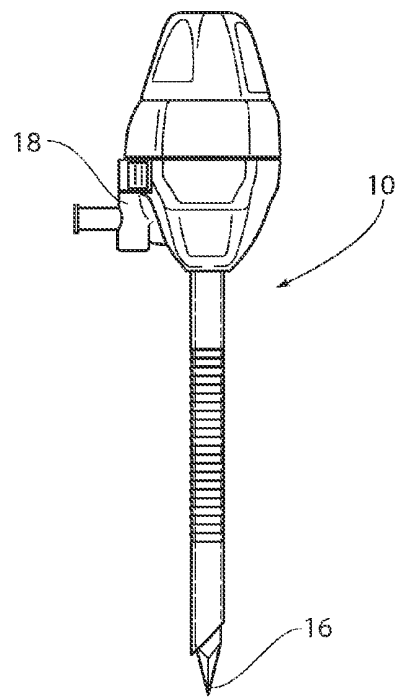
**Related U.S. Application Data**

(60) Provisional application No. 61/419,357, filed on Dec. 3, 2010.

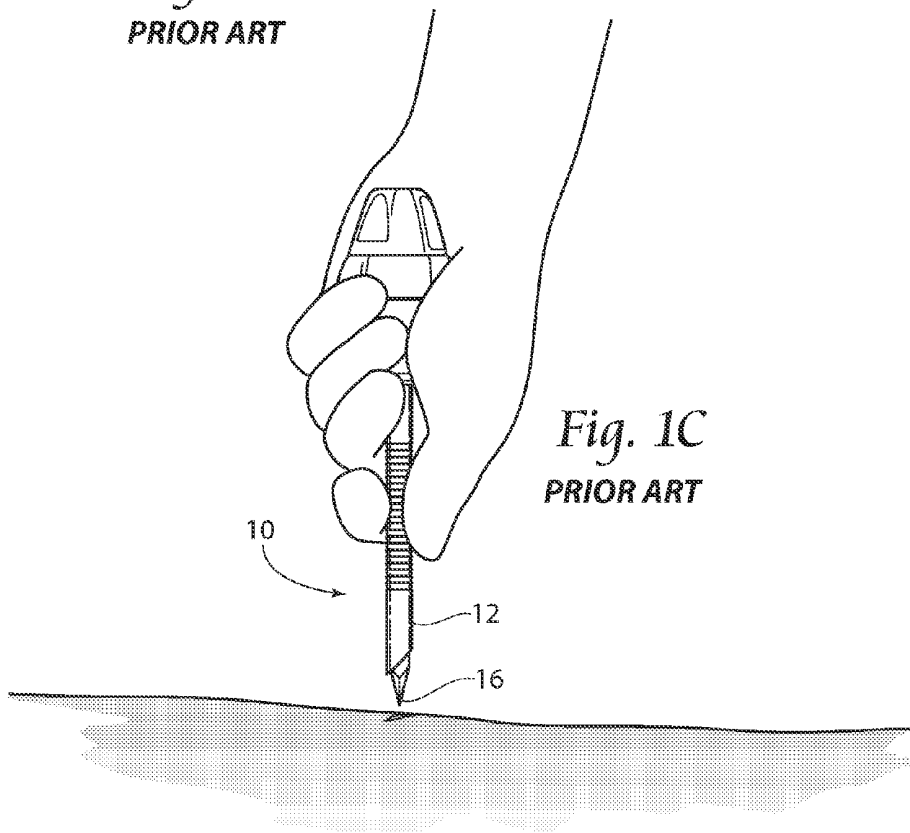




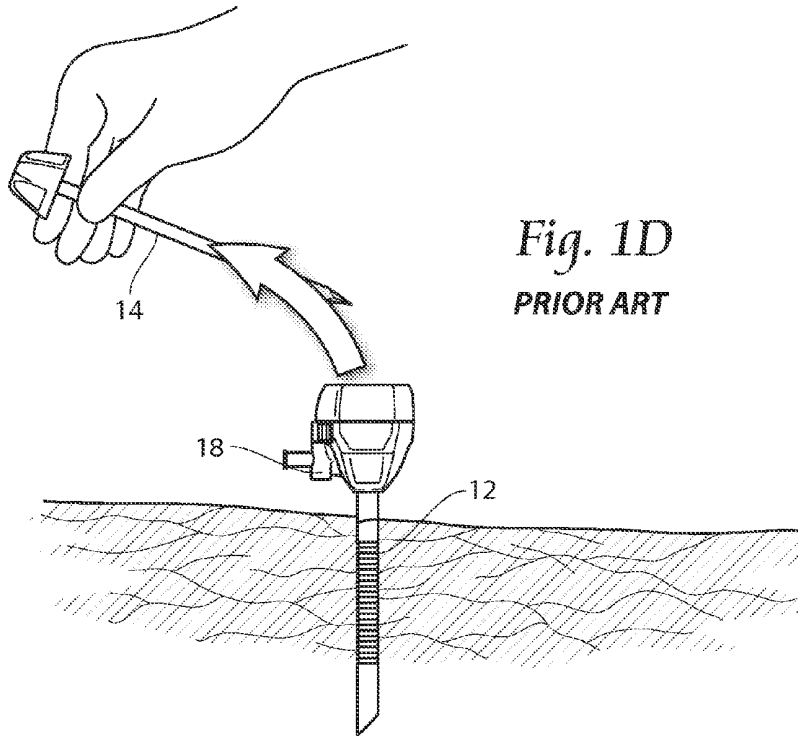
*Fig. 1A*  
PRIOR ART



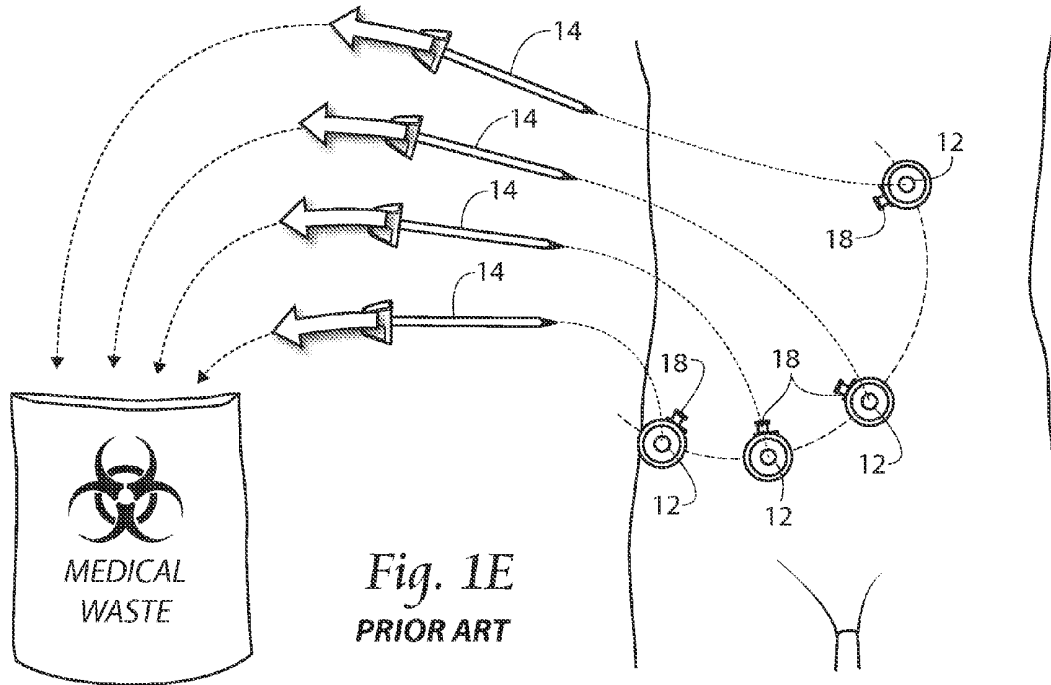
*Fig. 1B*  
PRIOR ART



*Fig. 1C*  
PRIOR ART



*Fig. 1D*  
**PRIOR ART**



*Fig. 1E*  
**PRIOR ART**

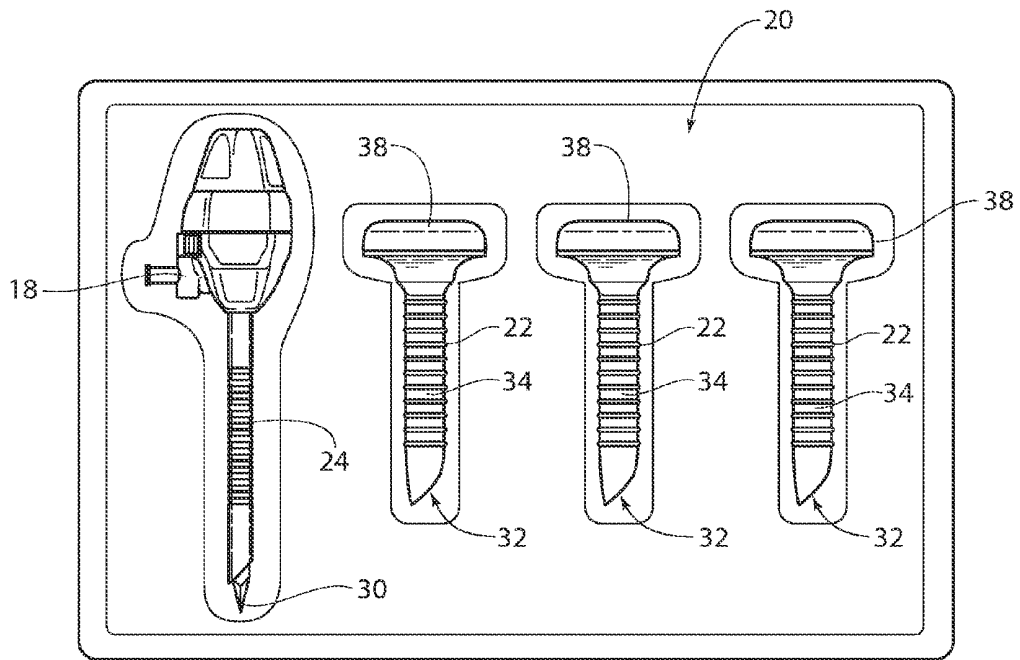


Fig. 2

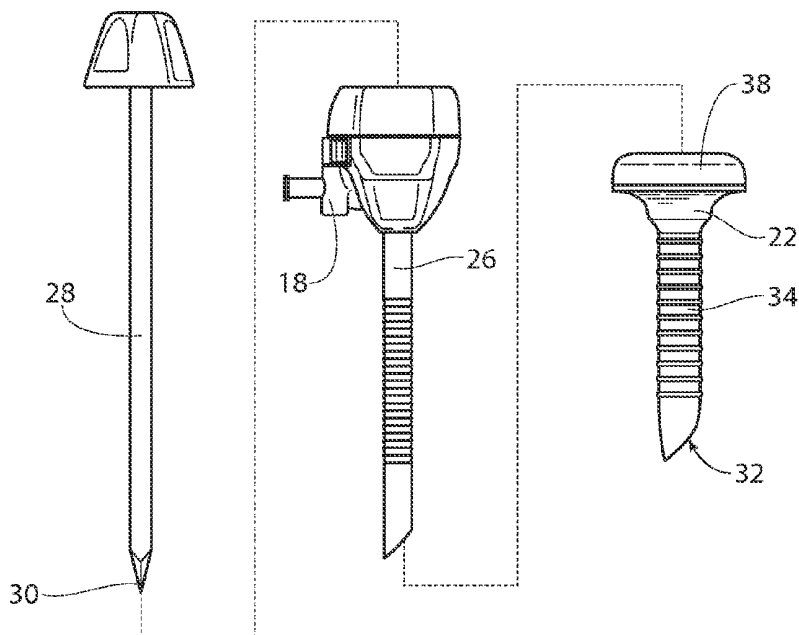
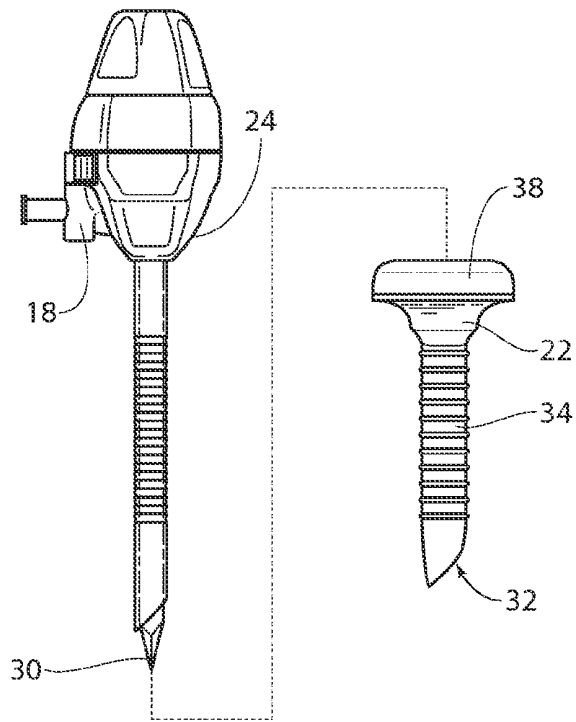
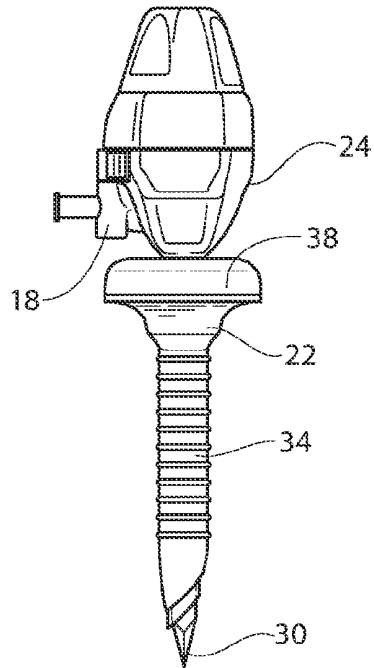


Fig. 3A

*Fig. 3B*



*Fig. 3C*



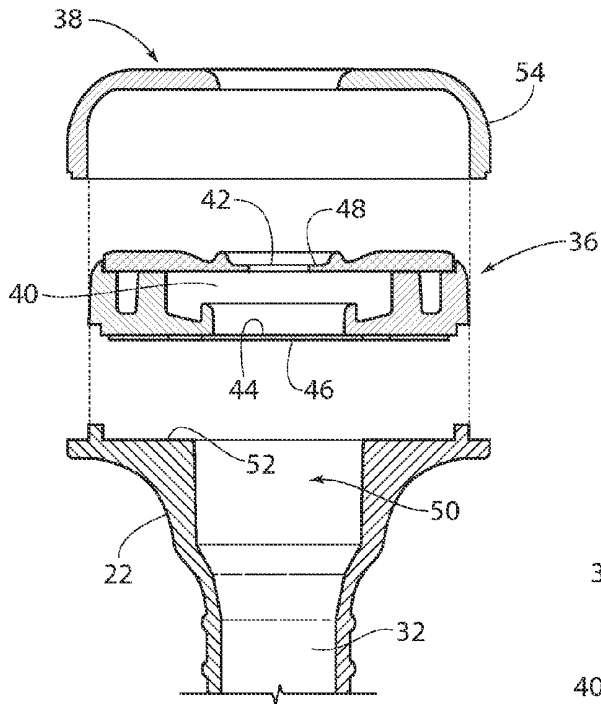


Fig. 4A

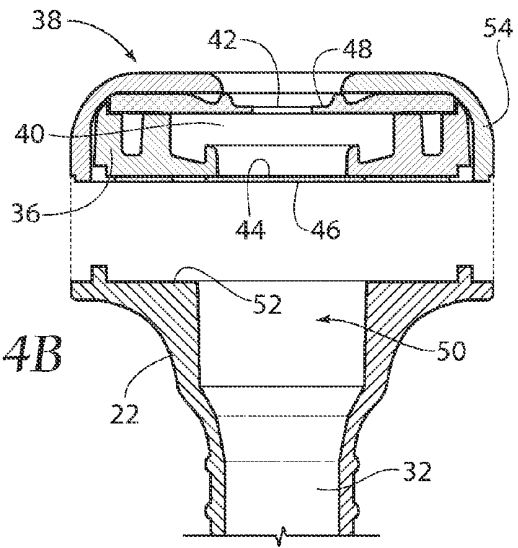


Fig. 4B

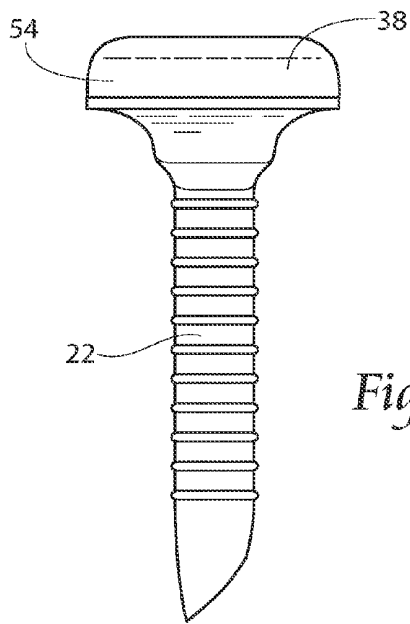


Fig. 4C

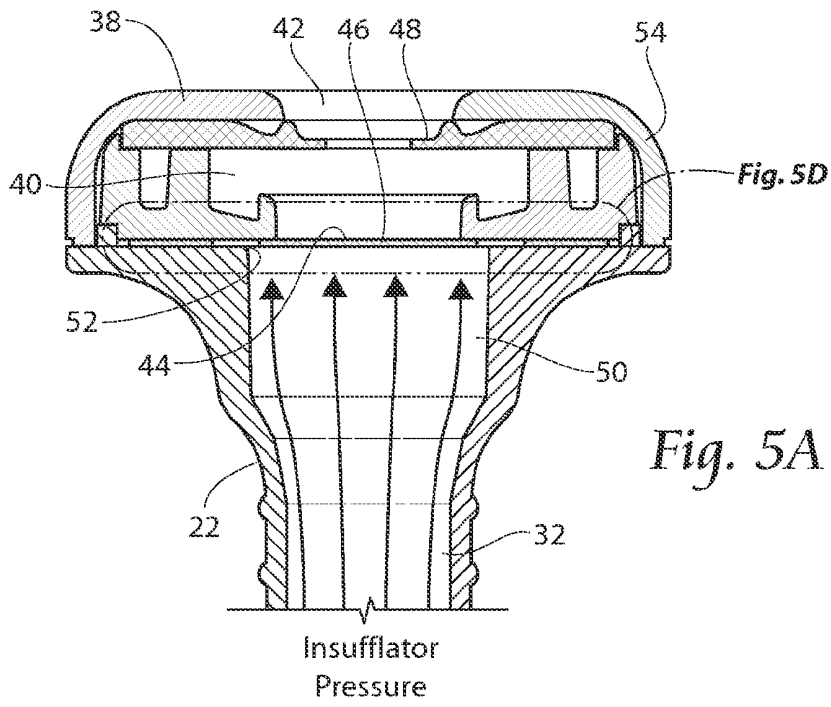


Fig. 5A

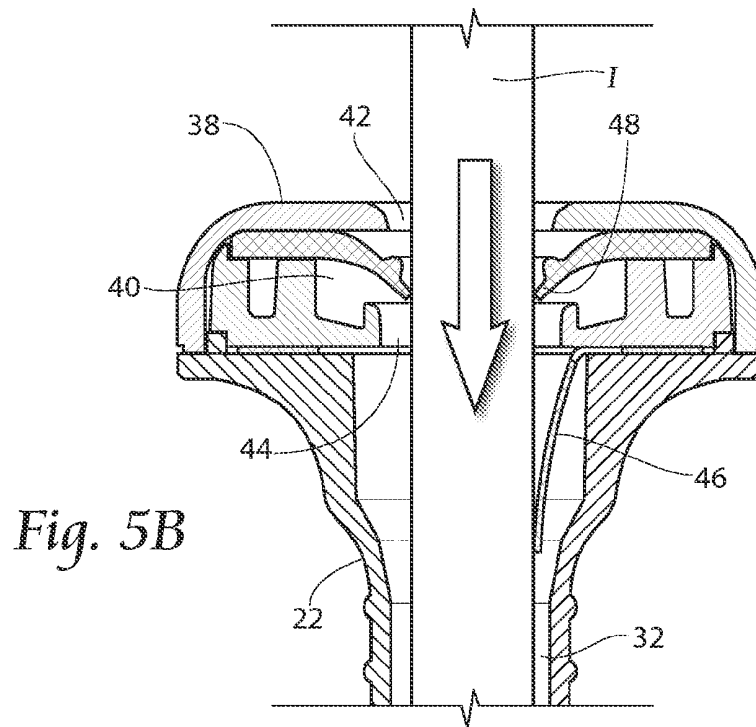


Fig. 5B

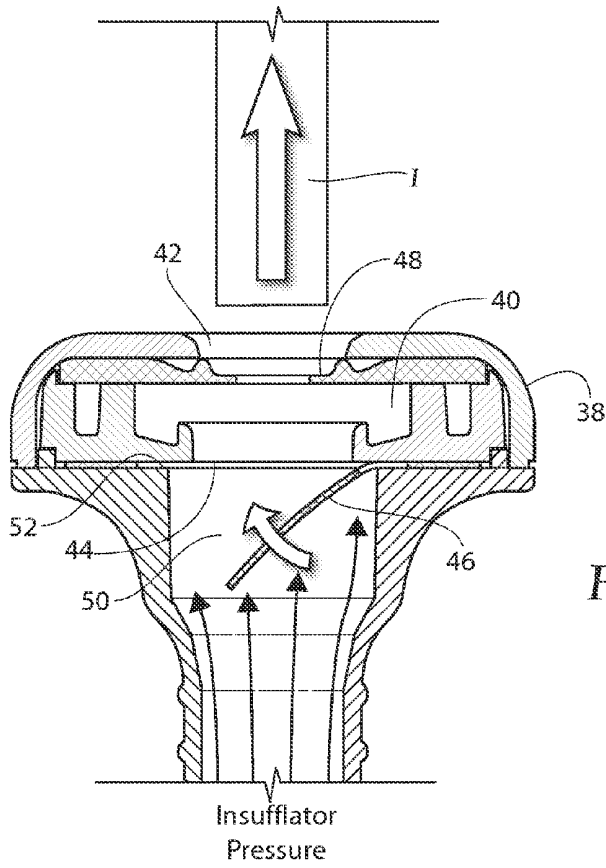


Fig. 5C

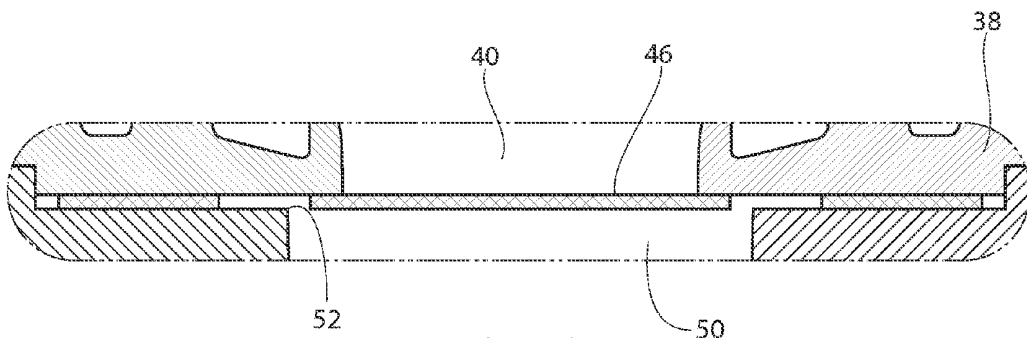
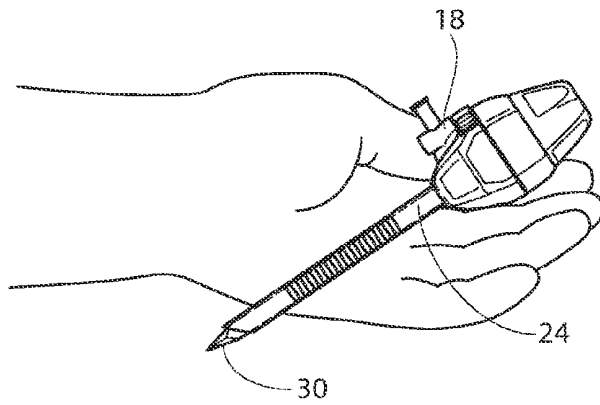
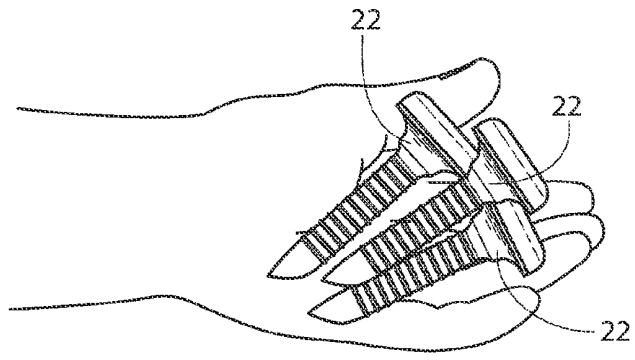


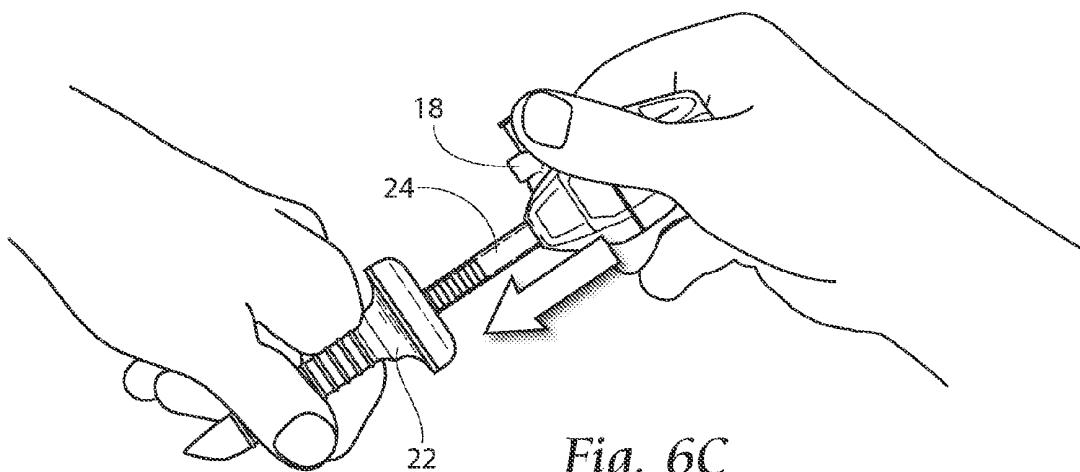
Fig. 5D



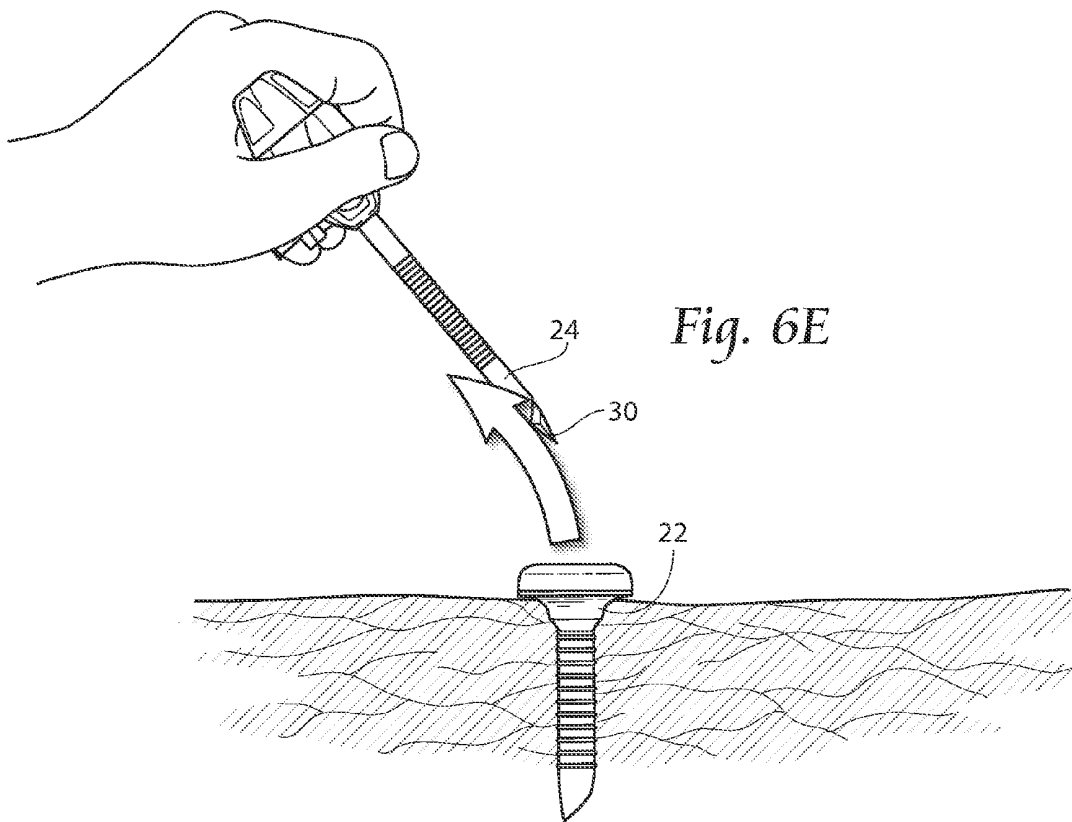
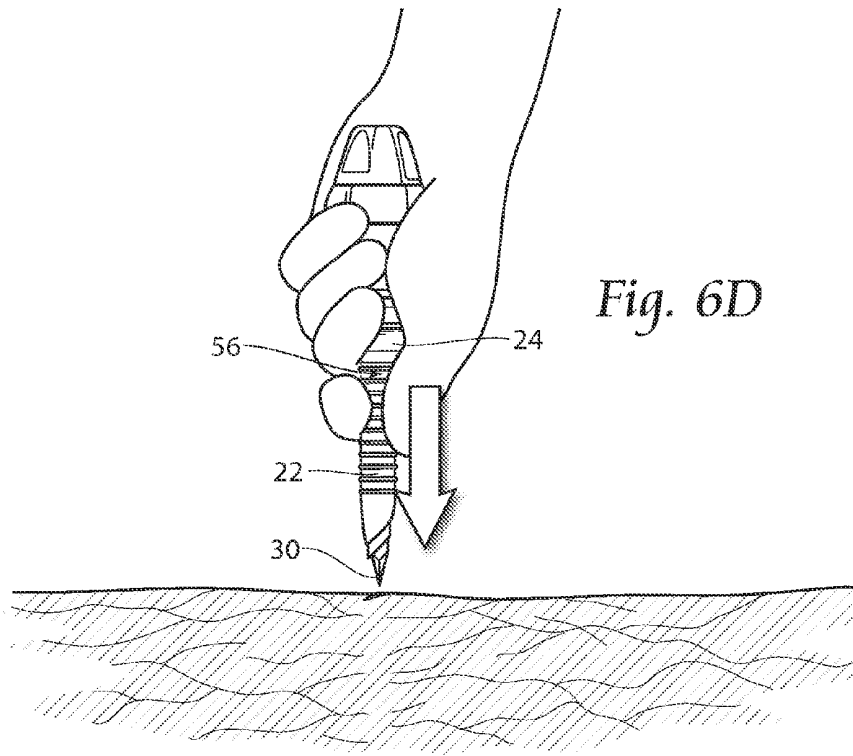
*Fig. 6A*



*Fig. 6B*



*Fig. 6C*



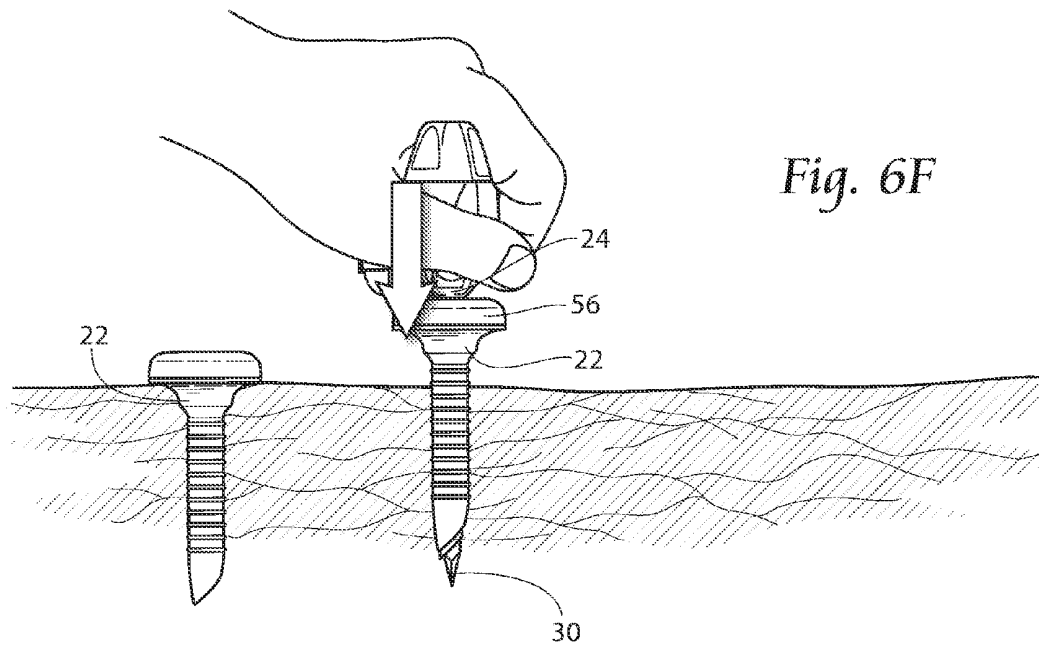


Fig. 6F

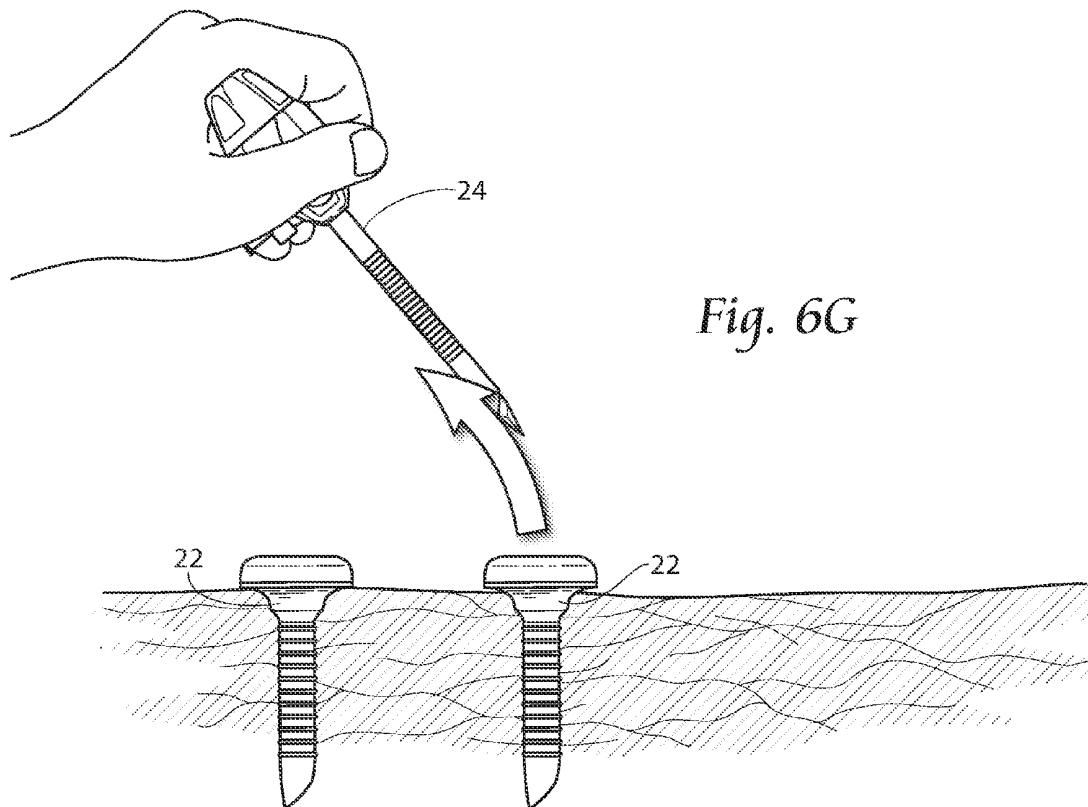


Fig. 6G

Fig. 6H

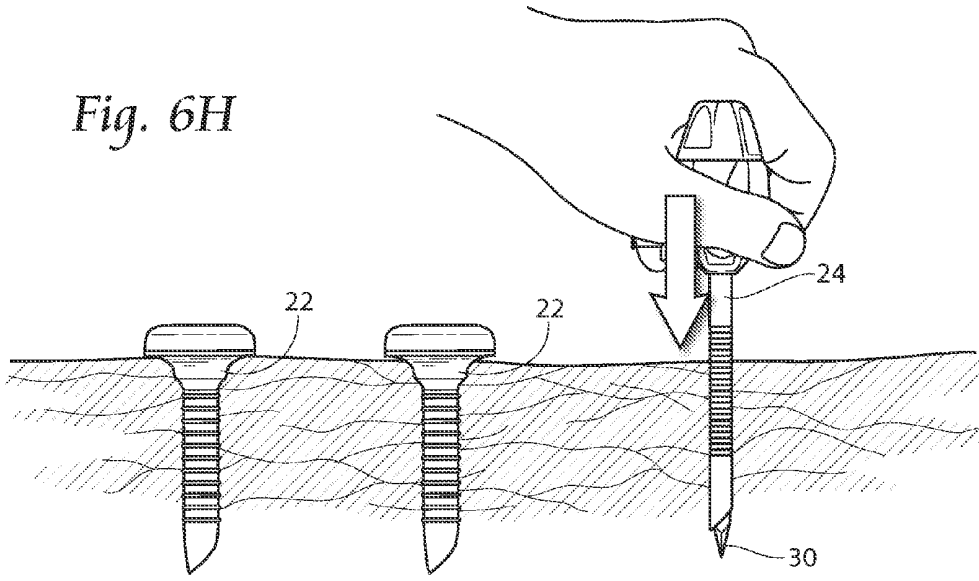
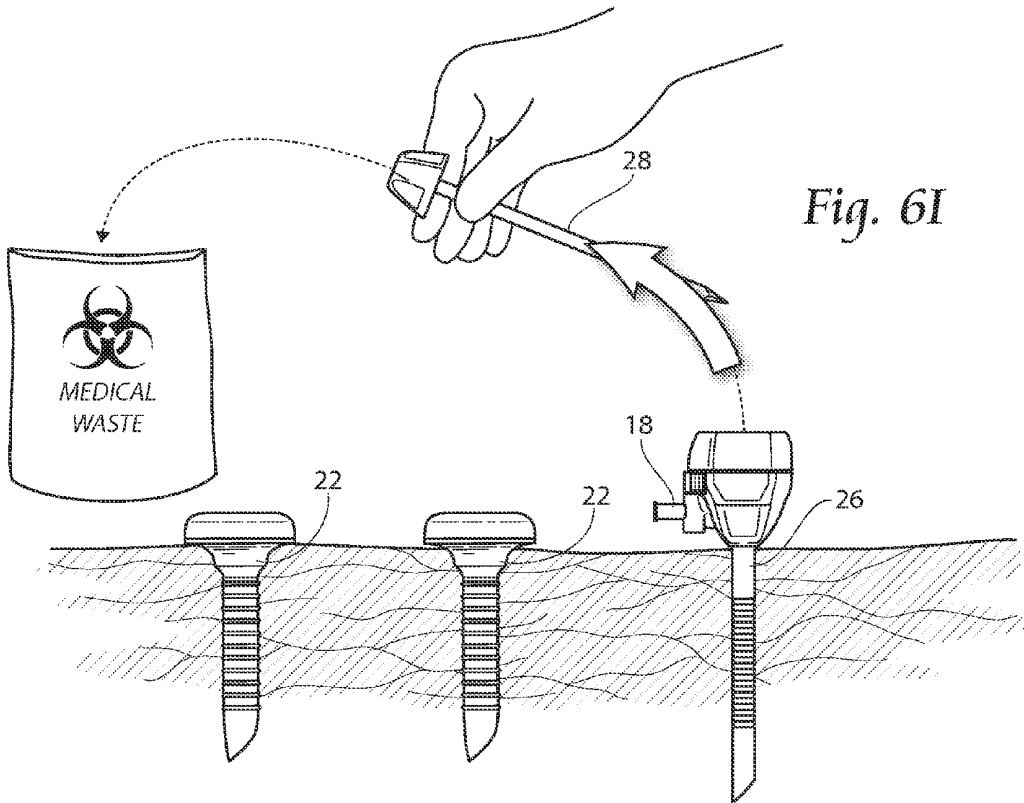


Fig. 6I



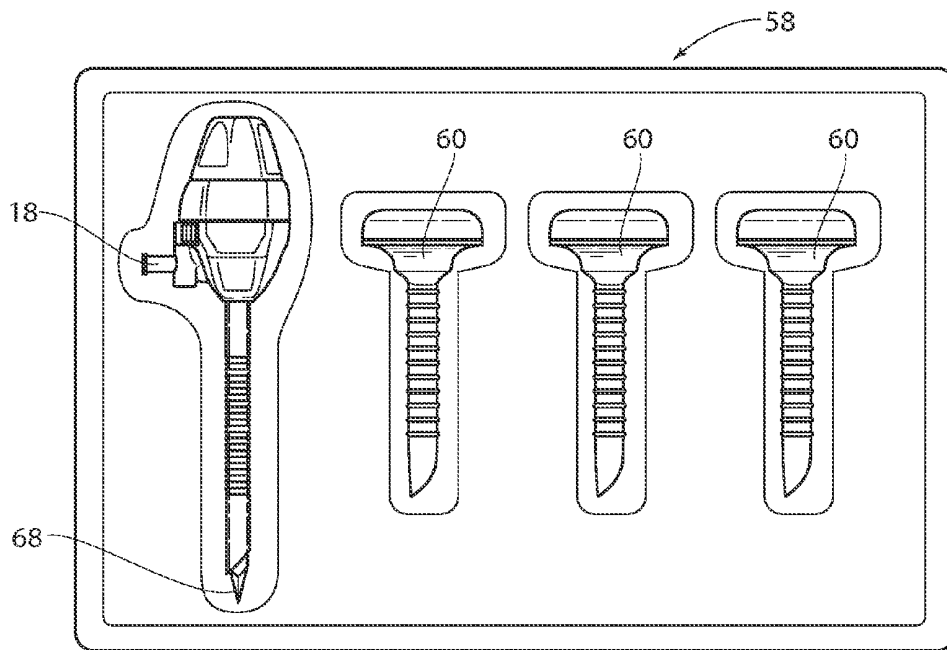


Fig. 7

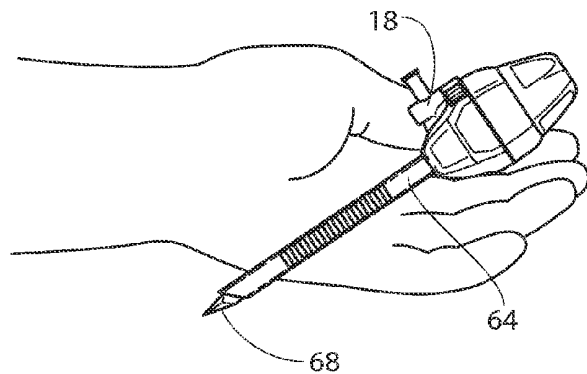
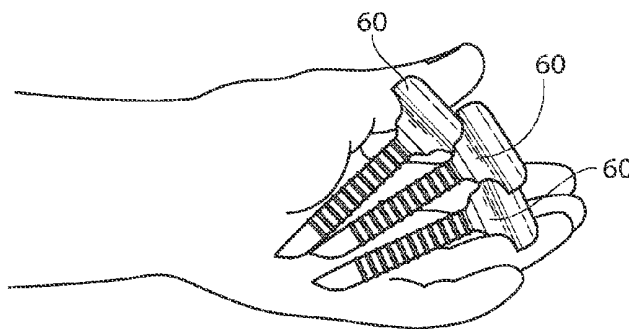
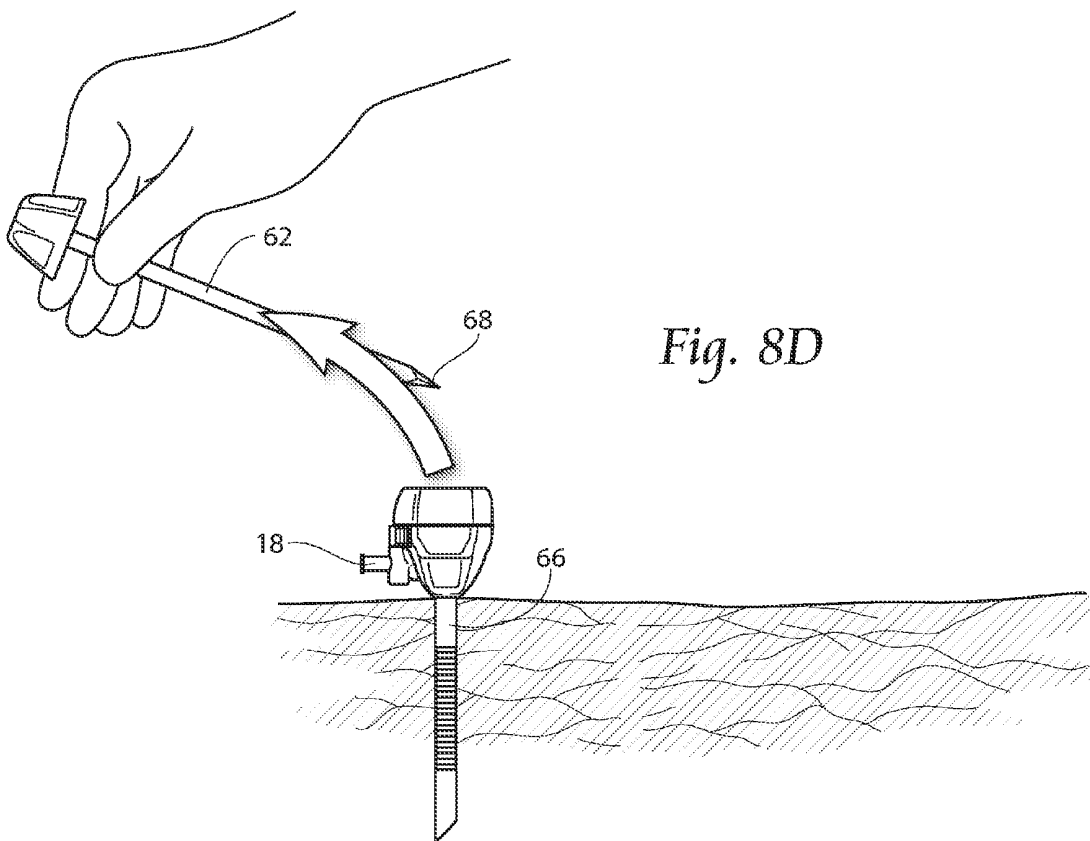
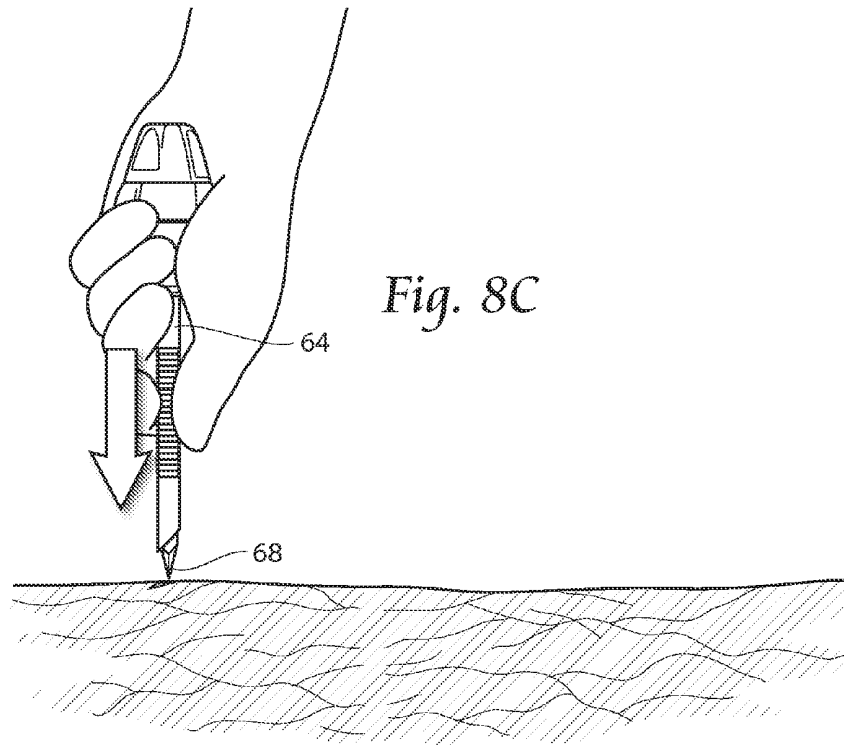


Fig. 8A

Fig. 8B





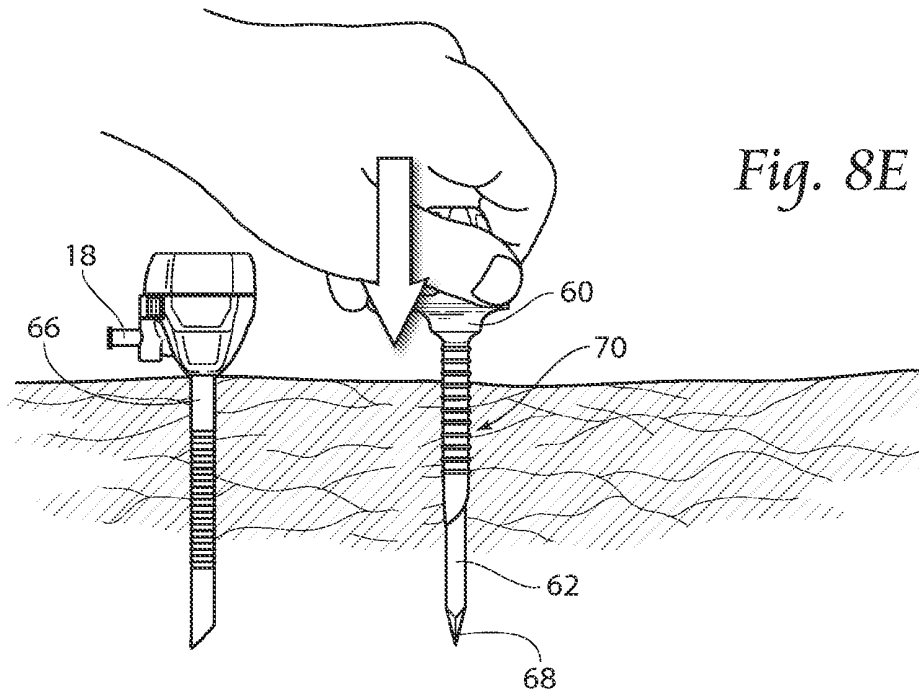


Fig. 8E

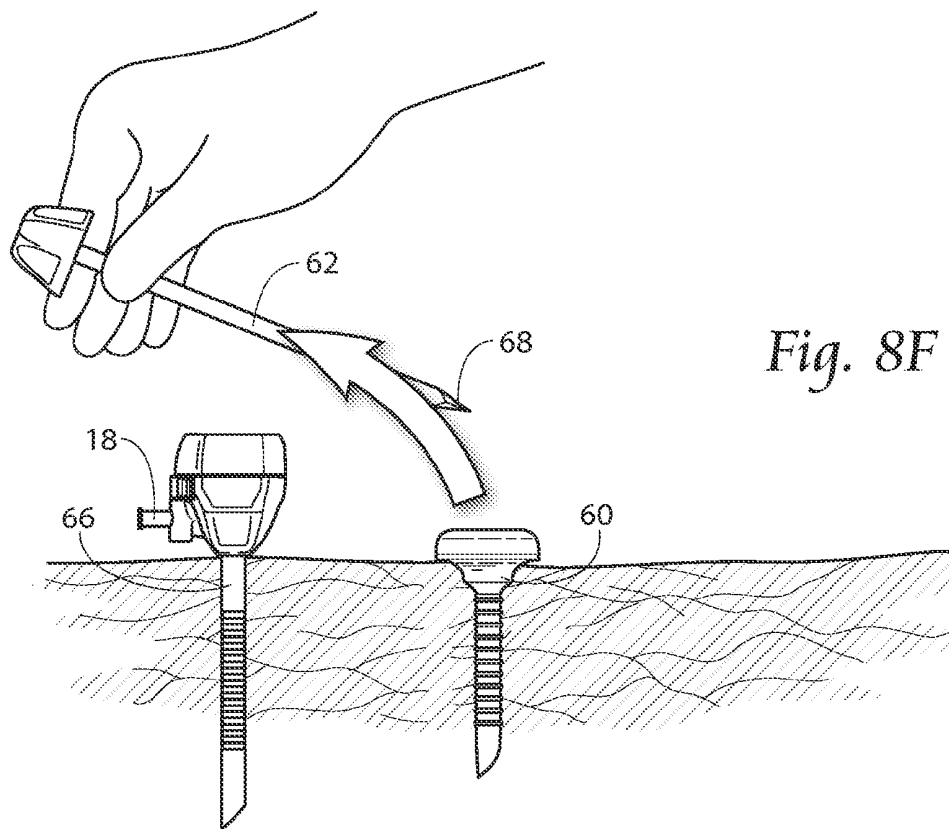


Fig. 8F

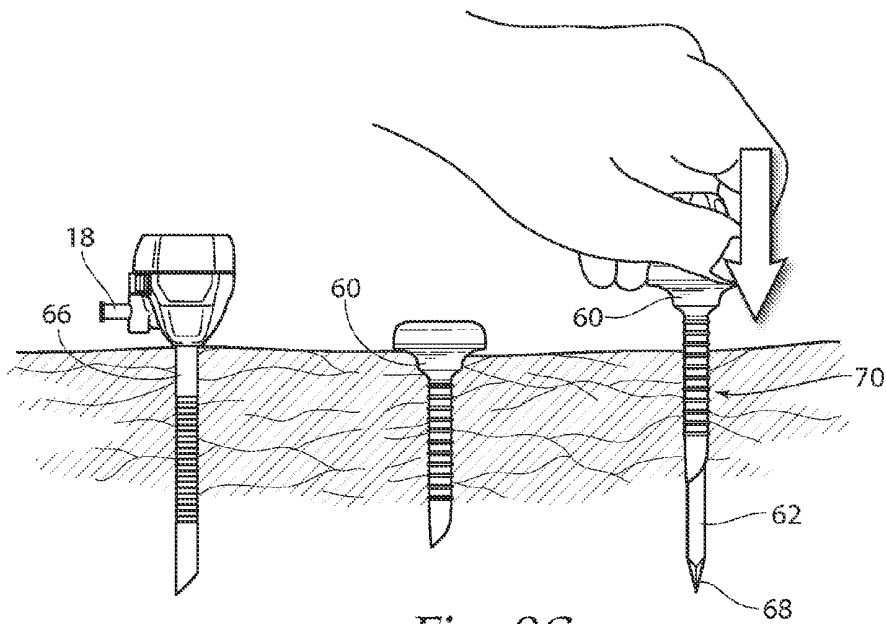


Fig. 8G

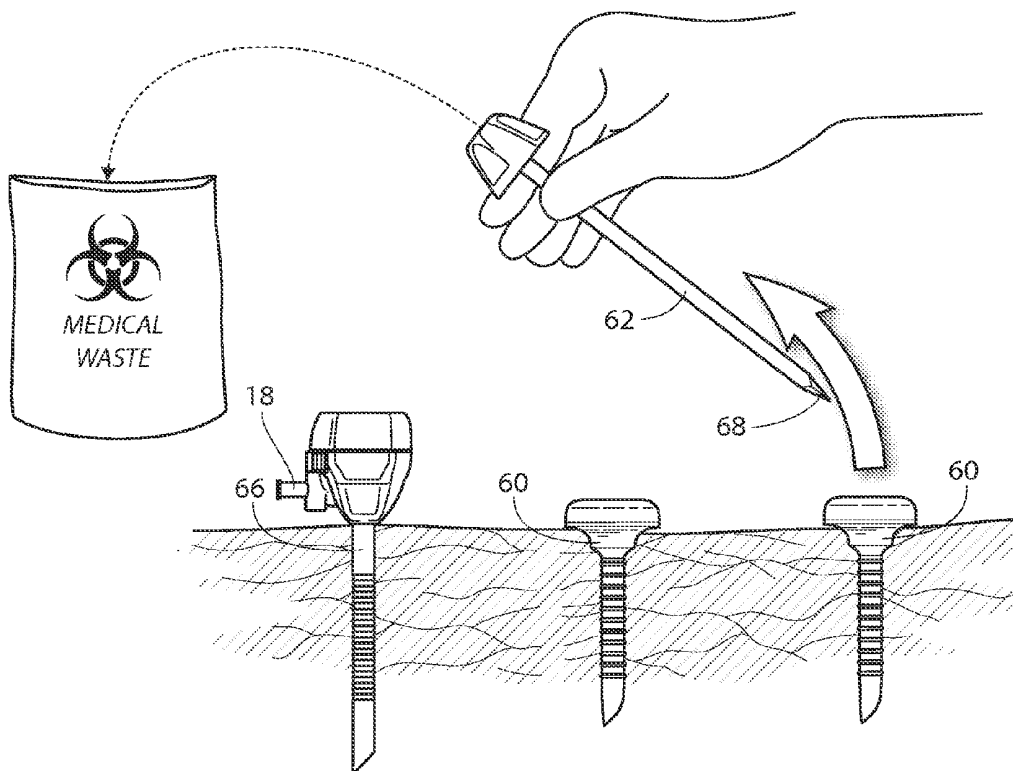


Fig. 8H

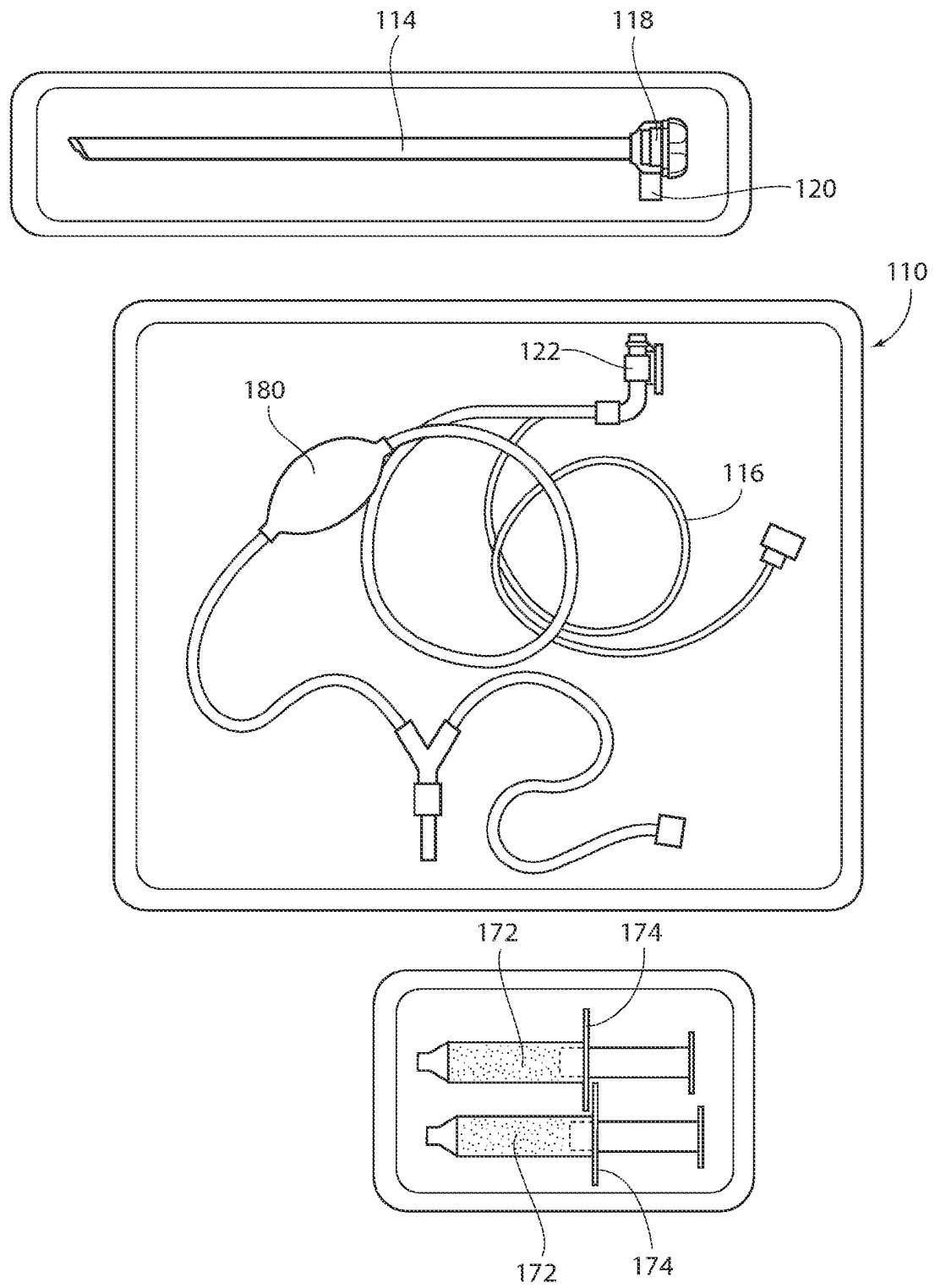


Fig. 9

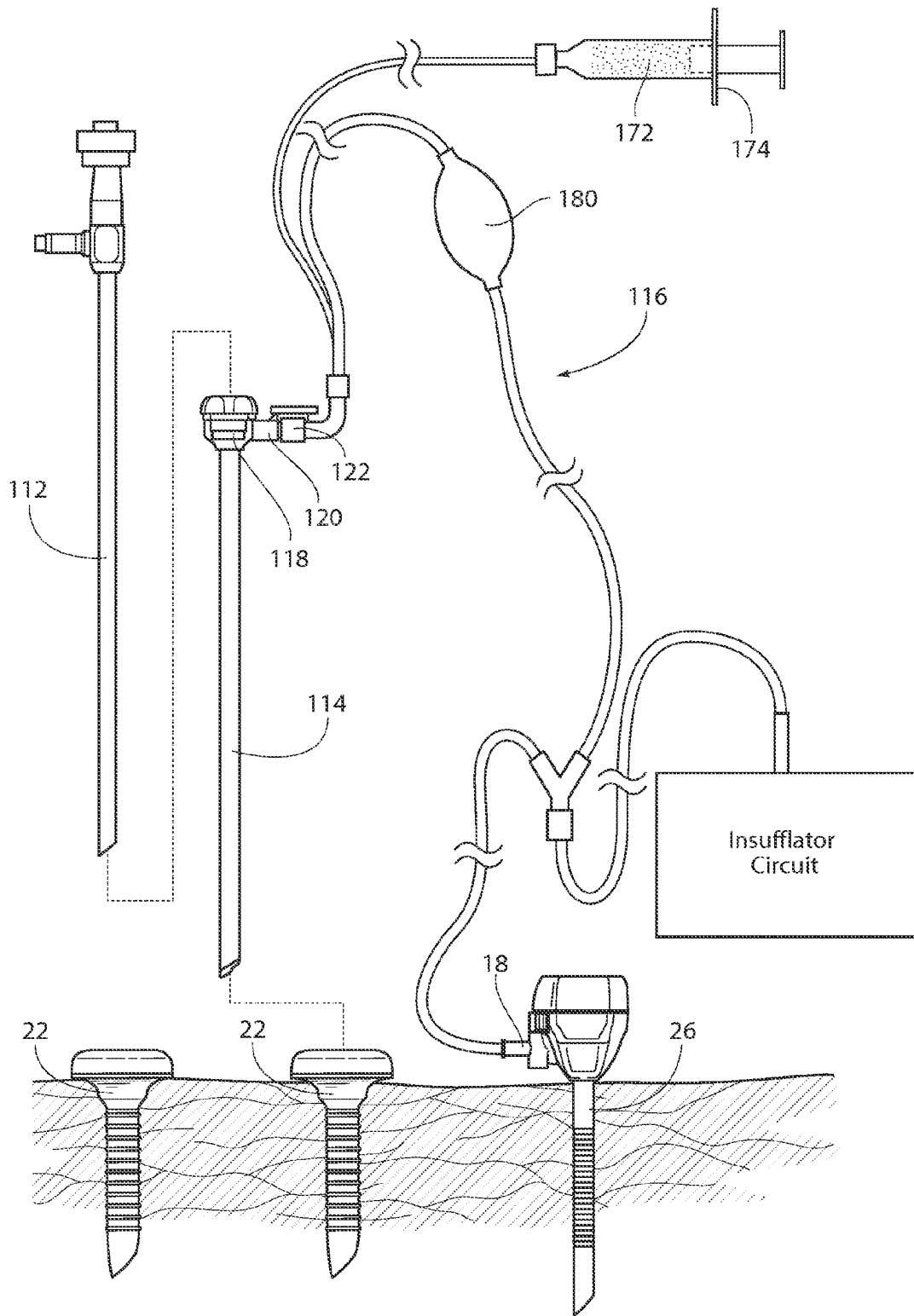
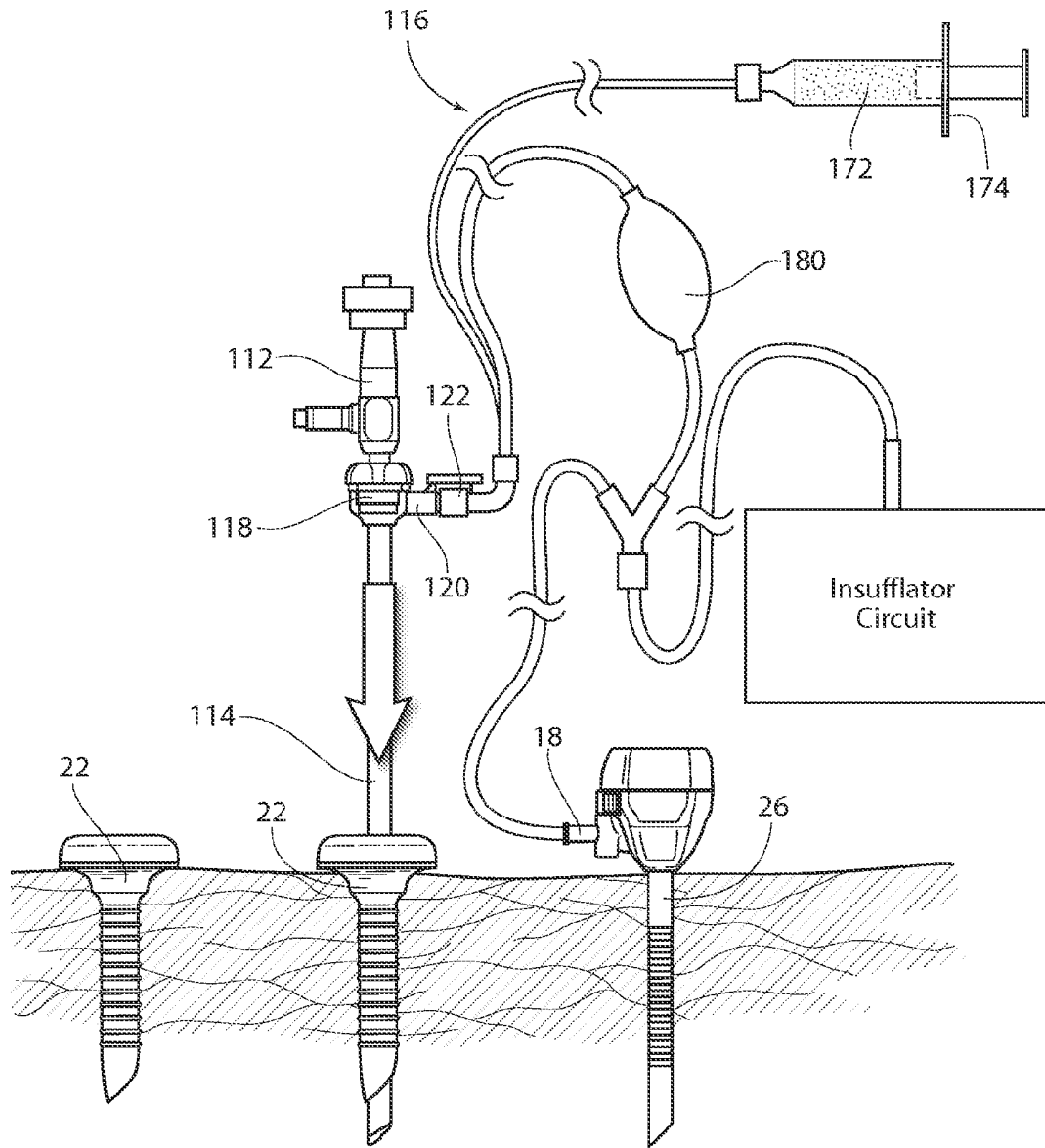


Fig. 10A



*Fig. 10B*

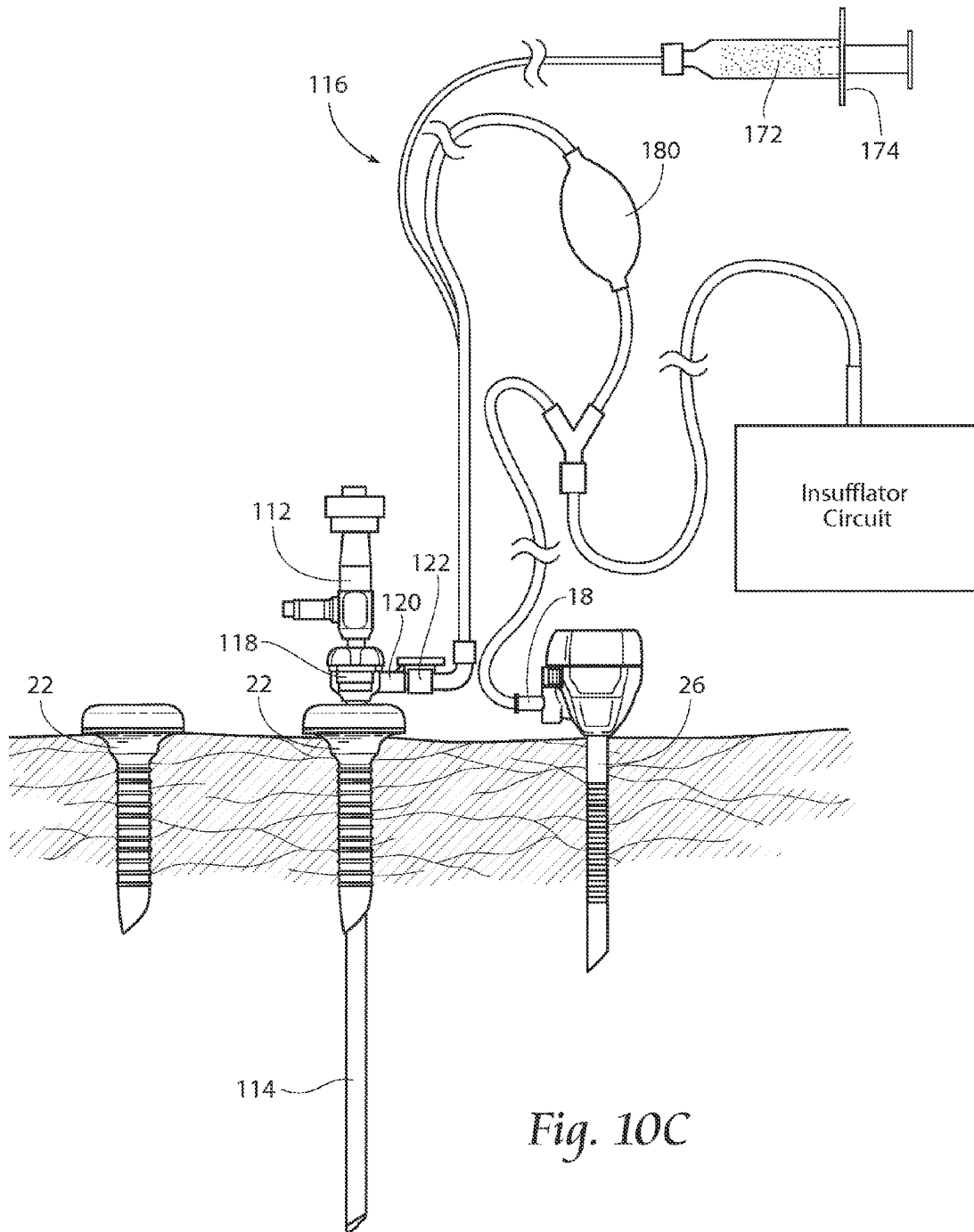


Fig. 10C

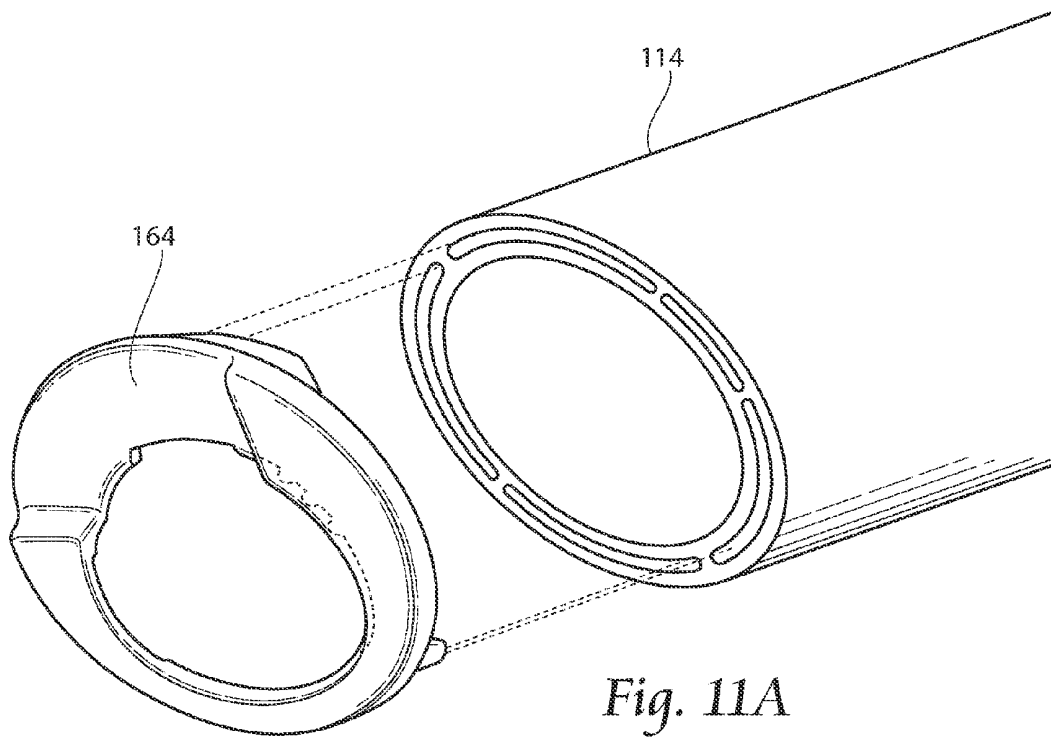


Fig. 11A

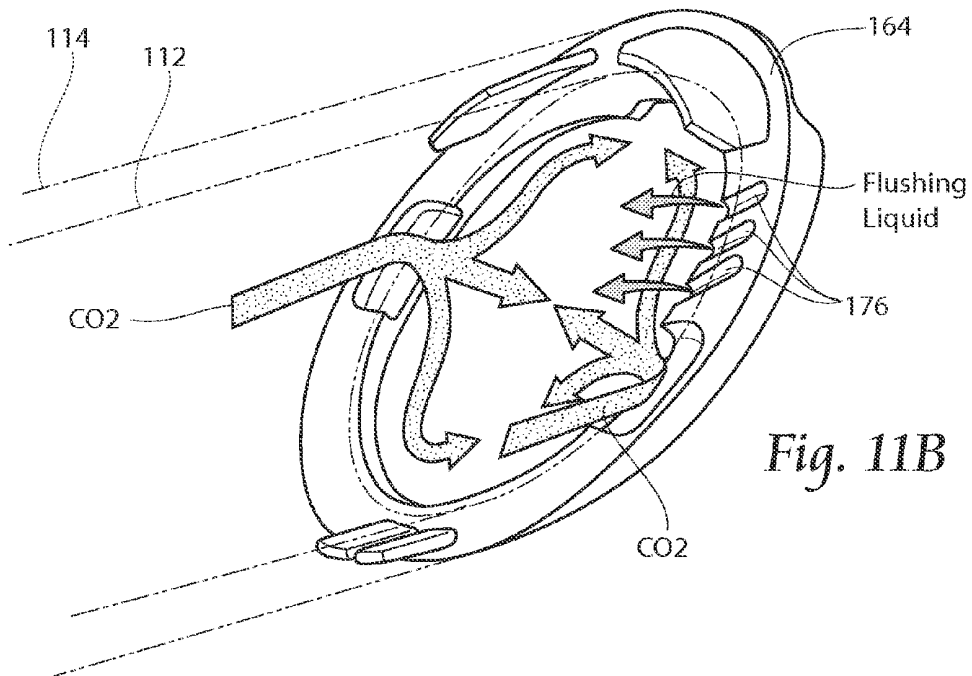
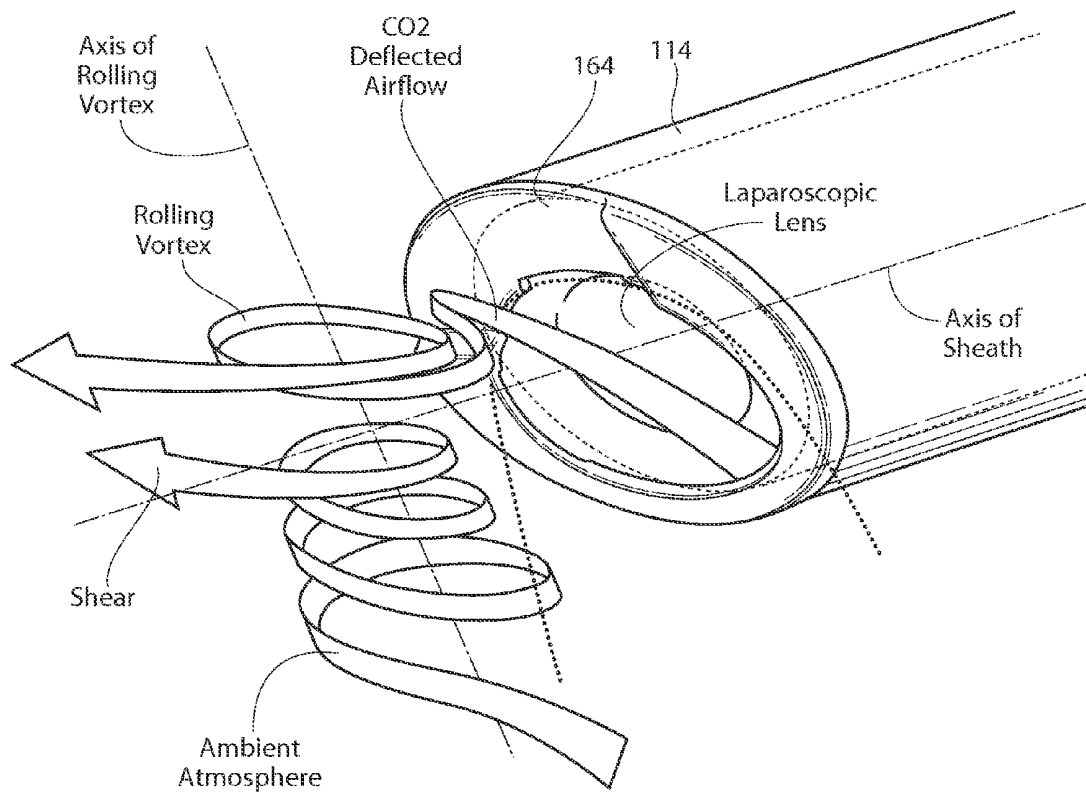


Fig. 11B



*Fig. 11C*

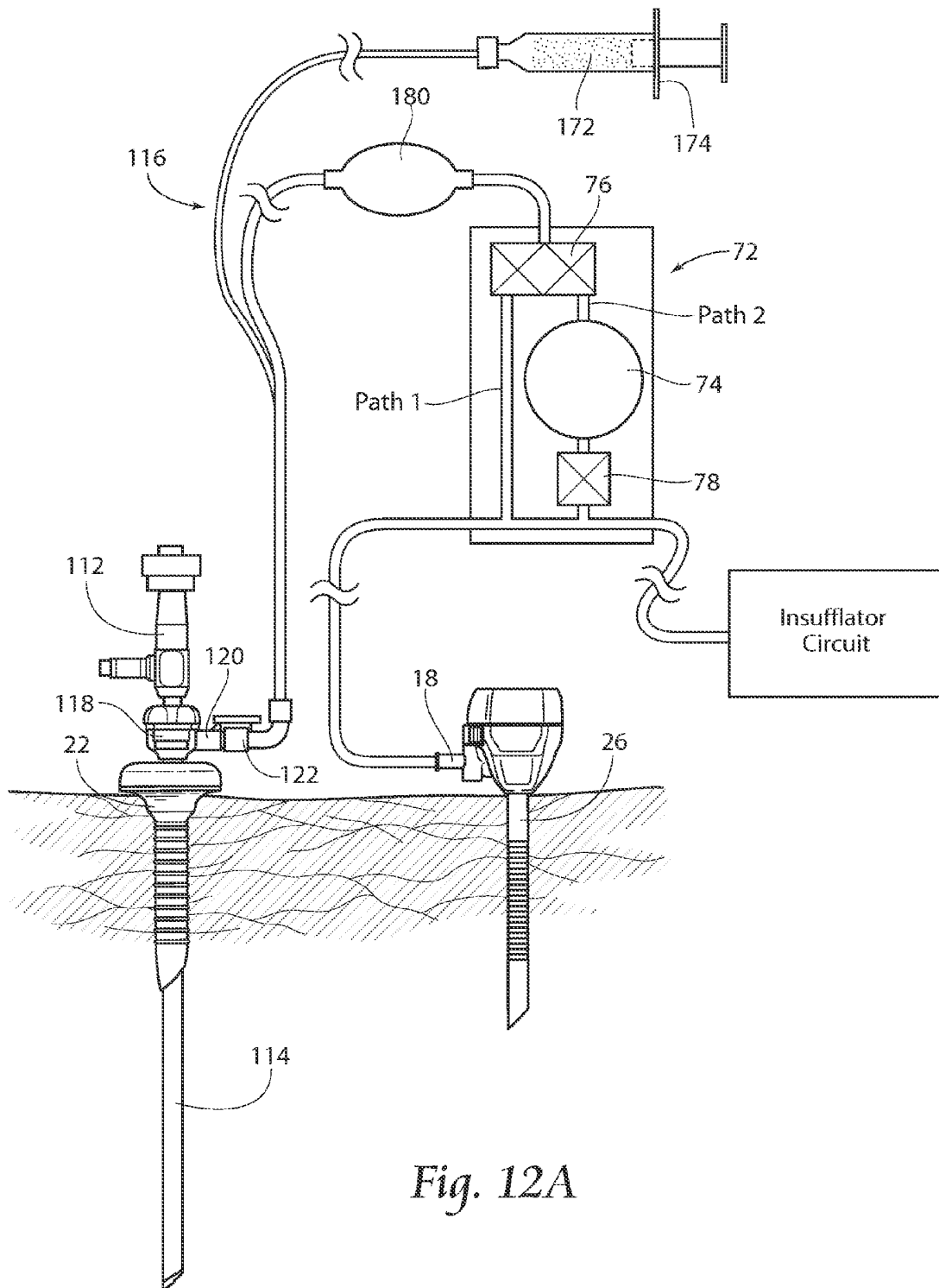


Fig. 12A

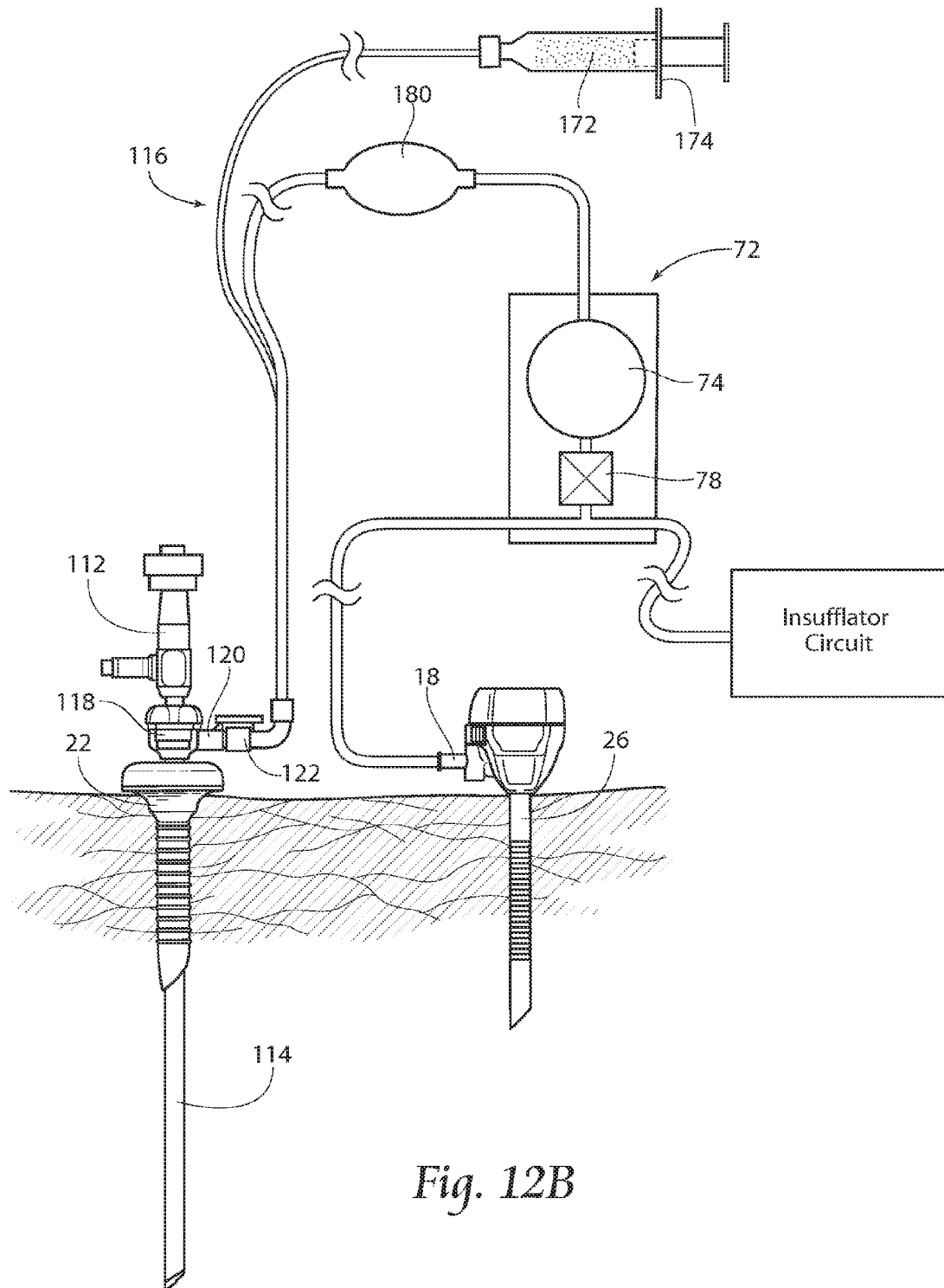


Fig. 12B

## DEVICES, SYSTEMS, AND METHODS FOR PERFORMING ENDOSCOPIC SURGICAL PROCEDURES

### RELATED APPLICATION

[0001] This application claims the benefit of provisional patent application Ser. No. 61/419,357 filed 3 Dec. 2010.

### FIELD OF THE INVENTION

[0002] The invention generally relates to devices, systems, and methods for performing endoscopic surgical procedures.

### BACKGROUND OF THE INVENTION

[0003] Endoscopic surgery (also called keyhole surgery) encompasses modern, minimally invasive surgical procedures, in which access to the surgical field is gained through relatively small incisions. Endoscopic surgery includes laparoscopic procedures, which are performed within the abdominal or pelvic cavities. Endoscopic surgery also includes thoracoscopic procedures, which are performed on the thoracic or chest cavity.

[0004] Minimally invasive surgical procedures are desirable because they make possible reduced blood loss; reduced post-operative patient discomfort; shortened recovery and hospitalization time; and reduced exposure of internal organs to possible contaminants.

[0005] In laparoscopic surgery, for example, operations in the abdomen are performed through relatively small incisions (usually 0.5-1.5 cm).

[0006] During laparoscopic surgery, the abdomen is inflated using CO<sub>2</sub> gas provided by an insufflation circuit. The CO<sub>2</sub> elevates the abdominal wall above the internal organs like a dome to create a working and viewing space for the surgery.

[0007] One key element in laparoscopic surgery is an assembly called a laparoscopic trocar (which, in short hand, will be called an "LT"). A conventional LT **10** is shown in FIGS. 1A and 1B. The LT **10** is an access device used to penetrate the wall of the abdominal cavity to provide access for the introduction of CO<sub>2</sub> insufflation gas; the manipulation of surgical instruments; and the insertion of optics (called laparoscopes) to observe the operating field while surgery is performed. A conventional LT **10** is typically treated as a single use, disposable item.

[0008] A conventional LT **10** consists of two parts (see FIG. 1A): a cannula **12** and an obturator **14**.

[0009] The cannula **12** is a tubular sleeve that defines an access path or lumen to the operating field. The cannula typically includes a self-contained "air-lock" mechanism within the lumen, which provides access for surgical instruments and optics through the cannula, while preventing the escape of CO<sub>2</sub> introduced into the abdominal cavity, so the cavity stays inflated.

[0010] According to existing laparoscopic surgical preference and practice, conventional laparoscopic surgical instruments and laparoscopes are typically sized and configured in one of three standard exterior diameters, the smallest being about 5 mm, the next larger being about 10 mm, and the largest being about 12 mm. Due to inventory and cost issues, the conventional LT's incorporate cannulas **12** accordingly sized in a range of standard interior diameters to accommodate the smooth and airtight passage of the conventional 5 mm, or 10 mm, or 12 mm instruments. This hierarchy of

cannula sizes for conventional LT's imposes limitation upon the use of specialized instruments having desirable added functional benefits, but which increase the exterior diameter of the instrument.

[0011] The obturator **14** is an elongated pointed cylinder with a sharpened, tissue-penetrating tip. The obturator **14** is sized and configured to fit within the lumen of a conventionally-sized cannula **12**, with the penetrating tip **16** protruding from the open end of the cannula lumen, as FIG. 1B shows. The protruding, penetrating tip **16** of the obturator **14** incises or separates tissue on entry so as to allow body penetration.

[0012] In conventional usage, the LT **10** is supplied as an assembled unit, as shown in FIG. 1B, including the cannula **12** and a dedicated obturator **14** inserted through the lumen of the cannula. To penetrate the abdominal wall, the surgeon manipulates the cannula **12** and dedicated obturator **14** as a single assembled unit (see FIG. 1C). Once penetration has been made, the dedicated obturator **14** is withdrawn (see FIG. 1D), opening the lumen of the cannula **12** for passage of instruments or optics.

[0013] Since conventional LT's are typically treated as single use items, after each obturator **14** is withdrawn from its companion cannula **12** as just described, the obturator **14** is not used again during the procedure. It is discarded as medical waste. Theoretically, an obturator **14** (and companion cannula **12**) could, if desired, be reprocessed for use in a subsequent procedure, but, according to conventional wisdom, many surgeons and surgical teams nevertheless resist reusing devices intended for single use that, even though reprocessed, have been inside a previous patient.

[0014] Typically, during a single laparoscopic procedure, several, separate LT's (each comprising a cannula **12** and its own dedicated obturator **14**) are inserted (see FIG. 1E). For example, at least one LT **10** is inserted for the introduction of CO<sub>2</sub> insufflation gas (the cannula **12** includes a stopcock **18** communicating with a passage in the cannula **12**, to which an insufflation line can be coupled); one or more LT's are inserted for passage of surgical instruments; and at least one LT is inserted for the passage of a laparoscope. The separate LT's (each comprising a cannula **12** and its dedicated obturator **14**) are inserted individually, one at a time, in sequence, to provide the desired number of abdominal penetrations; and, in sequence, the withdrawn obturators **14** are put aside, one at a time, for disposal. Thus, at the end of the procedure (see FIG. 1E), the number of obturators **14** that are discarded as medical waste equals the number of cannulas **12** that form the abdominal penetrations.

### Technical Features of the Invention

[0015] One aspect of the invention provides a simplified system and method for performing an endoscopic surgical procedure. The system and method are particularly well suited for use, e.g., in a situation in which it is desirable to make use of a specialized endoscopic instrument, which provides one or more desirable functional benefits, but which possesses a marginally increased exterior diameter that does not readily fit the cannula sizes used by conventional LT's.

[0016] The system and method include a single or a plurality of individual endoscopic cannula units to provide an array of access sites for minimally invasive endoscopic access to and/or visualization of a targeted internal operating field. There is no functional obturator preassembled to any cannula unit to aid insertion of the cannula unit into tissue. Each

cannula unit is supplied obturator-free. Each cannula unit is sized and configured to accommodate passage of a conventional trocar assembly.

[0017] For installing every cannula unit, the system and method include a single trocar assembly sized to pass through the cannula unit. The trocar assembly includes a pre-assembled single endoscopic cannula and a single dedicated functional obturator. The system and method make possible the repeated use of the single trocar assembly to aid insertion of multiple cannula units into tissue, establishing an array of multiple endoscopic access sites using a single trocar assembly as the only obturator. The system and method make possible significantly less environmental damage due to medical waste, as well as contribute to lowered health care costs.

[0018] Another aspect of the invention provides another simplified system and method for performing an endoscopic surgical procedure. The system and method are directed head-on to the solution of the problem of excess medical waste and unnecessary medical equipment costs associated with conventional endoscopic procedures. The system and method provide single use cannula units sized and configured to accommodate a conventional endoscopic instrument (e.g., 5 mm, or 10 mm, or 12 mm); however, none of the cannula units is mated or made available with its own obturator. The cannula units are each provided obturator-free and are installed in multiple arrays using but a single conventional functional obturator. The single functional obturator is itself supplied as part of a preassembled conventional LT of the same size, which can be provided as a kit along with one or more cannula units or separately from another source. The system and method make it possible to establish an array of multiple endoscopic access sites (comprising the cannula units and the cannula of the LT) using only a single functional obturator.

[0019] The systems and methods described provide, for the first time, a plurality of stand-alone, single use endoscopic cannula units, free of their own dedicated obturators, that can be installed either by use of a preassembled single trocar preassembly or by use of a single functional obturator during a given surgical procedure. The result is, for a given endoscopic procedure entailing the installation of several cannula access units, the need for only one functional obturator. Cost savings and less environmental damage result.

#### BRIEF DESCRIPTION OF THE DRAWINGS

[0020] FIGS. 1A to 1E are views of a conventional laparoscopic trocar and its method of use.

[0021] FIG. 2 is a view of a simplified system for performing an endoscopic surgical procedure that makes possible the installation of multiple non-conventional cannula units using a single conventional functional obturator.

[0022] FIG. 3A is an exploded view of components of the system shown in FIG. 2, comprising a cannula unit, an endoscopic cannula, and a dedicated functional obturator for the endoscopic cannula.

[0023] FIG. 3B is a partially assembled view of components of the system shown in FIG. 2, comprising the cannula unit, and a trocar assembly comprising the dedicated functional obturator inserted into the endoscopic cannula.

[0024] FIG. 3C is a fully assembled view of components of the system shown in FIG. 2, comprising the trocar assembly inserted into the cannula unit, forming a concentric access assembly.

[0025] FIGS. 4A and 4B are fully and partially exploded views of the gas seal assembly that forms a part of the cannula unit that is a component of the system shown in FIG. 2.

[0026] FIG. 4C is an elevation, fully assembled view of the cannula unit that is a component of the system shown in FIG. 2.

[0027] FIG. 5A is an enlarged section view of the gas seal assembly shown in FIGS. 4A and 4B, before insertion of an endoscopic instrument.

[0028] FIG. 5B is an enlarged section view of the gas seal assembly shown in FIGS. 4A and 4B, during insertion of an endoscopic instrument.

[0029] FIG. 5C is an enlarged section view of the gas seal assembly shown in FIGS. 4A and 4B, during withdrawal of an endoscopic instrument.

[0030] FIG. 5D is an enlarged section view of the first functional seal of the gas seal assembly shown in FIGS. 5A to 5C.

[0031] FIGS. 6A to 6I are a sequence of views showing a representative method of using the simplified system shown in FIG. 2.

[0032] FIG. 7 is a view of another simplified system for performing an endoscopic surgical procedure that makes possible the installation of multiple non-conventional cannula units using a single conventional functional obturator.

[0033] FIGS. 8A to 8H are a sequence of views showing a representative method of using the simplified system shown in FIG. 7.

[0034] FIG. 9 is a view of a view optimizing assembly for use with a state of the art laparoscope.

[0035] FIGS. 10A to 10C are a sequence of views showing a representative method of using the view optimizing assembly shown in FIG. 9 in association with the system shown in FIG. 2.

[0036] FIGS. 11A to 11C are enlarged views showing the details of the deflector assembly that forms a part of the view optimizing assembly shown in FIG. 9 that prevents fogging of the laparoscopic lens and deflects smoke and debris away from the lens during surgery.

[0037] FIGS. 12A and 12B are alternative views of a continuous flow tubing assembly that can be used in conjunction with the view optimizing assembly shown in FIG. 9.

#### DESCRIPTION OF THE PREFERRED EMBODIMENTS

[0038] Although the disclosure hereof is detailed and exact to enable those skilled in the art to practice the invention, the physical embodiments herein disclosed merely exemplify the invention, which may be embodied in other specific structure. While the preferred embodiment has been described, the details may be changed without departing from the invention, which is defined by the claims.

##### I. Multiple Endoscopic Access Systems and Methods Employing a Single Obturator

###### A. First Representative Embodiment

###### An Overview

[0039] FIG. 2 shows a simplified system 20 for performing an endoscopic surgical procedure. The system 20 is particularly well suited for use in a situation in which it is desirable to make use of a specialized endoscopic instrument, which provides one or more desirable functional benefits, but which

possesses a marginally increased exterior diameter that falls between the cannula sizes used by conventional LT's. For example, and as will be described by example in greater detail later, a given specialized endoscopic instrument having desirable features may require a 7-8 mm access site, which is too large to fit a conventional 5 mm LT, and small enough to not require a conventional 10 mm LT. In the hierarchy of cannula sizes for conventional LT's, cannulas suitable for a 7-8 mm instrument are available but are not uniformly stocked by hospitals, and when they are, they require their own dedicated obturators. The system 20 solves this problem by providing a non-conventional cannula unit 22 to accommodate a marginally larger endoscopic instrument (e.g., 7 to 8 mm), which can be installed using a single smaller diameter conventional LT (e.g., 5 mm), which is then used at another puncture site once the marginally larger cannula unit 22 has been set and the smaller LT withdrawn. The system's solution also makes possible the installation of multiple non-conventional cannula units 22 using a single conventional functional obturator. The result is significantly less medical waste, as well as lowered health care equipment costs.

**[0040]** More particularly, the system 20 includes a plurality of individual endoscopic cannula units 22 as will be described in greater detail later. The cannula units 22 provide an array of access sites for minimally invasive endoscopic access to and/or visualization of a targeted internal operating field. As shown in FIG. 2, there is no functional obturator pre-assembled to any cannula unit 22 to aid insertion of the cannula unit into tissue. Each cannula unit 22 is supplied obturator-free.

**[0041]** The system 20 also include a single trocar assembly 24. The trocar assembly 24 includes a single endoscopic cannula 26, which provides one additional site for endoscopic access to the operating field. The trocar assembly 24 also includes, for the cannula 26, a single dedicated functional obturator 28 to aid insertion of the trocar assembly 24 as a unit into tissue. The single dedicated functional obturator 28 of the trocar assembly is the only functional obturator the system 20 provides.

**[0042]** As will be described in greater detail later, each endoscopic cannula unit 22 of the system is sized and configured to be marginally larger in internal diameter than the largest external diameter of the single trocar assembly 24. This makes possible the repeated use of the single trocar assembly 24 to aid insertion of all cannula units 22 into tissue. The system 20 makes possible a method for establishing an array of multiple endoscopic access sites using a single trocar assembly 24 as the only obturator, resulting in significantly less environmental damage due to medical waste, as well as contributing to lowered health care costs.

**[0043]** 1. The Single Trocar Assembly

**[0044]** The single endoscopic trocar assembly 24 comprises a single endoscopic cannula 26 and a single, dedicated functional obturator 28, as shown in FIG. 3A, which are provided preassembled with the system 20, as FIGS. 2 and 3B show. Alternatively, a trocar assembly 24 can be provided separately and later used in association with one or more cannula units 22 (also separately supplied).

**[0045]** The endoscopic cannula 26 can be conventionally sized to accommodate, upon removal of the dedicated obturator 28, conventional endoscopic tools and the attachment of an insufflations line. Both components of the single endo-

scopic trocar assembly 24 are intended to be used once during a given procedure, and thereafter discarded or, if desired, reprocessed.

**[0046]** By "functional obturator," it is meant that obturator 28 includes a pointed or conical, tissue piercing tip 30, which is sized and configured, during passage in tissue, to incise or separate tissue. By "trocar assembly" with a "dedicated functional obturator," it is meant that the single functional obturator 28 is supplied pre-assembled with the single endoscopic cannula 26, such that the pointed or conical, tissue piercing tip 30 of the obturator 28 is oriented to aid the insertion of the endoscopic trocar assembly 24 as a unit into tissue.

**[0047]** In the illustrated embodiment, the single functional obturator 28 is pre-assembled in a sliding fit within a lumen of the single endoscopic cannula 26 (see FIG. 3B), to form the trocar assembly 24. When fitted within the lumen, the pointed or conical, tissue piercing tip 30 of the obturator 28 protrudes from an open distal end of the lumen to incise or separate tissue in advance of the distal end of the endoscopic cannula 26. As shown in FIGS. 3A and 3B, the distal end of the endoscopic cannula 26 can itself be funnel shaped to aid the insertion of the trocar preassembly as a unit into tissue.

**[0048]** The trocar assembly 24 can be a conventional, off-the-shelf LT, having a cannula diameter that is common in the practice of endoscopic procedures, e.g., 5 mm; 10 mm; or 12 mm.

**[0049]** 2. The Cannula Units

**[0050]** The endoscopic cannula units 22 are each individually sized and configured to provide a site of minimally invasive, endoscopic access to a targeted internal operating field, e.g., within an abdomen.

**[0051]** By "cannula unit," it is meant that a given cannula unit 22 is not supplied with its own dedicated functional obturator. That is, the system provides the ability to create multiple endoscopic access sites (i.e., using the multiple cannula units 22 and the single trocar assembly 24), but provides for use of only a single functional obturator. The single functional obturator for the multiple cannula units 22 is the endoscopic trocar assembly 24 itself.

**[0052]** As FIG. 3B shows, each endoscopic cannula unit 22 comprises a tubular sleeve that defines an interior lumen 32. A given cannula unit 22 can be formed by molding or machining from a biocompatible plastic or metal material. When fabricated from plastic material, the cannula unit can be transparent or opaque. The exterior of a cannula unit can include a ribbed outer profile 34 to take purchase in tissue, and can further include loops (not shown) for the passage of sutures to secure the cannula unit 22 to tissue during use. The cannula units 22 are intended to be disposable, low cost items, to be used once during a given procedure, and thereafter discarded.

**[0053]** As FIG. 3C shows, the interior diameter of the lumen 32 of the cannula unit 22 is purposefully sized and configured to be slightly larger than the exterior diameter of the endoscopic cannula 26 of trocar assembly 24, to smoothly and tightly accommodate passage of the entire trocar assembly 24 through the lumen 32 of the cannula unit 22. For example, if the trocar assembly 24 has a 5 mm outside diameter, the interior diameter of the cannula unit 22 can be marginally larger, e.g., 7.5 to 8 mm. The interior lumen 32 of each cannula unit 22 has a maximum axial length that is equal to or less than the maximum axial length of the endoscopic cannula 26 of the trocar assembly 24.

**[0054]** Thus, each endoscopic cannula unit 22 can be individually fitted for insertion, one at a time, concentrically over

the entire pre-assembled endoscopic trocar assembly 24, with the dedicated functional obturator 28 of the trocar assembly 24 protruding beyond both the endoscopic cannula 26 of the trocar assembly 24 and the separate cannula unit 22. That is, a given cannula unit 22 can be fitted over the exterior cannula 26 of the trocar assembly 24, to which the dedicated functional obturator 28 is pre-assembled. The result is that the single trocar assembly 24 can itself be repeatedly reused during the span of a given procedure as the only functional obturator to install multiple cannula units 22.

[0055] In a representative embodiment (see FIGS. 3B and 3C), the cannula unit 22 includes a distal working region having an interior lumen 32 (the working lumen) sized and configured to provide an access site through which the single trocar assembly 24 can pass. For example, for use in association with a 5 mm (internal diameter, but with a larger external diameter) trocar assembly 24, the interior diameter of the working lumen 32 of the cannula unit can be about 7.5 to 8 mm.

[0056] In a representative embodiment (see FIGS. 4A, 4B, and 4C), the cannula unit 22 further includes a proximal region that includes a gas seal assembly 36. The gas seal assembly 36 serves to prevent loss of insufflation gas from the operating cavity through the working lumen 32 of the cannula unit 22, either when no instrument occupies the working lumen 32 or when an instrument occupies the working lumen 32.

[0057] The gas seal assembly 36 can be variously sized and configured.

[0058] In a representative embodiment (see FIG. 4C), a cap 38 spans the proximal region of the cannula unit 22. As shown in FIG. 4A, the cap 38 includes a working passage 40, which, when fitted to the proximal region, is axially aligned with the working lumen 32 of the cannula unit 22. As best shown in FIG. 4A, the working passage 40 includes an entry orifice 42 on the proximal end of the cap 38 and an exit orifice 44 within the cap 38. As FIG. 5B shows, an instrument I can be inserted into the entry orifice 42 and through the working passage 40 to the exit orifice 44, and thus into and through the working lumen 32 of the cannula unit 22.

[0059] In this arrangement, the gas seal assembly 36 is housed entirely within the cap 38 in-line with the working passage 40. In a representative embodiment, the gas seal assembly 36 desirably includes two cooperating functional seals 46 and 48. A first functional seal 46 is positioned near the exit orifice 44. A second functional seal 48 is positioned near the entry orifice 42.

[0060] The first functional seal 46 is sized and configured to normally prevent gas loss when an instrument I is not inserted through the working passage 40, i.e., when the working lumen 32 of the cannula unit 22 is unoccupied (see FIG. 5A). The first functional seal 46 is also sized and configured to yield during the insertion of an instrument I through the working passage 40 into the working lumen 32, and desirably without obstructing the insertion (see FIG. 5B).

[0061] The second functional seal 48 is sized and configured to prevent gas loss as the first functional seal 48 yields to the insertion of an instrument I through the working passage 40 into the working lumen 32 of the cannula unit 22 (as shown in FIG. 5B). However, upon removal of the instrument I from the working passage 40 (see FIG. 5C), the first functional seal 46 is sized and configured to quickly return from its yielded condition to its normal condition, again preventing gas loss.

[0062] As a result, there is no gas loss through the working lumen 32 of the cannula unit 22 as the cannula unit 22 serves its purpose of providing minimally invasive access to the insufflated operating cavity.

[0063] The size and configuration of the cooperating first and second functional seals 46 and 48 can vary.

[0064] In a representative embodiment, the first functional seal 46 comprises a flap valve component located adjacent the exit orifice 44 of the working passage 40 (see FIG. 4C). The flap valve component 46 is movable, in the absence of an instrument I occupying the exit orifice (as FIG. 5A shows), to a flap closed condition in response to exposure to typical insufflation pressure (e.g., 15 mmHg) in the working lumen 32. In the flap closed condition, the flap valve component 46 closes and seals the exit orifice 44, as FIG. 5A shows. In this way, the flap valve component 46 prevents gas loss when an instrument I is not inserted through the exit orifice 44.

[0065] As FIG. 5B shows, the flap valve component 46 is pushed away from the flap closed condition in response to the insertion of an instrument I through the exit orifice 44 and thus through the flap valve component 46 itself. The flap valve component 46 is sized and configured to flexibly yield to the passage of the instrument I, without damage to the flap valve component 46 and preferably without obstructing the instrument's passage, which is what FIG. 5B shows.

[0066] As shown in FIG. 5C, upon removal of the instrument I from the exit orifice 44 (and thus freeing the flap valve component 46), the flap valve component 46 returns to the flap closed condition in response to exposure to insufflation pressure in the now-unoccupied working lumen 32 of the cannula unit 22.

[0067] The diameter of flap valve component 46 is selectively sized and configured relative to the diameter of the exit orifice 44 to effectively cover and seal the exit orifice 44 in response to a typical range of insufflation pressures. In a representative embodiment, for an exit orifice 44 having a diameter of 0.4", a flap valve component 46 having a diameter 0.5" will affect a desired seal.

[0068] Further, the proximal region of the lumen of the cannula unit is desirably sized and configured to form a pressure directing chamber 50 immediately distal to the flap valve component 46. The pressure directing channel 50 accommodates and complements the fit and function of the flap valve component 46, as its condition is affected by insufflation pressures and the passage of instruments.

[0069] In a representative embodiment (see FIGS. 5A and 5D), pressure directing chamber 50 enlarges the radial dimensions of the working channel 32 in the vicinity of the flap valve component 46, and is further elongated axially to accommodate, without interference and damage, the movement of the flap valve component 46 between its closed and yield conditions. The radial enlarged chamber 50 desirably terminates near the exit orifice 44 to define a sharp lip edge 52 bounding the flap valve component 46 in generally the same plane as the flap valve component 46 (see FIG. 5D). As FIG. 5A shows, the lip edge 52 directs gas in the chamber 50 uniformly upward against the flap valve component 46, and not around the flap valve component 46, thereby minimizing vibration of the flap valve component 46 when closed or closing. The uniform pressure applied upwardly by the chamber 50 maintains a closed and sealed exit orifice 44 in the absence of an instrument I. The upward flow of gas through the chamber 50 also aids the rapid return of the flap valve

component 46 to the closed condition upon removal of an instrument I from the exit orifice, as FIG. 5C shows.

[0070] The material type, thickness, and durometer of the flap valve component 46 can be further selected to optimize the fit and function of the flap valve component 46 in the presence of a range of typical insufflation pressures. In a representative embodiment, the flap valve component 46 is made, e.g., of a polyurethane material having a durometer of from 85 to 90 shore A. In this embodiment, the flap valve component 46 relies upon a combination of the focused application of insufflation pressure and the material properties of the flap valve component 46 itself to seal the exit orifice 44.

[0071] In this arrangement, the second functional seal 48 comprises an elastomeric septum located adjacent the entrance orifice 42 of the working passage 40. The elastomeric septum 48 is sized and configured to create a sliding seal along the instrument I as it passes through the entrance orifice.

[0072] In a representative embodiment (see FIGS. 4A and 4B), the gas seal assembly 36 comprises a low profile unitary body 54, made possible by the unique first (gas) functional seal 46 and second (instrument) functional seal 48 combination, which is unlike the duckbill and cone seals used in most commercially available trocars. The unitary body 54 is formed (e.g., by molding or machining plastic or metal materials) with the working passage 40, the entrance orifice 42, and the exit orifice 44 integrally formed. The first and second functional seals 46 and 48 are attached to the unitary body 54. The gas seal assembly 36 can then be inserted as a unit into the cap 38. As a result, the cap 38 itself can be low-profile (e.g., in a representative embodiment, an axial height of 0.4 in).

[0073] 3. Representative Method of Use

[0074] The unique functional features of each cannula unit as described make possible a unique method of establishing an array of multiple endoscopic access sites using only a single functional obturator. FIGS. 6A to 6I show a representative method that makes use of these features.

[0075] The method includes (see FIG. 6A) (i) providing a single endoscopic trocar assembly 24 comprising a single endoscopic cannula 26 and a single, dedicated functional obturator 28, as described above.

[0076] The method further includes (see FIG. 6B) (ii) providing one or more endoscopic cannula units 22, as described above, free of (i.e., without) its own dedicated functional obturator. Each cannula unit 22 has a minimum interior diameter sized and configured to smoothly and tightly accommodate passage of the endoscopic cannula 26, which forms the exterior of the single trocar assembly 24. The cannula unit 22 has a maximum axial length that is equal to or less than the maximum axial length of the endoscopic cannula 26 of the trocar assembly 24.

[0077] The method further includes (see FIG. 6C) (iii) selecting a single one of the cannula units 22 for inserting into tissue to provide a site of minimally invasive, endoscopic access to a targeted internal operating field.

[0078] As FIG. 6D further shows, the method further includes (iv) fitting the selected cannula unit 22 over the entire single trocar assembly 24.

[0079] By fitting the cannula unit 22 over the entire trocar assembly 24, a concentric access assembly 56 for the cannula unit 22 is created. The concentric access assembly 56 comprises, from interior to exterior, the dedicated functional obturator 28 of the trocar assembly 24, the endoscopic cannula 26 of the trocar assembly 24, and the selected cannula unit 22.

The concentric access assembly 56 includes, protruding beyond the distal end of the cannula unit 22, the penetrating tip 30 of a functional obturator 28.

[0080] The method further includes (see FIG. 6D) (v) manipulating the concentric access assembly 56 as an integrated unit into tissue, allowing the protruding, penetrating tip 30 of the functional obturator to incise or separate tissue to achieve body penetration. At this stage in the procedure, an insufflation line can be connected to a stopcock 18 conventionally provided on the trocar assembly 24, to pressurize the operating cavity.

[0081] The method further includes, after body penetration and insufflation have been made (see FIG. 6E), (vi) withdrawing the trocar assembly 24 from the cannula unit 22, leaving the cannula unit 22 in place providing access to the operating cavity. The gas seal assembly 36 in the cannula unit 22, as above described, prevents loss of insufflation pressure as the method progresses.

[0082] The method optionally includes, after (vi) (see FIGS. 6F and 6G) the repeated reuse of the single trocar assembly 24 to install any desired number of selected cannula units 22 to provide any desired number of abdominal penetrations. For each abdominal penetration (see FIG. 6F), a given cannula unit 22 is fitted concentrically over the entire trocar assembly 24 to form a concentric access assembly 56 that includes the additionally selected cannula unit 22. The concentric access assembly 56 is again manipulated as a single unit, allowing the protruding, penetrating tip 30 of the functional obturator 28 to again incise or separate tissue to again achieve body penetration. Once penetration has been made (see FIG. 6G), the trocar assembly 24 is withdrawn from the cannula unit 22. Another selected cannula unit 22 remains to provide additional access to the operating cavity.

[0083] The method further includes, after insertion of all desired cannula units 22, the use of the trocar assembly 24 by itself in a traditional manner for form yet another access site. As shown in FIG. 6H, the method includes (vii) manipulating the trocar assembly 24 as an integrated unit into tissue, this time without a cannula unit 22, allowing the protruding, penetrating tip 30 of the functional dedicated obturator 28 to incise or separate tissue to achieve body penetration for the cannula 26. The method further includes, after body penetration has been made (see FIG. 6I), (viii) withdrawing the dedicated functional obturator 28 of the trocar assembly 24 from the endoscopic cannula 26 of the trocar assembly 24, leaving the endoscopic cannula 26 of the trocar assembly 24 in place providing additional access to the operating cavity and/or for the couples of insufflations pressure (to the stopcock 18).

[0084] Following (viii) (as FIG. 6I shows), the dedicated functional obturator 28 of the trocar assembly 24 can be discarded as medical waste. A comparison of FIG. 1E (prior art) to FIG. 6I graphically demonstrates the significant reduction in environmental damage due to medical waste, as well as the contribution to lowered health care costs, that the technical features of the system and method provide.

[0085] The system 20 and method make possible the use of a single functional obturator (i.e., the dedicated obturator 28 of the trocar assembly 24) for multiple endoscopic entries. The presence of the cannula unit 22 does not disturb either visualization during entry or significantly enlarge the penetration site.

[0086] To the extent that several cannula units 22 are installed during a given procedure, only one trocar assembly

**24** (comprising only one dedicated functional obturator **28**) need be used for the multiple entries. Thus (as FIG. 6I demonstrates), at the end of the procedure, there remains, as medical waste, only a single functional obturator (i.e., the dedicated obturator **28** of the trocar assembly **24**), which is significantly less than the number of cannulas and abdominal penetrations deployed during the procedure. Cost savings and less environmental damage result.

## B. Second Representative Embodiment

### An Overview

**[0087]** FIG. 7 shows another representative embodiment of simplified system **58** for performing an endoscopic surgical procedure. The system **58** solves the problem of excess medical waste and unnecessary medical equipment costs associated with conventional endoscopic procedures. The system **58** solves this problem by providing single use cannula units **60** sized and configured to accommodate a conventional endoscopic instrument (e.g., 5 mm, or 10 mm, or 12 mm), which can be installed in arrays of multiple cannula units **60** using but a single conventional functional obturator **62** that is supplied in a preassembled conventional LT **64** (as a kit with the cannula units **22**, or acquired separately and later used in association with the cannula units **22**) having an endoscopic cannula **66** with the same interior diameter as the cannula unit **60**.

#### **[0088]** 1. The Cannula Units

**[0089]** The system **58** (see FIG. 7) includes a plurality of individual endoscopic cannula units **60** like that previously described, but possessing a diameter suited for passing a conventional endoscopic instrument (e.g., 5 mm, or 10 mm, or 12 mm). The cannula units **60** provide an array of access sites for minimally invasive endoscopic access to and/or visualization of a targeted internal operating field. As shown in FIG. 7, there is no functional obturator preassembled to any cannula unit **60** to aid insertion of the cannula unit **60** into tissue. Each cannula unit **60** is supplied obturator-free.

**[0090]** Except for its interior diameter, the cannula units **60** shown in FIG. 7 desirably possess the same technical features described for the of the cannula units **22** shown in FIG. 2 (and as further shown in FIGS. 4A/B/C and 5A/B/C/D).

#### **[0091]** 2. The Trocar Assembly

**[0092]** The system **58** may include a single trocar assembly **64** (see FIG. 7). Alternatively, as above described, the cannula units **60** may be provided separately (either alone or as a plurality), and the obturator **62** used for their passage obtained from a conventional LT obtained from another source. Like the cannula unit **60**, the trocar assembly **64** possesses a diameter accommodating a conventional endoscopic instrument (e.g., 5 mm, or 10 mm, or 12 mm), and can itself comprise a convention LT. As earlier described (and as shown in FIG. 3A), the trocar assembly **64** includes a single endoscopic cannula **66**, which provides one additional site for endoscopic access to the operating field. The trocar assembly **64** also includes, for the cannula, a single dedicated functional obturator **62** to aid insertion of the trocar assembly **64** as a unit into tissue. The single dedicated functional obturator **62** of the trocar assembly **64** is the only functional obturator the system **58** provides.

#### **[0093]** 3. Representative Method of Use

**[0094]** The unique functional features of each cannula unit as described make possible a unique method of establishing an array of multiple endoscopic access sites using only a

single functional obturator. FIGS. 8A to 8I show a representative method that makes use of these features.

**[0095]** The method includes (see FIG. 8A) (i) providing a single endoscopic trocar assembly **64** comprising a single endoscopic cannula **66** and a single, dedicated functional obturator **62**, as described above.

**[0096]** The method further includes (see FIG. 8B) (ii) providing one or more endoscopic cannula units **60**, as described above, free of (i.e., without) its own dedicated functional obturator. Each cannula unit **60** has an interior diameter sized and configured to smoothly and tightly accommodate passage of the obturator **62** when removed from the trocar assembly **64** (which can comprise a conventional LT), after that trocar assembly **64** (or conventional LT) has been passed through the abdominal wall and the obturator **62** removed so it can be reused. The cannula unit **60** has a maximum axial length that is equal to or less than the maximum axial length of the endoscopic cannula **66** of the trocar assembly **64** (or conventional LT).

**[0097]** The method further includes, prior to insertion of any of the cannula units **60** (see FIG. 8C), (iii) the use of the trocar assembly **64** (or conventional LT) by itself in a traditional manner for form an access site. As shown in FIG. 8C, the method includes manipulating the trocar assembly **64** (or conventional LT) as an integrated unit into tissue, allowing the protruding, penetrating tip **68** of the functional dedicated obturator **62** to incise or separate tissue to achieve body penetration for the cannula **66**. The method further includes, after body penetration has been made (see FIG. 8D), (iv) withdrawing the dedicated functional obturator **62** of the trocar assembly **64** (or conventional LT) from the endoscopic cannula **66** of the trocar assembly **64** (or conventional LT), leaving the endoscopic cannula **66** of the trocar assembly **64** (or conventional LT) in place providing access to the operating cavity. At this stage in the procedure, an insufflation line can be connected to a stopcock **18** conventionally provided on the trocar assembly **64**, to pressurize the operating cavity.

**[0098]** The method further includes, after insertion of the cannula **66** of the trocar assembly **64** (or conventional LT) (see FIG. 8E), selecting a single one of the cannula units **60** for inserting into tissue to provide a site of minimally invasive, endoscopic access to a targeted internal operating field, and fitting the selected cannula unit **66** over the functional obturator **62** withdrawn from the trocar assembly **64** (or conventional LT).

**[0099]** As FIG. 8E shows, by fitting the cannula unit **60** over the functional obturator **62** withdrawn from the trocar assembly **64** (or conventional LT), a concentric access assembly **70** for the cannula unit **60** is created. The concentric access assembly **70** comprises, from interior to exterior, the functional obturator **62** withdrawn from the trocar assembly **64** (or conventional LT) and the selected cannula unit **60**. The concentric access assembly **70** includes, protruding beyond the distal end of the cannula unit **60**, the penetrating tip **68** of the functional obturator **62**.

**[0100]** As FIG. 8E shows, the method further includes (v) manipulating the concentric access assembly **70** as an integrated unit into tissue, allowing the protruding, penetrating tip **68** of the functional obturator **62** to incise or separate tissue to achieve body penetration.

**[0101]** The method further includes, after body penetration of the cannula unit **60** has been made (see FIG. 8F), (vi) withdrawing the functional obturator **62** from the cannula unit **60**, leaving the cannula unit **60** in place providing access

to the operating cavity. A gas seal assembly 36 in the cannula unit 60, as above described, prevents loss of insufflation pressure as the method progresses.

[0102] The method optionally includes, after (vi) (see FIGS. 8H and 8I) the repeated reuse of the functional obturator 62 withdrawn from the trocar assembly 64 (or conventional LT) to install any desired number of selected cannula units 60 to provide any desired number of abdominal penetrations. For each abdominal penetration, a given cannula unit 60 is fitted concentrically over the functional obturator 62 withdrawn from the trocar assembly 64 (or conventional LT), to form a concentric access assembly 70 that includes the additionally selected cannula unit 60. The concentric access assembly 70 is again manipulated as a single unit, allowing the protruding, penetrating tip 68 of the functional obturator 62 to again incise or separate tissue and again achieve body penetration. Once penetration has been made (see FIG. 8I), the functional obturator 62 is withdrawn from the cannula unit 60. Another selected cannula unit 60 remains to provide additional access to the operating cavity.

[0103] Following (vi) (as FIG. 8I shows), the dedicated functional obturator 62 of the trocar assembly 64 (or conventional LT) can be discarded as medical waste. A comparison of FIG. 1E (prior art) to FIG. 8I graphically demonstrates the significant reduction in environmental damage due to medical waste, as well as the contribution to lowered health care costs, that the technical features of the system and method provide.

[0104] The system 58 and method make possible the use of a single functional obturator (i.e., the dedicated obturator 62 of the trocar assembly 64 or conventional LT) for multiple endoscopic entries. The presence of the cannula unit 60 does not disturb either visualization during entry or significant enlarge the penetration site.

[0105] To the extent that several cannula units 60 are installed during a given procedure, only one trocar assembly 64 or conventional LT (comprising only one dedicated functional obturator 62) need be used for the multiple entries. Thus (as FIG. 8I demonstrates), at the end of the procedure, there remains, as medical waste, only a single functional obturator 62 (i.e., the obturator of the trocar assembly 64 or conventional LT), which is significantly less than the number of cannulas and abdominal penetrations deployed during the procedure. Cost savings and less environmental damage result.

## II. Creating Endoscopic Access for a Specialized View Optimizing Assembly

### A. Overview

[0106] FIG. 9 shows an embodiment of a view optimizing assembly 110 for use in association with a state of the art laparoscope 112 (as shown in FIGS. 10A to 10C). The components of the view optimizing assembly 110 may be made from plastic materials (extruded and/or molded), but other suitable materials, such as metal or a composite material, or combinations thereof could be used.

[0107] As shown in FIG. 9, the view optimizing assembly 110 comprises a multi-lumen sheath assembly 114. The sheath assembly 114 is sized and configured to mount over the shaft of a conventional laparoscope 112, as FIGS. 10A and 10B show. The end of the sheath 114 is sized and configured to match the size and configuration of the end of the corresponding laparoscope 112, which in FIG. 10A is shown to be angled.

[0108] As FIG. 9 shows, the assembly 110 includes a tubing set 116 and a source of flushing liquid 172. In the illustrated embodiment, the source of flushing liquid 172 comprises a syringe 174, which contains the flushing liquid 172. The flushing liquid 172 can include a surface-active agent (surfactant) to aid removal of fatty debris. For example, the flushing liquid 172 can be a solution comprising (i) Docusate Sodium: 0.050-0.20% v/v; (ii) Phosphate Buffer: 0.2% v/v; and (iii) Water for Injection H<sub>2</sub>O: 99.600-99.75%. The flushing liquid 172 is packaged in a 10 ml or 20 ml syringe 174, sterilized, and delivered to the surgical suite in a double poly pouch, as FIG. 9 shows.

[0109] As FIG. 10A shows, in use, the tubing set 116 connects the sheath 114 to a carbon dioxide (CO<sub>2</sub>) insufflation circuit, as well as to the syringe 174 containing the flushing liquid 172. As FIG. 10A also shows, a manifold 118 on the proximal end of the sheath 114 includes a quick exchange coupling 120 that mates with a quick exchange coupler 122 on the tubing set 116, to quickly couple the tubing set 116 in fluid communication with the interior lumens of the sheath 114.

[0110] The sheath 114 includes at its distal end a deflector assembly 164 (see FIGS. 11A and 11B). The deflector assembly 164 projects a predetermined distance beyond the distal end of the sheath 114, and thus also a predetermined distance beyond the lens at the distal end of the laparoscope 112.

[0111] As FIG. 11B shows, the deflector assembly 164 is sized and configured to direct the CO<sub>2</sub> gas that is conveyed along the sheath 114 through lumens in a prescribed flow path and flow velocity across the laparoscopic lens. As FIG. 11C shows, a rolling vortex can be created that extends across and beyond the laparoscopic lens. The flow path and flow velocity of the CO<sub>2</sub> across the laparoscopic lens prevents fogging and also desirably serves to deflect smoke and surgical debris away from the laparoscopic lens during surgery, thereby maintaining clear visualization of the surgical site without removing the laparoscope from the abdominal cavity for the purpose of cleaning or de-fogging its lens.

[0112] The surgical team may also depress the plunger of the syringe plunger 174 to dispense aliquots of 1 ml-5 ml of the flushing liquid 172 through the deflector assembly 164 (which conveyed through other lumens in the sheath) to flush debris off the end of the lens that may eventually accumulate.

[0113] The operator can, if desired, prompt a burst of CO<sub>2</sub> gas from the insufflation circuit over the lens (by squeezing the pneumatic flush bulb 180 in the tubing set 116), to further remove debris and/or residual droplets of the flushing liquid from the lens. Visualization is restored rapidly and without removal of the laparoscope from the abdomen.

[0114] It is desirable to integrate the assembly 110 as much as possible with the existing suite of minimally invasive instrumentation, to not interfere with the surgical set-up, and to require minimal change in the process or practice of the surgical team.

[0115] As above explained, conventional laparoscopes, like other laparoscopic tools, typically come in three standard diameter sizes: 5 mm, 10 mm, and 12 mm. To meet the above-stated desirable objective, the sheath assembly 114 is desirably sized with an interior diameter to accommodate a selected one of these laparoscope diameters, as well as with an exterior diameter to accommodate passage through a conventional LT.

[0116] The sheath 114, when sized and configured to provide its desirable functional benefit for the smallest diameter

conventional laparoscope (5 mm), possesses a marginally increased exterior diameter that falls between the cannula sizes used by conventional LT's. For example, the sheath 114 with an interior diameter sized for a 5 mm laparoscope has an exterior diameter which is larger than 5 mm, e.g., 7.5 to 8 mm. Although having an interior lumen sized for a conventional 5 mm instrument, the resulting 7-8 mm outer diameter of the sheath 14 is too large to fit a conventional 5 mm LT, and small enough to not require a conventional 10 mm LT.

[0117] This problem is effectively overcome by use of the system 20 shown in FIG. 2. The system 20, as previously described, provides a non-conventional cannula unit 22 to accommodate the marginally larger endoscopic dimensions of the sheath 14 (e.g., 7 to 8 mm), but nevertheless accommodating installation using a single smallest conventional 5 mm LT (e.g., 5 mm) (as shown in FIGS. 6A to 6I). Concurrently, use of the system 20 shown in FIG. 2 leads to additional benefits, including significantly less medical waste, as well as lowered health care equipment costs.

[0118] FIG. 10A shows the set up of the view optimizing assembly 110 with the system 20 comprising multiple access sites established by practicing the method shown in FIGS. 6A to 6I.

[0119] The method makes use of a single 5 mm endoscopic trocar assembly 24 (see FIG. 6A) and one or more marginally enlarged endoscopic cannula units 22 (see FIG. 6B). Each cannula unit 22 has an interior diameter sized and configured to smoothly and tightly accommodate passage of the 5 mm endoscopic cannula 26, which forms the exterior of the single trocar assembly 24. As a consequence, the exterior diameter of each cannula unit 22 is marginally increased.

[0120] The method selects a single one of the cannula units for inserting into tissue. The method fits the selected cannula unit 22 over the entire single trocar assembly 24 (FIG. 6C) to form a concentric access assembly 56, and manipulates the concentric access assembly 56 as an integrated unit into tissue (FIG. 6D). At this stage in the procedure, an insufflation line can be connected to the stopcock 18 provided on the trocar assembly 24, to pressurize the operating cavity.

[0121] After body penetration and insufflation have been accomplished (see FIG. 6E), the trocar assembly 24 is withdrawn from the cannula unit 22, leaving the cannula unit 22 in place, providing access to the operating cavity. The gas seal assembly 36 in the cannula unit 22, as above described, prevents loss of insufflation pressure as the method progresses.

[0122] The method optionally includes (see FIGS. 6F and 6G) the repeated reuse of the single trocar assembly 24 to install any desired number of selected cannula units 22, thereby providing any desired number of abdominal penetrations. In the illustrated embodiment (shown in FIG. 10A), two cannula units 22 are installed. One of these cannula units 22 will ultimately accommodate passage of the sheath 114 (as shown in FIGS. 10B and 10C).

[0123] After insertion of all desired cannula units 22, the trocar assembly 24 is itself inserted in a traditional manner, to form yet another access site (FIGS. 6H and 6I). As shown in FIG. 10A, the dedicated functional obturator 28 of the trocar assembly 24 is withdrawn from the endoscopic cannula 26 of the trocar assembly 24, leaving the endoscopic cannula 26 of the trocar assembly 24 in place providing additional access to the operating cavity as well as a site to couple an insufflation pressure line (i.e., to stopcock 18). The entire system 20

shown in FIG. 10A has been installed using but one functional obturator, which can later be discarded as medical waste, or reprocessed (see FIG. 6I).

[0124] As FIG. 10A shows, the tubing set 116 of the assembly 10 couples the insufflation circuit to the stopcock 18 of the cannula 26. As FIGS. 10B and 10C show, the laparoscope 112 is inserted into the sheath 114, and the sheath 114 and laparoscope 112 are inserted as a unit through one of the installed cannula units 22.

[0125] The system 20 and method therefore make possible the use of a single functional obturator (i.e., the dedicated obturator 28 of the trocar assembly 24) for multiple endoscopic entries. The presence of the cannula unit 22 does not disturb either visualization during entry or significantly enlarge the penetration site. Only one trocar assembly 24 (comprising only one dedicated functional obturator 28) need be used for the multiple entries. Thus (as FIG. 6I demonstrates), at the end of the procedure, there remains, as medical waste, only a single functional obturator (i.e., the dedicated obturator 28 of the trocar assembly 24), which is significantly less than the number of cannulas and abdominal penetrations deployed during the procedure. Cost savings and less environmental damage result.

#### B. Continuous Flow Tubing (CFT)

[0126] A conventional insufflation circuit periodically cycles off, to stop the flow of CO<sub>2</sub> gas to measure the pressure in the peritoneum. As shown in FIGS. 12A and 12B, the tubing set 116 can include a continuous flow tubing assembly 72 (called in shorthand, continuous flow tubing, or CFT), to store pressurized CO<sub>2</sub> gas in a reservoir 74, so that when the insufflation circuit stops the flow of gas to measure the pressure in the peritoneum, the flow of gas to sheath 114 is not interrupted. The reservoir 74 serves as a gas capacitor to store CO<sub>2</sub> gas at a static pressure reached in the tubing set 116. The reservoir 74 (i.e., gas capacitor) discharges the stored CO<sub>2</sub> gas at a controlled rate to the sheath 114 when the flow of gas stops.

[0127] As shown in FIGS. 12A and 12B, CFT 72 utilizes a gas reservoir 74 with an elastic diaphragm that expands during filling and maintains a static pressure. The illustrative system shown in FIG. 12A comprises a parallel flow circuit with two flow paths. Path 1 allows for minimal flow reduction when the insufflation circuit is supplying gas and charging the capacitor. Path 2 is operative when the gas capacitor is discharging. A directional valve closes 76 off Path 2 when the insufflation circuit is supplying gas which charges the gas capacitor. The directional valve 76 closes off Path 1 when the insufflation circuit stops supplying gas to measure peritoneum pressure. The static pressure residing in the gas capacitor (i.e., reservoir 74) then discharges to the sheath 114, which maintains a supply of gas across the laparoscope lens. A one-way valve 78 before the gas reservoir allows the gas capacitor to fill when the insufflation circuit is supplying gas and it prevents the back flow of gas when the insufflation circuit is measuring pressure inside the peritoneal space.

[0128] The directional valve 76 includes an interior ball that shifts side to side to block the flow paths. The ball is shifted by the pressure differential found between Paths 1 and 2.

[0129] The gas capacitor comprises an elastomeric reservoir 74 that expands to store approximately 50 cc of gas under pressure. The reservoir stores gas at 22 mmHg-24 mmHg.

The diaphragm is made from a biocompatible elastomer like silicone. Durometer is less than 25 shore A.

**[0130]** The one-way valve **78** can comprise a high flow, low cracking pressure, ball check valve.

**[0131]** The connectors to the CFT **72** can comprise standard luer fittings.

**[0132]** The illustrative CFT **72** shown in FIG. **12B** comprises a series flow circuit, in which gas flow to the sheath **114** (downstream of the branch leading to the abdominal cavity) passes through a one-way backflow valve **78** and the reservoir **74** on the way to the sheath **14**. When the insufflators cycles off, the one-way valve **78** closes, and static pressure in the reservoir **74** continues to be discharged into the sheath **114**.

**[0133]** The concept of CFT **72** comprises the placement of an in-line reservoir (or air capacitor) in the circuit that supplies gas to the sheath **14**. The reservoir collects gas during operation of the source insufflator and discharges gas for a brief periods while operation of the insufflator is periodically interrupted. There has never been a reason to provide a reservoir in an insufflations line, because no one has provided medical device that uses insufflation gas for anything but inflating the abdominal cavity.

We claim:

1. A method for accessing a body cavity when performing endoscopic surgery on a patient comprising:
  - providing a trocar assembly comprising a single endoscopic cannula and a single dedicated obturator;
  - providing one or more cannula units;
  - selecting one of the cannula units and fitting the selected cannula unit over the trocar assembly;
  - inserting the selected cannula unit into the tissue of the patient to achieve body penetration into the body cavity of the patient;
  - performing insufflation within the body cavity; and
  - removing the trocar assembly from the inserted cannula unit while maintaining insufflation pressure in the body cavity.
2. The method of claim 1 further comprising:
  - selecting a second cannula and fitting the second cannula unit over the trocar assembly;
  - inserting the second cannula unit into the tissue of the patient at a second location to achieve body penetration into the body cavity of the patient
  - performing insufflation within the body cavity; and
  - removing the trocar assembly from the inserted cannula unit while maintaining insufflation pressure in the body cavity.
3. The method of claim 1 further comprising:
  - inserting the trocar assembly into another location in the body tissue.
4. The method of claim 3 further comprising:
  - removing the obturator from the trocar assembly.
5. The method of claim 4 wherein the step of inserting the trocar assembly comprises
  - inserting the trocar assembly into another location after the step of inserting the selected cannula unit into the tissue of the patient.

6. The method of claim 4 wherein the step of inserting the trocar assembly comprises

inserting the trocar assembly into another location prior to the step of inserting the selected cannula unit into the tissue of the patient.

7. A system for accessing an operating cavity when performing endoscopic surgery comprising:

at least one obturator-free cannula unit for being inserted into body tissue; and

a trocar assembly comprising:

a single dedicated functional obturator, said single dedicated functional obturator being independent of said at least one cannula unit; and

an endoscopic cannula.

8. The system of claim 7 further comprising

a plurality of obturator-free cannula units, wherein said trocar assembly is reused for insertion of each obturator-free cannula unit into body tissue.

9. The system of claim 7 wherein the trocar assembly is preassembled.

10. The system of claim 7 wherein at least one of the cannula units further comprises a proximal region comprising a gas seal assembly for the prevention of the loss of insufflation gas through the cannula unit from the operating cavity when the system is in use.

11. The system of claim 10 wherein the gas seal assembly comprises a first functional seal and a second functional seal.

12. An optimizing assembly for use with a laparoscope having a lens, the assembly being used for accessing an operating cavity when performing endoscopic surgery, the assembly comprising:

a multi-lumen sheath assembly sized and configured to mount over the shaft of the laparoscope;

a tubing set for connection to an external carbon dioxide (CO<sub>2</sub>) insufflation circuit, said tubing set providing continuous flow of CO<sub>2</sub> to the operating cavity during the endoscopic surgery.

13. The optimizing assembly according to claim 12 wherein the sheath assembly further comprises a quick exchange coupling that mates with a quick exchange coupler located on the tubing set.

14. The optimizing assembly of claim 12 further comprising a source of flushing liquid; and  
means for delivering the flushing liquid across the surface of the lens.

15. The optimizing assembly of claim 14 further comprising means for delivering a burst of CO<sub>2</sub> across the surface of the lens.

16. The assembly of claim 12 further comprising a CO<sub>2</sub> reservoir located in-line of the tubing set, said reservoir including means for maintaining static pressure in the assembly and providing the continuous flow of CO<sub>2</sub> to the operating cavity.

17. The assembly of claim 16 wherein the means for maintaining static pressure comprises an elastic diaphragm located in the reservoir.

\* \* \* \* \*

专利名称(译)	用于执行内窥镜外科手术的装置，系统和方法		
公开(公告)号	<a href="#">US20120310147A1</a>	公开(公告)日	2012-12-06
申请号	US13/311085	申请日	2011-12-05
[标]申请(专利权)人(译)	微创设备有限公司		
申请(专利权)人(译)	微创器械有限责任公司		
当前申请(专利权)人(译)	微创器械有限责任公司		
[标]发明人	POLL WAYNE L DRACH GREGORY		
发明人	POLL, WAYNE L. DRACH, GREGORY		
IPC分类号	A61M13/00 A61B17/34		
CPC分类号	A61B17/3417 A61B19/5212 A61B19/34 A61B19/026 A61B17/3474 A61B1/00163 A61B1/3132 A61B17/3421 A61B17/3439 A61B17/3478 A61B50/30 A61B90/361 A61B90/70 A61B2017/3441 A61B2050/3006 A61M13/00 A61M13/003		
优先权	61/419357 2010-12-03 US		
其他公开文献	US9522017		
外部链接	<a href="#">Espacenet</a> <a href="#">USPTO</a>		

摘要(译)

用于在执行内窥镜手术时进入手术腔的方法和系统，包括：该系统和方法包括至少一个无闭塞器套管单元和套管针组件。套管针组件包括独立于套管单元和内窥镜套管的单个专用功能性闭塞器。本发明还提供了一种用于在腹腔镜手术期间提供连续二氧化碳流动的系统和方法。

