



US 20110066182A1

(19) **United States**

(12) **Patent Application Publication**  
**Falus**

(10) **Pub. No.: US 2011/0066182 A1**

(43) **Pub. Date: Mar. 17, 2011**

(54) **TISSUE SEALANT FOR USE IN NON  
COMPRESSIBLE HEMORRHAGE**

*A61P 43/00* (2006.01)

*A61B 17/03* (2006.01)

(52) **U.S. Cl. .... 606/214; 424/486; 424/94.5**

(75) Inventor: **George Falus, New York, NY (US)**

(57) **ABSTRACT**

(73) Assignee: **BIOMEDICA MANAGEMENT  
CORP, New York, NY (US)**

ClotFoam is a surgical sealant and hemostatic agent designed to be used in cases of non-compressible hemorrhage. It can be applied in the operating room through laparoscopic ports, or directly over lacerated tissue in laparotomy procedures or outside the operating room through a mixing needle and/or a spray injection method following abdominal, chest, extremities or other intracavitary severe trauma to promote hemostasis. Its crosslinking technology generates an adhesive three-dimensional polymeric network or scaffold that carries a fibrin sealant required for hemostasis. When mixed, Clotfoam produces a foam that spreads throughout a body cavity reaching the lacerated tissue to seal tissue and promote the coagulation cascade.

(21) Appl. No.: **12/750,316**

(22) Filed: **Mar. 30, 2010**

**Related U.S. Application Data**

(63) Continuation-in-part of application No. 12/419,734, filed on Apr. 7, 2009.

**Publication Classification**

(51) **Int. Cl.**

*A61K 9/00* (2006.01)

*A61K 38/45* (2006.01)

*A61P 17/02* (2006.01)

The viscoelastic attachment properties of the foam as well as the rapid formation of a fibrin clot that ensure that the sealant remains at the site of application without being washed away by blood or displaced by movement of the target tissue .

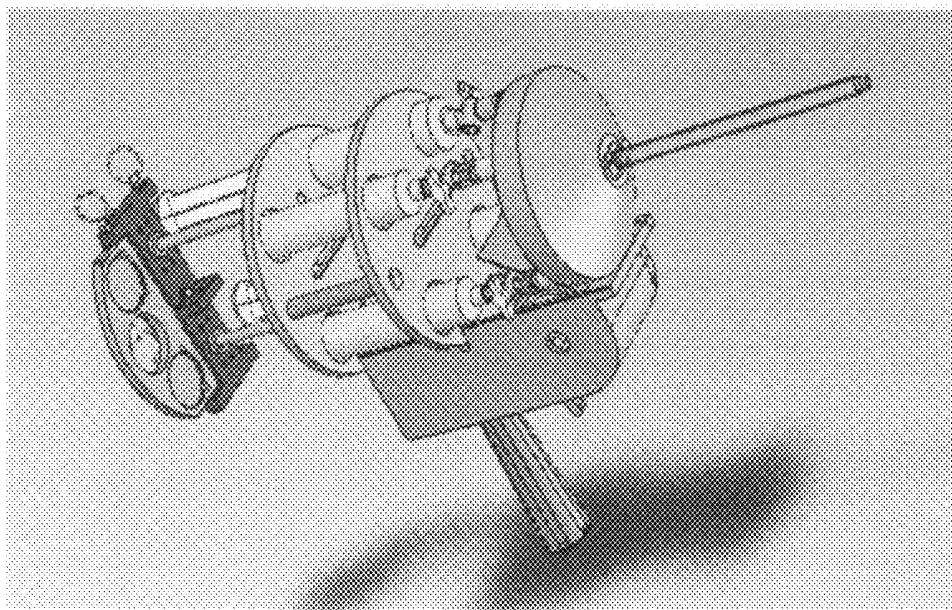

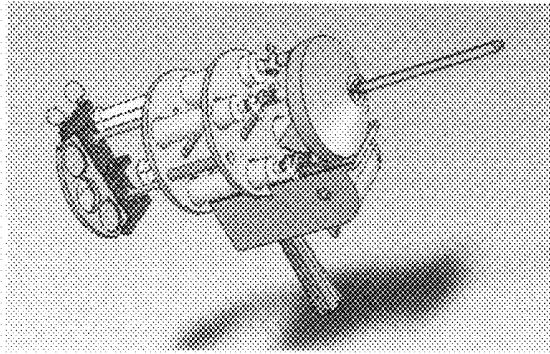

Fig. 1.

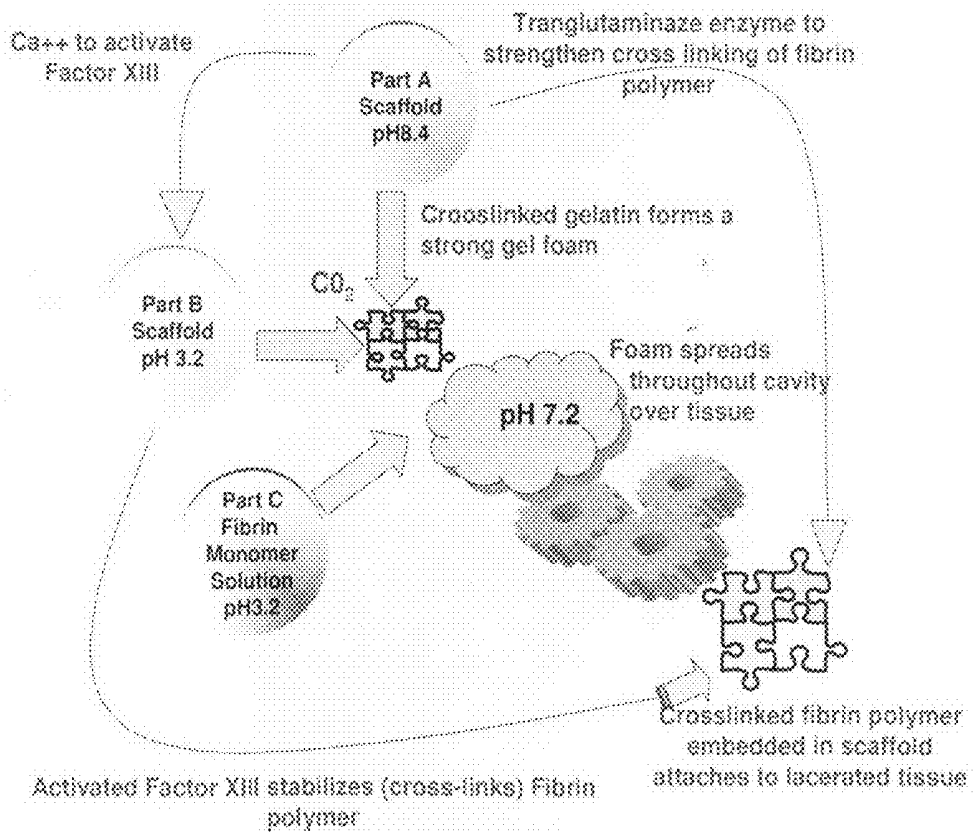

Fig. 2

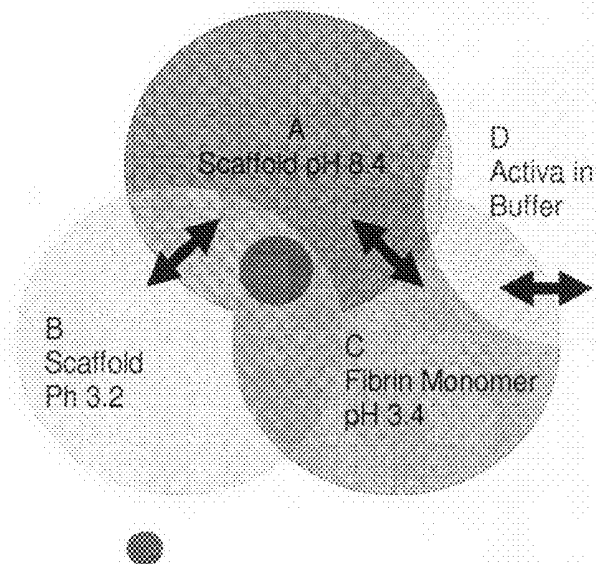

Fig. 3

Foam + Fibrin Polymer

**Intratissular Adherence**

p=0.001

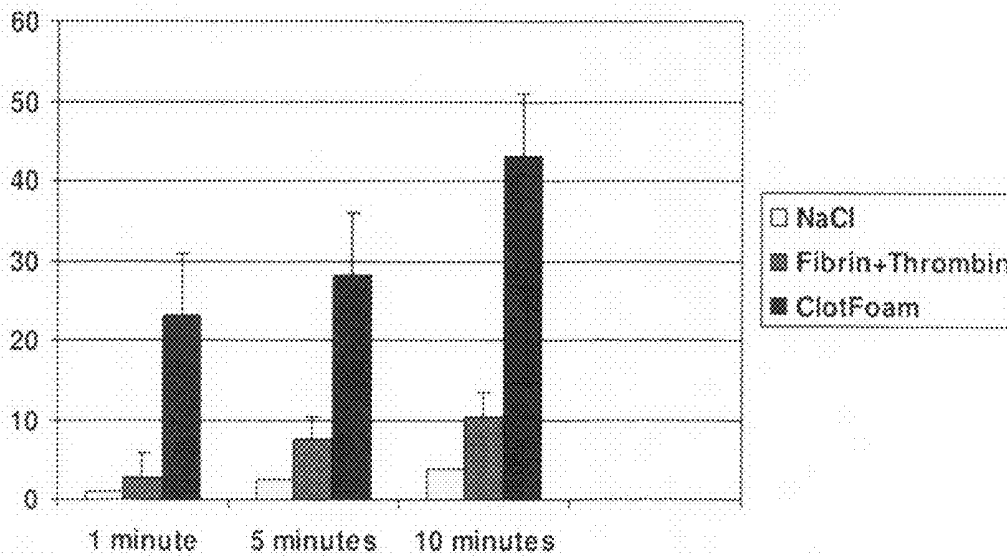

Fig. 4

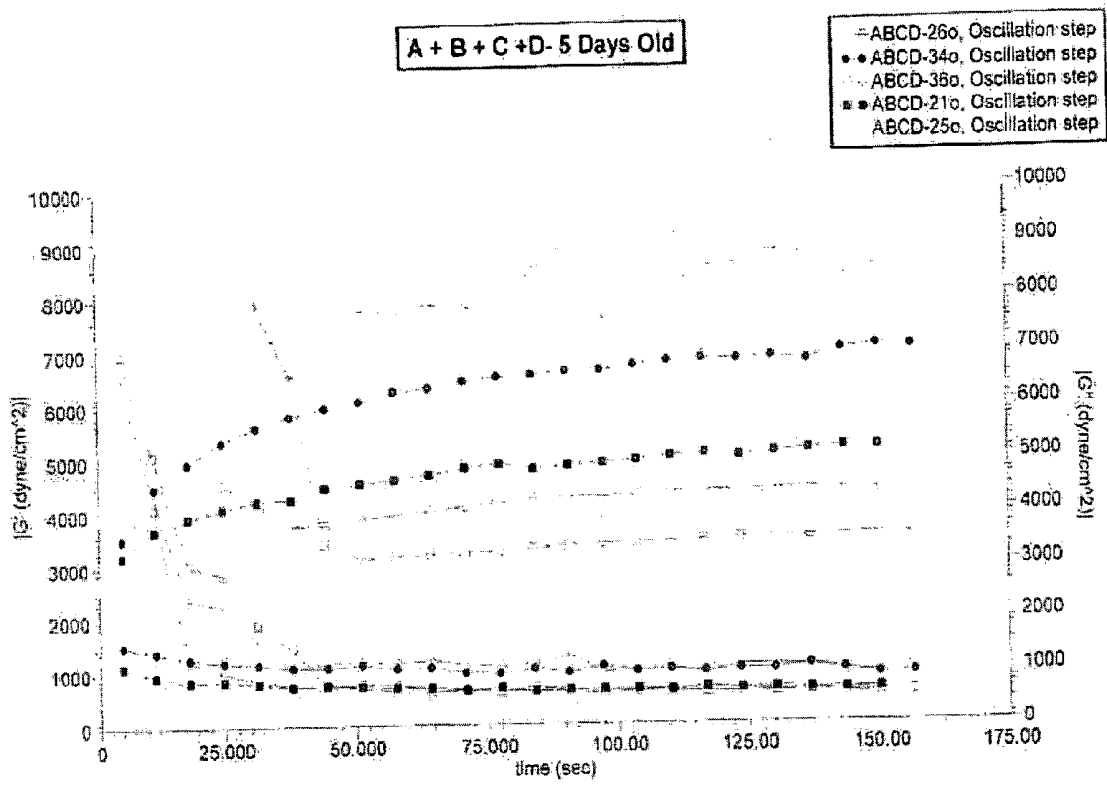

Fig 5

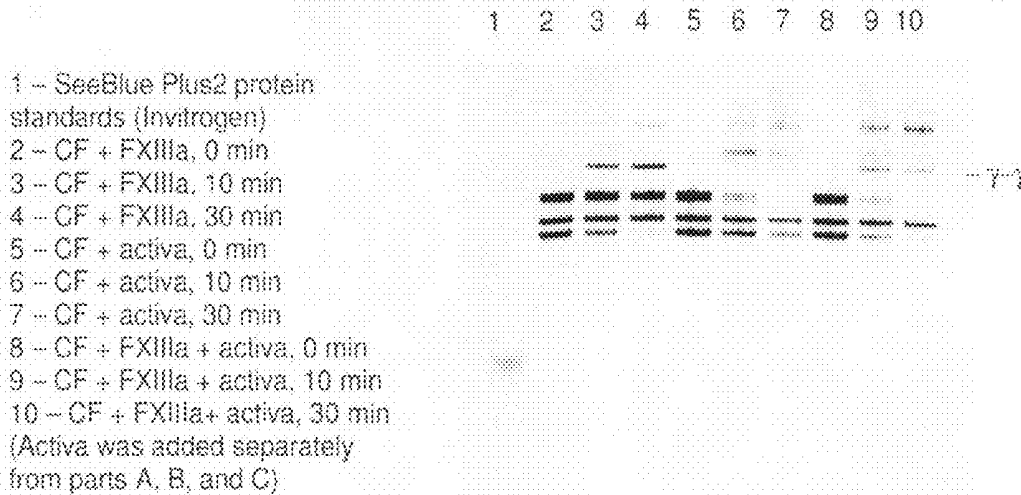

Fig. 6

- Fibrin Monomer galena 30 days
- Fibrin Monomer RT 4 days W NaN3
- Fibrin Monomer RT 4 days
- Fibrin Monomer RT 1 day
- Fibrin Monomer 1 4°C 8 days
- Fibrin Monomer 40C 0 days
- Fibrin Monomer + B 60 days
- Fibrin Monomer + A 60 days
- Fibrinogen sample
- Ladder

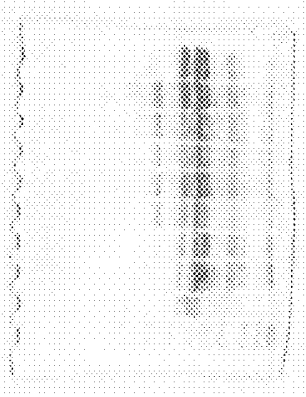

Fig. 7

Clotability of fibrin-monomer

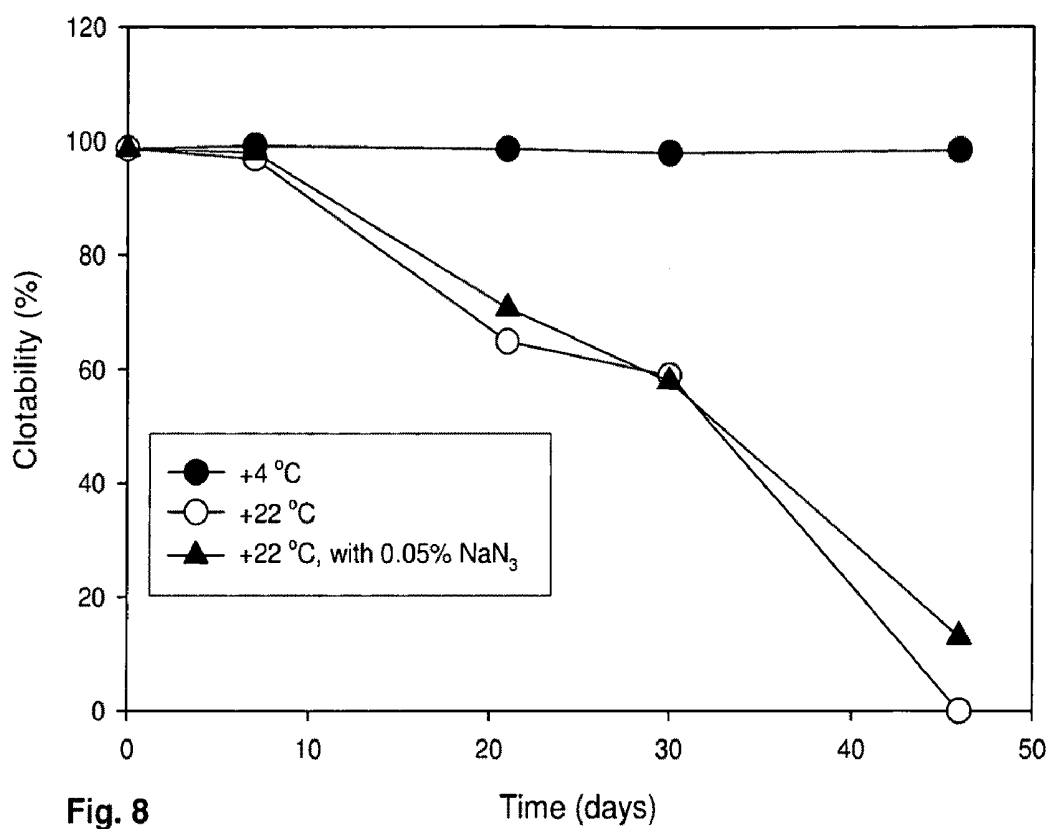

Fig. 8

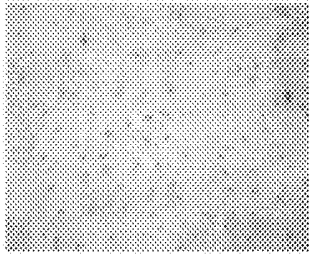

Fig. 9

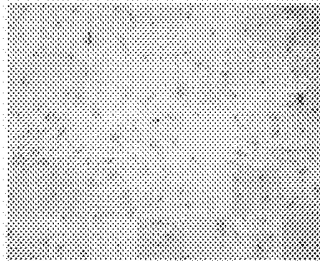

Fig. 10

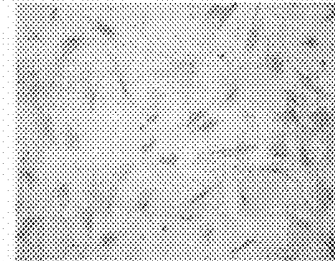

Fig. 11



Fig. 12

Damaged area is tightly closed

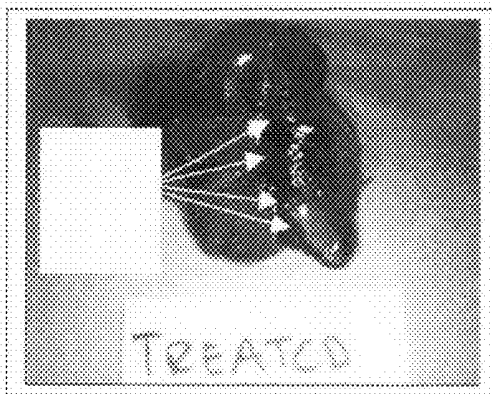

Fig. 13

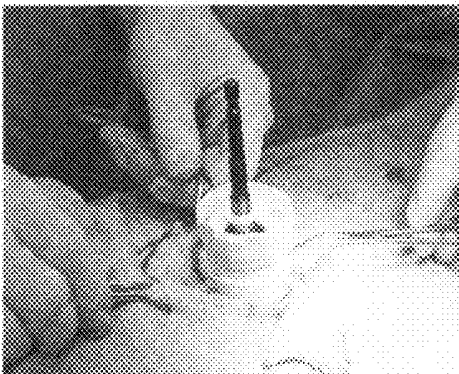

Fig. 14



Fig. 15

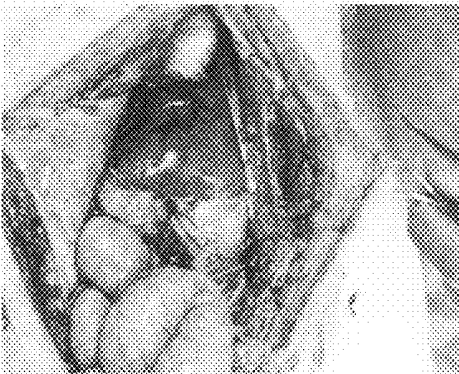

Fig. 16

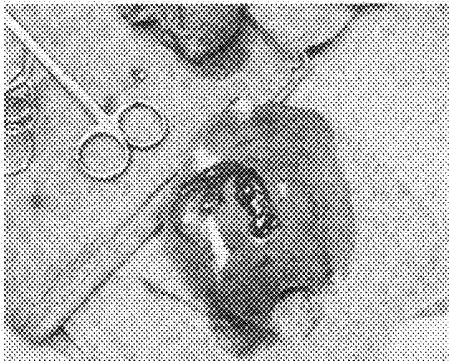

Fig. 17

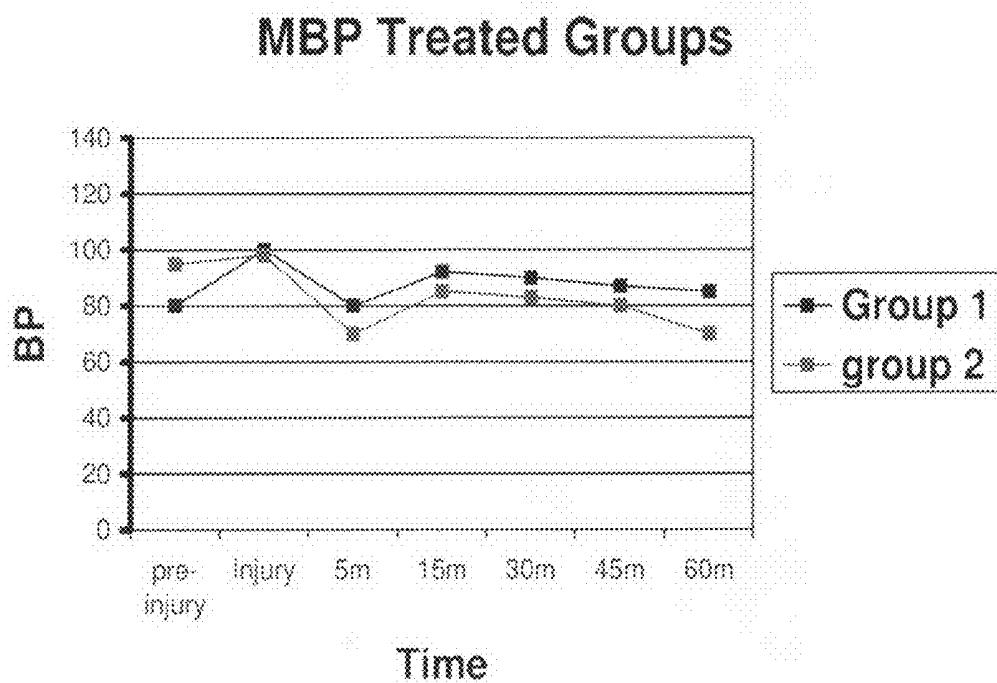

Fig. 18.

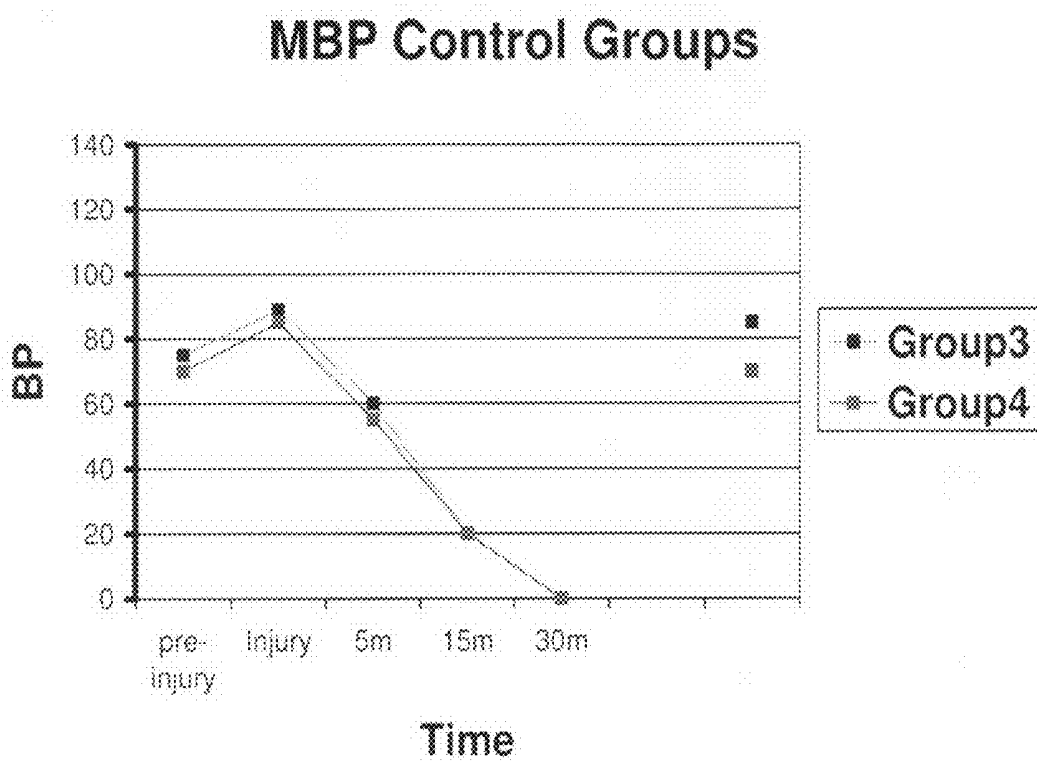

Fig. 19

## TISSUE SEALANT FOR USE IN NON-COMPRESSIBLE HEMORRHAGE

### FIELD OF THE INVENTION

**[0001]** The present invention which has been trademarked as ClotFoam®, is generally related to an adhesive sealant composition and hemostatic agent which may be used to bond or seal tissue in vivo without compression, stitches or staples. It is particularly related to a four component in liquid state which are mixed together as it is applied to tissue and then cured in vivo in order to bond tissue, to seal tissue to prevent or control intracavitary or internal hemorrhage. More specifically, it is a modification of patent application Ser. No. 12/419,734 Title of Invention: Tissue Sealants for Use in Non-Compressible Hemorrhage Date: Apr. 7, 2009

### BACKGROUND OF THE INVENTION

**[0002]** Traumatic injury is a frequent cause of morbidity and mortality worldwide. Over 40% of the trauma cases admitted at hospitals in the USA is due to road traffic accidents. Hemorrhage is the primary cause of death on the battlefield in conventional warfare (1). The vast majority of these deaths occur in the field before the injured can be transported to a treatment facility (2). Almost 50% of combat fatalities in Iraq and Afghanistan, and up to 80% of civilian trauma fatalities within the US, are attributed to uncontrolled hemorrhage (3).

**[0003]** The major causes of death in this group are hemorrhage (50%) and neurological trauma (36%), whereas the rest are from devastating multiple injuries. Even when the injured survive long enough to be transported to a medical facility, hemorrhage still remains the leading cause of late death and complications (2). Abdominal injuries pose a formidable problem, especially in young adults (4-8). Being the largest solid organs within the abdomen, the liver and the spleen are the most frequently injured organs (9-10).

**[0004]** Massive bleeding from the liver is currently controlled by Pringle's maneuver or packing of the wound, both of which procedures require surgical intervention and cannot be applied in the battlefield or at the site of accident (11, 12). Spleen trauma can bleed profusely with minimal injury (10-12). Early and effective hemorrhage control can save more lives than any other measure. But since all current haemostatic agents for intracavitary bleeding are designed to be used in the operating room with the cavity wide open (13), not in an emergency at the site of accident or in the battlefield, hemorrhage is often lethal. Also certain types of surgery such as laparoscopic procedures or brain surgery, as well internal bleeding that today require compression could be treated in a less invasive manner.

**[0005]** Current solutions and limitations. Biological glues which can adhere to tissues are known. In general, the synthetic adhesives are used for the tight sealing of vessels or of lungs and for "gluing" the edges of skin incisions. These glues are eliminated, in general after the cicatrization of the wound, by biodegradation, absorption or by simple detachment in the form of scabs. Various technologies have been developed for the formulation of tissue adhesives. Some of them are of synthetic origin, such as the glues based on cyanoacrylates (2-butyl cyanoacrylate, 2-octyl cyanoacrylate), or on synthetic polymers, and others contain biological

materials such as collagen or fibrin which in addition have hemostatic properties and also act by controlling bleeding.

**[0006]** As a result of their hemostatic and adhesive properties, sealants, and particularly fibrin sealants have been extensively used in most surgical specialties for over two decades to reduce blood loss and post-operative bleeding because of the ability to adhere to human tissue as it polymerizes (14, 15, 16). These compounds are used to seal or reinforce wounds that have been sutured or stapled; they can also be used with pressure over an injured area. Fibrin sealants are biological adhesives that mimic the final step of the coagulation cascade. (13)

**[0007]** There are several commercial products available (FloSeal, Gelfoam, Evicel) (16-18). However, these products have significant limitations which have prevented their widespread use in emergency medicine (trauma) and laparoscopic surgery. All existing haemostatic agents for intracavitary bleeding are designed to be used in the operating room and not in an emergency, e.g. at the site of accident or in the battlefield and all require compression. One of the major limitations encountered in the development and/or use of tissue adhesive and sealant compositions for non-compressible hemorrhage is their inability to form a sufficiently strong bond to tissues and to develop a method of application. Therefore, tissue adhesives and sealants have to be employed in combination with compression methods, sutures and/or staples so as to reduce the tissue-bonding strength required for acceptable performance. However, there are many situations where the use of sutures and/or staples is undesirable, inappropriate or impossible. The difficulty of the adhesive matrix to form a strong interface or bond with tissues is most likely due to several factors: The intracavitary free blood or flowing blood does not allow the compounds that promote coagulation to reach the bleeding source, and various proteins in the tissue are not readily amenable to non-covalent and/or covalent interactions with the tissue adhesive or sealant components as applied and/or during and after curing. As a result, for most tissues and adhesive and sealant systems, failures are generally believed to occur at the interface between the cross-linked adhesive matrix and one or more tissue-associated proteins such as collagen, actin and myosin (19, 20).

**[0008]** The present alternative approach: Clotfoam. Agents that can achieve hemostasis without compression and/or sutures are required to stop bleeding from severe intracavitary trauma outside the operating room. Non-compressible technologies are also useful in the operating room where compression cannot be applied (e.g. laparoscopic surgery, neurosurgery, etc.). In order to resist the flow of blood, the adhesive matrix must form in a matter of seconds a strong interface and bond with tissues in the midst of flowing blood and remain at the lacerated site to form a clot. As described in patent Application Number 12419734, the ability of the present agent to adhere to human tissue is related to the internal structure of the scaffold carrying the fibrin sealant that translates into the necessary viscoelastic and adhesive properties as it polymerizes. Rapid formation of the hydrogel, a minimum polymerization time to produce an adhesive gel that contains the necessary components to develop a functional fibrin clot over lacerated bleeding tissue is clinically important. Instant tissue sealant adhesion is desirable to ensure that the sealant functions on contact and remains at the site of application without being washed away by blood or displaced by movement of the target tissue. (21)

- [0009] In our approach these functions are met through a) the in-situ generation of a three-dimensional polymeric cross-linking chemistries network that is bonded to the tissue by non-covalent bonds, and b) the viscoelastic characteristics of foam, producing a very sticky matrix that attaches to lacerated tissue and wet surfaces; and c) the instant formation of a strong fibrin clot stabilized by Calcium independent transglutaminase enzyme ACTIVA. Stickiness and other viscoelastic properties contribute substantially to the ability of the fibrin polymer to stimulate the coagulatory cascade, form a blood clot and achieve hemostasis.
- [0010] Composition. ClotFoam incorporates fibrin monomer in solution ready to polymerize at change of pH produced by the dialysis method, which is embedded in a hydrogel scaffold. The scaffold is cross-linked in the presence of activated transglutaminase enzyme (calcium dependant and Calcium independent). Both polymers, fibrin and scaffold, when cross-linked in situ, fulfill three objectives or functions: a) allow non-invasive application and dissemination of the agent in the peritoneal or other body cavities; b) adhere and compress lacerated or wound tissue to prevent flow of blood; and c) maintain over the wound the necessary components to produce a fibrin clot and stimulate the coagulatory cascade.
- [0011] The scaffold uses gelatin as the "structural" protein cross-linked with biological polymers to achieve a specific viscoelastic profile that is ideal for carrying the fibrin monomer and for neutralizing its pH in order to polymerize it. (21, 22). When polymerized by the mixing of the parts, fibrin provides a critical provisional matrix at sites of injury (23).
- [0012] The non-invasive application and dissemination is based on the production of foam upon mixing the components, which once injected spreads throughout the cavity reaching the lacerated tissue to stimulate the blood coagulation cascade. Other important differences with existing gels are that the proposed adhesive uses as a cross-linked structural protein, Teleostean fish gelatin Type A, Bovine serum albumin (BSA, protein), Carbomer 934 (polyacrylic acid crosslinked with perylene diimide), a calcium-independent crosslinking catalyst (ACTIVA) and alternative materials such as polysaccharides and polyvinylpyrrolidone, Carrageenan (sulfonated polysaccharide) sucrose,  $MgCl_2$ , with or without Alginate, Carboxymethyl cellulose, providing better and "intelligent" cross-linking chemistries that modify the liquid-gel state and viscosity as needed.
- [0013] The ability of the matrix to achieve hemostasis depends not only the formation of fibrin itself, but also on interactions between specific-binding sites on fibrin, pro-enzymes, clotting factors, enzyme inhibitors, cell receptors and, equally importantly, the dynamics of distribution and viscoelastic attachment properties of the foam (24, 25). The activity of these factors can be enhanced or improved to produce a strong clot able to stop the parenchyma bleeding in the spleen, liver and other solid organs in the abdominal cavity, cranial cavity, and soft tissue. Each part is formulated to maximize the activity of fibrin clot component.
- [0014] The instant gelation of the scaffold and its ability to rapidly produce a fibrin clot is essential to ensure that the sealant remains at the site of application without being washed away by blood or displaced by movement of the target tissue (19). Under coagulant conditions, ACTIVA, as well as  $Ca^{2+}$ ,  $Mg^{2+}$  and  $Zn^{2+}$ , contribute to this process by stabilizing the fibrin clot through covalent bonds. (24)
- [0015] Key Attributes. Polymerization/Adhesion. The gel foam is formed as a result of the covalent cross-linking of the gelatin chains, serum albumin and carbomer 934 in the presence of sucrose, metallic ions, and calcium independent transglutaminase enzyme. [24]. The gel carries and supports the polymerization of fibrin monomer in solution, which is stabilized by  $Ca^{2+}$  and ACTIVA into a fibrin clot within 1 minute of application. The clot is mechanically stable, well integrated into the scaffold, [25] and more resistant to lysis by plasmin compared with an uncross-linked clot [26] or other fibrin sealants. Components of the scaffold together with ACTIVA facilitate the transglutaminase-mediated oligomerization of the  $\alpha C$ -domains of fibrin promoting integrin clustering and thereby increasing cell adhesion and spreading, which stimulates fibrin to bind  $\alpha v\beta 3$ -,  $\alpha v\beta 5$ - and  $\alpha 5\beta 1$ -integrins on EC (27). The oligomerization also promotes integrin-dependent cell signaling via focal adhesion kinase (FAK) and extracellular signal-regulated kinase (ERK), which results in an increased cell adhesion and cell migration, over time, powered by the effects of fish gelatin on fibroblast differentiation [28]. The presence of additional  $Ca^{2+}$  and Zinc enhance the progression between the inflammatory response and the coagulation cascade (first stage).
- [0016] Gelling time, gel strength measured by rheometry, ability to maintain contact adhesion in wet surfaces and rapid polymerization of the fibrin monomer and stabilization (formation of covalent bonds in the presence of ACTIVA) to achieve a functional fibrin clot is clinically important. High tensile strength and adhesive strength are mechanical properties characterizing the gelatin-fibrin polymeric network produced by the agent, which is necessary for successful sealing (29).
- [0017] The adhesion characteristics to vital human tissue and the kinetics of polymerization of the proposed agent have been tested in vitro and in vivo. The data obtained provides ample evidence of the ability of Clot Foam to stop bleeding and achieve hemostasis with no compression in induced intraperitoneal non-compressible secondary to grade IV traumatic liver damage in rodents and swine models. Depending on the protein concentrations, dilution and catalysts, the gel process begins within 6 seconds of mixing the liquid solutions, reaching gel strength of  $7,000 \text{ dyn/cm}^2 \pm 1,000 \text{ dyn/cm}^2$  in 20 seconds. Gel state remains stable between 10 to 20 minutes depending on the concentration of surfactants (tween 80) and pH to finally return of the liquid state. This final state transition facilitates absorption and elimination of agent from the cavity. Studies of tensile static and dynamic loading of the adhesive hydrogels in bulk form demonstrated that the Young's modulus ranged from 45 to 120 kPa and that these bulk properties were higher than to those reported for hydrogels obtained from fibrin-based sealants (28). Even after being washed away, strands of ClotFoam remained attached to both of the opposing lacerated tissues.
- [0018] Protein gelation. Another important component that ensures the binding of the three-dimensional polymeric network to the tissue surrounding the wound is the structural protein. ClotFoam contains Teleostean Gelatin type A in liquid phase. The raw material for the production of this gelatin is the skin from deep water fish such as cod, haddock and

Pollock. It is a protein derived by a mild partial hydrolysis at relatively low temperature from collagen.

**[0019]** The uniqueness of fish gelatin lies in the amino acid content of the gelatin. Although all gelatins are composed of the same 20 amino acids, there can be a variation in the amount of imino acids, proline and hydroxyproline. With lower amounts of these imino acids, there is less hydrogen bonding of gelatin in water solutions, and hence a reduction in the gelling temperature. Gelatin from cod skin gels at 10° C., whereas gelatin from carp skin would be more similar to animal gelatin, which gels above room temperature. Two of its most useful properties are gel strength and viscosity (30).

**[0020]** Biomacromolecules like gelatin have emerged as highly versatile biomimetic coatings for applications in tissue engineering (31). The steady-state adhesion energy of 3T3 fibroblasts on gelatin film is three times higher than that on chitosan film. The better attachment of 3T3 fibroblast to gelatin is postulated to be caused by the presence of adhesive domains on gelatin. Thus, bio-absorbable gelatin and polysaccharides can be used to prepare a safer and stronger hemostatic gel (32).

**[0021]** The sealing effect of rapidly curable 3D network of gelatin-Fibrin-BSA hydrogel glue on lacerated tissue has been studied in our laboratory. Upon mixing of the polymer components in aqueous solution, Schiff base is formed between the amino groups in the modified gelatin and the aldehyde groups in the modified polysaccharides, which results in intermolecular cross-linking and gel formation. The gel formation can take place within 5 seconds, and its bonding strength to it is about 225 gm cm<sup>-2</sup> when 20 wt % of an amino-gelatin (55% amino) and 10 wt % of aldehyde-HES (>84% dialdehyde) aqueous solutions were mixed. Hydrogel glue resulted in superior sealing effect.

**[0022]** Gelatin is widely used in medical applications. Together with water, it forms a semi-solid colloidal gel. It has been already used in several life supporting applications such as plasma expanders and blood substitutes. (31) Gelatin has been suggested as a low effect molecule in the hemostatic variables when utilized as a volume-blood substitute intravenously in hemorrhagic shock (33). This molecule has been related as an excellent natural attachment site for cells as well as a material with a high degree of biocompatibility and readily available to incorporate agents to it that are related to the wound healing process and coagulation.

**[0023]** Viscoelastic properties. Viscosity and elastic moduli at the gel point vary at differing gelatin, carageneen, carbomer and active concentrations. These parameters provide a measure of the flow properties and gel strength at a single time, the gel-point, and provide an indication of optimal distribution of the foam in the cavity and ability to spread throughout the cavity stick to the lacerated tissue and trigger the blood coagulation cascade. The optimal concentration of components as described below allow the adhesive to flow into and mechanically "interlock" or stick to the tissue in order to seal the wound. While a lower viscosity adhesive may lack sufficient cohesive strength to be retained where it is applied and it may be washed away, a higher viscosity formulation may not produce sufficient foam to cover the cavity or be fluid enough to reach the tissue. This problem can be particularly important if the adhesive must be applied to wet tissue. In addition, stronger gels or gels that polymerize faster

have greater cohesive strength but might not effectively penetrate and interlock with tissue. Thus, the adhesive's flow properties and gel strength are practically important and the values are defined by the intracavitary non-compressible situation in which an organ or tissue is perforated. (19-21).

**[0024]** The sticky, gummy consistency of the agent maintains the foam in situ over lacerated tissue despite the flow of blood, while PVP and other large molecules enhance the physical adhesion of the foam to wet tissue. The foam property allows for more extensive attachment than would be achievable from a homogeneous liquid form and also provides a scaffold for the growing fibrin network that binds sundered tissue and forms a barrier to blood flow. The incorporation of commercially available bacterial- or plant-derived carbohydrate-based gel components can be used to further enhance the property of ClotFoam. Lo-acyl Gellan gum with calcium ion, alginate acid (pKa=5), and carrageenan with locust bean gum and potassium ions, known to form robust hydrogels, can also be added to better achieve hemostasis in pooled blood.

**[0025]** Fibrin monomer polymerization: An experimental method for producing fibrin monomer was first described and published by Belitser et al (1968, BBA) (34). Such method limits the production of monomer to a few milligrams per day. The preparation, properties, polymerization, equilibria in the fibrinogen-fibrin conversion, solubility, activation and cross-linking of fibrin monomer has been studied by several authors since 1968 (35-43). Although U.S. Pat. No. 5,750,657 to Edwardson et al. describes a method of preparing a fibrin sealant utilizing a fibrin monomer composition, the Clot-Foam sealant composition, neutralization of the fibrin monomer to produce a polymer, and use of fibrin monomer produced by the dialysis method, is entirely novel. A non-provisional patent application, describing a commercially viable method for producing fibrin monomer in solution in industrial quantities was filed with the patent Application Number: 12487057 "A Method to Produce Fibrin Monomer in Acid Media for Use as Tissue Sealant" Date: Jun. 18, 2009. The composition of parts and method of production of the fibrin monomer are critical to the performance of a non-compressible technology. The power to stick to the lacerated tissue in a pool of blood depends on the cellular and matrix interactions. The characteristics of the fibrin itself, such as the thickness of the fibers, the number of branch points, the porosity, and the permeability and other polymerization characteristics define the interactions between specific-binding sites on fibrin, pro-enzymes, clotting factors, enzyme inhibitors, and cell receptors [24]. Chloride and Zn ions have been identified as modulators of fibrin polymerization, because these ions control fiber size by inhibiting the growth of thicker, stiffer, and straighter fibers.

**[0026]** pH-Studies conducted by other investigators (34) and our own investigations, demonstrated that a pH and ionic strength dependency on polymerization and crosslinking of the scaffold and fibrin monomer and therefore clot formation existed. pH determines the viscosity of solution comprising the scaffold and the ability of the solution to neutralize the acid pH of monomer solution, thereby producing a polymer that will be stabilized by ACTIVA. Clot foam parts A, B, C and D are formulated to maintain optimal pH to favor the incorporation, preservation and activity of fibrin sealant components; fibrin monomer, and Activa.

**[0027]** Role of the Foam The complementary process that allow the compounds to reach the bleeding source or remain at the lacerated site to form a clot is triggered by an organic non-toxic non-exothermic reaction producing a sticky foam that spread throughout cavity in the same way that sealing foams are use to repair tires. Sodium monobasic phosphate ( $\text{NaH}_2\text{PO}_4$ , is used to buffer pH of Solution B to promote foaming when mixed with part A by acid-base neutralization of the  $\text{NaHCO}_3$  and alginic acid, or Carbomer 934. The volume expansion produced by the foam triggering component is from 300% to 400% of the original volume within 10 seconds of mixing solutions. These time frames, strengths and volumes are convenient in the sense that they allow ClotFoam solutions to generate a foam that is distributed throughout the cavity in the form of a strong gel that adheres (sticks) to the lacerated tissue. Our studies have determined the concentration of components necessary to adjust the gel time and gel phase duration (25).

**[0028]** Role of divalent metal ions. The ClotFoam kit in its present form contains Calcium, Zinc and Magnesium ions. It has been established that these ions can markedly increase the rates of fibrin polymerization, and the length and strength of fibrin filaments. The presence of additional  $\text{Ca}^+$  and Zinc enhance the progression between the inflammatory response and the coagulation cascade.  $\text{Zn}^+$  modulates fibrin assembly and plays a role in the activation of thrombin-activatable fibrinolysis inhibitor.

**[0029]** Role of Activa: This Ca independent transglutaminase enzyme has the double role of crosslinking the gelatin-based polymer and the fibrin polymer.

#### “SUMMARY OF THE INVENTION”

**[0030]** The present invention lies within the domain of biological adhesives and tissue sealants, which are biodegradable and nontoxic, intended for therapeutic use, for example, as an intracavitary hemostatic agent for non-compressible hemorrhage.

**[0031]** In one aspect, the present invention relates to biocompatible fluid adhesive protein foam as well as to biocompatible fluid/foam adhesive, which is bio-reabsorbable and nontoxic, for surgical or therapeutic use. It also relates to such foam containing bioactive substances which can be released in a given site.

**[0032]** In another aspect, the invention relates to a process for producing such an adhesive foam and to a device to deliver such preparation

**[0033]** Extensive in vivo studies show that ClotFoam is an excellent hemostatic agent candidate for emergency situations and combat trauma as well for non-invasive surgical procedures. If needed it can be applied by paramedics, it is durable, possess minimal risk, require little training to use, is effective against severe bleeding that would otherwise lead to exsanguination, and capable of sustaining hemostasis for at least several hours to permit safe evacuation to definitive care centers. The application through a “mixing needle” specially designed for non-invasive use is safe, and can be performed in the battlefield or in a medical facility. Thus, ClotFoam is a novel concept since there is no other compound that can be delivered through a needle in a minimally invasive procedure, reaching the injured tissue within the abdominal or other cavity through pooled or flowing blood.

#### BRIEF DESCRIPTION OF THE DRAWINGS

**[0034]** FIG. 1 ClotFoam 4-parts applicator and mixing needle

**[0035]** FIG. 2. Mechanism of action

**[0036]** FIG. 3 Diagram of 4-parts component Interaction

**[0037]** FIG. 4. Graph of intratissular adherence measured in  $\text{gr}/\text{cm}^2$  comparing ClotFoam fibrin monomer technology against the current available sealants made of fibrinogen and thrombin mixed in situ.

**[0038]** FIG. 5 Rheometry of current formulation using carbomer as a gelatin crosslinking agent showing a  $G'$  or storage energy over  $6000 \text{ dyne}/\text{cm}^2$

**[0039]** FIG. 6 Polymerization, cross-linking and stabilization of fibrin when the four parts of ClotFoam are mixed in the presence of ACTIVA and Factor XIII. Western Blot

**[0040]** FIG. 7 Western blot of fibrin monomer polymerization capacity over a 60-storage period.

**[0041]** FIG. 8. Clotability strength of fibrin monomer at various temperatures over a 50-day period

**[0042]** FIG. 9 Microphotography of fibroblast growth in media containing Clot Foam day-0 (biocompatibility)

**[0043]** FIG. 10 Microphotography of fibroblast growth in media containing Clot Foam day-3 (biocompatibility)

**[0044]** FIG. 11 Microphotography of fibroblast growth in media containing Clot Foam day-7 (biocompatibility)

**[0045]** FIG. 12 Livers were removed for observation of the lesions and clot forming effect in control ( $\text{NaCl}$ ).

**[0046]** FIG. 13 Livers treated with ClotFoam show the formation of very strong clots in the injured areas

**[0047]** FIG. 14. Grade IV liver injury produced by a drill through a laparoscopic procedure and closed cavity ClotFoam application (pig model)

**[0048]** FIG. 15 Blind application of the 4-part Clotfoam through the port.

**[0049]** FIG. 16 Opening the cavity after 60 minutes showing the clot formation and bleeding control.

**[0050]** FIG. 17. Measurement of the blood clot and strength.

**[0051]** FIG. 18. Trend of mean arterial pressures (MAPs) in liver grade IV injury treated with clotFoam (swine model)

**[0052]** FIG. 19. Trend of mean arterial pressures (MAPs) in liver grade IV injury not-treated (swine model)

#### DETAILED DESCRIPTION

**[0053]** We have developed an intracavitary hemostatic agent in liquid form, CLOTFOAM®, and a method of application for the use in non-compressible hemorrhage outside the operating room or in non-invasive surgical procedures.

**[0054]** ClotFoam is a novel liposomal gel carrying a fibrin sealant, which is designed to promote hemostasis in cases severe bleeding and to stop hemorrhage without compression resulting from organ resection, trauma and/or intracavitary wounds grade IV/V or, solid organ wounds, soft tissue and brain that otherwise may lead to clinical complications or exsanguinations. CLOTFOAM® is intended to be used specifically but not exclusively as an hemostatic agent for emergency situations and combat trauma, and for minimally invasive surgical procedures such as laparoscopic surgery; and cosmetic surgery. This sealant agent promotes coagulation and provides hemostasis as well as adhesiveness between surfaces of damaged tissue. ClotFoam is a novel concept since there is no other compound that can be 1) delivered through a laparoscopic port or a wound entrance, 2) achieve hemostasis within 10 minutes of application without compression in minimally invasive

procedures and sustain hemostasis for one hour in cases of very severe intracavitary trauma, 3) used when sutures and/or staples are undesirable, inappropriate or impossible, and stop the bleeding and promote early adherence of damaged tissue, and 4) reach the injured tissue within the abdominal cavity through pooled or flowing blood. CLOTFOAM can be used: a) immediately after trauma in the battlefield or at the site of the accident; b) can be applied by paramedics; c) can maintain its viscosity at a wide range of temperatures.

**[0055]** CLOTFOAM is a kit (FIG. 1) comprising of four parts solubilized in aqueous medium than when mixed and delivered by a pneumatic operating device form and adhesive compound of a 3D-complex hydrogel (scaffold) carrying fibrin monomer, which is polymerized/crosslinked, by a reaction with the scaffold, and stabilized by ACTIVA.

**[0056]** The process that allows the agent to reach the bleeding source or remain at the lacerated site to form a clot is initiated by the mixture of liquid components A, B, C, and D that form a gel. Once the solutions are mixed, they produce a non-toxic low-exothermic reaction that leads to a sticky foam (hydrogel). This foam spreads through out the cavity in the same way that sealing foams are use to repair tires. The sticky, gummy consistency of the agent maintains the foam in situ over lacerated tissue despite the flow of blood, rapidly forming an adhesive matrix over damaged tissue that 1) seals the wound with a solid cap, 2) triggers the coagulatory cascade to form a blood clot by introducing a barrier along the wound, and 3) attaches to the lacerated tissue by a non-covalent action. (FIG. 2)

**[0057]** The hemostatic properties of CloFoam formulations are based on the physical and coagulation properties of a scaffold (PART A+PART B) mixed with fibrin monomer in acid solution (PART C), and with ACTIVA (Part D), which stabilizes the fibrin polymer. The hydrogel scaffold consisting of a mixture of Teleostan Gelatin type A in liquid phase, Bovine serum albumin (BSA, protein), Polyvinylpyrrolidone (PVP) crosslinked by, but not exclusively, Carbomer 934 (polyacrylic acid) in the presence of calcium independent transglutaminase enzyme Activa, Carrageenan type 2, and Sucrose mixed with a water-soluble foam inducer of sodium bicarbonate and dihydrogen phosphate. Other crosslinking agents are Alginic acid (polysaccharide), and Carboxymethyl cellulose albumin. Part C (fibrin monomer solution in acetic acid) is polymerized by pH neutralization once it is mixed with part A (pH 8.4) and then stabilized by Part D (ACTIVA).

**[0058]** Foaming enhancers such as sodium lauryl sulfate, sodium lauroyl sarcosinate, taurate salts and betaine surfactants can be added. Ca, Mg and Zn ions, enhance the polymerization reaction. ACTIVA can be substituted by Factor XIII.

**[0059]** The mechanism of action illustrated in FIG. 3 shows how Part A mixed with part B cross-links gelatin and BSA to form a strong foaming (liposomal) hydrogel that expands the original volume by 400%. While the gel is being formed, fibrin monomer (PART C) is polymerized by a change of pH (7.2), or neutralization triggered by Part A (pH 8.4). Part D delivers the calcium ions and ACTIVA necessary to stabilize the monomer. The ability to remain at the site despite the flow of blood, form a matrix exclusively over lacerated tissue and seal the wound is achieved through a) the surface adhesion and viscoelastic characteristics of a foam components, pro-

ducing a very sticky matrix carrying the fibrin polymer that attaches to lacerated tissue and wet surfaces and contributes substantially to the ability of the agent to achieve hemostasis, and b) the in situ generation of a three-dimensional polymeric cross-linking chemistry network in the presence of ACTIVA and calcium ions that forms a fibrin clot which is bonded to the tissue.

**[0060]** The four parts are required in order to preserve the activity of components, prevent chemical reactions among them, and maintain the pH.

**[0061]** The components that contribute the formation of the foam are: sodium bicarbonate, dihydrogen phosphate, Carbomer 934 and foaming enhancers such as sodium lauryl sulfate, sodium lauroyl sarcosinate, taurate salts and betaine surfactants

**[0062]** The Following components provide the physical viscoelastic properties: Teleostan Gelatin type A in liquid phase, Bovine serum albumin (BSA, protein), Carrageenan type, Polyvinylpyrrolidone, Sucrose and Carbomer 934. The complementary presence of additional Ca, Mg and Zinc ions enhance the polymerization process.

ClotFoam Formulation.

**[0063]** ClotFoam is produced by the combination of 4 solutions: A, B, C and D

Solution A:

Step 1. Preparation of Neutral A:

**[0064]** micromolar range of ZnCl

**[0065]** Millimolar range MgSO<sub>4</sub>

**[0066]** Teleostan cold water fish gel

**[0067]** sucrose

**[0068]** polyvinylpyrrolidone

**[0069]** H<sub>2</sub>O,

**[0070]** all contents are stirred to homogeneity and then the solution is

**[0071]** neutralized to pH 7.1 with NaOH

Step 2. Preparation of Final Solution A

**[0072]** Neutral A" (above)

**[0073]** Carrageenan, type 2 or Locust bean

**[0074]** NaHCO<sub>3</sub>

**[0075]** bovine serum albumin

**[0076]** All components are stirred, resulting in a suspension, which is then homogenized with three strokes of a ounce homogenizer.

**[0077]** All components are stirred, resulting in a suspension, which is then homogenized with three strokes of a ounce homogenizer.

Step 3) Preparation of Solution B

**[0078]** NaH<sub>2</sub>PO<sub>4</sub>

**[0079]** Tris-Base

**[0080]** Carbomer 934

Step 4) Preparation of Solution C

**[0081]** 90-120 mg/ml Fibrin monomer solution in 0.125% ice cold AcOH (pH 3.4) are prepared by dialysis method.

## Solution D

## ACTIVA Dissolved in HEPES Buffer

**[0082]** All parts are sterilized following a method further described. Endotoxins are removed by filtration over polymixin resin Upon mixing of the components A and B in aqueous solution, Schiff base is formed between the amino groups in the modified (fish) gelatin used in the CLOTFOAM composition, and the aldehyde groups in the modified polysaccharides, which results in intermolecular cross-linking and gel formation. The gel formation can take place within 5 seconds.

**[0083]** ClotFoam gelatin is produced from fish skin, and it is usually referred to as type 'A' gelatin. The raw material for the production of this gelatin is the skin from deep water fish such as cod, haddock and Pollock. It is a protein derived by a mild partial hydrolysis at relatively low temperature from collagen. Two of its most useful properties are gel strength and viscosity, on which it is mainly assessed.

TABLE 1

Specifications for ClotFoam gelatins:	
pH	3.8-5.5
Isoelectric Point	7.0-9.0
Gel strength (bloom)	50-300
Viscosity (mpa)	15-75
Ash (%)	0.3-2.0

The gelatin type used in the composition of CLOTFOAM is one of the most pure and perfect protein available. Once sterilized, it is absolutely harmless. It is active and readily and rapidly accepted by the body. It is widely used in medical applications. Together with water, it forms a semi-solid colloidal gel. It has been already used in several life supporting applications such as plasma expanders and blood substitutes. (29)

**[0084]** The uniqueness of fish gelatin lies in the amino acid content of the gelatin. Although all gelatins are composed of the same 20 amino acids, there can be a variation in the amount of imino acids, proline and hydroxyproline. With lower amounts of these imino acids, there is less hydrogen bonding of gelatin in water solutions, and hence a reduction in the gelling temperature. Gelatin from cod skin gels at 10° C., whereas gelatin from carp skin would be more similar to animal gelatin, which gels above room temperature. Fish gelatin can be reacted with anhydrides under alkaline conditions, reducing or eliminating the effect of aldehydes as a hardening agent on the gelatin

**[0085]** Boiling hydrolyzes the collagen, and converts it into gelatin. An acid process gives type A gelatin which can negatively interact with other anionic polymers, a chemical feature that gives CloFoam its adhesiveness properties to lacerated tissue.

**[0086]** There is also an important relationship between the temperature at which the fish metabolizes and the properties of the skin and the resultant extracted gelatin. Gelatin derived from the skin of deep cold water fish has lower amounts of proline and hydroxyproline, and as a result, water solutions will not gel at room temperature, but will remain liquid to 8 to 10° C., while most animal gelatin gels at 32° C. This property is useful to produce

a product the capability to be stored at room temperature in its liquid physical state. Also, It is important to be able to keep the solubility of the product in a wide range of temperatures in order to be readily to be activated in any environment of battlefield, whether cold or warm weather.

## Delivery Methods:

**[0087]** ClotFoam is delivered into the cavity by an hydraulic applicator through a mixing needle. (FIG. 1) The mixing needle can be adapted for use in different laparoscopic procedures as for other minimally invasive procedures.

## EXAMPLES

**[0088]** 1. Adhesion and viscoelastic properties: The adhesion characteristics to vital human tissue and the kinetics of polymerization of the gel have been tested in-vitro a ex-vivo studies.

## 1.1. Adhesion Properties

**[0089]** Adhesion and tensile measurements (Intratissular adherence and clot strength) were conducted in Sprague-Dawley rats liver tissue. The liver was chosen because is the most frequently damaged organ in intraperitoneal trauma followed by the spleen. Experimental Models Sprague-Dawley rats (250 to 300 g) were anesthetized. The abdominal cavity was approached medially and the liver was completely dissected out and excised. The liver was chosen because it is the most frequently damaged organ in intraperitoneal non-compressible hemorrhage followed by the spleen. We conducted adhesion and tensile studies with an isometric transducer.

1.1.1 Tensil Measurements: The two largest lobes separated. One lobe was attached to a holder that was fixed later to the isometric transducer. The other lobe was placed in a flat bed of gauze in a container that could gradually be elevated and lowered to produce contact with the piece of liver in the transducer's holder. A damage area of 1 cm<sup>2</sup> was produced in both liver pieces. The formulation to be tested for tissue adherence was deposited between the two pieces. The specimens were placed in contact at a baseline pressure of 0 gr. At various time points (1, 5 and 10 minutes of exposure and contact), the pressure needed to completely separate them was recorded. We tested the current formulation and compared these results with a solution of NaCl as controls and with standard technique used by all available fibrin sealants which mix thrombin and fibrinogen in-situ. The results of the intratissular adherence are depicted in FIG. 4. The force of adherence induced by ClotFoam after 10 min is more than 200% stronger than the control in the intratissular adhesion secondary to the exposition of damaged tissue to the foam. Adhesiveness was measured in gr/cm<sup>2</sup>. All tests were performed at 37° C.

1.1.2 Quantification of Clot strength: To study the strength of the formed clot under the influence of the CLOTFOAM we used the following experimental model: Blood was collected in a test tube previously prepared to contain a strand of cotton suture with a piece of cotton gauze as weight in one end, to maintain that side on the bottom of the tube, and at the other end out of the tube with a loop to hang the strand to the isometric transducer. The strand of cotton suture was included in the blood and allowed to coagulate for 2 minutes. The other end of the strand was fixed to an isometric transducer and then pulled down to measure the force (in grams) necessary to pull up the strand from the clot and test tube.

**[0090]** Clot strength observed in three experimental groups that included: blood plus saline solution (B+S), blood alone

(BA), and blood with the CLOTFOAM (B+Gel). showed a statistically significant ( $P=0.001$ ) difference when the blood was treated with CLOTFOAM as compared to blood alone or blood plus saline.

### 1.2. Viscoelastic Properties Amid Gelation

**[0091]** The viscoelastic properties of the cross-linked polymer pairs forming a gel are critical to the ability of the agent to resist the flow of blood and attach to the lacerated tissue. Efforts to optimize this properties included a) cross-linking of gelatin with polysaccharides that can form strong gels and firmly bond to soft tissue (e.g., alginic acid, Poly-(L-glutamic acid, Hyaluronic acid, Carbomer 934); B) the use of alternative materials (e.g., albumin, poly(ethylene oxide)s, albumin, PVP), c) better crosslinking chemistries (e.g., glutaraldehyde, carbodiimide, Calcium-independent transglutaminase enzyme) and d) more controllable polymerization reactions.

**[0092]** Rheological studies were performed to compare the viscoelastic profiles of ClotFoam formulation amid gelation with various combinations of materials currently used to produce surgical sealants. Gelation studies were conducted with a parallel plate geometry; all samples were transferred immediately after mixing (time  $t=0$ ), and measurement started at  $t=6$  s. For time and stress sweeping tests, storage moduli ( $G'$ ) and loss moduli ( $G''$ ) were monitored as a function of time at a 5 Hz frequency and a 2% stress strain at 37° C. Rheological measurements of ClotFoam composition were compared to:

#### Pair of Structural Polymers

- [0093]** a) Gelatin, alginic acid
- [0094]** b) Gelatin, Hyaluronic acid
- [0095]** c) Gelatin, Poly(L-glutamic acid)
- [0096]** d) Chitosan, alginic acid
- [0097]** e) Gelatin, Carbomer 934

#### The Following Crosslinking Catalysers

- [0098]** a) Calcium-independent transglutaminase enzyme mTg
- [0099]** b) EDC

#### Alternative Materials:

- [0100]** a) Carboxymethyl Cellulose

#### Acrylates

**[0101]** The gelation kinetics and morphological evolution that is considered optimal for this application is rheologically described by a) the intersection of  $G'$  and  $G''$  (crosslinking and change of state from liquid to gel) within 10 seconds following the mixing of components; b) the rapid increase in the value of  $G'$  over 5000 dyn/cm<sup>2</sup> pointing to a strong gel; c) maintenance of a high value of  $G'$  for over 10 minutes and decrease of  $G''$  after 10 minutes that return the agent to a liquid state facilitating its absorption by the cavity fluids, and a tangent value increasing from 0.1 to 0.4 indicating an increasing storage energy over released energy.

**[0102]** FIG. 5 shows the gel strength when Carbomer is used in replacement of alginic acid as crosslinking agent of gelatin and BSA in the current formulation. Rheological measurements of the current formulation indicate that CLOTFOAM catalyzes the conversion of gelatin solutions into hydrogels, and gel times are on the order of 6 seconds.  $G'$

reaches 6000 dyn/cm<sup>2</sup> in less than 20 seconds, while  $G''$  remains below 1000 dyn/cm<sup>2</sup>

### 1.3. Studies on the Effect of Divalent Metal Ions

**[0103]** The effect of  $Ca^{2+}$ ,  $Zn^{2+}$  and  $Mg^{2+}$  on effects on gel, were investigated. It has been established that these ions could increase foam expansion, accelerate gelatin crosslinking, fibrin polymerization, and both enhance the length and strength of fibrin filaments as well as the gel strength.

**[0104]** Characterization of the kinetics is of utility as it may indicate that though a given metal ion addend could enhance gel strength, and drastically decrease crosslinking time of the various polymers included in the 3\_D structure.

**[0105]** Ion testing with Magnesium Chloride and Zinc Chloride—Solutions were made using the original baseline formulation. Ions were added as follows: 20  $\mu$ M  $ZnCl_2$  solution, a 20  $\mu$ M  $MgCl_2$  solution, a 40  $\mu$ M  $ZnCl_2$  solution, a 40  $\mu$ M  $MgCl_2$  solution, a 60  $\mu$ M  $ZnCl_2$  solution, and finally a 60  $\mu$ M  $MgCl_2$  solution by adding 0.002 M  $ZnCl_2$  and 0.002 M  $MgCl_2$  solutions.

**[0106]** The change in gel strength as a function of time was tested by rheometry in the absence of divalent metal ions to establish baselines; followed by adding metals ions at various concentrations that produce maximum effects on clot strength.

**[0107]** Concentration of 20  $\mu$ M and less of  $Zn^{2+}$  increased gel strength by an estimated 15%-20%, and decrease the gel time as observed by the slope of  $G'$  and  $G''$ , and enhanced the adhesiveness of the scaffold, which was estimated by a tactile observation using latex gloves. Test for displacement were performed using a 50 mL graduated cylinder.

**[0108]** Results: The 20  $\mu$ M  $MgCl_2$  solution showed the best improvement in volume displacement and adhesive strength.

### 2. Foam Volume Expansion

**[0109]** Methods: An analytical method for determination of foam volume expansion was devised and validated. Optimal volume expansion of foam was achieved with the addition of metallic ions and acrylic acids, by alterations of the initial pH values of the two constituents. The volume varies from 400% to 500% expansion.

**[0110]** The formulation incorporates biocompatible agents that produce foam both by means of chemical reaction. The foam producing approach is harmless and avoids putting tissues in contact in microenvironments with solutions that breach the extremes of physiological pH that gives rise to undesirable irritation and adhesions.

**[0111]** Methods: The foaming capacity was quantified by measuring bulk volume, after polymerization, of a known weight of reactants, as displacement by gel in a volume of inert solvent such as hexane or  $CCl_4$ . This value was compared to a control formulation, based on bicarbonate and acetic acid.

**[0112]** Each sample was tested 3 times. 1 mL of solution A was simultaneously added to 1 mL of solution B in a 16x100 mm test tube using two 1 mL disposable BD syringes. Each mixture was vortexed for 5 seconds immediately after mixing. Displacement tests were performed 20 minutes after vortexing and were tested using the highest point of foaming marked by a sharpie on the test tube. The test tube was lowered into a 50 mL graduated cylinder containing 40 mL of acetone until the bottom of the meniscus of the acetone was

aligned with the sharpie mark and the displacement in mL was noted. Stickiness tests were performed 40 minutes by shear test after vortexing to ensure the solutions had reached their heightened adhesiveness.

3. Fibrin Polymerization

[0113] We conducted molecular chemistry assays to compare the effectiveness of fibrin monomer (Part C) polymerization (pH Neutralization) by the Parts A and B of the gel composition versus fibrinogen polymerization by Thrombin. We also compared the stabilization of the fibrin polymer with ACTIVA (part D) versus factor XIII.

3.1. Polymerization of Fibrin within the Clotfoam Gel

[0114] To test the polymerization rate of the fibrin monomer in ClotFoam when neutralized by components of the scaffold (PART A and B) and to determine the effect is of stabilization by transglutaminase enzymes (FACTOR XIII and ACTIVA, we conducted western blot essays using anti-fibrinogen antibody. The chains of fibrin polymers were detected by the reaction with polyclonal sheep anti-Human Fibrinogen (Fg) affinity purified peroxidase conjugated antibody. (Cat #: SAFG-APHRP, Enzyme Research Laboratory, IN) for 1 hr (1 part in 50K 5% milk in TBST).

[0115] The polymerization of fibrin when all four components of ClotFoam are mixed in the presence either of FXIII or ACTIVA and Ca<sup>2+</sup> is established by the western blot essay shown in FIG. 6. Both enzymes catalyzed fibrin monomer conversion to a stable insoluble fibrin clot.

4. Shelf Life

4.1 Shelf Life of Monomer Part C

[0116] The purpose of these experiments was to establish that monomer does not degrade over time and under standard conditions (4° C. and 22° C.).

[0117] Fibrin monomer was prepared by dialysis of fibrin polymer against 1 liter of 0.125% acetic acid for 20 h with two changes of the dialysis solution (each in 1 h). Fibrin monomer was concentrated to 17.6 mg/ml. Final yield—80%. Fibrin monomer was then divided into 3 portions, one was kept at 4° C., the other two, one of which contained sodium azide, were kept at room temperature (22° C.); sample for the analysis have been withdrawn at the indicated time.

[0118] The shelf life of Fibrin monomer was analyzed by SDS-PAGE and stained with Imperial Protein Stain (Thermo-Scientific). The analyses of these samples were performed after 1, 4 and 15 days and compared with the Fibrin monomer samples obtained by independent method (Medved & Oglev, unpublished data) and stored for over 30 days at 4° C. FIG. 7.

4.2. Clotability

[0119] SDS-Page data show that there no visible fibrin degradation over time neither at 4° C. or 22° C. Clottability

studies by the absorption method shows that the monomer maintains stability over 6 weeks, while at 22° C. stability is maintained over week. Conclusion the fibrin monomer produced by either method described in this patent can be stored at 4° C. for over 60 days. (FIG. 8)

5. Sterilization

[0120] Sterile preparations of clot foam were studied. The Neutral Half of PART A was sterile filtered in a biological safety cabinet using a Nalg-Nunc 500 mL device (Cat # 450-0045, nitrocellulose membrane, 0.45 m filter).

[0121] The basic PART A: BSA, MgCl<sub>2</sub> and CaCl<sub>2</sub> were dissolved in sterile water were added 0.15 g solution. The solution was sterile filter using 0.22 μm Millipore Syringe filter into above 8 mL of Neutral part. To this mixture then was added premeasured and autoclaved sterile 1.2 g of solid NaHCO<sub>3</sub> and 0.4 g of Carrageenan.

[0122] PART B: sodium monophosphate, tris(hydroxymethyl)aminomethane (TRIS-Base) and Activa were dissolved in sterile water. The solution was sterile filter using 0.22 μm Millipore Syringe filter. To this sterile mixture, 0.5 g UV sterile Carbomer was added

[0123] PART C: The acidic Fibrin Monomer was sterile filtered in a biological safety cabinet using a Nalg-Nunc 500 mL device (Cat # 450-0045, nitrocellulose membrane, 0.45 m filter).

[0124] PART D: ACTIVA dissolved in buffer solution was sterile filtered in a biological safety cabinet using a Nalg-Nunc 500 mL device (Cat # 450-0045, nitrocellulose membrane, 0.45 m filter).

[0125] Growth Study: The general experimental protocol included preparation of sample solutions which were then plated on Potato dextrose agar (PDA, Sigma-Aldrich, Cat#P2182) and Tryptic soy agar (TSA, Sigma-Aldrich, Cat# T4536) gels in Petri dishes for growth. The PDA and TSA gels were incubated and observed at the indicated periods of time for colony growth (mold and/or bacteria) at 37° C. and evaluated for colony growth using the naked eye at established time periods. Multiple samples are indicated with a 1, 2 and 3 designation in data tables.

Colony Count Key	
Symbol	Count
-	No visible growth
+	1-199 visible colonies
++	200-399 visible colonies
+++	>400 visible colonies

TABLE 2

Results of studies of microorganism growth analysis on PDA and TSA of the sterile components of FIBRIN\_ClotFoam.

Table 2. Sterilization Studies by Bacterial Growth on PDA/TSA at 37° C.

Time Elapsed (days)	Potato Dextrose Agar (PDA)							Tryptic Soy Agar (TSA)								
	1	2	3	4	5	6	7	11	1	2	3	4	5	6	7	11
Sample	#s <sup>S</sup>															
Neutral Half*	1			-			-	-				-			-	-
A**	1			-			-	-				-			-	-
	2			-			-	-				-			-	-
	3				+			-	-			-			-	-

TABLE 2-continued

Results of studies of microorganism growth analysis on PDA and TSA of the sterile components of FIBRIN_ClotFoam.																							
Table 2. Sterilization Studies by Bacterial Growth on PDA/TSA at 37° C.																							
Sample	Time Elapsed (days)	Potato Dextrose Agar (PDA)											Tryptic Soy Agar (TSA)										
		#s <sup>§</sup>	1	2	3	4	5	6	7	11	1	2	3	4	5	6	7	11					
B** <sup>^</sup>	1				-				!	-				-			-	-					
	2				-				-	-				-			-	-					
	3				-				-	-				-			-	-					
C** (Fibrin/AcOH, pH 3,5)	1				-				-	-				-			-	-					
	2				-				-	-				-			-	-					
	3				-			!	-	-				-			-	-					
Autoclaved NaHCO <sub>3</sub> <sup>+</sup>	1				-				-	-				-			-	-					
	2				-				-	-				-			-	-					
	3				-				-	-				-			-	-					
Autoclaved Carrageenan <sup>++</sup>	1				-				-	-				-			-	-					
	2				-				-	-				-			-	-					
	3				-				-	-				-			-	-					
Part D	1				-				-	-				-			-	-					
	2				-				-	-				-			-	-					
	3				-				-	-				-			-	-					

\*Neutral Half is sterile filtered using 0.45 µ filter, stored for a week at 4° C.

\*\*"sterile" A, B, C used for animal studies in SUNY, stored at 4° C. for a week

<sup>^</sup>add 1000 µL of sterile water only in A & B to make "liquid"

<sup>+</sup>Test Sterility of NaHCO<sub>3</sub> (used in A) after autoclaving at 121° C. for 20 min, make a saturated solution in sterile water

<sup>++</sup>Test Sterility of Carrageenan (used in A & B) after autoclaving at 121° C. for 20 min, make a solution in sterile water

<sup>§</sup>Experiments were performed in triplicates except for Neutral Half

! Experimental error

[0126] The growth data indicate that Neutral Half and other sterile components yielded no significant growth even after 11 days. Additional sterilization method with preservatives were tested at different concentration to inhibit growth. The growth data also indicate that after 3 days, methyl 4-hydroxybenzoate and Germaben II provide sterilization/inhibition of growth.

## CONCLUSION

[0127] Adopting a sterile preparation method inhibits growth of contaminants (mold and bacteria) and may provide an acceptable shelf-life of a commercial product. The addition of preservatives displayed inhibition of microbial growth.

### 6. Biocompatibility

[0128] Two ClotFoam preparations with and without Sodium Benzoate, prepared under sterile conditions-were tested. These preparations were tested for biocompatibility with human fibroblasts (HF) and human epithelial cells (A549 cell line, ATCC).

[0129] Normal human fibroblasts (HFs) were obtained from a commercial source and cultures established in 60 mm tissue culture plates in Dulbecco's modified Eagle's medium supplemented with 10% fetal bovine serum and maintained at 37° C. in a humidified 5% CO<sub>2</sub> atmosphere (CO<sub>2</sub> incubator). Human epithelial cell line A549 was maintained in Minimal Essential Medium supplemented with 10% fetal bovine serum and 2 mM glutamine. When fibroblast and epithelial cell cultures reached subconfluence, control and sodium benzoate ClotFoam preparations were mixed and immediately delivered into individual dishes. The cultures were returned to the CO<sub>2</sub> incubator and examined at day 0 (FIG. 9), at day 3 (FIG. 10) and at day 7 (FIG. 11). ClotFoam material and

medium was removed from all cultures, and adherent cells were stained with crystal violet (0.1% in 2% ethanol).

[0130] The main observation was a total absence of damage or toxicity to the cells, and absence of any bacterial or fungal contamination. In human fibroblast cultures exposed to ClotFoam preparations, the cells appeared slightly larger or more spread out than in control untreated cultures. Conclusion: ClotFoam and ClotFoam+preservative benzoate are biocompatible, and do not affect, but rather stimulate, the growth and differentiation of cells; which is an important attribute in wound healing agents.

### 7. Experiments in Animal Models

[0131] We conducted studies on several intracavitary trauma models on rats and swine (pig) models.

#### 7.1. Effect of ClotFoam on Blood Loss After Grade IV Liver Injury (Rat Models)

[0132] Methods: Ten male Sprague-Dawley rats (225-250 g) were used (approved by the Institutional Animal Care and Use Committee of UMB).

[0133] Experimental Procedure: A laparotomy was performed; Grade III liver injuries were induced in the larger left and right lobes. The injury was induced by clamping with a hemostatic clamp on both lobules and causing injury through the parenchyma of the liver of the two medial lobes.

[0134] After the first penetration of the liver, the clamp was opened and repositioned to the animal's left inducing the second lesion including more than 40% of distance from the border to the suprahepatic vena cava. After this repositioning, the liver was penetrated a second time. Further documentation of the liver injury was achieved by excision and inspection of the liver at the conclusion of the experiment. The injuries were through and through. No concomitant damage to the common

bile duct, caudal vena cava, or hepatic artery was noted. Ten animals received injuries for this study, and they were assigned randomly to receive either 4 ml of saline solution (Control) or 4 ml of ClotFoam agent. Immediately after the injury was induced, ClotFoam or saline was administered through a needle into the peritoneal cavity.

**[0135]** The bleeding time was observed and recorded. Then the abdominal cavity was closed with 4-0 nylon to observe the animals for 90 minutes. After this period of time the animal was re-anesthetized and all the fluids in the abdominal cavity were collected in a pre weighted gauze and re weighted to measure the intraperitoneal volume and calculate blood losses.

**[0136]** Results: Bleeding time in control group showed a mean of 37 seconds ( $\pm$ SD 7.5). In the CLOTFOAM treated group bleeding in injured areas stops areas with 4 seconds (+1.0). This difference showed statistical significance with  $p < 0.008$ .

**[0137]** Blood loss measurements in the control untreated group were 2.45 mL (from 1.86-3.61) with a SD of 0.67 in the control group in contrast the treated group had a mean of 0.95 mL (0.72-1.78) with a SD of 0.55, T-test showed this difference to be statistically significant with a p value of 0.028

#### 7.2. Validation of Sealing Efficacy of ClotFoam in Liver Damage (Rat Models)

**[0138]** Livers were removed for observation of the lesions and clot forming behavior. It was found that in controls (FIG. 12) the damaged areas develop some clots on them but invariably they remain separated. In contrast, when the ClotFoam is administered, livers show the formation of very strong clots in the injured areas (FIG. 13), with no adherence of the clot to the undamaged tissue.

#### 7.3. Aortic Model in Laparotomy Experiments

**[0139]** Methods: In this model, a midline laparotomy is made. The aorta is clamped just below the renal arteries and just above the bifurcation of the iliac arteries, effectively gaining infrarenal proximal and distal aortic control. The infrarenal aorta is then pierced with a 25 gauge needle once on both left and right sides of the vessel. After 6 seconds of uncontrolled bleeding, 500 microliters of ClotFoam is applied diffusely throughout the intraperitoneal cavity. After completion of foam application, time to hemostasis is measured. The abdomen is then closed.

**[0140]** Immediately after injury, the rat is given Ringer's solution to maintain mean arterial pressure at about 70-80% of initial MAP (if possible) which is the current standard resuscitation technique for trauma patients. The rat is observed for 20 minutes. After 20 minutes, the animal is re-explored through the same midline incision. All of the blood is collected with pre-weighed gauze pads and total blood loss is calculated

**[0141]** Results: Seventeen animals underwent aortic injury. Animals were randomized into 2 different groups: treated and non-treated with ClotFoam. Survival was 100% at 60 minutes for all animals treated with ClotFoam. No animals survived the injury in the no treatment group. All pre-injury MAP were similar. Table 1 below summarizes the outcomes measured in each group.

TABLE 3

Comparison of outcomes for aortic-injured animals treated with ClotFoam versus no treatment. Resuscitation index is defined as the resuscitation MAP percentage of pre-injury MAP. P values for all outcomes and all formulations are $< 0.001$ compared to no agent.		
Outcome	Form #10 (N = 10)	No agent (N = 7)
Time to hemostasis (s)	12.2 $\pm$ 2.9	N/A
Total blood loss (ml)	5.2 $\pm$ 0.5	16.3 $\pm$ 0.3
Resuscitation index (%)	68.8 $\pm$ 14.0	26.8 $\pm$ 2.4
Resuscitation volume (ml)	12 $\pm$ 4.5	20.3 $\pm$ 2.5
Survival (min)	60 $\pm$ 0	18..3 $\pm$ 2.9

#### 7.4. Cava Vein Model

**[0142]** The second model is a liver/vena caval injury model. In this model, a small upper midline laparotomy is made. The left lobe of the liver and the vena cava are exposed and isolated. A small incision is created in the right lower quadrant and the ClotFoam applicator tip is placed through that incision so that the opening is intraperitoneal but remote from where the injury will take place. Next the injury is created by sharply transected the left liver lobe and then creating a stab injury into the vena cava. The mini-laparotomy incision is rapidly closed with staples. ClotFoam is then injected into the closed abdominal cavity. Resuscitation, observation and blood loss measurements are collected as mentioned above.

**[0143]** Twelve animals underwent liver/vena cava vein injuries. Animals were randomized into different two groups: treated and untreated with ClotFoam. Survival was 100% at 60 minutes for all animals treated with ClotFoam.

**[0144]** The applicator was placed into the intraperitoneal cavity. At the 20 minute mark after liver/caval injury, the animal was opened fully to expose the injured area.

**[0145]** The animals in the no treatment group died at  $> 18$  minutes from injury. All pre-injury MAP were similar. Table 4 summarizes the outcomes measured in each group.

TABLE 4

Outcome	Form 10 (N = 7)	No agent (N = 5)
Total blood loss (ml)	3.6	14.7
Resuscitation index (%)	88.6	54.3
Resuscitation volume (ml)	10	16
Survival (min)	30	18

TABLE 5

Model	10		NS (ml)	10 min	2 hrs	TTH	Survival
	baseline	sec					
Aortic	151/110 (120)	38/31 (34)	4.0	133/124 (110)	131/117 (124)	3 m	all
Cava vein	140/105 (115)	63/34 (41)	3.5	109/69 (83)	130/72 (97)	2 m	all
Liver injury	162/102 (128)	66/41 (50)	4.2	131/69 (87)	135/87 (102)	2 m	all

TABLE 5-continued

Model	baseline	10 sec	NS (ml)	10 min	2 hrs	TTH	Survival
Control cava vein	150/112 (128)	50/37 (41)	9.7	75/38 (48)	NA	NA	none
Control aortic	153/108 (119)	42/34 (33)	10.5	N/A	N?A	N/A	none

7.5 Summary of ClotFoam effects in three different hemorrhagic models: Data in table 5 compares results obtained with the different models. Control represents puncture model with NS treatment alone. Numbers represent blood pressure and mean arterial pressure (MAP—in parenthesis) at baseline 10 seconds, 10 minutes and two hours post insult. NS—normal saline administration in ml. NA—not applicable (control animals died before 2 end point). TTH—total time to hemostasis, measured as function of a sustained and maintained rise in blood pressure and MAP of 70.

7.6. Non-GLP Studies in Pigs

**[0146]** ClotFoam was evaluated in the pig model. Methods: Eighteen female Yorkshire crossbred swine, age 2.5 months, weighing 37±2 kg, were used. The protocol was approved by the Institutional Animal Care and Use Committee. Animals then underwent either grade 4 liver injuries via open laparotomy or by laparoscopy. For the purposes of this model, a grade IV injury was a 10 cm deep parenchymal injury with a specially designed high-speed drill with a cutting drill bit creating an injury akin to a penetrating gunshot (GSW) (FIG. 14). These injuries were consistent with the American Association for the Surgery of Trauma Organ Injury Scaling system. After the liver was exposed, a spot in the middle of the liver was selected to produce the liver injury. The position was calculated by approximation to the suprahepatic vessels and some branches of the portal vein. The spot was marked with a marker. After the damage was induced, surgeons close the cavity, allowed for 30 seconds of massive bleeding before applying ClotFoam through a small perforation.

**[0147]** Animals were randomized into 4 groups to date. Group 1 (n=5) consisted of animals who underwent grade IV liver injuries through an open midline laparotomy and had open cavity ClotFoam application. In this group the agent was visually directed to the liver injury. Group 2 (n=6) consisted of animals who underwent grade IV liver injuries produced by a drill through a laparoscopic procedure and had closed cavity ClotFoam application. In this group the agent was administered into the peritoneal cavity blindly without direct injury visualization or direction. Group 3 (n=4) consisted of animals underwent grade 4 liver injuries through an open midline laparotomy without ClotFoam treatment (open controls). Group 4 (n=3) underwent grade 4 liver injuries through the laparoscopic technique without ClotFoam treatment (laparoscopic controls).

**[0148]** In all groups, 150 cc of ClotFoam was used for treatment. The ClotFoam was delivered via a mixing device into the abdominal cavity (FIG. 15). Fluid resuscitation with Lactated Ringer's (LR) was begun immediately after injury. LR was infused as necessary to re-establish a MAP within at least 80% of the pre-injury MAP if possible. Resuscitation was continued for the

entire observation period. At the end of the 60 minute study, each animal's MAP and the total resuscitation volume infused were recorded.

**[0149]** After completion of the study period, the abdomen was examined (FIG. 16). Liquid blood was suctioned. Blood clots were removed and weighed. In the gauze packing group, additional liquid blood loss was calculated by subtracting the wet gauze weight from dry gauze weight (FIG. 17). Total blood loss was determined by adding liquid and clotted blood losses.

**[0150]** Animal survival was defined as the presence of a heart rate at the end of the study period. At 60 minutes, surviving animals were euthanized with 10 ml of Euthasol.

**[0151]** Results: End points for animals in Groups 1 and 2 (Grade IV injuries) are shown in Table 6. Trend of mean arterial pressures (MAPs) are seen in FIG. 18 (treated).

TABLE 6

Outcome measures for Grade IV liver injuries treated with ClotFoam. Group 1 = open cavity, Group 2 = closed cavity. All values reported as mean ± SEM

Group	Survival Time (min)	Total Blood Loss (ml)	Fluid Requirement (ml)
1 (n = 5)	60 ± 0	300 ± 283	1500 ± 283
2 (n = 5)	60 ± 0	600 ± 212	2175 ± 742

**[0152]** Controls: Animals underwent grade IV liver injuries (3 laparoscopic and 4 open) to validate the laparoscopic model against the established open model. These animals were not treated with ClotFoam. Endpoints are seen in Table 7.

TABLE 7

Outcome measures for Grade IV liver injuries without treatment (Controls). Group 3 = open laparotomy, Group 2 = laparoscopic. All values reported as mean ± SEM

Group	Survival Time (min)	Total Blood Loss (ml)	Fluid Requirement (ml)
3 (n = 4)	26 ± 3	1900 ± 424	3050 ± 70
4 (n = 4)	22 ± 11	1700 ± 200	2467 ± 569

**[0153]** Trend of MAPs for Grade 4 liver injuries of controls untreated with ClotFoam are shown in FIG. 19

Clot Histology

**[0154]** Liver section samples were collected from all animals at necropsy. Samples of liver, containing the wounded site, were preserved in 5% formalin and processed using standard histology techniques. Fixed tissue samples were embedded in paraffin wax (melting point 56° C.) and sectioned at 2-3 µm. Glass-slide-mounted sections were then stained with hematoxylin and eosin (H&E). Two liver sections perpendicular to the resection site were evaluated per animal.

8. GLP Studies in the Swine

**[0155]** Effectiveness: We compared the effectiveness of ClotFoam hemostatic treatment without compression in

Yorkshire crossbred swine, age 2.5 months, weighing 37±2 kg. We tested Clot foam in three surgical protocols: Hepatectomy, Partial via open midline laparotomy, assigning 20 animals to the protocol. The protocols were approved by the Institutional Animal Care and Use Committee. Animals were randomized into 2 groups. Group 1 (n=14) consisted of animals that received ClotFoam application following injury. Group 2 (n=6) consisted of animals that received GELFOAM (Pfizer) following injury versus GelFoam (Pfizer) to stop moderate to severe bleeding. The studies were designed to determine whether the hemostatic can control intraoperative hemorrhage within 10 minutes of application.

apex of the kidney was sharply divided and removed, and permitted to bleed for 10 seconds. ClotFoam will be applied and hemostasis was assessed at 5 minutes.

**[0159]** Spleen laceration: A 3×3 cm square laceration was created and removed from the anterior surface of the spleen and permitted to bleed for 10 seconds. ClotFoam was applied, and hemostasis was evaluated at 5 minutes.

Results:

**[0160]**

Number of animals that reached hemostasis per procedure

Group	N	Procedure	Number of animals reaching Hemostasis within 5 minutes	Termination at day 15	Necropsy	Histology	IgE
1(GF)	6	Hepatectomy	None	None	None	None	6 (control)
2 (CF)	14	Hepatectomy	14	14	14	14	14
3 (GF)	6	Nephrectomy	None	none	None	None	None
4 (CF)	14	Nephrectomy	12	11	No	11	11
5 (GF)	6	Spleen	13	8	8	8	8
6 (GF)	14	Spleen	None	None	None	None	None

Acronyms:  
GF = GelFoam;  
CF = ClotFoam

**[0156]** Surgical procedures: We tested Clot foam in three surgical protocols: Hepatectomy, Partial nephrectomy and Spleen laceration via open midline laparotomy, assigning 20 animals to each protocol, or a total of 60 animals. The protocols were approved by the Institutional Animal Care and Use Committee. Animals were randomized into two arms. Group 1 (n=14) consisted of animals that received ClotFoam application following injury. Group 2 (n=6) consisted of animals that received GELFOAM (Pfizer) following injury to stop moderate to severe bleeding. Animal numbers were determined by using a power analysis set to the standard of 0.8. The studies were designed to determine whether the hemostatics can control intraoperative hemorrhage without compression within 5 minutes of application. Ability to achieve hemostasis within 5 minutes of application without compression and with no re-bleeding within 10 minutes demonstrated the therapeutic benefit of the hemostatic sealant. Once the hemostasis was assessed, the abdominal incision was closed. Animals that did not reach hemostasis within 10 minutes were euthanized. Upon termination of experiments at 14 or 15 days, surviving animals were euthanized, surgical areas inspected, and tissue recovered for macroscopic and microscopic examinations

**[0157]** Hepatectomy model: A partial right hepatectomy was performed in which the distal 4 cm right lobe of the liver was sharply divided and removed. Bleeding was permitted for 10 seconds. 40CC of ClotFoam was applied, and hemostasis was assessed at 5 minutes.

**[0158]** Partial nephrectomy: The kidney was completely immobilized from the retroperitoneum. The distal 3 cm of the

**[0161]** Immune response: There were no significant differences in OD readings observed with sera collected on day 0, day 7 or day 14 from control and ClotFoam treated pigs when tested against gelatin or BSA. We conclude that experimental pigs produced no detectable antibodies against gelatin or BSA at the times tested.

Biomptatibility and Biodegradation (Histology)

**[0162]** Most organs have normal appearance ClotFoam treated animals as compared from samples taken from a sham specimen. Abnormalities were noted in lungs of all animals (lymphocytic infiltration). Inflammatory changes and lymphocytic infiltration was seen in gut tissues

**[0163]** and in the abdominal wall. The inflammatory changes appear due to the internal trauma and to a normal inflammatory reaction to a foreign body (ClotFoam).

**[0164]** Conclusion: The data from this study indicates that ClotFoam was 100% successful in achieving intraoperative hemostasis for a liver wound that produced severe hemorrhage. Since hemostasis was achieved within 5 minutes, we conclude that the use of ClotFoam requires shorter time to achieve hemostasis than conventional suturing methods utilized in laparoscopic procedures

What is claimed is:

1. A four-part composition of a hydrogel carrier for a fibrin sealant (fibrin monomer) to be used as a non-compressible haemostatic agent for the control of bleeding and prevention of haematoma formation.

2. The composition set forth in claim 1 that can stop bleeding in cases of severe hemorrhage and seal lacerated tissue without the need of sutures, stitches, or other elements of compression.

3. A four-part hemostatic composition including a hydrogel carrier and a fibrin monomer, in combination, for cessation of blood loss from injured tissue of a patient's body without application of a compressive force independently therefrom, the composition comprising: a first component (Part A), in a liquid form, of Teleostean (fish) gelatin type A mixed with sucrose, polyvinylpyrrolidone, and Bovine serum albumin in a selected buffer solution at a pH of about 8.3 in the presence of metallic ions; a second component (Part B) of a selected, relatively high molecular weight acrylic acid of carbomer and divalent ions in a pH 3.4 solution; a third component (Part C) of a fibrin monomer in a selected acidic solution that polymerizes upon change in pH; and a fourth component (Part D) having a selected calcium independent transglutaminase enzyme and calcium chloride for stabilizing the fibrin polymer.

4. The composition set forth in claim 3, wherein the alkaline buffer in solution has a concentration generally within a range of 0.5M and 0.75M sodium carbonate/bicarbonate.

5. The composition set forth in claim 3, wherein Part D comprises a source of calcium ions in a concentration of about 20 mM solution suitable for polymerization of the fibrin monomer.

6. The composition set forth in claim 3, wherein the divalent ions include calcium, zinc and magnesium ions for substantially increasing the rate of fibrin polymerization, the length and strength of fibrin filaments, and fastening scaffold polymerization.

7. The composition set forth in claim 3, wherein Parts A-D retain their physical and chemical properties during sterilization.

8. The composition set forth in claim 3, wherein the fibrin monomer concentration is generally within a range of 12 mg/ml and 20 mg/ml of acetic acid.

9. The composition set forth in claim 3, wherein Parts A-D and the composition are bio-compatible with tissue on which they are applied.

10. The composition set forth in claim 3, wherein the blood loss is a result of hematoma formation during a selected procedure or event of the patient that results in blood loss including, but not limited to, internal trauma, general surgery, laparoscopic procedure(s) and liposuction.

11. The composition set forth in claim 3, wherein the polyvinylpyrrolidone, sucrose, albumin and gelatin are macromolecules which, upon mixture, produce a 3-D polymer that enhances the longevity and quality of the foam, while improving tissue adhesivity through matrix formation.

12. The composition set forth in claim 3, wherein the fibrin monomer is a non-dynamic fibrin monomer that is substantially free of thrombin and any exogenous enzymes which catalyze the formation of fibrin from fibrinogen.

13. A method of sealing injured tissue of a patient's body that utilizes a four-part hemostatic composition including a hydrogel carrier and a fibrin monomer, in combination, for cessation of blood loss from the injured tissue without application of a compressive force independently therefrom, the method comprising the steps of:

- (i) mixing a first component (Part A), in a liquid form, of Teleostean (fish) gelatin type A mixed with sucrose, polyvinylpyrrolidone, and Bovine serum albumin in a

selected buffer solution at a pH of about 8.3 in the presence of metallic ions, with a second component (Part B) of a selected, relatively high molecular weight acrylic acid of carbomer and divalent ions in a pH 3.4 solution, in a selected mixing device;

- (ii) mixing the mixture of step (i) with a third component (Part C) of a fibrin monomer in a selected acidic solution that polymerizes upon change in pH, in the mixing device;

- (iii) mixing the mixture of step (ii) with a fourth component (Part D) having a selected calcium independent transglutaminase enzyme and calcium chloride for stabilizing the fibrin polymer, in the mixing device so as to create a foam;

- (iv) delivering and/or dispersing the foam through an outlet of the mixing device to a surgical site of a body cavity, organ or tissue so as to place the foam in contact with the site such that the non-dynamic, non-crosslinked fibrin monomer of the foam sticks to wet tissue of the site and forms a matrix in the patient's blood; and

- (v) rendering the non-crosslinked fibrin monomer dynamic by neutralizing its pH such that the non-crosslinked fibrin is converted to a fibrin sealant, thereby inducing coagulation of the blood and adhesive properties of severed tissue.

14. The method set forth in claim 13, wherein the surgical site includes the patient's skin, abdominal cavity, thorax, cardiovascular system, lymphatic system, pulmonary system, ear(s), nose, throat, eye(s), liver, spleen, cranial, spinal, maxillo-facial, bone, tendon, pancreas, genito-urinary tract or alimentary tract.

15. The method set forth in claim 13, further comprising the steps of mixing the water-solubilized components of the four-part composition adhesive, and then polymerizing/crosslinking the adhesive by a selected polymerizing/crosslinking reaction effected by a mixing device.

16. The method set forth in claim 13, wherein the mixing device of steps (i)-(iii) is a pneumatically operated, four-barreled syringe, each barrel containing one of component Parts A, B, C and D.

17. The method set forth in claim 13, wherein the cross-linked matrix formed by Teleostean (fish) gelatin type A, Bovine serum albumin, carrageenan (sulfonated polysaccharide) polyvinylpyrrolidone, sucrose, carbomer 934 and ACTIVA in buffer solution serves as scaffold for the fibrin components to bind tissue together without compression independently therefrom or the addition of a suture, a staple, a tape, or a bandage.

18. The method set forth in claim 13, further comprising the step of dispersing the mixture of Parts A, B, C and D, upon its formation into an adhesive foaming hydrogel, into the patient's body cavity such that the mixture minimizes blood loss from the injured tissue for a selected period of time as is suitable to form a fibrin clot and, thereby, seal the wound.

19. The method set forth in claim 18, wherein the adhesive foaming hydrogel is formed in less than about 10 seconds of mixing component Parts A, B, C and D.

20. The method set forth in claim 18, wherein the adhesive foaming hydrogel formed attains a storage moduli ( $G'$ ) of about 6000 dyn/cm<sup>2</sup> monitored by rheometry as a function of time at a frequency of around 5 Hz and a about 2% stress strain at approximately 37° C.

21. The method set forth in claim 13, wherein in step (ii) the solution of component Part C includes a fibrin monomer dissolved in acetic acid.

22. The method set forth in claim 13, wherein step (iii) further comprises the step of maintaining the fibrin monomer, polymerized and stabilized, in the four-part solution so as to form a fibrin sealant.

23. The method set forth in claim 13, wherein polymerization of the fibrin monomer is effected by the acid solution upon the addition of alkaline Part A to the fibrin monomer.

24. The method set forth in claim 13, wherein step (iii) further comprises the step of maintaining the fibrin polymer, as stabilized through activity of the transglutaminase enzyme in Part D, for over 90 days.

25. The method set forth in claim 13, wherein foam formation is induced by a chemical reaction of carbomer 934 and sodium monobasic phosphate ( $\text{NaH}_2\text{PO}_4$ ) in mixture with a simple buffer solution of sodium bicarbonate ( $\text{NaHCO}_3$ ) such that carbon dioxide ( $\text{CO}_2$ ) is released in the presence of divalent ions or surfactants.

26. The method set forth in claim 13, wherein the foam produced upon mixing of component Parts A, B, C and D is a

non-exothermic foam having a volume about 400% greater than that of the component Parts before mixing step (i).

27. A medical kit for preparation and application of a four-part hemostatic composition including a hydrogel carrier and a fibrin monomer, in combination, for cessation of blood loss from injured tissue of a patient's body without application of a compressive force independently therefrom, the kit comprising: a first component (Part A), in a liquid form, of Teleostean (fish) gelatin type A mixed with sucrose, polyvinylpyrrolidone, and Bovine serum albumin in a selected buffer solution at a pH of about 8.3 in the presence of metallic ions; a second component (Part B) of a selected, relatively high molecular weight acrylic acid of carbomer and divalent ions in a pH 3.4 solution; a third component (Part C) of a fibrin monomer in a selected acidic solution that polymerizes upon change in pH; a fourth component (Part D) having a selected calcium independent transglutaminase enzyme and calcium chloride for stabilizing the fibrin polymer; and a device for mixing, delivering and/or dispersing the composition, upon mixing, through an outlet of the mixing device to a site at the patient's body.

\* \* \* \* \*

专利名称(译)	用于不可压缩性出血的组织密封剂		
公开(公告)号	<a href="#">US20110066182A1</a>	公开(公告)日	2011-03-17
申请号	US12/750316	申请日	2010-03-30
[标]申请(专利权)人(译)	BIOMEDICA管理		
申请(专利权)人(译)	该管理公司		
当前申请(专利权)人(译)	该管理公司		
[标]发明人	FALUS GEORGE		
发明人	FALUS, GEORGE		
IPC分类号	A61K9/00 A61K38/45 A61P17/02 A61P43/00 A61B17/03		
CPC分类号	A61B17/00491 A61L24/0031 A61L24/043 A61L24/106 A61L2400/04 C08L89/06 A61P17/02		
其他公开文献	US8314211		
外部链接	<a href="#">Espacenet</a> <a href="#">USPTO</a>		

摘要(译)

ClotFoam是一种外科密封剂和止血剂，设计用于不可压缩性出血的病例。它可以通过腹腔镜端口应用于手术室，或者通过腹腔，胸腔，四肢或其他腔内严重创伤后通过混合针和/或喷雾注射方法直接在剖腹手术中或手术室外的撕裂组织上施用以促进止血。其交联技术产生粘合的三维聚合物网络或支架，其携带止血所需的纤维蛋白密封剂。当混合时，Clotfoam产生的泡沫遍布体腔，到达撕裂的组织，以密封组织并促进凝血级联。泡沫的粘弹性附着性质以及纤维蛋白凝块的快速形成，其确保密封剂保持在施用部位而不被血液冲走或被靶组织的运动所抵消。

