



US010433926B2

(12) **United States Patent**
Recanati et al.

(10) **Patent No.: US 10,433,926 B2**
(45) **Date of Patent: Oct. 8, 2019**

(54) **CABLE, WIRE AND TUBE ORGANIZER FOR LAPAROSCOPIC AND HYSTEROSCOPIC SURGERY**

(71) Applicants: **Maurice-Andre Recanati**, New York, NY (US); **Mohammad Ali E. Ozbeki**, Novi, MI (US); **Katherine J. Kramer**, Philadelphia, PA (US); **Sejal Tamakuwala**, New Windsor, NY (US)

(72) Inventors: **Maurice-Andre Recanati**, New York, NY (US); **Mohammad Ali E. Ozbeki**, Novi, MI (US); **Katherine J. Kramer**, Philadelphia, PA (US); **Sejal Tamakuwala**, New Windsor, NY (US)

(*) Notice: Subject to any disclaimer, the term of this patent is extended or adjusted under 35 U.S.C. 154(b) by 0 days.

(21) Appl. No.: **15/893,806**

(22) Filed: **Feb. 12, 2018**

(65) **Prior Publication Data**

US 2018/0228564 A1 Aug. 16, 2018

Related U.S. Application Data

(60) Provisional application No. 62/457,206, filed on Feb. 10, 2017.

(51) **Int. Cl.**

A61B 50/20 (2016.01)
F16L 3/223 (2006.01)
F16L 3/10 (2006.01)

(52) **U.S. Cl.**

CPC **A61B 50/20** (2016.02); **F16L 3/1075** (2013.01); **F16L 3/2235** (2013.01)

(58) **Field of Classification Search**

CPC A61B 50/20; F16L 3/1075; F16L 3/2235
USPC 249/68.1; 248/68.1, 69, 58, 62, 63
See application file for complete search history.

(56) **References Cited**

U.S. PATENT DOCUMENTS

4,579,310 A	4/1986	Wells et al.	
4,660,790 A *	4/1987	Muz	F16L 3/2235 174/156
4,775,121 A *	10/1988	Carty	F16L 3/2235 24/543
4,881,705 A *	11/1989	Kraus	F16L 3/08 248/68.1
5,060,810 A *	10/1991	Jones	A47F 7/0035 211/4
5,224,674 A	7/1993	Simons	
5,240,224 A *	8/1993	Adams	B28B 23/005 249/219.1

(Continued)

FOREIGN PATENT DOCUMENTS

WO 2011097072 A1 8/2011

Primary Examiner — Kimberly T Wood

(74) *Attorney, Agent, or Firm* — Jacob M. Ward; Ward Law Office LLC

(57) **ABSTRACT**

An organizing device for use during medical procedures is disclosed which, when used during laparoscopic or hysteroscopic surgery, enables the surgeon to keep multiple tubes, wires and cables organized. In a first embodiment, this device may have a rectangular shaped body, a top section with an integral ring at its center and a bottom section having a plurality of slots optimized for the insertion and retention of cables and tubes. The end sections contain, on one end a second integral ring, and on another a pivot point allowing a friction-closure latch mechanism to secure the slots. In a second embodiment, the device may have a donut shaped body, an integral ring at the center and a plurality of slots radially arranged at the periphery and secured through a cylindrical latching mechanism.

12 Claims, 12 Drawing Sheets

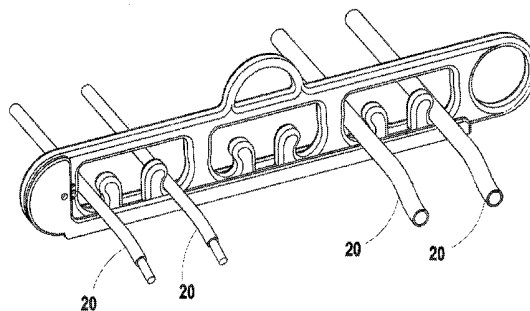
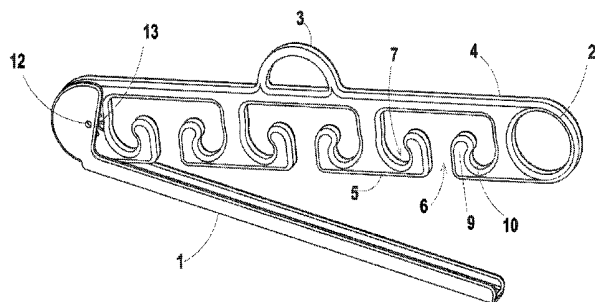

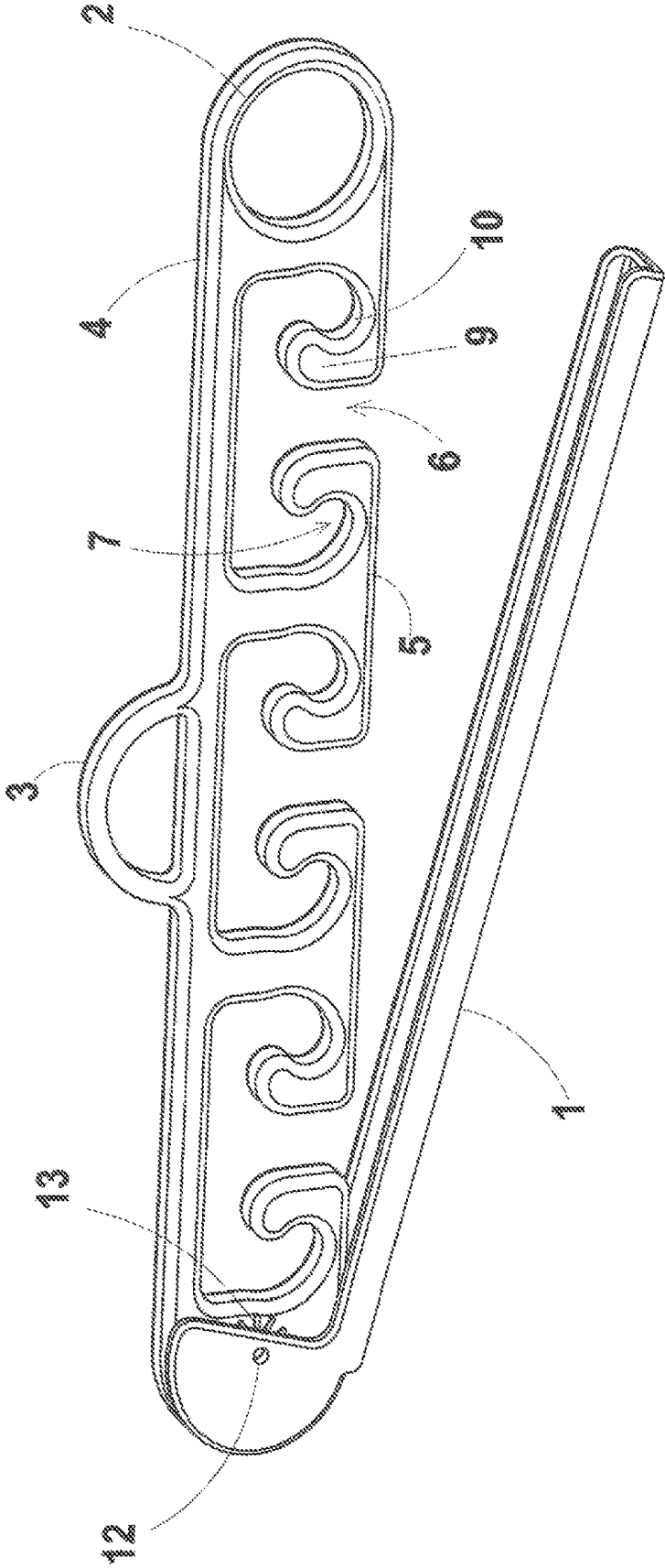

FIG. 1

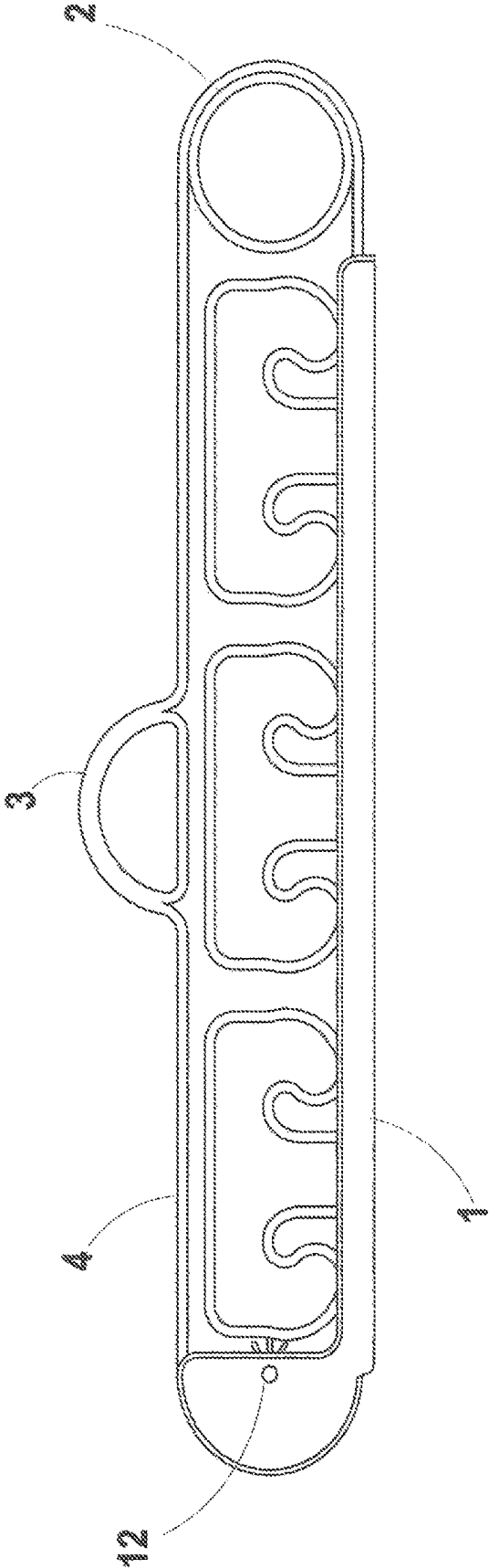

FIG. 2

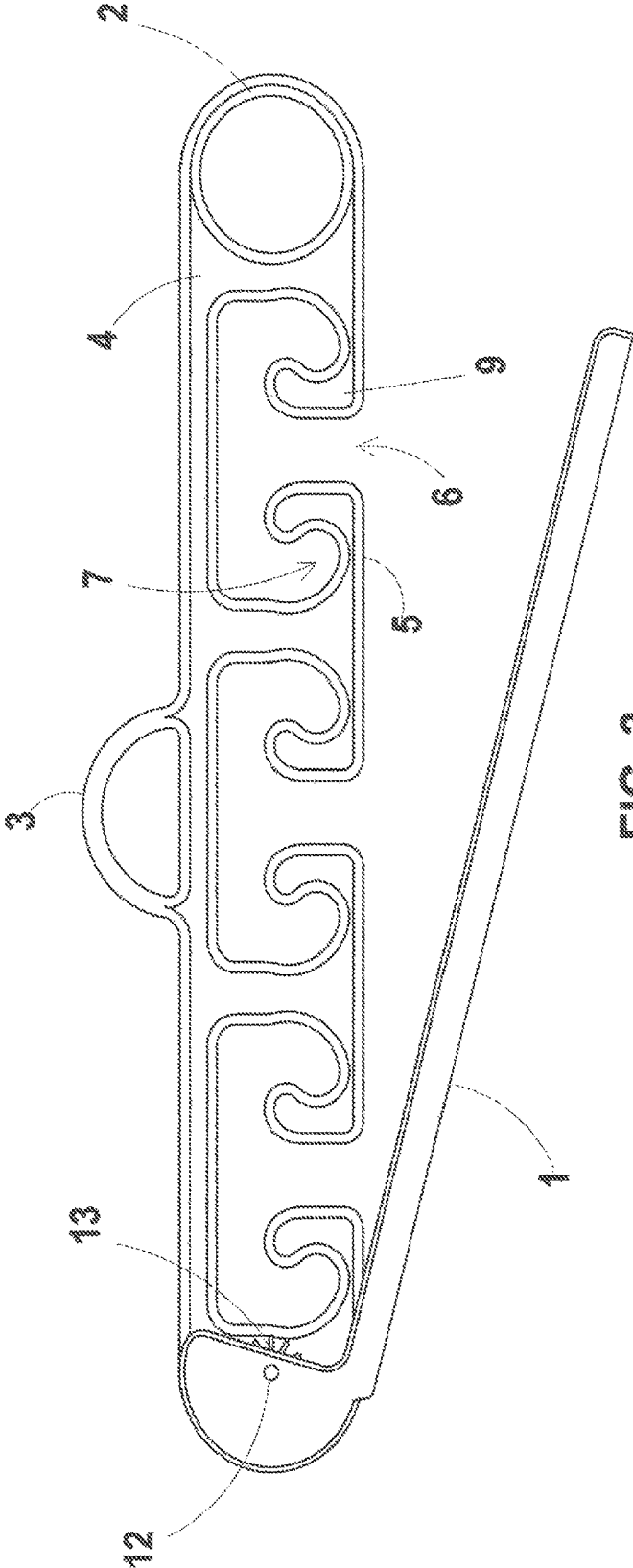

FIG. 3

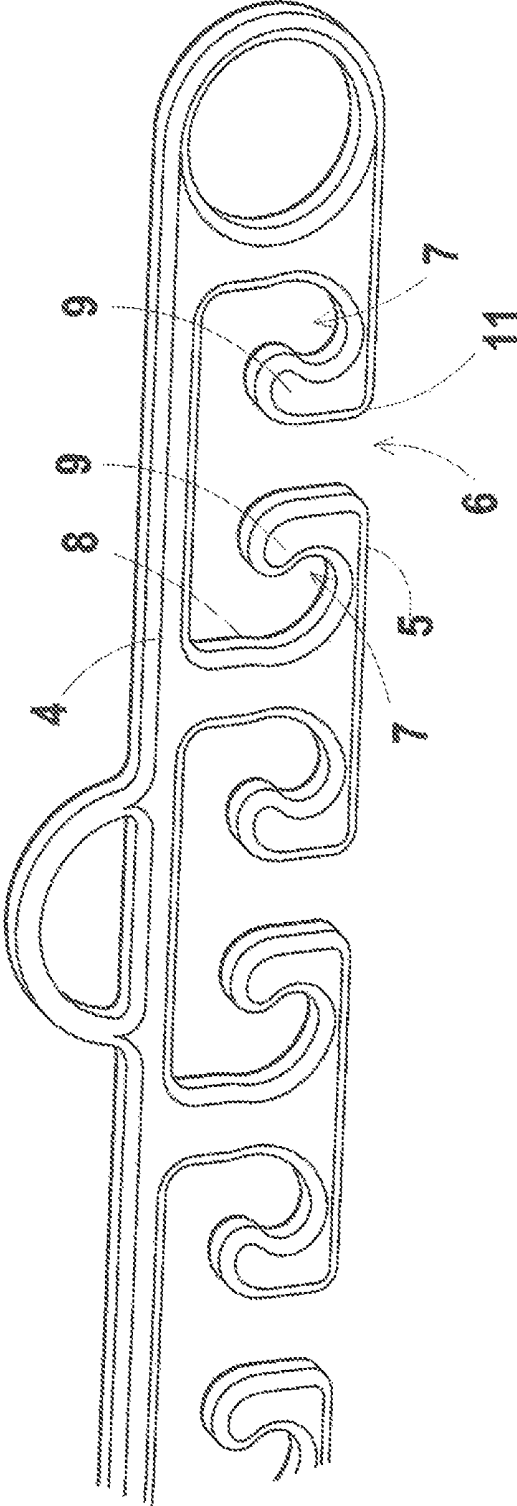

FIG. 4

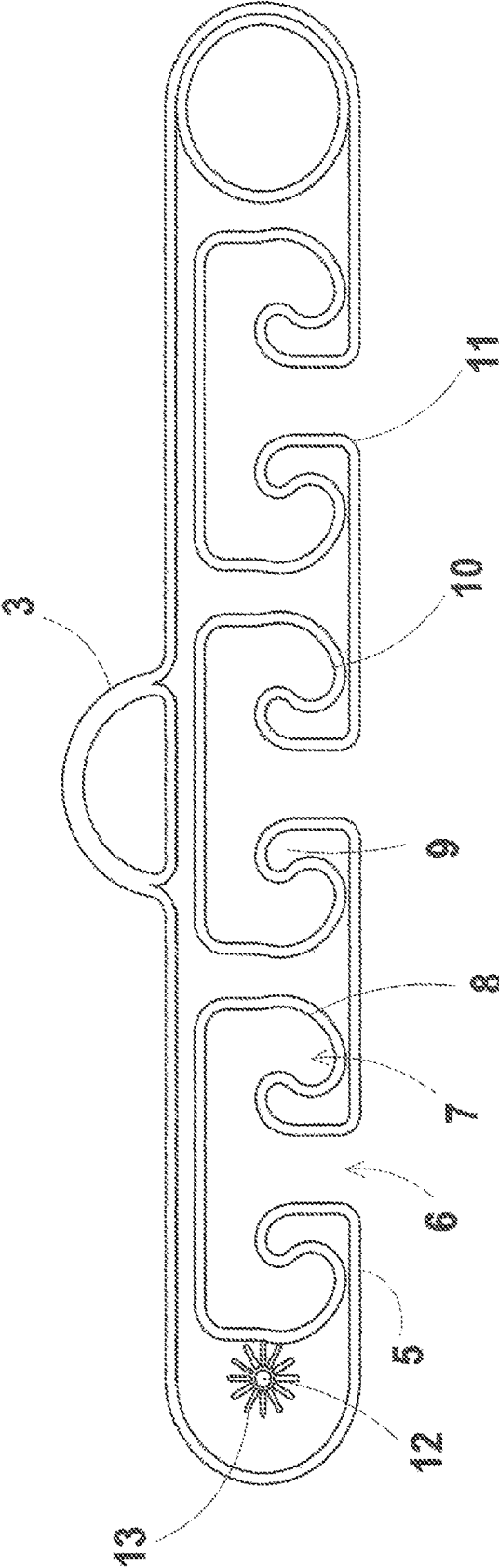

FIG. 5

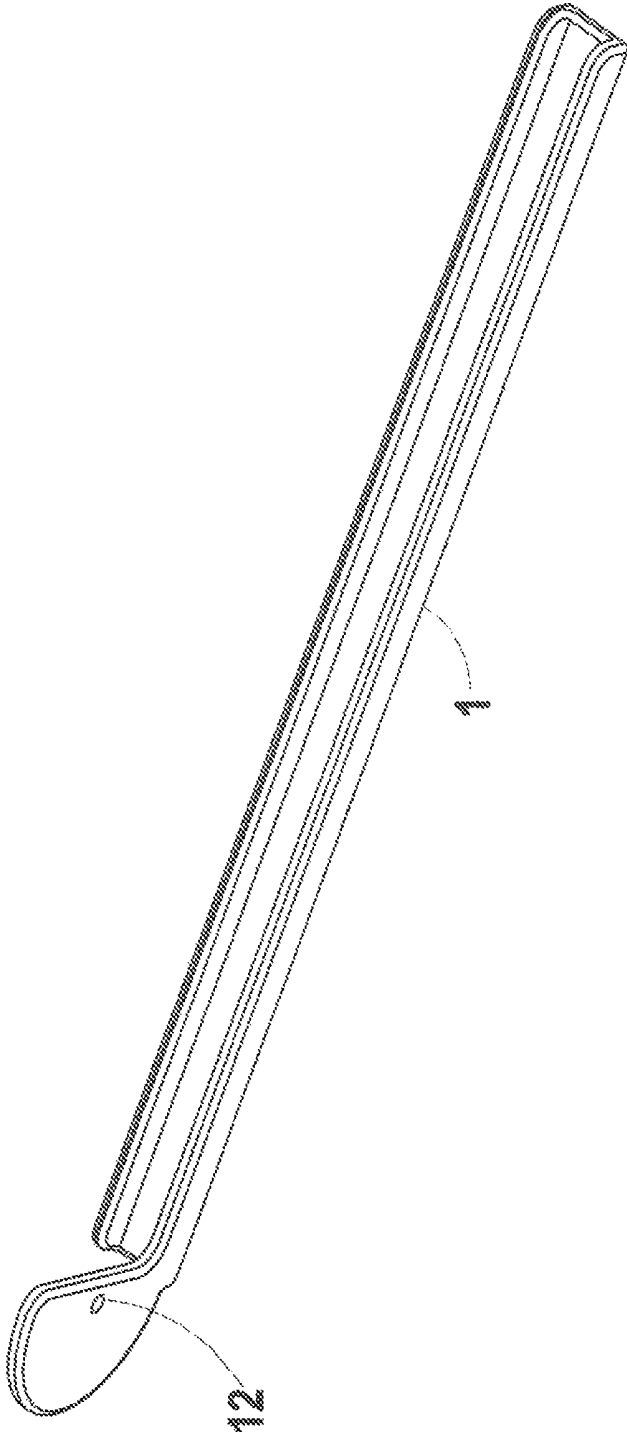

FIG. 6

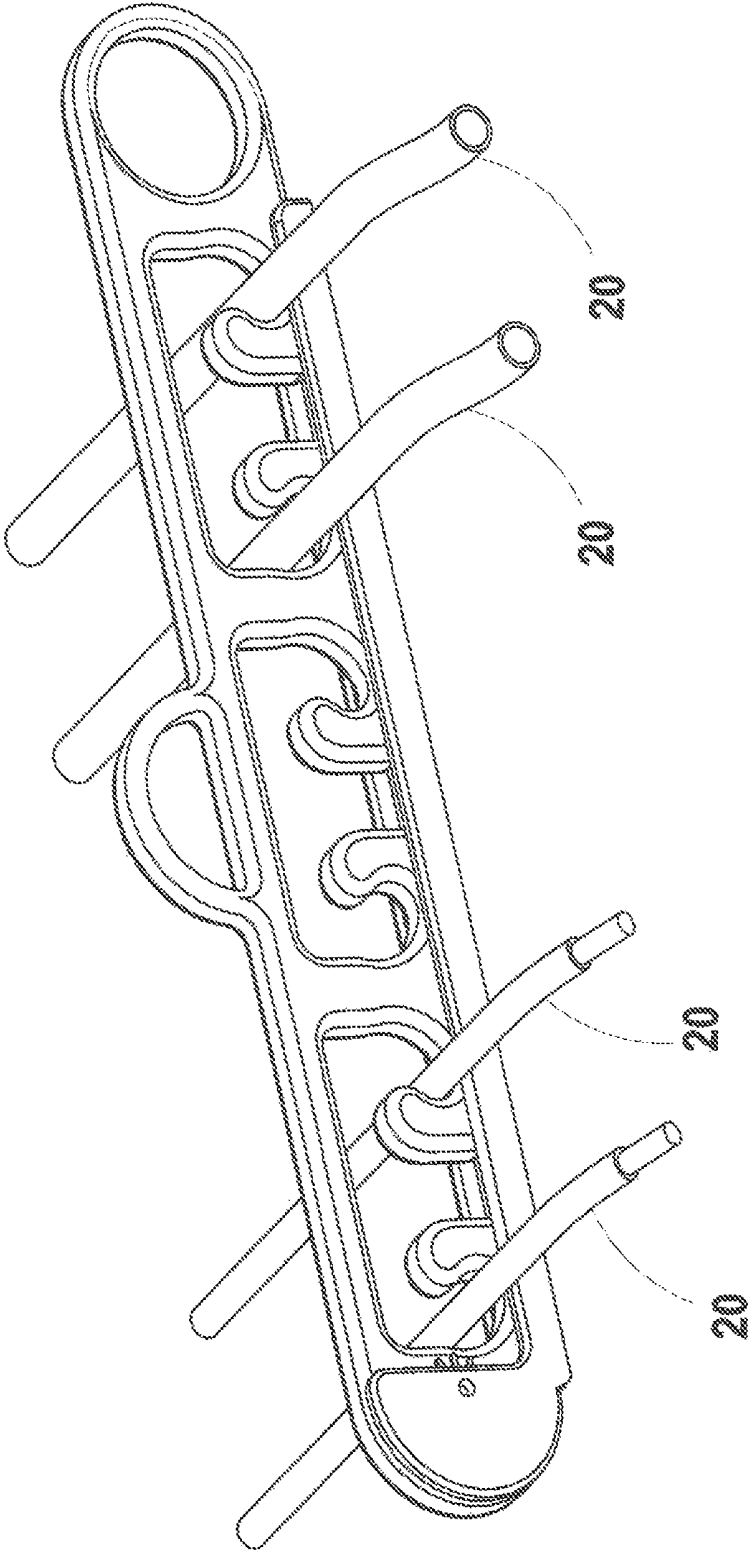

FIG. 7

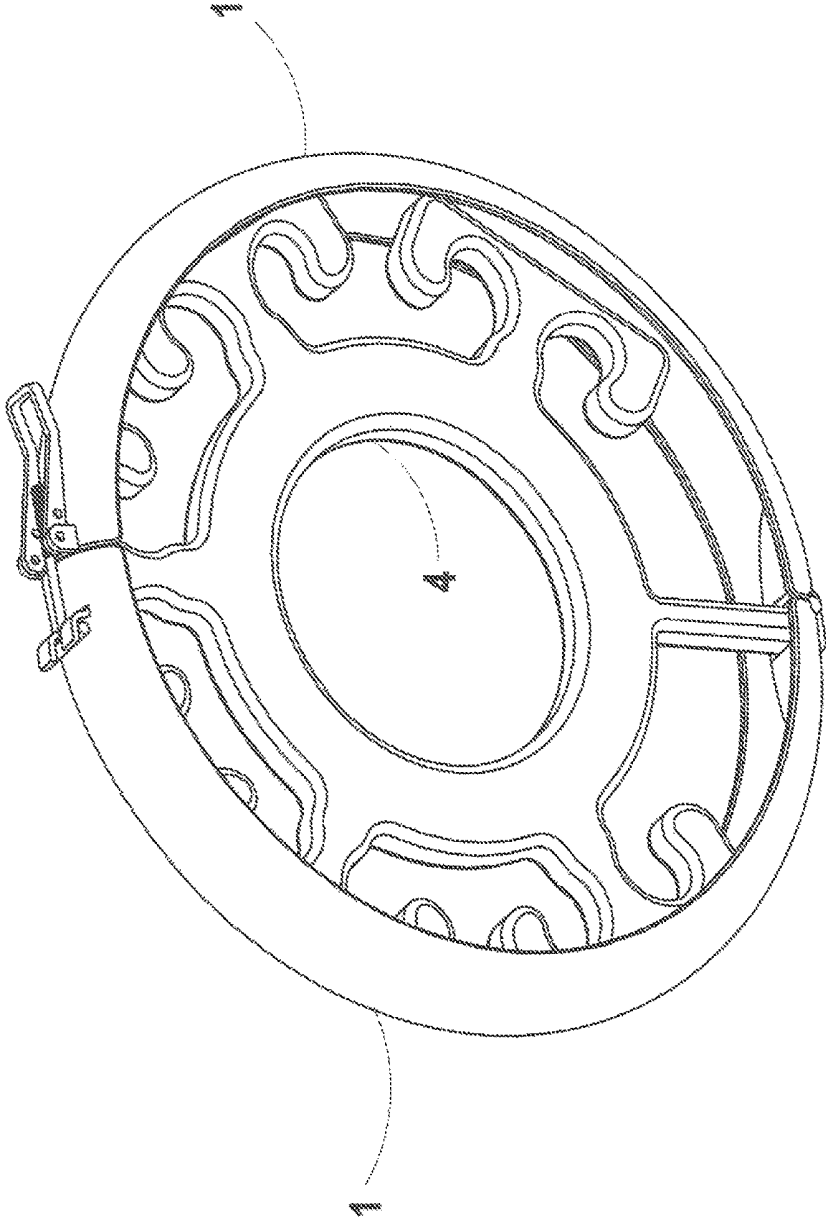

FIG. 8

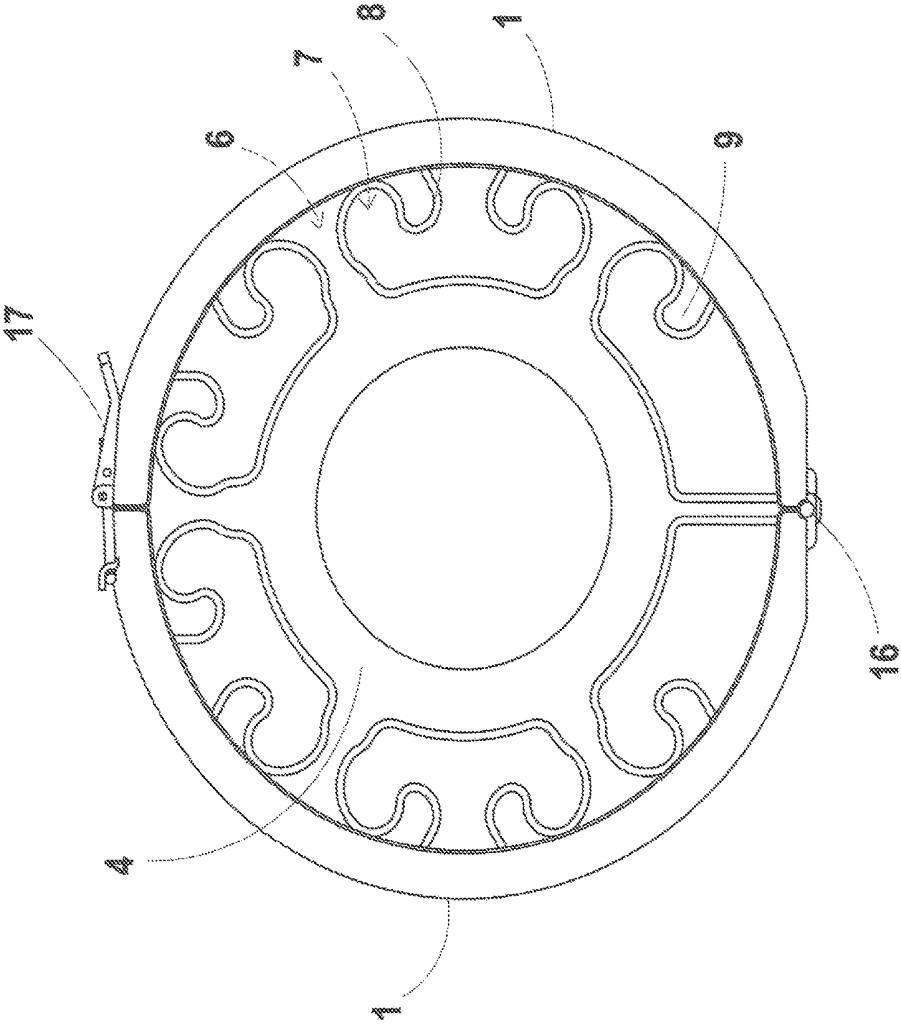

FIG. 9

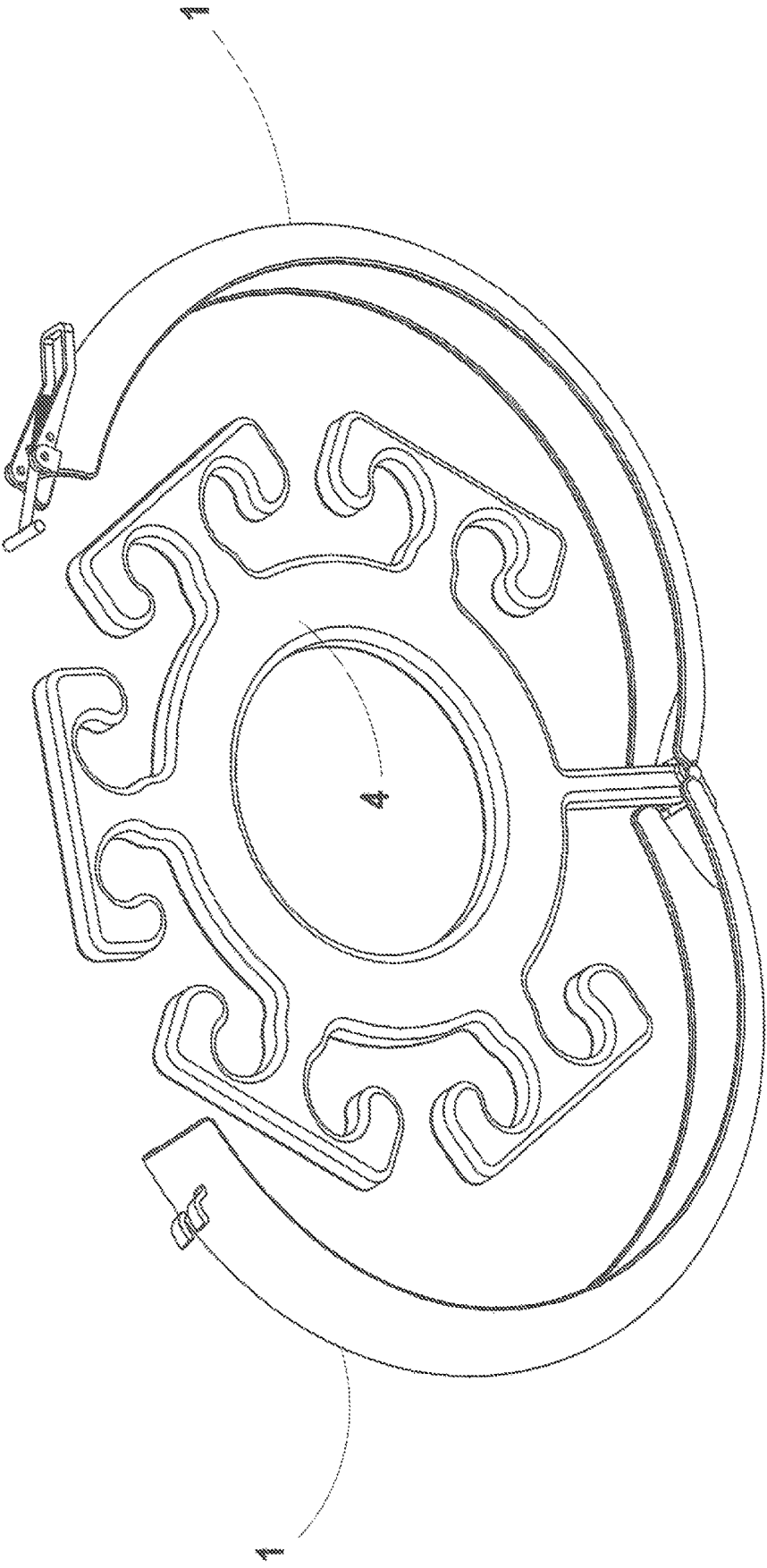

FIG. 10

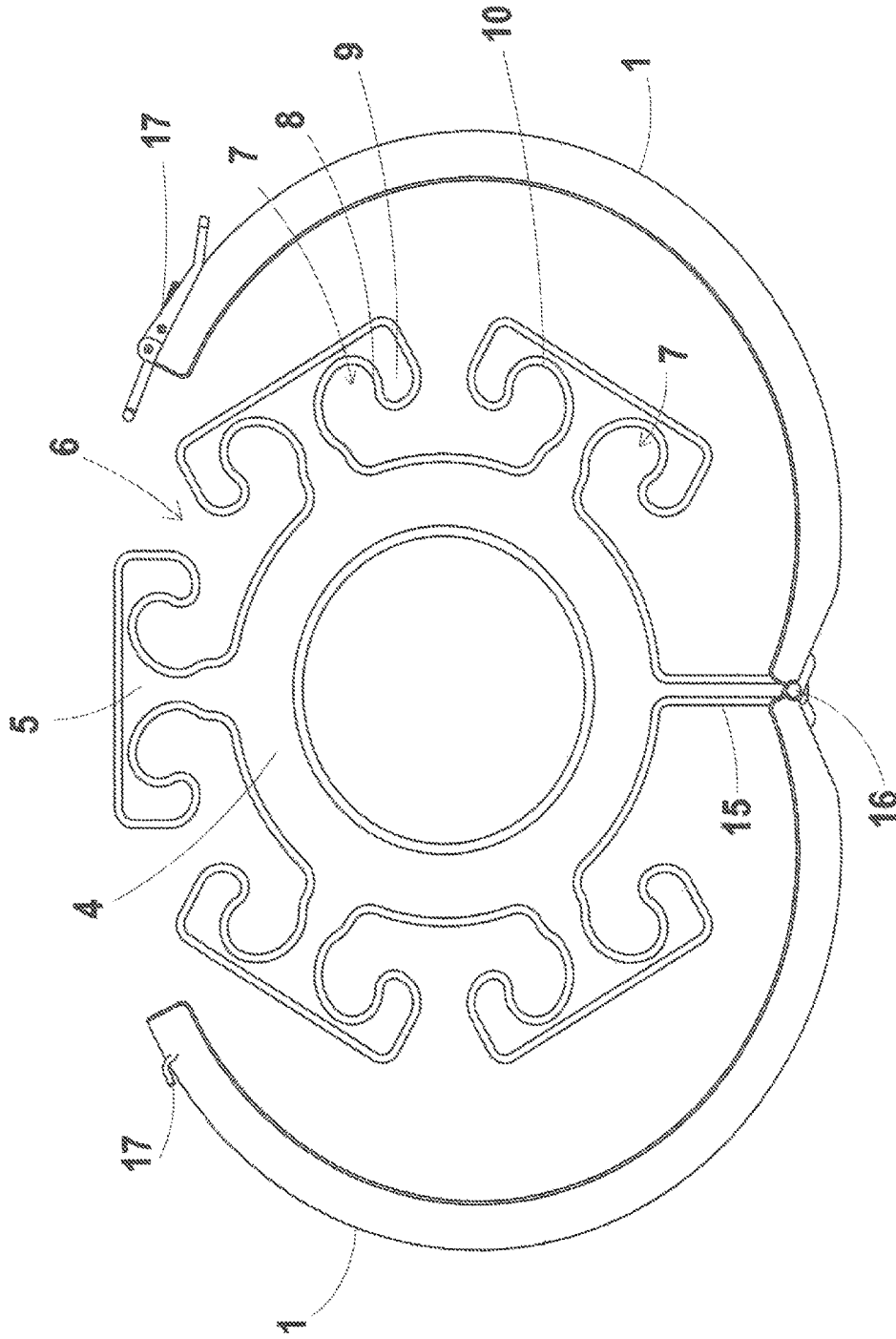

FIG. 11

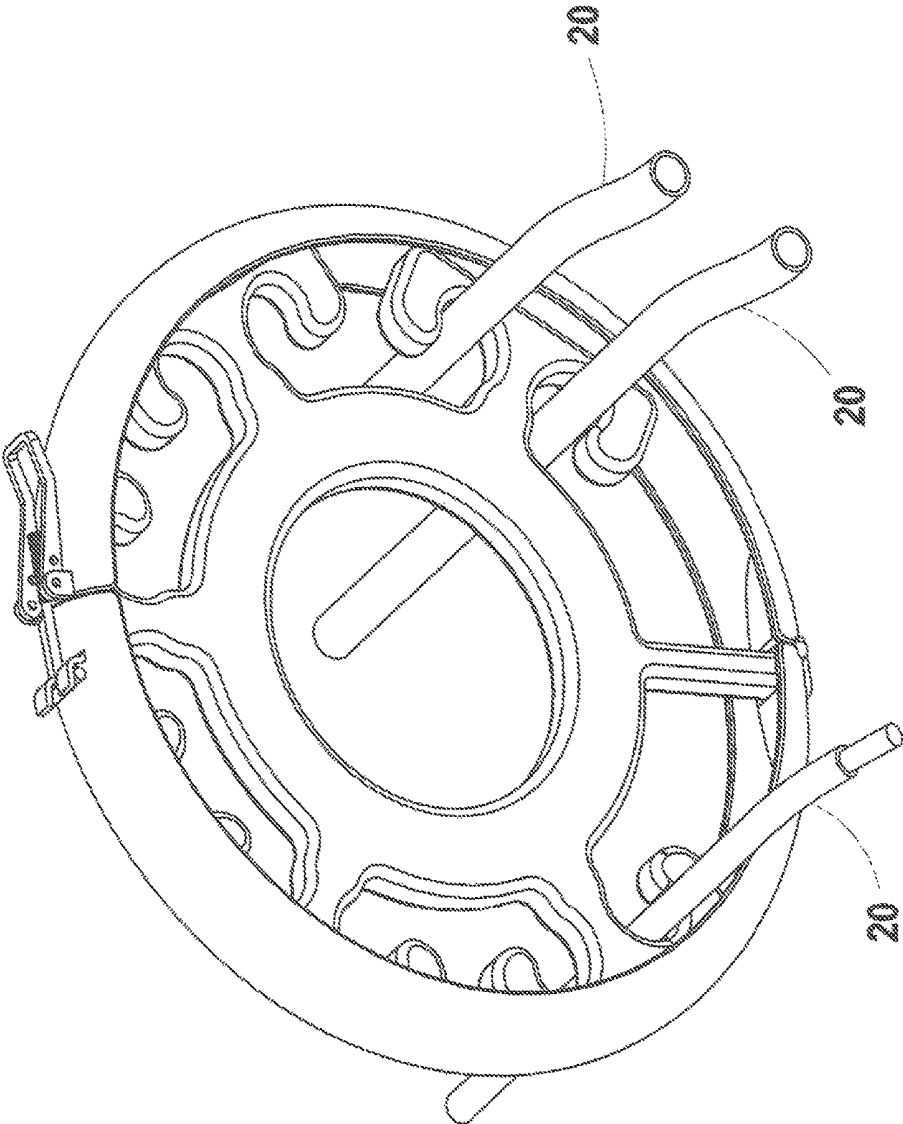

FIG. 12

CABLE, WIRE AND TUBE ORGANIZER FOR LAPAROSCOPIC AND HYSTEROSCOPIC SURGERY

CROSS-REFERENCE TO RELATED APPLICATIONS

This application claims the benefit of U.S. Provisional Application No. 62/457,206, filed on Feb. 10, 2017. The entire disclosure of the above application is hereby incorporated herein by reference.

FIELD

The present disclosure relates to a surgical instrument which facilitates conducting laparoscopic and hysteroscopic surgeries by organizing the cables going to the instruments on the surgical field.

BACKGROUND

The statements in this section merely provide background information related to the present disclosure and may not constitute prior art.

Minimally invasive surgery is becoming the most prevalent type of surgery performed in the United States. It allows for greater recovery times, minimizes the need for hospital admissions, minimizes scarring and affords greater safety, superior visualization and minimizes blood loss. Both laparoscopic pelvic surgery and hysteroscopic surgery utilize complex equipment, each of which requires a tube, cable or wire. For instance, the typical laparoscopic surgical field, while performing a hysterectomy, comprises of a video cable (for the operative camera), a light-cord cable (to illuminate the pelvis), a cautery cable (to cauterize bleeding) and a directed energy cable (for devices capable of cutting and sealing tissues). In addition, a gas tube (to create and maintain abdominal pneumoperitoneum), a twin tube for the laparoscopic suction and irrigator also course through the surgical field.

Oftentimes, these cables get tangled which may slow down the surgery or, occasionally, create situations that may potentially be dangerous to patients. Instruments which are not secured may fall to the ground or may dangle below the surgical drapes where they may become contaminated and potentially cause infection and sepsis. Being able to secure the cables and tubes is therefore critical to performing safe surgeries yet presently no device adequately addresses these problems.

In this domain, all the devices of the prior art have drawbacks, and are not readily accepted by surgeons for practical and safety issues. For example, International Patent Application Publication No. WO2011097072 and U.S. Patent Application Publication No. 20110084039, both to Walters et al., describe a device with clamps. However, the Walters et al. device cannot be mounted vertically for hysteroscopic surgery and the design of the clamps may damage delicate cables such as fiber optical light cables.

The U.S. Pat. No. 5,224,674 to Simons describes an apparatus for organizing intravenous fluid lines. However, the Simons device prevents tubes from sliding freely through its body and is too bulky to use within a crowded sterile field in the operating room. The U.S. Pat. No. 4,579,310 to Wells et al. describes an electrical guide for organizing wires. However, the Wells et al. device would be unsuitable for hollow tubes and would be difficult to secure to the surgical field.

There is a continuing need for a cable, wire and tube organizer for use during medical procedures such as surgery, and which offers solutions to overcome the many drawbacks of previous cable organizers and displays a number of desirable features.

SUMMARY

In concordance with the instant disclosure, a cable, wire and tube organizer for use during medical procedures such as surgery, and which offers solutions to overcome the many drawbacks of previous cable organizers and displays a number of desirable features, is surprisingly discovered.

In one embodiment, an organizing device for use during a medical procedure includes a main body and a latching mechanism. The main body has a plurality of integral holders configured to secure at least one of a cable, a wire, and a tube during the medical procedure such as a surgery or operation. Each of the integral holders has at least one insertion slot with an inwardly tilted tooth for receiving the one of the cable, the wire, and the tube. The main body further has attachment means configured to secure the main body to a surgical field. The latching mechanism is pivotally attached to the main body and selectively movable between an open position and a closed position. The latching mechanism is configured to permit the insertion of the one of the cable, the wire, and the tube in the insertion slot when in the open position. The latching mechanism is also configured to occlude the insertion slots when in the closed position, and thereby secure the one of the cable, the wire, and the tube in the insertion slot.

In an exemplary embodiment, the organizing device includes a substantially flat main body with no separable parts, one or several integral rings, integral holders, and a latching mechanism.

The one or several integral rings are of sufficient strength for securing the device to the surgical field. The rings are integrally part of the main body of the device. The rings are capable of quickly securing the device and removing the device. The rings are capable of accepting hook-and-loop fastener (Velcro™) tabs, surgical towel clamps, or other means of securing the device to the surgical field. The rings allow the device to be mounted vertically or horizontally.

The integral holders of the device may be a plurality of holders that are integrally part of the main body of the device. The integral holders have an insertion slot wide enough to allow cables and an inwardly tilted tooth. The integral holders also have an area bounded by a resting surface, and the integral holder and the inwardly tilted tooth have a generally circular cross section. All surfaces of the integral holders have rounded contours, and are of sufficient size to accommodate cables and tubes typically used during laparoscopic and hysteroscopic surgery. The integral holders are also shaped to that inserted cables must negotiate a generally S-shaped path prior to resting on the resting surface.

The latching mechanism of the device may be capable of occluding the insertion slots of the integral holders. The latching mechanism may be retractable, and secured to the main body by a permanent fastener such as a rivet or other support. The latching mechanism may be secured from opening inadvertently through friction or by a fastener such as a cam latch.

In one example, the device is comprised of a substantially rectangular body. The substantially rectangular body has a top section with an integral ring at the center, a second integral ring, a bottom section, and a pivot point. The second

integral ring is located at one end of the main body. The bottom section has a plurality of integrated holders. The pivot point permits attachment of a latching mechanism. The pivot point may have a U-shaped cross section and is secured to the main body through a fastener. The pivot point may have a friction closure mechanism preventing free movement.

The device may further have no separable parts. The main body and the latch may each be produced by injection molding. For example, the device may be composed of a general-purpose polypropylene copolymer. In another example, the device is composed of stainless steel. The means for connecting may also be provided in the form of a rivet. In certain examples, the friction mechanism may include grooves molded into the area about the pivot point. The plurality of hooks may be four (4), and in a most particular example may be six (6). Advantageously, the device is disposable, although in some instances the device may be sterilized for reuse.

In another example, the device is comprised of a substantially donut shaped body. The donut shaped body has a central integrated ring. The central integrated ring is hollow, and integrally molded in the main body of the device. The hollow portion of the central integrated ring is capable of accepting hook-and-loop fastener (e.g., Velcro™) tabs, surgical towel clamps, or other means of securing the device to the surgical field. The central integrated ring has radially arranged integral holders located along the outer perimeter of the main body and integrally part of the main body of the device. The central integrated ring also has a radial support allowing the retention of a cylindrical latch mechanism. The cylindrical latch is capable of occluding the insertion slots, and may include two identical half cylinders, a curvilinear cross section permitting a flush fit against the insertion slots, a hinge joining the two half cylinders to the radial support, and a cam latch catch allowing for fasteners to secure the two half cylinders together.

Several objects and advantages of the present invention are provided, namely: a) a device capable of accepting, retaining and organizing multiple cables wires and tubes; b) a mechanism allowing the cables to be secured to the device after insertion; c) a device capable of accepting tubes and wires of various diameters without scuffing or rubbing the insulation around them; d) a device capable of being secured either to the surgical drape itself, to an attachment on the mayo stand or to the IV poles at the head of the surgical field; e) a device which may be used for robotic, laparoscopic or hysteroscopic surgery; f) a device which may retain a bag containing surgical instruments which are not currently being used; g) a device which is flat and may sit flush with the surgical field; h) a device which may be sterilized; i) a device may be disposable; j) a device which may be injection molded; k) a device which is inexpensive to manufacture; l) a device which is safe to use and has no sharp angles; m) a device that has no loose or separable parts; n) a device that withstands the loads applied; and o) a device that is easy to use.

Further areas of applicability will become apparent from the description provided herein. It should be understood that the description and specific examples are intended for purposes of illustration only and are not intended to limit the scope of the present disclosure.

DRAWINGS

The drawings described herein are for illustrative purposes only of selected embodiments and not all possible implementations, and are not intended to limit the scope of the present disclosure.

FIG. 1 is a top perspective view of a cable organizer according to one embodiment of the present disclosure, the cable organizer shown with a latch opened;

FIG. 2 is a side elevational view of the cable organizer of FIG. 1, the cable organizer shown with the latch closed;

FIG. 3 is a side elevational view of the cable organizer of FIG. 1, the cable organizer shown with the latch opened;

FIG. 4 is a partial, enlarged, top perspective view of a main body of the cable organizer of FIG. 1;

FIG. 5 is a side elevational view of the main body of the cable organizer of FIG. 1.

FIG. 6 is a top perspective view of the latch of the cable organizer of FIG. 1;

FIG. 7 is a top perspective view of the cable organizer of FIG. 1, the cable organizer shown in operation and securing cables;

FIG. 8 is a top perspective view of a cable organizer according to another embodiment of the present disclosure, the cable organizer shown with latches closed;

FIG. 9 is a side elevational view of the cable organizer of FIG. 8;

FIG. 10 is a top perspective view of the cable organizer of FIG. 8, the cable organizer shown with the latches opened;

FIG. 11 is a side elevational view of the cable organizer of FIG. 10; and

FIG. 12 is a top perspective view of the cable organizer of FIG. 9, the cable organizer shown in operation and securing cables;

DETAILED DESCRIPTION

The following detailed description and appended drawings describe and illustrate various embodiments of the invention. The description and drawings serve to enable one skilled in the art to make and use the invention, and are not intended to limit the scope of the invention in any manner. In respect of the methods disclosed, the steps presented are exemplary in nature, and thus, the order of the steps is not necessary or critical unless otherwise disclosed.

A cable organizer according to a first embodiment of the disclosure is shown in FIGS. 1-7. The first embodiment is shown in a perspective view in FIG. 1 in the general position that the device will assume while in use. FIG. 2 illustrates a side view of the device, with the latch 1 in the open position, as it would be prior to setting up the device for a surgery. The "organizer" may be secured to the surgical drape through a hook-and-loop fastener (e.g., Velcro™), or through a simple towel clamp, affixed to the drape and to the integral rings 2 and 3. The integral ring on the end 2 would typically be used when using the hook-and-loop fastener near the fenestrated portion of the laparoscopic drape or while conducting hysteroscopic surgery where the device would be used vertically and placed near the patient's midline. The center integral ring 3 may be used during laparoscopic cases, when the device is mounted horizontally to the mayo stand at the foot of the bed or in-between the intravenous poles at the head of the table. Surgeon's preference, type of case and position of the laparoscopic tower relative to the patient would influence a vertical or horizontal deployment.

As shown in FIGS. 1-7, the organizer body 4 is generally rectangular shaped and includes integral holders, which are essentially carvings or molded portions, along the bottom side 5. Each integral holder consists of one insertion slot 6 leading up to two resting surfaces 7 of sufficient size to accommodate laparoscopic tubes and cables. Each resting surface 7 is bounded by the integral holder wall 8 and by an inwardly tilted tooth 9 which extends above the plane of the

resting surface and which retains and prevents cables from escaping through the insertion slot. Cables and tubes which are inserted through the insertion slot must negotiate an S shaped path before resting on the resting surface. This complex path also prevents cables from inadvertent escape. The cross-sectional area of the resting surface, integral holder wall and tooth each have a rounded, preferably circular, curvature **10** so as to maximize contact area with wires and tubes inserted into this space.

The inwardly tilted tooth and the slot each have rounded contours **11** to prevent cable chafing and ensure patient and surgeon safety. A rotating U-shaped latch **1**, shown in FIG. **6**, which is secured to the main body of the device **4** through a permanent fastener (such as a rivet) located at the pivot point **12**, is then rotated into place, thus securing the cables by blocking all of the insertion slots FIG. **1**. The latch itself is prevented from opening due to friction between itself and the main body of the device. Both of these parts have, at the level of the fastener, a friction ring consisting of radial grooves or raised portions **13** molded into the plastic and which increase friction FIG. **5**.

In the disclosed embodiment, the organizer has a flat cross section, allowing it to remain flush with the surgical field, while the latch is U-shaped. The device may be dimensioned as desired but the preferred dimensions are as follows: thickness: $\frac{1}{4}$ inch, total length: 10 inches, total width: 2.5 inches.

When in use, the load from the cables and tubes **20** which the integral holder supports and transfers to the entire device is relatively minimal, thus minimum strain is expected. This allows for relatively lightweight plastics and injection molded techniques to be used and for costs of manufacture to be relatively low.

A second embodiment of this device, which is substantially similar to a donut in appearance, is depicted in FIGS. **8-12**. Similar to the device described previously, integral holders **5** are formed in a circular main body **4**. As described previously, each integral holder consists of one insertion slot **6** leading up to two resting surfaces **7**. Each resting surface is bounded by the integral holder wall **8** and by an inwardly tilted tooth **9** which extends above the plane of the resting surface preventing cables **20** from easily escaping through the insertion slot. The inwardly tilted tooth and the slot each have rounded contours. Additionally, the resting surface, integral holder wall and surface of the tooth all have a circular curvature to better grip the wires and tubes inserted into this space **10**. Similar to the previously described embodiment, the central part of this embodiment consists of an integral ring **3**, resembling a donut hole, allowing device to be secured to the surgical field (also known as the operating field, which is an isolated area where surgery is performed, and which is kept sterile by aseptic techniques such as drapes, curtains, or shields).

The main body of this organizer is then encircled by a cylindrical latch **1**. When secured, its inner surface rests flush against the integral holders and thus securing the cables by blocking all of the insertion slots **6**. The cylindrical latch, secured to the main body by means of a radial support **15**, it is constructed out of two separate halves, each having a slightly inwardly curved cross section, similar to a tire, as shown in FIGS. **10** and **11**. A hinge **16** joins together the two half cylinders and the radial support allowing them to open and close about the end of the cylindrical latch. A cam latch catch mechanism **17** secures the cylindrical latch closed. The curvilinear cross section increases safety, by providing no sharp edges which may harm the patient, while allowing for a better fit around the main body.

Thus, is provided a minimally invasive surgical cable organizer that may be used in a laparoscopic or hysteroscopic setting and which fulfills the objects of the invention. In all embodiments, the device is all essentially one-piece and has no separable parts (such as screws) which may be removed and lost in a patient's body.

While the invention is described in specific embodiments, many alternatives, modifications and variations, which will be apparent to those skilled in the art, fall within the spirit and scope of the claims.

What is claimed is:

1. An organizing device for use during a medical procedure, comprising:

a main body having a hanger and a plurality of integral holders configured to secure at least one of a cable, a wire, and a tube during the medical procedure, each of the integral holders defined by a generally T-shaped holder body depending from the hanger, the holder body having a first side and a second side, each of the first side and the second side having an inwardly tilted tooth and a resting surface for receiving the one of the cable, the wire, and the tube, and each of the first side and the second side further having an integral holder wall surface, an insertion slot surface, and an inwardly tilted tooth surface, the resting surface bounded by the integral holder wall surface and the inwardly tilted tooth surface, and the insertion slot surface disposed adjacent to an insertion slot formed in the main body, the hanger of the main body further having attachment means configured to secure the main body to a surgical field; and

at least one latching mechanism that is pivotally attached to the main body and selectively movable between an opened position and a closed position, the latching mechanism configured to permit the insertion of the one of the cable, the wire, and the tube in the insertion slot when in the opened position, and configured to occlude the insertion slots when in the closed position, and thereby secure the one of the cable, the wire, and the tube in the insertion slot,

wherein the hanger of the main body is substantially rectangular in shape, and further has a top section with an integral ring at a center of the main body, a second integral ring located at one end of the main body, a bottom section having the plurality of integral holders, and a pivot point to which the latching mechanism is pivotally attached,

wherein the integral ring at the center and the second integral ring are the attachment means, and

wherein the latching mechanism has a U-shaped cross section and is secured to the main body at the pivot point through a fastener, the U-shaped cross section defining a channel that receives the integral holders when the latching mechanism is in the closed position.

2. The device of claim 1, wherein the main body is elongate and has a pair planar surfaces, each of the planar surfaces on an opposite side of the main body.

3. The device of claim 1, wherein the main body has no separable parts.

4. The device of claim 1, wherein the integral ring and the second integral ring having sufficient strength for securing the device to the surgical field and integrally part of the hanger of the main body, the integral ring and the second integral ring configured to selectively and quickly secure and remove the device from the surgical field in one of a vertically mounted and horizontally mounted position.

5. The device of claim 4, wherein the integral ring and the second integral ring are each configured to accept at least one of hook-and-loop fastener tabs and surgical towel clamps for securing the device to the surgical field.

6. The device of claim 1, wherein the generally T-shaped holder body is defined by a vertical bar depending from the hanger and a horizontal bar disposed on an end of the vertical bar and oriented generally parallel with the hanger, the tilted tooth on each of the first and the second side of the integral holder disposed at an end of the horizontal bar and extending inwardly toward each of the hanger and the vertical bar of the generally T-shaped holder body.

7. The device of claim 1, wherein each surface of the integral holders has rounded contours.

8. The device of claim 1, wherein each of the integral holders is shaped so that the one of the cable, the wire, and the tube must negotiate a generally S-shaped path prior to being secured, and wherein the insertion slot surface, the inwardly tilted tooth surface, the resting surface, and the integral holder wall surface together define the generally S-shaped path.

9. The device of claim 1, wherein the latching mechanism is secured to the main body with a permanent fastener.

10. The device of claim 9, wherein the permanent fastener is a rivet.

11. The device of claim 9, wherein an inadvertent opening of the latching mechanism is militated against by at least one of a friction feature and a fastener.

12. The device of claim 1, wherein at least one of the latching mechanism and the main body has a friction feature at the pivot point that militates against free movement of the latching mechanism relative to the main body.

* * * * *

专利名称(译)	用于腹腔镜和宫腔镜手术的电缆，电线和管子整理器		
公开(公告)号	US10433926	公开(公告)日	2019-10-08
申请号	US15/893806	申请日	2018-02-12
[标]申请(专利权)人(译)	RECANATI MAURICE ANDRE		
申请(专利权)人(译)	RECANATI, 莫里斯 - 安德烈·		
当前申请(专利权)人(译)	RECANATI, 莫里斯 - 安德烈·		
[标]发明人	RECANATI MAURICE ANDRE OZBEKI MOHAMMAD ALI E KRAMER KATHERINE J TAMAKUWALA SEJAL		
发明人	RECANATI, MAURICE-ANDRE OZBEKI, MOHAMMAD ALI E. KRAMER, KATHERINE J. TAMAKUWALA, SEJAL		
IPC分类号	A61B50/20 F16L3/223 F16L3/10		
CPC分类号	A61B50/20 F16L3/2235 F16L3/1075		
优先权	62/457206 2017-02-10 US		
其他公开文献	US20180228564A1		
外部链接	Espacenet		

摘要(译)

公开了一种在医疗过程中使用的组织装置，当在腹腔镜或宫腔镜手术中使用该装置时，该装置使外科医生能够保持多根管子，电线和电缆井井有条。在第一实施例中，该装置可以具有矩形主体，在其中心处具有整体环的顶部和具有多个插槽的底部，该插槽被优化用于电缆和管的插入和保持。所述端部部分在一端包括第二整体环，在另一端包括枢转点，所述枢转点允许摩擦闭锁机构固定所述狭槽。在第二实施例中，该装置可以具有甜甜圈形状的主体，在中心处的整体环以及在径向上布置在外围并且通过圆柱形闭锁机构固定的多个狭槽。

