



US008728093B2

(12) **United States Patent**  
**Rousseau et al.**

(10) **Patent No.:** **US 8,728,093 B2**  
(45) **Date of Patent:** **May 20, 2014**

(54) **COMPRESSION, BANDING AND PERCUTANEOUS AIRWAY LIGATION OF EMPHYSEMATOUS LUNG TISSUE**  
(75) Inventors: **Alexandra Rousseau**, Cambridge, MA (US); **Mark Wood**, Shrewsbury, MA (US); **Jon T. McIntyre**, Newton, MA (US); **Claude Clerc**, Marlborough, MA (US); **Gary Leanna**, Holden, MA (US); **Michael S. H. Chu**, Brookline, MA (US)

(73) Assignee: **Boston Scientific Scimed, Inc.**, Maple Grove, MN (US)

(\* ) Notice: Subject to any disclaimer, the term of this patent is extended or adjusted under 35 U.S.C. 154(b) by 981 days.

(21) Appl. No.: **12/209,591**

(22) Filed: **Sep. 12, 2008**

(65) **Prior Publication Data**  
US 2009/0076526 A1 Mar. 19, 2009

**Related U.S. Application Data**  
(60) Provisional application No. 60/973,269, filed on Sep. 18, 2007.

(51) **Int. Cl.**  
**A61B 17/10** (2006.01)

(52) **U.S. Cl.**  
USPC ..... **606/139; 623/23.65**  
(58) **Field of Classification Search**  
USPC ..... 623/23.65; 606/139, 140  
See application file for complete search history.

(56) **References Cited**  
**U.S. PATENT DOCUMENTS**  
6,174,323 B1 \* 1/2001 Biggs et al. .... 606/232  
6,416,554 B1 \* 7/2002 Alferness et al. .... 623/23.65  
6,514,290 B1 \* 2/2003 Loomas ..... 623/23.65  
2005/0216042 A1 \* 9/2005 Gertner ..... 606/151

\* cited by examiner  
*Primary Examiner* — Gregory Anderson  
(74) *Attorney, Agent, or Firm* — Fay Kaplun & Marcin, LLP

(57) **ABSTRACT**  
A lung volume reduction system includes a percutaneously, laparoscopically or thoroscopically insertable delivery element comprising a control end which remains outside the body and an insertion end which, when in an operative position, is adjacent to an external surface of a target portion of a lung and a constriction element deployable from the distal end of the delivery element to apply compressive force to an external surface of the target portion of the lung to constrict at least one airway therein and collapse the target portion of the lung.

**14 Claims, 3 Drawing Sheets**

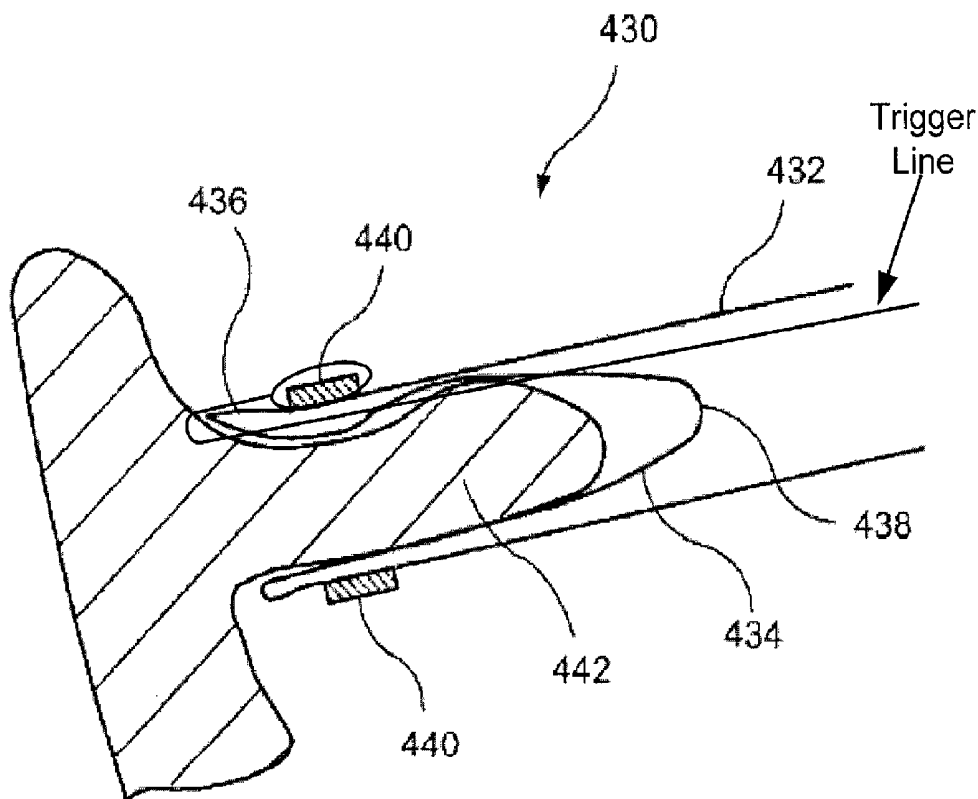

FIG. 1

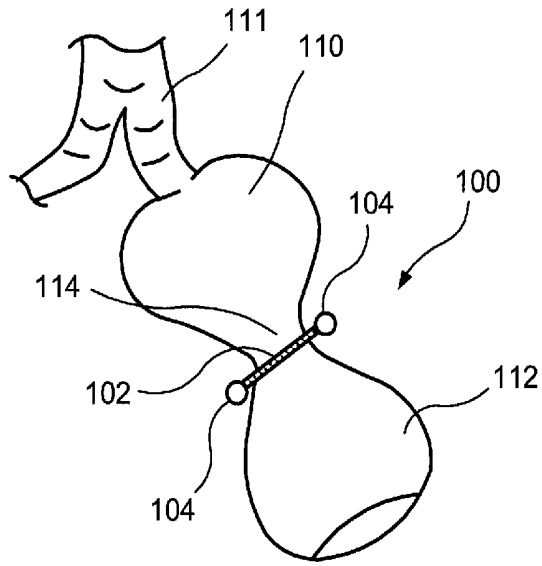

FIG. 2

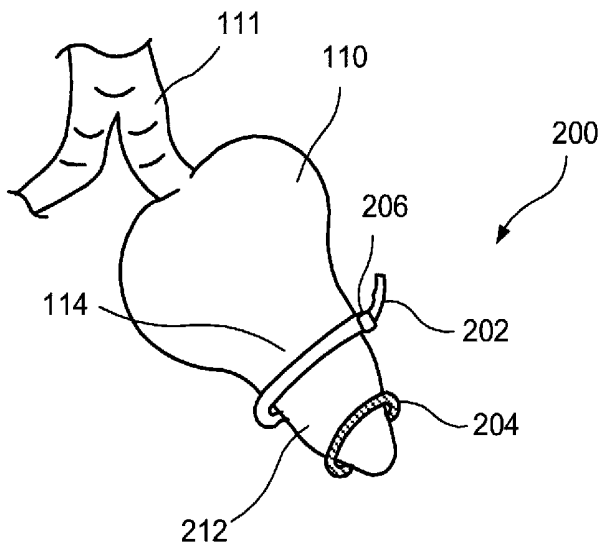
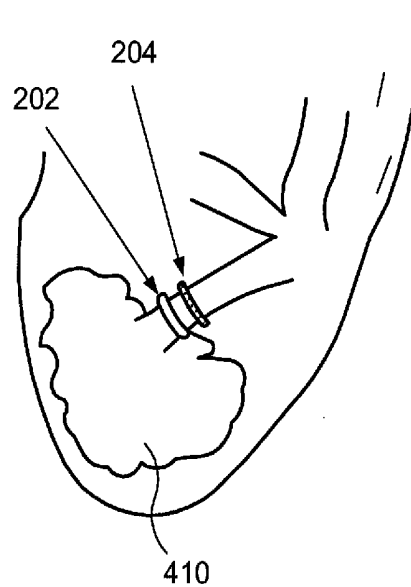

FIG. 3



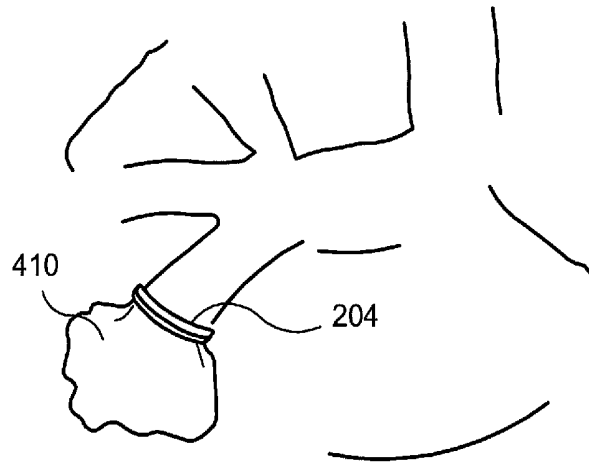

FIG. 4

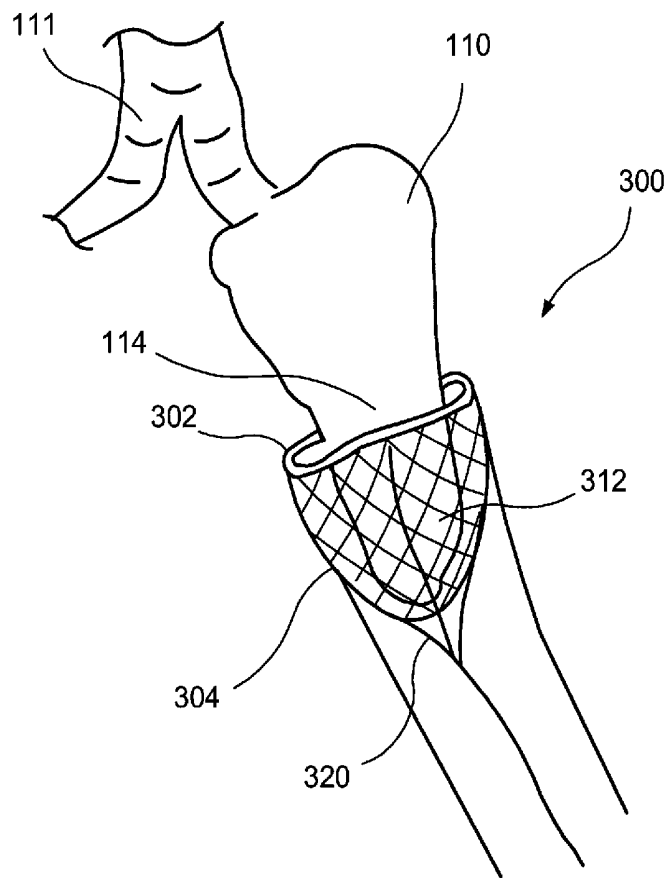
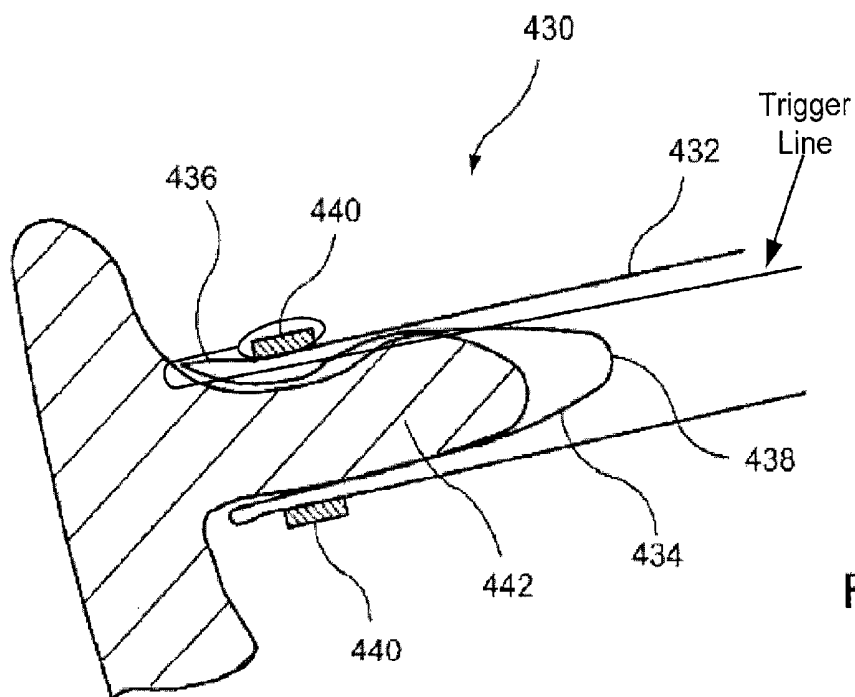
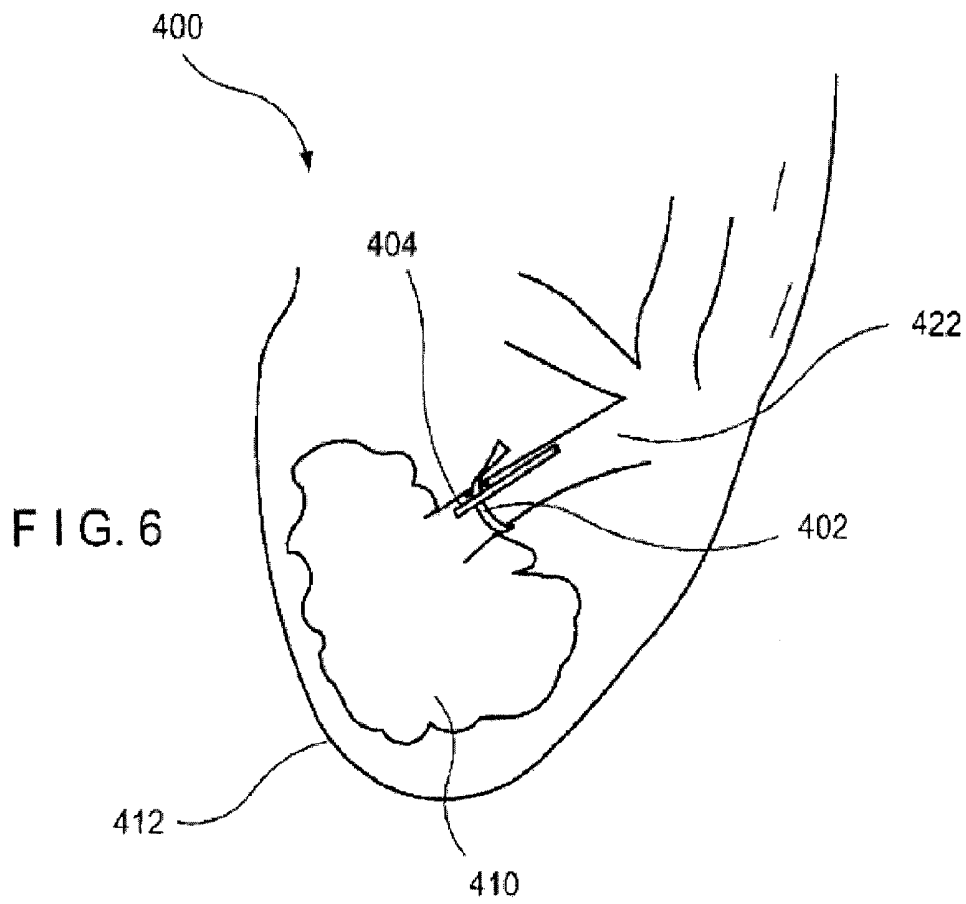

FIG. 5



## COMPRESSION, BANDING AND PERCUTANEOUS AIRWAY LIGATION OF EMPHYSEMATOUS LUNG TISSUE

### PRIORITY CLAIM

This application claims the priority to the U.S. Provisional Application Ser. No. 60/973,269, entitled "Compression, Banding and Percutaneous Airway Ligation of Emphysematous Lung Tissue," filed Sep. 18, 2007. The specification of the above-identified application is incorporated herewith by reference.

### BACKGROUND

Emphysema, a progressive, often incurable disease of the lungs often results from chronic infection or irritation of the bronchial tubes. As the bronchial tubes become irritated, some of the airways may be obstructed, trapping air in the alveoli. As this process continues, the alveoli become enlarged and exchange oxygen for carbon dioxide less efficiently. Furthermore, these expanded portions of the lungs may compress adjacent healthy portions of the lungs interfering with their functioning.

Lung volume reduction surgery (LVRS) is one treatment used to relieve the symptoms of emphysema by removing diseased portions of the lungs to create more room for the remaining healthy portions. Although LVRS has been shown to improve pulmonary function and the survival rate in selected patients the complications associated with such major, open surgical procedures make LVRS unsuitable for certain patients.

Minimally invasive procedures have also been employed to achieve results similar to those of LVRS while minimizing the associated complications. These less invasive procedures generally involve depositing in the lungs devices that restrict the flow of air to the diseased portions of the lungs. Often, a bronchoscope or laparoscope is used to deliver the devices obviating the need for surgical openings into the chest cavity.

### SUMMARY OF THE INVENTION

The present invention is directed to a lung volume reduction system comprising a percutaneously insertable delivery element comprising a control end which remains outside the body and an insertion end which, when in an operative position, is adjacent to an external surface of a target portion of a lung and a constriction element deployable from the distal end of the delivery element to apply compressive force to an external surface of the target portion of the lung to constrict at least one airway therein and collapse the target portion of the lung. As would be understood by those skilled in the art, this collapsed condition may, if desired, be continued for a period of time sufficient to necrose the collapsed portion of tissue permanently eliminating the inefficiencies of this diseased portion of tissue from the lung.

### DESCRIPTION OF THE DRAWINGS

FIG. 1 is a diagram showing an embodiment of a device used to collapse a lung according to the present invention;

FIG. 2 is a diagram showing another embodiment of a device used to collapse a lung using a mechanical tie according to the present invention;

FIG. 3 is a diagram showing an embodiment of a percutaneous airway lung ligation band according to the present invention, during deployment; and

FIG. 4 is a diagram showing the lung ligation band of FIG. 3 after deployment; and

FIG. 5 is a diagram showing a further embodiment of a device used to collapse a desired portion of lung using an elastic bag, according to the present invention;

FIG. 6 is a diagram showing a further embodiment of a device used to collapse a desired portion of lung according to the present invention; and

FIG. 7 shows an apparatus according to a further embodiment of the invention for collapsing a desired portion of lung.

### DETAILED DESCRIPTION

The present invention may be further understood with reference to the following description and the appended drawings, wherein like elements are referred to with the same reference numerals. The present invention relates to devices for treatment of emphysema and more specifically relates to devices for reducing the size of diseased lung tissue to improve the functioning of remaining healthy tissue.

According to embodiments of the present invention, a percutaneous procedure is employed to access diseased regions of the lungs and to deploy thereto devices to reduce the volume of the diseased tissue increasing the efficiency of the healthy tissue.

The exemplary embodiments of the present invention comprise procedures employing banding and/or compression devices to reduce the volume of emphysematous tissue. Depending on the details of a particular case, these devices may be deployed from outside or within the lung. The exemplary devices according to the present invention isolate targeted tissue from portions of the lungs upstream thereof to reduce the volume by preventing further influx of air. Other devices according to the invention compress the target tissue to decrease its volume.

FIG. 1 shows an exemplary embodiment of a system **100** for collapsing a target portion of the lung by clamping or pinching a lobe of the lung. The system **100** includes a rivet or peg **102** which is placed into the thoracic cavity and inserted through a target lobe **112** of a lung **110**. The rivet or peg **102** is preferably inserted minimally invasively through, for example, a laparoscope or thoracoscope introduced between the ribs into the thoracic cavity via a small incision with a distal end of the peg **102** being inserted through the target lobe **112** and secured in place by tightening to desired dimensions using conventional locking mechanisms or anchoring members **104**. For example, the system **100** may include a tube of substantially circular cross-section through which suction may be applied to draw a portion of lung tissue into the tube after which an elastic ligator may be pushed off the distal end of the tube so that the elastic ligator contracts to constrict the portion of the lung which has been drawn into the tube. Alternatively, as would be understood by those skilled in the art, a tie wrap may be placed around a target portion of the lung and then an end of the tie wrap may be drawn out to tighten the tie wrap around the target portion and constrict the target portion of tissue. After the distal end of the peg **102** has passed through the target lobe **112** to a desired position on a side opposite a point of insertion into the target lobe **112**, a first anchor member **104** is attached to or, alternatively, deployed from, the distal end of the peg **102** and the target lobe **112** is compressed against the first anchor member **104** to a desired degree. The distal end of the peg **102** is prevented from being pulled back into the interior of the target lobe **112** by the first anchor member **104** which engages an exterior of the target lobe **112**. Compressing the target lobe **112** against the distal end of the peg **102** reduces the volume of the target

lobe **112** by creating a neck region **114** of reduced cross-sectional area. When a desired amount of compression of the target lobe **112** has been achieved, a second anchor member **104** is deployed from a proximal portion of the peg **102** to maintain the desired amount of compression of the target lobe **112**. After the second anchor member **104** has been deployed, any excess length of the peg **102** may be trimmed away and the laparoscope may be removed. Those skilled in the art will understand that the peg **102** and the anchoring members **104** are preferably adapted to engage portions of the exterior of the target lobe **112** large enough to hold the anchoring members **104** in position against forces applied thereto during respiration and as the patient moves about.

Constriction by the peg **102** collapses the bronchial passages in the neck region **114** preventing the passage of air to the target lobe **112** to inflate the alveoli contained therein. Thus surrounding healthy portions of the lung may inflate more freely and carry out the exchanges of gases more efficiently. Over time, the target lobe **112** will necrose because of the constriction further reducing its volume. In an alternative example, a peg **102** may be placed within a target lobe **112** and anchored across a target bronchial passage therein to prevent air flow only to that portion of the target lobe **112** served by the target bronchial passage.

A system **200** to reduce lung volume according to a second embodiment of the invention is shown in FIGS. 2-4. According to this exemplary embodiment, a mechanical element such as a tie or a clamp **202** is placed around a target portion **212** of the lung **110** to separate the target portion **212** from upstream portions of the lung **110** to collapse the target portion **212**. The tie or clamp **202** is applied around the lung **110** to compress the target portion **212** of the lung **110** downstream of an airway branch **111**. As with the peg **102** of the system **100**, the tie or clamp **202** is preferably inserted into the thoracic cavity through a minimally invasive method, such as through a laparoscopic procedure, and may be secured in place by tightening to the correct dimensions using a conventional locking mechanism **206**. Alternatively, the tie or clamp **202** may be replaced, or supplemented, by an elastic band **204** or a shape memory element which, when released around a target portion of the target lobe **212** will contract without the need for a locking mechanism to apply compression thereto. For example, the constriction element may be a loop of a shape memory material such as Nitinol formed so that, when deployed it reverts to a memorized shape with a reduced diameter. The elastic bands **204**, or other type of compression element, may also be applied through a laparoscopic procedure or other minimally invasive approach. For example, one or more elastic bands **204** may be disposed around a cylinder into which a portion of the target lobe **212** is drawn (e.g., by suction applied thereto) at which point a first one of the elastic bands **204** may be released (e.g., by drawing a trigger line attached thereto) to contract around the portion of the target lobe **212** adjacent to a distal end of the cylinder.

As shown in FIGS. 3 and 4 the system **200** collapses a target portion **410** of the lung by isolating it from remaining portions of lung to cut-off the supply of air thereto. A constriction element (e.g., a tie or clamp **202** or an elastic band **204**) is deployed from a delivery element onto the airway, so that the passage of air is blocked. For example, a tube such as an endoscope (not shown) may be inserted between the ribs into the thoracic cavity via an incision with one or more constriction elements received around a distal end of the endoscope. The distal end of the endoscope preferably includes a hollow chamber into which the target portion **410** may be drawn (e.g., under suction) so that the distal end of the endoscope and the constriction element received thereon surrounds the target

portion **410**. In this position, the constriction element is moved off of the distal end of the endoscope so that it encircles a portion of the lung upstream of the target portion **410**. When the constriction element is an elastic band **204**, the band **204** tightens immediately after it passes off of the distal end of the endoscope to constrict the lung tissue therewithin, preventing the flow of air therethrough. Ties or clamps **202** deployed in this manner are then tightened around the lung tissue to prevent the flow of air to the target portion **410**. Those skilled in the art will understand that these constriction elements may be formed of bioabsorbable materials which are preferably selected to retain their form until after a time required to achieve a desired therapeutic effect has elapsed. For example, such a bioabsorbable constriction element may be selected to remain in position, as shown in FIG. 4, until the target portion **410** has completely collapsed and the flow passage(s) thereto are sealed. As would be understood by those skilled in the art, the system **200** may deploy the ligating bands **204** using a mechanism substantially similar to an elastic band ligating system for treating esophageal varices as described, for example, in U.S. Pat. No. RE36,629 issued to Zaslavsky, et al., Mar. 28, 2000, the entire disclosure of which is hereby incorporated by reference.

As shown in FIG. 5, a system **300** according to an additional embodiment of the lung reduction system according to the invention includes an elastic bag or sock **304** which is stretched for placement around a portion of a target lobe **312** of the lung **110**. Upon release, the bag **304** contracts to apply a compressive force to a portion of a surface of the target lobe **312** of the lung **110** larger than that affected by the clamp **202** or the ligating band **204**. That is, the open end of the bag **304** constricts air flow into the target lobe **312** of the lung **110** as in the prior embodiments while the remaining portions of the bag **304** actively compress the target lobe **312**. As would be understood by those skilled in the art, the bag **304** may be designed to apply a compressive force which is substantially equal across the surface area of the target lobe **312** with which it is in contact. Alternatively, the bag **304** may be designed to apply a force which varies over the surface area. For example, the bag **304** may be designed to apply a force which is a maximum along a line which, when the bag **304** is in a desired position on the target portion of the lobe **312**, is furthest upstream on the lobe **312** (e.g., at the open end of the bag **304**) or to cause the collapse of portions of the target lobe **312** in a desired sequence. In the exemplary embodiment, the bag or sock **304** comprises a band **302** adapted to retain the device in place on the target portion of the lung **110**. For example, the band **302** may have an inner surface shaped to grasp the tissue of the lung and prevent it from slipping off the target lobe **312**. The band **302** may, for example, be made of an elastic material, or may be tightened mechanically as desired in a manner similar to that described above.

The bag or sock **304** according to the present invention is preferably made of a bioabsorbable material such as polyurethane or lycra so that it does not have to be removed after the compressed portion of the target lobe **312** has necrosed to a desired level. As with other embodiments of the present invention, the bag or sock **304** is designed to be placed using minimally invasive techniques. Specifically, the bag or sock **304** can be inserted into the body through a small incision or port on an elongated retractor device. The distal end of the retractor is generally maintained in a closed condition so that the sock **304** can be placed thereover to keep the retractor in a low profile. When the sock **304** is placed adjacent to the target lobe **312**, a handle of the retractor is activated to expand the sock **304** using, for example, three or more arms **320** for ease of placement over the target lobe **312**. The handle of the

retractor may be attached, via known means, to the plurality of arms 320 so that, upon activation, the arms extend radially outward from the device. Once the sock 304 is placed in the desired location, the arms of the retractor device may be retracted in order to release the hold on the sock 304. The arms 320 of the retractor can then be removed from the body in a closed position in order to minimize trauma to the patient.

As shown with respect to FIG. 6, the exemplary lung reduction system 400 is designed to be performed percutaneously to treat a target portion or lobe 410 of a lung 412. Those skilled in the art will understand that the percutaneous method may be used in conjunction with an imaging modality, such as, for example fluoroscopy. Alternately, a laparoscopic procedure may be employed to facilitate visual observation during the procedure. As another possibility, the procedure may be performed thoroscopically, via VATS or via the use of SPY fiber technology in one of the working channels of the scope, as those skilled in the art will understand. In this embodiment, the delivery element comprises a percutaneous axial member 404 (e.g., a flexible tube) used to deliver an elastic band 402 or other constriction element to an airway 422 such as a bronchial tube. A distal end of the axial member 404 is introduced into the body and placed adjacent to the airway 422 to be treated while a proximal end of the percutaneous axial member 404 remains outside the body for manipulation by a user for positioning of the distal end over a desired target portion of the lung 412.

As would be understood by those skilled in the art, a conventional mechanism, similar to those used for band ligation of esophageal varices, may be used to deploy the elastic band 402 from the axial member 404, so that the elastic band 402 wraps around and is anchored to a portion of the air passage 422 which had previously been drawn into the axial member 404. For example, as described above in regard to the embodiment of FIG. 2, a cord extending along the length of the percutaneous rod 404 may be used to pull one elastic band 402 at a time off the axial member 404, and release it over the air passage 422. In another embodiment, a longitudinal member may extend along the length of the axial member 404 so that the longitudinal member may slide along the length thereof to individually release the elastic bands 402. Alternatively, the elastic band 402 may have a length that can be varied by the user, so that it can be elongated to pass over the hyperinflated portion of the lung 410, and then shortened to tighten around the air passage 422. The elastic band 402, when released over the air passage 422, constricts to cut off air-flow to the hyperinflated target portion or lobe 410 from the rest of the lung 412 leading to necrosis of this target portion or lobe 410. The elastic band 402 is preferably formed of biodegradable material so that it may remain in place for a substantial amount of time to prevent re-inflation of the target lobe or portion 410', by blocking the air passing through the airway 422. As would be understood by those skilled in the art, the material of the elastic band 402 is selected to remain in position for a length of time sufficient to collapse the target lobe 410' to a desired level. In cases where the elastic band is not biodegradable, an additional procedure may be performed to remove the band 402 from the body after the desired level of collapse has been achieved.

As shown in FIG. 7, a system 430 similar to that described above in regard to FIGS. 3 and 4 may be used to deploy a bag or sock similar to those described above in regard to FIG. 5. The system 430 includes an axial member 432 with a bag or sock member 434 with an open end 436 wrapped around the distal end of the axial member 432. The closed end 438 of the sock member 434 extends within a lumen of the axial member 432 while an elastic member 440 extending around the open

end 436 holds the sock member 434 to the distal end of the axial member 432. After being advanced to a location adjacent a target portion 442 of lung to be treated in the same manner described above, the target portion 442 of lung is aspirated into the distal end of the axial member 432 via the application of suction or the manipulation of a grasper through the lumen of the axial member and the elastic member 440 is released from the distal end of the axial member 432 to constrict around the target portion maintaining the sock member 434 in position over the target portion 442.

The present invention has been described with reference to specific exemplary embodiments. Those skilled in the art will understand that changes may be made in details, particularly in matters of shape, size, material and arrangement of parts without departing from the teaching of the invention. Accordingly, various modifications and changes may be made to the embodiments without departing from the broadest scope of the invention as set forth in the claims that follow. The specifications and drawings are, therefore, to be regarded in an illustrative rather than a restrictive sense.

What is claimed is:

1. A method for treating a respiratory condition, comprising:

introducing a constriction element into the thoracic cavity via an incision;

drawing a target portion of the lung into an interior of an insertion instrument; and

deploying the constriction element from the insertion instrument and against an outer surface of an area upstream of the target portion of the lung to compress at least a part of the area upstream of the target portion to collapse the target portion of the lung, wherein the constriction element comprises one of a peg, an adjustable tie and an elastic member.

2. The method according to claim 1, wherein constriction element is the elastic member and wherein the elastic member is formed as an elastic band and wherein the elastic band is released to constrict around an upstream end of the target portion to prevent air from flowing between the target portion and an upstream portion of the lung.

3. The method of claim 2, further comprising actuating, after the target tissue has been drawn into the insertion instrument, a trigger line connected to the elastic band to deploy the elastic band from the insertion instrument around the target tissue.

4. The method according to claim 1, wherein the constriction element is the elastic member and wherein the elastic member is formed as an elastic bag and wherein the elastic bag is released to constrict around an outer surface of the target portion to apply a compressive force thereto.

5. The method according to claim 4, wherein the elastic bag applies a compressive force which is substantially uniform across a surface area of the target portion of the lung.

6. The method of claim 5, further comprising the step of expanding the elastic bag prior to positioning thereof over the target portion of tissue so that the elastic band constricts when released over the target tissue.

7. The method according to claim 1, wherein the constriction element is the peg and wherein the peg is inserted through the target portion of the lung and the insertion instrument includes a deploying mechanism advancing the peg through a first side of the target portion of the lung and an anchoring mechanism anchoring a distal end of the peg to an exterior surface of the target portion of the lung on a second side thereof opposite the first side, the anchoring mechanism anchoring a proximal end of the peg to an exterior surface of the first side of the target portion.

8. The method of claim 1, wherein a suction force is applied to the target portion of the lung to draw the target tissue into the insertion instrument.

9. The method of claim 1, further comprising the step of inserting the insertion instrument into the body through the incision, wherein the insertion instrument is one of a laparoscope and a thoracoscope. 5

10. The method of claim 9, wherein the target tissue is drawn into the insertion instrument prior to deployment of the constriction element therefrom. 10

11. The method of claim 1, wherein the constriction is sufficient to collapse a target portion of the lung.

12. The method of claim 1, wherein the constriction creates a neck of reduced cross-sectional area at the target portion of the lung. 15

13. The method of claim 1, wherein the constriction elements includes a plurality of individually deployable elastic bands.

14. The method of claim 1, wherein the constriction element has shape memory properties. 20

\* \* \* \* \*

专利名称(译)	肺气肿肺组织的压缩，绑扎和经皮气道结扎		
公开(公告)号	<a href="#">US8728093</a>	公开(公告)日	2014-05-20
申请号	US12/209591	申请日	2008-09-12
[标]申请(专利权)人(译)	肉酥亚历山德拉 WOOD MARK 麦金太尔JONt CLERC CLAUDE 莲娜GARY CHU MICHAEL中文		
申请(专利权)人(译)	卢梭亚历山德拉 WOOD MARK MCINTYRE JONt CLERC CLAUDE 莲娜GARY CHU MICHAEL中文		
当前申请(专利权)人(译)	BOSTON SCIENTIFIC SCIMED , INC.		
[标]发明人	ROUSSEAU ALEXANDRA WOOD MARK MCINTYRE JON T CLERC CLAUDE LEANNA GARY CHU MICHAEL S H		
发明人	ROUSSEAU, ALEXANDRA WOOD, MARK MCINTYRE, JON T. CLERC, CLAUDE LEANNA, GARY CHU, MICHAEL S. H.		
IPC分类号	A61B17/10		
CPC分类号	A61B17/12013 A61B2017/12018 A61B17/12009 A61B2017/0419		
审查员(译)	ANDERSON , GREGORY		
优先权	60/973269 2007-09-18 US		
其他公开文献	US20090076526A1		
外部链接	<a href="#">Espacenet</a> <a href="#">USPTO</a>		

#### 摘要(译)

肺减容系统包括经皮，腹腔镜或可通过胸部分离的输送元件，其包括保持在体外的控制端和插入端，当处于操作位置时，该插入端邻近肺的目标部分的外表面并且收缩元件，其可从输送元件的远端展开，以将压缩力施加到肺的目标部分的外表面，以收缩其中的至少一个气道并使肺的目标部分收缩。

