



US007537563B2

(12) **United States Patent**  
**Temple**

(10) **Patent No.:** **US 7,537,563 B2**  
(45) **Date of Patent:** **May 26, 2009**

(54) **HEATER FOR SURGICAL VIEWING INSTRUMENTS**

(76) Inventor: **John Temple**, 2442 McKinley, Chelsea, MI (US) 48118  
(\* ) Notice: Subject to any disclaimer, the term of this patent is extended or adjusted under 35 U.S.C. 154(b) by 830 days.

(21) Appl. No.: **10/827,493**

(22) Filed: **Apr. 19, 2004**

(65) **Prior Publication Data**  
US 2004/0267094 A1 Dec. 30, 2004

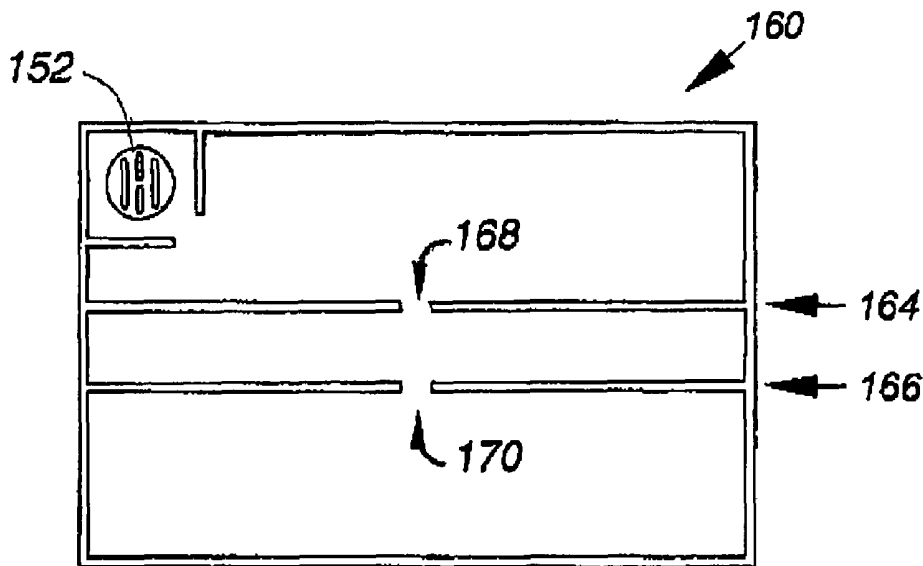
**Related U.S. Application Data**  
(60) Provisional application No. 60/463,642, filed on Apr. 17, 2003.

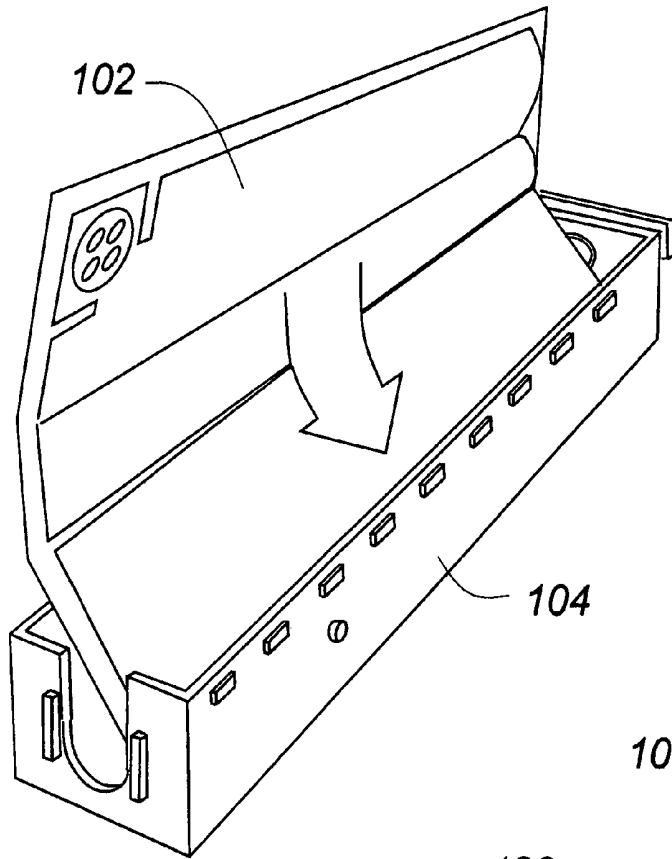
(51) **Int. Cl.**  
*A61B 1/06* (2006.01)  
(52) **U.S. Cl.** ..... 600/169; 600/101; 600/133; 126/263.04; 126/263.05; 126/263.06; 126/263.07; 126/263.08; 126/263.09; 126/263.1  
(58) **Field of Classification Search** ..... 600/101, 600/133, 169; 126/263.04-263.09  
See application file for complete search history.

(56) **References Cited**  
U.S. PATENT DOCUMENTS  
5,351,675 A \* 10/1994 Brodsky ..... 600/169  
5,549,543 A \* 8/1996 Kim, II ..... 600/169  
5,651,757 A \* 7/1997 Meckstroth ..... 600/169  
5,910,106 A \* 6/1999 Morgan et al. .... 600/169  
6,234,635 B1 \* 5/2001 Seitzinger et al. .... 359/512  
2002/0022762 A1 2/2002 Beane et al. .... 600/101  
\* cited by examiner  
*Primary Examiner*—Linda C Dvorak  
*Assistant Examiner*—Matthew J Kasztejna  
(74) *Attorney, Agent, or Firm*—Gifford, Krass, Sprinkle, Anderson & Citkowski, P.C.

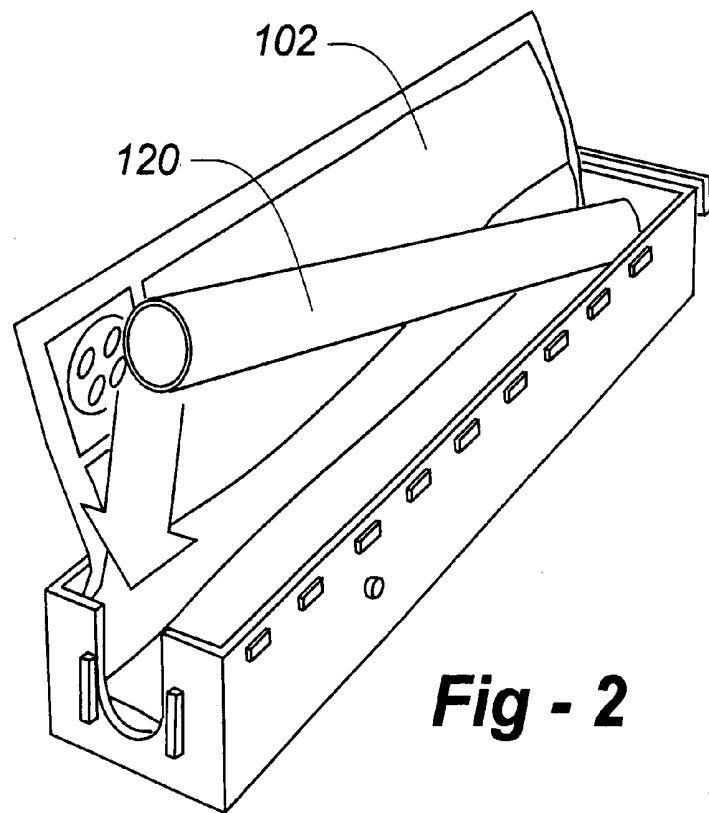
(57) **ABSTRACT**  
A system and associated method is used for warming an endoscope, laparoscope, or other such instrument to minimize fogging. The preferred embodiment comprises a pad for wrapping around an instrument, including a one or more substances operative to generate heat through an exothermic reaction; and an activation disc located around the periphery of the pad to provide for convenient user access. In the preferred embodiment, the activator is a mixture of water and sodium acetate, and the disc is made of perforated stainless steel. A housing contains the pad in sleeve form and an optional heat-conductive tube to receive the instrument around which the pad is wrapped. The pad may be partitioned.

**4 Claims, 3 Drawing Sheets**

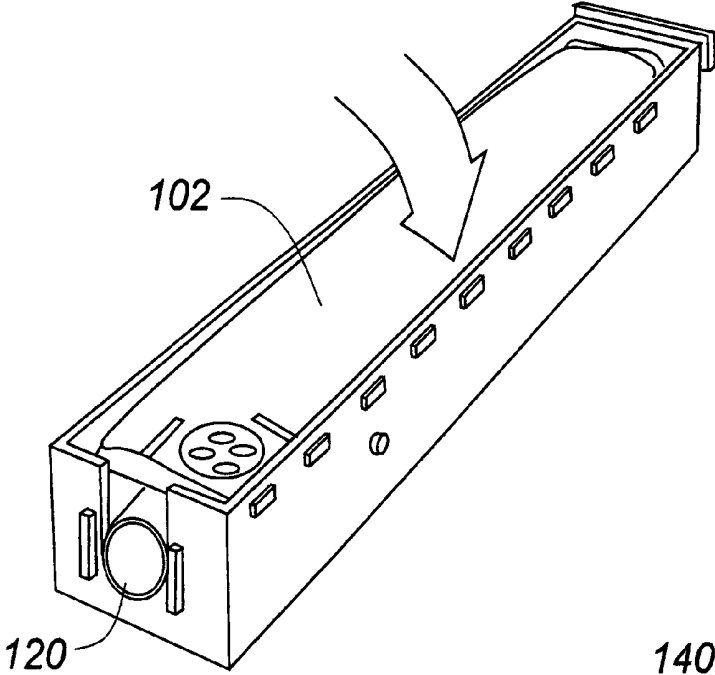




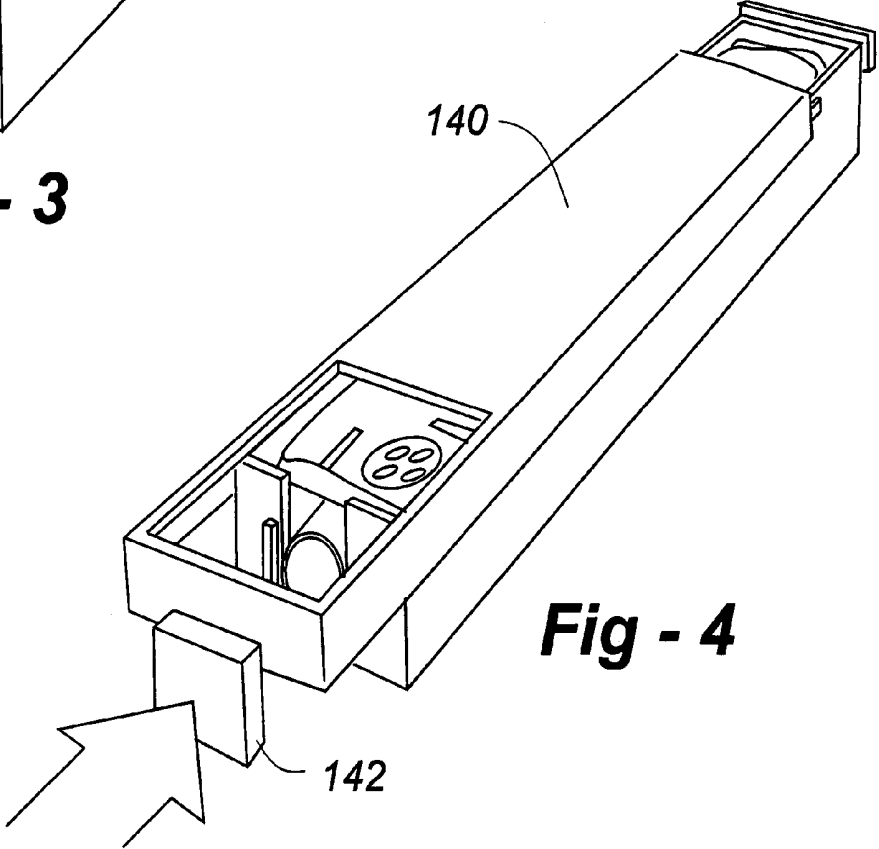
**Fig - 1**



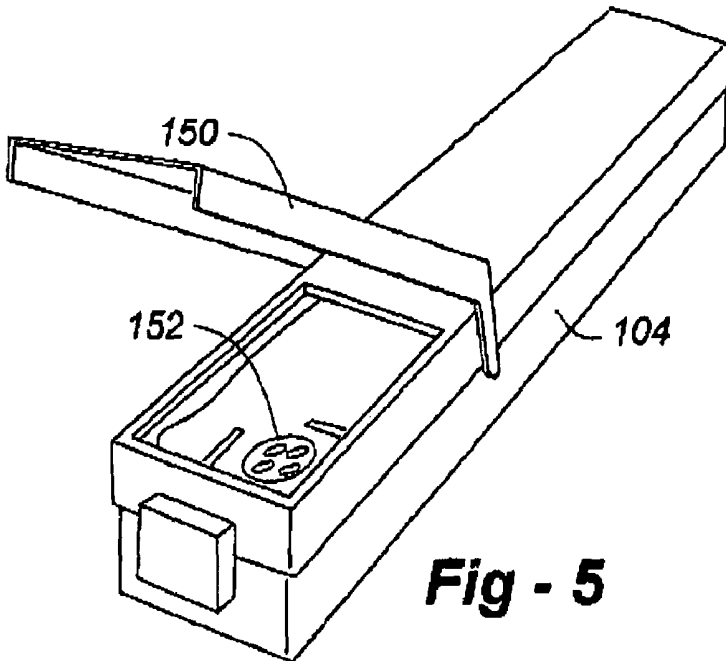
**Fig - 2**



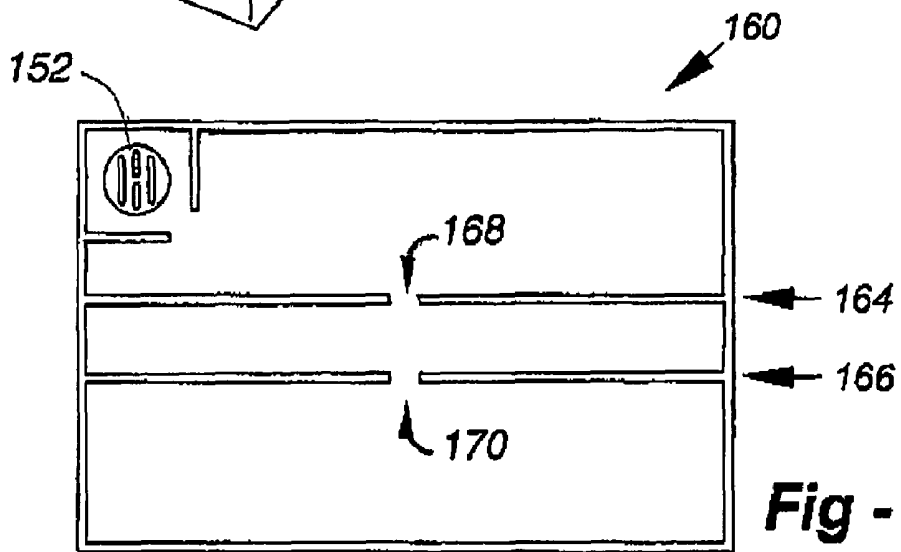
**Fig - 3**



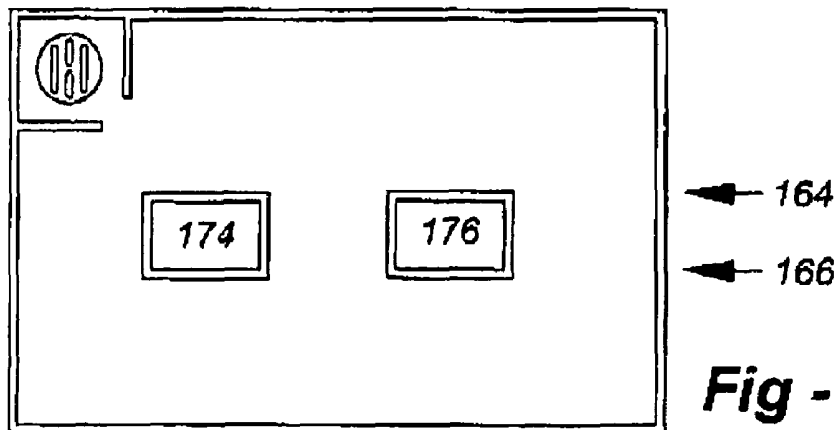
**Fig - 4**



**Fig - 5**



**Fig - 6**



**Fig - 7**

## HEATER FOR SURGICAL VIEWING INSTRUMENTS

### REFERENCE TO RELATED APPLICATION

This application claims priority from U.S. Provisional Patent Application Ser. No. 60/463,642, filed Apr. 17, 2003, the entire content of which is incorporated herein by reference.

### FIELD OF THE INVENTION

This invention relates generally to surgical instruments and supplies and, in particular, to heater for medical and surgical viewers subject to fogging.

### BACKGROUND OF THE INVENTION

In minimally invasive surgical (MIS) procedures, elongated illuminators and viewers, i.e., laparoscopes and endoscopes, are inserted through small incisions in the abdominal wall or elsewhere. The viewer is typically coupled to a video camera that shows the operating field on a monitor.

A common problem is that the lens on the viewer becomes fogged. When the viewer is inserted, the lens is typically at operating room temperature which is often much colder than room temperature. The body cavity is at body temperature and high humidity. As such, water droplets condense on the lens, obscuring the view. When the lens fogs, the surgeon must remove the instrument, clean the lens, and reinsert the instrument at which time fogging often begins again.

To address this problem, the instrument may be immersed in a warm saline bath before surgery and during cleaning. This can be time-consuming and it is difficult to control temperature to consistent, effective working temperature.

An automated approach is described in Published U.S. Patent Application 2002/0022762 A1. A lens warming and cleaning device for use with an optical surgical instrument is disclosed. The device includes a heat-conducting tube sized and shaped to receive the lens portion of the instrument, a heating element thermally coupled to an exterior of the tube, and a cleaning member disposed within the tube. The cleaning member is disposed such that when the lens portion of the instrument is inserted into the tube, the lens portion contacts the cleaning member.

The heating element comprises a flexible pad that surrounds at least a portion of the tube including the lens portion. The pad may be wrapped around tube or attached to tube using an adhesive or hook-and-loop fasteners.

In one disclosed embodiment, the heating pad includes a flexible, air-permeable outer bag that encases a chemical mixture that generates an exothermic reaction when activated. The chemical mixture can be, e.g., a mixture of iron powder, water, cellulose, vermiculite, activated carbon, and salt. Exposing the mixture to atmospheric oxygen triggers an exothermic reaction that warms the pad to a temperature of about 60° C. and sustains that temperature for about six hours.

Other types of known exothermic reaction mixtures can be used. For example, the mixture can consist of iron powder, a chloride or sulfate of a metal having a tendency of ionization greater than iron, active carbon, and water. Alternatively, the chemical mixture can be a super-cooled, supersaturated aqueous solution of sodium acetate. The pad can also employ other types of exothermic chemical reactions to generate heat, or it can include a resistance heater powered by, e.g., a battery or an external source of electricity.

The problems with this system are two-fold. First, the addition of a cleaning mechanism is all embodiments constitutes an unnecessary complication, since warming is by far the greatest need. Additionally, although "other types of exothermic chemical reactions" are mentioned in passing, activation methods and apparatus are not disclosed. Accordingly, the need remains for a less expensive yet effective endoscope/laparoscope warming system.

### SUMMARY OF THE INVENTION

This invention resides in a system and associated method for warming an endoscope, laparoscope, or other such instrument to minimize fogging. The preferred embodiment comprises a pad for wrapping around an instrument, including a one or more substances operative to generate heat through an exothermic reaction; and an activation disc located around the periphery of the pad to provide for convenient user access. In the preferred embodiment, the activator is a mixture of water and sodium acetate, and the disc is made of perforated stainless steel. A housing contains the pad in sleeve form and an optional heat-conductive tube to receive the instrument around which the pad is wrapped. The pad may be partitioned.

### BRIEF DESCRIPTION OF THE DRAWINGS

FIG. 1 is a drawing which shows the way in which a heating pad is inserted into a housing with the top cover removed;

FIG. 2 shows the way in which an internal tube is placed into the pad;

FIG. 3 is a drawing which shows how the pad is then folded over on top of the tube to completely surround it;

FIG. 4 illustrates the addition of the top cover without a hinge lid;

FIG. 5 is the drawing of a completed unit including a hinge lid;

FIG. 6 is a drawing of the preferred embodiment the pad; and

FIG. 7 is a drawing illustrating an alternative embodiment of a pad.

### DETAILED DESCRIPTION OF THE INVENTION

This invention improves upon the prior art by providing a low-cost yet effective heater for medical/surgical viewers subject to fogging, including endoscopes, laparoscopes, elongated microscopes, and so forth. Broadly, the apparatus includes a housing into which there is disposed a heating pad containing chemicals to produce heat through an exothermic reaction. The pad is rolled in the housing to create an elongated cavity in alignment with an aperture through the housing into which the instrument to be warmed is placed. In a preferred embodiment, a heat-conductive tube is also included between the rolled pad and instrument to provide for more consistent heating, and silicon acetate is used as the active ingredient in the pad, generated heat through contact with water also in the pad.

Now making reference to the drawings, FIG. 1 is an oblique representation showing the way in which pad 102 is placed into a housing 104 without a lid or hinged access panel, which will be described with reference to subsequent figures. In FIG. 2, a heat-conductive tube 120 of aluminum, stainless steel, or other suitable metal or other material is placed into the partially rolled pad 102.

In FIG. 3, the remaining portion of the pad 102 is folded over and onto the tube 120, again, without the lid or access panel being shown. In FIG. 4, the lid 140 is placed onto the

3

housing, with an access door **142** being provided in alignment with the opening of tube **120**, as shown. In FIG. **5**, a hinged lid **150** is added, allowing a user to open the lid to gain access to an activation area **152** on the pad, which will be described in further detail below.

FIG. **6** is a plan view of a preferred heating pad **160** according to the invention. The pad contains a mixture of sodium acetate and water, and, unique to the invention, a particular spot **152** is provided, including a stainless steel disc to initiate the chemical reaction. Referring back to FIG. **5**, this disc is placed on the pad so that when rolled into the housing, the area **152** is easily accessible when the hinged lid **150** is opened. Note that the pad **160** is also otherwise partitioned along lines **164** and **166** to conveniently provide fold areas for easier placement into the housing **104**. Gaps **168**, **170** facilitate fluid transfer of the mixture.

FIG. **7** illustrates an alternative design for the pad, wherein, instead of elongated seams **164** and **166**, islands **174** and **176** are provided instead, these also being conducive to folding along the same desired line.

4

I claim:

1. A system for warming an endoscope, laparoscope, or other such instrument to minimize fogging, comprising:
  - a flexible pad having a length, a width and a periphery for wrapping around the instrument, the pad including a mixture of water and sodium acetate to generate heat through an exothermic reaction;
  - an activation disc located around the periphery of the pad; and
  - one or more elongate partitions running lengthwise along the pad to establish fold lines, each partition including a gap to facilitate fluid transfer of the mixture.
2. The system of claim **1**, wherein the activation disc is made of perforated stainless steel.
3. The system of claim **1**, further including a housing to contain the pad in sleeve form into which the instrument is inserted.
4. The system of claim **1**, further including a heat-conductive tube to receive the instrument around which the pad is wrapped.

\* \* \* \* \*

专利名称(译)	用于手术观察仪器的加热器		
公开(公告)号	<a href="#">US7537563</a>	公开(公告)日	2009-05-26
申请号	US10/827493	申请日	2004-04-19
[标]申请(专利权)人(译)	TEMPLE JOHN		
申请(专利权)人(译)	TEMPLE JOHN		
[标]发明人	TEMPLE JOHN		
发明人	TEMPLE, JOHN		
IPC分类号	A61B1/06 A61B1/00 A61B1/12		
CPC分类号	A61B1/127 A61B1/128		
优先权	60/463642 2003-04-17 US		
其他公开文献	US20040267094A1		
外部链接	<a href="#">Espacenet</a> <a href="#">USPTO</a>		

摘要(译)

系统和相关方法用于加热内窥镜，腹腔镜或其他此类仪器以使雾化最小化。优选实施例包括用于包裹仪器的垫，包括一种或多种可通过放热反应产生热量的物质；以及位于垫周边的激活盘，以方便用户访问。在优选的实施方案中，活化剂是水和乙酸钠的混合物，并且圆盘由穿孔的不锈钢制成。外壳包含套筒形式的衬垫和可选的导热管，以接收围绕衬垫缠绕的器械。垫可以被分隔。

