



US 20160278763A1

(19) **United States**

(12) **Patent Application Publication**
BEAVEN MD

(10) **Pub. No.: US 2016/0278763 A1**

(43) **Pub. Date: Sep. 29, 2016**

(54) **LAPAROSCOPIC WOUND CLOSURE DEVICE**

(52) **U.S. Cl.**

(71) Applicant: **Richard B. BEAVEN MD**, Covington,
KY (US)

CPC **A61B 17/0469** (2013.01); **A61B 17/0057**
(2013.01); **A61B 2017/047** (2013.01); **A61B**
17/0482 (2013.01); **A61B 2017/00637**
(2013.01); **A61B 2017/00663** (2013.01)

(72) Inventor: **Richard B. BEAVEN MD**, Covington,
KY (US)

(57) **ABSTRACT**

(21) Appl. No.: **14/667,025**

A laparoscopic wound closure device includes an elongated body portion including a proximal end, a distal end, and a pair of vertical suture channels. Each vertical suture channel has an entrance at the proximal end and an exit near the distal end for passing a suture needle through, and travels parallel to the longitudinal axis of the body portion of the device. The vertical suture channels are designed to cause a suture needle to deflect laterally as it exits the wound closure device. The wound closure device can be an obturator or a sheath of a trocar assembly, and can be used to inject local anesthetic at the conclusion of surgery.

(22) Filed: **Mar. 24, 2015**

Publication Classification

(51) **Int. Cl.**
A61B 17/04 (2006.01)
A61B 17/00 (2006.01)

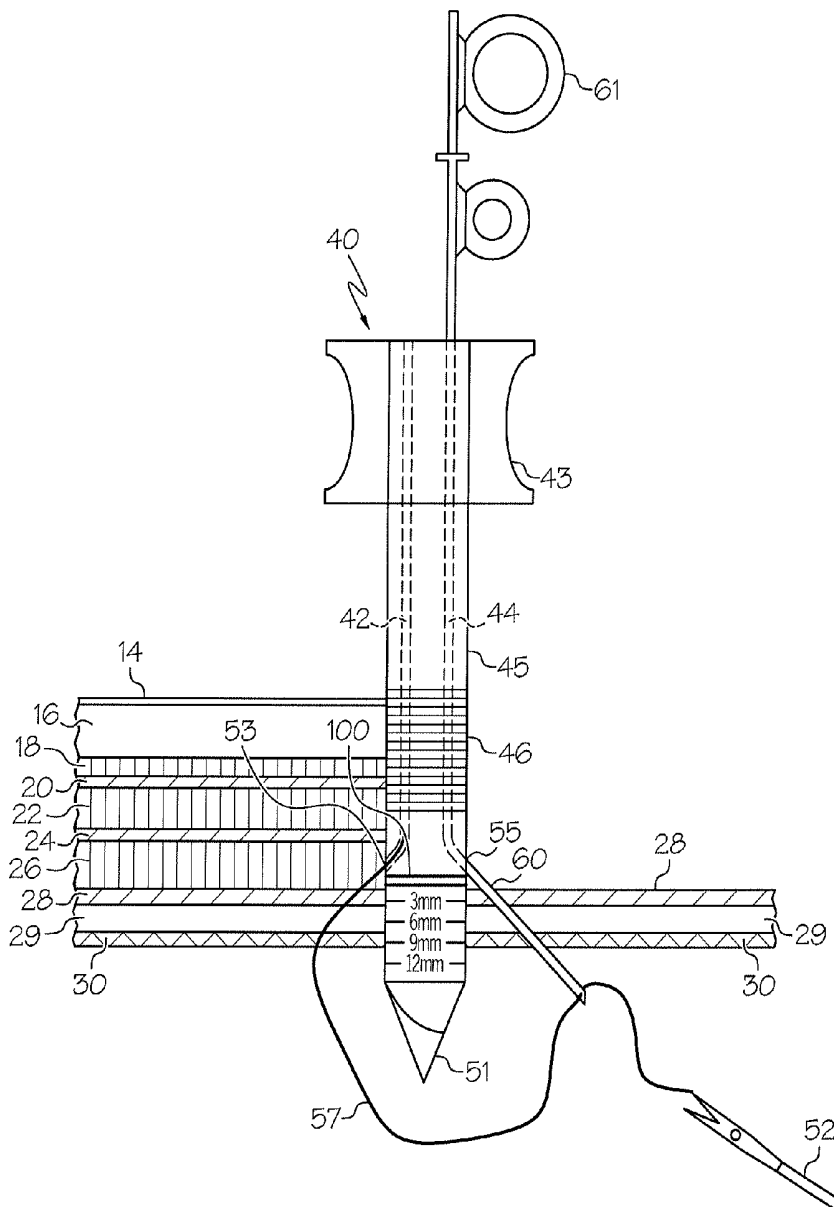

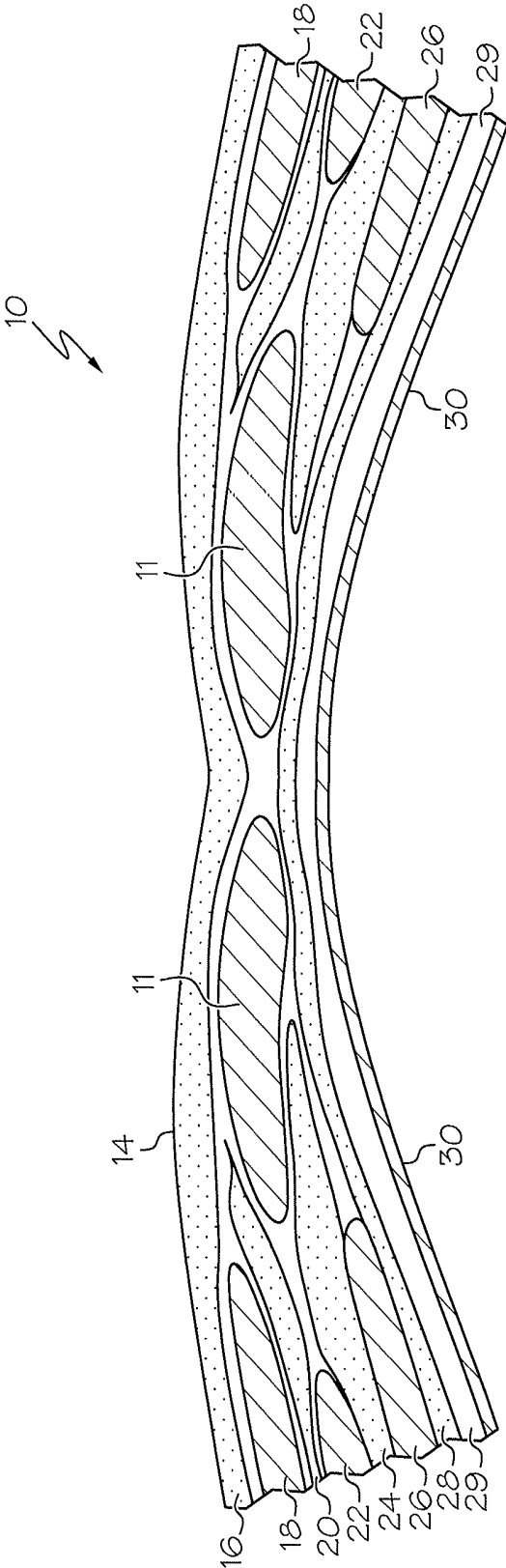

FIG. 1

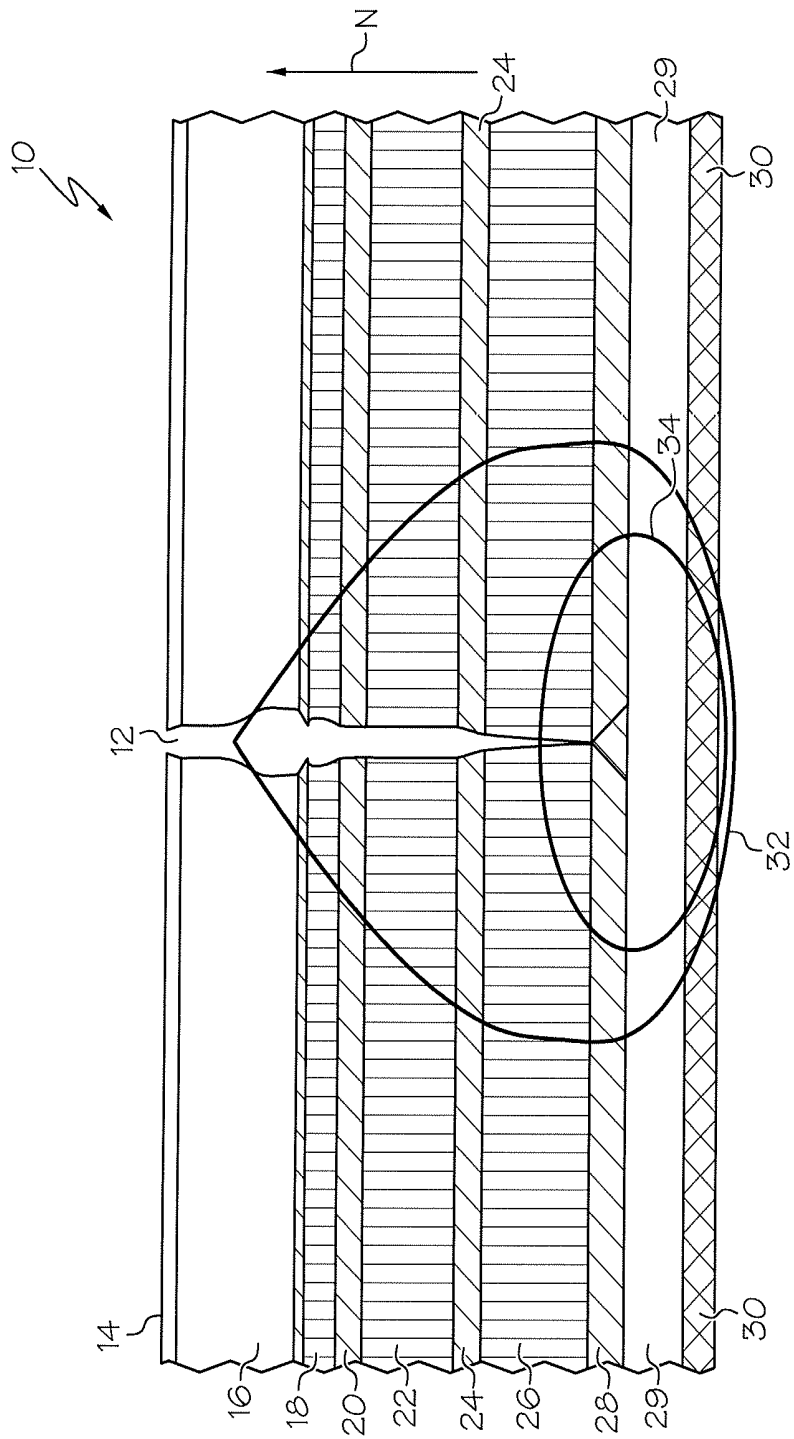

FIG. 2

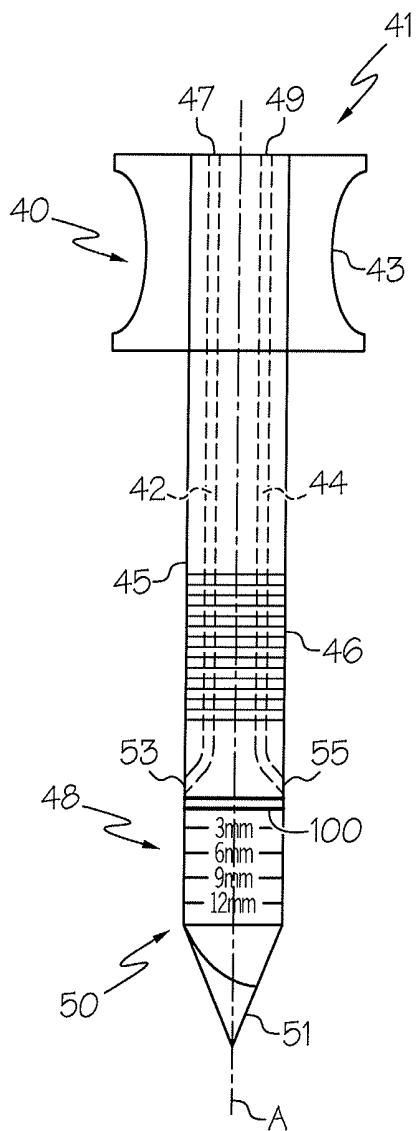

FIG. 3

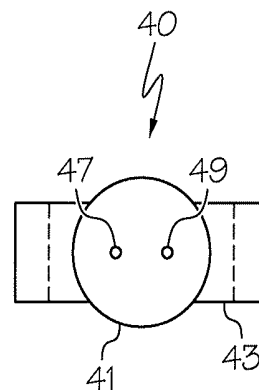

FIG. 4

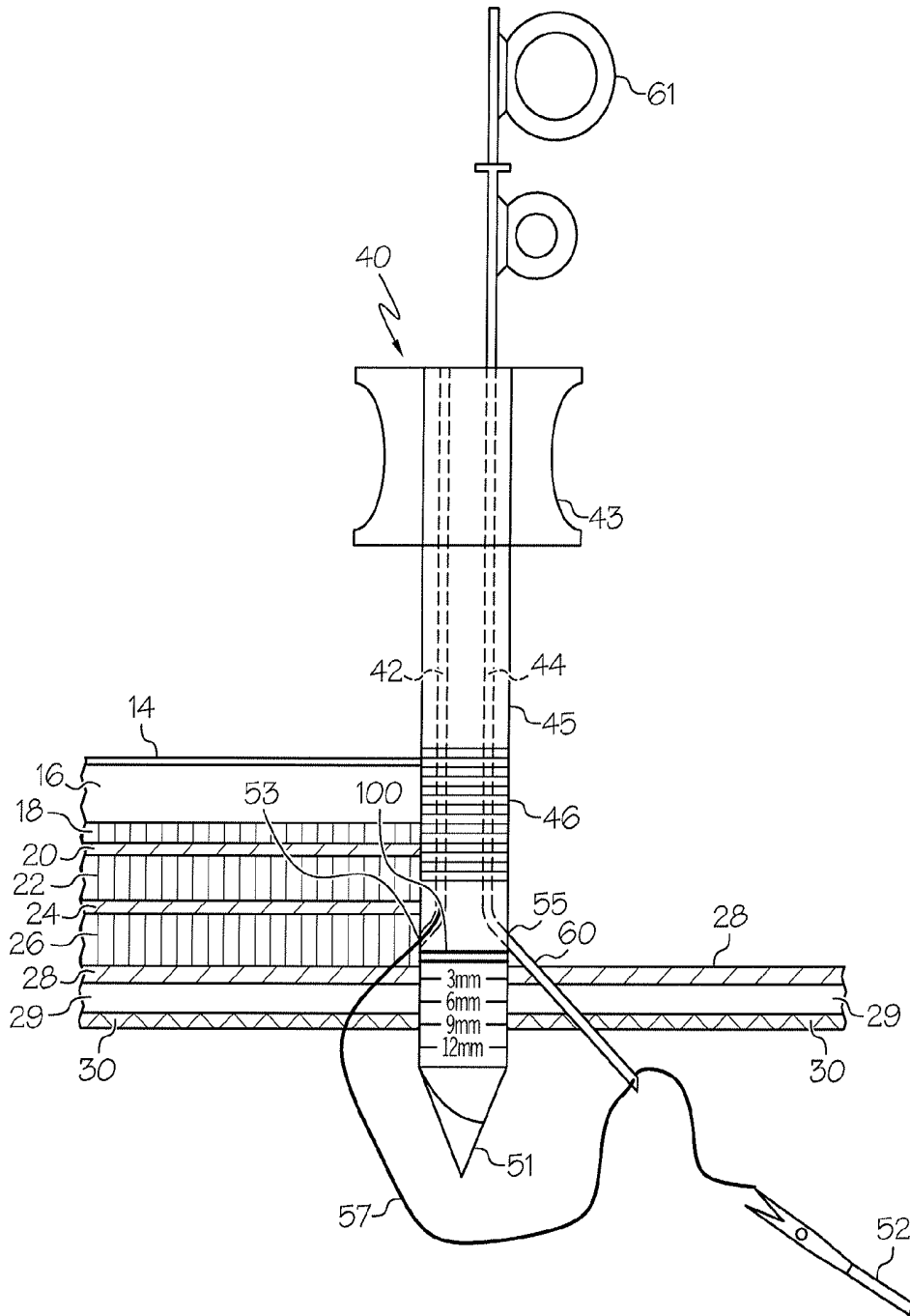

FIG. 5

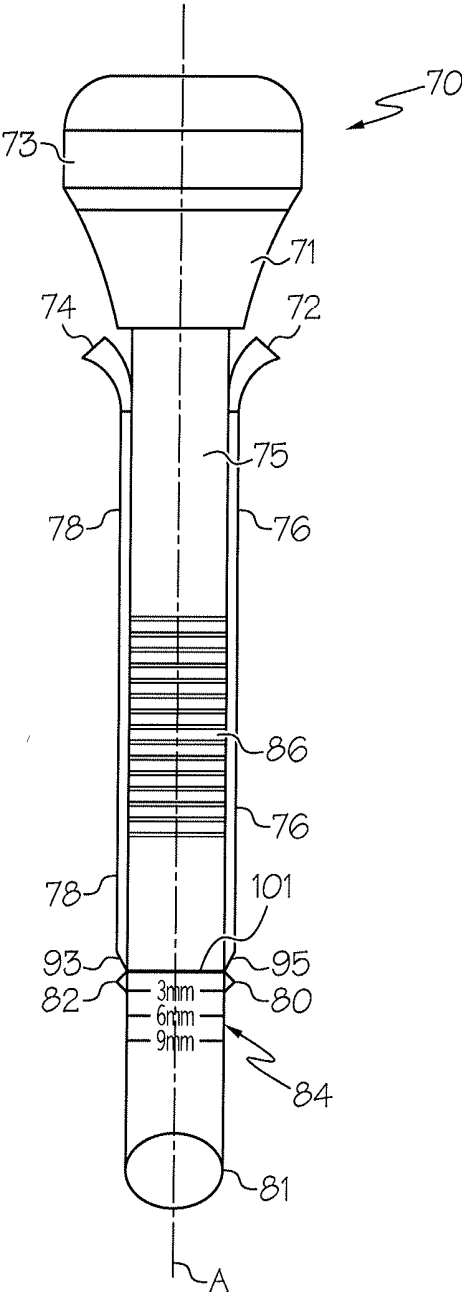

FIG. 6

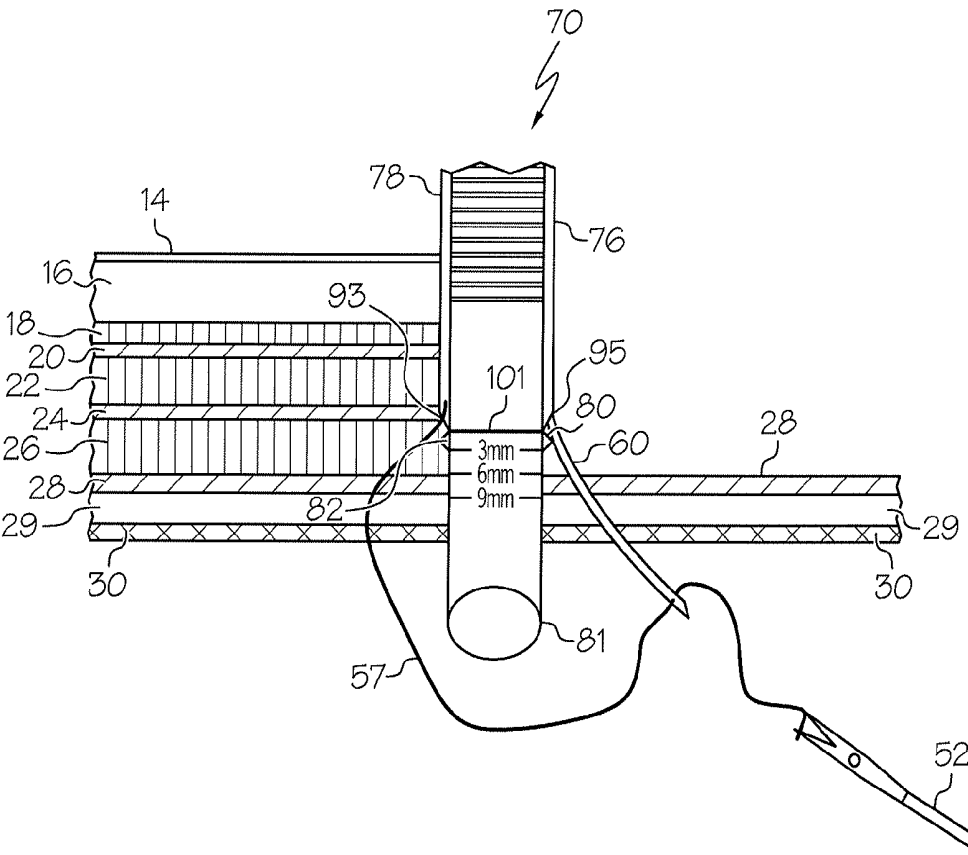

FIG. 7

LAPAROSCOPIC WOUND CLOSURE DEVICE

FIELD OF THE INVENTION

[0001] The present invention relates generally to surgical suturing devices, and more particularly to abdominal suturing devices designed for closing laparoscopic puncture wounds.

BACKGROUND OF THE INVENTION

[0002] Laparoscopic surgery, or minimally invasive surgery, has replaced many standard invasive abdominal operations that require large incisions. Current laparoscopic surgical techniques include the creation of small incisions in the lateral abdominal wall, into which one or more surgical trocar assemblies or other similar puncturing devices are placed. A trocar assembly is typically comprised of an obturator having a puncturing distal end, and a sheath or cannula which is adapted to slide over the outer diameter of the obturator. The obturator and cannula are typically used together to puncture the lateral abdominal wall to gain access to the surgical site. Once the puncture is made, the obturator is removed from the hollow cannula creating a port for introducing and removing various surgical instruments. Scissors, dissectors, retractors, and biopsy instruments can be manipulated through a plurality of surgically placed ports, together with viewing devices such as endoscopes or laparoscopes, to perform surgery or diagnostic procedures. The intraperitoneal space is typically insufflated with pressurized carbon dioxide to provide more room and better exposure for viewing the anatomy and manipulating the instruments through the ports. This technology affords the patient considerably less pain and disfigurement, and a much faster recovery.

[0003] Upon completion of the laparoscopic procedure, the remaining trocar wounds are preferably sutured to close the wound. Closure of these wounds requires proper identification and closure of the underlying abdominal wall layers of connective tissue and muscle. If these fascial layers are not properly aligned and sutured closed, bowel herniation at the port site (a "port site hernia") can result, as well as the possibility of bowel strangulation or omental trapping. Because of the limited exposure provided by the very small size of the incision and the somewhat awkward, external access to the tissues surrounding the incision, proper closure of trocar wounds can be problematic and time consuming. Successful closure is also often further compromised by patient obesity and other factors.

[0004] When closing a lateral abdominal puncture wound the suturing needle should not only secure an optimal amount of tissue to prevent herniation but also avoid sensory and motor nerves present in the more superficial layers of the lateral abdominal wall. Specifically, the iliohypogastric, ilioinguinal and thoraco-abdominal nerves typically travel along a superficial fascial plane just beneath the internal oblique muscle, but not in the deeper layers that include the transversalis fascia, pre-peritoneal fat and the peritoneum. Thus, avoiding the more superficial layers of the lateral abdominal wall and passing the suture needle to close only the deeper fascial planes can avoid nerve entrapment or post-operative neuropathy, while still sufficiently closing the wound.

[0005] Current port site closure devices, such as that disclosed by U.S. Pat. No. 6,183,485 to Thomason et al. or U.S. Pat. No. 6,743,241 to Kerr, both of which are incorporated herein by reference in their entirety, close abdominal wall laparoscopic port sites via a "mass closure" device in order to

prevent post-operative herniation. However, such mass closure devices use an approach in which the suture needle is passed indiscriminately and/or at an oblique angle through virtually all fascial layers of the lateral abdominal wall (see, e.g., FIG. 2, suture 32), which can lead to long term postoperative pain in the form of nerve entrapment, post-operative neuropathy and/or the need to surgically remove the suture.

[0006] While known abdominal wound closure devices may be useful for their intended purposes, it would be beneficial provide a wound closure device in which the suture needle avoids the superficial abdominal fascial layers containing nerves. There is also a need for an improved device and method for closing abdominal wound sites that can minimize the risk of nerve entrapment, post-operative neuropathy, puncture site herniation or other undesirable side effects of laparoscopic surgery. It would also be advantageous to provide a surgical device and method that can be utilized by surgeons having various skill levels.

SUMMARY OF THE INVENTION

[0007] Briefly stated, the wound closure device according to the various embodiments of this invention can decrease and/or eliminate the occurrence of nerve entrapment or post-operative neuropathy, while still securing an optimal amount of tissue to prevent post-operative herniation at the port site.

[0008] One aspect of the invention provides a wound closure device, the device comprising an elongated body portion including a proximal end, a distal end, and a pair of vertical suture channels, each vertical suture channel having an entrance at the proximal end and an exit near the distal end for passing a suture needle through, wherein the vertical suture channels travel parallel to the longitudinal axis of the body portion and cause the suture needle to deflect laterally as it exits the suture channel.

[0009] Another aspect of the invention provides an obturator of a trocar assembly for closing a trocar puncture wound, comprising an elongated body portion having a proximal end, a sharp distal end, and a pair of vertical suture channels, each vertical suture channel located within the body portion and having an entrance at the proximal end and an exit near the distal end for passing a suture needle through, wherein the vertical suture channels travel parallel to the longitudinal axis of the body portion and curve laterally within the body portion at the exit, thereby causing the suture needle to deflect laterally as it exits the suture channel.

[0010] Another aspect of the invention provides a sheath of a trocar assembly for closing a trocar puncture wound, comprising an elongated body portion having a proximal end, a distal end, a hollow passage extending longitudinally there-through, and a pair of vertical suture channels, each of the vertical suture channels located along the outside of the sheath and having an entrance at the proximal end and an exit near the distal end for passing a suture needle through, wherein each of the vertical suture channels travels parallel to the longitudinal axis of the body portion and includes a deflection ridge at the exit that causes the suture needle to deflect laterally as it exits the suture channel.

[0011] The disclosed embodiments of the inventive device can be used for closing a laparoscopic puncture wound according to the steps of inserting the inventive device into the puncture wound; using a suture passing device to insert a suture needle through a first of the pair of vertical suture channels; piercing the deep fascial planes and avoiding the superficial layers of the lateral abdominal wall with the suture

needle as it exits the first vertical suture channel; grasping the suture needle with a pickup instrument; passing the suture needle to the suture passing device, which has been passed through the second vertical suture channel; pulling the suture needle back through the second suture channel with the suture passing device; removing the wound closure device; and knotting the suture to close the wound.

[0012] The nature and advantages of the present invention will be more fully appreciated after reviewing the accompanying drawings, detailed description and claims.

BRIEF DESCRIPTION OF THE DRAWINGS

[0013] The accompanying drawings illustrate embodiments of the invention and, together with a general description of the invention given above, and the detailed description given below, serve to explain the principles of the invention.

[0014] FIG. 1 is a cross-sectional view depicting the anatomy of the anterior abdominal wall;

[0015] FIG. 2 is a cross-sectional side view showing two types of suture closure of a trocar wound through the lateral abdominal wall;

[0016] FIG. 3 is cross-sectional plan view of a wound closure device according to one embodiment of the present invention;

[0017] FIG. 4 is a top, plan view of the wound closure device of FIG. 3;

[0018] FIG. 5 is a cross-sectional view of the wound closure device of FIG. 3 placed in the trocar wound of FIG. 2;

[0019] FIG. 6 is a cross-sectional plan view of a wound closure device according to another embodiment of the present invention;

[0020] FIG. 7 is a cross-sectional view of the wound closure device of FIG. 6 placed in the trocar wound of FIG. 2;

DETAILED DESCRIPTION OF THE INVENTION

[0021] FIG. 1 illustrates the general anatomy of the abdominal wall 10, which is initially covered by a layer of skin 14 and fat 16 and composed of pairs of muscles, notably the rectus abdominis 11, the external oblique 18, the internal oblique 22, and the transversus abdominis 26 muscles. These muscles and their fascial attachments, notably the external oblique fascia 20, the internal oblique fascia 24 and the transversalis fascia 28, interdigitate and unite to form a sturdy, protective musculofascial layer that gives strength and support to the anterolateral abdominal wall. Below the level of the transversalis fascia 28, a layer of pre-peritoneal fat 29 precedes the peritoneum 30. The pre-peritoneal fat 29 is of varying thickness from patient to patient, ranging from zero mm to about 20 mm depending on factors such as the body fat index of the patient. The peritoneum 30 is a smooth, serous membrane that forms the lining of the intraperitoneal space within the abdominal cavity.

[0022] A trocar wound 12 that penetrates the above-noted layers of the lateral abdominal wall 10 is best seen in FIG. 2. During laparoscopic surgery a trocar wound 12 pierces the layers of the lateral abdominal wall, puncturing (in order) the skin 14, subcutaneous fat 16, the external oblique muscle 18, the external oblique fascia 20, the internal oblique muscle 22, the internal oblique fascia 24, the transversus abdominis muscle 26, the transversalis fascia 28, the pre-peritoneal fat 29 and the peritoneum 30. Sutures 32, 34 are shown, which

are placed for either a mass closure 32 according to the prior art, or a deep closure 34 according to the present invention, in order to close the wound.

[0023] The arrow indicated by N in FIG. 2 indicates the superficial fascia/muscle layers, in which the majority of large sensory and motor nerves of the lateral abdominal wall are located. These layers generally comprise the internal oblique fascia 24 and higher (i.e. generally layers 18-24. Sutures placed by prior art mass closure devices, as shown by the placement of suture 32, passes the suture needle at an oblique angle through the superficial fascia and muscle layers indicated by arrow N, putting the iliohypogastric, ilioinguinal and thoraco-abdominal nerves at risk of entrapment and/or causing post-operative neuropathy. The present invention provides an improved wound closure device for deep placement of a suture 34, in which the suture needle is first passed vertically through the wound, within a vertical passage of the inventive closure device, and exits to penetrate the deep fascial planes only (i.e. the transversus abdominis muscle and deeper), avoiding the superficial layers N of the lateral abdominal wall. FIG. 2 shows a deep suture 34 of the present invention placed through the deep fascial planes (i.e. a portion of the transversus abdominis muscle 26, the transversalis fascia 28, the pre-peritoneal fat 29, and the peritoneum 30). Isolating the deep fascial planes and placement of a deep suture 34 in this manner can decrease and/or eliminate the occurrence of nerve entrapment or post-op neuropathy, while still securing an optimal amount of tissue to prevent herniation.

[0024] One embodiment of the inventive device, as shown in FIGS. 3, 4 and 5, is a wound closure device 40 having an elongated body portion 45 including a proximal end 41 (with an ergonomic handle 43), a distal end 50 with a penetrating tip 51, and a pair of vertical suture channels, e.g. a first vertical suture channel 42 and a second vertical suture channel 44 located in and passing through the body 45 of the wound closure device 40. Each vertical suture channel 42, 44 has an entrance 47, 49 at the proximal end 41 and travels parallel to the longitudinal axis A-A of the body portion 45. As the vertical channels 42, 44 near the distal end 50 of the wound closure device they curve and exit the side of wound closure device via exits 53, 55. Exits 53 and 55 are located directly above the zero line 100 of depth markers 48, located at the distal end 50 of the device. The diameter of the body portion 45 of the wound closure device 40 should be chosen to fit the diameter of the wound 12 (see FIG. 2) created during surgery, and typically can be made to have a diameter of between 5 (five) mm and 20 (twenty) millimeters. If the wound closure device 40 is an obturator for a trocar assembly, then the diameter of the body portion 45 should be chosen to fit the diameter of the sheath of the trocar assembly.

[0025] The curve of the vertical suture channels 42, 44 at the distal end 50 of the wound closure device 40 will deflect and/or direct the suture needle laterally through the exits 53, 55. The channels 42, 44 can be curved at an angle of between 20° and 60° and preferably at an angle of between 30° and 45° from the longitudinal axis A-A of the wound closure device 40 to direct the suture needle laterally. Lateral deflection of the suture needle 60 by the channels 42, 44 in this manner causes the suture needle to take a large enough "bite" of the deepest fascial layers, i.e. the peritoneum 30, the pre-peritoneal fat 29 and the transversalis fascia 28, and optionally a deep portion of the transversus abdominis muscle 26. This approach can avoid the iliohypogastric, ilioinguinal and tho-

raco-abdominal nerves typically traveling closer to the skin surface **14**, such as in the internal oblique fascia **24** running between the internal oblique muscle **22** and transversus abdominis muscle **26**. Closing the peritoneum **30** and the transversalis fascia **28** is generally adequate for closing the puncture wound **12** and preventing the risk of herniation at the port site, nerve entrapment or post-operative neuropathy. Lateral deflection of the suture needle within the degree ranges noted above typically does not present a problem of bending the needle, since the needle can be made of a flexible metal as is known in the art.

[0026] Depth markers **48** located near the distal end **50** of the wound closure device **40** are used to determine the depth of suture placement (see FIG. 5). It is notable that the depth markers **48** do not represent how far down the suture is placed below the skin **14**, but rather the depth markers **48** measure how far the suture is placed above the level of the peritoneum **30**. The depth markers can be visualized by the surgeon via an endoscope inserted into the insufflated intraperitoneal space through a separate port. Zero line **100**, as illustrated in FIGS. 3 and 5, is a depth marker that represents essentially 0.0 millimeters (mm) from its alignment with the peritoneum **30** to the suture exits **53**, **55**, which are located directly above the zero line **100**. Thus, alignment of the zero line **100** with the peritoneum **30** will ensure that the suture needle at least passes through the peritoneum **30**.

[0027] However, as noted above, the pre-peritoneal fat layer **29** (between the peritoneum **30** and the transversalis fascia **28**) is variable in thickness from patient to patient. In obese patients, the depth markers **48** located below the zero line **100** can be placed at the level of the peritoneum **30** to ensure that the suture needle exits above the peritoneum **30** and above the layer of pre-peritoneal fat **29** to also pass through the transversalis fascia **28** and perhaps the deeper portion of the transversus abdominis muscle **26**. The depth markers can be labeled in any manner desired (i.e. mm, inches, etc.), but typically should measure up to about 20 (twenty) mm from the zero line **100**, thus allowing the surgeon to take into account the thickness of the patient's pre-peritoneal fat layer **29** and then judge how high above the peritoneum **30** the suture needle should be passed to adequately close the wound **12**.

[0028] Stability ridges **46**, as illustrated in FIGS. 3 and 5, are raised semi-circular ridges which typically protrude 1 mm to 2 mm from the outer circumference of the body portion **45**. These ridges **46** hold the wound closure device **40** in place during use by virtue of the rough surface created by the raised ridges. The stability ridges **46** therefore increase friction between the wound tissue **12** and the device **40** to keep the device from sliding up and down during wound closure.

[0029] As can be appreciated from viewing FIG. 5, a flexible suture passing device **61** (as is known in the art) can be used to pass a suture needle **60** through the vertical suture channels **42** and **44**. After the suture **57** and suture needle **60** are passed through the exit **53**, thereby penetrating the deep fascial layers on one side of the device (e.g. the left side, as shown), the suture **57** is grasped with a pickup **52** from another port and "fed" to the suture needle **60** which has been passed via the passing device **61** through exit **55** of the opposite suture channel **44**. The suture is then pulled back through the opposite suture channel and tied, with the surgical knot being placed deep into the puncture wound, generally at the level of the transversus abdominis muscle **26**. This can be accomplished by the surgeon by initially removing the device

40 from the wound **12** once the suture **57** has been passed through the deep fascia on both sides of the wound **12**. The surgeon can then tie the suture **57** into a surgical knot as the two suture ends exit the skin **14**, and then push the knot down into the deeper fascial layers. A grasper or other type of knot passing device as is known in the art can be used to help tie the suture and tuck it into the wound. Further, tying and knotting the suture at the level of the deep fascial layers, as shown by suture **34** in FIG. 2, can evert the fascial edges of the wound **12** towards the skin surface, thereby allowing the surgeon to isolate and thus better approximate the torn edges of the deep fascial layers.

[0030] One embodiment of the invention, illustrated in FIG. 6, provides a wound closure device **70** in the form of a sheath or hollow cannula. This sheath embodiment can not only be used to close the wound, but it can also serve as the "port" during the laparoscopy for insertion and manipulation of instruments. When the time comes to close the wound **12**, the surgeon can simply remove the tools and close the wound using this port. As illustrated, the wound closure device **70** has an elongated body portion **75** including a proximal end **71** (with an ergonomic handle **73**) and a hollow distal end **81**. A pair of side ports **72**, **74** form entrances at the proximal end **71** for a suture passing device, and lead to vertical suture channels **76**, **78** which run externally to the body **75** of the sheath **70**. Each vertical suture channel **76**, **78** travels parallel to the longitudinal axis A-A of the body portion **75**, but the channels end at exits **93**, **95** as they near the distal end **81** of the sheath **70**. Exits **93** and **95** are located directly above the zero line **101** of depth markers **84**, located at the distal end **81** of the device. The diameter of the body portion **75** of the wound closure device **70** should be chosen to fit the diameter of the wound **12** (see FIG. 2) created during surgery, and typically can be made to have a diameter of between 5 (five) mm and 20 (twenty) millimeters. If the wound closure device **70** doubles as a sheath/port for a trocar assembly the diameter of the body portion **75** should be chosen to fit the diameter of the obturator of the trocar assembly.

[0031] Looking at FIG. 7, lateral deflection of the suture needle **60** by the deflection ridges **80**, **82** as it passes through exits **93** or **95** causes the needle **60** to travel laterally to take a larger "bite" of the deepest fascial layers, while avoiding nerves typically traveling in the superficial abdominal layers. As noted above, avoiding the superficial layers of the lateral abdominal wall and passing the suture needle through the deeper fascial planes in this manner can prevent nerve entrapment or post-operative neuropathy, while also adequately closing the wound and preventing the risk of herniation at the port site.

[0032] The deflection ridges **80**, **82** cause the needle to curve at an angle of between 20° and 60° and preferably at an angle of between 30° and 45° from the longitudinal axis A-A of the wound closure device **70** to direct the suture needle laterally. The deflection ridges **80**, **82** can also include indentations (not shown) to ensure guiding of the suture needle laterally, and to prevent slippage of the needle anteriorly or posteriorly off of the side of the deflection ridge. For example, a semi-circular notch, score or indentation can be included on the top surface of each deflection ridge **80**, **82** to aid in lateral guidance of the flexible suture passing device **61** and the needle **60** at the exits **93**, **95** of the vertical suture channels **76**, **78**.

[0033] The zero line **101** and other depth markers **84** (see FIG. 6) located near the distal end **81** of the wound closure

device are used to determine the depth of suture placement (see FIG. 7). It is notable that the depth markers do not represent how far down the suture is placed below the skin, but rather the depth markers 84 measure how far the suture is placed above the level of the peritoneum 30. The depth markers can be visualized by the surgeon via an endoscope inserted into the insufflated intraperitoneal space through a separate port. Zero line 101, as illustrated in FIGS. 6 and 7, is a depth marker that represents essentially 0.0 millimeters (mm) from its alignment with the peritoneum 30 to the suture exits 93, 95, which are located directly above the zero line 101. Thus, alignment of the zero line 101 with the peritoneum 30 will ensure that the suture needle at least passes through the peritoneum 30. However, as noted above, the depth markers 84 located beneath the zero line 101 on the device 70 can be placed at the level of the peritoneum 30 to ensure that the suture needle exits above the peritoneum 30 and above the layer of pre-peritoneal fat 29 to also pass through the transversalis fascia 28 and perhaps the deeper portion of the transversus abdominis muscle 26.

[0034] Stability ridges 86, as illustrated in FIG. 6, are raised semi-circular ridges which typically protrude 1 mm to 2 mm from the outer circumference of the body portion 75. These ridges 86 hold the wound closure device 70 in place during use by virtue of the rough surface created by the raised ridges. The stability ridges 86 therefore increase friction between the wound tissue 12 and the device 70 to keep the device from sliding up and down, both during use as a “port” during the procedure and during wound closure.

[0035] As can be appreciated from viewing FIG. 7, a suture needle 60 can be passed initially through a first vertical suture channel, such as suture channel 78, using a flexible suture passing device (e.g. 61, as seen in FIG. 5). After the suture 57 and suture needle 60 are passed through the exit 93, thereby penetrating the deep fascial layers on one side of the device (e.g. the left side, as shown), the suture 57 is grasped with a pickup 52 from another port and “fed” to the suture needle 60 which has been passed through exit 95 of the opposite suture channel 76. The suture is then pulled back through the opposite suture channel 76 and tied, with the surgical knot being placed deep into the puncture wound, generally at the level of the transversus abdominis muscle 26. This can be accomplished as described above.

[0036] The various embodiments of the inventive wound closure device disclosed herein can be manufactured as a separate surgical wound closure device 40, 70 inserted specifically for closure of the puncture wound, or it can be part of a trocar assembly, such as an obturator 40 (FIG. 3) or a sheath 70 (FIG. 6) of a trocar assembly that can be used during the surgery as well as during closure. The various embodiments of the wound closure device disclosed herein can also be used to inject an analgesic or anesthetic medication at the conclusion of the surgery, as the assembly is withdrawn from the incision. After suturing is completed, a spinal needle can be introduced via the exits 53, 55 of the vertical suture channels 42, 44 of the obturator 40 (see FIGS. 3-5), and/or the exits 93, 95 of the vertical suture channels 76 and 78 of the sheath 70 (see FIGS. 6 and 7). Medication such as local anesthetic can be placed into the tissues immediately affected by the trocar wound/tract, including punctured surfaces of the skin 14, external oblique muscle 18, the external oblique fascia 20, the internal oblique muscle 22, the internal oblique fascia 24, the transversus abdominis muscle 26, the transversalis fascia 28, the pre-peritoneal fat 29 and the peritoneum 30. Medication

can be injected by needle and syringe to the surgical wound site via the vertical suture channels, beginning in the deeper tissues and ending at the skin surface as the surgeon removes the wound closure device 40, 70 from the wound 12.

[0037] In this manner, analgesic can be applied to the surgical wound site via the vertical suture channels as the inventive device is removed at the conclusion of surgery, so that the local anesthetic is at maximum strength at the “actual” surgical site immediately post-operatively, and not at an “intended site” prior to incision and trocar placement, as is currently typically performed. The inventive device can therefore provide the ability to place post-operative analgesic or anesthetic medication where and when it is needed most. Placing analgesics prior to incision can lead to its application in the wrong place, with such early placement resulting in metabolism of the analgesic during the procedure, thereby lessening any post-operative pain relief.

[0038] The inventive device allows the suture to bypass and thus not incorporate the superficial layers of the lateral abdominal wall in the wound closure. The lateral diversion of the suture with a flexible suture passing device does not occur until the suture reaches the deeper layers of the abdominal wall. Such deep placement of the suture allows the surgeon to close only the deepest layers of the lateral abdominal wall in a specific manner, so as to avoid the nerves traveling in the more superficial layers. The depth markers are incorporated at the distal end of the device allow the surgeon to judge how far above the peritoneal surface the suture can be placed to compensate for patients having variable degrees of pre-peritoneal fat.

[0039] While the present invention has been illustrated by the description of particular embodiments in considerable detail, it is not intended to restrict or limit the scope of the appended claims to such detail. Additional advantages and modifications will be readily apparent to those skilled in the art without departing from the concept or scope of the invention.

What is claimed is:

1. A wound closure device, the device comprising an elongated body portion including a proximal end, a distal end, and a pair of vertical suture channels, each vertical suture channel having an entrance at the proximal end and an exit near the distal end for passing a suture needle through, wherein the vertical suture channels travel parallel to the longitudinal axis of the body portion and cause the suture needle to deflect laterally as it exits the suture channel.

2. The device of claim 1, wherein the wound closure device is an obturator for a trocar assembly, and wherein each vertical suture channel is located within the body portion of the obturator and curves laterally at the exit, thereby causing the suture needle to deflect laterally as it exits the suture channel.

3. The device of claim 1, wherein the device is a sheath for a trocar assembly, the sheath including a hollow passage extending longitudinally therethrough, and wherein each of the vertical suture channels are located along the outside of the sheath and include a deflection ridge at the exit that causes the suture needle to deflect laterally as it exits the suture channel.

4. The device of claim 3, wherein each of the vertical suture channels includes a side port forming the entrance at the proximal end.

5. The device of claim 1, further comprising stability ridges along the exterior of the body portion for holding the device in place during use.

6. The device of claim 1, further comprising depth markers located at the distal end for determining the placement of the suture above the level of the peritoneum.

7. An obturator of a trocar assembly for closing a trocar puncture wound, comprising an elongated body portion having a proximal end, a sharp distal end, and a pair of vertical suture channels, each vertical suture channel located within the body portion and having an entrance at the proximal end and an exit near the distal end for passing a suture needle through, wherein the vertical suture channels travel parallel to the longitudinal axis of the body portion and curve laterally within the body portion at the exit, thereby causing the suture needle to deflect laterally as it exits the suture channel.

8. The device of claim 7, further comprising stability ridges along the exterior of the body portion for holding the device in place during use.

9. The device of claim 7, further comprising depth markers located at the distal end for determining the placement of the suture above the level of the peritoneum.

10. A sheath of a trocar assembly for closing a trocar puncture wound, comprising an elongated body portion having a proximal end, a distal end, a hollow passage extending longitudinally therethrough, and a pair of vertical suture channels, each of the vertical suture channels located along the outside of the sheath and having an entrance at the proximal end and an exit near the distal end for passing a suture needle through, wherein each of the vertical suture channels travels parallel to the longitudinal axis of the body portion and includes a deflection ridge at the exit that causes the suture needle to deflect laterally as it exits the suture channel.

11. The device of claim 10, wherein each of the vertical suture channels includes a side port forming the entrance at the proximal end.

12. The device of claim 10, further comprising stability ridges along the exterior of the body portion for holding the device in place during use.

13. The device of claim 10, further comprising depth markers located at the distal end for determining the placement of the suture above the level of the peritoneum.

14. A method for closing a laparoscopic puncture wound, comprising the steps of:

- a) inserting the wound closure device of claim 1 into the puncture wound;
- b) using a suture passing device to insert a suture needle through a first of the pair of vertical suture channels;
- c) piercing the deep fascial planes and avoiding the superficial layers of the lateral abdominal wall with the suture needle as it exits the first vertical suture channel;
- d) grasping the suture needle with a pickup instrument;
- e) passing the suture needle to the suture passing device, which has been passed through the second vertical suture channel;
- f) pulling the suture needle back through the second suture channel with the suture passing device;
- g) removing the wound closure device; and
- h) knotting the suture to close the wound.

15. The method of claim 14, wherein step (a) includes inserting the obturator of claim 2.

16. The method of claim 14, wherein step (a) includes inserting the sheath of claim 3.

17. The method of claim 14, further comprising the step of injecting an analgesic or anesthetic medication via the vertical suture channels as the device is removed from the wound.

* * * * *

专利名称(译)	腹腔镜伤口闭合装置		
公开(公告)号	US20160278763A1	公开(公告)日	2016-09-29
申请号	US14/667025	申请日	2015-03-24
[标]申请(专利权)人(译)	比文MD RICHARD B		
申请(专利权)人(译)	比文MD , RICHARD B.		
[标]发明人	BEAVEN MD RICHARD B		
发明人	BEAVEN MD, RICHARD B.		
IPC分类号	A61B17/04 A61B17/00		
CPC分类号	A61B17/0469 A61B17/0057 A61B2017/00663 A61B17/0482 A61B2017/00637 A61B2017/047 A61B17/3417 A61B17/3421 A61B17/3468 A61B2017/3445 A61B2090/062		
其他公开文献	US9668725		
外部链接	Espacenet USPTO		

摘要(译)

腹腔镜伤口闭合装置包括一个细长的本体部分包括近端，远端，和一对垂直缝合通道。每个垂直缝线通道具有在近端的入口和用于使缝合针通过靠近远端的出口，以及行进平行于该装置的主体部分的纵向轴线。垂直缝合通道被设计成导致缝合针侧向偏转，因为它离开伤口闭合装置。伤口闭合装置可以是闭孔或套管针组件的外皮，并且可用于在外科手术结束时注入局部麻醉剂。

