



US 20140276907A1

(19) **United States**
(12) **Patent Application Publication**
NERING et al.

(10) **Pub. No.: US 2014/0276907 A1**
(43) **Pub. Date: Sep. 18, 2014**

(54) **LAPROSCOPIC INSTRUMENT DEPTH STOP**
(71) Applicants: **ROBERT NERING**, Stockton, NJ (US);
Elias N. Shalhoub, Cranston, RI (US)

(52) **U.S. Cl.**
CPC **A61B 17/320016** (2013.01)
USPC **606/110**

(72) Inventors: **ROBERT NERING**, Stockton, NJ (US);
Elias N. Shalhoub, Cranston, RI (US)

(57) **ABSTRACT**

(73) Assignee: **Ethicon, Inc.**, Somerville, NJ (US)

Disclosed is an infinitely adjustable depth stop for a laparoscopic instrument having a shaft, the depth stop including a first component having a first annular space adapted to allow the shaft to be fitted therethrough. The first annular space has a reducible diameter and an interference surface against which the shaft may be fitted. Upon reduction of the reducible diameter, the interference surface frictionally engages the shaft to arrest relative movement of the depth stop along the shaft. The frictional engagement may be along a curve, a spiral curve, or an area. Means are also provided to reopen the reducible diameter to release the depth stop.

(21) Appl. No.: **13/798,664**

(22) Filed: **Mar. 13, 2013**

Publication Classification

(51) **Int. Cl.**
A61B 17/32 (2006.01)

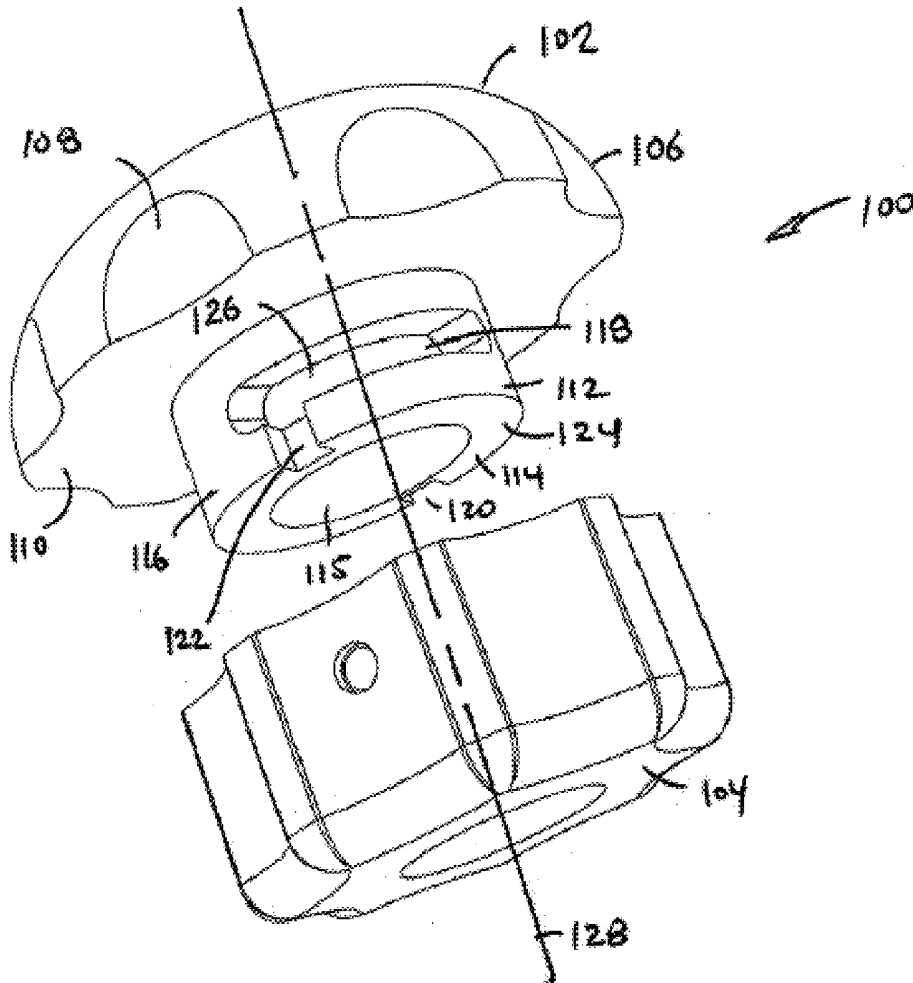

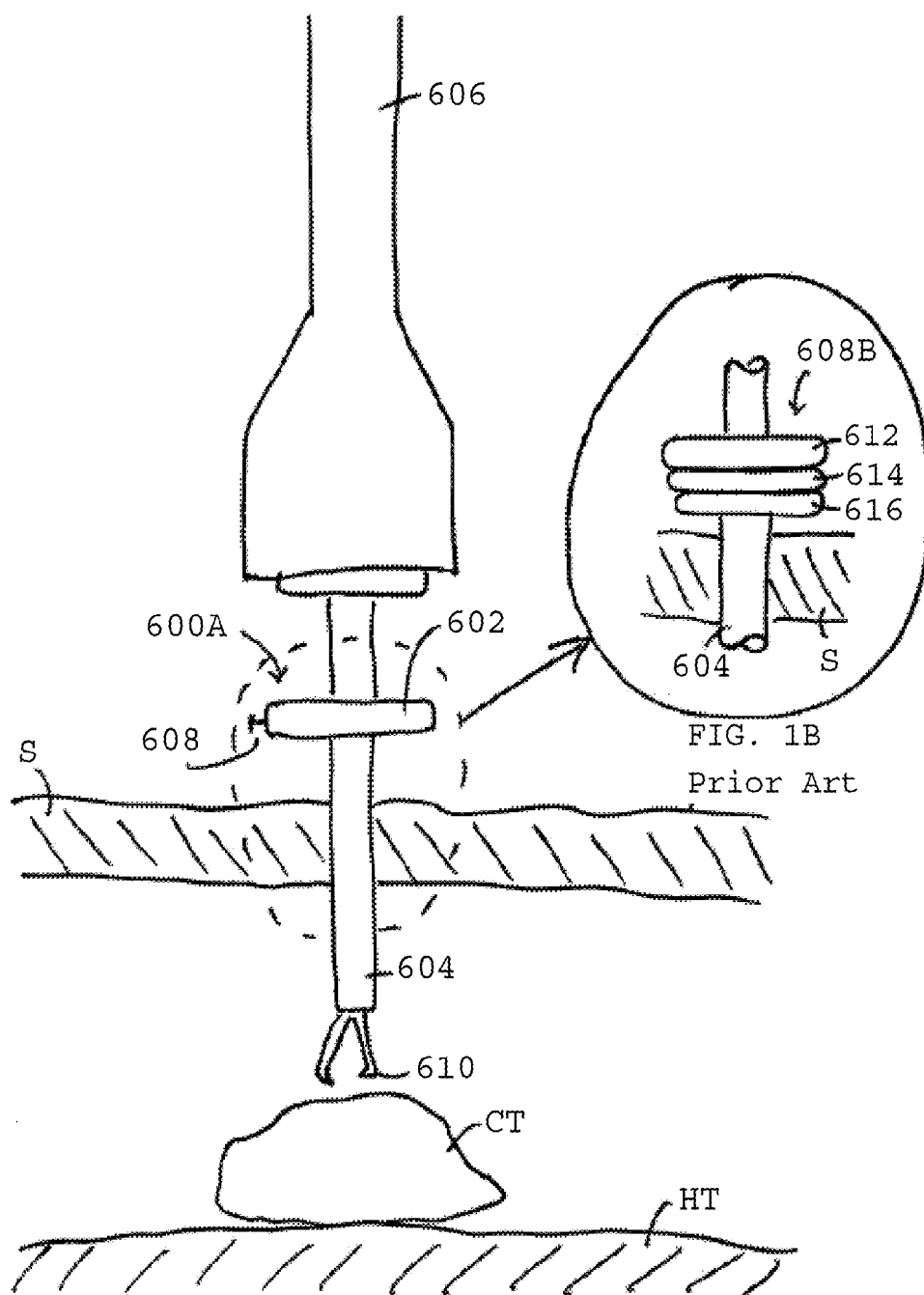

FIG. 1A
Prior Art

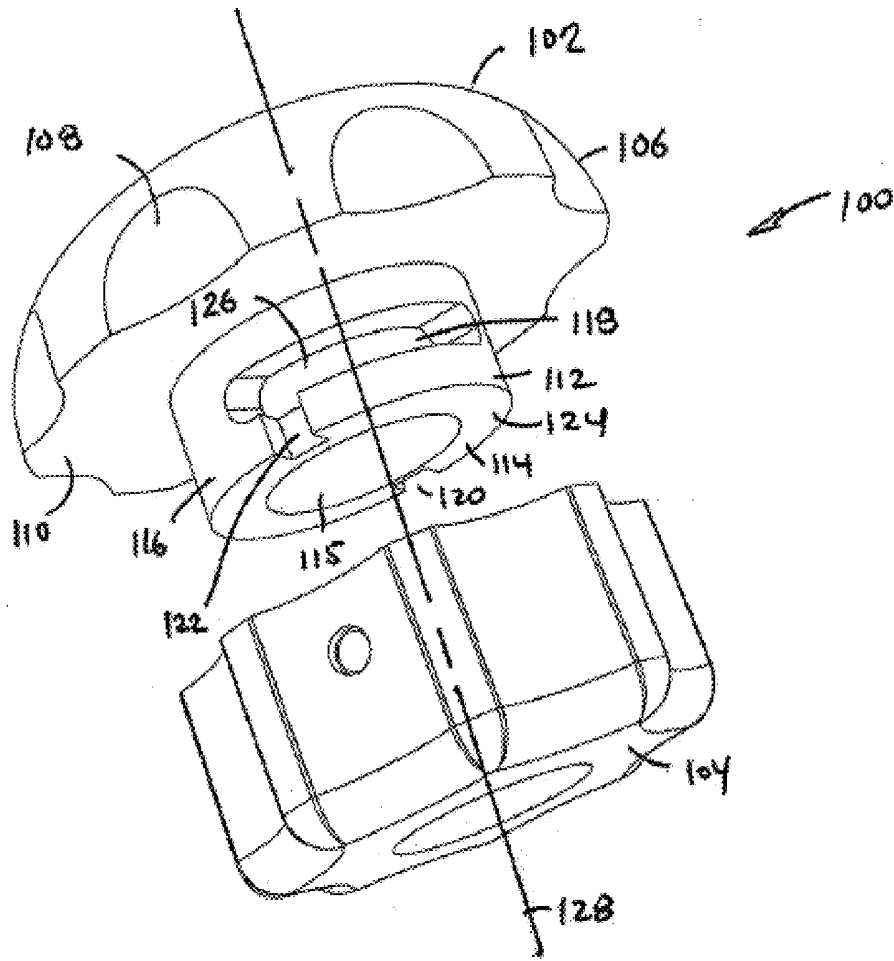

FIG. 2A

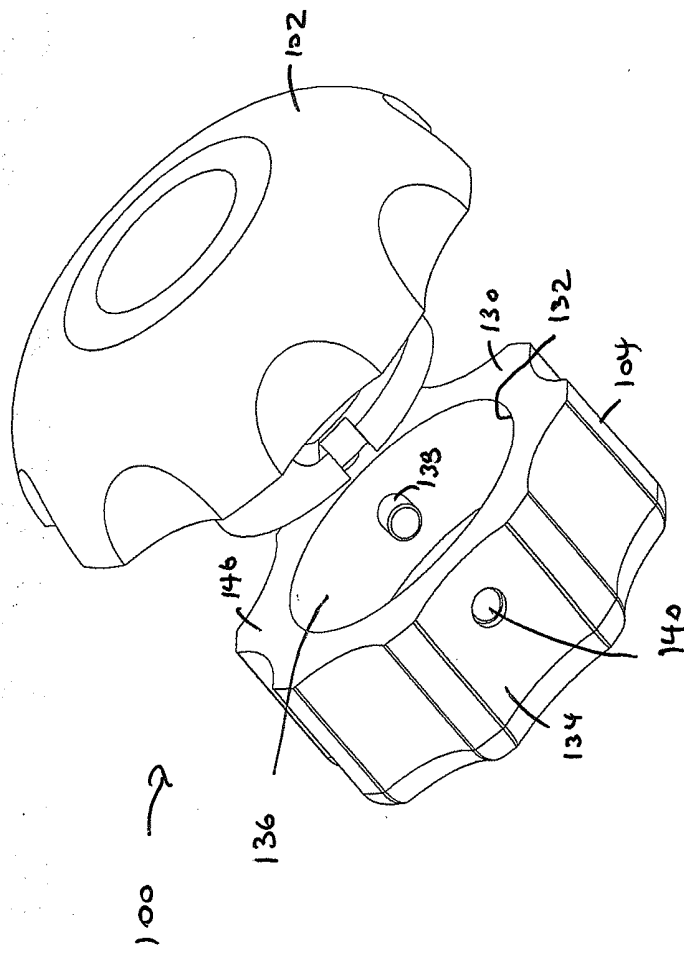

Fig. 2B

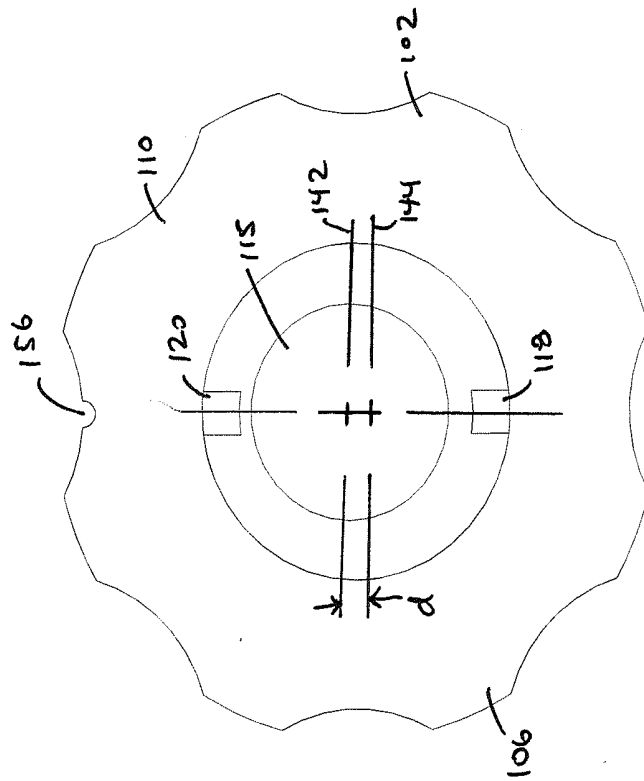

Fig. 2C

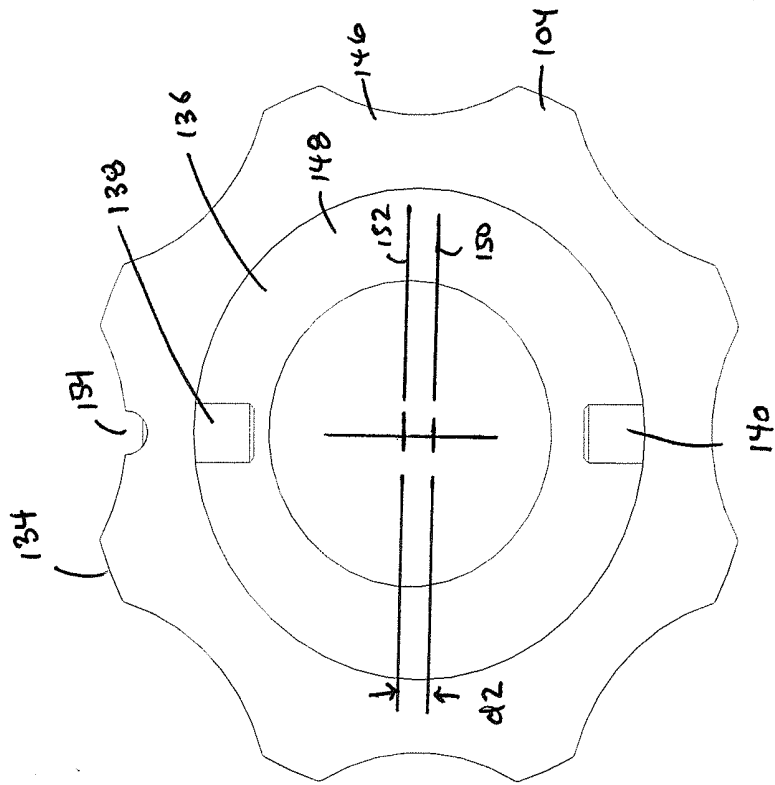

FIG. 2D

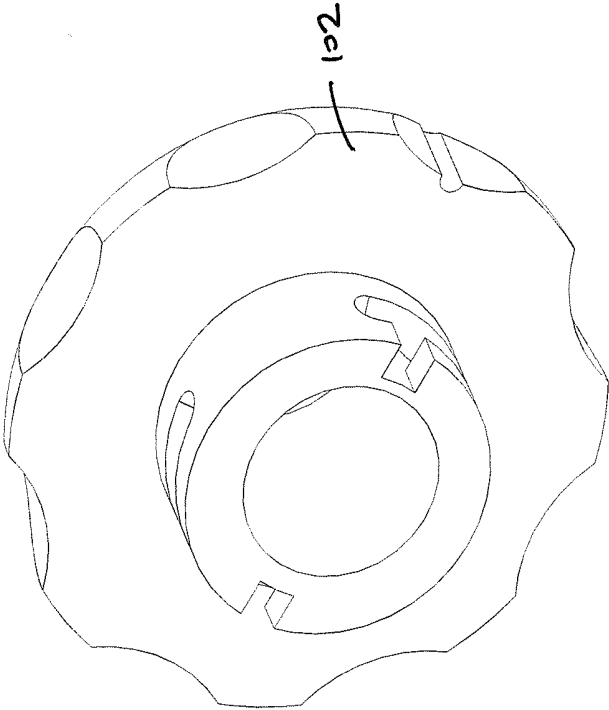

Fig. 2E

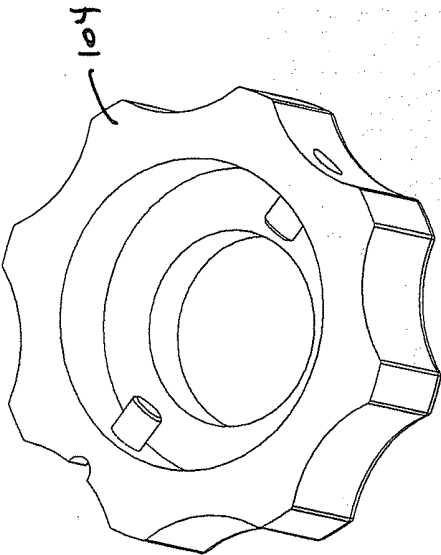

FIG. 2F

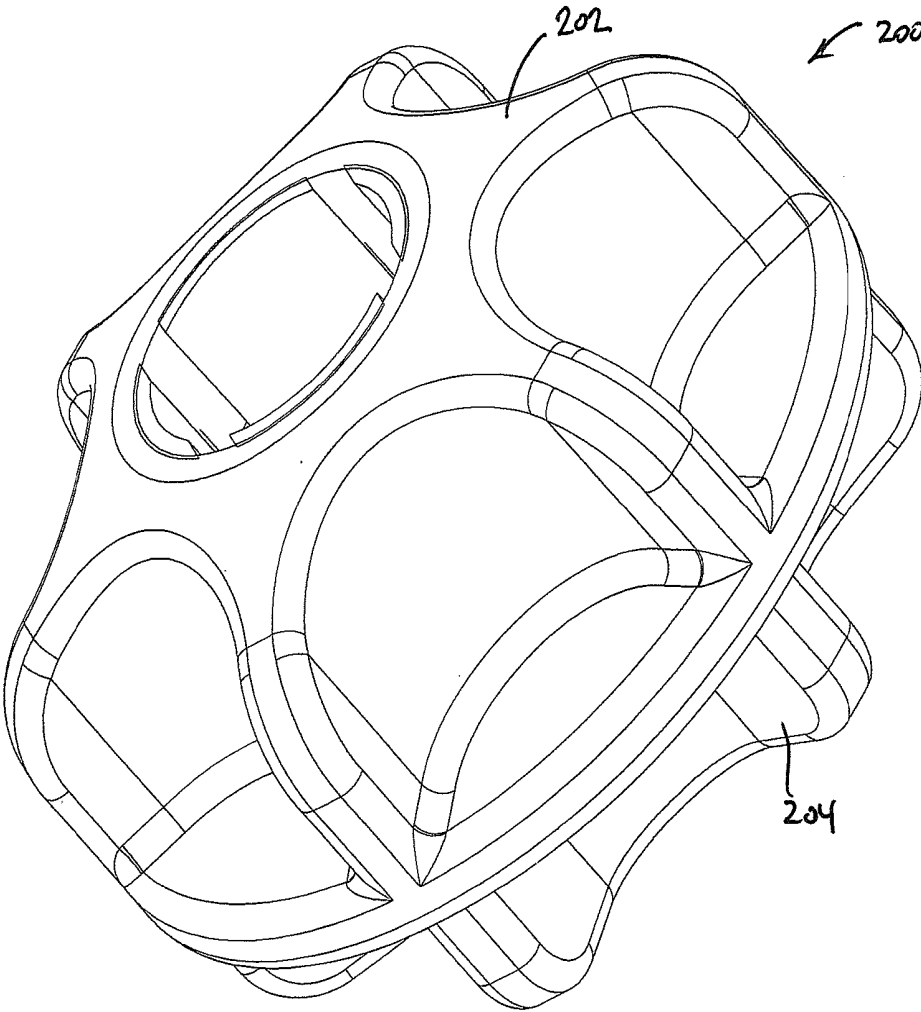

FIG. 3A

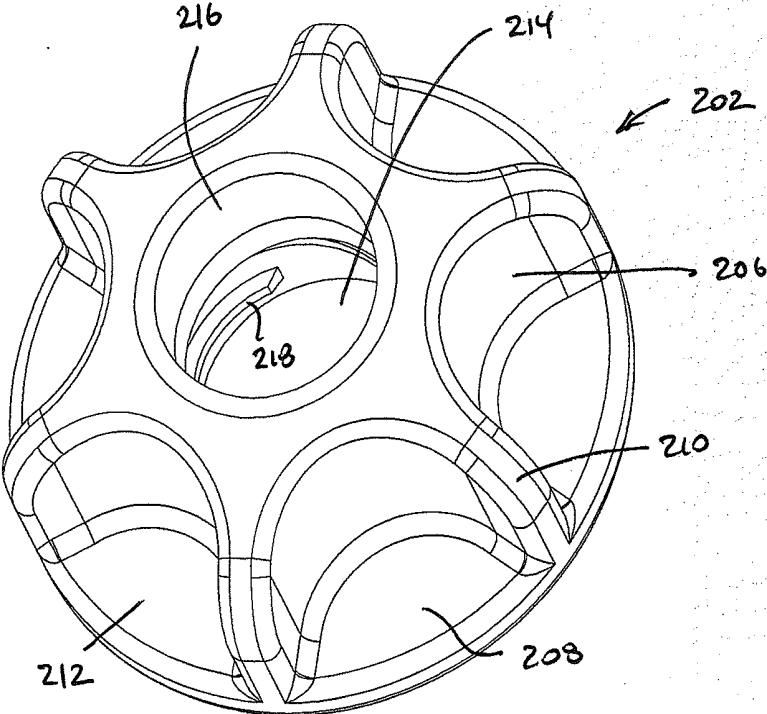

FIG. 3B

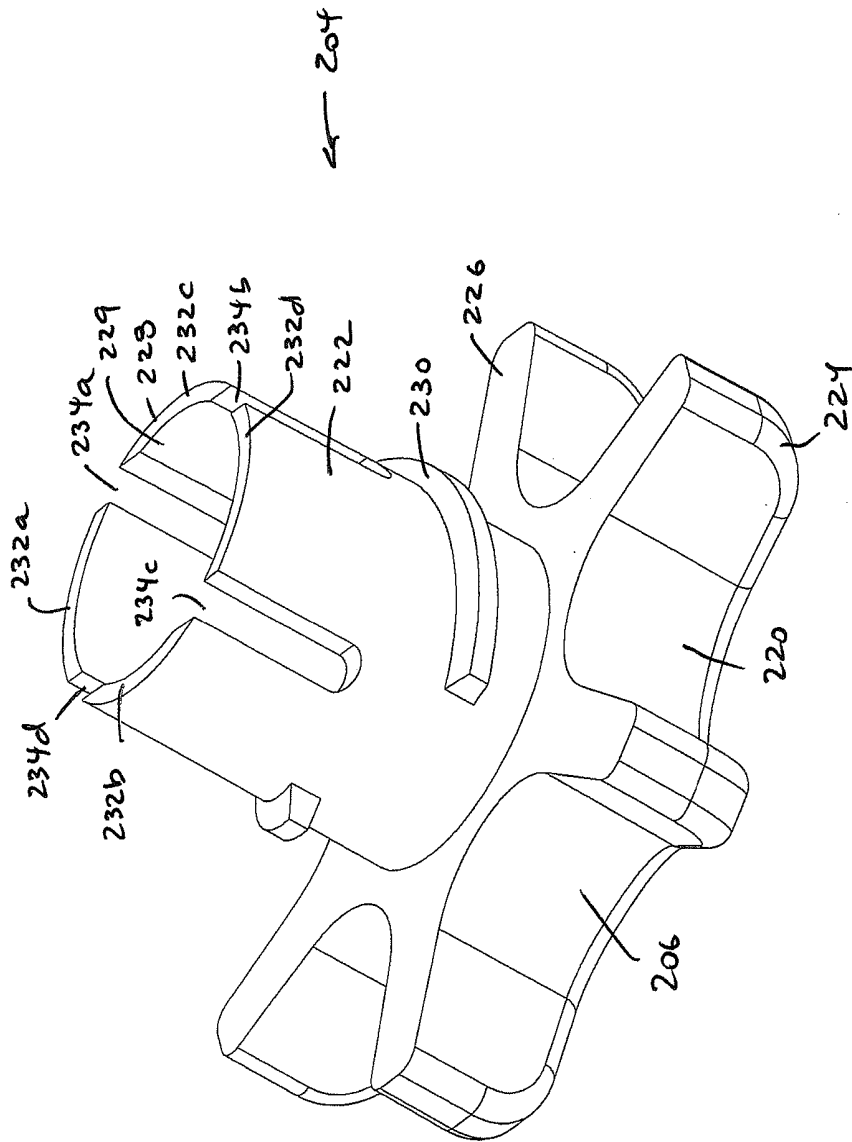

FIG. 3C

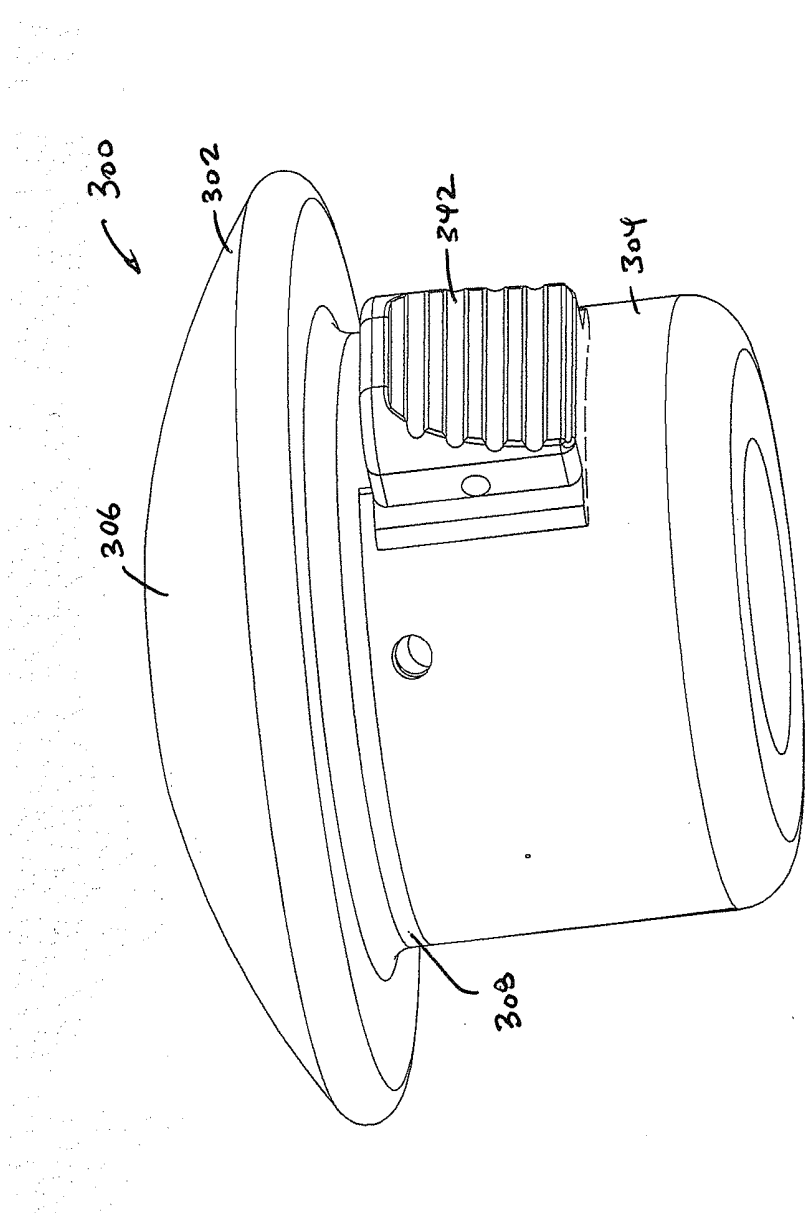

FIG. 4A

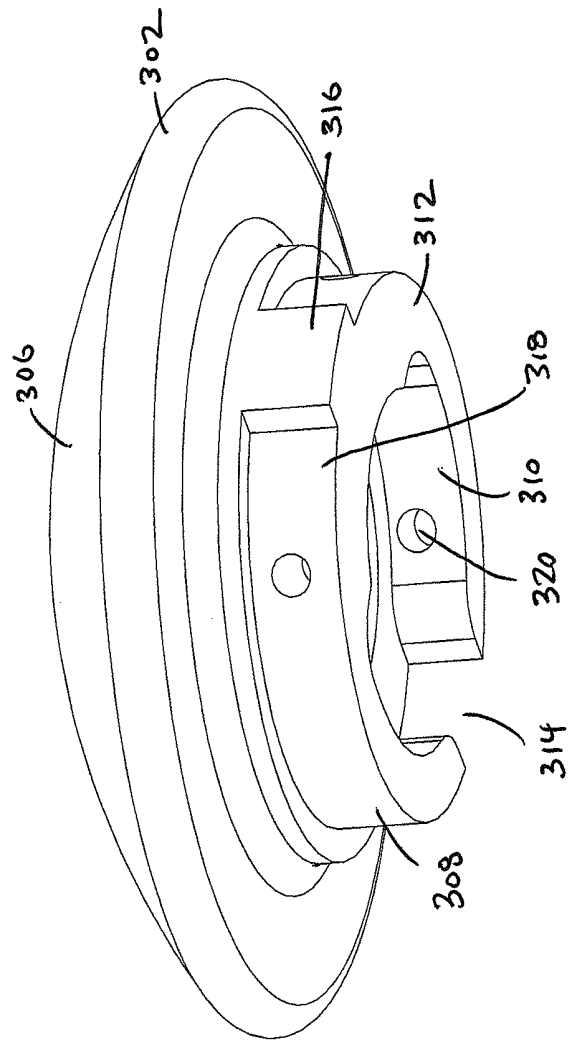

FIG. 4B

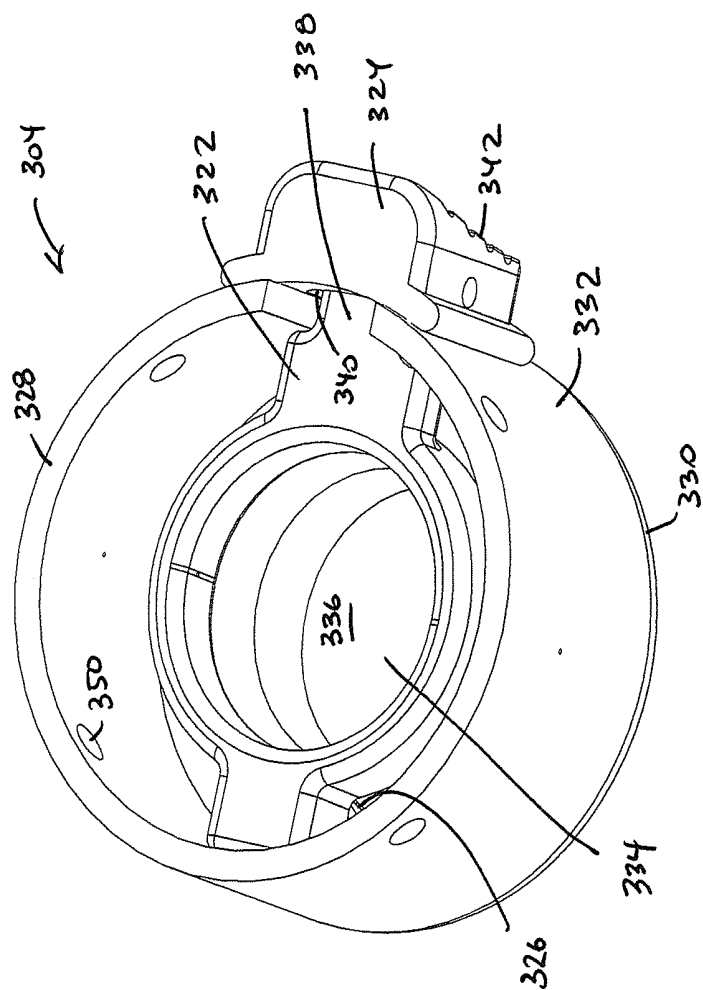

Fig. 4C

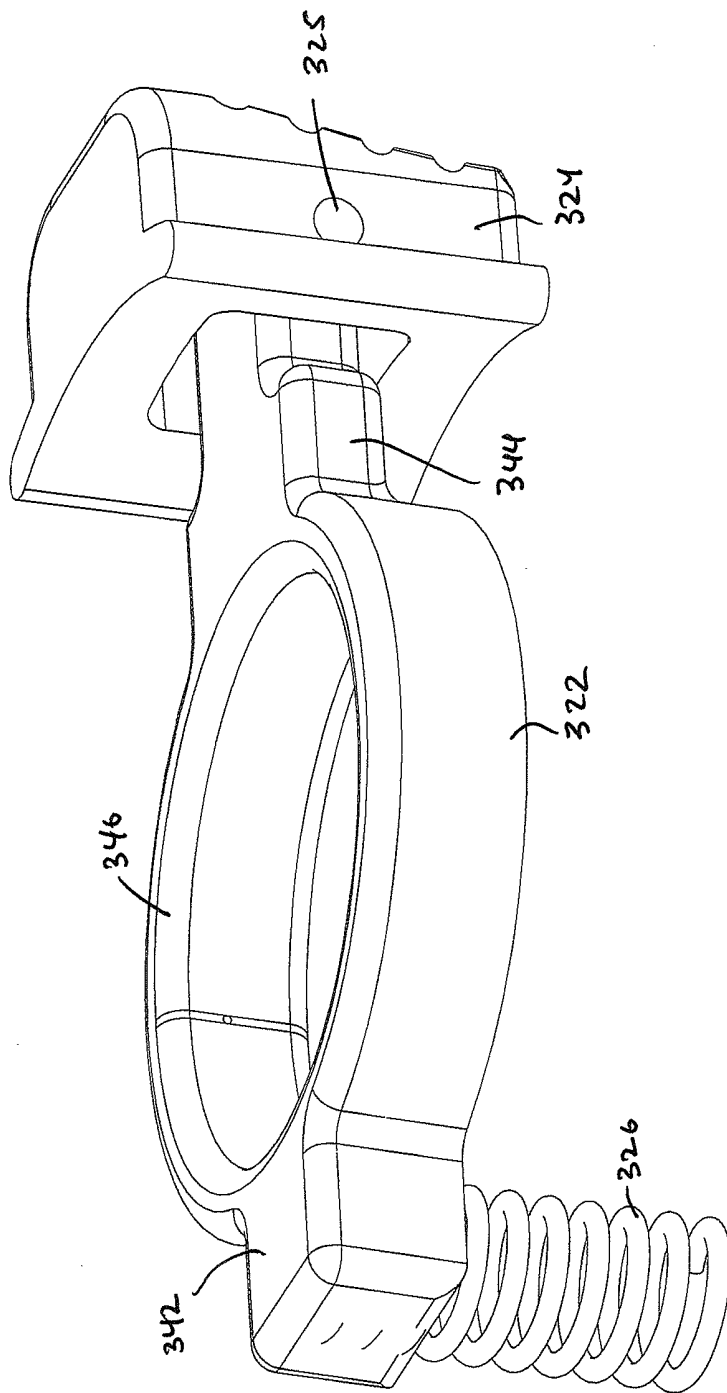

FIG. 4D

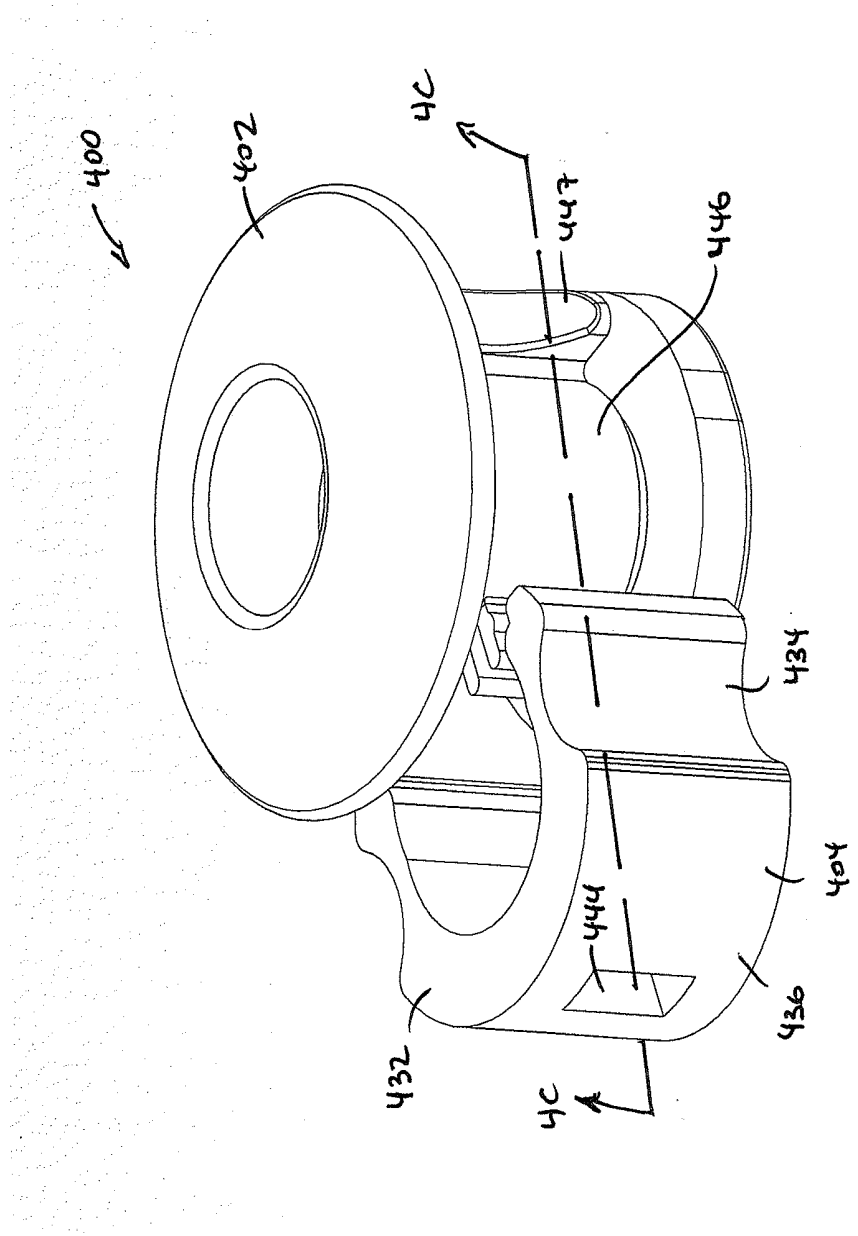

FIG. 5A

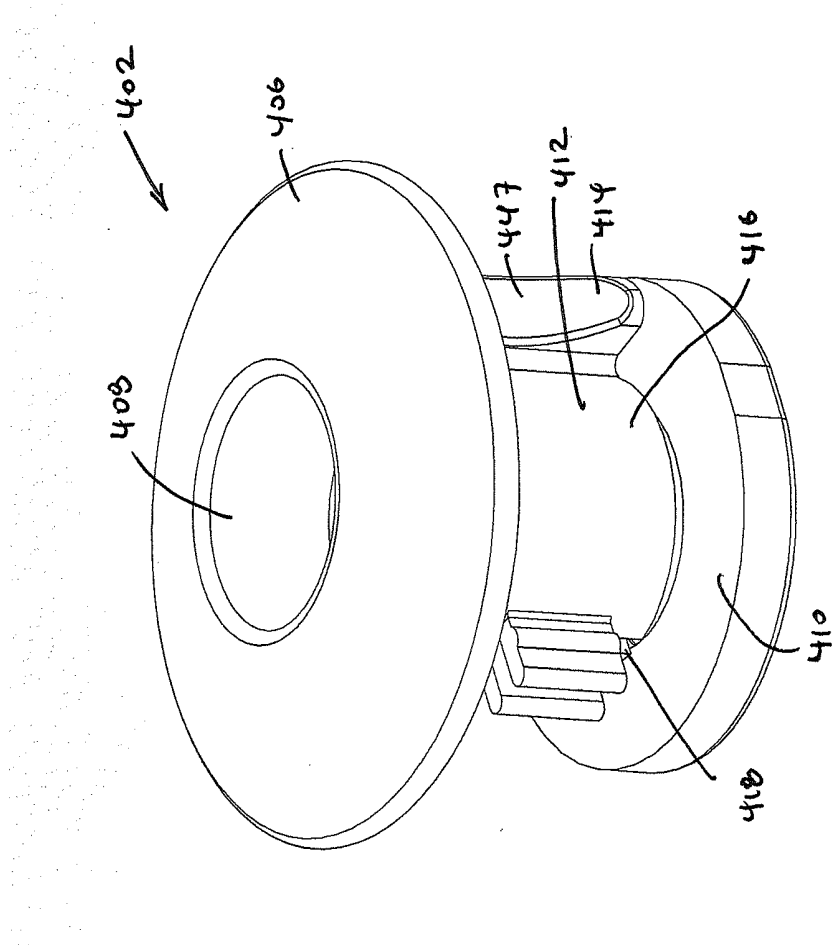

FIG. 5B

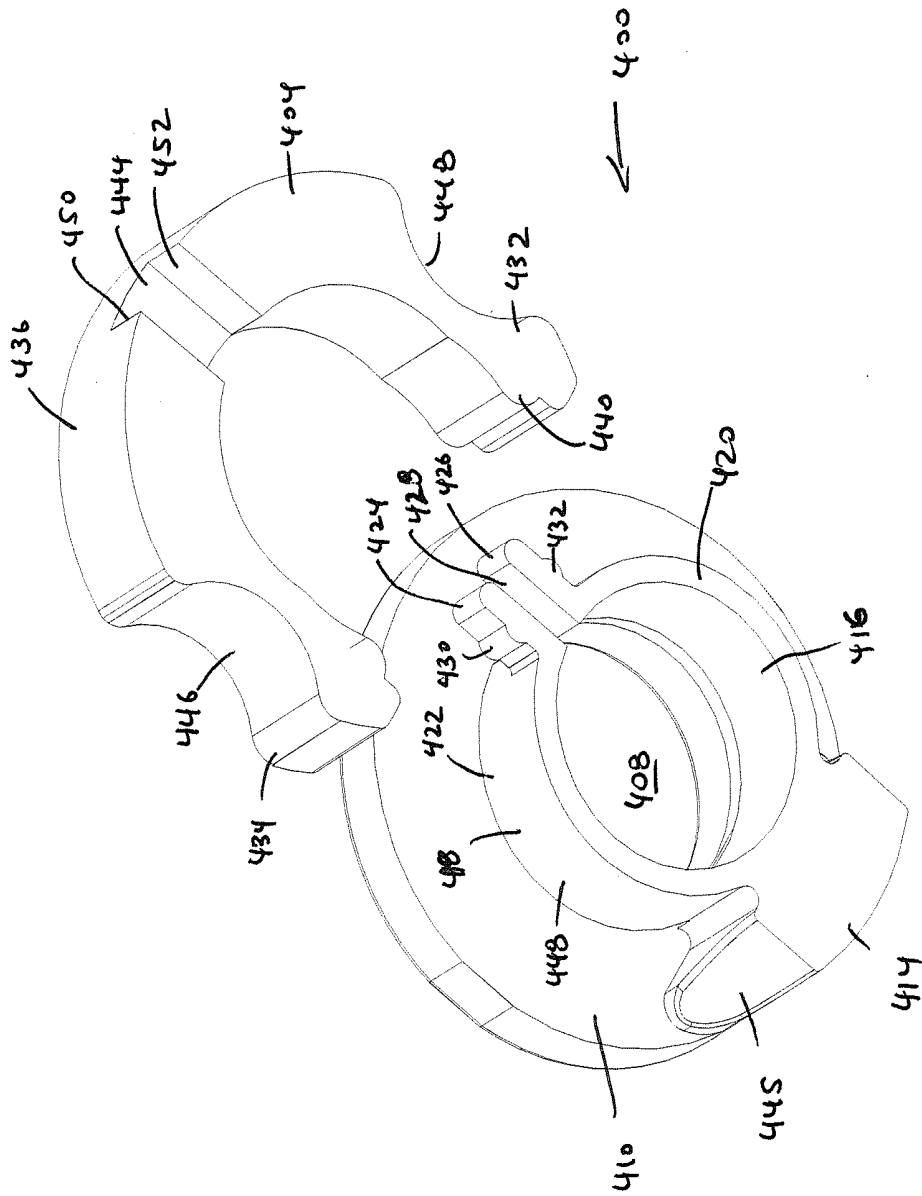

FIG. 5C

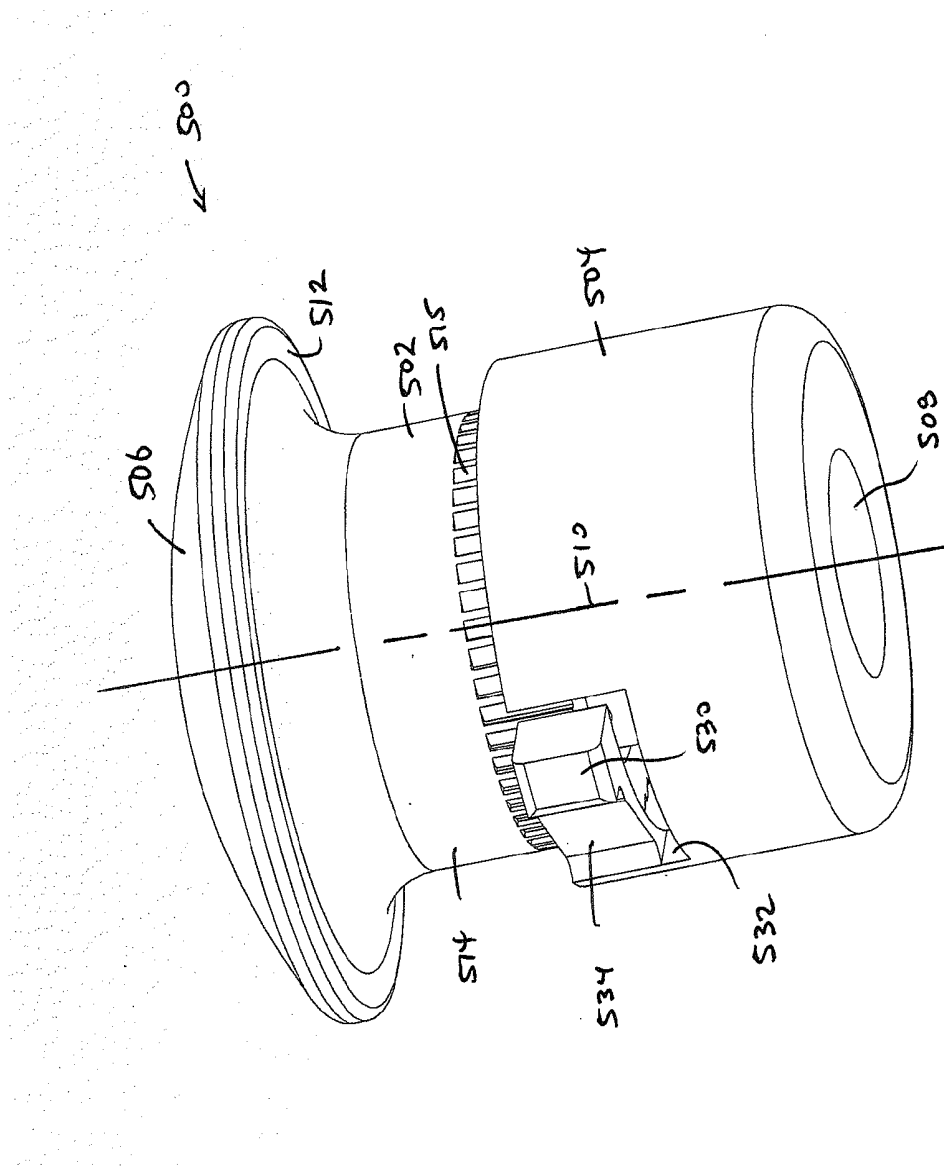

FIG. 6A

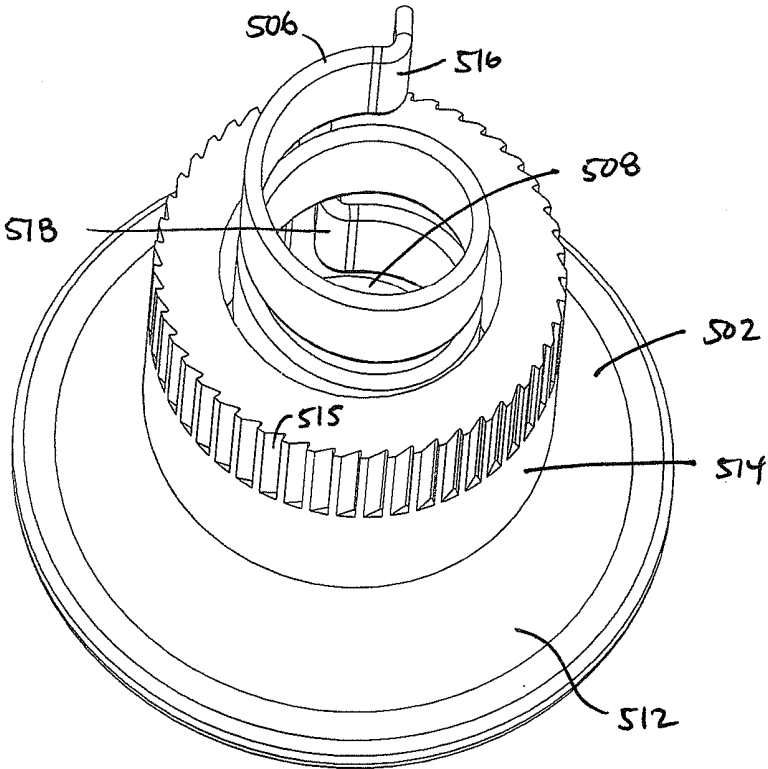

FIG. 6B

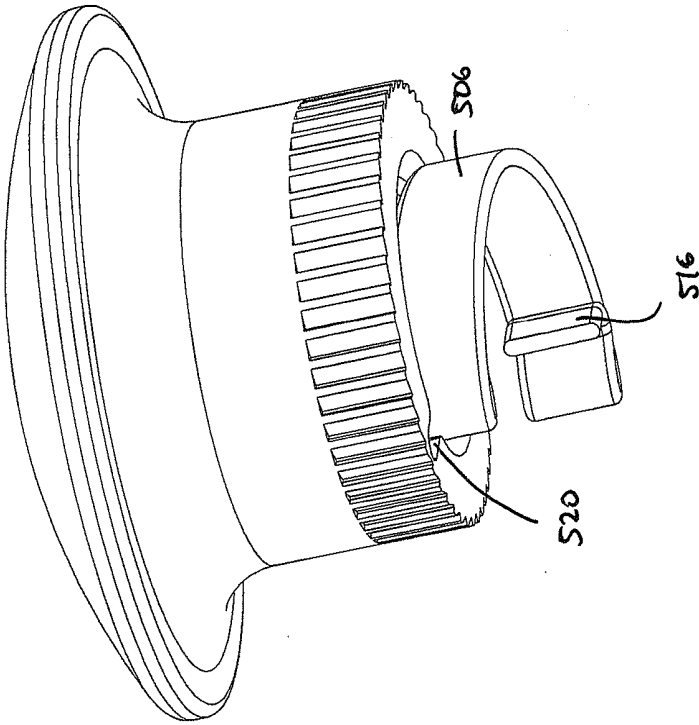

Fig. 6C

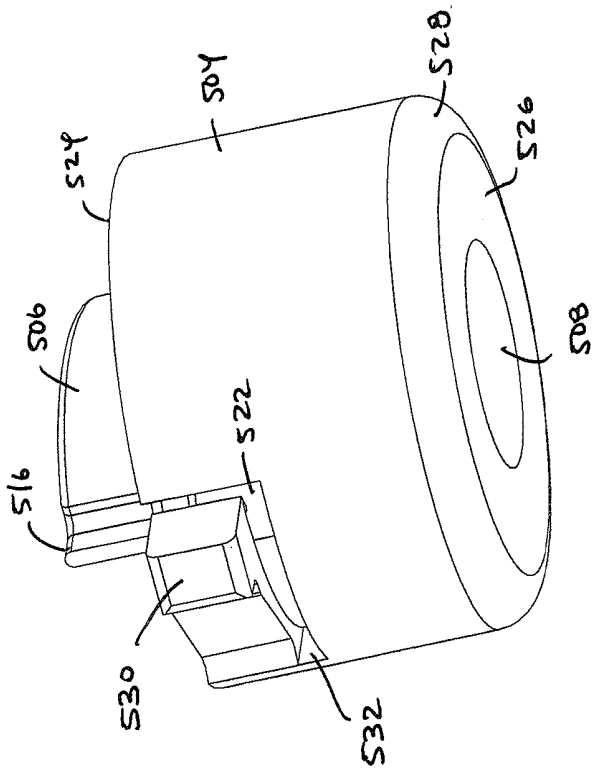

FIG. 6D

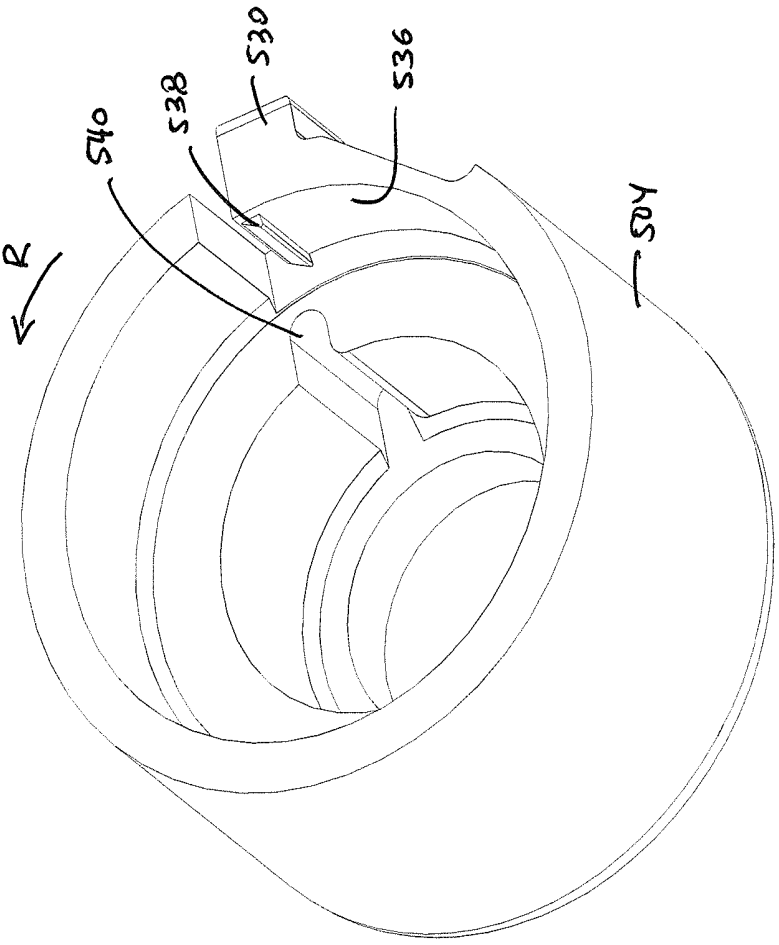

FIG. 6E.

LAPROSCOPIC INSTRUMENT DEPTH STOP

BACKGROUND OF THE INVENTION

[0001] The present invention relates to laparoscopic instrument depth stops, particularly morcellator depth stops.

[0002] Morcellating devices are conventionally utilized for removing tissue from patients during a laparoscopic procedure. Examples of such tissue may be uterine fibroids or even an entire uterus. In some instances, it is desirable to limit the depth of penetration of the morcellating device beneath the skin of a patient to prevent insertion of the morcellating portion of the device beyond the compromised tissue and into healthy tissue below.

[0003] One known method of limiting the depth of penetration is to provide a sliding collar that may be slid up and down the shaft of a morcellating device and locked into place with a locking set screw. Another method includes spacers placed in series on the shaft of the morcellating device. In these devices, the sliding collar or spacers abuts the exterior skin of a patient and serve to restrict the depth in which the shaft may penetrate the body.

BRIEF SUMMARY OF THE INVENTION

[0004] Although well received, these methods have proven to be insufficient for the delicate equipment and in the modern operating arena. In the sliding collar example, the locking screw has proven to be difficult to secure with a gloved hand. Moreover, torquing of the screw creates a point load that can easily damage the morcellator shaft. In the stacked spacer example, depth adjustability is naturally limited by the number and dimensions of the spacers available. It is therefore very difficult to provide a stop at precisely the necessary depth for a particular patient.

[0005] The present invention provides for laparoscopic depth stops that are attachable to a laparoscopic instrument shaft, such as a morcellator shaft, where the depth stops can be adjusted and securely positioned on the shaft to enable infinitely variable positioning with heretofore unknown ease of use. The laparoscopic depth stops described herein also provide the capability of being secured to the morcellator without damaging the morcellator shaft. Principally, the shaft is protected from damage because the forces acted upon it by the inventive devices are non-point load forces, and instead act along a curve, spiral curve, or area.

[0006] In accordance with one embodiment of the invention, there is provided a depth stop for a laparoscopic instrument having a shaft, where the depth stop comprises a first component having a first annular space adapted to allow the shaft to be fitted therethrough, and a second component adapted to be connected to the first component, the second component having a second annular space adapted to allow the shaft to be fitted therethrough. The first annular space and the second annular space form a combined annular space having a first cross sectional area. When the first component is moved relative to the second component the combined annular space reduces to a second cross sectional area less than the first cross sectional area to impart a force on the shaft, the force capable of arresting relative movement of the depth stop along the shaft.

[0007] The movement may be by rotation.

[0008] The reduction in combined annular space may be created by eccentric alignment of the first annular space and second annular space relative to each other. If so provided, the

first component may comprise a handle with a cylindrical portion extending therefrom, the cylindrical portion having an exterior recess. The second component may include a cylindrical well adapted to accept the cylindrical portion of the first component, the cylindrical well having an interior extension adapted to fit within the recess when the first component and the second component are connected.

[0009] The reduction in annular space may be created by tapering of the first annular space. If so provided, the first component may comprise a tapered section and the second component may comprise a collet that conforms to the geometry of the tapered section. The first component and the second component may be threaded together with threads, whereby rotation of the first component and second component relative to each other moves the collet with respect to the tapered section.

[0010] The reduction in annular space may be created by rotation of a stop lever about a point outside the cross sectional area of the shaft. The depth stop may further comprise a spring, the spring imparting a force on the stop lever. The stop lever includes a cylindrical section between a first tab and second tab.

[0011] The second component may be a helical coil. The first component may further comprise a series of recesses, the depth stop further comprising a third component, the third component including a ramp adapted to ratchet with the series of recesses. The depth stop may further comprise a release button adapted to release the ramp from the series of recesses.

[0012] In accordance with a further embodiment, there is provided a depth stop for a laparoscopic instrument having a shaft, where the depth stop comprises a first component having a first annular space with a first cross sectional area adapted to allow the shaft to be fitted therethrough, and a second component adapted to be fitted over portions of the first component to reduce the first annular space to a second cross sectional area less than the first cross sectional area.

[0013] The second component may be fitted over the first component by moving the second component a direction perpendicular to the longitudinal axis of the shaft.

[0014] The second component may be a clip having first and second legs connected by a connector member.

[0015] In accordance with a further embodiment of the invention, there is provided a depth stop for a laparoscopic instrument having a shaft, where the depth stop comprises a first component having a first annular space adapted to allow the shaft to be fitted therethrough. The first annular space has a reducible diameter and an interference surface against which the shaft may be fitted. Upon reduction of the reducible diameter, the interference surface frictionally engages the shaft to arrest relative movement of the depth stop along the shaft.

[0016] The frictional engagement may be along a curve. The curve may be a spiral curve.

[0017] The frictional engagement may form an area.

BRIEF DESCRIPTION OF THE DRAWINGS

[0018] The subject matter regarded as the invention is particularly pointed out and distinctly claimed in the concluding portion of the specification. The invention, however, both as to organization and method of operation, together with features, objects, and advantages thereof, will be or become apparent to one with skill in the art upon reference to the following detailed description when read with the accompanying drawings. It is intended that any additional organiza-

tions, methods of operation, features, objects or advantages ascertained by one skilled in the art be included within this description, be within the scope of the present invention, and be protected by the accompanying claims.

[0019] With respect to the drawings,

[0020] FIG. 1A depicts a conventional depth stop in use on a surgical morcellating device;

[0021] FIG. 1B depicts an alternate embodiment of a conventional depth stop;

[0022] FIG. 2A depicts a perspective view of a depth stop in accordance with a first embodiment of the present invention;

[0023] FIG. 2B depicts a second perspective view of the depth stop of FIG. 2A;

[0024] FIG. 2C depicts a bottom view of the male component forming a portion of the depth stop of FIG. 2A;

[0025] FIG. 2D depicts a top view of the female component forming a portion of the depth stop of FIG. 2A;

[0026] FIG. 2E depicts a perspective view of the male component of FIG. 2C;

[0027] FIG. 2F depicts a perspective view of the female component of FIG. 2D;

[0028] FIG. 3A depicts a depth stop in accordance with a second embodiment of the present invention;

[0029] FIG. 3B depicts a perspective view of the outer component of the depth stop of FIG. 3A;

[0030] FIG. 3C depicts a perspective view of the inner component of the depth stop of FIG. 3A;

[0031] FIG. 4A depicts a perspective view of a depth stop in accordance with a third embodiment of the present invention;

[0032] FIG. 4B depicts a perspective view of a first section of the depth stop of FIG. 4A;

[0033] FIG. 4C depicts a perspective view of the second section of the depth stop of FIG. 4A;

[0034] FIG. 4D depicts a perspective view of select components of the second section of the depth stop of FIG. 4A;

[0035] FIG. 5A depicts a perspective view of a depth stop in accordance with a fourth embodiment of the present invention;

[0036] FIG. 5B depicts a perspective view of the base component of the depth stop of FIG. 5A;

[0037] FIG. 5C depicts a cross sectional view of the depth stop of FIG. 5A;

[0038] FIG. 6A depicts a perspective view of a depth stop in accordance with a fifth embodiment of the present invention;

[0039] FIG. 6B depicts a perspective view of the inner portion and helical gripper of the depth stop of FIG. 6A;

[0040] FIG. 6C depicts a second perspective view of the inner portion and helical gripper of the depth stop of FIG. 6A;

[0041] FIG. 6D depicts a perspective view of the outer portion and helical gripper of the depth stop of FIG. 6A; and

[0042] FIG. 6E depicts a perspective view of the outer portion of the depth stop of FIG. 6A.

DETAILED DESCRIPTION

[0043] In the following are described the preferred embodiments of the laparoscopic instrument depth stop of the present invention. In describing the embodiments illustrated in the drawings, specific terminology will be used for the sake of clarity. However, the invention is not intended to be limited to the specific terms so selected, and it is to be understood that each specific term includes all technical equivalents that operate in a similar manner to accomplish a similar purpose. Where like elements have been depicted in multiple embodi-

ments, identical reference numerals have been used in the multiple embodiments for ease of understanding.

[0044] As discussed above, the invention features laparoscopic depth stops that are attachable to laparoscopic devices. For ease of discussion, a morcellator will be used as a representative device. However, other laparoscopic devices are to be considered within the context of this disclosure.

[0045] The present disclosure therefore provides for depth stops for a morcellator having a shaft, where the depth stops can be adjusted with infinitely variable positioning and then secured to the shaft. The laparoscopic depth stops described herein also provide the capability of being secured to the morcellator without damaging its shaft by applying force to the shaft in a form other than a point load. For example, the forces applied may be along a curve, spiral, or within an area.

[0046] As discussed above, conventional depth stops are known. FIG. 1A discloses one such conventional depth stop 600A generally comprising a sliding collar 602 that may slide along the shaft 604 of a morcellator 606, or other laparoscopic device. The sliding collar 602 includes a locking screw 608 that may be tightened to lock the sliding collar against the shaft 604. Thus, when the shaft 604 of the morcellator 606 is inserted through the skin S of a patient, its end 610 may be prevented from extending beyond compromised tissue CT to be removed and into healthy tissue HT.

[0047] In so locking the device of FIG. 1A, it will be appreciated that the forces acting on the shaft 604 by virtue of the locking screw 608 are point forces. No matter how much care is taken by the surgeon in securing the sliding collar 602, these point forces may damage the delicate shaft 604 of the surgical tool.

[0048] FIG. 1B depicts an alternative conventional system. Here, the depth stop 100B generally comprises a series of spacers 612, 614, 616 that may be stacked to limit the excursion of the shaft 604 into the skin S. The number of spacers and the size of the spacers may be varied as required. Nevertheless, there are only a reasonable number of different size spacers to choose from, and the depth stop is therefore not infinitely variable.

[0049] Generally speaking, the depth stops of the present invention provide for curve, spiral, or area contact between portions of the depth stop and the morcellator shaft rather than point contact. These configurations help to equalize or counteract forces acting on the morcellator shaft while also minimizing the impact of such forces resulting in both improved functionality and reduced risk of damaging the morcellator shaft. Additionally, the depth stops of the present invention provide infinitely variable depth control by being adjustable in an infinite number of positions.

[0050] In accordance with one embodiment, presented initially in a first perspective view in FIG. 2A, a depth stop 100 comprises a male component 102 and a female component 104. As will be discussed, the male component 102 and female component 104 engage each other and may be turned relative to each other to offset eccentric lumens that engage the shaft of a morcellator to lock the depth stop 100 in place.

[0051] The male component 102 comprises a handle 106 which in the embodiment shown is generally formed in the shape of a mushroom. Other configurations that easily fit within the grasp of a gloved surgeon are also contemplated. Moreover, the handle may be knurled or may include depressions 108, as shown, to aid in tactile feel and grip.

[0052] Extending from a central location of the bottom portion 110 of the handle 106 is a male connector 112. The

male connector **112** is configured as an open cylindrical structure with an annular wall **114** forming an annular space **115**. Formed in the generally smooth outer portions **116** of the annular wall **114** are a pair of recesses **118**, **120**. As best shown in FIG. 2A with respect to recess **118**, the recesses **118**, **120** each include a first portion **122** extending through the annular wall **114** to the termination **124** thereof. In turn, the first portion **122** extends in the opposite direction into a second portion **126** generally configured transverse to the first portion and extending partially around the central axis **128** of the male component **102** and particularly the male connector **112**.

[0053] FIG. 2B depicts the depth stop **100** in a second perspective view highlighting the female component **104**. As shown, the female component **104** is generally configured as a circular component forming an annular ring **130**. The annular ring **130** forms a well, is generally smooth on its interior portion **132**, and may be knurled or otherwise shaped on its outer portion **134** to facilitate handling by a gloved surgeon. As shown in FIG. 2B, the outer portion **134** is preferably scalloped. Extending from the interior portion **132** into the annular space **136** provided by the annular ring **130** are a pair of extensions **138**, **140**. The extensions **138**, **140** may be formed as part of the female component **104** or may be formed as separate pins that are fitted in apertures of the female component and affixed therein.

[0054] In the embodiment shown, the extensions **138**, **140** are tubular but it will be appreciated that the extensions may be configured as other shapes and configurations provided that such shapes or configurations are adapted to fit within the recess **118** of the male connector **112**. It will also be appreciated that the male component **102** and female component **104** may be fitted together by positioning the extensions **138**, **140** first into the first portions **122** (and the other corresponding first portion) of the recesses **118**, **120** and then into the second portions **126** (and the other corresponding second portion). Upon rotation of the male component **102** relative to the female component, the extensions **138**, **140** will travel through the second portions **126** (and the other corresponding second portion) to lock the two components together.

[0055] FIG. 2C depicts a bottom view of the male component **102**. Highlighted for reference are the bottom portion **110** of the handle **106** and male connector **112**. From this view, it will be appreciated that the geometric centerline **142** of the annular wall is offset from the geometric centerline **144** of the outer portion **116** of the male connector **112** by a distance "d." Distance "d" is preferably 0.20" and the exact tolerance would depend on the materials used and the tolerance range of the instrument. This offset creates a first eccentricity.

[0056] A second eccentricity is shown in FIG. 2D, a top view of the female component **104**. The eccentricity can be seen by examination of the apertures formed by the top portion **146** of the annular ring **120**, which is also shown in FIG. 2B, versus the bottom wall **148** within the annular space **136**. Here, the geometric centerline **150** of the top portion **146** (and the outer portion **134**) is offset a distance "d2" from the geometric centerline **152** of the bottom wall **148**. Notably, the female component **104** includes a notch **154** on its outer wall aligning with the smaller annular diameter of the female component while the male component also includes a similar notch **156** (FIG. 2C) aligning with the smaller annular diameter thereof. When the two notches **154**, **156** are aligned, so too are the extensions **138**, **140** and the recesses **118**, **120**.

[0057] A morcellator shaft may be positioned through the annular space **115** of the male component and the annular space **136** of the female component **104** with the two components connected and the notches **154**, **156** aligned. The depth stop **100** may then be moved up or down the morcellator shaft to a desired position, whereby the surgeon may rotate one or both of the male component **102** and female component **104** to provide for a shift in the two annular spaces **115**, **136**. This shift reduces the overall cross sectional area of the combined annular space. It will be appreciated that the annular spaces **115**, **136** are sized such that this shift and reduction in size locks the depth stop **100** against the morcellator shaft by virtue of friction alone. To unsecure the depth stop **100**, the surgeon merely has to rotate the two components in the opposite direction. If it is desired to take the two components apart, the surgeon rotates in the opposite direction the full excursion permitted and pulls the components apart as the extensions **138**, **140** are removed from the recesses **118**, **120**.

[0058] For clarity, FIGS. 2E and 2F are also provided, with FIG. 2E being a further perspective view of the male component **102** and FIG. 2F being a further perspective view of the female component **104**.

[0059] A second embodiment of the invention is provided in FIG. 3A in the form of depth stop **200**. Depth stop **200** comprises two major components, an outer component **202** and an inner component **204**. As shown in FIG. 3A, the inner component and outer component may be fitted together.

[0060] A perspective view of the outer component **102** is shown in FIG. 3B. As shown, the outer component comprises a gripping portion **206** and a base portion **208**. The base portion **208** is generally round while the gripping portion **206** extends outwardly therefrom with a series of fins **210**. The fins **210** are separated by scalloped sections **212** to enable the gloved hand of a surgeon to interact with the outer component **202**. Of course, other configurations are possible.

[0061] Extending through a central portion of the outer component **202** is a lumen **214** having an inner wall **216**. The inner wall **216** of the lumen includes threads **218**. It will be appreciated that the inner wall **216** of the lumen **214** tapers from a first diameter near the base **208** to a smaller second diameter near the upper extent of the fins **210**.

[0062] FIG. 3C depicts a perspective view of the inner component **204** of the depth stop **200**. The inner component **204** comprises a handle section **220** and a collet section **222**. The handle section **220** is configured with arrayed fins **224** separated by scalloped sections **226** to aid with a surgeon's grasping of the depth stop **202**.

[0063] The collet section **222** extends outwardly from the base **226** of the handle section **220** toward a collet section terminus **228**. It will be appreciated that the collet section **222** is sized and configured to fit within the lumen **214** of the outer component **202** and includes threads **230** for mating with the threads **218** of the outer section. When so engaged, the outer component **202** and inner component **204** may be rotated relative to each other to advance the inner component, and specifically the collet section **222**, further into the lumen **214** of the outer component.

[0064] The collet section is tubular and includes a lumen **229** therethrough. At the terminus **228** of the collet section **222** are collets **232a**, **232b**, **232c**, **232d**. Although four such collets are shown, there may be as few as one or more than four. As the collet section **222** is advanced through the lumen **214** of the outer component **202**, the collets **232a**, **232b**, **232c**,

232d are squeezed together into the spaces 234a, 234b, 234c, 234d there between by virtue of the tapered inner wall 216

[0065] It will be appreciated that when the lumen 214 of the outer component 202 and the lumen 229 of the collet section 222 of the inner component 204 are threaded through the shaft of a morcellator, the components are free to slide up and down thereon. The inner and outer components 202, 204 are sized and configured such that when the inner component is threaded into the outer component, and the two components are rotated relative to each other, the collets 232a, 232b, 232c, 232d will squeeze together by virtue of the tapered inner wall 216 of the lumen 214 to squeeze the morcellator shaft and affix the depth stop 200 thereon. Relative rotation in the opposite direction serves to unfix the two depth stop 200 from the shaft by releasing the collets 232a, 232b, 232c, 232d.

[0066] It will be appreciated that the depth stop 200 may be sized and configured such that the collets 232a, 232b, 232c, 232d provide effective force on the morcellator shaft without damaging the shaft. Also, the thread pitch may be engineered to limit the rotation necessary to achieve such effective force, or may be engineered to permit finer control by requiring a greater degree of rotation to achieve the effective force.

[0067] A third embodiment of the invention is first depicted in FIG. 4A as depth stop 300. Depth stop 300 comprises a first section 302 and a second section 304. The first section 302 is generally mushroom-shaped and includes a mushroom cap 306 and base section 308. The second section 304 is generally cylindrical and connects with the base section 308 of the first section 302.

[0068] The first section 302 is shown in greater detail in FIG. 4B. Here, it can be seen that the base section 308 comprises a plurality of separate sections, including an open cylindrical section 310. The open cylindrical section 310 includes a partial cylinder section 312 with an open section 314. Opposite the open section 314 is a plug 316 extending from the exterior wall 318 of the open cylindrical section 310. Lastly, the open cylindrical section also includes a plurality of apertures 320.

[0069] FIG. 4C depicts a top perspective view of the second section 304. The second section 304 comprises several components, including a stop lever 322, actuator slide 324, spring 326, and a cylindrical body 328. The cylindrical body 328 generally comprises a base 330 and a cylindrical upstanding wall 332 extending therefrom. The cylindrical upstanding wall 332 includes an annular space 334 within its confines. It will also be appreciated that the base 330 includes an aperture 336.

[0070] The upstanding wall 332 includes an open section 338 adjacent to which is the actuator slide 324. The actuator slide 324 includes an opening 340 facing inward relative to the second section 304 and ribs 342 facing outward. The ribs 342 facilitate tactile feel of a gloved surgeon.

[0071] The stop lever 322 extends across the upstanding wall 332 from a portion opposite the open section 338, where it connects to spring 326, to the open section 338. In turn, the spring 326 connects between the stop lever 322 and the base 330 of the cylindrical body 328.

[0072] The configuration of the stop lever 322, spring 326, and slide 324 are shown in FIG. 4D. In FIG. 4D, it is shown that the stop lever 322 includes a spring tab 342 on a first side for connecting to the spring 326 and a slide tab 344 on a second side for connecting to the slide 324. Between the spring tab 342 and the slide tab 344 is a cylindrical section 346. In the standard configuration, it will be appreciated that

the stop lever 322 is parallel to the base 330 of the cylindrical body 328 such that the lumen 348 of the cylindrical section 346 presents its greatest cross sectional area to a morcellator shaft extending through the cylindrical body. The connection between the spring tab 342 and spring 326 may be a pressure fit within an aperture (not shown) of the 342, or other means. The connection between the slide tab 344 and slide 324 is preferably by way of a pin 325.

[0073] It is also noted that the cylindrical body 332 includes a plurality of apertures 350, generally corresponding to the size and configuration of the apertures 320 of the first section 302. Thus, when the first section 302 and second section 304 of the depth stop 300 are brought together, pins (not shown) may be driven through the aligned apertures 320, 350 to connect the two members. So connected, it will be appreciated that a shaft of a morcellator may be threaded through the aperture of the first member (not shown, but configured at the upper extremity of the mushroom head 306), the stop lever 322, and the aperture 336 of the base 330. In the standard configuration, the depth stop 300 is free to slide up and down the morcellator shaft. However, upon positioning in a location where it is desired that the depth stop 300 be secured, the surgeon merely shifts the slide 324 from a first position, upward within the open section 338 toward the plug 316 which fits within the open section. This action tends to rotate the stop lever 322 about its intersection with the spring 326, outside the cross sectional area of the shaft, and effectively reduces the cross sectional area presented to the shaft by the cylindrical section 346 of the stop lever 322. As such, it will be appreciated that a line force is imposed around a portion of the circumference of the shaft by the stop lever 322, effectively securing the depth stop 300.

[0074] A fourth embodiment of the invention is provided starting with FIG. 5A, which depicts depth stop 400. Depth stop 400 comprises two components, a base 402 and clamp 404.

[0075] As shown in FIG. 5B, the base 402 comprises a domed upper portion 406 with a lumen 408 extending through its central portion. Opposite of the domed upper portion 406 is a circular foot 410. Connecting the domed upper portion 406 and the foot 410 is a split strap 412. It will be appreciated that the lumen 408 extends through the split strap 412 and the foot 410.

[0076] The split strap 412 comprises an anchor 414 which provides the actual connection between the domed upper portion 406 and the foot 410. Extending from the anchor 414 are two arms 416, 418 (418 is most clearly shown in FIG. 5C).

[0077] FIG. 5C is a cross sectional view of the depth stop 400. As shown in FIG. 5C, the arms 416, 418 are created as opposing arches 420, 422 forming a portion of the lumen 408. The arches 420, 422 begin at the anchor 414 and terminate with tabs 424, 426 which are spaced apart to leave a gap 428. As will be discussed later, the arches 420, 422 may flex at the anchor to open or close the gap 428. Approximately midway along their respective lengths, the tabs 424, 426 include bulges 430, 432.

[0078] Also shown in FIG. 5C is the clamp 404. Clamp 404 is generally shaped as a horse shoe with a pair of open arms 432, 434 and a connector 436. The open arms 432, 434 and connector 436 form an inner surface 438 with cams 440, 442 at its end opposite the connector 436. At the connector 436, the clamp 404 also comprises an aperture 444.

[0079] It will be appreciated that in operation, the clamp 404 may be grasped by a gloved surgeon at recesses 446, 448

located approximately centrally on its arms 432, 434. The open end (at the arms 432, 434, opposite the connector 436) of the clamp 404 may then be slid against the outer walls 446, 448 of the arches 420, 422 of the split strap 412, simultaneously spreading the arms 432, 434 of the clamp and squeezing the gap 428 of the split strap. To aid in holding the base 402, the anchor includes grasping regions 445, 447. Continuing pressure on the recesses 446, 448 further cams open the clamp 404 by action of the cams 440, 442 against the outer walls 446, 448 of the arches 420, 422. Upon sufficient excursion of the clamp 404 around the split strap 412, when the cams 440, 442 reach the decreasing radius of the split strap 412, the clamp will “pop” into place forcing the tabs 424, 426 to enter the aperture 444 at the connector 436. The inner walls of the recess 450, 452 cooperate with the bulges 430, 432 to effectively close the gap 428, or at least reduce its size. This decreases the diameter of the lumen 408 in the area of the split strap 412.

[0080] In this regard, the base 402 of the depth stop 400 may be placed on the shaft of a surgical instrument, such as a morcellator, by threading the shaft through the lumen 408. The base 402 may then be moved up or down the shaft to a desired stop location. At that location, a surgeon may connect the clamp 404 to the base 402 as discussed above to reduce the diameter of the lumen 408 at the split strap 412 and effectively lock the split strap against the shaft. When it is desired to move the depth stop 400, the surgeon simply removes the clamp 400 by pulling back on the recesses 446, 448 in a manner opposite to assembly while supporting the base at the grasping regions 445, 447.

[0081] The fifth embodiment of the present invention is shown initially in FIG. 6A, a perspective view of the depth stop 500. Depth stop 500 comprises three components, an inner portion 502, outer portion 504, and helical gripper 506 (best shown in FIG. 6B).

[0082] The inner portion 502 begins, opposite its connection with the outer portion 504, with a mushroom head 506. Although shown in FIG. 6A only at its exit at the outer portion 504, the mushroom head 506 includes a lumen 508 through its central axis 510. The lumen is sized and configured to accept a shaft of a surgical instrument, such as a morcellator. Tapering down from the base 512 of the mushroom head 506 is a cylindrical portion 514. As shown in FIG. 6B, a perspective view of the underside of the inner portion 502, the cylindrical portion 514 ends with a series of sloped recesses 515 around its perimeter. It will be appreciated that these sloped recesses 515 form a portion of a ratchet, as will be discussed.

[0083] Also shown in FIG. 6B is the lumen 508 of the inner portion 502. Within the lumen 508 is the helical gripper 506, which includes at one end a first bent tab 516 and at its second end a second bent tab 518. The second bent tab 518 is fitted within a recess 520, best shown in FIG. 6C, of the lumen 508 of the inner portion 502.

[0084] FIG. 6D depicts a perspective view of the outer portion 504 with helical gripper 506 protruding therefrom. The outer portion 504 is generally cylindrical with a cutout 522 near its upper end 524. At the lower end 526 of the outer portion 504, there is a chamfered edge 528. The lumen 508 passes through the cylindrical outer portion 204 from the lower end 526 to the upper end 524.

[0085] Within the cutout 522 is a cantilevered release button 530. As suggested, the release button 530 is cantilevered from an inner wall 532 of the cutout 522 by a pliable arm 534.

[0086] FIG. 6E depicts a top perspective view of the outer portion 504. Here, the release button 530 can be seen from its rear 536. On the rear section 536 is mounted a ramp 538. It will be appreciated that when assembled with the inner portion 502, this ramp 538 fits within the one of the series of recesses 515. By virtue of the ramped shape of the ramp 538, and the slope of the recesses 515, the outer portion 504 may rotate relative to the inner portion 502 in the direction of arrow R while the cantilevered release button 530 ratchets from one recess 515 to the next.

[0087] Also shown is slot 540. Upon assembly of the depth stop 500, the first bent tab 516 is fitted within the slot 540. Recall that the second bent tab 518 is fitted within recess 520 of the inner portion 502. As the outer portion 504 is rotated relative to the inner portion 502 in the direction of arrow R, the helical gripper 506 is tightened such that its relative cross sectional area is reduced. In the meantime, the outer portion 504 is prevented from rotating in the direction opposite of arrow R by virtue of the ratcheting of the release button 530, and specifically action of the ramp 538 fitting within the one of the series of recesses 515. When it is desired to permit rotation of outer portion 504 in the direction opposite of arrow R, the release button 530 may be lifted to pull the ramp 538 away from, and out of interaction with, the recesses 515. This serves to increase the relative diameter of the helical gripper 506.

[0088] It will therefore be appreciated that in use, the depth stop 500 may be fitted on a shaft of a surgical instrument, such as a morcellator. When the depth stop 500 is in a position where it is desired to be affixed, a surgeon may rotate the outer component 504 relative to the inner component 502 in the direction of arrow R to tighten the helical gripper 506 around the shaft. Ratchet action of the ramp 538 and recesses 515 will prevent loosening until such time that the release button 530 is lifted.

[0089] Each of the components described in the various embodiments may be configured from a variety of materials. Preferably, such materials are suitable for the surgical arena and have engineering properties suitable for their use. For example, the materials should be capable of repeated use and heat sterilization. Such materials include various metals, polymers, and the like. Items such as spring 326 are preferably metal. Other components, such as the helical gripper 506, may be configured from silicone.

[0090] Although the invention herein has been described with reference to particular embodiments, it is to be understood that these embodiments are merely illustrative of the principles and applications of the present invention. It is therefore to be understood that numerous modifications may be made to the illustrative embodiments and that other arrangements may be devised without departing from the spirit and scope of the present invention as defined by the appended claims.

I claim:

1. A depth stop for a laparoscopic instrument having a shaft, where the depth stop comprises:
 - a first component having a first annular space adapted to allow the shaft to be fitted therethrough;
 - a second component adapted to be connected to the first component, the second component having a second annular space adapted to allow the shaft to be fitted therethrough;

the first annular space and the second annular space forming a combined annular space having a first cross sectional area;

wherein when the first component is moved relative to the second component the combined annular space reduces to a second cross sectional area less than the first cross sectional area to impart a force on the shaft, the force capable of arresting relative movement of the depth stop along the shaft.

2. The depth stop of claim 1, wherein said movement is rotation.

3. The depth stop of claim 1, wherein the reduction in combined annular space is created by eccentric alignment of the first annular space and second annular space relative to each other.

4. The depth stop of claim 3, wherein:

the first component comprises a handle with a cylindrical portion extending therefrom, the cylindrical portion having an exterior recess; and

the second component includes a cylindrical well adapted to accept the cylindrical portion of the first component, the cylindrical well having an interior extension adapted to fit within said recess when said first component and said second component are connected.

5. The depth stop of claim 1, wherein the reduction in annular space is created by tapering of the first annular space.

6. The depth stop of claim 5, wherein the first component comprises a tapered section and the second component comprises a collet that conforms to the geometry of the tapered section.

7. The depth stop of claim 6, wherein the first component and the second component are threaded together with threads, whereby rotation of the first component and second component relative to each other moves the collet with respect to the tapered section.

8. The depth stop of claim 1, wherein the reduction in annular space is created by rotation of a stop lever about a point outside the cross sectional area of the shaft.

9. The depth stop of claim 8, further comprising a spring, said spring imparting a force on said stop lever.

10. The depth stop of claim 9, wherein said stop lever includes a cylindrical section between a first tab and second tab.

11. The depth stop of claim 1, wherein said second component is a helical coil.

12. The depth stop of claim 11, wherein said first component further comprises a series of recesses; said depth stop further comprising a third component, said third component including a ramp adapted to ratchet with said series of recesses.

13. The depth stop of claim 12, further comprising a release button adapted to release said ramp from said series of recesses.

14. A depth stop for a laparoscopic instrument having a shaft, where the depth stop comprises:

a first component having a first annular space with a first cross sectional area adapted to allow the shaft to be fitted therethrough;

a second component adapted to be fitted over portions of the first component to reduce the first annular space to a second cross sectional area less than the first cross sectional area.

15. The depth stop of claim 14, wherein the second component is fitted over the first component by moving the second component a direction perpendicular to the longitudinal axis of the shaft.

16. The depth stop of claim 14, wherein the second component is a clip having first and second legs connected by a connector member.

17. A depth stop for a laparoscopic instrument having a shaft, where the depth stop comprises:

a first component having a first annular space adapted to allow the shaft to be fitted therethrough;

the first annular space having a reducible diameter and an interference surface against which the shaft may be fitted;

wherein, upon reduction of the reducible diameter, the interference surface frictionally engages the shaft to arrest relative movement of the depth stop along the shaft.

18. The depth stop of claim 17, wherein the frictional engagement is along a curve.

19. The depth stop of claim 18, wherein the curve is a spiral curve.

20. The depth stop of claim 17, wherein the frictional engagement forms an area.

* * * * *

专利名称(译)	Laprosopic仪器深度停止		
公开(公告)号	US20140276907A1	公开(公告)日	2014-09-18
申请号	US13/798664	申请日	2013-03-13
[标]申请(专利权)人(译)	NERING ROBERT Shalhoub埃利亚斯N		
申请(专利权)人(译)	NERING , ROBERT SHALHOUB , ELIAS N.		
当前申请(专利权)人(译)	ETHICON INC.		
[标]发明人	NERING ROBERT SHALHOUB ELIAS N		
发明人	NERING, ROBERT SHALHOUB, ELIAS N.		
IPC分类号	A61B17/32		
CPC分类号	A61B17/320016		
外部链接	Espacenet USPTO		

摘要(译)

公开了一种用于具有轴的腹腔镜器械的无限可调深度限位器，该深度限位器包括第一部件，该第一部件具有适于允许轴穿过其中的第一环形空间。第一环形空间具有可减小的直径和干涉表面，轴可以安装在干涉表面上。在减小可减小直径时，干涉表面与轴摩擦接合以阻止深度限位器沿轴的相对运动。摩擦接合可以沿曲线，螺旋曲线或区域。还提供了用于重新打开可缩小直径以释放深度限位器的装置。

