



(19) **United States**

(12) **Patent Application Publication**  
**Albrecht et al.**

(10) **Pub. No.: US 2012/0123202 A1**  
(43) **Pub. Date: May 17, 2012**

(54) **INSUFFLATING OPTICAL SURGICAL INSTRUMENT**

(60) Provisional application No. 60/584,302, filed on Jun. 29, 2004.

(75) Inventors: **Jeremy J. Albrecht**, Rancho Santa Margarita, CA (US); **John R. Brustad**, Rancho Santa Margarita, CA (US); **Scott V. Taylor**, Rancho Santa Margarita, CA (US); **Gary M. Johnson**, Rancho Santa Margarita, CA (US); **Nabil Hilal**, Rancho Santa Margarita, CA (US)

**Publication Classification**

(51) **Int. Cl.**  
*A61B 1/06* (2006.01)  
*A61M 13/00* (2006.01)  
*A61B 1/018* (2006.01)  
(52) **U.S. Cl.** ..... **600/104**; 600/249; 604/26

(73) Assignee: **APPLIED MEDICAL RESOURCES CORPORATION**, Rancho Santa Margarita, CA (US)

(57) **ABSTRACT**

An insufflating surgical instrument adapted for movement across an abdominal wall to insufflate an abdominal region of a patient is disclosed. The instrument comprises a shaft having an insufflation channel extending between a proximal end and a distal end, the insufflation channel being adapted for connection to a source of fluid under pressure at the proximal end. A tip is at the distal end and a vent hole is formed in the tip being in connection with the insufflation channel and adapted to expel fluid under pressure to insufflate the abdominal region. The tip is formed of a transparent material to facilitate visualization of the abdominal wall and region. The shaft includes a lumen extending along the axis between the proximal end and the distal end to enable insertion of a laparoscope. The lumen and insufflation channel may be formed as separate channels or as one shared channel.

(21) Appl. No.: **13/356,260**

(22) Filed: **Jan. 23, 2012**

**Related U.S. Application Data**

(63) Continuation of application No. 12/766,118, filed on Apr. 23, 2010, now Pat. No. 8,128,590, which is a continuation of application No. 11/170,567, filed on Jun. 29, 2005, now Pat. No. 7,708,713, which is a continuation-in-part of application No. 10/956,167, filed on Oct. 1, 2004, now Pat. No. 7,947,058.

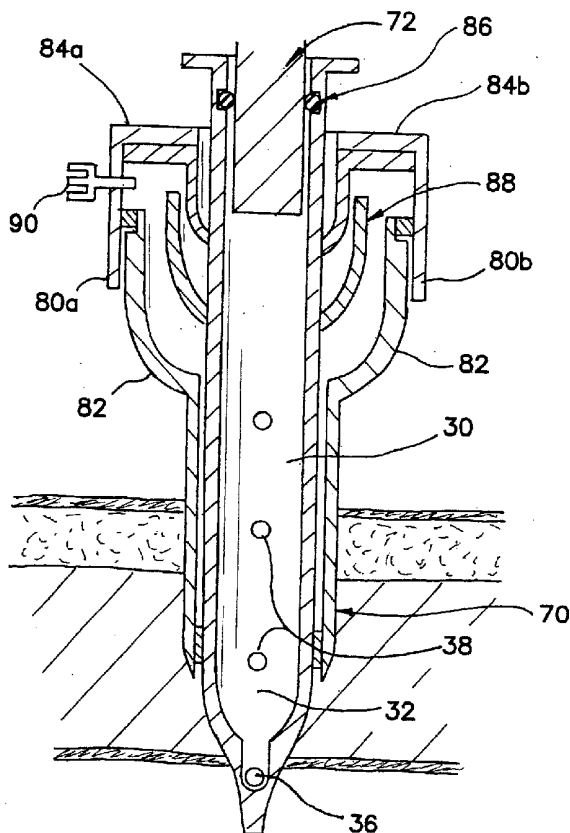

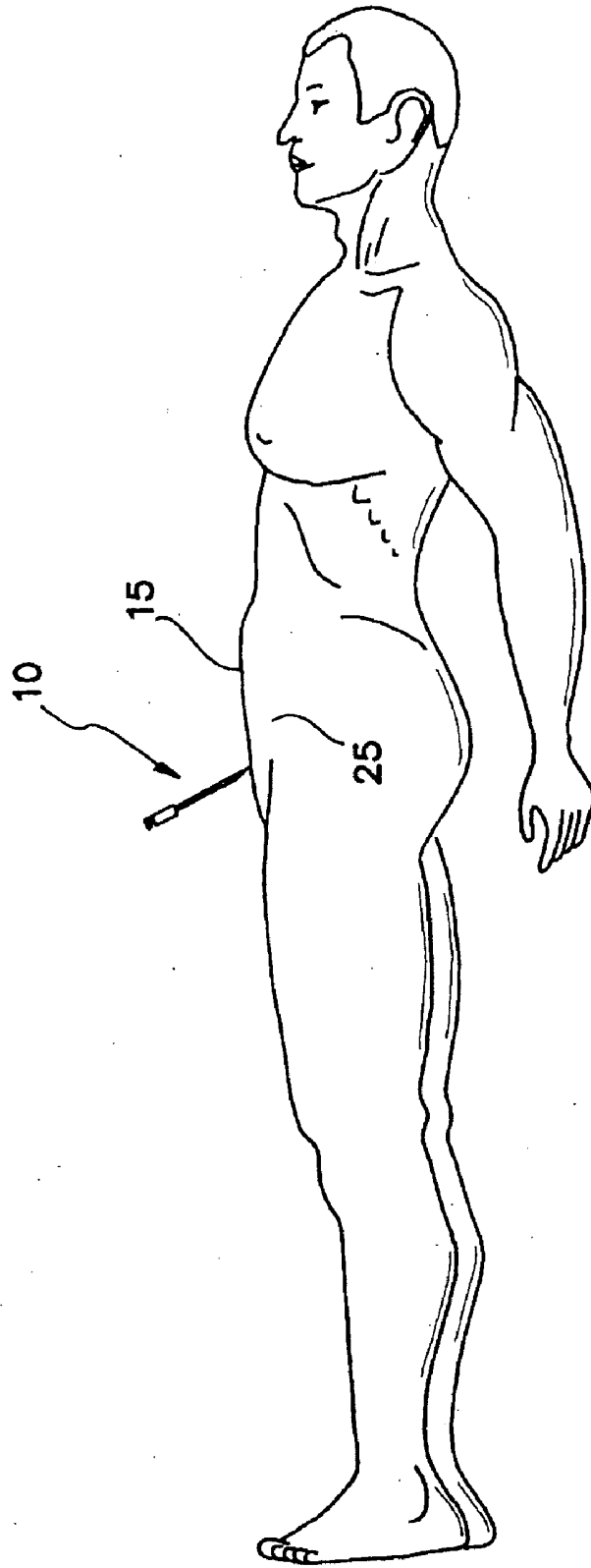

**FIG. 1**  
**PRIOR ART**

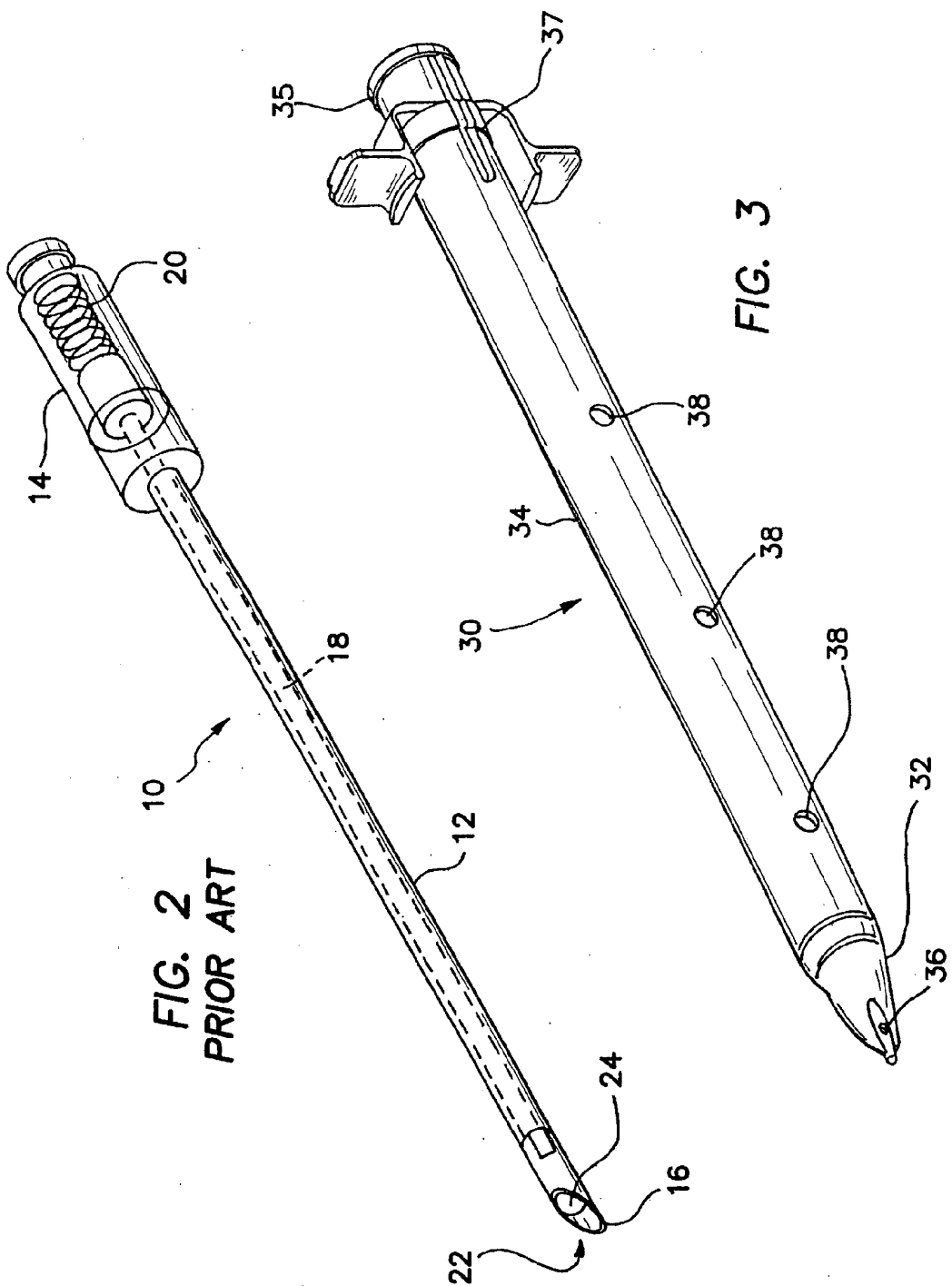

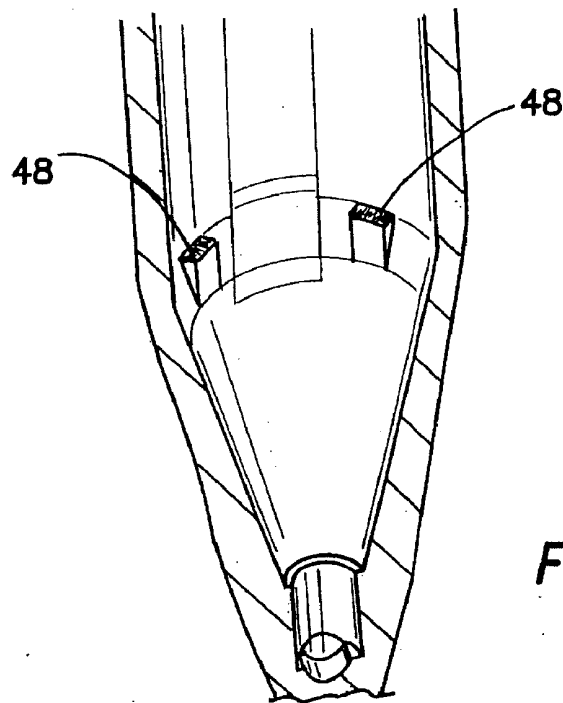
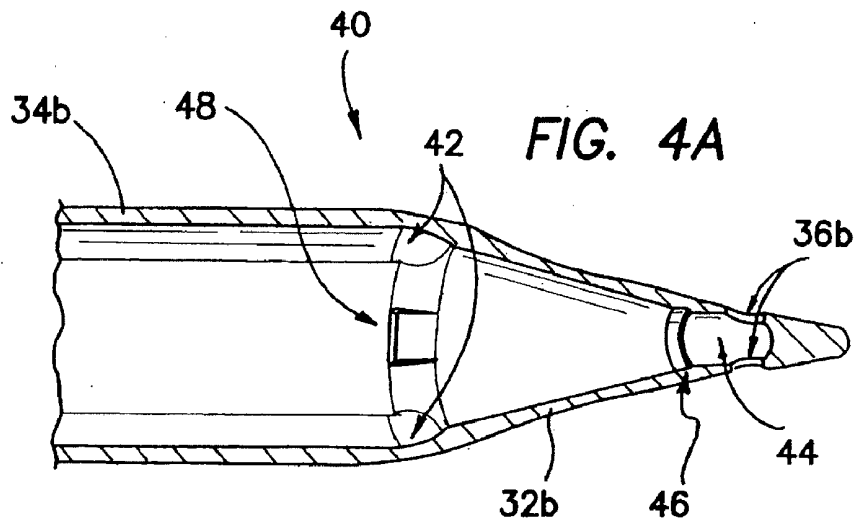

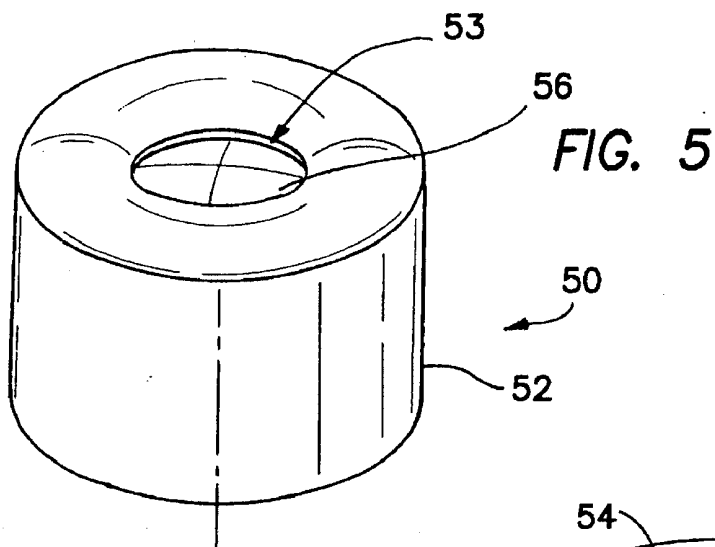
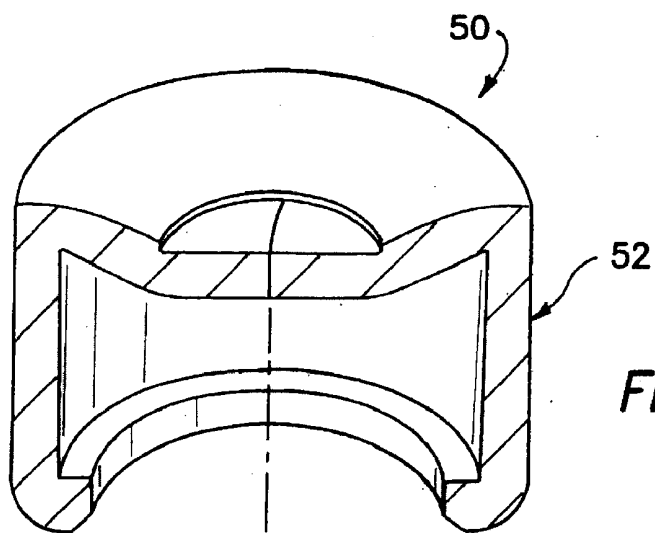
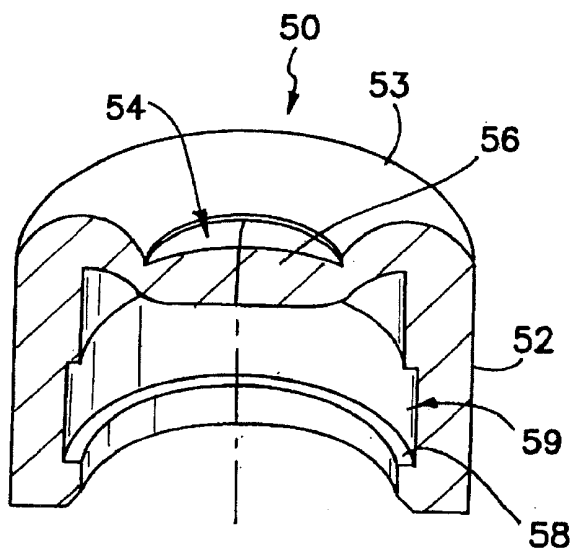

FIG. 6A



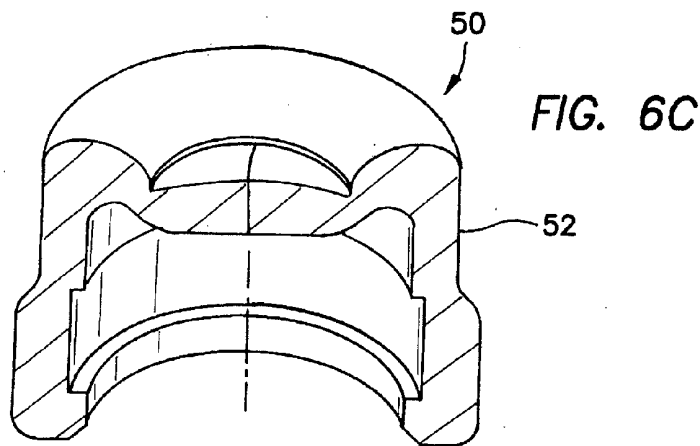

FIG. 6D

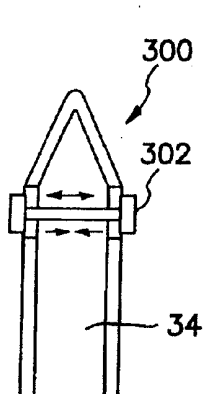
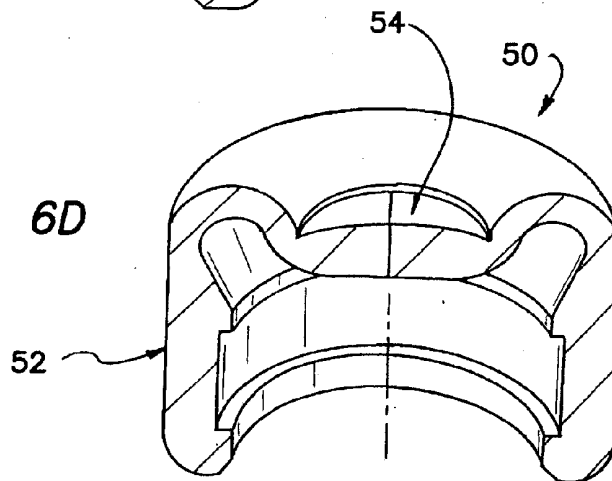

FIG. 15A

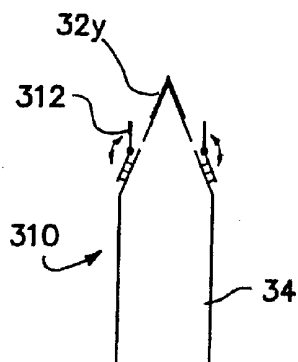

FIG. 15B

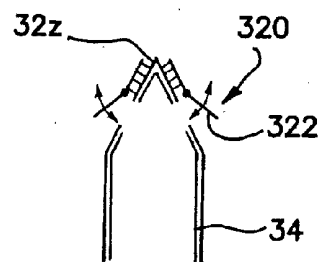
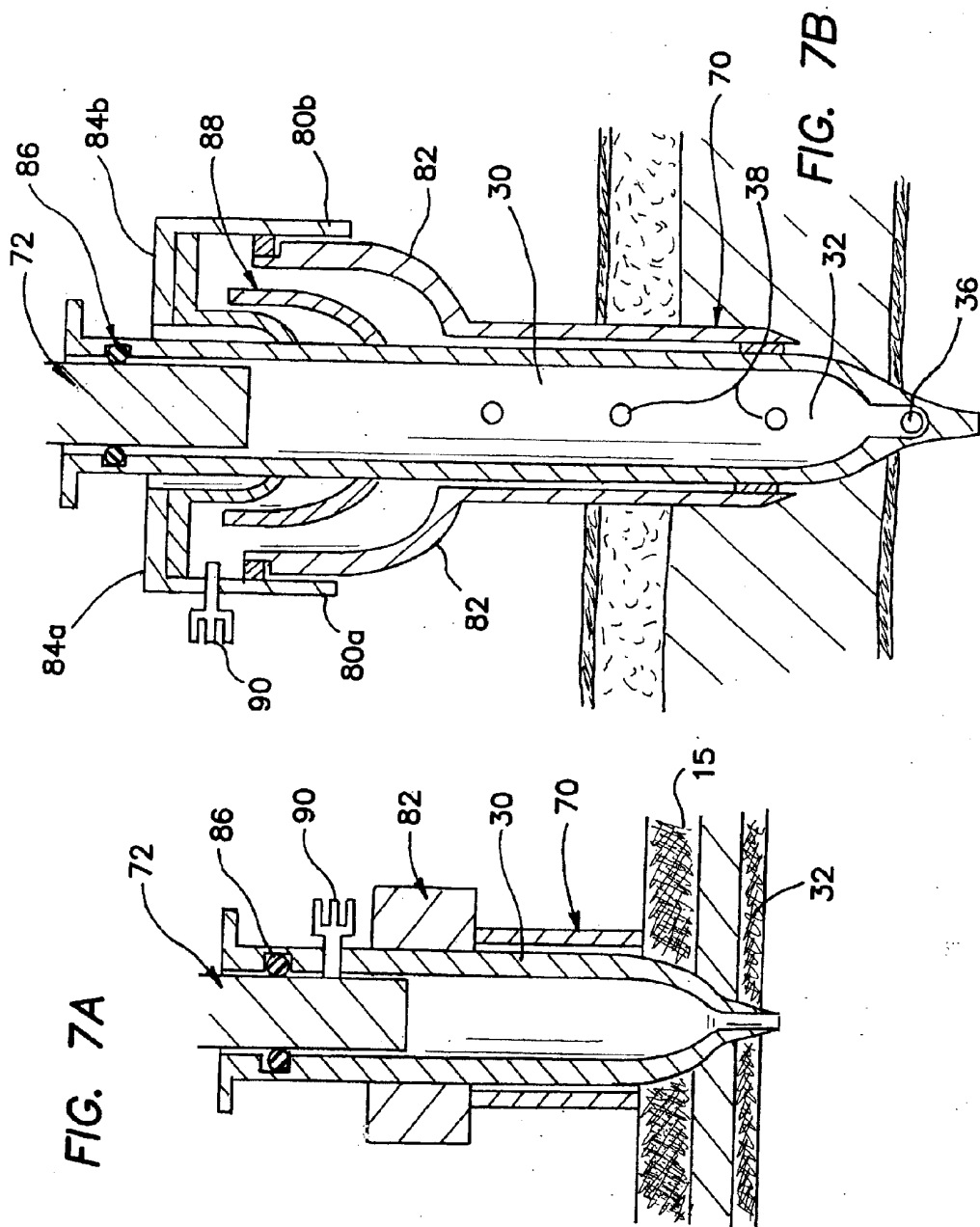

FIG. 15C



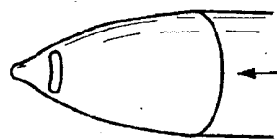

FIG. 8A

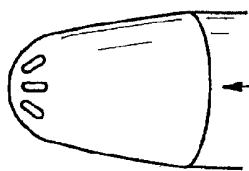

FIG. 8B

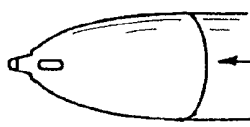

FIG. 8C

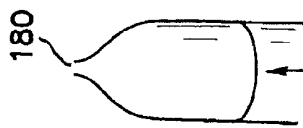

FIG. 8D

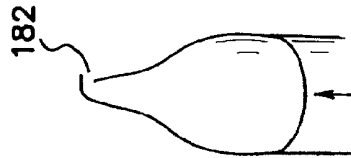

FIG. 8E

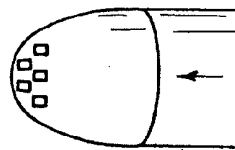

FIG. 8F

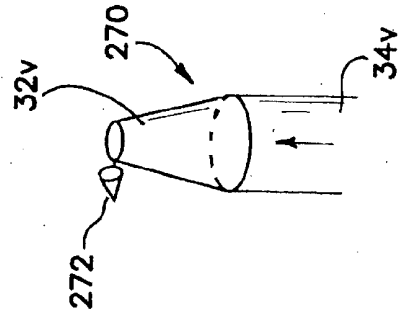

FIG. 14A

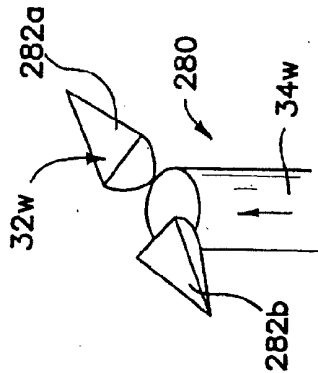

FIG. 14B

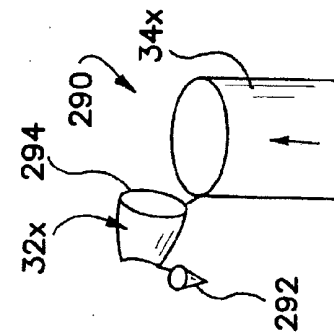

FIG. 14C

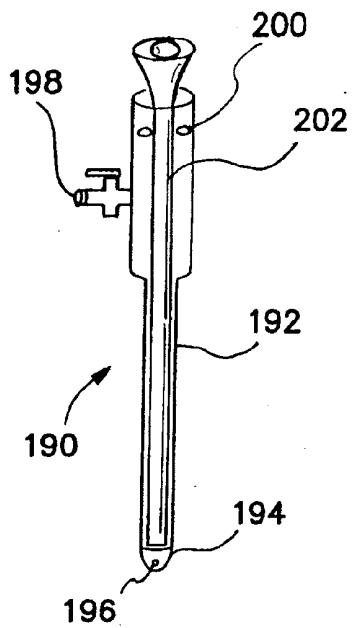

FIG. 9

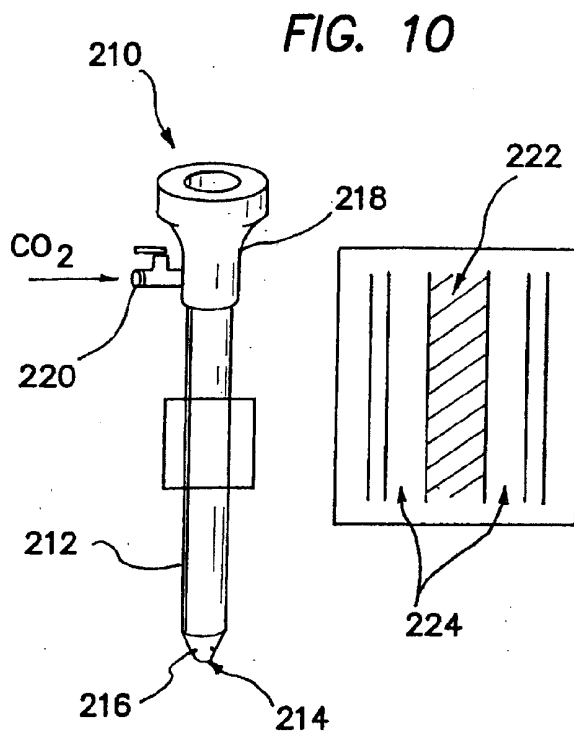
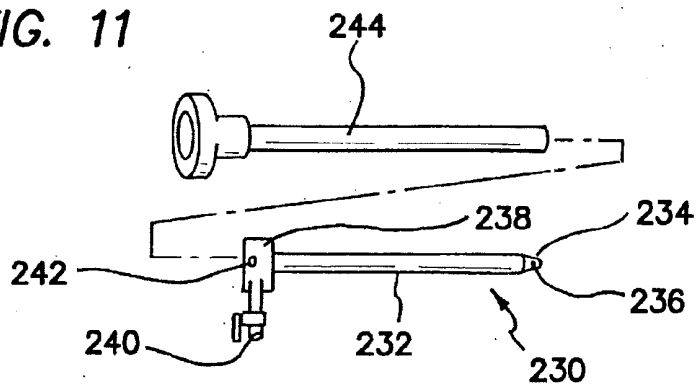

FIG. 10

FIG. 11



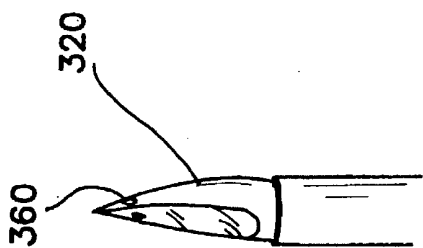

FIG. 12A

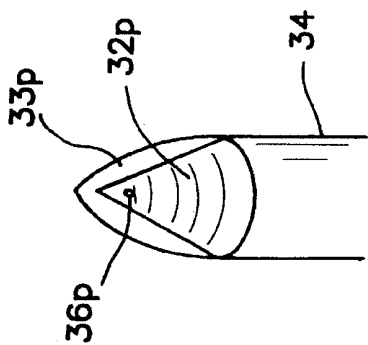

FIG. 12B

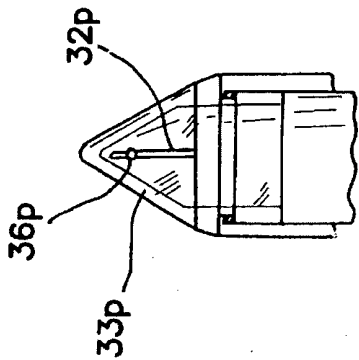

FIG. 12C

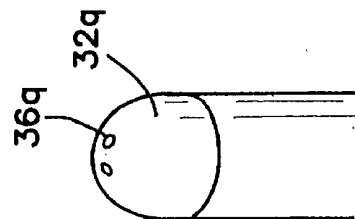

FIG. 12D

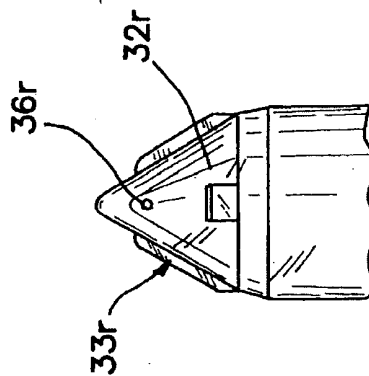

FIG. 12E

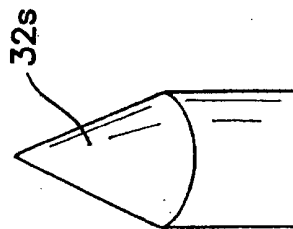
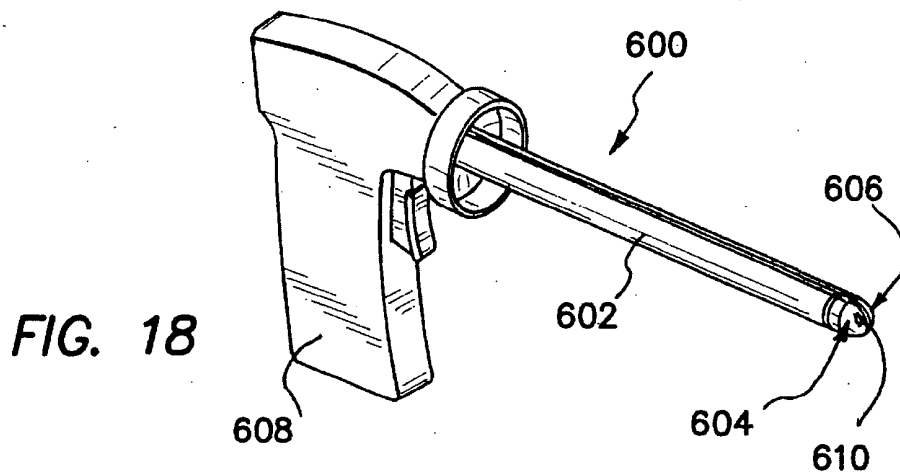
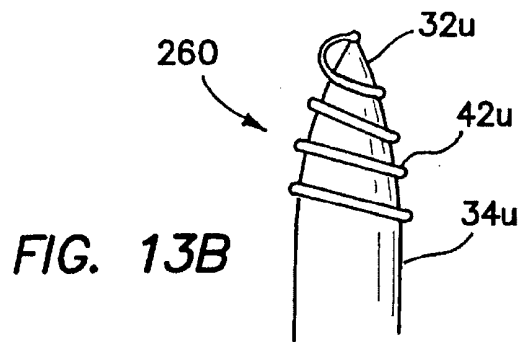
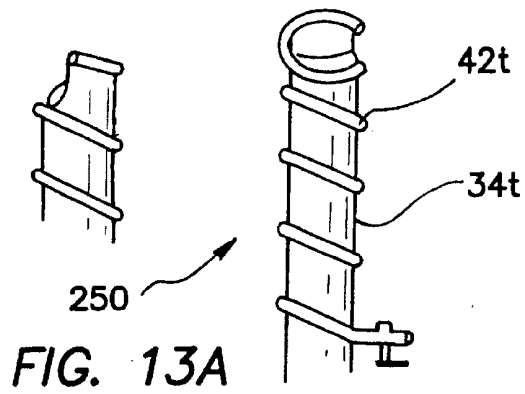

FIG. 12F



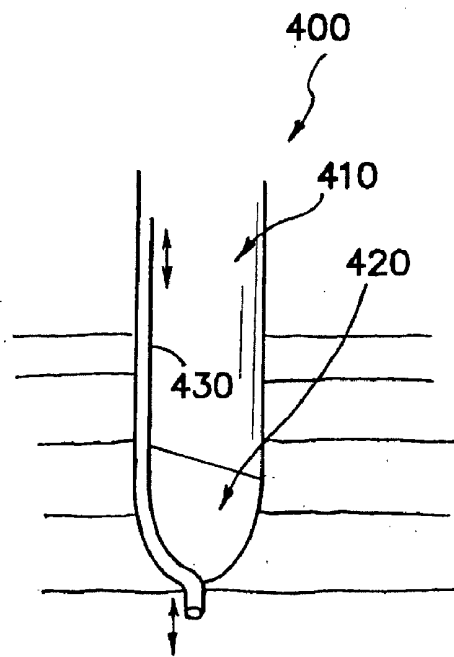

FIG. 16

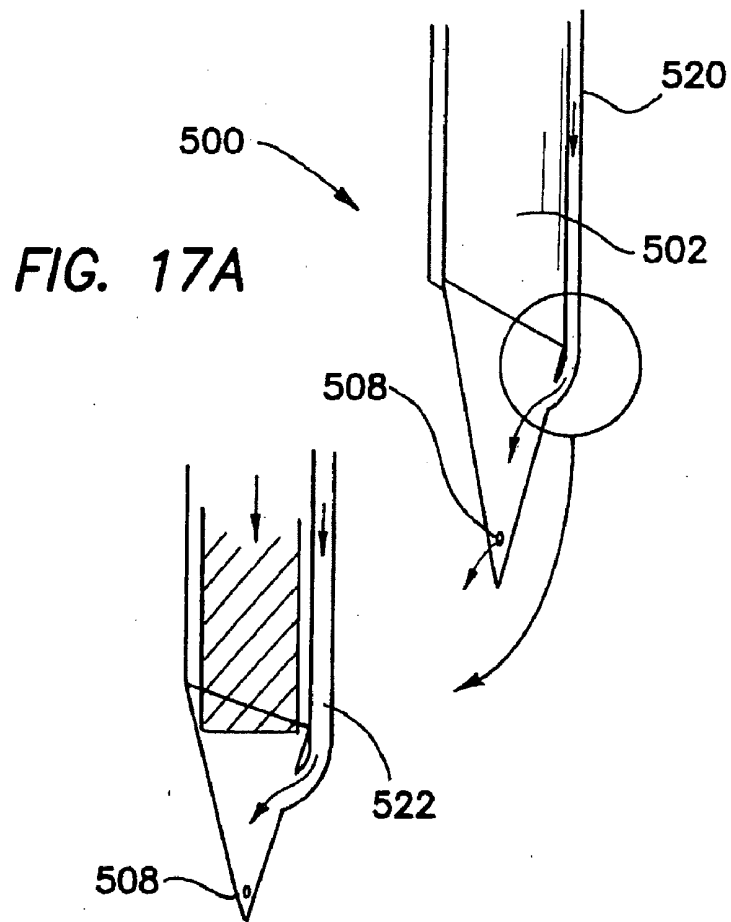
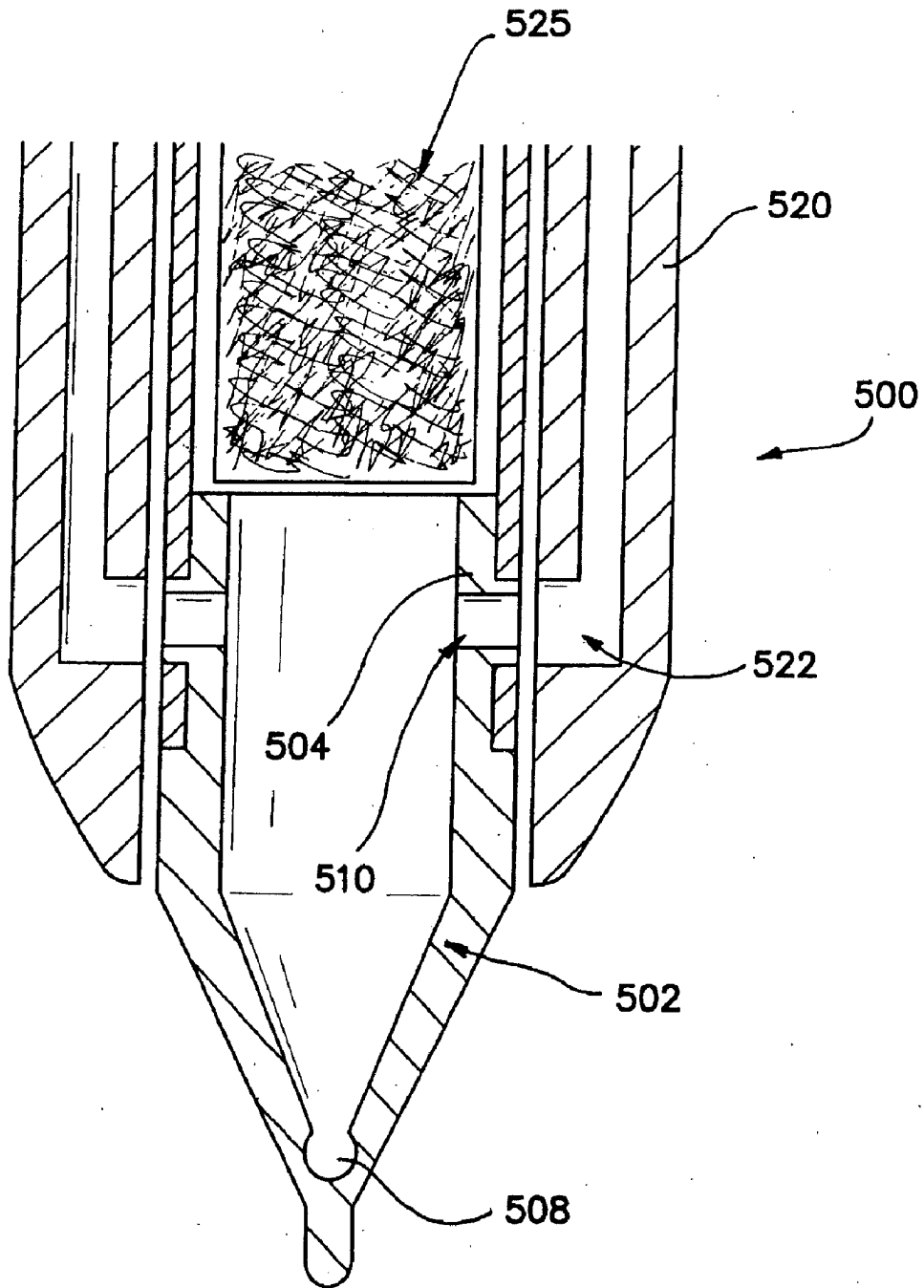

FIG. 17A

**FIG. 17B**



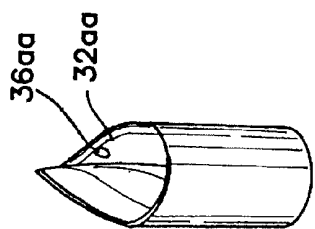

FIG. 19A

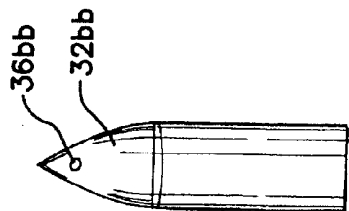

FIG. 19B

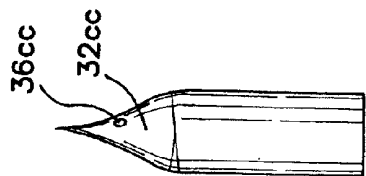

FIG. 19C

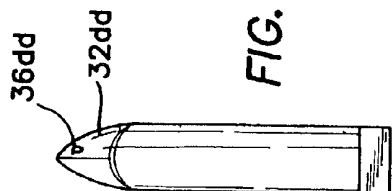

FIG. 19D

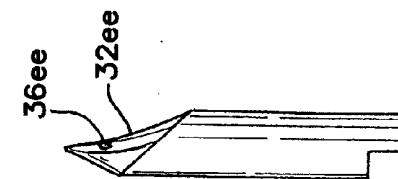

FIG. 19E

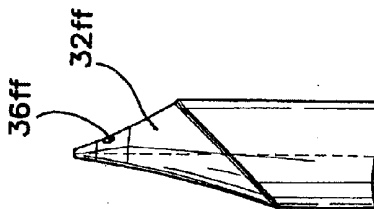

FIG. 19F

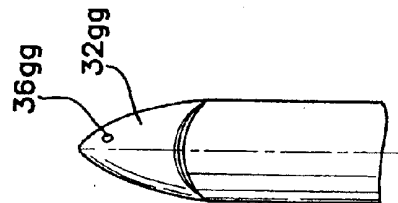

FIG. 19G

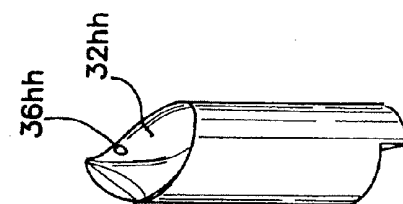

FIG. 19H

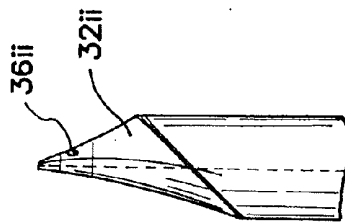

FIG. 19I

## INSUFFLATING OPTICAL SURGICAL INSTRUMENT

### CROSS-REFERENCE TO RELATED APPLICATIONS

**[0001]** This application is a continuation of non-provisional application Ser. No. 12/766,118, filed Apr. 23, 2010, entitled "Insufflating Optical Surgical Instrument", which is a continuation of non-provisional application Ser. No. 11/170,567, filed Jun. 29, 2005, now U.S. Pat. No. 7,708,713, issued May 5, 2010, entitled "Insufflating Optical Surgical Instrument", which is a non-provisional application claiming the priority of provisional application Ser. No. 60/584,302, filed on Jun. 29, 2004, entitled "Insufflating Optical Surgical Instrument," which is fully incorporated herein by reference. This non-provisional application is also filed as a continuation-in-part application claiming the priority of patent application Ser. No. 10/956,167, filed on Oct. 1, 2004, entitled "Bladeless Optical Obturator," which is fully incorporated herein by reference.

### FIELD OF THE INVENTION

**[0002]** This invention generally relates to surgical instruments and, in particular, to surgical instruments providing visual entry and visual insufflation.

### BACKGROUND OF THE INVENTION

**[0003]** Laparoscopic surgery of the abdominal area typically requires the introduction of an insufflation gas into the peritoneal cavity of the patient. The insufflation gas is usually pressurized to about 10 mm Hg above atmospheric pressure. This in turn lifts the abdominal wall away from the organs underlying it. Cannulas having seals are then placed at various locations through the abdominal wall to allow the use of a laparoscope and operating instruments. It is well known that establishing access to a non-inflated peritoneal cavity can be a very dangerous part of any laparoscopic procedure. The most common method to achieve insufflation is to pass a sharp needle through the abdominal wall and into the abdominal region, and then inject a gas through the needle and into the region thereby creating an enlarged or ballooned cavity to accommodate a laparoscopic procedure. Unfortunately, insertion of the needle has been required without any visual aid to facilitate location of the sharp needlepoint. In order to reduce the probability of inadvertent penetration of delicate internal organs in this "blind" procedure, the sharp insufflation needle has been provided with a spring-loaded and retractable safety mechanism.

**[0004]** The safety mechanisms associated with most insufflation needles consist of a blunt or rounded member disposed within the lumen of the needle, and biased by a spring to an extended position beyond the needle tip. This spring must be responsive to the insertion pressure during placement of the needle but must be capable of immediately moving forward when that pressure is relieved. This is a highly mechanical event at best and offers less than optimal arrangement. As pointed out above, a drawback of this procedure is it is performed blindly. A consequence of this blind insertion is the surgeon may inadvertently damage the organs and tissues underlying the abdominal wall such as major blood vessels and the intestinal tract. Once access is gained, it can take several minutes for the gas to insufflate the abdomen and

while this is happening the surgeon may be unaware of any complications caused by the insertion of the needle.

**[0005]** Another commonly used method of gaining initial access to the peritoneal cavity is by using a procedure known as the Hasson technique. This method involves making a mini-laparotomy and using the fingers to bluntly dissect the tissues of the abdominal wall and thereby creating an access similar to an open surgical procedure. This method is generally considered to be safer but not without risks, and results in an access site that is not well suited for the subsequent introduction and use of a laparoscopic cannula. The cannula is typically held in place with an additional device that allows the cannula to be tied down with sutures to prevent it from slipping out of the abdominal wall. This also leaves a large defect and is difficult to perform in large abdominal walls.

**[0006]** Some surgeons have used trocars designed for use with laparoscopes for the initial entry into the peritoneal cavity. These devices allow the placement of a laparoscope through the internal diameter of the trocar and have a trocar tip that is made of clear plastic to allow the surgeon to visualize the passage of the tip through the abdominal wall. However, in order to allow the subsequent introduction of insufflation gas through the cannula, the trocar and cannula must be inserted all the way through the wall of the abdomen and this in turn can be potentially dangerous as the tip of the trocar may have to advance as much as one inch beyond the distal surface of the abdominal wall and into the underlying anatomical structures. As such, there remains a need in the art for an improved surgical instrument that provides visual entry and visual insufflation, and that minimizes the risks of damaging organs, tissues and vessels underlying a body wall.

### SUMMARY OF THE INVENTION

**[0007]** The invention is directed to surgical instruments providing visual entry and visual insufflation with minimal risks of injury to organs, tissues and vessels underlying a body wall. It is appreciated that the concept of the invention may be applied to any surgical instrument that provides the ability to insufflate under direct vision of the site of insufflation, regardless of the size of the instrument and the type of insufflation fluid. More specifically, the surgical instrument provides the ability to transfer an insufflation fluid such as CO<sub>2</sub> or saline from outside a patient to inside a surgical cavity under vision. The insufflation fluid may be transferred inside a lumen, along a body channel or through a coiled tube of a surgical instrument or scope used for vision.

**[0008]** In a first embodiment of the invention, an insufflating surgical instrument adapted for movement across an abdominal wall to insufflate an abdominal region of a patient is disclosed comprising a shaft having an insufflation channel extending along an axis between a proximal end and a distal end, the insufflation channel being adapted for connection to a source of fluid under pressure at the proximal end. The insufflating surgical instrument further comprises a tip at the distal end of the shaft and at least one vent hole formed at the tip or the shaft being in connection with the insufflation channel and being adapted to expel the fluid under pressure to insufflate the abdominal region. In one aspect, at least one of the tip and the shaft is formed of a transparent material to facilitate visualization of the abdominal wall and the abdominal region. With this aspect, the shaft and the tip are configured to enable insertion of a laparoscope. In particular, the shaft includes a lumen extending along the axis between the proximal end and the distal end to enable insertion of the

laparoscope. The lumen and insufflation channel may be formed as separate channels or as one shared channel. The insufflating surgical instrument may further comprise a second vent hole being in connection with the insufflation channel and formed along the shaft. It is appreciated that the tip may be blunt, the shaft and the tip may be integrally formed, and the vent hole may be of any geometric shape including round, oval, square and rectangular. With this aspect, at least one of the tip and the shaft may be formed of a translucent or a transparent material such as polycarbonate. The blunt tip may further comprise a marker to indicate when the vent hole has been positioned for insufflation. More specifically, the marker indicates the point where the vent hole has penetrated the abdominal wall. The shaft of the invention may further comprise a scope lock to prevent the laparoscope from being inserted too far into the shaft and block at least one of the insufflation channel and the vent hole. In another aspect, the tip may be sharp, pointed or bladed to facilitate penetration of body tissue.

**[0009]** The insufflating surgical instrument may further comprise a seal housing disposed at the proximal end of the shaft. The seal housing comprises a septum seal and a plurality of leaflets forming an instrument seal in the presence of a laparoscope, and providing a zero seal in the absence of an instrument. The thickness of the leaflets may be formed to a desired dimension to create a pressure release mechanism that inverts and releases pressure if the abdominal pressure within the patient undergoes a sudden spike. The septum seal may be formed of an elastomeric material including Kraton, silicone and the like. The seal housing may further comprise a duckbill or a double duckbill valve distal of the leaflets to further limit gas or fluid escape.

**[0010]** In another aspect of the invention, an insufflating surgical instrument adapted for penetrating an abdominal wall to insufflate an abdominal region of a patient is disclosed comprising a shaft having an insufflation channel extending along an axis between a proximal end and a distal end, the insufflation channel being adapted for connection to a source of fluid under pressure at the proximal end. The insufflating surgical instrument further comprises a tip at the distal end of the shaft, the tip having a first, closed position during penetration of the abdominal wall and a second, opened position to expel the fluid under pressure to insufflate the abdominal region after penetration of the abdominal wall. The tip may be a flip-top that automatically opens upon traversing the abdominal wall or a flapper valve that opens to the second position when gas or fluid is introduced at the source and into the insufflation channel. The insufflating surgical instrument may further comprise a retention member for connecting the shaft and the flip-top. The flip-top may be a two-piece flip-top, the flapper valve may be a reverse flapper valve or a spring-based flapper valve, and the retention member may be one of a spring, a spring wire, an offset hinge or a living hinge. In another aspect, the tip may comprise at least two petals that reposition to the side of the shaft in the second insufflation position.

**[0011]** Another aspect of the invention is a laparoscopic insufflating surgical instrument adapted for movement across an abdominal wall to insufflate an abdominal region of a patient comprising an elongate tube having a distal tip, an insufflation channel extending between a proximal end and a distal end, the elongate tube being adapted for connection to a source of fluid under pressure at the proximal end, and being adapted at the distal end to expel the fluid under pressure to

insufflate the abdominal region, and an optical element disposed at the distal end of the elongate tube to facilitate visualization of the abdominal wall and the abdominal region. With this aspect, the distal tip is defined by a curved surface, the distal tip being translucent or transparent, and the optical element being a light or an endoscope. It is appreciated that the insufflating surgical instrument may be an insufflating Veress needle.

**[0012]** Another aspect of the invention is directed to a laparoscopic insufflating surgical instrument adapted for movement across an abdominal wall to insufflate an abdominal region of a patient comprising an elongate tube having a proximal end and a distal end, an optical element disposed at the distal end of the elongate tube to facilitate visualization of the abdominal wall and the abdominal region of the patient, and an insufflation channel having a proximal end and a distal end extending along the proximal end and the distal end of the elongate tube, the insufflation channel being adapted for connection to a source of fluid under pressure at the proximal end, and to expel the fluid under pressure to insufflate the abdominal region at the distal end. With this aspect, the insufflation channel is formed into a coil around the elongate tube. It is further appreciated that the distal end of the elongate tube may be tapered to form a generally cone-tipped end.

**[0013]** In yet another aspect of the invention, there is disclosed an insufflating surgical instrument adapted for movement across an abdominal wall to insufflate an abdominal region of a patient, the surgical instrument comprising an insufflating cannula having a wall forming a first lumen extending along an axis between a proximal end and a distal end, and a first insufflation channel formed in the wall extending along the axis between the proximal end and the distal end and being adapted for connection to a source of fluid under pressure at the proximal end. The insufflating surgical instrument further comprises an insufflating trocar having a shaft with a second lumen extending along the axis between a proximal end and a distal end, a second insufflation channel formed at the distal end and being adapted for alignment with the first insufflation channel of the cannula to expel the fluid under pressure to insufflate the abdominal region, and a tip at the distal end of the shaft, and at least one vent hole formed at the tip of the trocar being in connection with the second insufflation channel of the trocar. The insufflating surgical instrument may further comprise a laparoscope adapted for insertion at the proximal end of the trocar and advanced to the distal end as the trocar is placed through the abdominal wall.

**[0014]** Another aspect of the invention is directed to a method for using an insufflating surgical instrument to create access across an abdominal cavity and to insufflate an abdominal region of a patient, the method comprising providing a transparent shaft having a lumen and an insufflation channel extending along an axis between a proximal end and a distal end, the insufflation channel being adapted for connection to a source of fluid under pressure at the proximal end, a tip at the distal end of the shaft, and at least one vent hole formed at the tip or the shaft being in connection with the insufflation channel and adapted to expel the fluid under pressure to insufflate the abdominal region; moving the shaft across the abdominal wall to place the distal end of the shaft in the abdominal region; and expelling gas or fluid under pressure through the insufflation channel to insufflate the abdominal region of the patient. The method for using the

insufflating surgical instrument may further comprise the step of visualizing the abdominal cavity through the lumen of the shaft.

[0015] These and other features of the invention will become more apparent with a discussion of the various embodiments in reference to the associated drawings.

#### BRIEF DESCRIPTION OF THE DRAWINGS

[0016] The accompanying drawings, which are included in and constitute a part of this specification, illustrate the embodiments of the invention and, together with the description, explain the features and principles of the invention. In the drawings:

[0017] FIG. 1 illustrates a typical laparoscopic abdominal surgery of the prior art.

[0018] FIG. 2 illustrates a perspective view of an insufflation needle of the prior art.

[0019] FIG. 3 illustrates a perspective view of an insufflating optical trocar in accordance with a first embodiment of the invention.

[0020] FIGS. 4(a) and 4(b) illustrate cross-sectional views of an insufflating optical trocar in accordance with another embodiment of the invention.

[0021] FIG. 5 illustrates a perspective view of a septum seal for use with the insufflating optical trocar of the invention.

[0022] FIG. 6(a)-6(d) illustrate cross-sectional views of the septum seal for use with the insufflating optical trocar of the invention.

[0023] FIGS. 7(a) and 7(b) illustrate the insufflating optical trocar and cannula of the invention.

[0024] FIGS. 8(a)-8(f) illustrate different geometric shapes and patterns of the vent hole of the invention.

[0025] FIG. 9 illustrates an insufflating needle having a transparent distal tip and insufflating vent in accordance with another embodiment of the invention.

[0026] FIG. 10 illustrates an insufflating scope having a transparent distal tip and insufflating vent in accordance with another embodiment of the invention.

[0027] FIG. 11 illustrates an insufflating scope sleeve having a transparent distal tip and insufflating vent in accordance with another embodiment of the invention.

[0028] FIGS. 12(a)-12(f) illustrate additional tip designs of an insufflating optical surgical instrument in accordance with additional aspects of the invention.

[0029] FIGS. 13(a) and 13(b) illustrate a coiled insufflating optical trocar and a coiled insufflating optical trocar with a coiled tip, respectively, in accordance with additional embodiments of the invention.

[0030] FIGS. 14(a)-14(c) illustrate flip-top or flip-tip designs of insufflating optical surgical instruments in accordance with additional embodiments of the invention.

[0031] FIGS. 15(a)-15(c) illustrate cross-sectional views of insufflating valve vents in accordance with additional embodiments of the invention.

[0032] FIG. 16 illustrates a blunt tip insufflating optical instrument having an advanceable lumen in accordance with another embodiment of the invention.

[0033] FIGS. 17(a) and 17(b) illustrate an insufflating surgical instrument including an insufflating optical trocar and a cannula having a gas channel for transferring insufflation gas to the trocar in accordance with another embodiment of the invention.

[0034] FIG. 18 illustrates an insufflating blade actuating optical trocar in accordance with another embodiment of the invention.

[0035] FIGS. 19(a)-19(i) illustrate additional tip designs in accordance to other aspects of the invention to facilitate penetration of body tissue.

#### DETAILED DESCRIPTION OF THE INVENTION

[0036] Referring to FIG. 1, there is shown a typical laparoscopic abdominal surgery where an inflation needle 10 is inserted through a body or abdominal wall 15 and into an abdominal cavity 25. A gas is passed through the needle 10 to create a space within the abdominal cavity 25. This procedure is referred to as insufflation. The needle 10 is referred to as an insufflation needle and the gas supply is referred to as an insufflation gas. The insufflation needle 10 is placed through the body wall 15 blindly. In other words, there is no direct visualization of the procedure from the inside of the body wall 15. As explained earlier, the current procedure may inadvertently damage organs and tissues underlying the body or abdominal wall 15 such as major blood vessels and the intestinal tract. It is not uncommon for there to be internal structures attached to the internal side of the body wall 15. This is especially so in the case of the abdominal cavity 25. Portions of the intestines, colon and bowel may be attached to the abdominal wall 15. These attachments are referred to as adhesions.

[0037] Adhesions represent a potential complication in laparoscopic surgery. This is especially the case as the procedure is initiated using a sharp or pointed instrument such as the insufflation needle 10. The delicate internal structures that may be attached by adhesions may inadvertently be pierced by the introduction of the insufflation needle 10. This can be very serious and may go undetected for some time.

[0038] Referring to FIG. 2, the typical insufflation needle 10 comprises an elongate tubular body 12, a proximal connecting housing 14, a sharp, pointed distal tip 16 and a spring, biased internal blunt core 18 with a blunt end 24 that extends beyond the sharp distal tip 16 under the influence of an extended compression spring 20. A typical placement of the insufflation needle 10 requires a user to push the sharp distal tip 16 into the abdominal wall 15, which pushes the blunt core 18 proximally, then continues to push until the distal end 22 is through the body wall 15. At that point, the blunt end 24 moves forward and thereby protects delicate structures from being inadvertently punctured by the sharp distal tip 16 of the needle 10. The safety of such a device depends to a large extent on the design and integrity of the spring 20 since the sharp distal tip 16 remains within the established internal region or body cavity 25.

[0039] Referring to FIG. 3, there is shown a perspective view of an insufflating optical instrument or trocar 30 in accordance with a first embodiment of the invention. The insufflating optical trocar 30 is designed to separate tissue fibers during insertion through the body wall 15. The insufflating optical trocar 30 includes a shaft 34 having a lumen extending substantially along an axis between a proximal end and a distal end, a handle 35 disposed at the proximal end of the shaft 34, and a blunt tip 32 disposed at the distal end of the shaft 34. The shaft 34 of the insufflating optical trocar 30 is sized and configured for disposition within a working channel of a cannula system as described in co-pending application Bladeless Optical Obturator, which is herein incorporated by reference. With this disposition, the insufflating optical trocar

**30** functions to penetrate a body or abdominal wall to provide the cannula with access across the body wall **15** and into the body cavity **25**, such as the peritoneal or abdominal cavity.

[0040] In one aspect of the invention, the shaft **34** and tip **32** are integrally formed of a transparent material to enable visualization of tissue during the insertion of the insufflating optical trocar **30** through the body wall **15**. The insufflating optical trocar **30** is configured to enable the insertion of a conventional laparoscope, which typically includes an imaging element and fiber optic light fibers. The tip **32** further includes at least one vent hole **36**, and preferably two or more vent holes one on each side of the tip **32**, for the insufflation gas to transfer from the inside of the trocar **30** into the body or abdominal cavity **25**. The vent hole **36** may be chamfered on the proximal side such that the vent hole does not core tissue as the insufflating optical trocar **30** enters through the body wall **15**.

[0041] The shaft **34** includes at least one shaft vent **38** and preferably a plurality of shaft vents **38** along the axis between the proximal end and the distal end. It is appreciated that vent holes **36** and shaft vents **38** may be of any geometric shape including round, oval, square, rectangular, etc., as illustrated in FIGS. **8(a)**-**8(c)** and may be configured in different patterns such as a waffle pattern as illustrated in FIG. **8(f)**. Furthermore, the tip **32** may be an open tip **180** or a non-coring tip **182** as illustrated in FIGS. **8(d)** and **8(e)**, respectively, to allow the transfer of insufflation gas into the body cavity **25**. Advantages of the shaft vents **38** include supporting a plurality of core pins during the injection molding process of the shaft **34** to provide a uniform part thickness, and allowing the insufflation gas to transfer from the inner diameter of the cannula and seal housing into the inner diameter of the insufflating optical trocar **30** and consequently out of the vent holes **36** at tip **32**.

[0042] Referring to FIGS. **4(a)** and **4(b)**, there are shown side cross-sectional views of an insufflating optical trocar **40** in accordance with another embodiment of the invention. The insufflating optical trocar **40** includes a shaft **34b** having a lumen extending substantially along an axis between a proximal end and a distal end, and a blunt tip **32b** disposed at the distal end. The insufflating optical trocar **40** further includes at least one gas channel **42** extending along the length of the shaft **34b** to provide rapid gas transfer through the insufflating optical trocar **40** when a scope has been placed within the inner diameter. It is appreciated that there may be more than one gas channel **42** extending along the length of the shaft **34b** to provide rapid gas transfer through the trocar **40**. It is further appreciated that the gas channel **42** may be formed as a separate channel or as the same channel for inserting the scope, that is, by increasing the inner diameter of the shaft **34b** to be bigger than the diameter of the scope. More specifically, even if the scope and gas share the same channel, the gas channel **42** assures that there is sufficient cross-sectional area for the gas to travel along the side of the scope and down to the vent hole(s) **36b** even when the scope is in place.

[0043] The tip **32b** may further include a marker **46** to be used as a visible reference point. The marker **46**, together with an area indicated by reference number **44** as shown in FIG. **4A**, depict the down vent of the insufflating optical trocar **40** that transfers the gas from the gas channel **42** of the trocar **40** to the vent holes **36b** at tip **32b**. For example, as the trocar **40** is being placed through the abdominal wall **15**, at some point the tip **32b** of the trocar **40** will penetrate the peritoneum. Once the peritoneum can be seen through the tip **32b** and once

the peritoneum is above the visible marker **46**, the insufflation gas can be turned on and insufflation can begin. As such, this marks the point where the vent hole **36b** is within the abdominal cavity. Once the insufflation gas has created sufficient space between the abdominal wall and the organ bed, the remainder of the insufflating optical trocar **40** including the cannula system can then be fully inserted to an operative position.

[0044] The insufflating optical trocar **40** may further include a scope stop **48** as illustrated in FIG. **4(b)** to keep a scope from being inserted into the taper of the inner diameter of the trocar **40**. The scope stop **48** may further include a ledge that further prevent the possibility of the scope from being inserted too far into the trocar and consequently block the distal portion of the gas channel **42**.

[0045] Referring to FIG. **5**, there is shown a perspective view of a septum seal **50** to be used with the insufflating optical trocar of the invention. The septum seal **50** includes a tubular body **52**, a septum ring **53** and a plurality of leaflets **54** formed by a slit **56** providing an instrument seal when a scope is inserted into the insufflating optical trocar and a zero seal when the scope is withdrawn from the trocar. In addition, the thickness of the leaflets **54** can be controlled such that a pressure release mechanism can be created and consequently allowing the leaflets **54** to invert and release pressure if the abdominal pressure within the patient undergoes a sudden spike. Referring to FIGS. **6(a)**-**6(d)**, there are shown cross-sectional views of the septum seal **50** of FIG. **5**. The septum seal **50** further includes a retaining ledge **58**, which allows the septum seal **50** to be attached to the cap or handle **35** of the insufflating optical trocar, and also serves as a sealing surface. Reference number **59** illustrates a sealing surface between the septum seal **50** and the cap or handle of the insufflating optical trocar. The septum seal **50** may further comprise a duckbill or double duckbill valve placed distally of the leaflets **54** to further limit gas or fluid escape.

[0046] During use, the insufflating optical trocar **30** is first inserted into a seal housing **84** and cannula **70** as illustrated in FIG. **7(a)**. A conventional laparoscope **72** is then inserted into the proximal end of the insufflating optical trocar **30** and advanced to the distal end of the trocar **30**. An endoscopic video camera is attached to the proximal end of the laparoscope **72**. The trocar **30** is then axially advanced by the surgeon through the body wall **15**. As the surgeon advances the cannula **70** and trocar **30** through the body wall **15**, the surgeon can visually observe tissue of the body wall **15** as it is being separated via a video monitor, which is connected to the endoscopic video camera. The surgeon can also readily determine when the body wall **15** has been completely traversed by the trocar **30**. Once the trocar **30** has traversed the body wall **15**, the trocar **30** and laparoscope **72** may be removed which leaves the cannula **70** disposed across the body wall **15** to provide an access channel into the body cavity **25** for the insertion of laparoscopic instrumentation.

[0047] As illustrated in FIG. **7(a)**, the insufflating optical trocar **30** is designed for use with the seal housing **84** and cannula **70**. The tip **32** may be blunt and does not include any sharp edges, piercing points or blades. With this aspect of the invention, the tip **32** of the bladeless insufflating optical trocar **30** is transparent and generally hollow. This enables a clear view through the distal tip of the insufflating optical trocar **30** and increases the visibility of tissue as it is being traversed. The obturator shaft **34** with the integral tip **32** may be formed of a transparent material such as polycarbonate. The septum

seal **50**, which may be formed of a material such as Kraton, silicone and the like, may be snap fitted onto the proximal end of the obturator shaft **34**. The seal housing **84** may further include a handle attachment **35** including a cannula seal, which may be formed of a plastic material such as polycarbonate, that operates to attach the trocar **30** to the cannula **70** so as to maintain axial position during insertion. The diameter of the shaft **34** can range from about 2 mm to 50 mm and is designed to fit within the seal housing **84** and cannula **70**.

[0048] Referring to FIG. 7(b), the cannula **70** is designed to releasably attach to the seal housing **84** via cannula seal **80a**, **80b**. As the shaft **34** is inserted into the seal housing **84** and cannula **70**, the cannula seal **80a**, **80b** passively engages the seal housing **84** and serves to axially lock the shaft **34** to the seal housing **84** and cannula **70**. To release the shaft **34** from the seal housing **84** and cannula **70**, outboard tabs on shaft **34** are depressed inwardly and the shaft **34** is then free to be slidably removed. The shaft **34** includes axial key members **37** (see FIG. 3) at its proximal end which are designed to mate with axial keyways on the seal housing **84**. As the shaft **34** is inserted into the seal housing **84** and cannula **70**, the shaft **34** is rotated slightly to align key members **37** with the keyways and then advanced until the cannula seal **80a**, **80b** engages the seal housing **84**. The key members **37** serve to rotationally index the shaft **34** to the seal housing **84**. In another aspect, cannula **70** may further include distal cannula seal **82** formed at a distal portion of cannula **70** and shaft **34** so as to further limit gas or fluid escape.

[0049] In another aspect of the invention, the insufflating optical trocar **30** may include a laparoscope lock **86** having an elastomeric element. The addition of the elastomeric element would enhance the frictional engagement with the laparoscope **72**. An example of an elastomeric element would be a silicone O-ring sized with an inside diameter smaller than the outside diameter of the laparoscope **72**. The laparoscope lock **86** could either rotate freely to enable the laparoscope **72** to rotate freely relative to the shaft **34** or the laparoscope lock **86** could be rotationally fixed to prevent the laparoscope **72** from rotating relative to the shaft **34**.

[0050] In another aspect of the invention, a process of placing and using the insufflating optical trocar of the invention is described. First, the skin around the area to be operated on is incised appropriately for the size of the cannula **70**. An insufflation gas line **90**, which is attached to the seal housing **84**, the insufflating optical trocar **30** and the laparoscope **72** are then inserted into the cannula **70**. At this point the gas supply is still turned off. The assembled device is then advanced through the body or abdominal wall **15** under direct vision until it is observed that just the tip **32** of the device has penetrated the peritoneal cavity. The device is then held in place and the flow of insufflation gas is begun. The gas will flow through the tip **32** and into the peritoneal cavity until the cavity is sufficiently distended by gas pressure. The surgeon then completes the insertion of the insufflating optical trocar **30** until the cannula **70** is in an appropriate or desired position. The insufflating optical trocar **30** and laparoscope **72** may then be removed. At this point, the surgeon may elect to reinsert just the laparoscope **72** through the seal housing **84** and thereby allow observation of the abdominal cavity and subsequent insertions of additional laparoscopic instrumentation.

[0051] As explained earlier, an indicator line or marker **46** as shown in FIG. 4(a) may be located on tip **32** to be viewed by laparoscope **72** to indicate when the device has advanced

far enough into the body cavity to begin insufflation. The coincidence of anatomical features with the indicator line or marker **46** may indicate the correct position to begin insufflation. The indicator line or marker **46** could be circumferential in nature and when the peritoneal layer, as it is being penetrated, forms a coincident circle with respect to the indicator line **46**, the surgeon can begin insufflating. Another method is to employ an O-ring seal **86**. Additionally, it is preferred that a zero seal be present on the trocar to prevent escape of the gas when the trocar is used to place cannulas without the laparoscope **72**. A double duckbill valve **88** would work well too for this application as would a single duckbill, a flapper valve or a slit valve.

[0052] It is appreciated that the above-described concept may be applied to any surgical instruments providing visual entry and visual insufflation, regardless of size or type of fluid transfer as further described in the following exemplary embodiments of the invention. For example, FIG. 9 illustrates an insufflating needle **190** in accordance with another aspect of the invention comprising an elongate tubular body **192** having an insufflation channel extending along an axis between a proximal end and a distal end, a transparent distal tip **194** operably attached to the distal end of the tubular body **192**, and at least one insufflating vent hole **196** formed at the distal tip **194** or tubular body **192** and being in connection with the insufflation channel. The insufflating needle **190** may further include an insufflation-controlling device **198** such as a stopcock and a sealing mechanism **200** at the proximal end of the tubular body **192**. A small diameter scope **202** may be inserted at the proximal end of the tubular body **192** and then advanced to the distal end of the tubular body **192** as the insufflating needle **190** such as an insufflating Veress needle is placed through an abdominal wall. In yet another aspect of the invention as illustrated in FIG. 10, an insufflating scope **210** comprises an elongate body **212** having an insufflation channel **224** extending along an axis between a proximal end and a distal end, a transparent tip **214** operably attached to the distal end of the elongate body **212** and having at least one insufflating vent hole **216** being in connection with the insufflation channel **224**, and a handle **218** formed at the proximal end of the elongate body **212**. The insufflating scope **210** may further include an insufflation-controlling device **220** such as a stopcock at the proximal end of the elongate body **212** or on the handle **218**. The elongate body **212** includes an optical element **222** that directs light to the tip **214** and at least one insufflation channel **224** to transfer the insufflation gas into the surgical cavity.

[0053] Referring to FIG. 11, there is shown an insufflating scope sleeve **230** in accordance with another embodiment of the invention. The insufflating scope sleeve **230** comprises a flexible sleeve **232** having a proximal end and a distal end, a transparent tip **234** operably attached to the distal end of the flexible sleeve **232** and having at least one insufflating vent hole **236**, and a handle **238** attached to the proximal end of the flexible sleeve **232**. The insufflating sleeve **230** may further include an insufflation-controlling device **240** such as a stopcock and a sealing mechanism **242** at the proximal end of the insufflating sleeve **230**. A scope **244** may be inserted at the proximal end of the insufflating scope sleeve **230** and then advanced to the distal end of the insufflating scope sleeve **230** as the insufflating scope sleeve **230** is placed through an abdominal wall.

[0054] Referring to FIGS. 12(a)-12(f), there are shown additional tip designs **32o-32s** in accordance with other

aspects of the invention to facilitate penetration of a body tissue. FIG. 12(a) illustrates a spoon-shaped or asymmetric tip 32o having at least one vent hole 36o; FIGS. 12(b) and 12(c) illustrate a generally domed or conical shaped tip 32p having plastic or metal blades 33p along an axis of the shaft and at least one vent hole 36p; FIG. 12(d) illustrates a blunt tip 32q having at least one vent hole 36q; FIG. 12(e) illustrates a generally domed or conical shaped tip 32r having at least one bladed fin 33r and at least one vent hole 36r; and FIG. 12(f) illustrates a generally conical shaped tip 32s having at least one vent hole 36s at the distal tip. It is appreciated that tips 32o, 32p, 32r and 32s have a sharp, pointed or bladed tip and/or edge to facilitate penetration of body tissue. In yet other aspects of the invention, the surface of the tip may have at least one tissue engaging raised pattern on the surface. The surface operates to facilitate insertion of the insufflating surgical instrument or optical trocar with a reduced penetration force and minimize tenting of the body wall. The surface may further facilitate separation of different layers of the body wall and provides proper alignment of the tip between the layers. In another aspect of the invention, the tip may have an outer surface extending distally to a blunt point and includes a pair of side sections separated by an intermediate section, and wherein the side sections extend from the blunt point radially outwardly with progressive positions proximally along the axis. The side sections may include a distal portion in proximity to the blunt point and a proximal portion in proximity to the tubular body, and the distal portion of the side sections being twisted radially with respect to the proximal portion of the side sections.

[0055] FIGS. 13(a) and 13(b) illustrate a coiled insufflating optical trocar 250 and a coiled insufflating optical trocar with a coiled tip 260, respectively, in accordance with additional embodiments of the invention. The coiled insufflating optical trocar 250 comprises a shaft 34t having a lumen and a hollow coiled tube or gas channel 42t wrapped substantially along the length of the shaft 34t to provide gas transfer into the body cavity. An advantage of this aspect of the invention is coiling also helps to keep the trocar from moving about inside a body cavity. The coiled insufflating optical trocar 250 may further include an insufflation-controlling device 240 such as a stop-cock at the proximal end of the coiled insufflating optical trocar 250. A scope may be inserted at the proximal end of the coiled insufflating optical trocar 250 and then advanced to the distal end of the trocar 250 as the trocar 250 is placed through an abdominal wall. The coiled insufflating optical trocar with coiled tip 260 as shown in FIG. 13(b) is similar to the coiled insufflating optical trocar 250 but further includes a tip 32u and a hollow coiled tube or gas channel 42u that wraps around the tip 32u and substantially along the length of the shaft 34u.

[0056] Referring to FIGS. 14(a)-14(c), there are shown additional tip designs 32v-32x in accordance to other aspects of the invention. For example, the tip 32v as illustrated in FIG. 14(a) comprises a flip-top 272 and a conical body 270 that operates to move from a first, penetrating position to a second, insufflating position when the body wall has been traversed. The tip 32v may further comprise a retention member for connecting the flip-top 272 and the conical body 270. The retention member may be one of a spring, a spring wire, an offset hinge or a "living" hinge. Other flip-top or flip-tip designs as described in co-pending U.S. patent application Ser. No. 10/805,864, entitled "Surgical Access Port and Method of Using Same," filed Mar. 22, 2004, which is herein incorporated by reference, may also be used with the insuff-

flating concept of the invention. In yet another aspect of the invention, the tip 32w as illustrated in FIG. 14(b) comprises a two-piece flip-top 282a, 282b that operates to move from a first, penetrating position to a second, insufflating position when the body wall has been traversed. In particular, the tip 32w may comprise at least two or more parts or petals that reposition to the side of the shaft 34w in the second, insufflating position. FIG. 14(c) illustrates the tip 32x in accordance with another aspect of the invention comprising a two-stage flip-top 290 that operates to move from a penetrating position to an insufflating position and then to an instrument access position. In particular, the two-stage flip-top 290 comprises a distal flip portion 292 and a proximal flip portion 294. In the first stage, the distal flip portion 292 moves from a penetrating position to an open or insufflating position once the body wall has been traversed. Once insufflation has been achieved, the proximal flip portion 294 moves to an open or instrument access position in the second stage. The tip 32x may further comprise retention members for connecting between the distal flip portion 292 and the proximal flip portion 294, and between the proximal flip portion 294 and the shaft 34x.

[0057] FIGS. 15(a)-15(c) illustrate insufflating valve vents in accordance with additional aspects of the invention. More specifically, FIG. 15(a) illustrates an insufflating valve vent 300 formed at the distal end of the shaft 34. The insufflating valve vent 300 is formed of an elastic material to allow gas such as CO<sub>2</sub> to be introduced from the inside of the shaft 34 to a body cavity. It is appreciated that when there is no gas, the elastic material of the insufflating valve vent 300 causes it to close so as to provide an airtight seal. FIG. 15(b) illustrates an insufflating flapper valve 310 formed at tip 32y of an insufflating optical trocar. The insufflating flapper valve 310 comprises at least one flapper valve vent 312 that operates to open when a gas such as CO<sub>2</sub> is introduced in the shaft 34. It is appreciated that when there is no gas, the flapper valve vent 312 closes to provide a tight seal. Similarly to FIG. 15(b), FIG. 15(c) illustrates an insufflating reverse flapper valve 320 formed at tip 32z of an insufflating optical trocar. The insufflating reverse flapper valve 320 comprises at least one flapper valve vent 322 that remains close or shut by tissue during insertion, and once peritoneum is passed, pressure by a gas such as CO<sub>2</sub> would then open the reverse flapper valve 320 to allow the transfer of the gas into a body cavity. It is appreciated that each of the above flapper valve vents may be spring loaded to operate like a Veress needle.

[0058] FIG. 16 illustrates a blunt tip insufflating optical instrument 400 in accordance with another embodiment of the invention. The blunt tip insufflating optical instrument 400 comprises an elongate tubular body 410 extending along an axis between a proximal end and a distal end, a blunt tip optical obturator or separator 420 to be inserted through the tubular body 410 and into a body cavity, and an advanceable insufflation channel 430 extending along the length of the tubular body 410 and into the body cavity. The blunt tip optical obturator or separator 420 operates to provide visibility down to the peritoneum at which time the insufflation channel 430 may be advanced through the peritoneum to provide gas and/or saline to the body cavity until sufficient space is achieved. Once gas and/or saline have been sufficiently introduced, the blunt tip optical obturator 420 and tubular body 410 may be advanced into the body cavity. A feature of this aspect of the invention is the insufflation channel 430 may be advanced ahead of the blunt tip optical obtu-

rator or separator **420** to puncture peritoneum to transfer gas such as CO<sub>2</sub> to the body cavity.

**[0059]** Referring to FIGS. **17(a)** and **17(b)**, there are shown illustrations of an insufflating surgical instrument **500** in accordance with another embodiment of the invention. The insufflating surgical instrument **500** comprises an insufflating optical trocar **502** and a cannula **520**. The insufflating optical trocar **502** comprises a shaft **504** having a lumen extending along an axis between a proximal end and a distal end, a tip **506** disposed at a distal end of the shaft, at least one vent hole **508** to introduce gas from the cannula **520** into the body or abdominal cavity as further discussed below, and a gas channel **510** formed in either the shaft **504** or the tip **506** and operably connected to the at least one vent hole **508** to allow gas transfer from the cannula **520** to the insufflating optical trocar **502**. The cannula **520** comprises at least one cannula gas channel **522** extending along its longitudinal axis to transfer gas to the trocar gas channel **510** after insertion of the insufflating optical trocar **502** into the cannula **520**. In other words, the cannula gas channel **522** is encased as a lumen in the cannula wall. During operation, the transfer of gas only takes place if there is an alignment between the cannula gas channel **522** and the trocar gas channel **510** as illustrated in FIGS. **17(a)** and **17(b)**. A scope **525** may be inserted at the proximal end of the insufflating optical trocar **502** and then advanced to the distal end of the trocar **502** as the trocar **502** is placed through an abdominal wall.

**[0060]** In yet another aspect of the invention, FIG. **18** illustrates an insufflating blade actuating optical instrument **600** in accordance with another embodiment of the invention. The insufflating blade actuating optical instrument **600** comprises an elongate tubular member **602** extending along a longitudinal axis between a proximal end and a distal end, an optical member **604** operably attached at the distal end of the elongate member **602**, at least one blade member **606** being longitudinally movable between deployed and nondeployed positions, an actuating mechanism **608** operably attached at the proximal end of the tubular member **602** for moving the blade member **606** between the deployed and nondeployed positions, and at least one insufflating vent **610** formed in the optical member **604** to transfer insufflation gas from outside a body cavity to inside the body cavity. A scope may be inserted at the proximal end of the insufflating blade actuating optical instrument **600** and then advanced to the distal end of the instrument **600** as the insufflating blade actuating optical instrument **600** is placed through an abdominal wall.

**[0061]** Referring to FIGS. **19(a)**-**19(i)**, there are shown additional tip designs **32aa**-**32ii** in accordance to other aspects of the invention to facilitate penetration of a body tissue. Each of these tip designs includes at least one vent hole (**36aa**-**36ii**) at the distal tip to introduce insufflation gas into a body cavity. It is appreciated that some of these tips have a sharp, pointed or bladed tip and/or edge to facilitate penetration of body tissue.

**[0062]** It is appreciated that the above described surgical instruments and devices can be used to access not only the peritoneal cavity but can be used for preperitoneal hernia repair, retroperitoneal operations including back and kidney operations, percutaneous kidney operations, thoracic surgery and arthroscopic access. In addition to gas such as carbon dioxide, it is appreciated that other fluids such as air, water and saline can also be introduced into a body cavity with the technique of the invention. It is appreciated that operating scopes may be modified such that a lumen may be used to

introduce insufflation fluid. Accordingly, it is understood that many other modifications can be made to the various disclosed embodiments without departing from the spirit and scope of the invention. For these reasons, the above description should not be construed as limiting the invention, but should be interpreted as merely exemplary embodiments.

1. A surgical instrument, comprising:
  - an elongate tube forming a lumen and having a proximal end and a distal end; the elongate tube being connectable at the proximal end to a source of fluid under pressure and configured to deliver the fluid under pressure into the lumen of the elongate tube;
  - a transparent tip enclosing the distal end of the elongate tube; the tip being configured to penetrate tissue;
  - a vent hole formed in the transparent tip;
  - an insufflation channel having a proximal end and a distal end extending along the elongate tube, the insufflation channel being adapted for channeling the fluid under pressure along the elongate tube from the proximal end and out the vent hole in the transparent tip at a point of insufflation at the distal end; and
  - an optical element disposed at the distal end of the elongate tube configured for visualization through the tip from inside the lumen.
2. The surgical instrument of claim 1 further including a cannula having a lumen and configured such that the elongate tube is insertable into the lumen of the cannula.
3. The surgical instrument of claim 1 wherein the insufflation channel is formed into a coil around the elongate tube.
4. The surgical instrument of claim 1 wherein the distal end of the elongate tube is tapered to form a generally cone-shaped tip.
5. The surgical instrument of claim 1 wherein the elongate tube is configured to enable insertion of a laparoscope into the elongate tube.
6. The surgical instrument of claim 1 wherein the insufflation channel and lumen of the elongate tube are formed as separate channels.
7. The surgical instrument of claim 1 wherein the insufflation channel and lumen of the elongate tube are formed as one shared channel.
8. The surgical instrument of claim 1 further including at least one vent hole being in connection with the insufflation channel and formed in the elongate shaft.
9. The surgical instrument of claim 1 wherein the optical element is configured for visualization of the point of insufflation.
10. The surgical instrument of claim 1 wherein the optical element is a light or endoscope.
11. A surgical instrument, comprising:
  - an elongate tube forming a lumen having a proximal end and a distal end; the elongate tube being connectable at the proximal end to a source of fluid under pressure and configured to deliver the fluid under pressure into the lumen of the elongate tube;
  - a transparent tip enclosing the distal end of the elongate tube; the tip being configured to penetrate tissue such that the tip includes a distal most portion that creates a point of tissue penetration;
  - a vent hole formed in the transparent tip in the location of the point of tissue penetration;
  - an insufflation channel having a proximal end and a distal end extending along the elongate tube, the insufflation channel being adapted for channeling the fluid under

pressure along the elongate tube from the proximal end and out the vent hole in the transparent tip at a point of insufflation at the distal end.

**12.** The surgical instrument of claim **11** further including an optical element disposed at the distal end of the elongate tube configured for visualization through the tip from inside the lumen.

**13.** The surgical instrument of claim **11** wherein the transparent tip includes a cross-sectional area that increases with increasingly proximal cross-sections taken perpendicular to a longitudinal axis of the elongate tube.

**14.** The surgical instrument of claim **11** wherein the transparent tip includes a pair of side sections separated by an intermediate section.

**15.** A method for penetrating an abdominal wall and insufflating an abdominal region of a patient, comprising:

placing an elongate tube having a tissue penetrable tip substantially perpendicular to the abdominal region of a patient such that the tip is in contact with tissue; the elongate tube forming a lumen and having a proximal end and a distal end; the elongate tube being connectable at the proximal end to a source of fluid under pressure; the elongate tube configured to deliver the fluid under pressure into the lumen of the elongate tube; wherein the tip of the elongate tube is transparent and encloses the distal end of the elongate tube; the elongate tube having a vent hole formed in the transparent tip; the elongate tube further including an insufflation channel having a proximal end and a distal end extending along the elongate tube, the insufflation channel being in connection with the vent hole and adapted for channeling the fluid under pressure along the elongate tube from the proximal end and out the vent hole in the transparent tip at a point of insufflation;

connecting the proximal end of the elongate tube to a source of fluid under pressure;

observing the point of penetration through the lumen of the elongate tube;

moving the elongate tube to penetrate the abdominal wall; ceasing moving the elongate tube of the abdominal wall when the vent hole in the transparent tip is observed from inside the lumen of the elongate tube to be just distal of the peritoneum;

expelling fluid under pressure from the source of fluid through the insufflation channel and out the vent hole to insufflate the abdominal cavity following the step of ceasing moving;

observing the point of insufflation through the lumen of the elongate tube with the scope;

insufflating the abdominal cavity with fluid delivered through the elongate tube; and

distending the abdominal cavity with the fluid.

**16.** The method of claim **15** wherein the steps of observing the point of penetration and the point of insufflation include observing through an optical element disposed at the distal end of the elongate tube.

**17.** The method of claim **15** further including the step of inserting the elongate tube into a cannula.

**18.** The method of claim **15** further including the step of holding the elongate tube in place during the expelling of the fluid.

**19.** The method of claim **15** further including the step of advancing the elongate tube into the insufflated cavity after the abdominal cavity is sufficiently distended to receive the elongate tube without damage to surrounding tissue.

**20.** The method of claim **15** further including the step of inserting a scope into the lumen of the elongate tube and moving the scope inside the lumen of the elongate tube to the distal end; and

wherein the step of observing the point of penetration includes observing the point of penetration with the scope inserted into the elongate tube and moved to the distal end of the elongate tube.

\* \* \* \* \*

专利名称(译)	充气光学手术器械		
公开(公告)号	<a href="#">US20120123202A1</a>	公开(公告)日	2012-05-17
申请号	US13/356260	申请日	2012-01-23
[标]申请(专利权)人(译)	应用医疗资源		
申请(专利权)人(译)	应用医疗资源CORPORATION		
当前申请(专利权)人(译)	应用医疗资源CORPORATION		
[标]发明人	ALBRECHT JEREMY J BRUSTAD JOHN R TAYLOR SCOTT V JOHNSON GARY M HILAL NABIL		
发明人	ALBRECHT, JEREMY J. BRUSTAD, JOHN R. TAYLOR, SCOTT V. JOHNSON, GARY M. HILAL, NABIL		
IPC分类号	A61B1/06 A61M13/00 A61B1/018 A61B17/34 A61B19/00		
CPC分类号	A61B17/3417 A61B17/3462 A61B17/3474 A61B2017/349 A61B19/5212 A61B2017/3454 A61B2017/346 A61B17/3494 A61M13/003 A61B1/06 A61B90/361 A61M2202/0007 A61M2202/02 A61M2202/0468 A61M2205/3337		
优先权	60/584302 2004-06-29 US		
其他公开文献	US9155558		
外部链接	<a href="#">Espacenet</a> <a href="#">USPTO</a>		

摘要(译)

本发明公开了一种吹气手术器械，其适于穿过腹壁移动以吹入患者的腹部区域。该器械包括轴，该轴具有在近端和远端之间延伸的注气通道，注气通道适于连接到近端压力下的流体源。尖端位于远端，并且在尖端中形成通气孔，该通气孔与吹气通道连接并适于在压力下排出流体以吹入腹部区域。尖端由透明材料形成，以便于腹壁和区域的可视化。轴包括在近端和远端之间沿轴线延伸的内腔，以便能够插入腹腔镜。内腔和吹入通道可以形成为单独的通道或一个共用通道。

