



US 20050250980A1

(19) **United States**

(12) **Patent Application Publication** (10) **Pub. No.: US 2005/0250980 A1**

Swanstrom et al.

(43) **Pub. Date: Nov. 10, 2005**

(54) **METHODS FOR PERFORMING GASTROPLASTY**

(52) **U.S. Cl.** **600/37; 623/23.65; 128/898**

(75) **Inventors:** Lee L. Swanstrom, Portland, OR (US);
Richard C. Ewers, Fullerton, CA (US);
Tracy D. Maahs, Rancho Santa Margarita, CA (US); Eugene G. Chen, Carlsbad, CA (US); Vahid Saadat, Saratoga, CA (US)

(57) **ABSTRACT**

The present invention provides methods for performing gastroplasty by reducing the effective volume or cross-sectional area of the stomach via approximation of gastric tissue. Such reduction preferably is achieved endoluminally, either with or without laparoscopic ports. In one variation, a sleeve, pouch, Magenstrasse and Mill, Vertical Banded Gastroplasty ("VBG"), etc., is formed within the stomach by approximating opposing anterior and posterior segments or ridges of the stomach wall at locations inferior to the gastroesophageal junction. In another variation, opposing walls of the stomach are approximated at a plurality of substantially random locations to reduce an effective volume of the stomach. In yet another variation, both a sleeve and random approximations are formed, the random approximations preferably disposed in a portion of the stomach excluded by the sleeve. In still another variation, opposing walls of the stomach are approximated over significant lengths at random or specified locations.

Correspondence Address:
TOWNSEND AND TOWNSEND AND CREW, LLP
TWO EMBARCADERO CENTER
EIGHTH FLOOR
SAN FRANCISCO, CA 94111-3834 (US)

(73) **Assignee: USGI Medical Corp.**

(21) **Appl. No.: 10/841,233**

(22) **Filed: May 7, 2004**

Publication Classification

(51) **Int. Cl.⁷** **A61F 2/04**

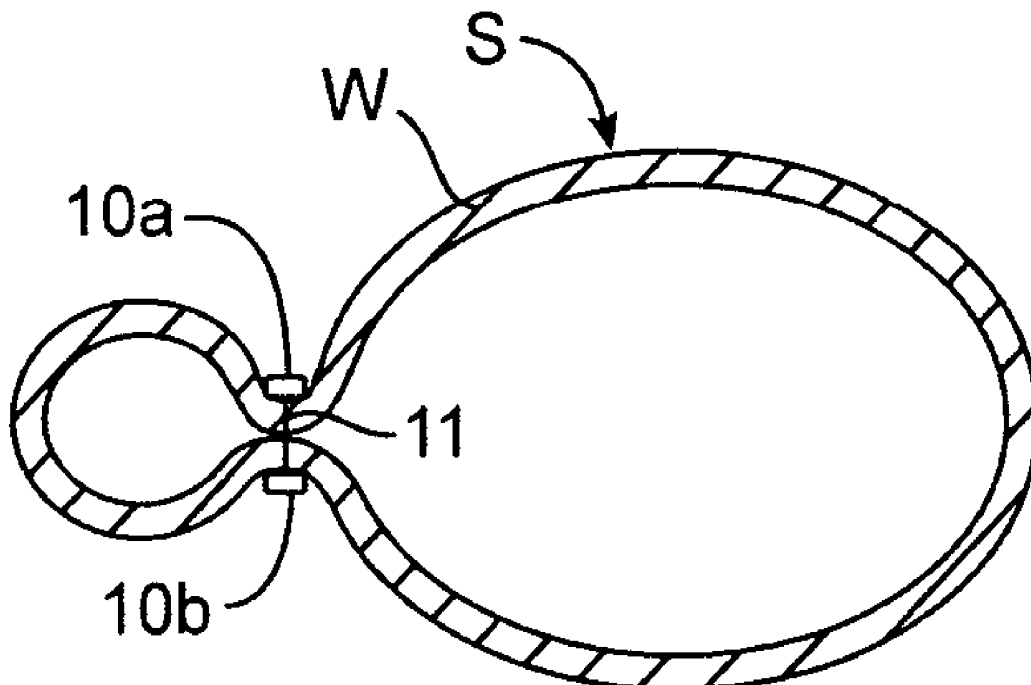

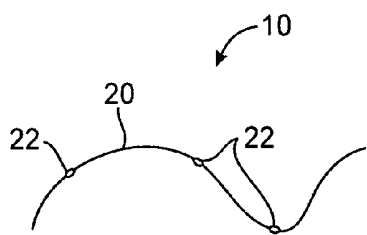

FIG. 1A

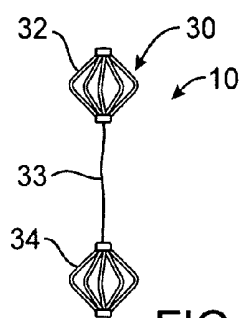

FIG. 1B

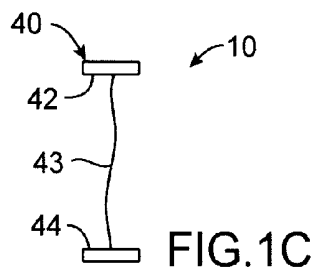

FIG. 1C

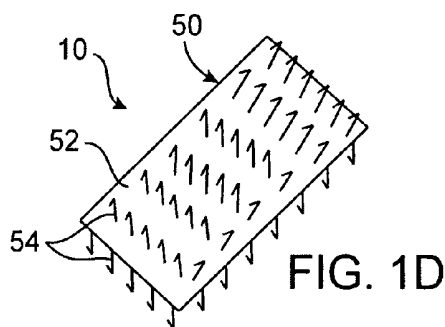

FIG. 1D

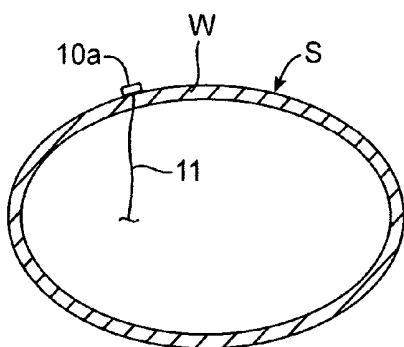

FIG. 2A

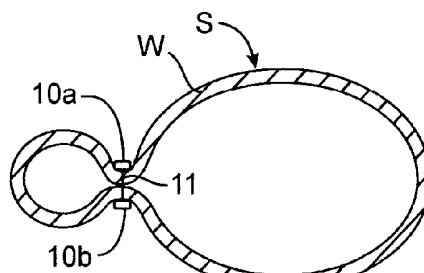

FIG. 2C

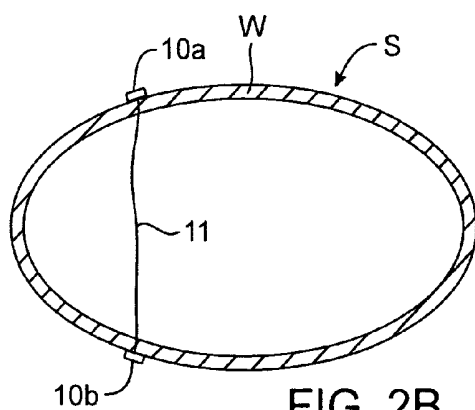

FIG. 2B

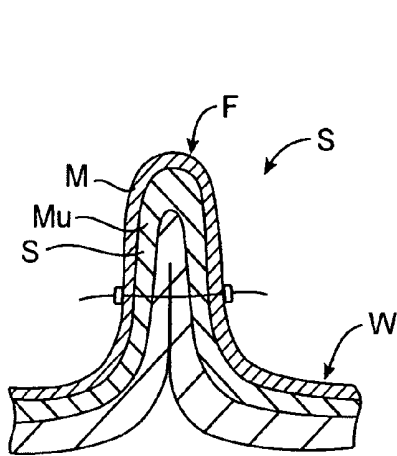

FIG. 3

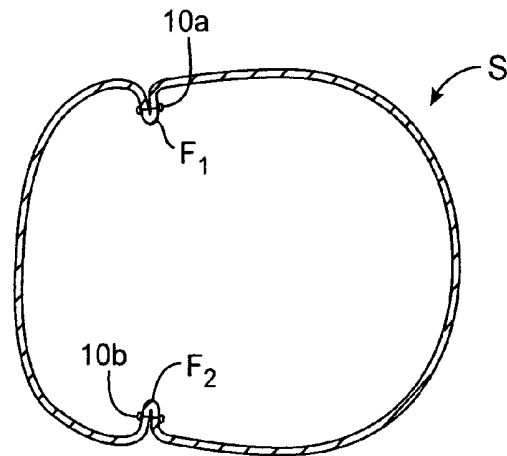

FIG. 4A

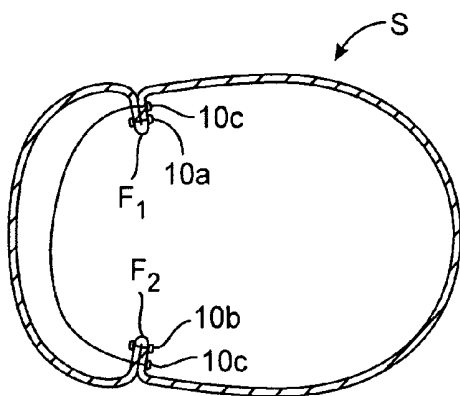

FIG. 4B

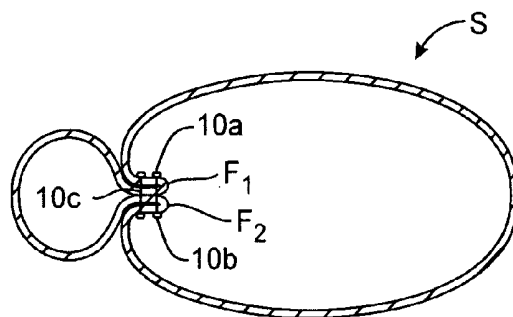

FIG. 4C

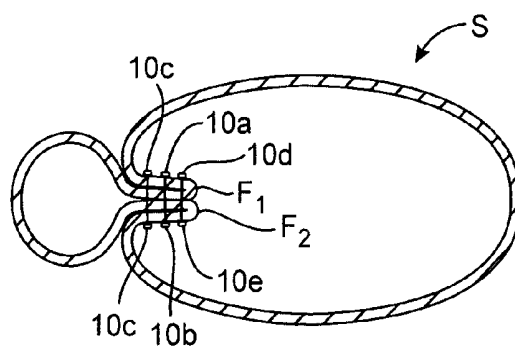

FIG. 4D

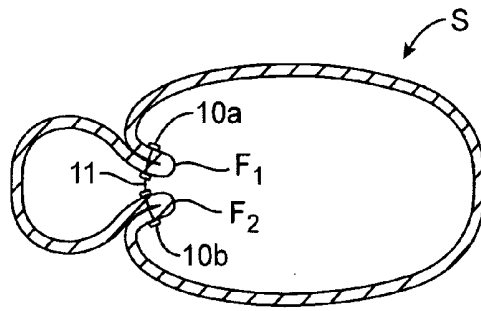

FIG. 5

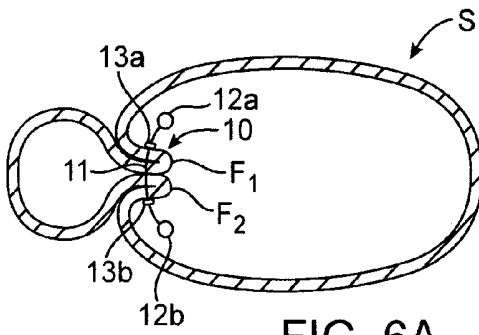

FIG. 6A

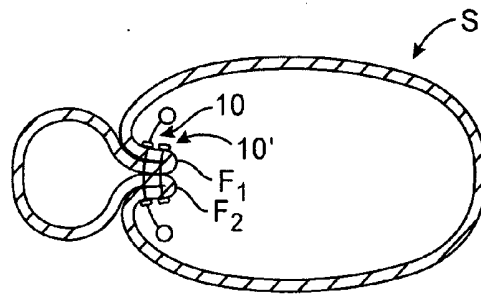

FIG. 6B

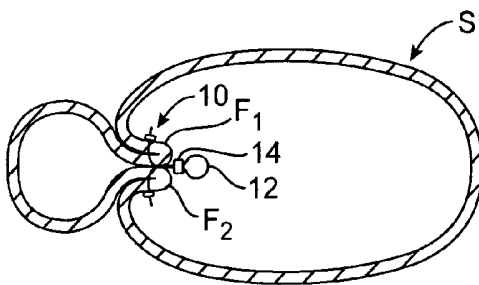

FIG. 7

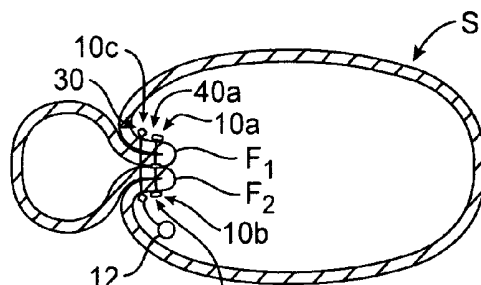

FIG. 8

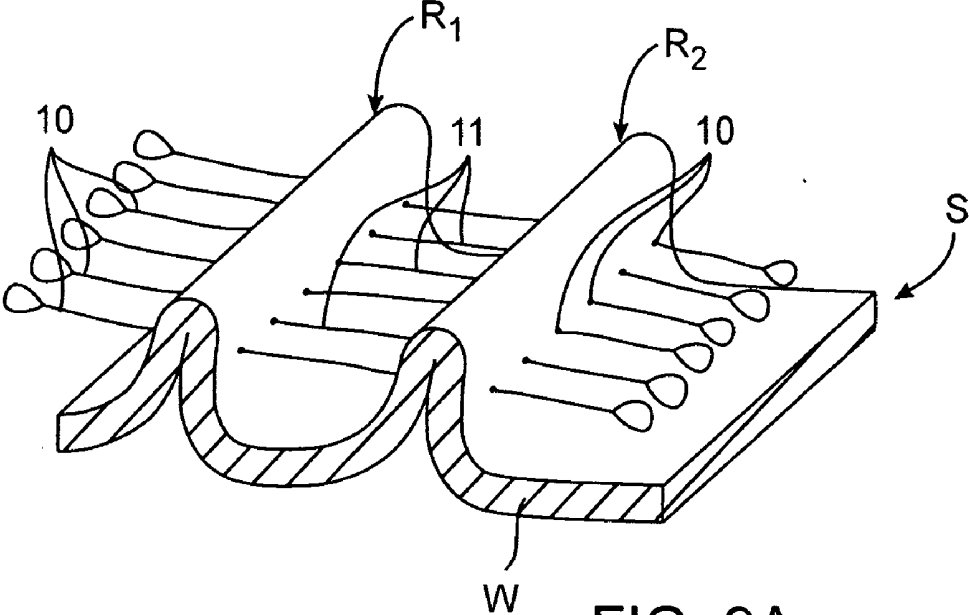

FIG. 9A

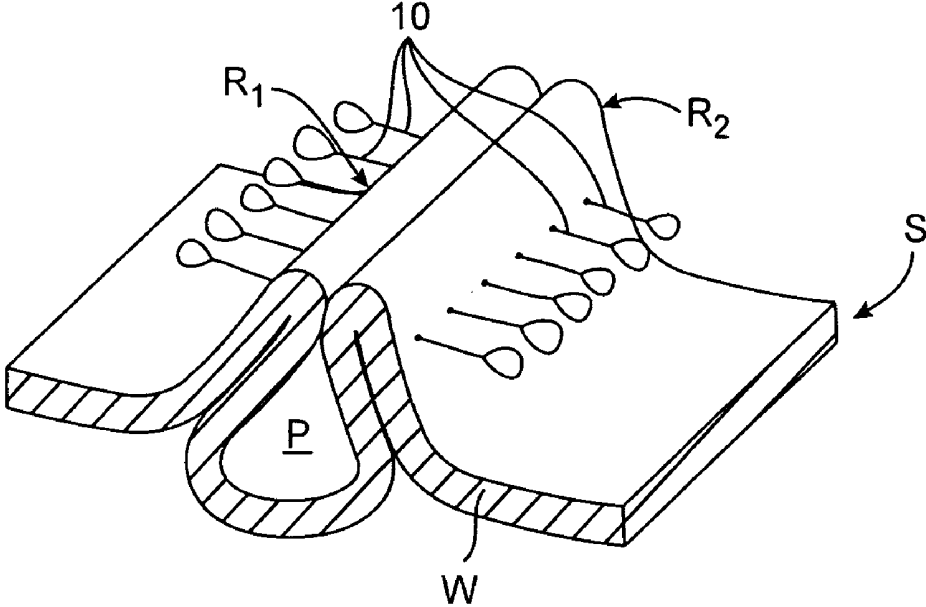

FIG. 9B

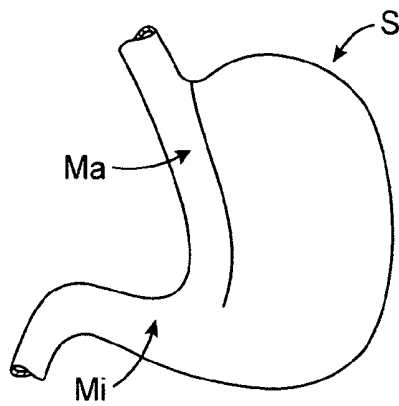

FIG. 10A

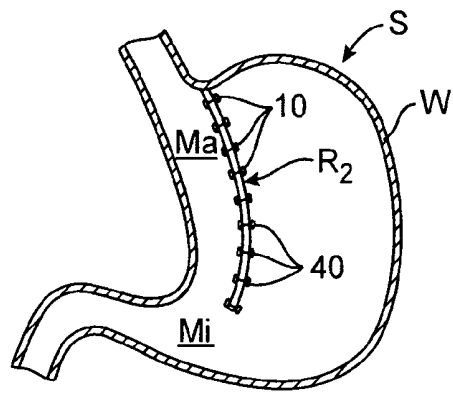

FIG. 10B

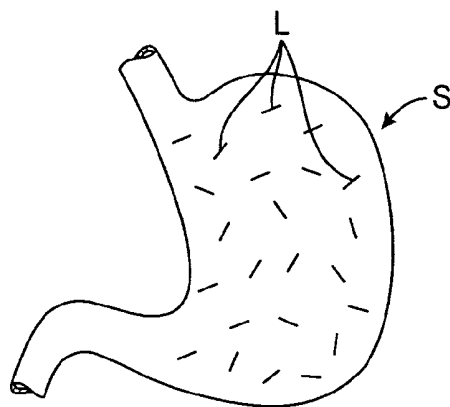

FIG. 11A

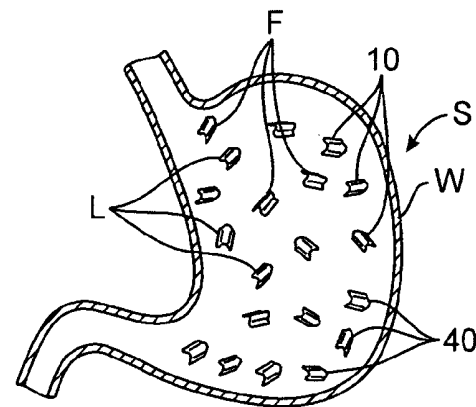

FIG. 11B

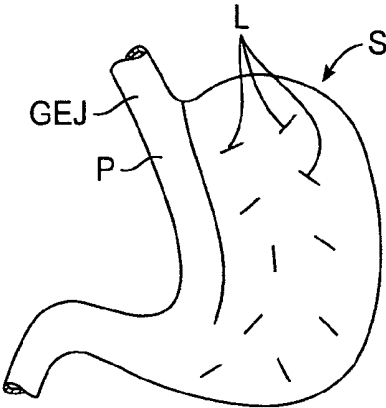

FIG. 12A

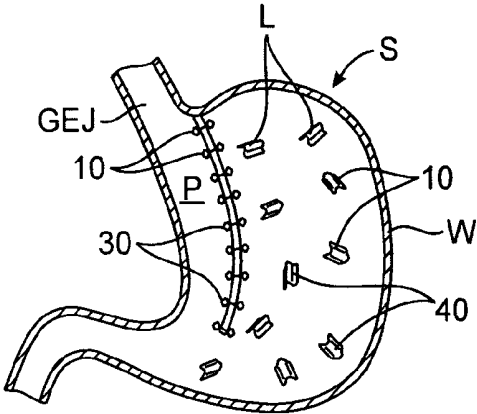

FIG. 12B

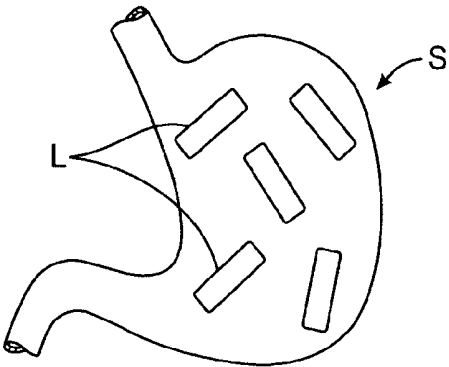

FIG. 13A

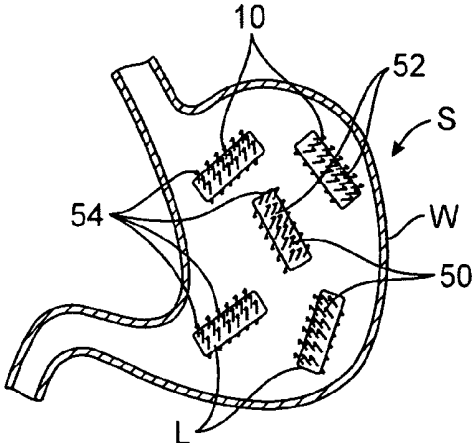

FIG. 13B

METHODS FOR PERFORMING GASTROPLASTY**CROSS-REFERENCES TO RELATED APPLICATIONS**

[0001] NOT APPLICABLE

STATEMENT AS TO RIGHTS TO INVENTIONS MADE UNDER FEDERALLY SPONSORED RESEARCH OR DEVELOPMENT

[0002] NOT APPLICABLE

REFERENCE TO A "SEQUENCE LISTING," A TABLE, OR A COMPUTER PROGRAM LISTING APPENDIX SUBMITTED ON A COMPACT DISK

[0003] NOT APPLICABLE

BACKGROUND OF THE INVENTION**Field of the Invention**

[0004] The present invention relates to methods for reducing the effective cross-sectional area of a gastro-intestinal ("GI") lumen.

[0005] Extreme or morbid obesity is a serious medical condition pervasive in the United States and other countries. Its complications include hypertension, diabetes, coronary artery disease, stroke, congestive heart failure, multiple orthopedic problems and pulmonary insufficiency with markedly decreased life expectancy.

[0006] Several surgical techniques have been developed to treat morbid obesity, including bypassing an absorptive surface of the small intestine, bypassing a portion of the stomach, and reducing the stomach size, e.g., via Vertical Banded Gastroplasty ("VBG") or Magenstrasse and Mill. These procedures may be difficult to perform in morbidly obese patients and/or may present numerous potentially life-threatening post-operative complications. Thus, less invasive techniques have been pursued.

[0007] U.S. Pat. Nos. 4,416,267 and 4,485,805 to Garren et al. and Foster, Jr., respectively, propose disposal of an inflated bag within a patient's stomach to decrease the effective volume of the stomach that is available to store food. Accordingly, the patient is satiated without having to consume a large amount of food. A common problem with these inflated bags is that, since the bags float freely within the patient's stomach, the bags may migrate to, and block, a patient's pyloric opening, the portal leading from the stomach to the duodenum, thereby restricting passage of food to the remainder of the gastro-intestinal tract.

[0008] Apparatus and methods also are known in which an adjustable elongated gastric band is disposed around the outside of a patient's stomach near the esophagus to form a collar that, when tightened, squeezes the stomach into an hourglass shape, thereby providing a stoma that limits the amount of food that a patient may consume comfortably. An example of an adjustable gastric band is the LAP-BAND® made by INAMED HEALTH of Santa Barbara, Calif.

[0009] Numerous disadvantages are associated with using the adjustable gastric band. First, the band may be dislodged if the patient grossly overeats, thereby requiring additional

invasive surgery to either reposition or remove the band. Similarly, overeating may cause the band to injure the stomach wall if the stomach over-expands. The laparoscopic disposal of the gastric band around the stomach requires a complex procedure, requires considerable skill on the part of the clinician, and is not free of dangerous complications.

[0010] In view of the drawbacks associated with prior art techniques for treating morbid obesity, it would be desirable to provide improved methods for performing gastroplasty.

SUMMARY OF THE INVENTION

[0011] Improved methods for performing gastroplasty are achieved by reducing the effective volume or cross-sectional area of the stomach via approximation of gastric tissue. Such reduction preferably is achieved endoluminally, either with or without laparoscopic ports. The methods generally comprise delivering securing elements, such as anchors and/or suture, on opposing sides of the gastric lumen, and then approximating the opposing walls of the lumen via the securing elements. Preferably, serosal-to-serosal folds of gastric tissue are formed on opposing sides of the gastric lumen, and are then approximated. A variety of methods for forming, securing and approximating the opposing serosal-to-serosal folds are described. In one variation, the opposing folds are individually formed and secured, and are then approximated and secured to one another. The individual folds may be reinforced after initial securing. In an alternative variation, the folds are not individually secured, but rather are only secured to one another after approximation. The approximated folds also may be reinforced after initial securing.

[0012] In addition to approximation of individual opposing folds of gastric tissue, opposing ridges of serosal-to-serosal folds may be formed and approximated. In this manner, a sleeve or an approximation of significant length may be formed. A variety of methods for forming, securing and approximating the opposing ridges are described.

[0013] In one variation, a sleeve, pouch, Magenstrasse, Vertical Banded Gastroplasty ("VBG"), etc. is formed within the stomach by approximating opposing anterior and posterior segments or ridges of the stomach wall at locations inferior to the gastroesophageal junction. In another variation, opposing walls of the stomach are approximated at a plurality of substantially random locations to reduce an effective volume of the stomach. In yet another variation, both a sleeve and random approximations are formed, the random approximations preferably disposed in the larger portion of the stomach excluded by the sleeve. In still another variation, opposing walls of the stomach are approximated over significant lengths at random or specified locations.

BRIEF DESCRIPTION OF THE DRAWINGS

[0014] **FIGS. 1A-1D** are schematic views of illustrative securing elements for use in performing gastroplasty;

[0015] **FIGS. 2A-2C** are schematic cross-sectional views illustrating a method of approximating opposing walls of a patient's gastric lumen;

[0016] **FIG. 3** is a schematic side-sectional view illustrating formation and securing of a serosal-to-serosal fold;

[0017] FIGS. 4A-4C are schematic cross-sectional views illustrating a method of forming, securing and approximating opposing serosal-to-serosal folds, as well as optionally reinforcing the individual folds;

[0018] FIG. 5 is a schematic cross-sectional view illustrating an alternative method of forming, securing and approximating opposing serosal-to-serosal folds;

[0019] FIGS. 6A and 6B are schematic cross-sectional views illustrating another alternative method of forming, securing and approximating the folds, as well as optionally reinforcing the approximated folds;

[0020] FIG. 7 is a schematic cross-sectional view illustrating yet another alternative method of forming, securing and approximating the folds;

[0021] FIG. 8 is a schematic cross-sectional view illustrating still another method of forming, securing and approximating the folds;

[0022] FIGS. 9A and 9B are schematic side-sectional views illustrating a method of forming, securing and approximating opposing ridges of serosal-to-serosal gastric tissue folds;

[0023] FIGS. 10A and 10B are side and side-sectional views illustrating a method of approximating anterior and posterior segments or ridges of a patient's stomach to form a sleeve, Magenstrasse and Mill, VBG pouch, etc.;

[0024] FIGS. 11A and 11B are side and side-sectional views illustrating a method of approximating opposing sides of the gastric lumen at substantially random locations;

[0025] FIGS. 12A and 12B are side and side-sectional views illustrating a method of forming both a sleeve and random approximations within the gastric lumen; and

[0026] FIGS. 13A and 13B are side and side-sectional views illustrating a method of approximating opposing walls of the stomach over significant lengths.

DETAILED DESCRIPTION OF THE INVENTION

[0027] Improved methods for reducing the effective volume or cross-sectional area of a gastro-intestinal ("GI") lumen via approximation of gastric tissue are described. The methods generally comprise delivering securing elements, such as anchors and/or suture, e.g. knotted suture, on opposing sides of the gastric lumen, and then approximating the opposing walls of the lumen via the securing elements. With reference to FIG. 1, exemplary securing elements for use in performing gastropasty are described. In FIG. 1A, securing element 10 comprises suture 20 having at least one knot 22. Knots 22 may be pre-tied, or may be tied by the medical practitioner as needed.

[0028] In FIG. 1B, securing element 10 comprises anchor assembly 30 having proximal basket 32 and distal basket 34 that are connected by suture 33. The length of suture disposed between the proximal and distal baskets may be fixed or adjustable. Additional exemplary anchor assemblies are described in Applicant's co-pending U.S. patent application Ser. No. 10/612,170, filed Jul. 1, 2003, which is incorporated herein by reference in its entirety.

[0029] In FIG. 1C, securing element 10 comprises bar- or t-anchor assembly 40. Assembly 40 comprises proximal t-anchor 42 and distal t-anchor 44 that are connected by suture 43. As with anchor assembly 30, the length of suture disposed between the proximal and distal t-anchors may be fixed or adjustable. Exemplary apparatus and methods for delivering, deploying and adjusting anchor assembly 40 are described in Applicant's co-pending U.S. patent application Ser. No. 10/735,030, filed Dec. 12, 2003, which is incorporated herein by reference in its entirety.

[0030] In FIG. 1D, securing element 10 comprises multi-barbed device 50. Device 50 comprises substrate 52 having a plurality of barbs 54 that project therefrom. Barbs 54 illustratively project from both sides of substrate 52 in FIG. 1D, but it should be understood that the barbs alternatively may project from only one side of the substrate. Barbs 54 optionally may comprise hooks and/or loops, and a plurality of complementary hook/loop multi-barbed devices 50 may be used in conjunction to adhere such complementary devices together. Additional exemplary multi-barbed devices are described in Applicant's co-pending U.S. patent application Ser. No. 09/746,579, filed Dec. 20, 2000, which is incorporated herein by reference in its entirety. Additional variations of securing element 10 will be apparent to those of skill in the art.

[0031] Referring now to FIG. 2, a method of approximating opposing walls of a patient's gastric lumen is described. In FIG. 2A, wall W of stomach S is secured at a first location with securing element 10a. In FIG. 2B, wall W is secured at an opposing second location with securing element 10b. Elements 10a and 10b are connected by suture 11. In FIG. 2C, the length of suture disposed between elements 10a and 10b is reduced, thereby approximating the opposing locations of the stomach wall.

[0032] Prior art gastropasty techniques typically achieve gastropasty by manipulating or operating on the exterior of a patient's stomach. However, in order to minimize invasiveness, it is desirable to endoluminally perform gastropasty, for example, via instruments inserted down a patient's throat or via instruments inserted laparoscopically and transgastrically within the gastric lumen. Although tissue approximation may be achieved endoluminally utilizing the method of FIG. 2, securing elements 10 extend from the interior of stomach S to the exterior of the stomach. This may be undesirable for some high-risk patients or procedures, as a possibility exists of puncturing or otherwise damaging surrounding anatomy when placing securing elements across gastric wall W to the exterior of the gastric lumen.

[0033] With reference to FIG. 3, a method for endoluminally securing the wall at specified locations without exiting the gastric lumen is described. Gastric wall W of stomach S comprises multiple tissue layers, including mucosa M, muscularis Mu and serosa S. In FIG. 3, wall W has been plicated to form serosal-to-serosal tissue fold F. Exemplary methods and apparatus for plicating tissue wall W to form fold F are described, for example, in Applicant's co-pending U.S. patent application Ser. No. 10/735,030, filed Dec. 12, 2003, which previously has been incorporated herein by reference in its entirety. Tissue fold F has been secured with securing element 10 illustratively having a first portion disposed on a first side of fold F, a suture that extends through the fold, and

a second portion disposed on the opposite side of fold F. The length of suture disposed between the first and second portions of securing element **10** preferably is adjustable to provide specified tensioning across fold F.

[0034] Referring now to **FIG. 4**, a method of forming, securing and approximating opposing serosal-to-serosal folds is described. In **FIG. 4A**, a first serosal-to-serosal fold F_1 is formed and is secured at a first location within stomach S via first securing element **10a**. Likewise, a second serosal-to-serosal fold F_2 is formed and secured at a second opposing location within stomach S via second securing element **10b**. A first portion of securing element **10c** then is passed through first fold F_1 , while a second portion of the securing element is passed through second fold F_2 , as in **FIG. 4B**. In **FIG. 4C**, the length of suture disposed between the first and second portions of securing element **10c** is reduced, thereby approximating opposing tissue folds F_1 and F_2 . As will be apparent to those of skill in the art, such approximation may be used to achieve endoluminal gastroplasty.

[0035] The serosal-to-serosal tissue folds optionally may be reinforced to enhance long-term durability. In **FIG. 4D**, an additional securing element has been placed through each serosal-to-serosal fold. Securing element **10d** has been placed through fold F_1 , while securing element **10e** has been placed through fold F_2 . Although folds F_1 and F_2 illustratively have been reinforced after they have been approximated, it will be apparent to those of skill in the art that the folds alternatively may be reinforced prior to, or during, approximation.

[0036] With reference to **FIG. 5**, an alternative method of forming, securing and approximating opposing serosal-to-serosal folds is described. In **FIG. 5**, first securing element **10a**, which secures tissue fold F_1 , and second securing element **10b**, which secures tissue fold F_2 , are connected to one another by suture **11**. Tissue folds F_1 and F_2 are approximated by reducing the length of suture **11** disposed between securing elements **10a** and **10b** (in **FIG. 5**, the folds illustratively are shown in a partially approximated configuration).

[0037] Referring now to **FIG. 6**, another alternative method of forming, securing and approximating opposing tissue folds is described. In **FIG. 6A**, a single securing element **10** is used to form and secure both first tissue fold F_1 and second tissue fold F_2 , as well as to approximate the two tissue folds. Securing element **10** preferably also is configured to maintain such approximation of the tissue folds.

[0038] Securing element **10** illustratively comprises first and second suture loops **12a** and **12b** that may be grasped to adjust the length of suture disposed between the first and second tissue folds to approximate the folds. For example, one or both of suture loops **12a** and **12b** may be pulled away from the tissue folds while one or both of anchoring elements **13a** and **13b** of securing element **10** are held stationary or advanced toward the folds. Alternatively, the suture loop(s) may be held stationary while the anchoring element(s) are advanced. The anchoring elements preferably comprise a ratcheting mechanism that adjusts, e.g. reduces, and maintains the length of suture **11** disposed between the anchoring elements (thereby approximating the tissue folds) upon such force application. Illustrative ratcheting mechanisms for securing element **10** are described, for example, in

Applicant's co-pending U.S. patent application Ser. No. 10/735,030, filed Dec. 12, 2003, which previously has been incorporated herein by reference.

[0039] As seen in **FIG. 6B**, the approximated serosal-to-serosal tissue folds may be reinforced to ensure that the folds remain closely approximated. In **FIG. 6B**, securing element **10'** has been placed across folds F_1 and F_2 after the folds have been approximated. Element **10'** alternatively may be placed prior to approximation, e.g., to better distribute forces during approximation.

[0040] With reference to **FIG. 7**, yet another alternative method for approximating tissue folds is described. As with the method of **FIG. 6A**, in **FIG. 7** the tissue folds are formed and approximated with a single securing element **10**. However, the securing element only comprises a single suture loop **12** (illustratively in combination with optional cinching or crimping element **14**), which is disposed between tissue folds F_1 and F_2 . In this manner, ratcheting of securing element **10** to approximate folds F_1 and F_2 may be achieved by grasping suture loop **12** between the folds.

[0041] **FIG. 8** illustrates still another alternative method. Tissue folds F_1 and F_2 are formed and secured with first and second securing elements **10a** and **10b**, illustratively comprising previously described t-anchor assemblies **40a** and **40b**. The folds are approximated via securing element **10c**, which illustratively comprises previously described anchor assembly **30**. As in **FIG. 7**, securing element **10c** comprises only a single suture loop **12**; however, the loop illustratively is disposed on the outer side of tissue fold F_2 , as opposed to between tissue folds F_1 and F_2 .

[0042] Referring now to **FIG. 9**, in addition to forming, securing and approximating opposing serosal-to-serosal gastric tissue folds, opposing ridges of such folds may be formed, secured, approximated, etc. In **FIG. 9**, first ridge R_1 and opposing second ridge R_2 of serosal-to-serosal tissue fold are formed, secured and approximated, illustratively utilizing a variation of the method described hereinabove with respect to **FIG. 6**. As will be apparent to those of skill in the art, although ridges R_1 and R_2 illustratively are formed and approximated utilizing a method adapted from that described with respect to **FIG. 6**, any alternative method, including any adaptation of the methods described with respect to **FIGS. 4, 5, 7** and/or **8**, may additionally or alternatively be utilized.

[0043] As seen in **FIG. 9A**, a plurality of securing elements **10** have been placed across ridges R_1 and R_2 , with sutures **11** extending between the ridges. In **FIG. 9B**, the length of sutures **11** between the ridges has been reduced in order to approximate the ridges, thereby forming an approximation of significant length and/or a sleeve or pouch P within stomach S. Pouch P optionally may be reinforced, e.g. via additional securing elements or via suture wrapped in a circular manner about the apexes of approximated ridges R_1 and R_2 . Additionally or alternatively, a stabilizing agent, e.g. fibrin, may be injected into the ridges to secure and/or reinforce the ridges, for example, by coagulating blood within the ridges.

[0044] Referring now to **FIG. 10** in conjunction with **FIG. 9**, when sleeve or pouch P is formed within a patient's stomach from opposing anterior and posterior segments or ridges of the stomach wall W at locations just inferior to the

patient's gastroesophageal junction GEJ, the pouch forms an endoluminal VBG or Magenstrasse and Mill (dependent upon the profile, diameter, length, etc., of the pouch). In **FIG. 10A**, an external side view of stomach S illustrates formation of a Magenstrasse Ma and Mill Mi gastroplasty within the stomach. **FIG. 10B** illustrates the same via a side-sectional view showing posterior ridge R₂ formed with securing elements **10**, illustratively t-anchor assemblies **40** of **FIG. 1C**.

[0045] As will appear to those of skill in the art, endoluminal pouch or Magenstrasse gastroplasty optionally may be achieved without forming tissue fold ridges R₁ and R₂. For example, the opposing walls of stomach S may be approximated to form Magenstrasse Ma in a manner similar to that described hereinabove with respect to **FIG. 2**, i.e. via securing elements that exit the gastric lumen. Formation of Magenstrasse Ma reduces the effective volume and/or cross-sectional area of stomach S by excluding the fundus and a portion of the body of the stomach from food, while still allowing fluid to flow from the excluded region to antrum Mi.

[0046] Referring now to **FIG. 11**, an alternative method for performing gastroplasty is described. As seen in **FIG. 11A**, opposing sides of stomach S may be approximated and secured at substantially random locations L. It is expected that such random approximations will reduce the effective volume and/or cross-sectional area of the stomach and produce a sensation of satiety by increasing the resident time of food within the stomach. Furthermore, it is expected that the approximations will reduce a quantity of food that a patient may comfortably consume at one sitting and/or may reduce peristalsis of the stomach.

[0047] The side-sectional view of **FIG. 11B** shows illustrative posterior folds F formed with securing elements **10** illustratively comprising t-anchor assemblies **40** of **FIG. 1C**. Such folds may be approximated with complementary opposing anterior folds to form the approximations of **FIG. 11A** at substantially random locations L. In order to achieve a desired degree of weight loss, a medical practitioner may specify the aggressiveness (i.e. the volume and/or density) of random approximation formation. Furthermore, as an alternative to random location selection, approximations may be made at specified locations within stomach S to provide the patient's gastric lumen with any specified/desired geometry.

[0048] With reference to **FIG. 12**, a method of forming both a sleeve and random approximations within the gastric lumen is described. Formation of pouch P has been described previously hereinabove with respect to **FIGS. 9 and 10**, while formation of approximations at random locations L has been described with respect to **FIG. 11**. As seen in **FIG. 12A**, sleeve or pouch P may extend inferior to the patient's gastroesophageal junction GEJ, while approximations are disposed at substantially random locations L within stomach S. As seen in **FIG. 12B**, pouch P illustratively has been formed with securing elements **10** comprising anchor assemblies **30** of **FIG. 1B**, while the random approximations illustratively have been formed with securing elements comprising t-anchor assemblies **40** of **FIG. 1C**.

[0049] Pouch P and the approximations at random locations L may be formed concurrently or successively in any order. Random locations L preferably are confined to the

region of stomach S disposed outside of sleeve or pouch P to ensure safe passage of food through the pouch. Providing pouch P in conjunction with approximations at random locations L may more fully restrict the stomach, thereby enhancing a sensation of satiety, prolonging the resident time of food within the stomach, and/or reducing a quantity of food that may be comfortably consumed.

[0050] Referring now to **FIG. 13**, a method of approximating opposing walls of the stomach over significant length(s) at random or specified locations is described. As seen in **FIG. 13A**, stomach S illustratively has been approximated at multiple random or specified locations L over significant lengths, for example, lengths preferably greater than or equal to about 1 cm, and even more preferably greater than or equal to about 2 cm. As seen in **FIG. 13B**, such approximations have been achieved by utilizing securing elements **10** comprising multi-barbed devices **50** of **FIG. 1D**. For example, barbs **54** extending from first surfaces of substrates **52** of devices **50** may be adhered to a first wall of stomach S, while barbs **54** extending from opposing second surfaces of the substrates may be adhered to opposing walls of the stomach, thereby approximating and securing the opposing walls. The lengths of devices **50** may be specified as desired. Additional and/or alternative methods for approximating opposing walls of the stomach over significant lengths will be apparent to those of skill in the art.

[0051] Although various illustrative embodiments are described above, it will be evident to one skilled in the art that various changes and modifications are within the scope of the invention. It is intended in the appended claims to cover all such changes and modifications that fall within the true spirit and scope of the invention.

What is claimed is:

1. A method for performing gastroplasty, the method comprising:

endoluminally approximating opposing walls of a patient's stomach;

securing the approximated opposing walls; and

reinforcing the approximated and secured walls.

2. The method of claim 1, wherein endoluminally approximating opposing walls further comprises approximating the walls with instruments advanced down the patient's throat.

3. The method of claim 1, wherein endoluminally approximating opposing walls further comprises approximating the walls with instruments advanced laparoscopically and transgastrically within the patient's stomach.

4. The method of claim 1, wherein endoluminally approximating opposing walls further comprises:

forming tissue folds on the opposing walls; and

approximating the tissue folds.

5. The method of claim 4, wherein forming tissue folds further comprises forming serosal-to-serosal tissue folds.

6. The method of claim 4, wherein forming tissue folds further comprises forming tissue ridges.

7. The method of claim 6, wherein approximating the tissue folds further comprises approximating the tissue ridges.

8. The method of claim 7, wherein approximating the tissue ridges further comprises forming a sleeve or pouch within the patient's stomach.

9. The method of claim 8, wherein forming a sleeve or pouch further comprises forming a sleeve or pouch inferior to the patient's gastroesophageal junction.

10. The method of claim 9, wherein forming a sleeve or pouch inferior to the patient's gastroesophageal junction further comprises endoluminally achieving Vertical Banded Gastroplasty or Magenstrasse and Mill.

11. The method of claim 4 further comprising securing the tissue folds.

12. The method of claim 11 further comprising reinforcing the tissue folds.

13. The method of claim 1, wherein endoluminally approximating opposing walls further comprises endoluminally approximating the opposing walls at substantially random locations.

14. The method of claim 13 further comprising forming a sleeve or pouch within the patient's stomach, the randomly located approximations confined to regions of the stomach disposed outside of the sleeve or pouch.

15. The method of claim 1, wherein endoluminally approximating opposing walls further comprises forming a sleeve or pouch within the patient's stomach.

16. The method of claim 15, wherein forming a sleeve or pouch further comprises endoluminally achieving Vertical Banded Gastroplasty or Magenstrasse and Mill.

17. The method of claim 1, wherein endoluminally approximating opposing walls further comprises approximating the walls over a significant length greater than or equal to about 1 cm.

18. The method of claim 1, wherein securing the approximated opposing walls comprises securing the walls with at least one securing element, and

wherein approximating the walls further comprises approximating the walls via a ratcheting or tensioning mechanism of the securing element.

19. A method for performing gastroplasty, the method comprising:

endoluminally approximating opposing walls of a patient's stomach with instruments advanced laparoscopically and transgastrically within the patient's stomach; and

securing the approximated opposing walls.

20. A method for performing gastroplasty, the method comprising:

laparoscopically and transgastrically advancing instruments within a patient's stomach; and

endoluminally forming a pouch or sleeve within the stomach by approximating opposing walls of the stomach with the instruments.

* * * * *

专利名称(译)	进行胃成形术的方法		
公开(公告)号	US20050250980A1	公开(公告)日	2005-11-10
申请号	US10/841233	申请日	2004-05-07
[标]申请(专利权)人(译)	USGI医药股份有限公司		
申请(专利权)人(译)	USGI MEDICAL CORP.		
当前申请(专利权)人(译)	USGI MEDICAL INC.		
[标]发明人	SWANSTROM LEE L EWERS RICHARD C MAAHS TRACY D CHEN EUGENE G SAADAT VAHID		
发明人	SWANSTROM, LEE L. EWERS, RICHARD C. MAAHS, TRACY D. CHEN, EUGENE G. SAADAT, VAHID		
IPC分类号	A61B17/00 A61B17/04 A61B17/08 A61B17/11 A61F2/04 A61F5/00		
CPC分类号	A61B17/00234 A61B17/0401 A61B17/085 A61F5/0086 A61B2017/0496 A61B2017/081 A61B17/1114		
其他公开文献	US7520884		
外部链接	Espacenet USPTO		

摘要(译)

本发明提供了通过近似胃组织减少胃的有效体积或横截面积来进行胃成形术的方法。这种减少优选地通过腔内实现，具有或不具有腹腔镜端口。在一个变型中，通过在胃食管连接处以下的位置处近似胃壁的相对的前段和后段或脊，在胃内形成套管，小袋，Magenstrasse和Mill，Vertical Banded Gastroplasty (“VBG”) 等。。在另一个变型中，胃的相对壁在多个基本上随机的位置处近似，以减小胃的有效体积。在又一个变型中，形成套管和随机近似，随机近似优选地设置在由套管排除的胃的一部分中。在另一个变型中，胃的相对壁在随机或指定位置处在显著长度上近似。

