



US008777965B2

(12) **United States Patent**  
**Chen et al.**

(10) **Patent No.:** **US 8,777,965 B2**  
(45) **Date of Patent:** **Jul. 15, 2014**

(54) **DEVICES AND METHODS FOR  
LAPAROSCOPIC HERNIA REPAIR**

(56) **References Cited**

(75) Inventors: **Eugene G. Chen**, Carlsbad, CA (US);  
**Tracy D. Maahs**, Yorba Linda, CA (US);  
**Richard C. Ewers**, Fullerton, CA (US);  
**Lee L. Swanson**, Portland, OR (US)

(73) Assignee: **USGI Medical, Inc.**, San Clemente, CA (US)

(\*) Notice: Subject to any disclaimer, the term of this patent is extended or adjusted under 35 U.S.C. 154(b) by 283 days.

(21) Appl. No.: **13/103,936**

(22) Filed: **May 9, 2011**

(65) **Prior Publication Data**

US 2012/0265218 A1 Oct. 18, 2012

**Related U.S. Application Data**

(60) Provisional application No. 61/476,129, filed on Apr. 15, 2011.

(51) **Int. Cl.**  
**A61B 17/04** (2006.01)  
**A61B 17/00** (2006.01)

(52) **U.S. Cl.**  
CPC ..... **A61B 17/0401** (2013.01); **A61B 17/0487** (2013.01); **A61B 17/0057** (2013.01); **A61B 2017/0462** (2013.01); **A61B 17/0469** (2013.01); **A61B 2017/00575** (2013.01); **A61B 2017/00637** (2013.01)  
USPC ..... **606/139**; **606/151**; **606/232**

(58) **Field of Classification Search**  
USPC ..... **606/139**, **142**, **143**, **151**, **213-215**  
See application file for complete search history.

**U.S. PATENT DOCUMENTS**

4,006,747	A *	2/1977	Kronenthal et al.	606/144
4,235,238	A *	11/1980	Ogiu et al.	606/145
5,041,129	A *	8/1991	Hayhurst et al.	606/232
5,254,126	A *	10/1993	Filipi et al.	606/146
5,269,809	A *	12/1993	Hayhurst et al.	606/232
5,464,426	A *	11/1995	Bonutti	606/232
5,507,755	A *	4/1996	Gresl et al.	606/139
5,618,290	A *	4/1997	Toy et al.	606/139
6,113,611	A *	9/2000	Allen et al.	606/151
6,152,935	A *	11/2000	Kammerer et al.	606/144
7,186,262	B2	3/2007	Saadat	
7,347,863	B2 *	3/2008	Rothe et al.	606/139
7,601,159	B2 *	10/2009	Ewers et al.	606/139
7,618,426	B2	11/2009	Ewers et al.	
7,621,925	B2	11/2009	Saadat et al.	
7,736,374	B2	6/2010	Vaughan et al.	
7,736,378	B2	6/2010	Maahs et al.	
7,736,379	B2	6/2010	Ewers et al.	
7,846,180	B2 *	12/2010	Cerier	606/232
7,909,851	B2 *	3/2011	Stone et al.	606/232
7,942,898	B2	5/2011	Ewers et al.	
8,034,076	B2 *	10/2011	Criscuolo et al.	606/219
8,057,490	B2 *	11/2011	Harris et al.	606/139

(Continued)

*Primary Examiner* — Melanie Tyson

*Assistant Examiner* — Todd J Scherbel

(74) *Attorney, Agent, or Firm* — Kenneth H. Ohriner; Perkins Coie LLP

(57) **ABSTRACT**

Devices and methods for laparoscopically repairing a hernia are described. In some embodiments, a laparoscopic instrument is used to deploy one or more tissue anchor assemblies into the edges of the fascia tissue surrounding or adjacent to the hernia defect. The tissue anchor assemblies are used to cause the fascia tissue to be approximated to facilitate the repair procedure, to improve healing, and to reduce the incidence of recurrence.

**11 Claims, 25 Drawing Sheets**

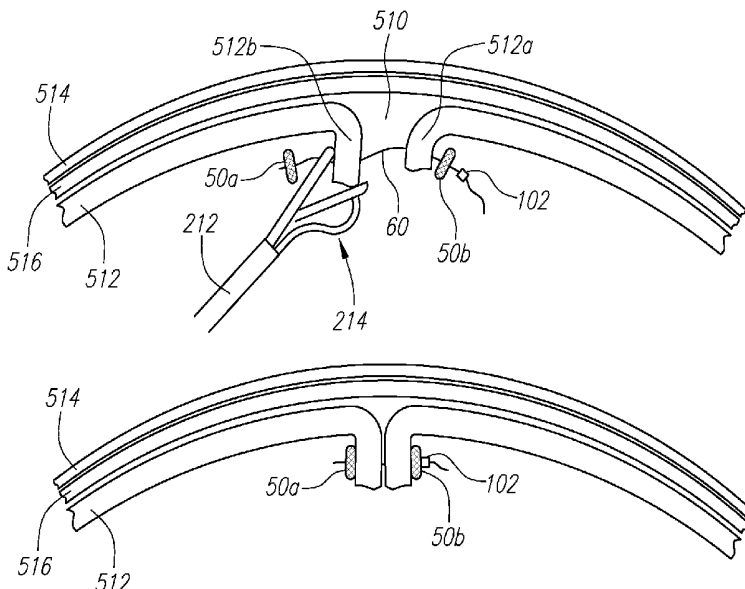

(56)

**References Cited**

U.S. PATENT DOCUMENTS

8,257,394	B2 *	9/2012	Saadat et al. ....	606/232	2005/0251157	A1	11/2005	Saadat et al.	
8,343,231	B1 *	1/2013	Christoudias .....	623/23.72	2005/0251207	A1	11/2005	Flores et al.	
8,357,172	B2 *	1/2013	Harper .....	606/151	2006/0235446	A1 *	10/2006	Godin .....	606/151
2003/0171761	A1 *	9/2003	Sancoff et al. ....	606/139	2007/0027358	A1 *	2/2007	Gertner et al. ....	600/37
2004/0092969	A1 *	5/2004	Kumar .....	606/151	2007/0112338	A1 *	5/2007	Cohen et al. ....	606/1
2004/0122456	A1	6/2004	Saadat et al. ....	606/151	2008/0009888	A1	1/2008	Ewers et al.	
2005/0216040	A1 *	9/2005	Gertner et al. ....	606/151	2008/0132948	A1 *	6/2008	Surti et al. ....	606/232
2005/0216042	A1 *	9/2005	Gertner .....	606/151	2008/0319455	A1 *	12/2008	Harris et al. ....	606/139
					2009/0018576	A1 *	1/2009	Binmoeller .....	606/215
					2009/0312603	A1	12/2009	Lam et al.	
					2011/0208209	A1 *	8/2011	Ewers et al. ....	606/139

\* cited by examiner

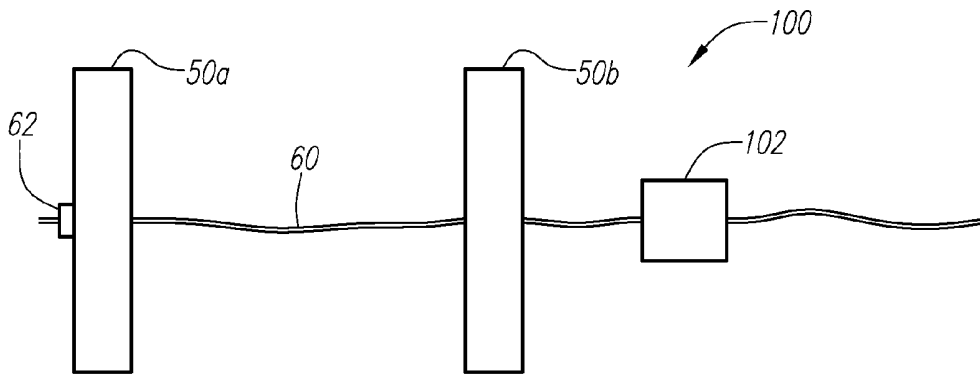

FIG. 1

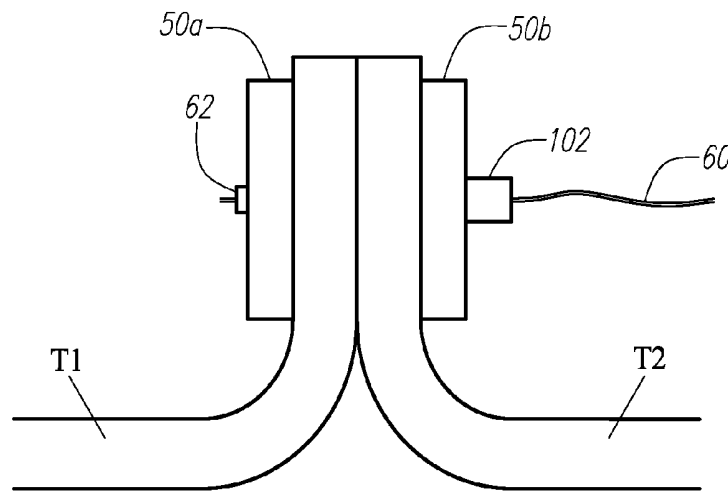

FIG. 2A

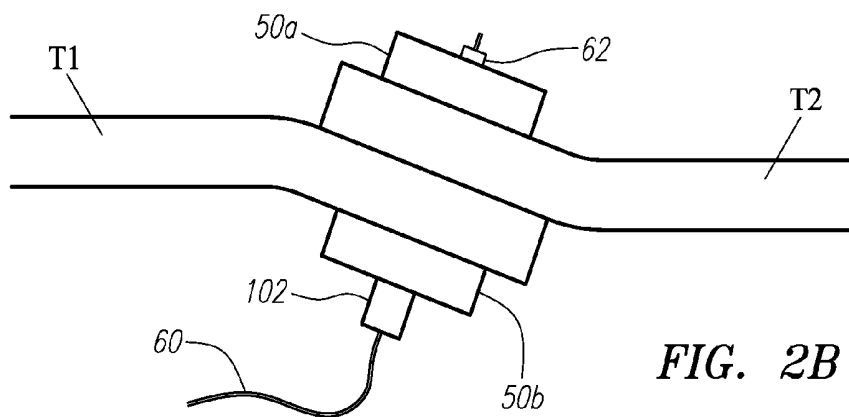

FIG. 2B

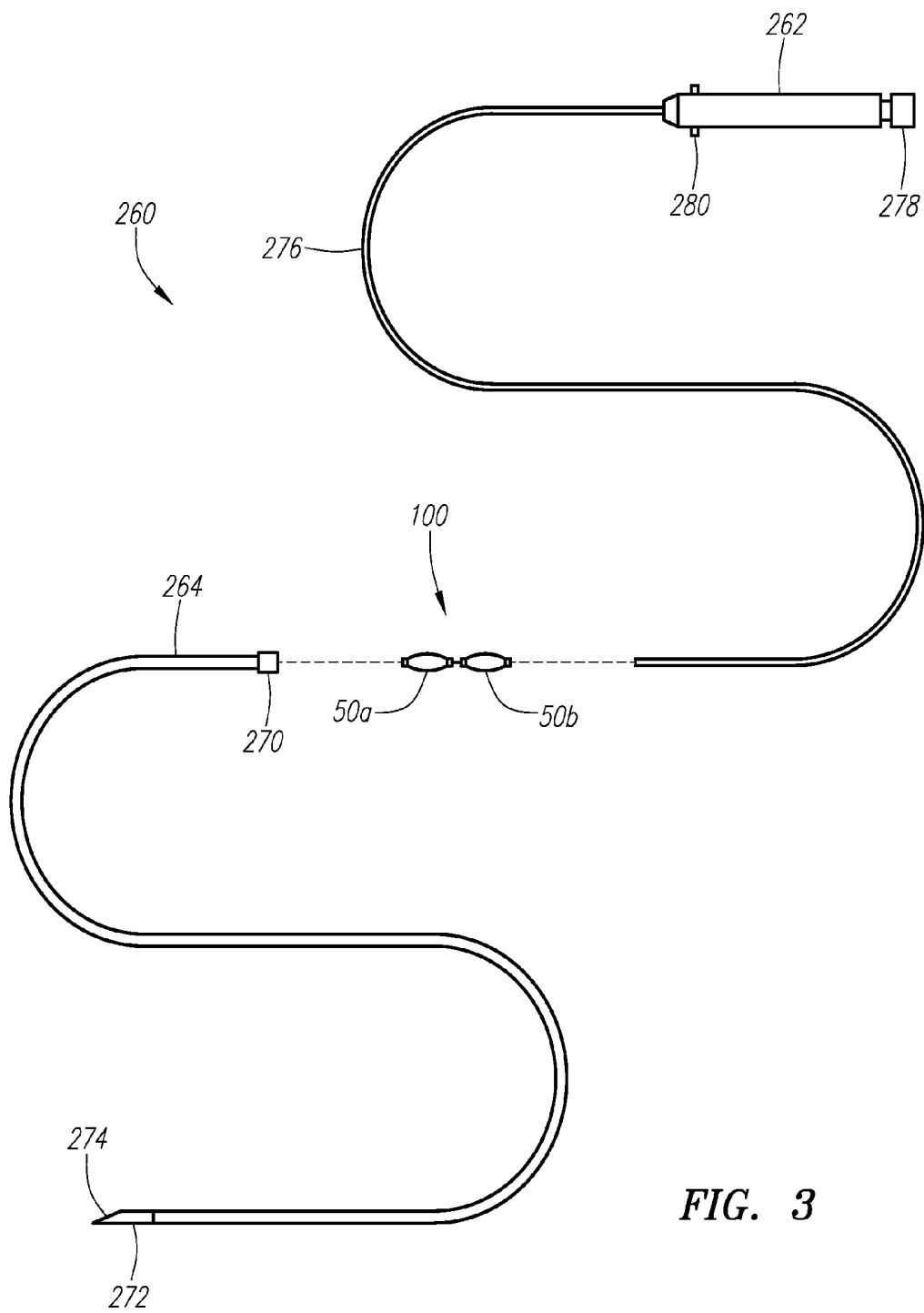

FIG. 3

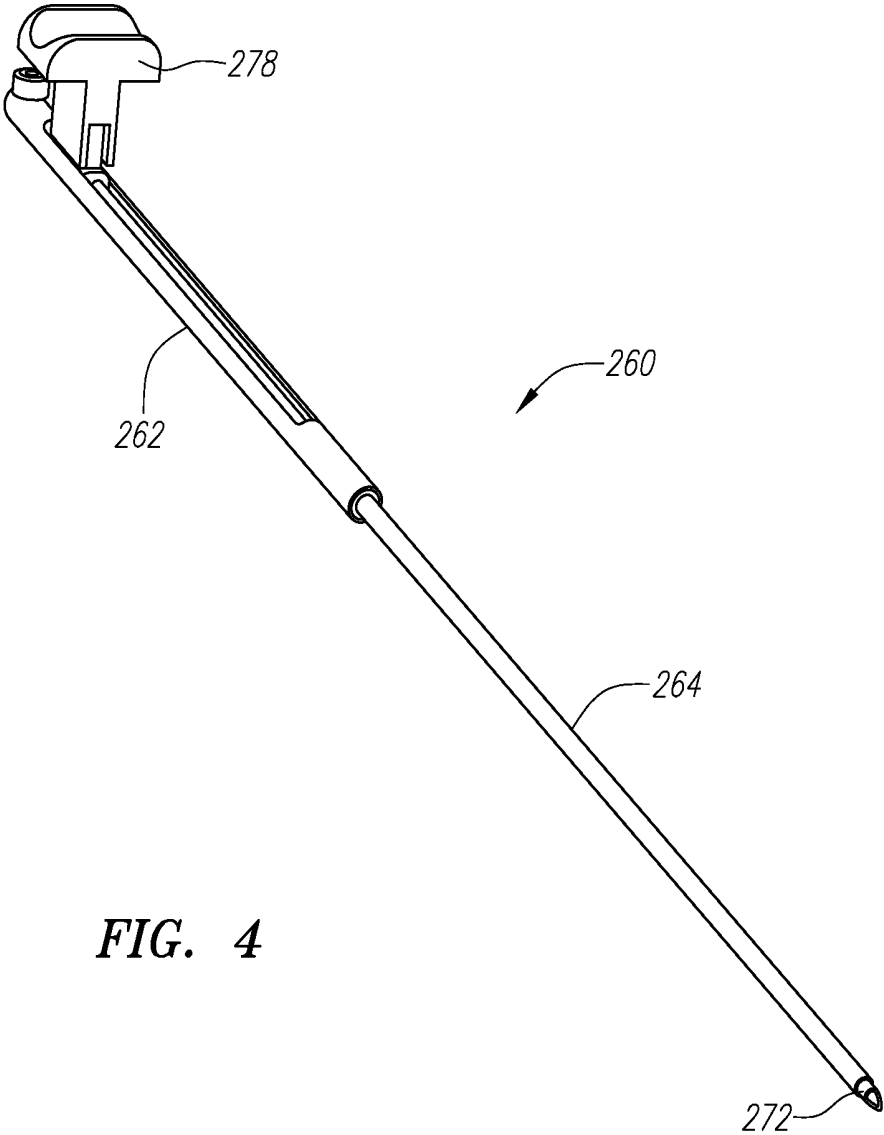
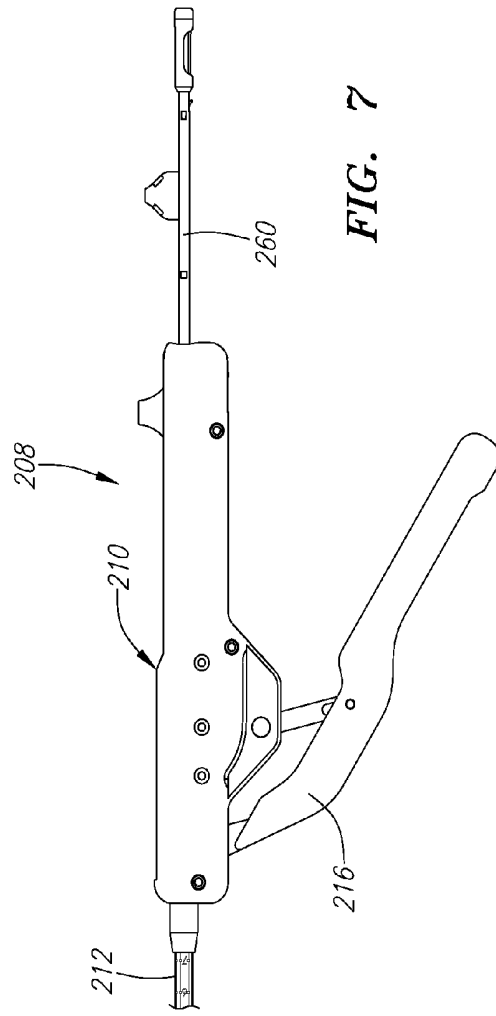
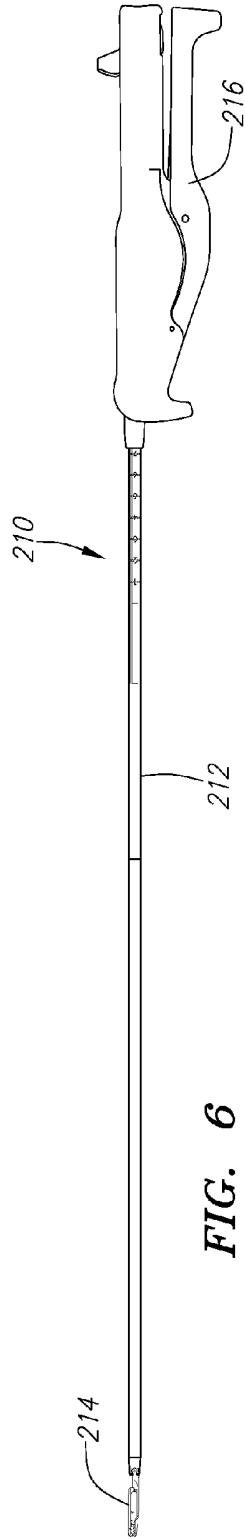
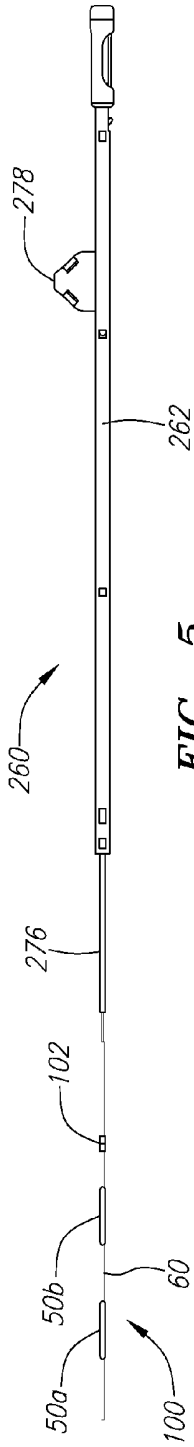

FIG. 4



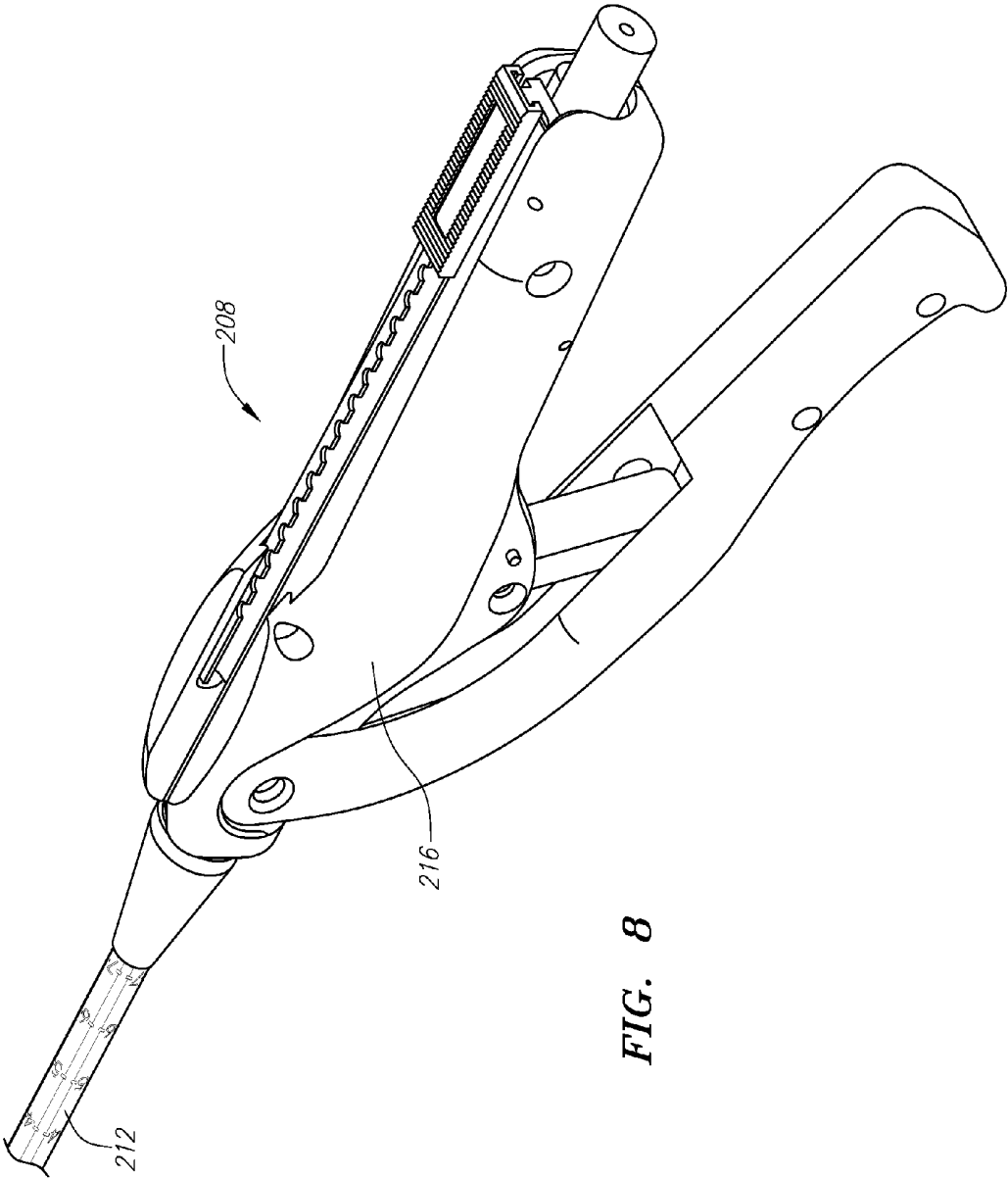

FIG. 8

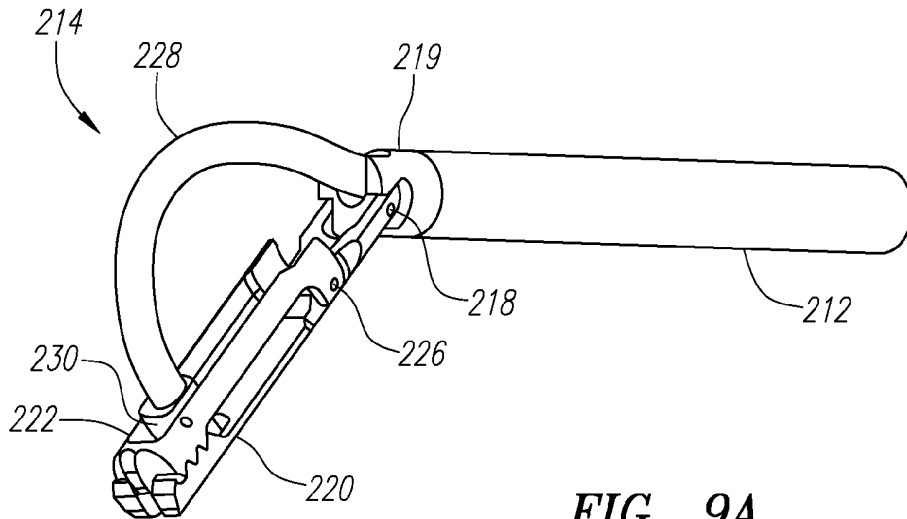

FIG. 9A

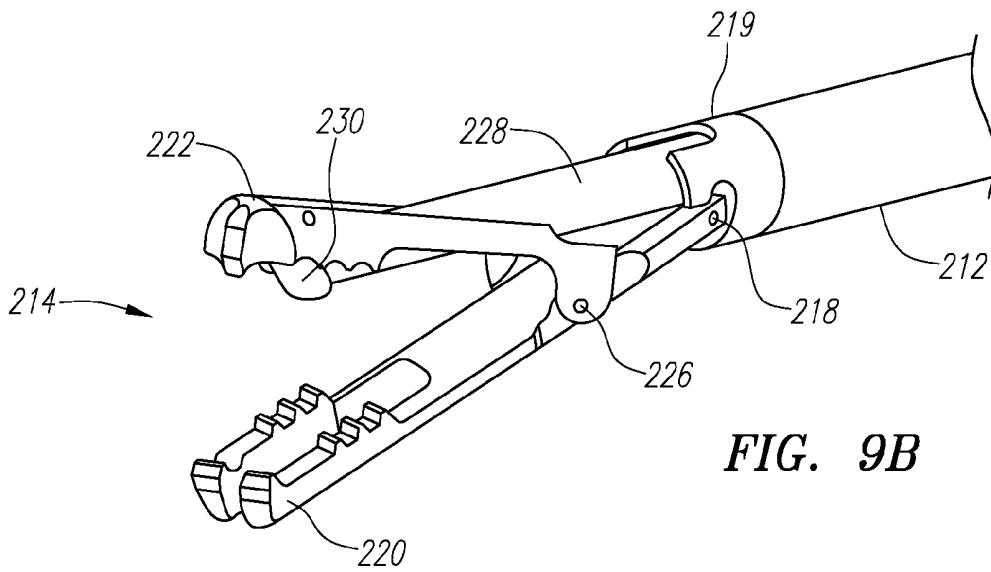

FIG. 9B

FIG. 9C

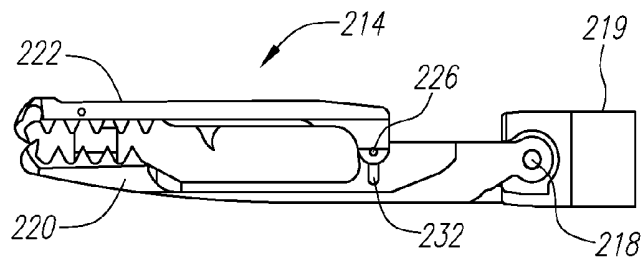

FIG. 9D

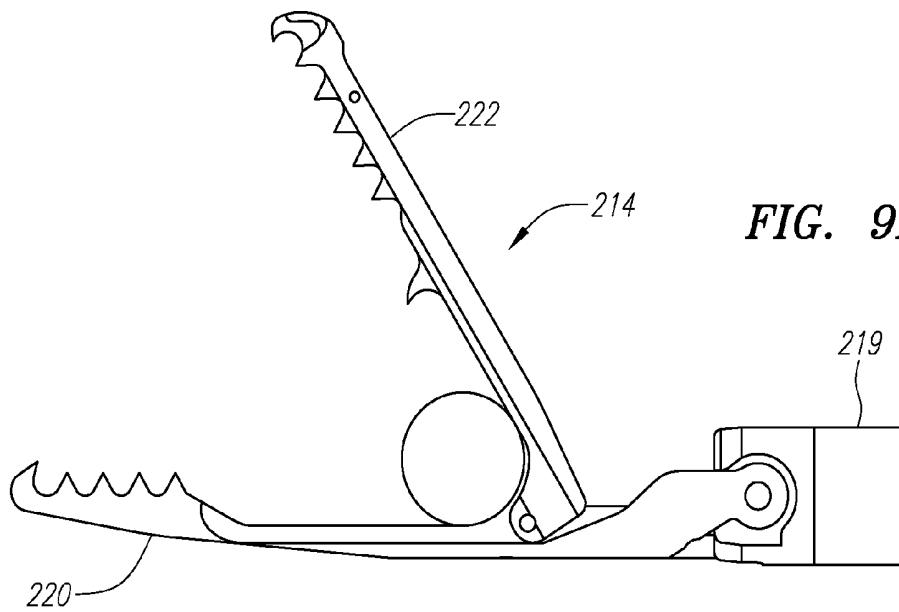
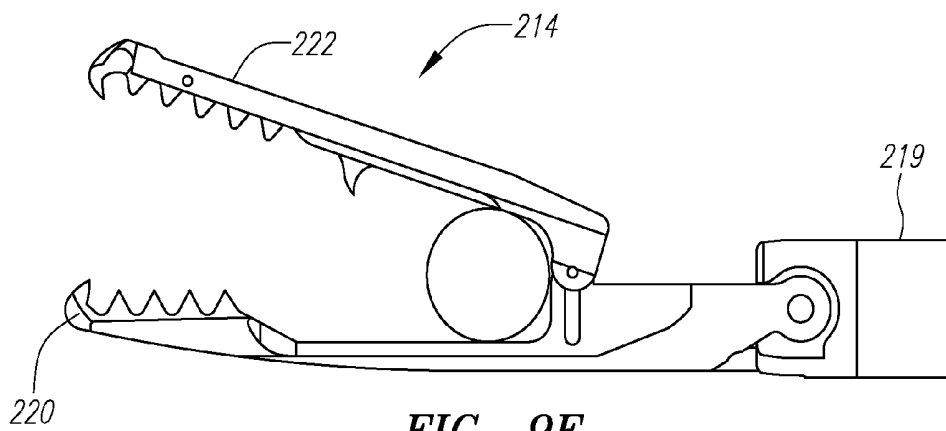

FIG. 9E



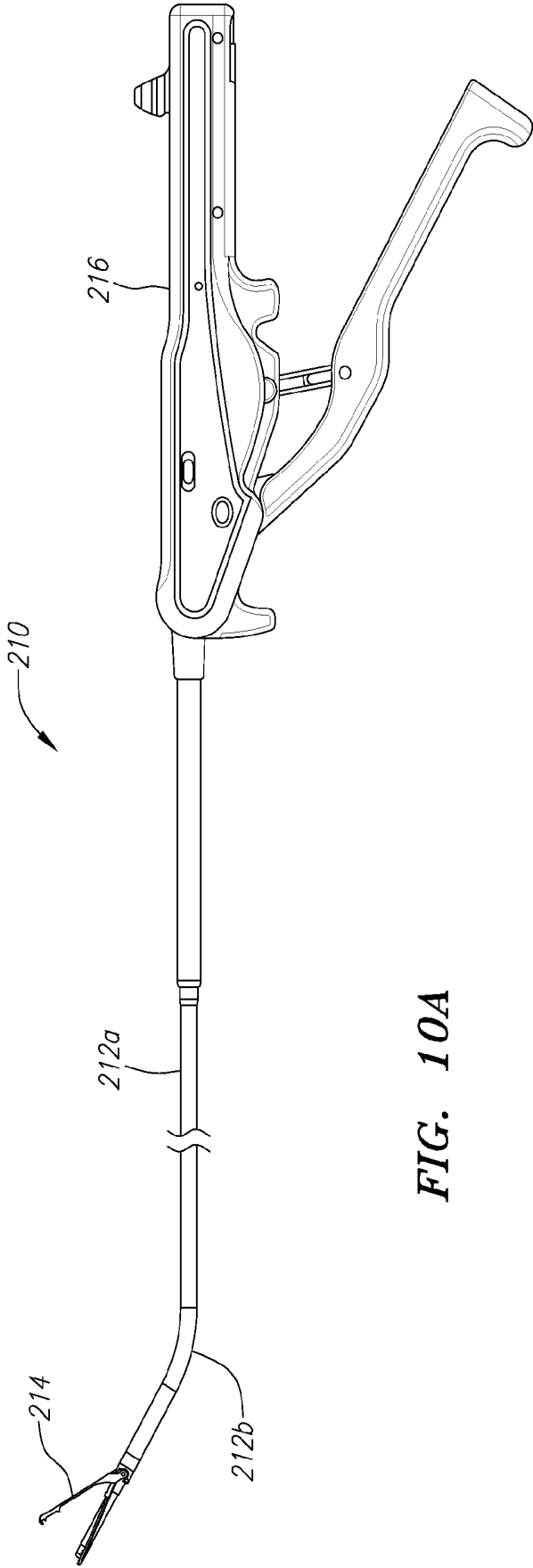

FIG. 10A

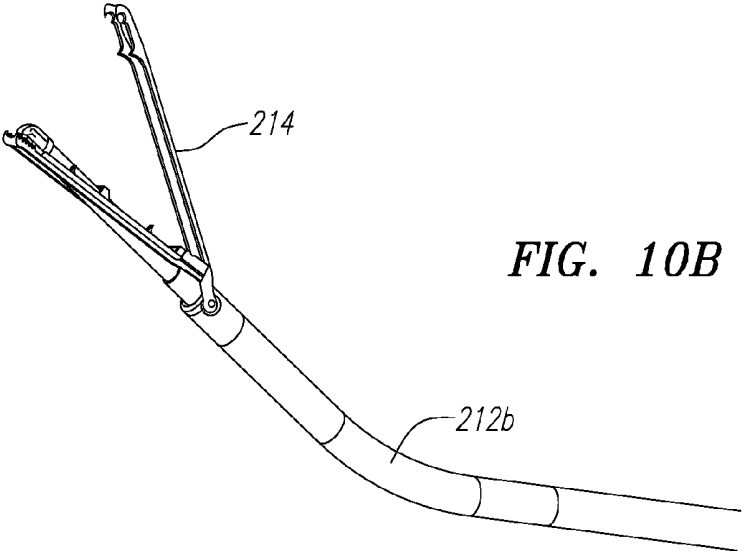

FIG. 10B

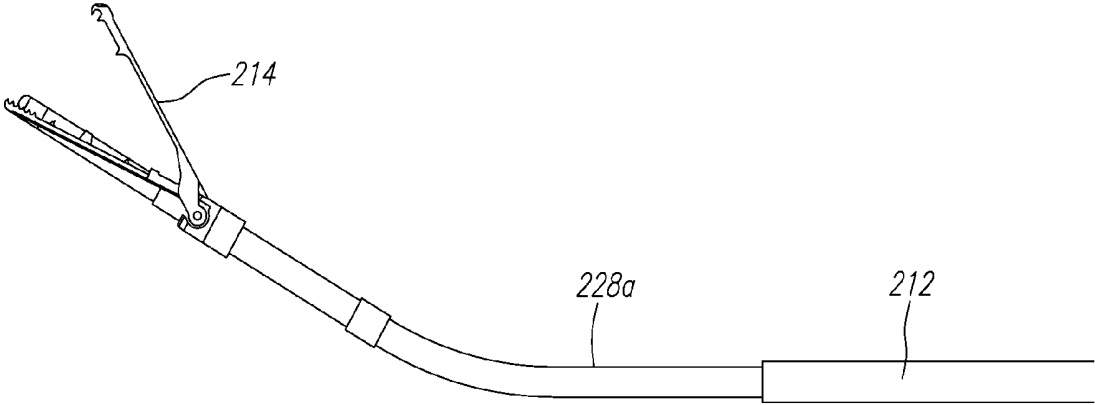
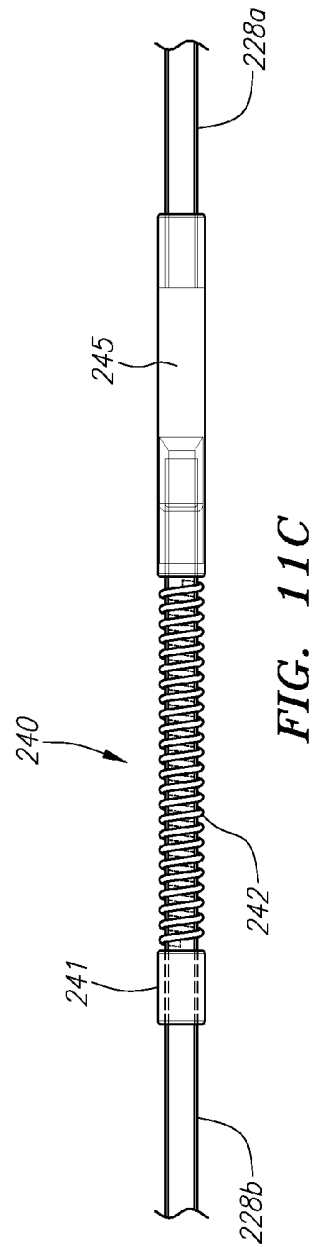
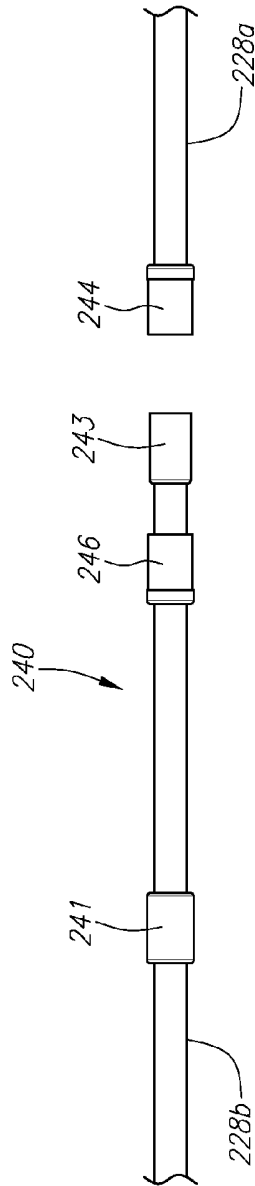
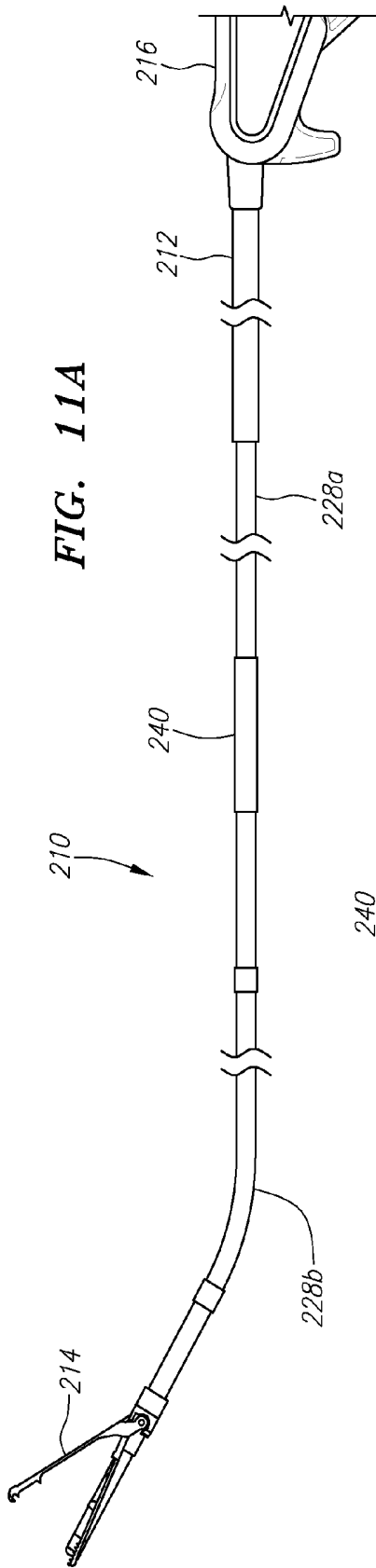

FIG. 10C



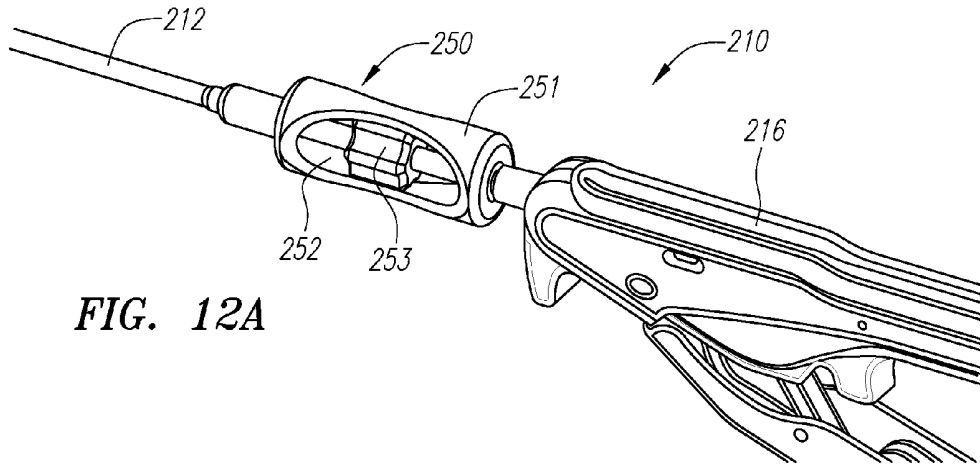

FIG. 12A

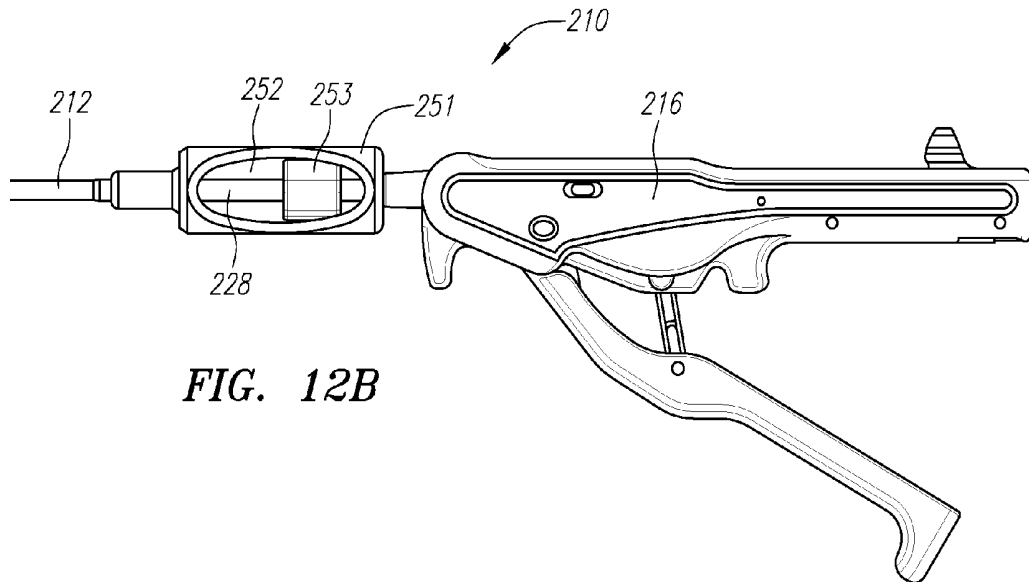

FIG. 12B

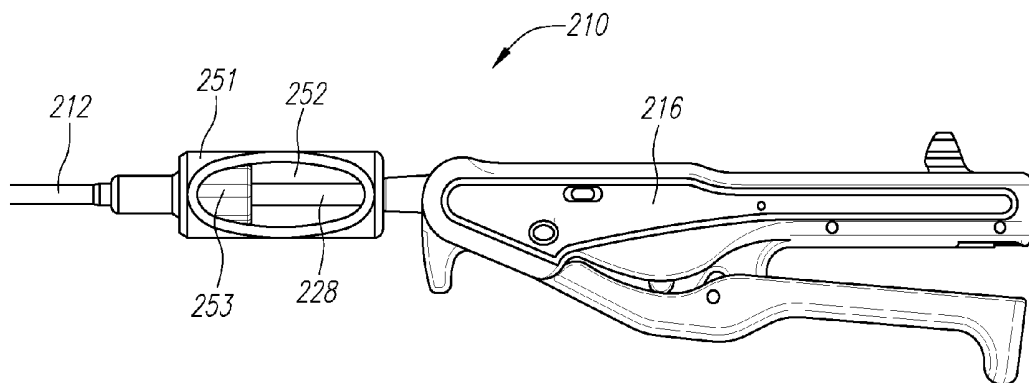

FIG. 12C

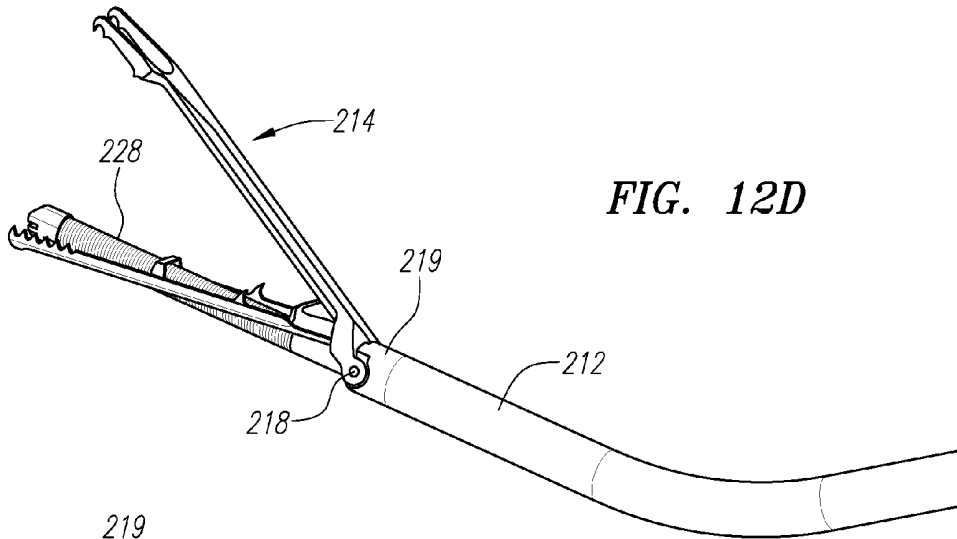

FIG. 12D

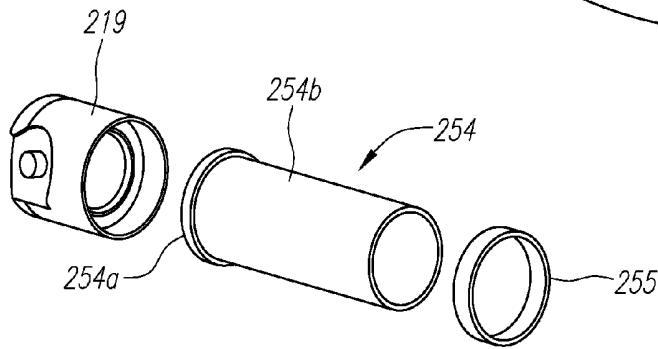

FIG. 12E

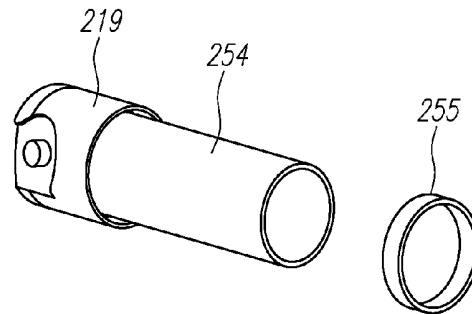

FIG. 12F

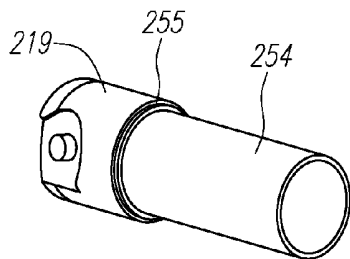
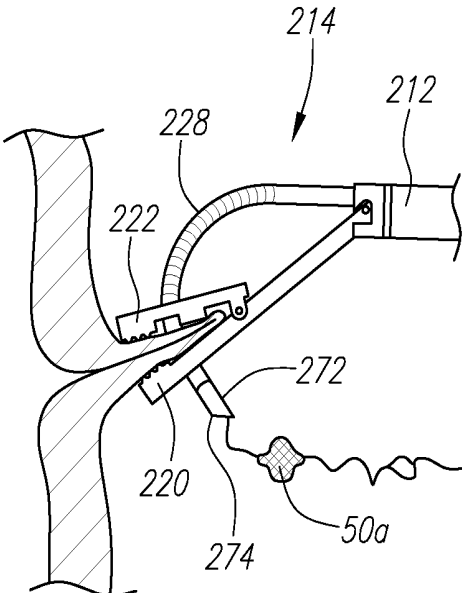

FIG. 12G



**FIG. 13**

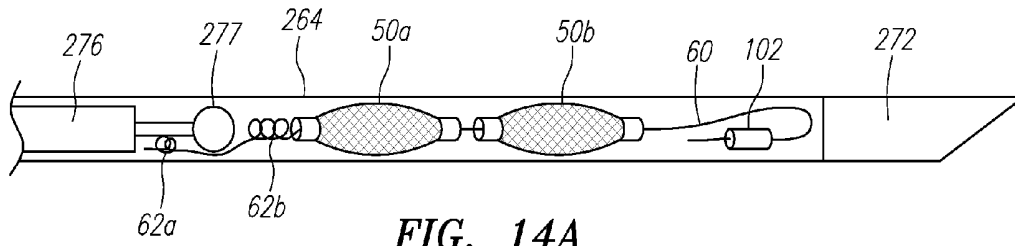

FIG. 14A

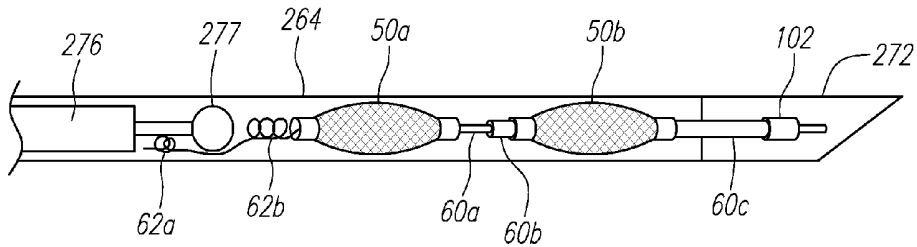

FIG. 14B

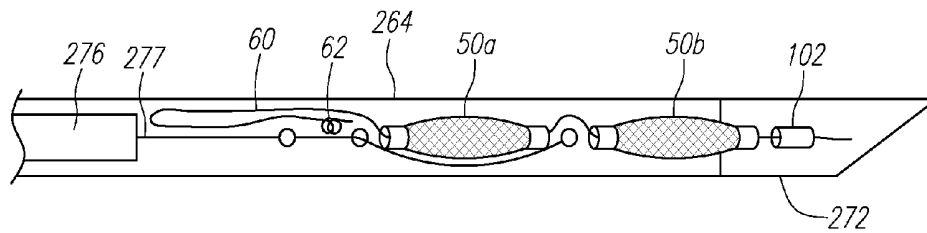

FIG. 14C

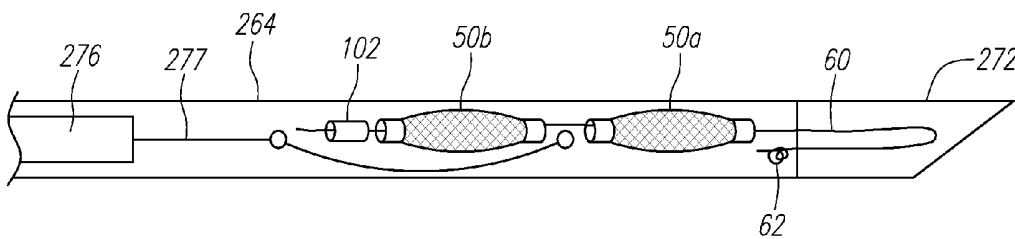
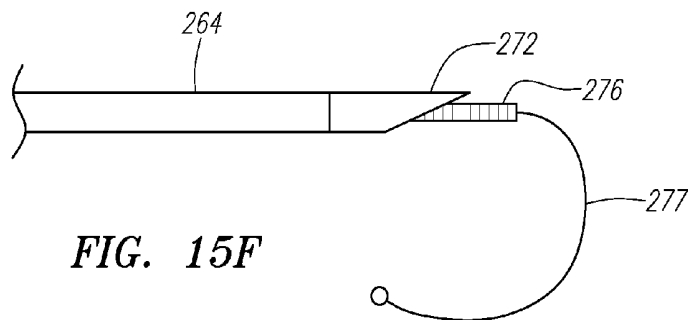
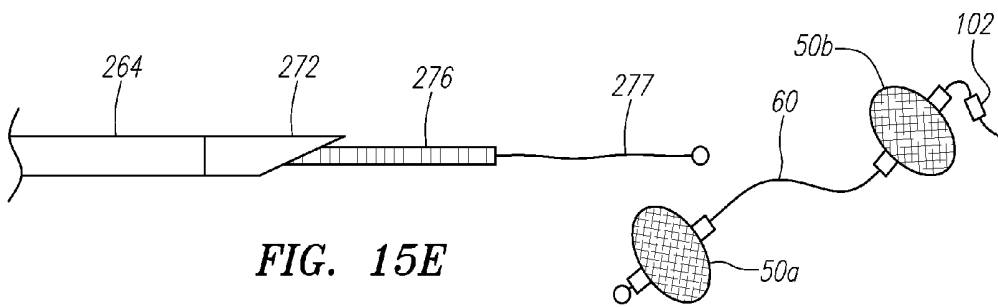
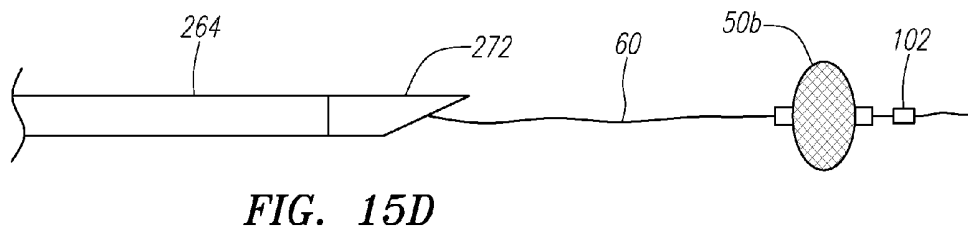
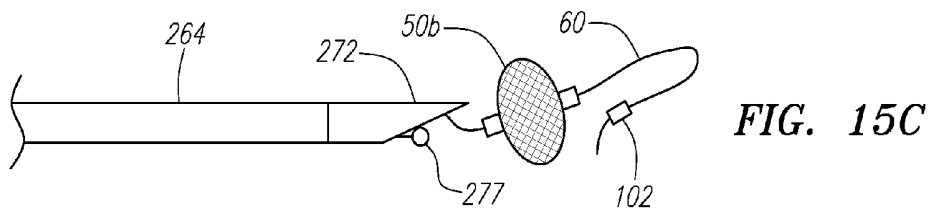
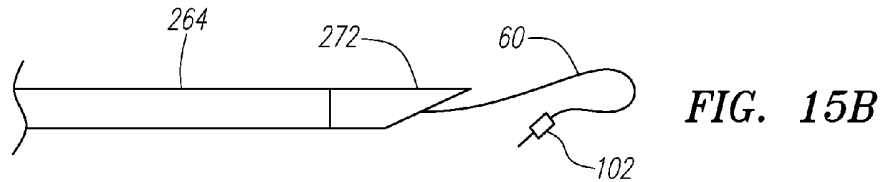
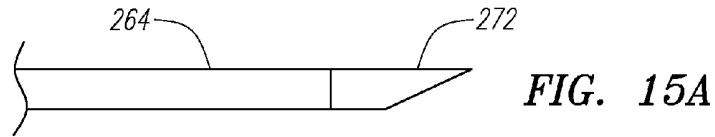

FIG. 14D



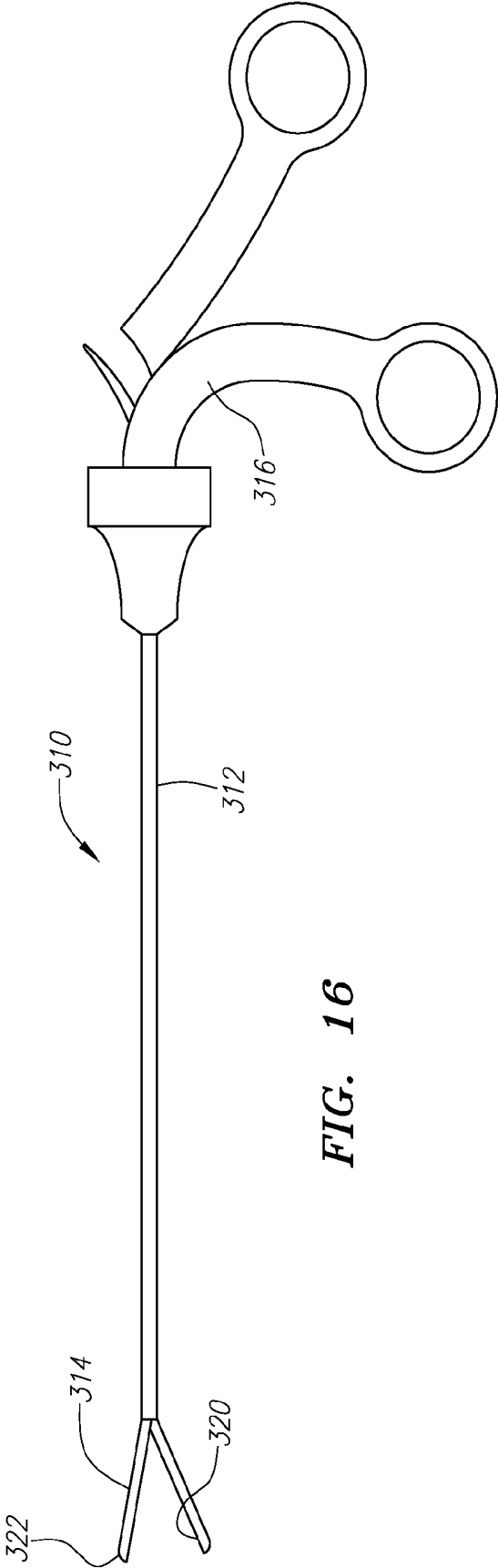

FIG. 16

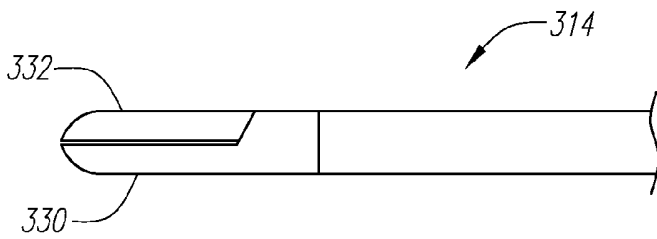

FIG. 17A

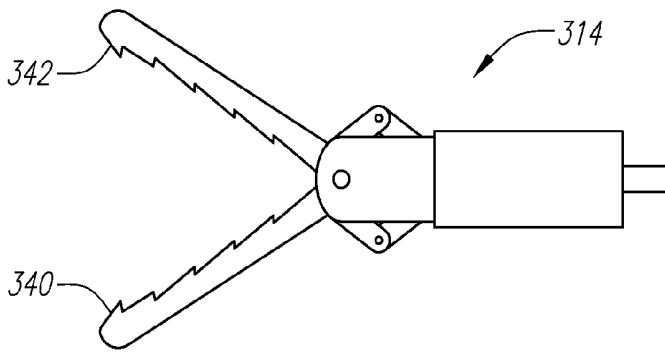

FIG. 17B

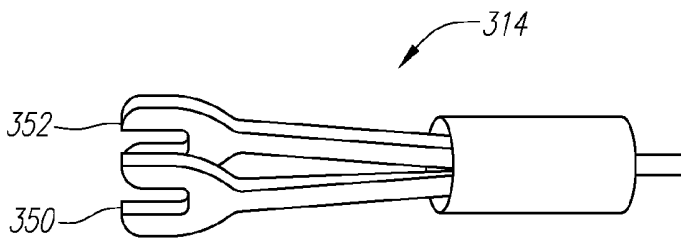

FIG. 17C

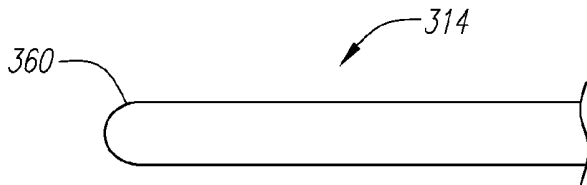

FIG. 17D

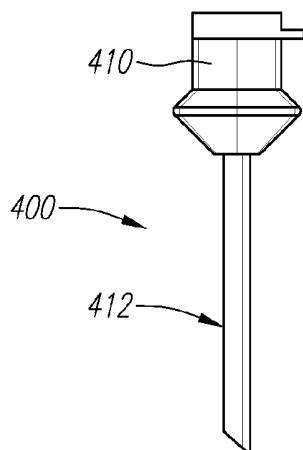

FIG. 18

FIG. 19

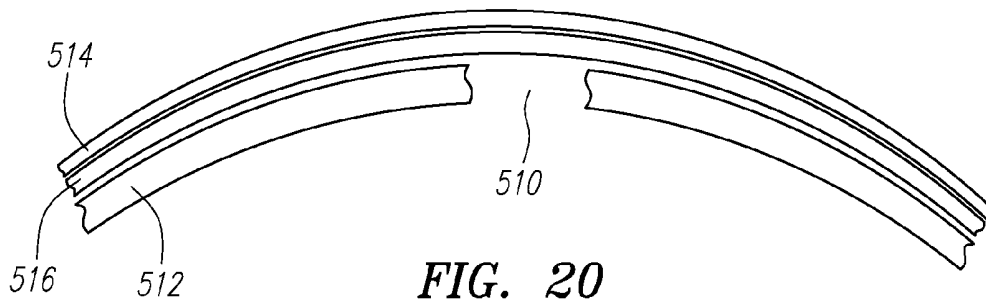
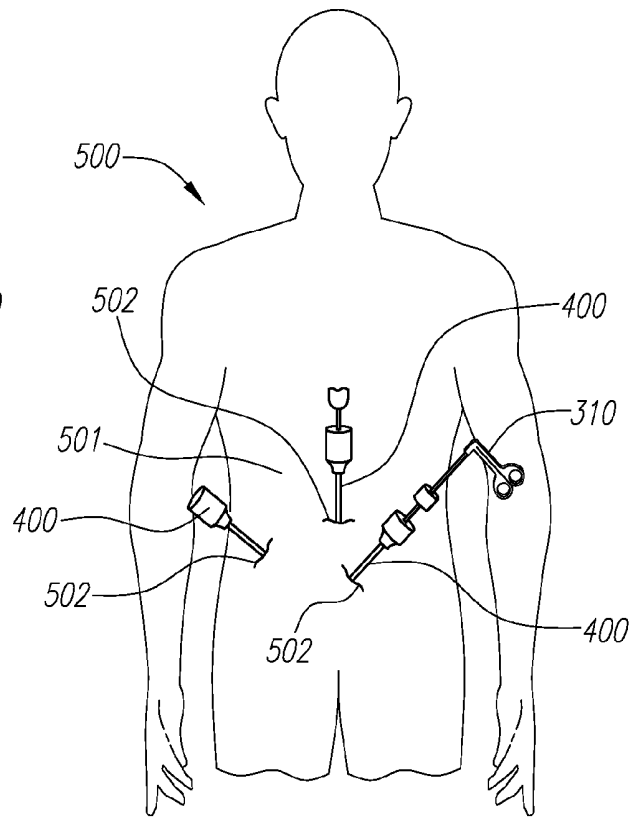

FIG. 20

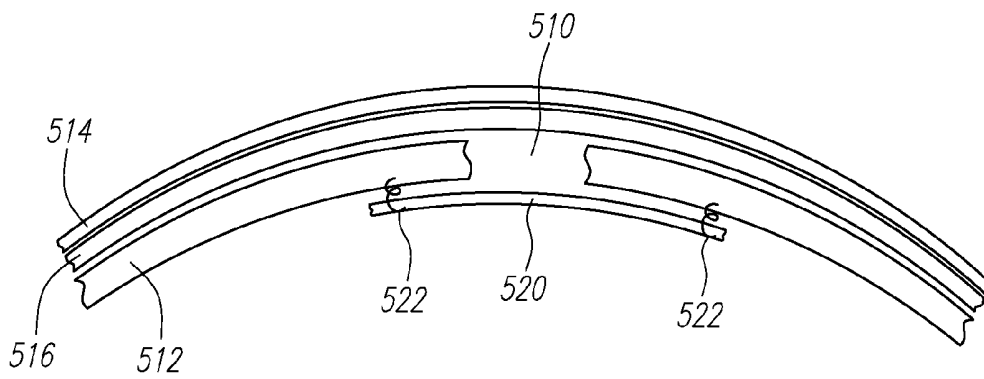

FIG. 21

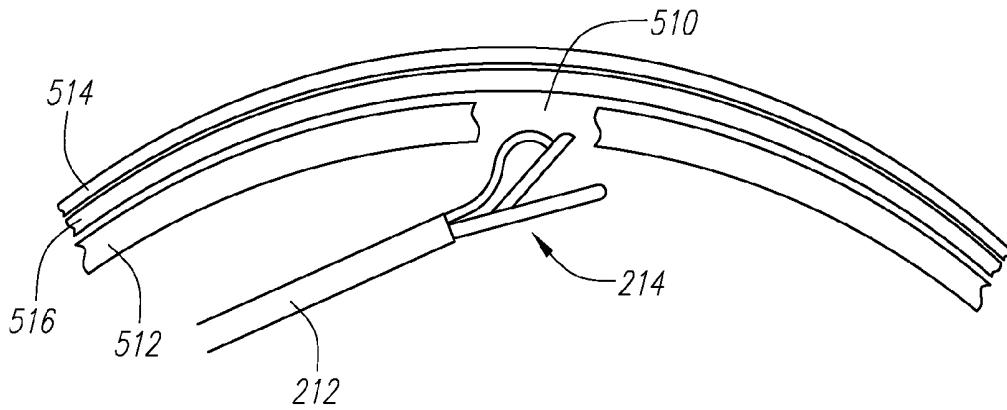

FIG. 22

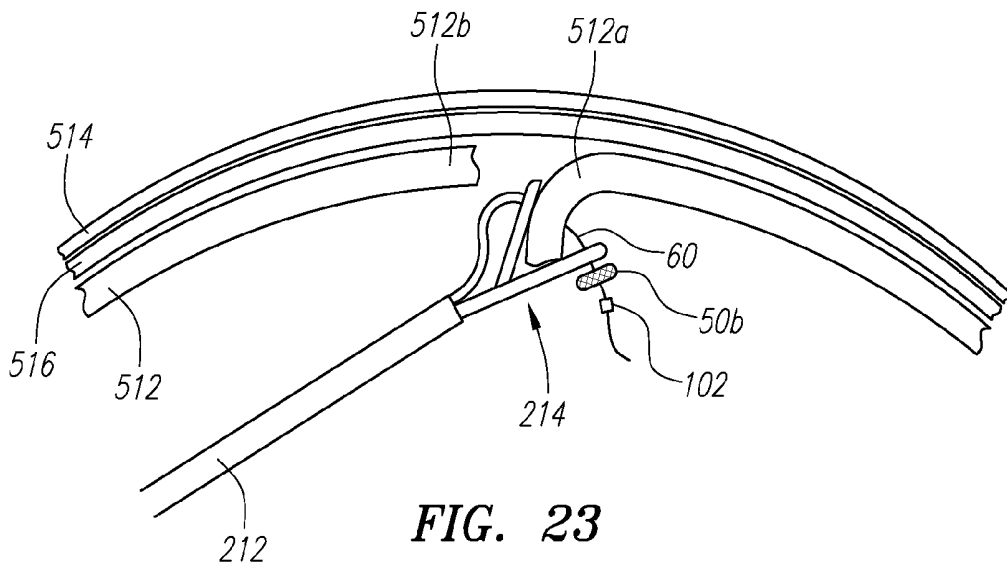

FIG. 23

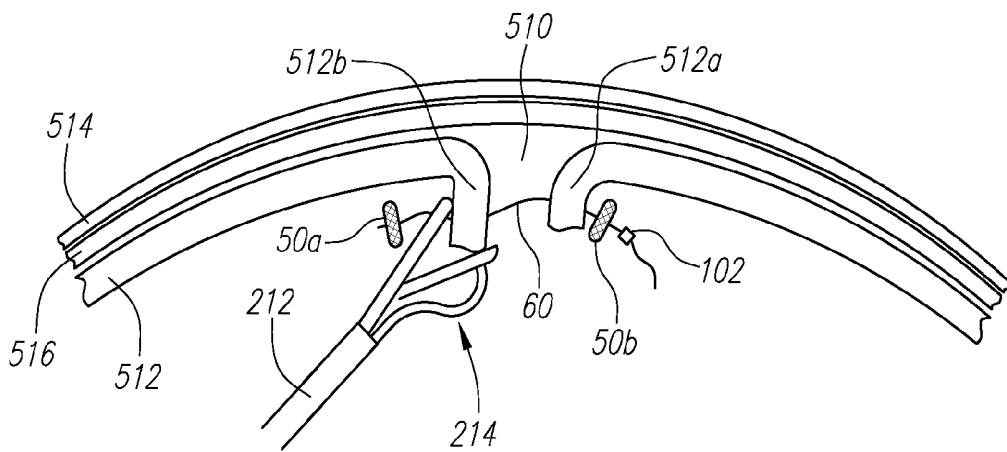

FIG. 24

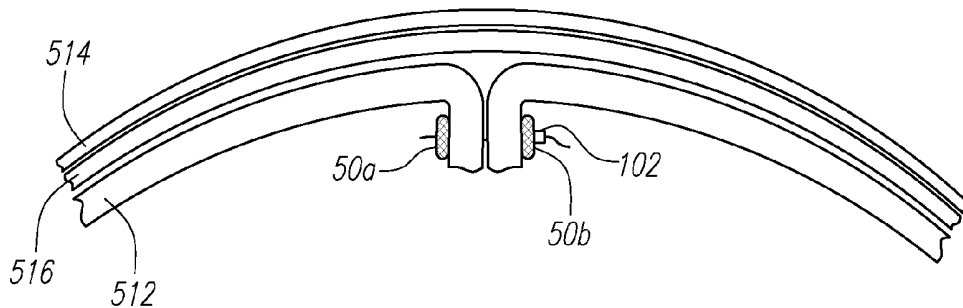

FIG. 25A

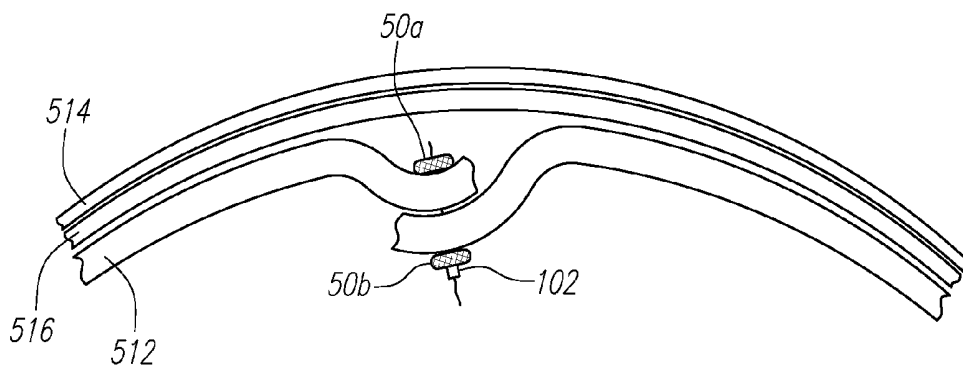

FIG. 25B

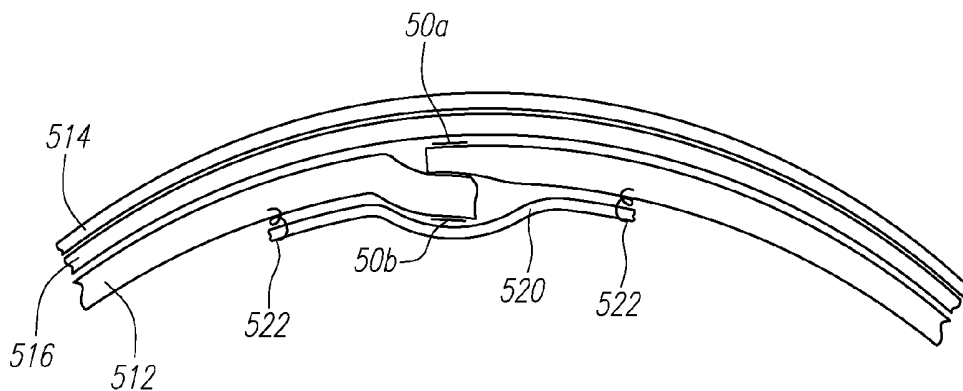

FIG. 26

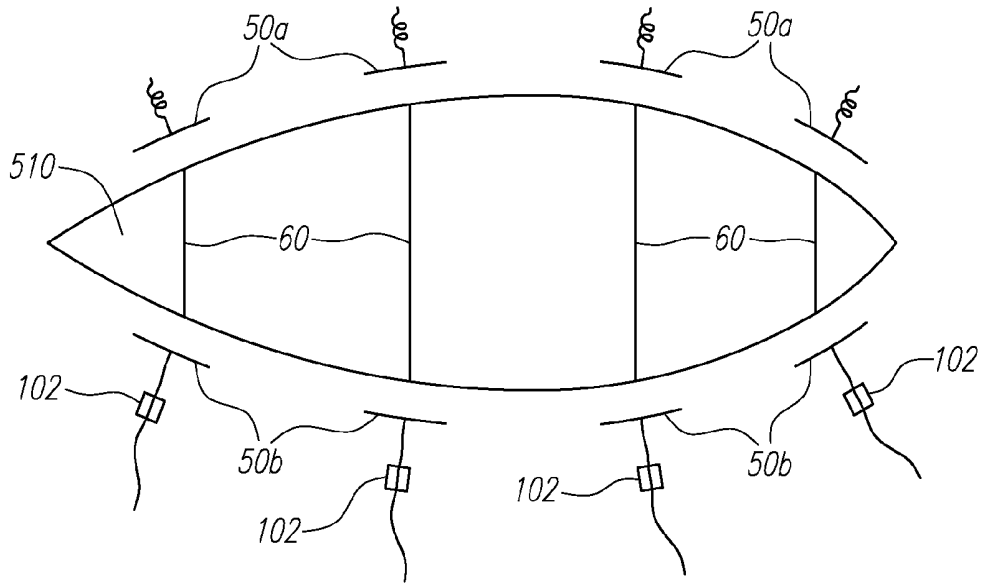

FIG. 27A

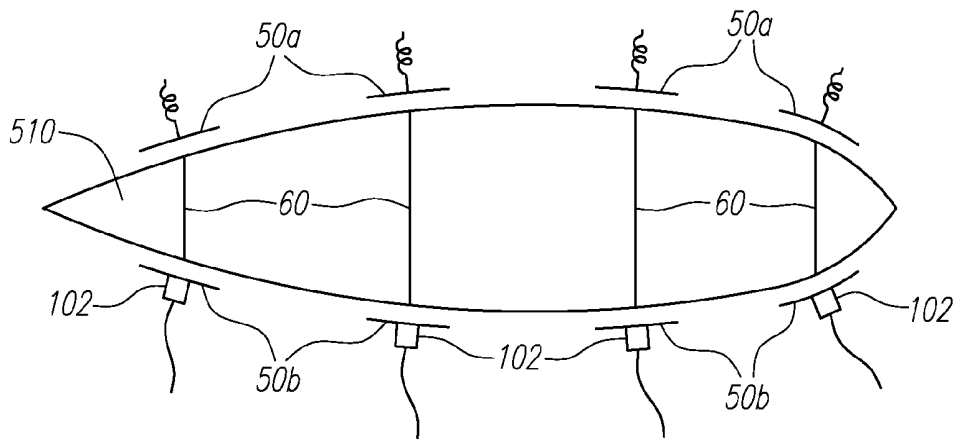

FIG. 27B

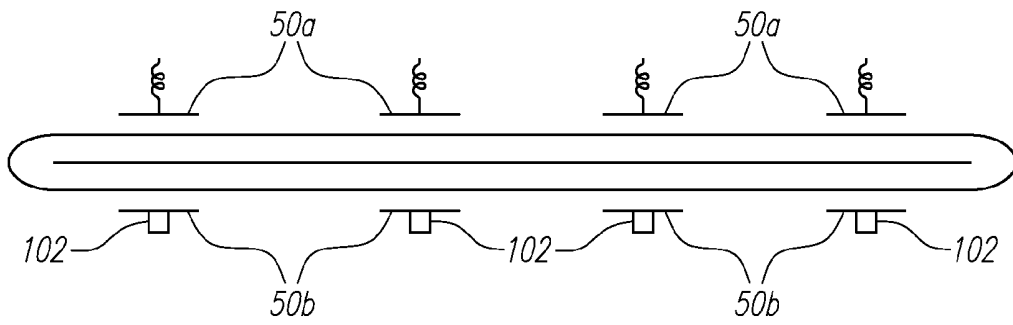

FIG. 27C

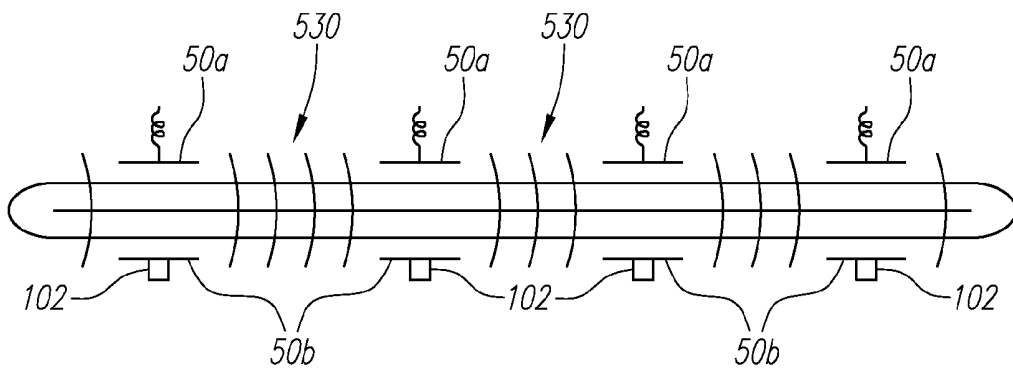

FIG. 27D

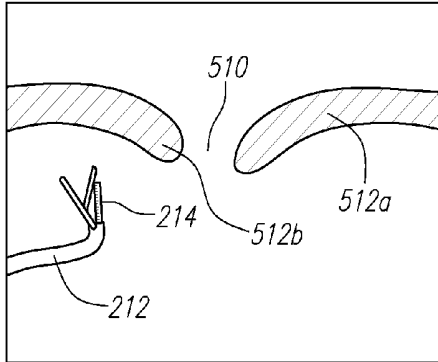

FIG. 28A

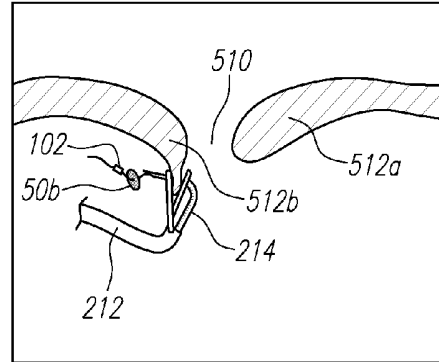

FIG. 28B

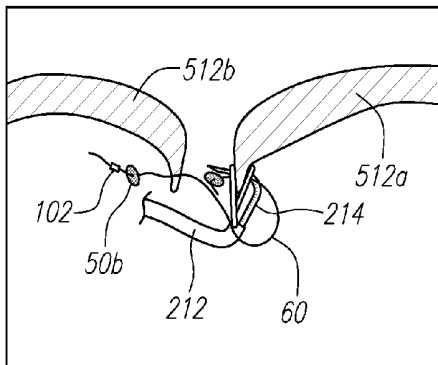

FIG. 28C

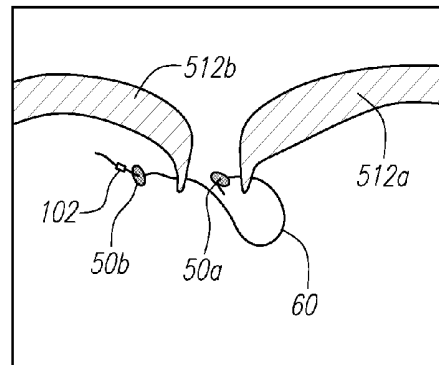

FIG. 28D

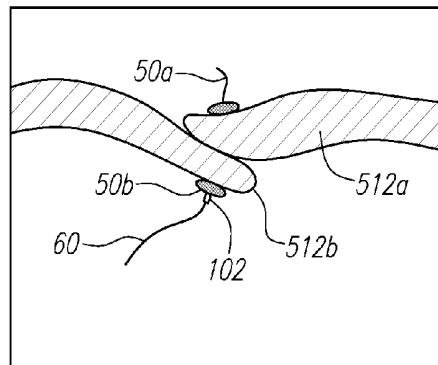

FIG. 28E

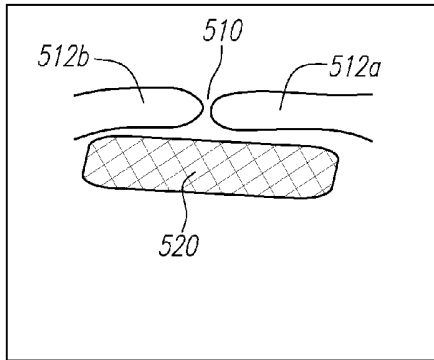

FIG. 29A

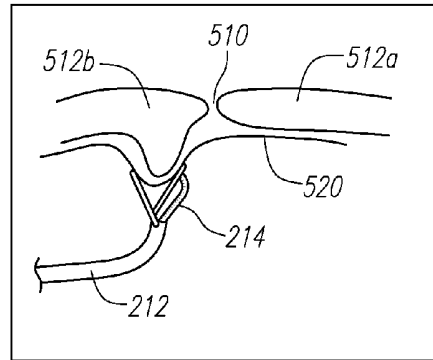

FIG. 29B

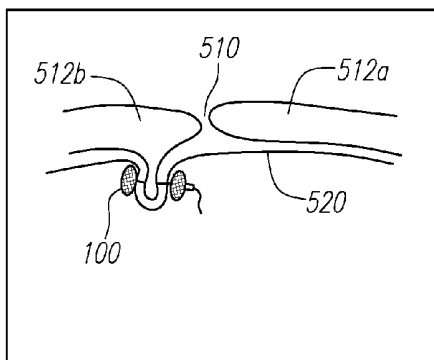

FIG. 29C

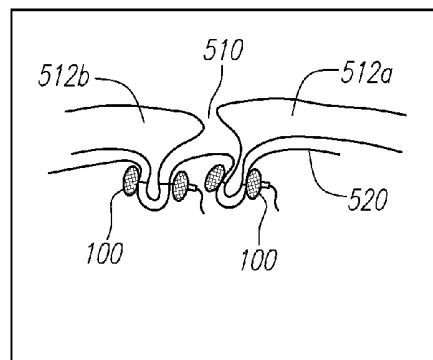

FIG. 29D

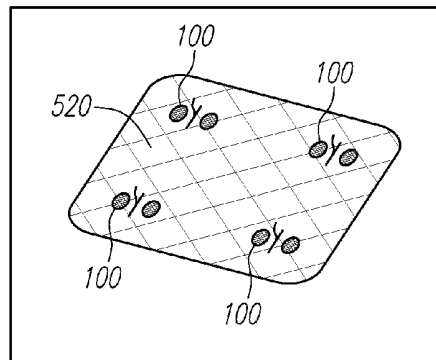

FIG. 29E

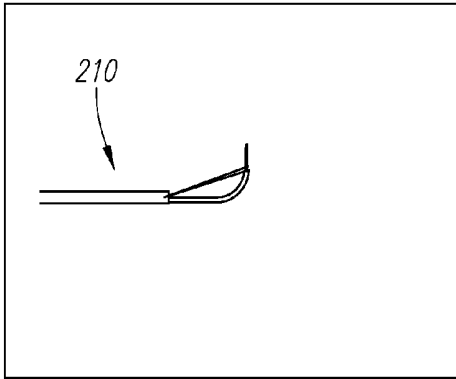

FIG. 30A

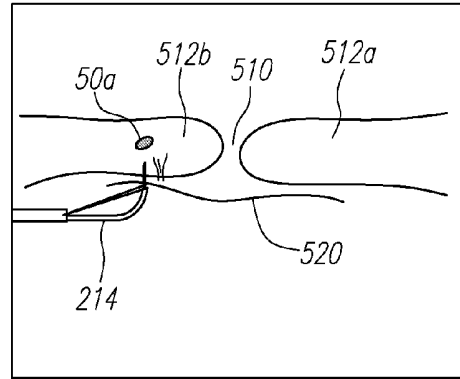

FIG. 30B

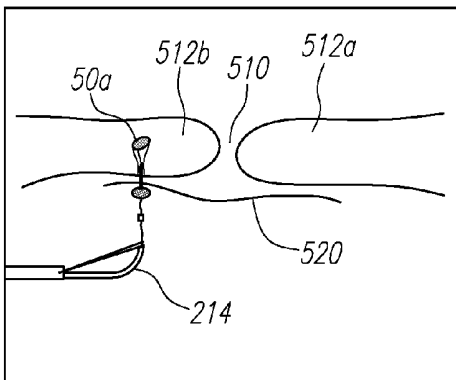

FIG. 30C

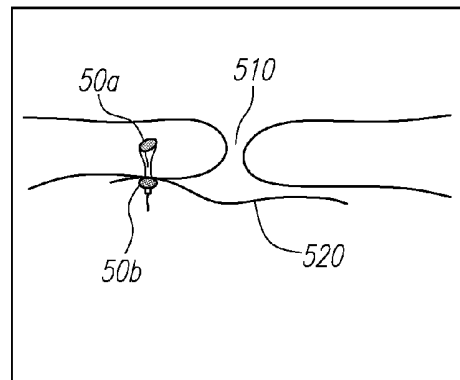

FIG. 30D

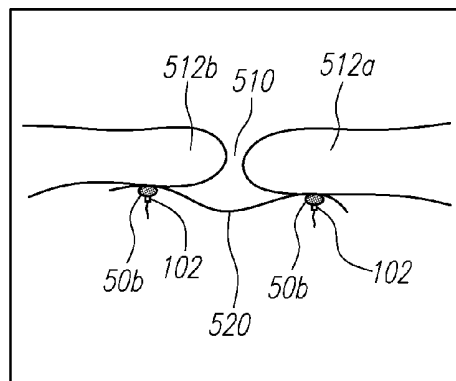

FIG. 30E

## DEVICES AND METHODS FOR LAPAROSCOPIC HERNIA REPAIR

### CROSS-REFERENCE TO RELATED APPLICATIONS

This application claims the benefit of priority to U.S. Provisional Patent Application No. 61/476,129, filed on Apr. 15, 2011, the contents of which are incorporated herein by reference in their entirety. This application also relates to U.S. Provisional Patent Application Ser. No. 61/307,376, filed on Feb. 23, 2010, and U.S. patent application Ser. No. 13/033,485, filed on Feb. 23, 2011, the contents of each of which are incorporated herein by reference in their entireties.

### BACKGROUND

A hernia is the protrusion of an organ or the fascia of an organ through the wall of the cavity that normally contains it. By far the most common hernias (up to 75% of all abdominal hernias) are the so-called inguinal hernias. Inguinal hernias are further divided into the more common indirect inguinal hernia, in which the inguinal canal is entered via a congenital weakness at its entrance (the internal inguinal ring), and the direct inguinal hernia type, where the hernia contents push through a weak spot in the back wall of the inguinal canal.

Femoral hernias occur just below the inguinal ligament, when abdominal contents pass into the weak area at the posterior wall of the femoral canal. They can be hard to distinguish from the inguinal type (especially when ascending cephalad): however, they generally appear more rounded, and, in contrast to inguinal hernias, there is a strong female preponderance in femoral hernias.

Higher in the abdomen, an (internal) “diaphragmatic hernia” results when part of the stomach or intestine protrudes into the chest cavity through a defect in the diaphragm. A hiatus hernia is a particular variant of this type, in which the normal passageway through which the esophagus meets the stomach (esophageal hiatus) serves as a functional “defect”, allowing part of the stomach to (periodically) “herniate” into the chest. Hiatus hernias may be either “sliding,” in which the gastroesophageal junction itself slides through the defect into the chest, or non-sliding (also known as para-esophageal), in which case the junction remains fixed while another portion of the stomach moves up through the defect. Non-sliding or para-esophageal hernias can be dangerous as they may allow the stomach to rotate and obstruct.

An incisional hernia can develop in the scar tissue around any surgery performed in the abdominal area, from the breastbone down to the groin. Depending upon the location of the hernia, internal organs may press through the weakened abdominal wall. The rate of incisional hernia occurrence can be as high as 13% with some abdominal surgeries. These hernias may occur after large surgeries such as intestinal or vascular (heart, arteries, and veins) surgery, or after smaller surgeries such as an appendectomy or a laparoscopy, which typically requires a small incision at the navel. Incisional hernias themselves can be very small or large and complex, involving growth along the scar tissue of a large incision. They may develop months after the surgery or years after, usually because of inadequate healing or excessive pressure on an abdominal wall scar. The factors that increase the risk of incisional hernia are conditions that increase strain on the abdominal wall, such as, obesity, advanced age, malnutrition, poor metabolism (digestion and assimilation of essential

nutrients), pregnancy, dialysis, excess fluid retention, and either infection or hematoma (bleeding under the skin) after a prior surgery.

Many procedures for hernia repair involve the permanent placement of surgical (prosthetic) mesh patches well beyond the edges of the weakened area or defect in the abdominal wall. The mesh is sewn or tacked to the area, bridging the hole or weakened area. As the area heals, the mesh is intended to become firmly integrated into the inner abdominal wall membrane (peritoneum) that protects the organs of the abdomen. Autogenous tissue (skin from the patient’s own body) has also been used for this type of repair.

Two surgical approaches are used to treat incisional hernias: either a laparoscopic incisional herniorrhaphy, which uses small incisions and a laparoscope; or a conventional open repair procedure, which accesses the hernia through a larger abdominal incision. Open procedures may be necessary if the intestines have become trapped in the hernia (incarceration) or the trapped intestine has become twisted and its blood supply cut off (strangulation). Extremely obese patients may also require an open procedure because deeper layers of fatty tissue will have to be removed from the abdominal wall. Mesh may be used with both types of surgical access.

In both open and laparoscopic procedures, the patient lies on the operating table, either flat on the back or on the side, depending on the location of the hernia. General anesthesia is usually given, though some patients may have local or regional anesthesia, depending on the location of the hernia and complexity of the repair. A catheter may be inserted into the bladder to remove urine and decompress the bladder. If the hernia is near the stomach, a gastric (nose or mouth to stomach) tube may be inserted to decompress the stomach.

In an open procedure, an incision is made just large enough to remove fat and scar tissue from the abdominal wall near the hernia. The outside edges of the weakened hernial area are defined and excess tissue removed from within the area. Mesh is then applied so that it overlaps the weakened area by several inches (centimeters) in all directions. Non-absorbable sutures are placed into the full thickness of the abdominal wall. The sutures are tied down and knotted.

In the less-invasive laparoscopic procedure, multiple small incisions will be made to access the hernia site—the laparoscope is inserted in one incision and surgical instruments in the others to remove tissue and place the mesh in the same fashion as in an open procedure. Significantly less abdominal wall tissue is removed in laparoscopic repair. The surgeon views the entire procedure on a video monitor to guide the placement and attachment of the mesh.

Patients will usually go home the day of surgery and can expect a one- to two-week recovery period at home, and then a return to normal activities. Although good outcomes are expected with incisional hernia repair, particularly with the laparoscopic method, recurrence rates after the first repair of an incisional hernia can range from 25-52%.

### SUMMARY

In a first aspect, laparoscopic hernia repair includes a number of methods and devices. The devices are introduced laparoscopically (e.g., via one or more trocars, etc.) into the patient’s body and into the peritoneal cavity to approach the weakened area or defect in the fascia. Once the instruments are positioned near the hernia defect, the edges of the fascia surrounding the defect are temporarily engaged and/or grasped and the engaged tissue is manipulated by a surgeon or practitioner from outside the patient’s body. One or more

tissue fasteners, such as one or more tissue anchor assemblies each including a pair of anchors connected to each other by a suture, are deployed across the hernia defect. The pair of anchors or other tissue fasteners are approximated and secured, thereby bringing the edges of the fascia surrounding the defect relatively closer to one another. In some embodiments, the fascia edges are brought into side-by-side or overlapping contact with one another. In some embodiments, a surgical mesh is then deployed laparoscopically across the defect.

In engaging, manipulating, and/or securing the tissue, various methods and devices may be implemented. For instance, a tissue securement device may be delivered and positioned through the abdominal wall via one or more trocars. In some embodiments, the tissue securement device includes an end effector suitable for contacting the edges of the fascia surrounding the hernia defect, manipulating the fascia tissue, and/or deploying one or more tissue anchors through the fascia. The tissue anchor(s) extending on a connecting member (e.g., a suturing element) may be disposed through opposed edges of the fascia. A tissue manipulation assembly positioned at the distal end of a tissue securement device may be used for engaging the fascia tissue and deploying the tissue anchor to secure the tissue with the tissue anchor. A second tissue anchor may then be deployed in a second region of the fascia, after which the fascia tissue regions are brought into apposition by decreasing the length of the connecting member extending between the two tissue anchors. In some embodiments, this is done by advancing an uni-directional cinching element or other locking mechanism along the connecting member. In some embodiments, the foregoing method is repeated at a plurality of locations along the length of the hernia defect.

In some embodiments, the laparoscopic hernia repair method includes at least the following steps:

- laparoscopically introducing a tissue approximation device into the peritoneal cavity and into the vicinity of a hernia defect;
- approximating a first region of tissue at or near a first edge of the hernia defect and a second region of tissue at or near a second edge of the hernia defect with the tissue approximation device; and
- securing the approximated first and second regions of tissue with a first tissue fastener.

Some examples of the foregoing hernia repair method include one or more of the following additional steps:

- securing the approximated first and second regions of tissue with a plurality of additional tissue fasteners;
- oversewing the approximated first and second regions of tissue after securing the first and second regions of tissue;
- applying a surgical mesh over the approximated first and second regions of tissue and securing the surgical mesh to tissue in the vicinity of the first and second regions of tissue.

In other embodiments, the laparoscopic hernia repair method includes the steps of:

- laparoscopically introducing a tissue fastener into the peritoneal cavity and into the vicinity of a hernia defect;
- deploying a first portion of the tissue fastener into or through a first region of tissue at or near a first edge of the hernia defect;
- deploying a second portion of the tissue fastener into or through a second region of tissue at or near a second edge of the hernia defect; and

approximating the first and second portions of the tissue fastener to thereby approximate the first and second regions of tissue.

Some examples of the foregoing hernia repair method include one or more of the following additional steps:

- deploying a plurality of additional tissue fasteners into or through the first and second regions of tissue;
- oversewing the approximated first and second regions of tissue after approximating the first and second regions of tissue;
- applying a surgical mesh over the approximated first and second regions of tissue and securing the surgical mesh to tissue in the vicinity of the first and second regions of tissue.

In some embodiments, each of the foregoing embodiments of the laparoscopic hernia repair method is performed using a tissue fastener that includes a tissue anchor assembly having first and second tissue anchors and a locking mechanism retained on a connecting member, such as a suture. In some embodiments, at least one of the tissue anchors and the locking mechanism are movable on the connecting member, thereby facilitating approximation of the tissue anchors along the connecting member.

#### BRIEF DESCRIPTION OF THE DRAWINGS

FIG. 1 is a schematic representation of a tissue anchor assembly.

FIGS. 2A and 2B are schematic representations of a tissue anchor assembly securing a pair of tissue regions.

FIG. 3 is an exploded view of a first embodiment of an anchor deployment catheter.

FIG. 4 is a perspective view of a second embodiment of an anchor deployment catheter.

FIG. 5 is a side view of a third embodiment of an anchor deployment catheter.

FIG. 6 is a side view of a laparoscopic tissue manipulation and anchor deployment device.

FIG. 7 is a side view of a first embodiment of a handle portion of the laparoscopic tissue manipulation and anchor deployment device of FIG. 6.

FIG. 8 is a perspective view of second embodiment of a handle portion of the laparoscopic tissue manipulation and anchor deployment device of FIG. 6.

FIGS. 9A through 9E are perspective and side views of embodiments of end effectors of the laparoscopic tissue manipulation and anchor deployment device of FIG. 6.

FIG. 10A is a side view of another embodiment of a laparoscopic tissue manipulation and anchor deployment device.

FIG. 10B is a side view of a distal region of the laparoscopic tissue manipulation and anchor deployment device shown in FIG. 10A.

FIG. 10C is a side view of a distal region of the laparoscopic tissue manipulation and anchor deployment device shown in FIG. 10A shown with a portion of the tubular body removed for clarity.

FIG. 11A is a side view of another embodiment of a laparoscopic tissue manipulation and anchor deployment device.

FIG. 11B is a side view of a portion of a spring-loaded variable spacer of the laparoscopic tissue manipulation and anchor deployment device shown in FIG. 11A, shown with the spring and piston sleeve removed for clarity.

FIG. 11C is a side view of a spring-loaded variable spacer of the laparoscopic tissue manipulation and anchor deployment device shown in FIG. 11A.

FIGS. 12A-C are perspective and two side views, respectively, of an embodiment of a laparoscopic tissue manipulation and anchor deployment device having a distal end effector rotation mechanism.

FIG. 12D is a side view of a distal end effector of the laparoscopic tissue manipulation and anchor deployment device shown in FIG. 12A.

FIGS. 12E-G are perspective views of a rotatable connection between the distal end effector and the tubular body of the laparoscopic tissue manipulation and anchor deployment device shown in FIG. 12A.

FIG. 13 is a side view of the distal end effector of an embodiment of the laparoscopic tissue manipulation and anchor deployment device of FIG. 6 deploying a tissue anchor assembly through a region of tissue.

FIGS. 14A-D are side cross-sectional view of four embodiments of an anchor retention mechanism.

FIGS. 15A-F are illustrations of the progression of an anchor deployment method using an anchor retention mechanism.

FIG. 16 is a side view of a laparoscopic instrument.

FIGS. 17A through 17D are side views of alternative end effectors for the laparoscopic instrument of FIG. 16.

FIG. 18 is a side view of a trocar.

FIG. 19 is a top view illustrating a laparoscopic procedure being performed on a patient.

FIG. 20 is a cross-sectional view showing a hernia defect in the fascia tissue of a patient.

FIG. 21 is a cross-sectional view showing the hernia defect of FIG. 20 after deployment of a surgical mesh.

FIGS. 22-24 are cross-sectional views showing the progression of a portion of a laparoscopic hernia repair procedure.

FIGS. 25A-B are cross-sectional views showing a tissue anchor assembly deployed through opposed edges of fascia tissue in a side-by-side orientation and an overlapping orientation, respectively.

FIG. 26 is a cross-sectional view of a repaired incisional hernia.

FIGS. 27A-D are illustrations showing several stages of an incisional hernia repair as viewed, for example, through a laparoscope located in the peritoneum of the patient and directed toward the hernia defect.

FIGS. 28A-E are cross-sectional views showing the progression of a portion of a laparoscopic hernia repair procedure.

FIGS. 29A-E are cross-sectional views showing the progression of a portion of a laparoscopic hernia repair procedure.

FIGS. 30A-E are cross-sectional views showing the progression of a portion of a laparoscopic hernia repair procedure.

DETAILED DESCRIPTION

Laparoscopic surgical devices and methods for engaging, manipulating, reconfiguring, and securing tissue are described herein. In several embodiments, the methods entail performing surgery through one or a limited number of trocars, eliminating the need for an open surgical procedure. Laparoscopic procedures provide faster healing times, less scarring, and less pain which could lead to reduced hospitalization and quicker recovery in comparison to most open surgical procedures.

In several embodiments, the laparoscopic surgical procedures are performed using devices that have been developed by USGI Medical, Inc. of San Clemente, Calif. Several tissue

manipulation and tissue anchor delivery devices are described in the following United States patent applications:

TABLE 2

U.S. patent application Ser. No.	Filing Date
10/612,109	Jul. 1, 2003
10/639,162	Aug. 11, 2003
10/672,375	Sept. 26, 2003
10/734,547	Dec. 12, 2003
10/734,562	Dec. 12, 2003
10/735,030	Dec. 12, 2003
10/840,950	May 7, 2004
10/955,245	Sept. 29, 2004
11/070,863	Mar. 1, 2005
12/486,578	Jun. 17, 2009

The foregoing applications describe several tissue manipulation and tissue anchor delivery devices and embodiments, including flexible devices used for endolumenal procedures.

Several tissue anchor delivery devices suitable for laparoscopic use are described more fully below.

Endolumenal tissue grasping devices are described in several of the United States patent applications listed above, and in the following United States patent applications:

TABLE 3

U.S. patent application Ser. No.	Filing Date
11/736,539	Apr. 17, 2007
11/736,541	Apr. 17, 2007

Tissue anchors are described in several of the United States patent applications listed above, and in the following United States patent applications:

TABLE 4

U.S. patent application Ser. No.	Filing Date
10/612,170	Jul. 1, 2003
10/841,411	May 7, 2004
11/404,423	Apr. 14, 2006
11/773,933	Jul. 5, 2007

Each of the foregoing patent applications is hereby incorporated by reference in its entirety.

Tissue Anchors and Delivery Devices and Methods

Several embodiments of the laparoscopic surgical procedures described herein include the steps of acquiring (e.g., by grasping) a first region of tissue, deploying or implanting a first fastener (e.g., a first tissue anchor of a tissue anchor assembly) into or through the first region of tissue, acquiring (e.g., by grasping) a second region of tissue, deploying or implanting a second fastener (e.g., a second tissue anchor of a tissue anchor assembly) into or through the second region of tissue, then approximating the first and second fasteners to cause the first and second tissue regions to be brought into proximity relative to one another. For simplicity, the discussion herein will describe tissue anchor assemblies holding regions of tissue comprising or adjacent to an incisional/ventral hernia, with it being understood that regions of tissue associated with other types of hernias or portions or sections of tissue in other regions of the body of a patient are suitably retained by the tissue anchor assemblies and other fasteners described herein. The following sections include descriptions

of several embodiments of devices that are suitable for performing these and other laparoscopic surgical procedures.

In several embodiments, a plurality of tissue anchor assemblies are used to approximate regions of tissue on opposed sides of an incisional/ventral or other type of hernia. In some embodiments, the tissue anchor assemblies include tissue anchors such as those described in several of the United States patent applications incorporated by reference above, including Ser. Nos. 10/612,170, 10/841,411, 11/404,423, and 11/773,933. In other embodiments, the tissue anchor assemblies include “T”-anchors, basket anchors, and other types of anchors known to those skilled in the art. A schematic representation of a suitable tissue anchor assembly is shown in FIG. 1. In still other embodiments, regions of tissue are approximated using staples, tacks, clips, rivets, sutures, “H”-fasteners, “T”-tags, barbed or quilled suture, combinations of the foregoing, and/or other types of fasteners known to those skilled in the art. For clarity, the descriptions contained in this disclosure will focus on tissue anchors and tissue anchor assemblies, with the understanding that the methods and processes described herein are not intended to be limited to tissue anchor assemblies unless otherwise stated.

In some embodiments, the tissue anchor assemblies include a pair of tissue anchors **50a**, **50b** slidably retained by a connecting member, such as a suture **60**. The suture **60** may be formed of conventional materials, such as polyglycolic acid, polylactic acid, polydioxanone, nylon, polypropylene. In other embodiments, the connecting member or suture **60** is formed of stainless steel, Nitinol, or other suitable material. In other embodiments, one or both of the tissue anchors **50a**, **50b** are retained at a fixed location on the connecting member. In still other embodiments, each of the tissue anchors is retained on a separate suture **60** and the separate sutures are connected together by tying, knotting, locking, or other securement mechanism. In the FIG. 1 embodiment, a locking mechanism, such as a cinch **102**, is also slidably retained on the suture **60**. The cinch **102** is configured to be slidable on the suture **60** in only a single direction (one-way or uni-directional), in particular, toward the distal end of the suture. Several types of cinches and other locking mechanisms—and their structures and modes of operation—are described in several of the United States Patent Applications incorporated by reference above, including Ser. Nos. 10/612,170, 10/612,491, 10/841,411, 11/404,423, and 11/773,933. The cinch **102** or other locking mechanism is configured to provide a cinching force against the anchors **50a**, **50b** in order to impart a tension force on the suture. Accordingly, the tissue anchor assembly **100** is adapted to hold two regions of tissue together or in proximity to one another, as shown in FIGS. 2A and 2B. In addition, as described below, the position of the cinch **102** or other locking mechanism on the suture **60** is able to be adjusted by the user during deployment of the tissue anchor assembly, thereby allowing the user to adjust the amount of tension force applied to the suture **60**, and the amount of force that the anchors **50a**, **50b** impart to the regions of tissue T1, T2.

The tissue anchor assembly **100** may be used to maintain regions of tissue in at least two relative orientations. In a first orientation (referred to herein as a “side-by-side” orientation), shown in FIG. 2A, a first tissue region T1 is secured to a second region of tissue T2 by causing the ends of the tissue regions to be brought substantially together and the anchor assembly **100** or other tissue fastener is deployed through both tissue regions T1, T2 such that both tissue anchors **50a**, **50b** of the tissue anchor assembly **100** or other tissue fastener remain on the same side (e.g., the upper side as shown in FIG. 2A) of the two regions of tissue T1, T2 after they are brought substantially together. In a second orientation (referred to

herein as an “overlapping” orientation), shown in FIG. 2B, a first tissue region T1 is secured to a second tissue region T2 by causing the ends of the tissue regions to be overlapped and the anchor assembly **100** or other tissue fastener deployed through both tissue regions T1, T2 such that a first tissue anchor **50a** is located on a first side (e.g., the upper side as shown in FIG. 2B) of the two regions of tissue T1, T2 and a second tissue anchor **50b** is located on a second side (e.g., the lower side as shown in FIG. 2B) of the two regions of tissue T1, T2 after they are brought substantially together. As described below, a surgeon or other user deploying tissue anchor assemblies **100** or other tissue fasteners may select one of the foregoing orientations, or another orientation, in order to secure tissue regions in a particular manner or to achieve another desired result.

In several embodiments, a delivery device is used to deploy the tissue anchors and tissue anchor assemblies **100** or other tissue fasteners laparoscopically. An example of a suitable delivery device is shown in FIGS. 3-8. Embodiments of the device shown in FIGS. 3-8 but having a flexible shaft for use in endoluminal procedures are described in substantial detail in U.S. patent application Ser. No. 12/486,578, which is hereby incorporated by reference in its entirety (including all references cited therein) as if fully set forth herein. The laparoscopic embodiment of the delivery device **208** is described briefly below. In other embodiments, one or more tissue fasteners are deployed using one or more delivery/deployment devices suitable for deploying the particular type of tissue fastener desired (e.g., staplers, clip applicators, tack or rivet deployment devices, other types of anchor deployment devices, and the like). In still other embodiments, a tissue fastener deployment device includes or is used in combination with a device used to approximate two or more regions of tissue. For clarity, the descriptions contained in this disclosure will focus on the tissue anchor delivery device shown in FIGS. 3-8, with the understanding that the methods and processes described herein are not intended to be limited to these delivery devices unless otherwise stated.

Turning to the device shown in FIGS. 6-8, in manipulating tissue or creating tissue folds, a device having a handle **216**, a substantially rigid shaft **212**, and a distal end effector **214** is advanced laparoscopically, e.g., via a trocar, etc., into the patient’s body, e.g., through the abdominal wall and into the peritoneal cavity. The end effector **214** is moved to the site of the target tissue, e.g., the location of a ventral hernia. The target tissue may be engaged or grasped and the engaged tissue may be manipulated by a surgeon or practitioner from outside the patient’s body. Examples of grasping and manipulating target tissue are described in further detail in the ’578 application incorporated by reference above, as well as in U.S. patent application Ser. No. 10/955,245, filed Sep. 29, 2004, which is also incorporated herein by reference, as well as U.S. patent application Ser. No. 10/735,030, filed Dec. 12, 2003, which is also incorporated herein by reference in its entirety.

The delivery device **208** shown in FIGS. 6-8 generally comprises a tissue manipulation assembly **210** and a needle deployment assembly **260**. (Embodiments of the needle deployment assembly **260** are shown in FIGS. 3-5 and are described more fully below). The tissue manipulation assembly **210** includes a tubular body **212** that is configured to be substantially rigid for laparoscopic advancement via a trocar into the peritoneal cavity. The tubular body **212** is configured to be torqueable through various methods, e.g., utilizing a stainless steel or other substantially rigid tubular construction, such that when a handle **216** is manipulated and/or rotated by a practitioner from outside the patient’s body, the

longitudinal and/or torquing force is transmitted along the body **212** such that the distal end of the body **212** is advanced, withdrawn, or rotated in a corresponding manner.

A tissue manipulation end effector **214** is located at the distal end of the tubular body **212** and is generally used to contact and form tissue folds and/or to otherwise bring portions of tissue into apposition. Several embodiments of the distal end effector are shown in FIGS. 9A-E. In some embodiments, the tissue manipulation end effector **214** is connected to the distal end of the tubular body **212** via a pivotable coupling **218** formed on or attached to a manifold **219**. A lower jaw member **220** extends distally from the pivotable coupling **218** and an upper jaw member **222**, in this example, is pivotably coupled to the lower jaw member **220** via a jaw pivot **226**. The location of the jaw pivot **226** may be positioned at various locations along the lower jaw **220** depending upon a number of factors, e.g., the desired size of the “bite” or opening for accepting tissue between the jaw members, the amount of closing force between the jaw members, etc. In other embodiments, the end effector **214** is connected to the distal end of the tubular body in a non-pivoting manner in which the lower jaw **220** is fixedly attached to the tubular body **212**. One or both jaw members **220**, **222** may optionally include a number of protrusions, projections, grasping teeth, textured surfaces, etc. on the surface or surfaces of the jaw members **220**, **222** facing one another to facilitate the adherence of tissue between the jaw members **220**, **222**. In alternative embodiments, the surfaces of the jaw member **220**, **222** are provided with a smooth, textured, or other atraumatic surface in order to decrease or eliminate the incidence of tissue injury.

Turning to FIGS. 9C-E, three additional embodiments of the tissue manipulation end effector **214** are shown. For clarity, the tubular body **212** and launch tube **228** are not shown in the drawings. In the embodiment shown in FIG. 9D, the upper jaw **222** is pivotably coupled to the lower jaw **220** via a jaw pivot **226** that is fixedly attached to the lower jaw **220**, as described above in relation to FIGS. 9A-B. In the embodiment shown in FIGS. 9C and 9E, a slotted jaw construction includes a jaw pivot **226** that is able to slide within an upright slot **232** formed in the frame of the lower jaw **220**. In an alternative embodiment not shown, the jaw pivot **226** is fixed to the lower jaw **220** and slides within a slot **232** formed on the frame of the upper jaw **222**. The capability of the jaw pivot **226** to slide within the upright slot **232** provides the end effector **214** with adjustable jaw geometries to better accommodate tissue folds (or other targets) having a wider range of sizes. For example, as shown by the illustrations in FIGS. 9D-E, the end effector **214** embodiment having the upright slot **232** (shown in FIG. 9E) is able to accommodate a comparably-sized target located at the vertex between the upper jaw **222** and lower jaw **220** without having to be opened as widely as is necessary with the end effector **214** embodiment that does not have the upright slot (shown in FIG. 9D). In addition, the vertex between the upper jaw **222** and lower jaw **220** in the embodiments having the upright slot **232** does not become a pinch point.

Those skilled in the art will recognize that the slotted jaw construction described above and shown in FIGS. 9C and 9E is adaptable for use in other laparoscopic instruments (or other instruments) having a pair of jaws oriented to grasp, trap, or engage tissue or other materials between the jaws. For example, the slotted jaw construction may be adapted for use with a laparoscopic stapling device in order to provide improved orientation between an upper staple cartridge and a lower anvil portion of the device. Other uses of the slotted jaw construction are also possible.

A launch tube **228** extends from the handle **216**, through the tubular body **212**, and distally from the end of the tubular body **212** where a distal end of the launch tube **228** is pivotally connected to the upper jaw member **222** at a launch tube pivot **230**. A distal portion of the launch tube **228** may be pivoted into position within a channel or groove defined in the upper jaw member **222**, to facilitate a low-profile configuration of the tissue manipulation end effector **214**. When articulated, either via the launch tube **228** or other mechanism, the jaw members **220**, **222** are urged into an open configuration to receive tissue in the opening between the jaw members **220**, **222**.

The launch tube **228** may be advanced from its proximal end at the handle **216** such that the portion of the launch tube **228** that extends distally from the tubular body **212** is forced to rotate at a hinge or pivot **230** and reconfigure itself such that the exposed portion forms a curved or arcuate shape that positions the launch tube opening perpendicularly relative to the upper jaw member **222**. The launch tube **228**, or at least the exposed portion of the launch tube **228**, may be fabricated from a highly flexible material or it may be fabricated, e.g., from Nitinol tubing material which is adapted to flex, e.g., via circumferential slots, to permit bending.

In the embodiment of the tissue manipulation assembly **210** shown in FIG. 6, the tubular body **212** is substantially straight and is not articulatable. In other embodiments, such as those shown in FIGS. 10A-C, the tubular body **212** includes a substantially straight portion **212a** extending from the handle **216** and a curved portion **212b** on the distal region near the tissue manipulation end effector **214**. The length, amount of curvature, and other aspects of the size, shape, and orientation of the curved portion **212b** may depend upon the types of procedures to be performed. In some embodiments, the curved portion **212b** creates an offset angle between the longitudinal axis of the proximal section **212a** of the tubular body and the longitudinal axis of the distal region of the tubular body **212** and the end effector **214** of from about 5° to about 90°. In other embodiments, the offset angle is from about 20° to about 70°. In still other embodiments, the offset angle is from about 30° to about 60°. And in still other embodiments, the offset angle is about 45°.

In some embodiments, the curved portion **212b** is formed from a material having a stiffness sufficient to maintain a shape during use by a surgeon or other user during a tissue manipulation procedure, but compliant enough to be manually straightened and inserted through a trocar. In this way, the user is able to manually straighten the instrument while inserting it through a straight, rigid trocar, after which the instrument would then spontaneously form into its shaped configuration. For example, in some embodiments, at least the curved portion **212b** of the tubular body **212** is formed from a molded or heat set plastic or polymeric material having suitable hardness and/or flexibility. The curved portion **212b** may include a curve in a selected plane relative to the plane of the end effector **214**. For example, in an embodiment, the curved portion **212b** of the distal region of the tubular body **212** is curved in the same plane as the plane of operation of the end effector **214**. In other embodiments, the curved portion **212b** of the distal region of the tubular body **212** is curved in a plane that is perpendicular to (or otherwise offset from) the plane of operation of the end effector **214**.

In still other embodiments, the tubular body **212** includes a substantially straight portion **212a** extending from the handle **216** and a steering section **212b** on the distal region near the tissue manipulation end effector **214**. Steering may be provided by one or more steering wires (push wires or pull wires), steering rods, or other suitable mechanisms that cause

a steering section to be articulated in one or more planes relative to the plane of operation of the end effector **214** and/or relative to the region of the tubular body **212a** located proximal to the steering section. The foregoing curved section or steering section **212b** of the tubular body **212** may be provided in order to better provide the surgeon or other user with the capability of moving the distal end effector **214** to a preferred location relative to the target tissue of the patient.

Turning to FIG. **10C**, some embodiments of the tissue manipulation assembly **210** include a flexible portion **228a** of the launch/drive tube **228** that is located at the curved section or steering section **212b** of the tubular body **212**. The portions of the launch/drive tube **228** located proximally of the flexible portion **228a** and housed within the rigid portion **212a** of the tubular body **212** are typically formed of a rigid material, such as a stainless steel hypotube or other material. In order to translate through the curved section or steering section **212b** of the tubular body **212**, the flexible portion **228a** of the launch tube is formed of a material having sufficient flexibility to be driven distally and withdrawn proximally around the curved portion **212b** as the launch/drive tube **228** is translated through the tubular body **212** during actuation of the tissue manipulation end effector **214**.

Turning next to FIGS. **11A-C**, some embodiments of the tissue manipulation assembly **210** include a spring-loaded variable spacer **240** that is located in-line with the launch/drive tube **228** within the tubular body **212**. The variable spacer **240** is positioned at a location between the handle **216** and the distal end effector **214**, and preferably proximal of the curved section or steering section **212b** of the tubular body **212**. The variable spacer **240** includes a first collar or distal collar **241** that is attached to or formed integrally with a distal portion **228b** of the launch/drive tube to provide a distal shoulder for a compression spring **242** that is mounted coaxially over the launch/drive tube **228**. A second collar **243** is attached to or formed integrally with the proximal end of the distal portion **228b** of the launch/drive tube and defines a proximally-directed opening into the lumen defined by the launch/drive tube. A third collar or proximal collar **244** is attached to or formed integrally on the distal end of a proximal portion **228a** of the launch/drive tube and is, in turn, attached to a piston sleeve **245** that has an inner diameter sufficient to allow the second collar **243** to slide therein, as shown in FIG. **11C**. A fourth collar or sliding collar **246** is attached to a distal end of the piston sleeve **245** and is slidably retained on the external surface of the distal portion **228b** of the launch/drive tube. The compression spring **242** is thereby retained between the distal collar **241** and the sliding collar **246** in the manner illustrated in FIG. **11C**.

Accordingly, the distal portion **228b** of the launch/drive tube is able to translate within the tubular body **212** relative to the proximal portion **228a** of the launch tube/drive tube in a telescoping manner over a distance defined by the space between the distal collar **241** and the second collar **243**. The compression spring **242** provides a force biasing the distal portion **228b** and proximal portion **228a** of the launch/drive tube apart. As described elsewhere herein, the distal end effector **214** is actuated by applying a compressive force on the launch/drive tube **228**. The spring-loaded variable spacer **240** therefore provides a mechanism that prevents the launch/drive tube **228** from being over-compressed when, for example, the jaws **220**, **222** of the end effector engage a large object (such as a large portion of tissue). Such over-compression could potentially cause damage to the launch tube **228** or other portions of the device.

Next, with reference to FIGS. **12A-G**, some embodiments of the tissue manipulation assembly **210** include a distal end

effector rotation mechanism **250** that is configured to rotate the distal end effector **214** relative to the tubular body **212**. In the embodiment shown, the rotation mechanism **250** includes a housing or shield **251** that is attached to or formed integrally with the tubular body **212** and that includes one or more openings or access ports **252** that provide access to the user to an interior space defined by the shield **251**. Located within the interior space defined by the shield **251** is a knob **253** that is attached to or formed integrally with the launch/drive tube **228**, which is slidably disposed within the tubular body **212**. Accordingly, by rotating the knob **253** around its longitudinal axis (which corresponds with the longitudinal axis of the launch/drive tube **228**), the user is able to impart rotational movement to the launch/drive tube **228** relative to the tubular body **212**. In addition, the knob **253** is able to advance (in the distal direction) or retract (in the proximal direction) within the interior space defined by the shield **251** by virtue of the fact that the knob **253** is attached to or formed integrally with the launch/drive tube **228**. Accordingly, as the user actuates the handle **216** to cause the launch/drive tube **228** to advance and retract relative to the tubular body **212**, the knob **253** is advanced and retracted within the interior space provided by the shield **251**. (Compare, e.g., the proximal position of the knob **253** in FIG. **12B** to the distal position of the knob **253** in FIG. **12C**).

In the embodiment shown in FIGS. **12A-C**, the distal end effector **214** (which is coupled to the launch tube **228**) is rotatably supported on the distal end of the tubular body **212**. Accordingly, rotating the launch/drive tube **228** relative to the tubular body **212**—via rotating the knob **253** relative to the shield **251**—causes the distal end effector **214** to rotate relative to the tubular body **212**. An embodiment of a suitable rotatable connection between the distal end effector **214** and the tubular body **212** is shown in FIGS. **12D-G**. The rotatable connection embodiment shown includes a rotatable sleeve **254** that is inserted into the proximal end of the manifold **219**, as shown in FIGS. **12E-F**. The rotatable sleeve **254** includes a distal flange **254a** that has an outer diameter that is slightly smaller than the inner diameter of the manifold **219**, thereby allowing the rotatable sleeve **254** to rotate freely relative to the manifold **219**. A collar **255** is then placed over the rotatable sleeve **254** and is attached to (such as by welding or otherwise bonding) the inner surface of the manifold **219**, creating an annular space within the manifold **219** that rotatably traps the distal flange **254a** of the rotatable sleeve **254**. (See FIG. **12G**). The tubular body **212** is then attached to the outer surface **254b** of the rotatable sleeve, thereby providing the rotatable connection shown in FIG. **12D**. Those skilled in the art will recognize that other rotatable connection mechanisms may be suitable for providing the rotatable connection between the distal end effector **214** and the tubular body **212**.

Turning back to FIGS. **3-5**, once the tissue has been engaged between the jaw members **220**, **222** of the tissue manipulation assembly **210**, a needle deployment assembly **260** is urged through the handle **216**, through the tubular body **212**, and out through the launch tube **228**. Embodiments of the needle deployment assembly are shown in FIGS. **3-5**, and are described in substantial detail in U.S. patent application Ser. Nos. **10/955,245**, **11/070,863**, and **12/486,578**, which are hereby incorporated by reference in their entirety (including all references cited therein) as if fully set forth herein. The needle deployment assembly **260** may pass through the lower jaw member **220** via a needle assembly opening (not shown in the drawings) defined in the lower jaw member **220** to pierce through the grasped tissue. Once the needle deployment assembly has been passed through the engaged tissue, one or more tissue anchors **50a** of a tissue anchor assembly **100** (see

FIG. 13) are deployed for securing the tissue, as described in further detail herein and in U.S. patent application Ser. No. 10/955,245, which has been incorporated by reference above.

Referring to FIGS. 3-5, each shows additional details relating to embodiments of a needle deployment assembly 260. As mentioned above, a needle deployment assembly 260 may be deployed through the tissue manipulation assembly 210 by introducing the needle deployment assembly 260 into the handle 216 and through the tubular body 212 such that the needle deployment assembly 260 is advanced from the launch tube 228 and into or through grasped tissue. Once the needle deployment assembly 260 has been advanced through the tissue, the anchor assembly 100 may be deployed or ejected. The anchor assembly 100 is normally positioned within the distal portion of a tubular sheath 264 that extends from a needle assembly control or housing 262. Once the anchor assembly 100 has been fully deployed from the sheath 264, the spent needle deployment assembly 260 may be removed from the tissue manipulation assembly 210 and another needle deployment assembly may be introduced without having to remove the tissue manipulation assembly 210 from the patient. The length of the sheath 264 is such that it may be passed entirely through the length of the tubular body 212 to enable the deployment of the needle deployment assembly 260 into and/or through the tissue.

The elongate sheath or catheter 264 extends removably from the needle assembly control or housing 262. The sheath or catheter 264 and the housing 262 may be interconnected via an interlock 270 which may be adapted to allow for the securement as well as the rapid release of the sheath 264 from the housing 262 through any number of fastening methods, e.g., threaded connection, press-fit, releasable pin, etc. The needle body 272, which may be configured into any one of the variations described above, extends from the distal end of the sheath 264 while maintaining communication between the lumen of the sheath 264 and the needle opening 274.

An elongate pusher 276 comprises a flexible wire, coil, or hypotube that is translationally disposed within the sheath 264 and movably connected within the housing 262. A proximally-located actuation member 278 is rotatably or otherwise connected to the housing 262 to selectively actuate the translational movement of the elongate pusher 276 relative to the sheath 264 for deploying the anchors from the needle opening 274. The tissue anchor assembly 100 is positioned distally of the elongate pusher 276 within the sheath 264 for deployment from the sheath 264. Needle assembly guides 280 protrude from the housing 262 for guidance through the locking mechanism described above.

Turning to FIGS. 14A-D and 15A-F, in some embodiments, the needle deployment assembly 260 provided in the tissue anchor delivery device 208 with an anchor retention mechanism that facilitates deployment of a single anchor of a tissue anchor assembly 100 without inadvertently deploying both anchors of the assembly. FIGS. 14A-D and 15A-F illustrate the distal portion of a sheath 264 and needle body 272 of a needle deployment assembly 260. The remaining portions of the delivery device 208 have been omitted only for clarity.

In the embodiment shown in FIG. 14A, the elongate pusher 276 is provided with an extension arm 277 having an enlarged portion at its distal end. The enlarged portion of the extension arm 277 traps a first knot 62a formed at a proximal end of the suture of the tissue anchor assembly 100 within the interior space of the sheath 264. A second knot 62b formed distally of the first knot 62a is attached (e.g., with glue or other adhesive) to the distal anchor 50a, thereby providing the pusher 276—to which the extension arm 277 is attached—with the capability of positively controlling the position of the distal anchor

50a within the sheath 264. Accordingly, as the pusher 276 is advanced distally within the sheath 264, the distal anchor 50a (and the components that are within the sheath 264 distal of the distal anchor) will be advanced distally. As the pusher 276 is retracted proximally within the sheath 264, the distal anchor 50a will be retracted proximally. This capability reduces the possibility that the distal anchor 50a will be deployed inadvertently.

The embodiment shown in FIG. 14B is similar to the one shown in FIG. 14A, except rather than having the distal anchor 50a being adhered to the second knot 62b, the distal anchor 50a is prevented from moving distally relative to the suture 60 by the inclusion of a step up in thickness of the suture relative to the diameter of the passageway through the distal anchor 50a. For example, the suture has a first thickness at region 60a that is small enough that the distal anchor 50a is able to slide freely back and forth along the suture 60a. However, at region 60b, the suture has a thickness that is larger, such that the distal anchor 50b is not able to traverse the transition from region 60a to region 60b. In this way, the distal anchor 50a is thereby trapped within a pre-determined region of travel by the elongate pusher 276, thereby reducing the possibility that the distal anchor 50a will be deployed inadvertently.

In the embodiments shown in FIGS. 14C and 14D, the extension arm 277 includes a region that physically traps the entire distal anchor 50a, thereby directly controlling the location of the distal anchor with the pusher 276.

Turning to FIGS. 15A-F, the manner of operation of the retention mechanisms described above is shown. A needle 272 and sheath 264 of a needle deployment assembly 260 are deployed from a tissue anchor deployment device 208. As the pusher 276 is advanced, the cinch 102 and suture 60 are expelled from the distal end of the needle body 272, as shown in FIG. 15B. Further advancement of the pusher 276 causes the proximal anchor 50b to be expelled. (See FIG. 15C). In FIG. 15C, the enlarged distal end of the extension arm 277 is seen extending from the distal opening of the needle body 272, but the distal anchor 50a remains held within the sheath 264. As the deployment device 208 is retracted, such as when the device is moved to the location of a second tissue fold, the suture 60 is paid out, as shown in FIG. 15D. Finally, the pusher 276 is fully extended outside of the sheath 264 and needle body 272, thereby releasing the distal anchor 50a. (See FIG. 15E). In an alternative embodiment, the extension arm 277 is provided with a shape memory curve, (see FIG. 15F), to prevent inadvertent engagement or interference with the target tissue.

After the tissue anchor assembly 100 is deployed using any of the deployment devices and embodiments described herein, the locking mechanism 102 of the tissue anchor assembly 100 may be advanced uni-directionally over the suture 60 to thereby secure a region of tissue between the pair of tissue anchors 50a, 50b. In some embodiments, the locking mechanism 102 is advanced using a grasper, knot pusher, or other suitable instrument. For example, in some embodiments, a cinch tool is adapted to grasp the suture 60 and to apply a force that advances the locking mechanism 102 over the suture 60. Several cinch tool embodiments are described in U.S. patent application Ser. No. 10/954,665, filed Sep. 29, 2004, and in U.S. Pat. No. 7,390,329, each of which is incorporated by reference in its entirety.

The laparoscopic tissue anchor delivery device 208 is typically used in conjunction with one or more additional laparoscopic instruments to perform the tissue reconfiguration procedures described herein. Several conventional laparoscopic instruments are known to those having ordinary skill in the

art, and the details of those instruments are beyond the scope of the present description. FIG. 16 is an exemplary illustration of a laparoscopic instrument 310 having a shaft 312, an end effector 314, and a handle 316. In the embodiment shown, the instrument includes a substantially rigid shaft 312 and an end effector 314 in the form of a grasper having a pair of grasping jaws 320, 322. In FIGS. 17A-D, several alternative end effector embodiments are shown, including an alternative pair of grasping jaws 330, 332 shown in FIG. 17A, a pair of alligator grasper jaws 340, 342 shown in FIG. 17B, a pair of tong-style grasping members 350, 352 shown in FIG. 17C, and a blunt obturator 360 shown in FIG. 17D. Other optional laparoscopic instruments are suitable for use, including Babcock-style graspers, Maryland-style graspers, and other devices known to those skilled in the art.

FIG. 18 illustrates a conventional trocar 400, including a cannula head portion 410 and a cannula tube portion 412. In some embodiments, the cannula tube portion 412 is flexible to facilitate additional ranges of motion for the laparoscopic instruments used to perform the described procedures. The procedures described herein make use of known trocars 400 and the specific type of trocar 400 to be used by a surgeon may be left to the personal preference of the surgeon.

#### Laparoscopic Hernia Repair

Novel procedures for repairing a patient's incisional or other type of hernia will be described. The procedures overcome many of the disadvantages associated with prior art methods by providing a hernia repair that is easy to perform, has a low recurrence rate, has a minimal peri-operative morbidity, and is cost effective. The methods are performed laparoscopically and include deployment of one or more tissue anchor assemblies or other tissue fasteners that facilitate approximation of the opposed edges of a hernia defect. For clarity, the disclosure below will include a description of methods for repairing an incisional hernia. It should be understood that the described methods are also applicable to the repair of other types of hernia, unless otherwise stated.

Turning to FIG. 19, the procedure includes placing the patient 500 in a supine position, which is typical in abdominal surgery. In order to determine the location of the hernia opening inside the abdomen 501, a conventional cut-down method is used to enter the abdominal cavity at a site away from the hernia. The initial incision 502 of the cut-down method is no more than 10-12 mm. This initial incision allows for the placement of a blunt trocar 400 through the incision and into the peritoneal cavity. With the trocar in place, the abdomen is insufflated with 15 mm Hg pressure of carbon dioxide gas. A laparoscope is then introduced through the trocar 400 to inspect the interior of the abdomen and the abdominal wall. If the inspection reveals any evidence of adhesions near the hernia site which are required to be lysed or dissolved, or of incarceration or confinement of tissues, which needs to be reduced, additional 5-10 mm trocars 400 and laparoscopic working instruments 310 are introduced into the abdomen 501 under direct vision for this purpose.

As shown in FIG. 20, a hernia is a hole 510 in the fascia 512 of the abdominal wall and allows the inner lining of the abdominal wall to protrude or bulge. The bulge forms a balloon-like sac (hernia sac) beneath the skin 514 and fat layers 516 beneath the skin. Intra-abdominal contents such as fat or loops of intestine can also protrude through the defect 510 in the fascia 512 and into the hernia sac. Loops of intestine or fat can become trapped (incarcerated) or twisted (strangulated) in the hernia sac and block the flow of food in the intestinal tract or compromise its blood supply. Although this is very

rare, strangulation may lead to a potentially life threatening and serious problem requiring emergency surgery. Hernias occur in the abdominal wall where the fascia 512 is compromised, most commonly in the groin (inguinal hernias), and areas of previous surgical incisions (ventral hernias). Hernias tend to grow larger over time and can become symptomatic.

In a conventional laparoscopic hernia repair, shown in FIG. 21, a surgical mesh 520 is applied over a weakened area or defect 510 in the abdominal wall. The mesh 520 is sewn to the area or attached with fasteners such as tacks 522, bridging the hole 510 or weakened area beneath it. As the area heals, the mesh 520 becomes firmly integrated into the inner abdominal wall membrane (peritoneum) that protects the organs of the abdomen. One disadvantage of the conventional procedure is that the separated portions of the fascia 512 are not brought together, with the result that the defect 510 remains in place after the procedure is completed. As a result, the mesh 520, along with the intra-abdominal fat, loops of intestine, and other contents are still able to protrude through the defect 510.

In several embodiments of the procedures described herein, the portions of the fascia 512 that are separated by the occurrence of the hernia are brought together by deploying one or more tissue anchor assemblies 100 or other types of tissue fasteners across the defect 510. The first and second anchors 50a, 50b of the tissue anchor assemblies 100 are then approximated and secured, thereby approximating the separated edges of the fascia 512 and reducing or eliminating the hernia defect 510. In other embodiments, the separated edges of the fascia 512 are approximated prior to deploying the tissue anchor assemblies 100 or other types of tissue fasteners. A surgical mesh 520 is then attached to the fascia 512 over the approximated defect 510. In other embodiments, the tissue anchor assemblies 100 or other types of fasteners are sufficient to repair the hernia defect without the use of a surgical mesh 520, and the mesh 520 is therefore not attached to the fascia 512. Exemplary embodiments of the methods are described more fully below, with reference to FIGS. 22 through 27A-D.

As shown in FIG. 22, a tissue manipulation end effector 214 of a tissue anchor deployment device is inserted through a trocar and into the peritoneal space, and is brought into the vicinity of the hernia defect 510 and, more particularly, into the vicinity of the edges of the fascia 512 surrounding the hernia defect 510. As described more fully above, the exemplary tissue anchor deployment device described herein includes a needle deployment assembly 260, the distal end of which is translatably located within the launch tube 228 portion of the tissue anchor deployment device.

The jaws 220, 222 of the tissue manipulation end effector 214 are used to grasp a first one of the edges of the fascia 512a surrounding the hernia defect 510. In some embodiments, the first edge of the fascia 512a and/or other tissue associated with the hernia defect is separated from adjacent or surrounding tissue using a component separation technique known to those skilled in the art. In the embodiments in which a component separation technique is included, the separation of the fascia 512a from other associated tissue and/or tissue layers facilitates manipulation of the tissue by reducing the amount of tension required to approximate the opposed edges of tissue at the hernia defect. This result, in turn, allows the surgeon or other user to manipulate and/or approximate the tissue more easily, such that the procedure is simplified and the defect is repaired more readily. Moreover, in some embodiments, another laparoscopic instrument 310, such as a laparoscopic grasper, is used to facilitate grasping of the first fascia edge 512a by the end effector 214.

After the first fascia edge **512a** is engaged, the second anchor **50b** (or other fastener) and cinch **102** (or other locking mechanism) are then deployed from the device via the needle deployment assembly **260** through the grasped region of the fascia **512a**, as shown in FIG. **23**. In the embodiment shown, the first fascia edge **512a** is grasped by the jaws **220**, **222** of the end effector **214** such that the second anchor **50b** and cinch **102** are deployed on the peritoneal side of the first fascia edge **512a**. The first fascia edge **512** is then released, and the end effector **214** is repositioned to grasp a second of the edges of the fascia **512b** located substantially opposite to the first fascia edge **512a** across the hernia defect **510**. The suture **60** of the tissue anchor assembly **100** extends out of the needle deployment assembly **260** located within the launch tube **228** of the device, through the first fascia edge **512**, and through the second tissue anchor **50b**. As shown in FIG. **24**, the needle deployment assembly **260** is then advanced through the second fascia edge **512b**, where the first tissue anchor **50a** is deployed. In the embodiment shown, the second fascia edge **512b** is grasped by the jaws **220**, **222** of the end effector **214** such that the first anchor **50a** is also deployed on the peritoneal side of the second fascia edge **512b**.

In several embodiments, a plurality of additional tissue anchor assemblies **100** are deployed adjacent to one another along the length of the hernia defect **510**. Turning to FIG. **25A**, after the first and second tissue anchors **50a**, **50b** of each of the plurality of tissue anchor assemblies **100** have been deployed through the first fascia edge **512a** and second fascia edge **512b**, the uni-directional cinch **102** of each tissue anchor assembly **100** is advanced over the suture **60** to thereby cause the tissue anchors **50a**, **50b** to be approximated and to cause the first fascia edge **512a** to be brought into proximity to the second fascia edge **512b** in a side-by-side orientation. In an alternative embodiment, shown in FIG. **25B**, the second tissue anchors **50b** are deployed through the second fascia edge **512b** in the opposite direction to that shown in FIG. **21**, i.e., such that the second tissue anchor **50b** is located on the side of the fascia opposite to the peritoneal cavity. The uni-directional cinch **102** of each tissue anchor assembly **100** is advanced over the suture **60** to thereby cause the tissue anchors **50a**, **50b** to be approximated and to cause the first fascia edge **512a** to be brought into proximity to the second fascia edge **512b** in an overlapping orientation.

In some embodiments, the plurality of tissue anchor assemblies **100** provide sufficient holding strength to maintain the first and second fascia edges **512a**, **512b** in proximity to one another permanently, thereby repairing the hernia defect **510**. In other embodiments, the plurality of tissue anchor assemblies **100** provide sufficient holding strength to maintain the first and second fascia edges **512a**, **512b** in proximity to one another for a time sufficient to promote healing between the secured fascia edges, thereby repairing the hernia defect **510**. In still other embodiments, the first and second fascia edges **512a**, **512b** are oversewn with a suture or other suitable member in the manner described below in relation to FIG. **27D** in order to further secure the approximated fascia edges in proximity to one another.

Turning to FIG. **26**, after approximating the first fascia edge **512a** and second fascia edge **512b**, an optional surgical mesh **520** is applied to the abdominal tissue such that the mesh **520** fully or substantially covers the reduced or eliminated defect **510**. Advantageously, a smaller surgical mesh **520** will be needed in the typical procedure after the fascia edges **512a**, **512b** in the vicinity of the hernia defect **510** have been approximated than would otherwise be needed without the tissue approximation. As a result, the surgical mesh **520** may be more easily deployed, heals better and more readily,

and is less likely to pucker or to become displaced after deployment. As discussed above, some embodiments of the repair methods described herein do not include application of the surgical mesh. The surgical mesh patch **520** is well known in the art. It is constructed of a mesh material which allows bodily tissue growth into the mesh to further stabilize the position of the mesh patch **520** at some point subsequent to surgery. The mesh patch **520** is known to be constructed of many different materials, including but not limited to, Gore-Tex® fabric, polytetrafluoroethylene, or polypropylene. The procedures described herein make use of known mesh patches **520** and the specific type, size, and other properties of the mesh patch **520** to be used by a surgeon may be left to the personal preference of the surgeon.

The surgical mesh **520** is secured to the internal surface of the fascia **512** using suture or other fasteners, such as surgical tacks **522**, in a manner known to those skilled in the art. In the embodiment shown in FIG. **26**, the first and second fascia edges **512a**, **512b** are approximated by a plurality of tissue anchor assemblies **100** in an overlapping orientation, as described above in relation to FIG. **25B**. The overlapping orientation provides a “ridge” along the reduced or eliminated defect **510** that has a lower profile than the ridge provided by the side-by-side orientation described above in relation to FIG. **25A**. The lower profile size of the ridge allows the mesh **520** to more readily engage the underlying fascia **512**, thereby promoting faster and more complete ingrowth of tissue throughout the extent of the surgical mesh **520**.

FIGS. **27A-D** show a plurality of four tissue anchor assemblies **100** deployed through fascia tissue **512** on opposed sides of a hernia defect **510**. The view shown in the illustration provided by FIGS. **27A-D** is that which would be provided by a laparoscope viewing the hernia defect **510** from inside the peritoneal space during the repair procedure. Each of the tissue anchor assemblies **100** includes first and second tissue anchors **50a**, **50b** attached to each other by a suture **60**, and having a uni-directional cinch **102** slidable on the suture **60** outside the second tissue anchor **50b**. The span of the suture **60** is sufficient to extend across the widest portion of the hernia defect prior to approximation. In some embodiments, the suture span is at least about 15 cm. In other embodiments, the suture span is at least about 10 cm. In still other embodiments, the suture span is at least about 5 cm. In FIG. **27A**, each of the four tissue anchor assemblies **100** has been deployed across the defect **510** without approximating the respective first and second tissue anchors **50a**, **50b**. In some embodiments, each of the tissue anchor assemblies **100** is partially approximated, as shown in FIG. **27B**, in order to partially approximate the fascia edges **512a**, **512b**. In an embodiment, the tissue anchor assemblies **100** are partially approximated one at a time beginning at one end of the defect **510** and working toward the other end of the defect **510**, such that the approximating forces may be substantially evenly distributed between each of the tissue anchor assemblies **100**. The partial approximation of each of the tissue anchor assemblies **100** is repeated until all of the tissue anchor assemblies **100** are approximated by the desired amount, such as the substantially fully approximated orientation shown in FIG. **27C**.

In the embodiments shown in FIGS. **27A-C**, the tissue anchor assemblies **100** include sutures **60** aligned in parallel adjacent to one another. In other embodiments, the tissue anchors **50a**, **50b** of one or more of the tissue anchor assemblies **100** are deployed such that the sutures **60** cross over one another. The alignment of the sutures **60** of the tissue anchor assemblies **100** is generally at the discretion of the surgeon or other user.

As discussed above, in some embodiments, a suture **530** is used to oversee the approximated defect **510**, as shown in FIG. **27D**. In the embodiment shown in FIG. **27D**, a running stitch of suture **530** is used to oversee the approximated defect **510**. (Note that the oversee stitches are not shown over the tissue anchors **50a**, **50b** for clarity). Those skilled in the art will recognize that other suturing methods may be used to provide the oversee support, as desired.

Turning next to FIGS. **28A-E**, another embodiment of a laparoscopic hernia repair method is shown. As shown in FIG. **28A**, a tissue manipulation end effector **214** of a tissue anchor deployment device having a curved or steerable distal region is inserted through a trocar and into the peritoneal space, and is brought into the vicinity of the hernia defect **510** and, more particularly, into the vicinity of the edges of the fascia **512a**, **512b** surrounding the hernia defect **510**. As described more fully above, the exemplary tissue anchor deployment device described herein includes a needle deployment assembly **260**, the distal end of which is translationally located within the launch tube **228** portion of the tissue anchor deployment device. In the embodiment shown, the jaws **220**, **222** of the tissue manipulation end effector **214** are used to grasp a second one of the edges of the fascia **512b** surrounding the hernia defect **510**. After the second fascia edge **512b** is engaged, the second anchor **50b** (or other fastener) and cinch **102** (or other locking mechanism) are then deployed from the device via the needle deployment assembly **260** through the grasped region of the fascia **512b**, as shown in FIG. **28B**. In the embodiment shown, the second fascia edge **512a** is grasped by the jaws **220**, **222** of the end effector **214** such that the second anchor **50b** and cinch **102** are deployed on the peritoneal side of the second fascia edge **512b**. With proper positioning of the laparoscope, the needle **272** of the needle deployment assembly **260** is deployed under full visualization of the needle **272** as it advances from the distal end of the launch tube **228**, through the fascia edge **512b**, and into the space of the peritoneal cavity.

The second fascia edge **512b** is then released, and the end effector **214** is repositioned to grasp a first of the edges of the fascia **512a** located substantially opposite to the second fascia edge **512b** across the hernia defect **510**. Advantageously, because of the curved distal region **212b** and/or the steerability of the distal region **212b** of the tubular body **212**, the orientation of the distal end effector **214** relative to the tubular body **212** of the device is such that the device need only be advanced distally, where it is in position to engage the first fascia edge **512a**. The suture **60** of the tissue anchor assembly **100** extends out of the needle deployment assembly **260** located within the launch tube **228** of the device, through the first fascia edge **512a**, and through the second tissue anchor **50b**. As shown in FIG. **28C**, the needle deployment assembly **260** is then advanced through the first fascia edge **512a**, where the first tissue anchor **50a** is deployed. In the embodiment shown, the first fascia edge **512a** is grasped by the jaws **220**, **222** of the end effector **214** such that the first anchor **50a** is deployed on the abdominal side of the first fascia edge **512a**.

Turning next to FIG. **28D**, the anchor assembly **100** is then released from the deployment device **208**, leaving the anchor assembly **100** spanning the hernia defect **510**. The cinch **102** (or other locking mechanism) is then advanced over the suture **60** in order to approximate the distal and proximal anchors **50a**, **50b**, thereby approximating the edges of the fascia **512a**, **512b** in the overlapping orientation shown in FIG. **28E**. As discussed above, in several embodiments, a plurality of additional tissue anchor assemblies **100** are deployed adjacent to one another along the length of the hernia defect **510**. Turning to FIG. **25A**, after the first and

second tissue anchors **50a**, **50b** of each of the plurality of tissue anchor assemblies **100** have been deployed through the first fascia edge **512a** and second fascia edge **512b**, the unidirectional cinch **102** of each tissue anchor assembly **100** is advanced over the suture **60** to thereby cause the tissue anchors **50a**, **50b** to be approximated and to cause the first fascia edge **512a** to be brought into proximity to the second fascia edge **512b**.

Another alternative embodiment of a laparoscopic hernia repair method is shown in FIGS. **29A-E**. In the alternative method, a surgical mesh **520** is first placed over the hernia defect **510** in the manner shown in FIG. **29A**. Once the surgical mesh **520** is in place, a tissue anchor deployment device is advanced into the vicinity of the hernia defect **510**, as shown in FIG. **29B**. A first tissue fold is then formed in tissue, such as at one edge of the fascia **512b** surrounding the hernia defect, and a first tissue anchor assembly **100** is deployed through the tissue fold and through at least a portion of the surgical mesh **520**. (See FIG. **29C**). In this manner, the surgical mesh **520** is attached to the tissue fold and/or the tissue surrounding the hernia defect **510** via the tissue anchor assembly **100**. Next, a second tissue fold is formed in the tissue, such as the tissue on or near another edge of the fascia **512a**, and a second tissue anchor assembly **100** is deployed through the second tissue fold and through the surgical mesh **520**, as shown in FIG. **29D**. In some embodiments, the tissue anchor assemblies **100** are attached such that a tension force is maintained through the surgical mesh **520** to thereby partially or fully approximate the fascia edges **512a**, **512b**, thereby partially or fully closing the hernia defect **510**. In other embodiments, the tissue anchor assemblies **100** are attached without creating a tension force carried by the surgical mesh **520**, in which case the tissue anchor assemblies **100** serve to secure the surgical mesh **520** to the tissue. Additional tissue anchor assemblies **100** may be deployed in a similar manner as determined by the surgeon or other clinician. The tissue anchor assemblies **100** thereby secure the surgical mesh **520** to the tissue surrounding the hernia defect in a manner such that the surgical mesh **520** substantially or completely covers the hernia defect. (See FIG. **29E**).

Turning to FIGS. **30A-E**, still another alternative embodiment of a laparoscopic hernia repair method is shown. In the embodiment shown, a modified tissue manipulation device **210** is provided having only an upper jaw member **222**, which may be attached to the tubular body **212** via a manifold **219**. (See FIG. **30A**). The modified device **210** is actuated by applying a distally-directed force upon the launch/drive tube **228** via the handle **216**, which causes the distal region of the launch tube **228** to form the arcuate shape shown in FIG. **30A**. This creates a passage for deploying a tissue anchor assembly **100** or other fastener via a needle deployment assembly **260**. Accordingly, as shown in FIG. **30B**, the distal end effector **214** of the modified device is brought into the vicinity of a fascia edge **512b** surrounding a hernia defect **510**. A first tissue anchor **50a** is deployed by the modified device **210** through a surgical mesh **520** and either through or, as shown in FIG. **30B**, into the fascia tissue **512b**. The needle assembly **260** is then retracted from the tissue and the surgical mesh **520** and the second tissue anchor **50b** and locking mechanism **102** of the tissue anchor assembly **100** are deployed and secured. (See FIGS. **30C** and **30D**). The tissue anchor assembly **100** thus deployed secures the surgical mesh **520** to the fascia tissue **512b**. One or more additional tissue anchor assemblies are then optionally deployed at additional locations of fascia tissue **512a** surrounding the hernia defect **510**, further securing the mesh **520** to the tissue. In the embodiment shown, the

surgical mesh 520 is thereby secured to the fascia tissue and substantially or completely covers the hernia defect 510.

The described methods include several embodiments, including all of the embodiments described herein as well as all combinations of each of those embodiments. Additional combinations of the therapeutic methods described herein will obtain similar results. In addition, other versions of the foregoing methods have been contemplated and are within the scope of the present methods. For example, the devices and methods may be incorporated into methods for repairing tissue defects and/or approximating regions of tissue in open surgical procedures, endolumenal surgical procedures, and other surgical or diagnostic procedures. As a specific example, the devices and methods may be used to approximate opposed regions of tissue in the vicinity of a hernia defect in an open surgical procedure.

Although various illustrative embodiments are described above, it will be evident to one skilled in the art that various changes and modifications are within the scope of the invention. It is intended in the appended claims to cover all such changes and modifications that fall within the true spirit and scope of the invention.

What is claimed is:

1. A method for laparoscopically repairing a hernia defect in a patient, comprising:

grasping a first region of tissue on a first side of the hernia defect with a laparoscopic tool;  
 piercing through the grasped first region of tissue with a needle;  
 deploying a first tissue anchor from the needle;  
 withdrawing the needle from the first region of tissue;  
 grasping a second region of tissue on a second side of the hernia defect with the laparoscopic tool;  
 piercing through the grasped second region of tissue with the needle;  
 deploying a second tissue anchor from the needle, with the second tissue anchor connected to the first tissue anchor via a suture;  
 withdrawing the needle from the second region of tissue;  
 tensioning the suture and moving the first and second tissue anchors towards each other to draw the first and second regions of tissue towards each other; and  
 sliding a locking mechanism along the suture to prevent the tissue anchors from moving away from each other.

2. The method of claim 1 further comprising deploying a plurality of additional tissue anchors into or through the first and second regions of tissue.

3. The method of claim 1 wherein said second tissue anchor is located on the suture between the first tissue anchor and the locking mechanism, and wherein the locking mechanism and second tissue anchor are slidably retained on the suture.

4. The method of claim 3 wherein the locking mechanism comprises a cinch that is slidable on the suture in only a single direction.

5. The method of claim 1 further comprising moving the first and second tissue anchors towards each other by pulling on the suture and pushing the second anchor towards the first anchor.

6. The method of claim 1 further comprising applying a surgical mesh over the first and second regions of tissue and securing the surgical mesh to the tissue.

7. The method of claim 1 further including positioning surgical mesh over the hernia defect and with the piercing steps including piercing through the surgical mesh.

8. A method for laparoscopically repairing a hernia defect in a patient, comprising:

grasping a first region of tissue on a first side of the hernia defect with a first laparoscopic tool;  
 piercing through the grasped first region of tissue with a needle;  
 deploying a first tissue anchor from the needle;  
 withdrawing the needle from the first region of tissue;  
 grasping a second region of tissue on a second side of the hernia defect with a second laparoscopic tool;  
 piercing through the grasped second region of tissue with the needle;  
 deploying a second tissue anchor from the needle, with the second tissue anchor connected to the first tissue anchor via a suture;  
 withdrawing the needle from the second region of tissue;  
 tensioning the suture and moving the first and second tissue anchors towards each other to draw the first and second regions of tissue towards each other; and  
 sliding a locking mechanism along the suture to prevent the tissue anchors from moving away from each other.

9. The method of claim 8 further including positioning surgical mesh over the hernia defect and with the piercing steps including piercing through the surgical mesh.

10. A method for laparoscopically repairing a hernia defect in a patient, comprising:

grasping a first region of tissue on a first side of the hernia defect;  
 piercing through the grasped first region of tissue with a needle;  
 deploying a first tissue anchor from the needle;  
 withdrawing the needle from the first region of tissue;  
 grasping a second region of tissue on a second side of the hernia defect;  
 piercing through the grasped second region of tissue with the needle;  
 deploying a second tissue anchor from the needle, with the second tissue anchor connected to the first tissue anchor via a suture;  
 withdrawing the needle from the second region of tissue;  
 tensioning the suture and moving the first and second tissue anchors towards each other to draw the first and second regions of tissue towards each other; and  
 sliding a locking mechanism along the suture to prevent the tissue anchors from moving away from each other.

11. The method of claim 10 further including positioning surgical mesh over the hernia defect and with the piercing steps including piercing through the surgical mesh.

\* \* \* \* \*

专利名称(译)	腹腔镜疝修补术的装置和方法		
公开(公告)号	<a href="#">US8777965</a>	公开(公告)日	2014-07-15
申请号	US13/103936	申请日	2011-05-09
[标]申请(专利权)人(译)	陈EUGENE慕 MAAHS TRACYD EWERS RICHARDÇ SWANSTROM LEE大号		
申请(专利权)人(译)	陈EUGENE G. MAAHS TRACY D. EWERS RICHARD C. SWANSTROM LEE L.		
当前申请(专利权)人(译)	USGI MEDICAL , INC.		
[标]发明人	CHEN EUGENE G MAAHS TRACY D EWERS RICHARD C SWANSTROM LEE L		
发明人	CHEN, EUGENE G. MAAHS, TRACY D. EWERS, RICHARD C. SWANSTROM, LEE L.		
IPC分类号	A61B17/04 A61B17/00		
CPC分类号	A61B17/0401 A61B17/0057 A61B17/0469 A61B17/0487 A61B2017/00575 A61B2017/00637 A61B2017/00818 A61B2017/00867 A61B2017/0409 A61B2017/0419 A61B2017/0462 A61B2017/0464 A61B2017/06052		
代理机构(译)	博钦律师事务所		
优先权	61/476129 2011-04-15 US		
其他公开文献	US20120265218A1		
外部链接	<a href="#">Espacenet</a> <a href="#">USPTO</a>		

摘要(译)

描述了用于腹腔镜修复疝气的装置和方法。在一些实施例中，腹腔镜器械用于将一个或多个组织锚固组件部署到围绕或邻近疝缺损的筋膜组织的边缘中。组织锚固组件用于使筋膜组织接近，以便于修复过程，改善愈合，并减少复发的发生率。

