



US008747302B2

(12) **United States Patent**  
**Piskun**

(10) **Patent No.:** **US 8,747,302 B2**  
(45) **Date of Patent:** **Jun. 10, 2014**

- (54) **LAPAROSCOPIC INSTRUMENT AND TROCAR SYSTEM AND RELATED SURGICAL METHOD**
- (71) Applicant: **Covidien LP**, Mansfield, MA (US)
- (72) Inventor: **Gregory Piskun**, Morganville, NJ (US)
- (73) Assignee: **Covidien LP**, Mansfield, MA (US)
- (\* ) Notice: Subject to any disclaimer, the term of this patent is extended or adjusted under 35 U.S.C. 154(b) by 0 days.

4,112,932 A	9/1978	Chiulli
4,644,951 A	2/1987	Bays
4,863,430 A	9/1989	Klyce et al.
4,863,438 A	9/1989	Gauderer et al.
5,026,366 A	6/1991	Leckrone
5,159,921 A	11/1992	Hoover
5,183,471 A	2/1993	Wilk
5,241,968 A	9/1993	Slater
5,242,409 A	9/1993	Buelna
5,258,006 A	11/1993	Rydell et al.
5,269,772 A	12/1993	Wilk
5,312,391 A	5/1994	Wilk
5,330,486 A	7/1994	Wilk
5,334,143 A	8/1994	Carroll
5,366,478 A	11/1994	Brinkerhoff et al.
5,375,588 A	12/1994	Yoon
5,383,852 A	1/1995	Stevens-Wright
5,391,156 A	2/1995	Hildwein et al.

- (21) Appl. No.: **13/862,832**
- (22) Filed: **Apr. 15, 2013**

(Continued)

- (65) **Prior Publication Data**  
US 2013/0289576 A1 Oct. 31, 2013

**FOREIGN PATENT DOCUMENTS**

EP	0567146 A2	10/1993
EP	0592244 A2	4/1994

**Related U.S. Application Data**

(Continued)

- (60) Division of application No. 12/957,879, filed on Dec. 1, 2010, now Pat. No. 8,439,831, which is a continuation of application No. 10/668,542, filed on Sep. 23, 2003, now Pat. No. 7,850,600.

**OTHER PUBLICATIONS**

International Search Report for PCT/US05/24636 dated Jun. 20, 2006. (2 pages).

- (51) **Int. Cl.**  
*A61B 1/04* (2006.01)

(Continued)

- (52) **U.S. Cl.**  
USPC ..... 600/114; 600/115; 600/204; 600/206; 600/208

Primary Examiner — Matthew J Kasztejna

- (58) **Field of Classification Search**  
USPC ..... 600/114–115, 204–208; 604/164.01–164.13, 264  
See application file for complete search history.

(57) **ABSTRACT**

Laparoscopic instruments and cannulas are provided for performing laparoscopic procedures entirely through the umbilicus. Generally S-shaped laparoscopic instruments placed through the C-shaped trocar sleeves or through the cannula and instrument holder unit provide markedly improved degrees of instruments' freedom during trans-umbilical laparoscopic procedures.

- (56) **References Cited**  
U.S. PATENT DOCUMENTS

2,669,991 A	2/1954	Curutchet
4,016,884 A	4/1977	Kwan-Gett

**8 Claims, 7 Drawing Sheets**

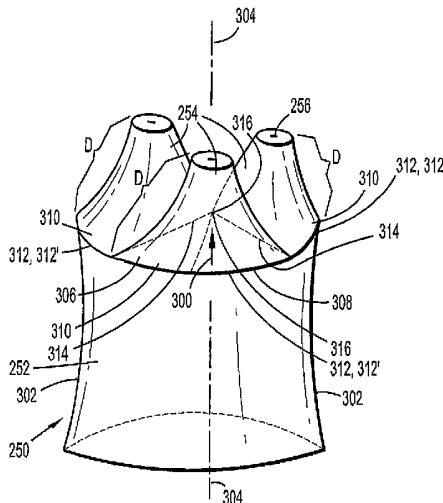

(56)

## References Cited

## U.S. PATENT DOCUMENTS

5,395,327 A 3/1995 Lundquist et al.  
 5,395,367 A 3/1995 Wilk  
 5,441,483 A 8/1995 Avitall  
 5,467,763 A 11/1995 McMahan et al.  
 5,480,410 A 1/1996 Cuschieri et al.  
 5,490,843 A 2/1996 Hildwein et al.  
 5,522,791 A 6/1996 Leyva  
 5,540,648 A 7/1996 Yoon  
 5,545,179 A 8/1996 Williamson, IV  
 5,549,563 A 8/1996 Kronner  
 5,549,637 A 8/1996 Crainich  
 5,571,115 A 11/1996 Nicholas  
 5,571,137 A 11/1996 Marlow et al.  
 5,575,799 A 11/1996 Bolanos et al.  
 5,578,048 A 11/1996 Pasqualucci et al.  
 5,603,723 A 2/1997 Aranyi et al.  
 5,607,437 A 3/1997 Simon et al.  
 5,634,911 A 6/1997 Hermann et al.  
 5,634,937 A 6/1997 Mollenauer et al.  
 5,651,771 A 7/1997 Tangherlini et al.  
 5,653,705 A 8/1997 de la Torre et al.  
 5,662,662 A 9/1997 Bishop et al.  
 5,672,168 A 9/1997 de la Torre et al.  
 5,683,378 A 11/1997 Christy  
 5,725,536 A 3/1998 Oberlin et al.  
 5,735,791 A 4/1998 Alexander, Jr. et al.  
 5,782,859 A 7/1998 Nicholas et al.  
 5,803,921 A 9/1998 Bonadio  
 5,810,721 A 9/1998 Mueller et al.  
 5,830,191 A 11/1998 Hildwein et al.  
 5,836,871 A 11/1998 Wallace et al.  
 5,857,461 A 1/1999 Levitsky et al.  
 5,860,995 A 1/1999 Berkelaar  
 5,871,474 A 2/1999 Hermann et al.  
 5,904,703 A 5/1999 Gilson  
 5,906,577 A 5/1999 Beane et al.  
 5,916,147 A 6/1999 Boury  
 5,916,198 A 6/1999 Dillow  
 5,931,832 A 8/1999 Jensen  
 5,957,913 A 9/1999 de la Torre et al.  
 5,964,781 A 10/1999 Mollenauer et al.  
 5,997,515 A 12/1999 de la Torre et al.  
 6,018,094 A 1/2000 Fox  
 6,024,736 A 2/2000 de la Torre et al.  
 6,033,378 A 3/2000 Lundquist et al.  
 6,033,426 A 3/2000 Kaji  
 6,042,573 A 3/2000 Lucey  
 6,077,288 A 6/2000 Shimomura et al.  
 6,086,603 A 7/2000 Termin et al.  
 6,099,506 A 8/2000 Macoviak et al.  
 6,142,936 A 11/2000 Beane et al.  
 6,217,555 B1 4/2001 Hart et al.  
 6,217,590 B1 4/2001 Levinson  
 6,238,373 B1 5/2001 de la Torre et al.  
 6,264,604 B1 7/2001 Kieturakis et al.  
 6,315,770 B1 11/2001 de la Torre et al.  
 6,319,246 B1 11/2001 de la Torre et al.  
 6,440,061 B1 8/2002 Wenner et al.  
 6,440,063 B1 8/2002 Beane et al.  
 6,447,489 B1 9/2002 Peterson  
 6,454,783 B1 9/2002 Piskun  
 6,464,686 B1 10/2002 O'Hara et al.  
 6,468,292 B1 10/2002 Mollenauer et al.  
 6,488,620 B1 12/2002 Segermark et al.  
 6,488,692 B1 12/2002 Spence et al.  
 6,537,209 B1 3/2003 Pinkhasik et al.  
 6,551,270 B1 4/2003 Bimbo et al.  
 6,558,371 B2 5/2003 Dorn  
 6,578,577 B2 6/2003 Bonadio et al.  
 6,582,364 B2 6/2003 Butler et al.  
 6,623,426 B2 9/2003 Bonadio et al.  
 6,669,674 B1 12/2003 Macoviak et al.  
 6,676,639 B1 1/2004 Ternstrom  
 6,706,050 B1 3/2004 Giannadakis  
 6,800,084 B2 10/2004 Davison et al.

6,811,532 B2 11/2004 Ogura et al.  
 6,846,287 B2 1/2005 Bonadio et al.  
 6,878,110 B2 4/2005 Yang et al.  
 6,890,295 B2 5/2005 Michels et al.  
 6,899,673 B2 5/2005 Ogura et al.  
 6,916,331 B2 7/2005 Mollenauer et al.  
 6,945,932 B1 9/2005 Caldwell et al.  
 6,972,026 B1 12/2005 Caldwell et al.  
 7,001,397 B2 2/2006 Davison et al.  
 7,008,377 B2 3/2006 Beane et al.  
 7,056,321 B2 6/2006 Pagliuca et al.  
 7,081,089 B2 7/2006 Bonadio et al.  
 7,195,590 B2 3/2007 Butler et al.  
 7,214,185 B1 5/2007 Rosney et al.  
 7,223,257 B2 5/2007 Shubayev et al.  
 7,223,278 B2 5/2007 Davison et al.  
 7,235,084 B2 6/2007 Skakoon et al.  
 7,238,154 B2 7/2007 Ewers et al.  
 7,276,075 B1 10/2007 Callas et al.  
 7,300,399 B2 11/2007 Bonadio et al.  
 7,316,699 B2 1/2008 McFarlane  
 8,439,831 B2 5/2013 Piskun  
 2002/0038077 A1 3/2002 de la Torre et al.  
 2002/0183594 A1 12/2002 Beane et al.  
 2003/0014076 A1 1/2003 Mollenauer et al.  
 2003/0036748 A1 2/2003 Cooper et al.  
 2003/0114832 A1 6/2003 Kohler et al.  
 2003/0135091 A1 7/2003 Nakazawa et al.  
 2003/0208122 A1 11/2003 Melkent et al.  
 2003/0236549 A1 12/2003 Bonadio et al.  
 2004/0049099 A1 3/2004 Ewers et al.  
 2004/0167543 A1 8/2004 Mazzocchi et al.  
 2005/0241647 A1 11/2005 Nguyen et al.  
 2005/0288558 A1 12/2005 Ewers et al.  
 2006/0020241 A1 1/2006 Piskun et al.  
 2006/0041188 A1 2/2006 Dirusso et al.  
 2006/0149306 A1 7/2006 Hart et al.  
 2006/0241651 A1 10/2006 Wilk  
 2006/0247498 A1 11/2006 Bonadio et al.  
 2007/0203398 A1 8/2007 Bonadio et al.  
 2007/0208312 A1 9/2007 Norton et al.  
 2007/0276430 A1 11/2007 Lee et al.  
 2008/0027476 A1 1/2008 Piskun  
 2008/0200767 A1 8/2008 Ewers et al.  
 2008/0255519 A1 10/2008 Piskun et al.  
 2009/0012477 A1 1/2009 Norton et al.

## FOREIGN PATENT DOCUMENTS

EP 1312318 A1 5/2003  
 EP 1637086 A1 3/2006  
 EP 1870043 A2 12/2007  
 EP 2044889 A1 4/2009  
 WO WO-93/14801 8/1993  
 WO WO-94/04067 3/1994  
 WO WO-97/42889 11/1997  
 WO WO-99/16368 4/1999  
 WO WO-02/07611 1/2002  
 WO WO-2006/019723 2/2006  
 WO WO-2006/100658 A2 9/2006  
 WO WO-2006/113216 A2 10/2006  
 WO WO-2008/015566 A2 2/2008  
 WO WO-2008/121294 A1 10/2008

## OTHER PUBLICATIONS

International Search Report of PCT/US08/03991 dated Jul. 30, 2008. (1 page).  
 European Search Report of EP 09252160 dated Mar. 17, 2010 (2 pages).  
 European Search Report for EP 09252168 dated Mar. 19, 2010 (3 pages).  
 International Preliminary Report on Patentability for PCT/US2008/003991 dated Oct. 6, 2009 (7 pages).  
 Notification of the Recording of a Change for PCT/US2008/003991 dated Mar. 23, 2010 (1 page).  
 Written opinion of the International Searching Authority for PCT/US2008/03991 dated Jul. 30, 2008 (6 pages).

(56)

**References Cited**

OTHER PUBLICATIONS

International Preliminary Report on Patentability for PCT/US2005/024636 dated Jan. 23, 2007. (1 page).

Written Opinion of the International Searching Authority for PCT/US2005/024636 dated Sep. 5, 2006 (5 pages).

International Search Report for PCT/US05/24636 dated Sep. 5, 2006 (3 pages).

International Search Report for PCT/US05/24111 dated Aug. 24, 2006 (2 pages).

Written Opinion of the International Searching Authority for PCT/US2005/024111 dated Aug. 24, 2006. (3 pages).

International Preliminary Report on Patentability for PCT/US2005/024111 dated Jan. 23, 2007 (4 pages).

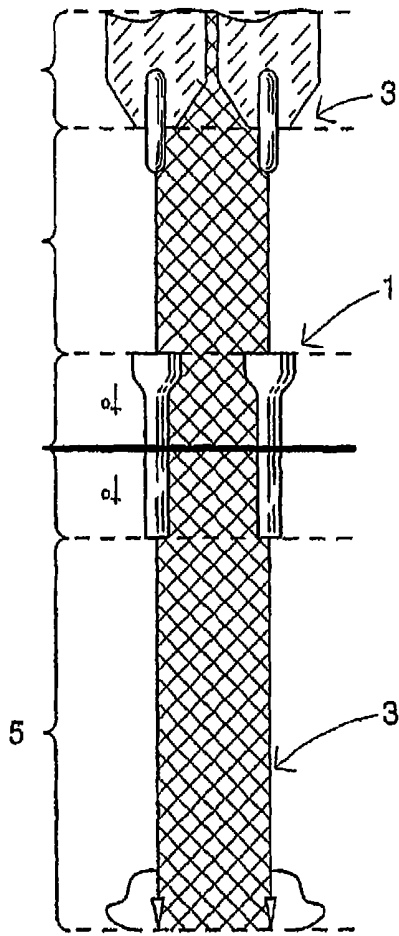

FIG. 1  
PRIOR ART

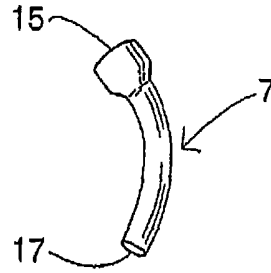

FIG. 2A



FIG. 2B

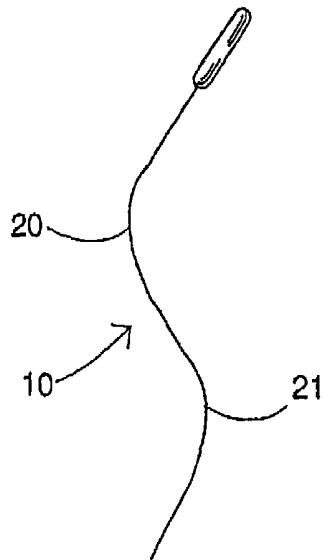

FIG. 2C

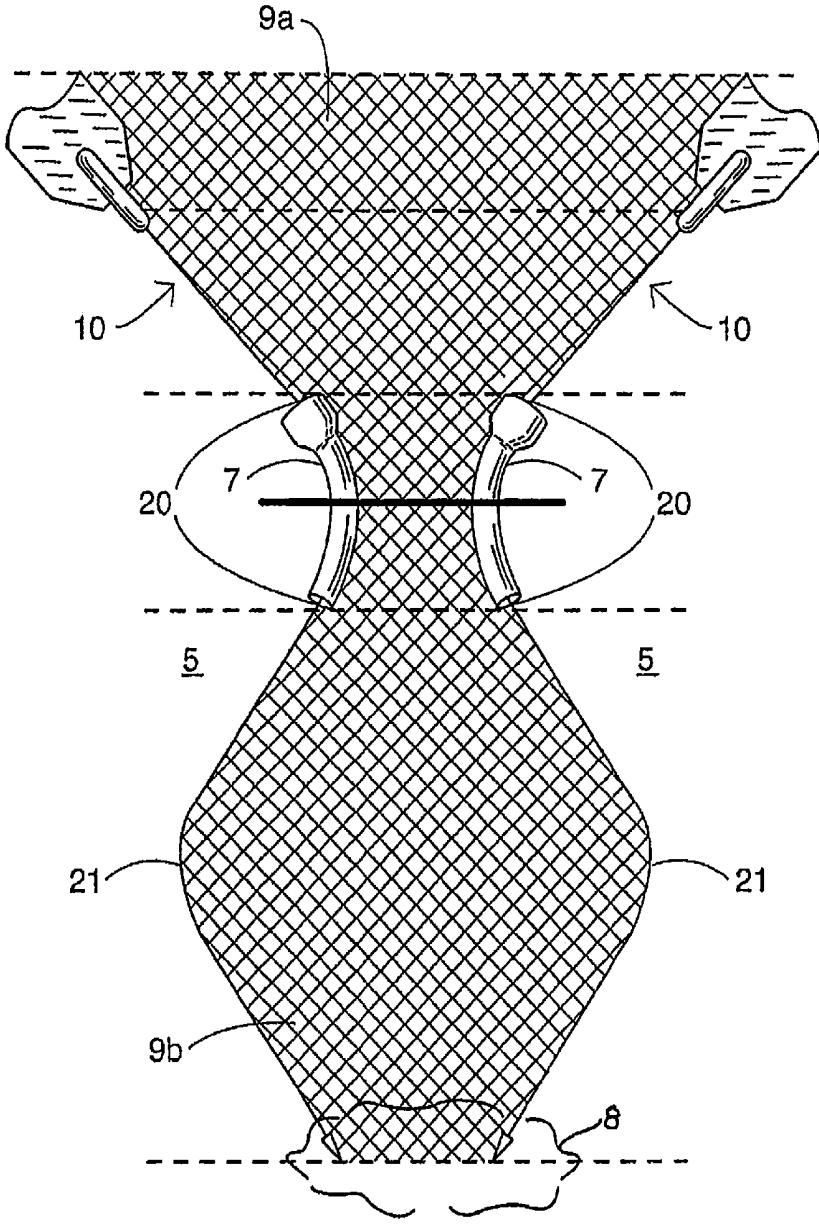

FIG. 3

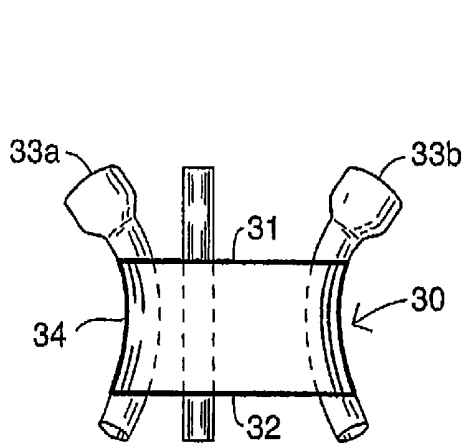

FIG. 4A

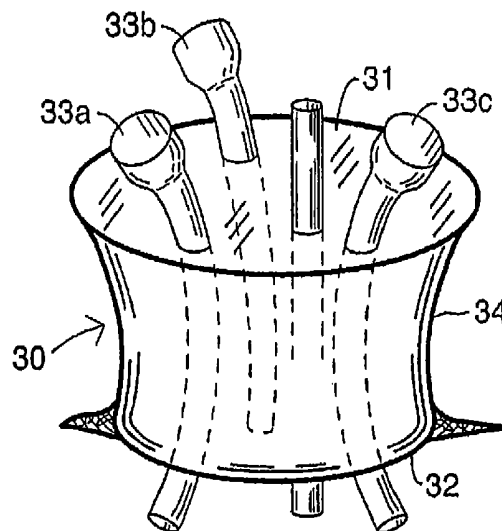

FIG. 4B

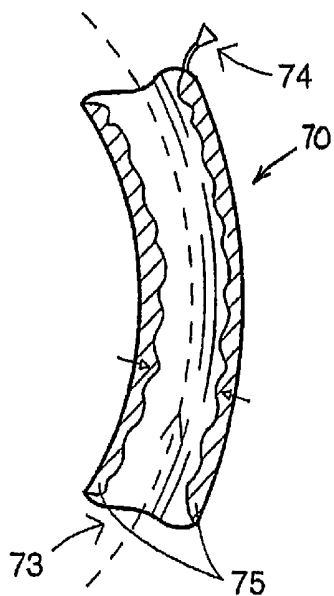

FIG. 5A

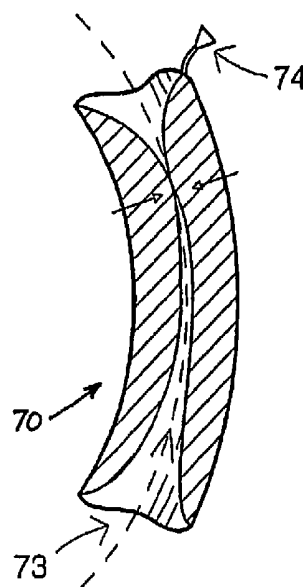

FIG. 5B

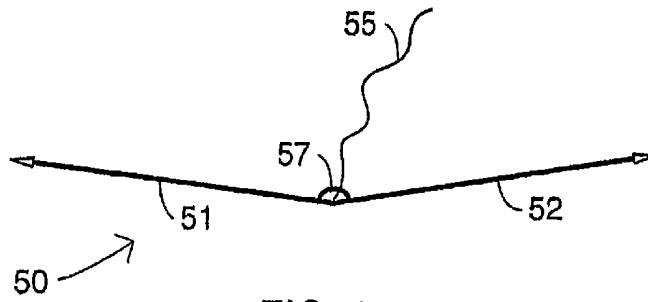

FIG. 6

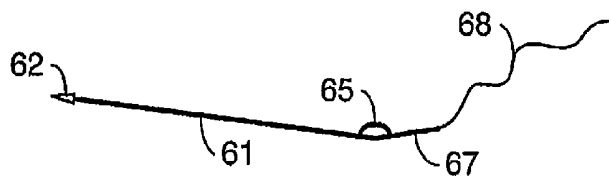

FIG. 7

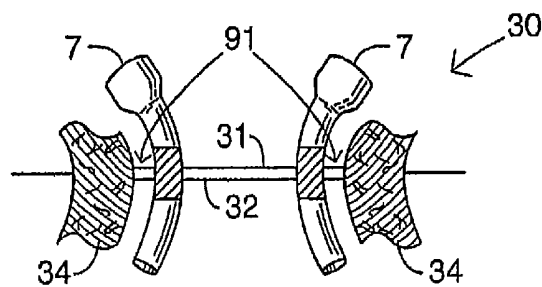

FIG. 8

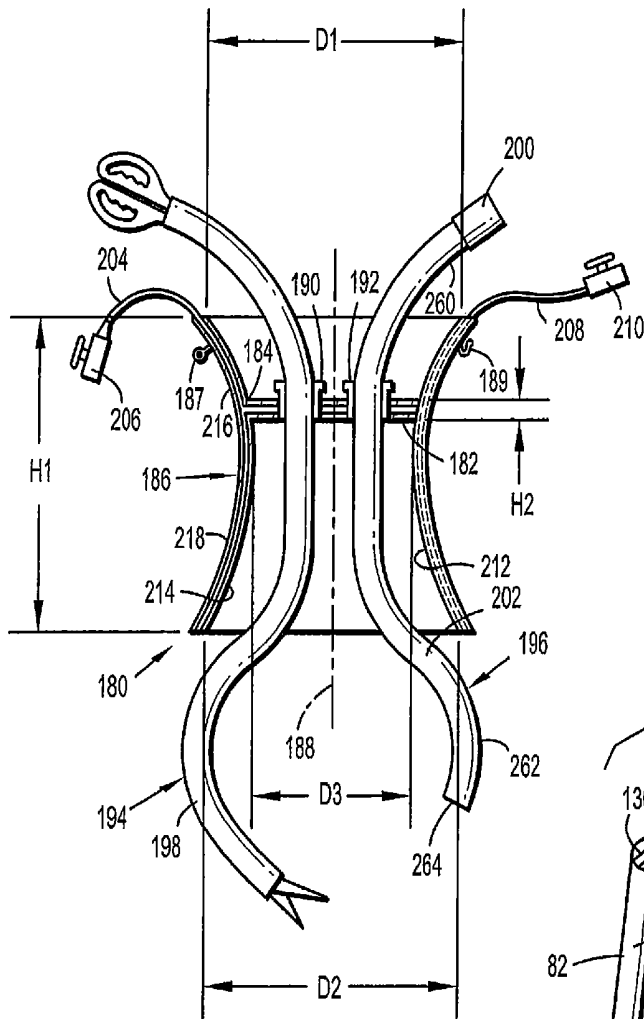

FIG. 12

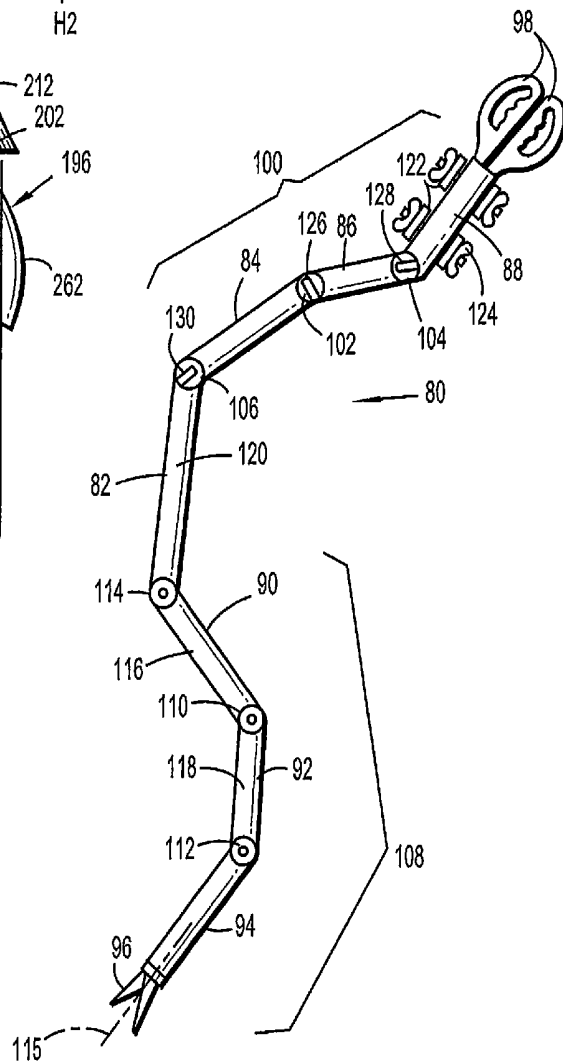

FIG. 9

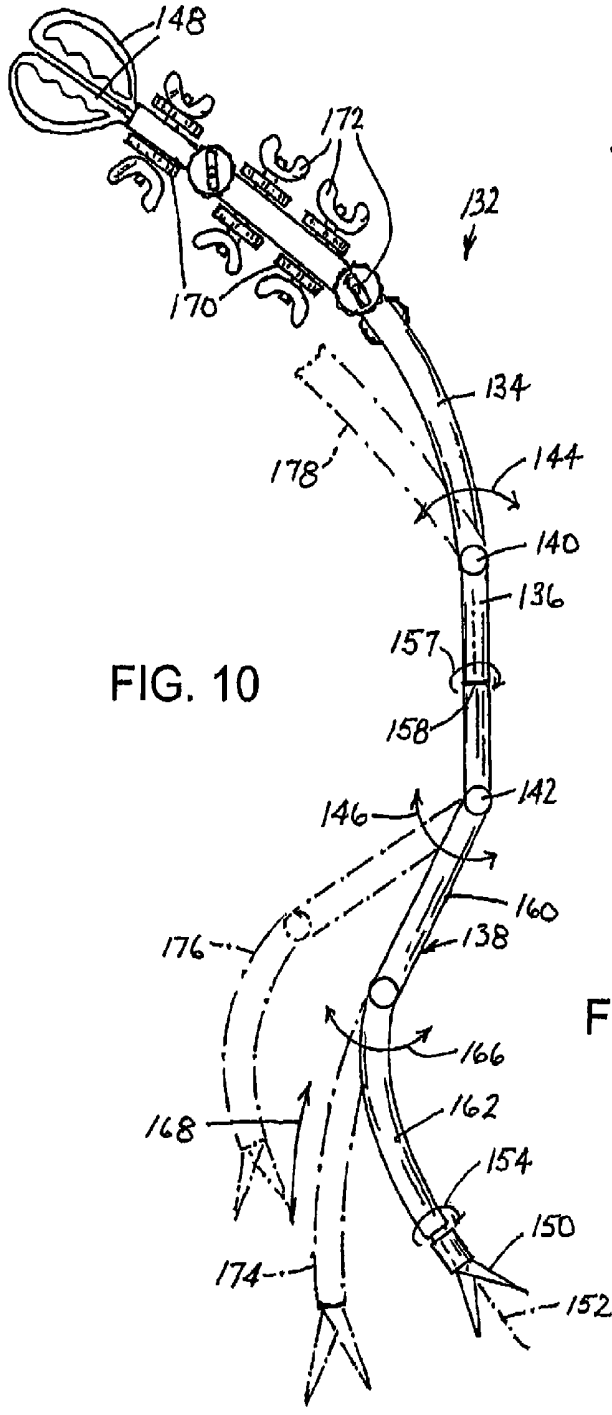

FIG. 10

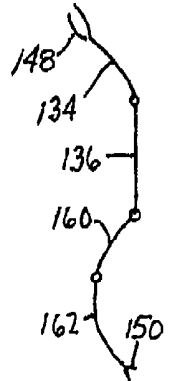

FIG. 11A

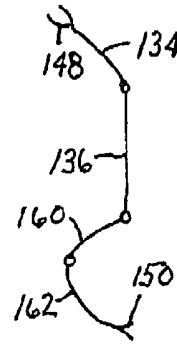

FIG. 11B

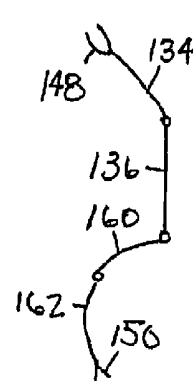

FIG. 11C



FIG. 11D

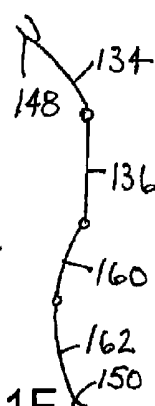

FIG. 11E

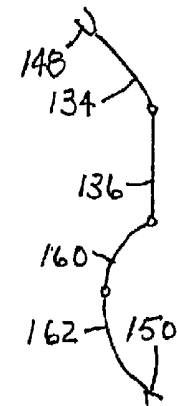

FIG. 11F

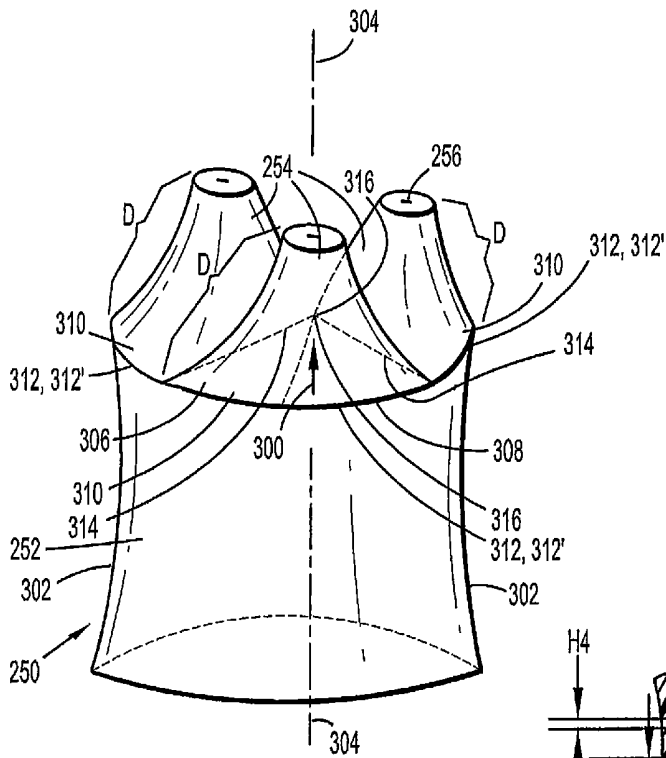

FIG. 16

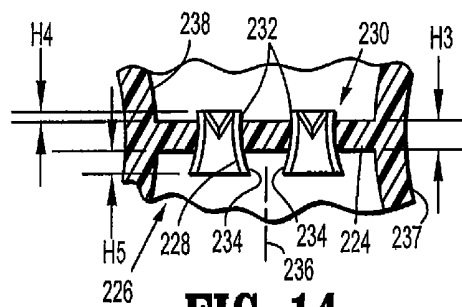

FIG. 14

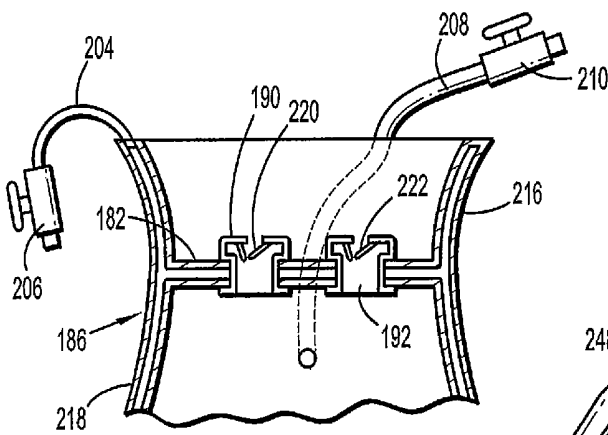

FIG. 13

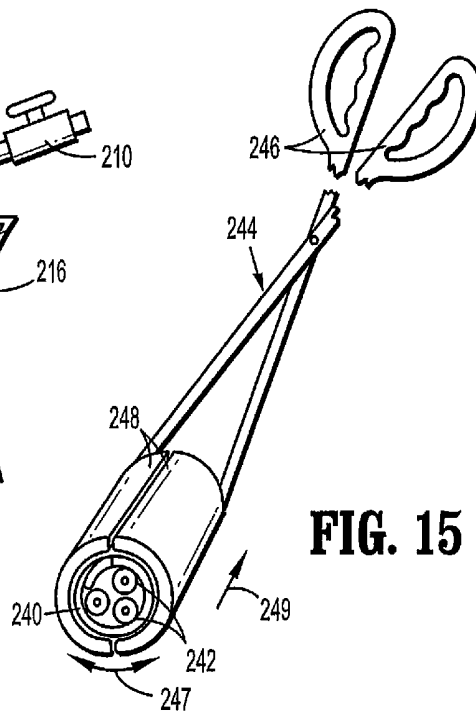

FIG. 15

# LAPAROSCOPIC INSTRUMENT AND TROCAR SYSTEM AND RELATED SURGICAL METHOD

## CROSS-REFERENCE TO RELATED APPLICATIONS

This application is a divisional of U.S. patent application Ser. No. 12/957,879 filed on Dec. 1, 2010 by Piskun, entitled "LAPAROSCOPIC INSTRUMENT AND TROCAR SYSTEM AND RELATED SURGICAL METHOD", published as U.S. Patent Application Publication No. US 2012/0022334 A1 on Jan. 26, 2012, now U.S. Pat. No. 8,439,831, which is a continuation of U.S. patent application Ser. No. 10/668,542 filed on Sep. 23, 2003 by Piskun, entitled "LAPAROSCOPIC INSTRUMENT AND TROCAR SYSTEM AND RELATED SURGICAL METHOD", now U.S. Pat. No. 7,850,600, the entire contents of each of which are incorporated by reference herein.

## FIELD OF INVENTION

The present invention relates to the surgical instruments, and particularly to laparoscopic instruments, which facilitate the performance of laparoscopic procedures entirely through the umbilicus.

## BACKGROUND

Abdominal laparoscopic surgery gained popularity in the late 1980's, when benefits of laparoscopic removal of the gallbladder over traditional (open) operation became evident. Reduced postoperative recovery time, markedly decreased post-operative pain and wound infection, and improved cosmetic outcome are well established benefits of laparoscopic surgery to perform an operation utilizing smaller incisions of the body cavity wall.

Laparoscopic procedures generally involve insufflation of the abdominal cavity with CO<sub>2</sub> gas to a pressure of around 15 mm Hg. The abdominal wall is pierced and a 5-10 mm in diameter straight tubular cannula or trocar sleeve is then inserted into the abdominal cavity. A laparoscopic telescope connected to an operating room monitor is used to visualize the operative field, and is placed through (one of the trocar sleeve(s). Laparoscopic instruments (graspers, dissectors, scissors, refractors, etc.) are placed through two or more additional trocar sleeves for the manipulations by the surgeon and surgical assistant(s).

Recently, so called "mini-laparoscopy" has been introduced utilizing 2-3 mm diameter straight trocar sleeves and laparoscopic instruments. When successful, mini-laparoscopy allows further reduction of abdominal wall trauma and improved cosmesis. However, instruments used for mini-laparoscopic procedures are generally more expensive and fragile. Because of their performance limitations, due to their smaller diameter (weak suction-irrigation system, poor durability, decreased video quality), mini-laparoscopic instruments can generally be used only on selected patients with favorable anatomy (thin cavity wall, few adhesions, minimal inflammation, etc.). These patients represent a small percentage of patients requiring laparoscopic procedures. In addition, smaller, 2-3 mm, incisions may still cause undesirable cosmetic outcomes and wound complications (bleeding, infection, pain, keloid formation, etc.).

Since the benefits of smaller and fewer body cavity incisions are proven, it would be attractive to perform an operation utilizing only a single incision in the navel. An umbilicus

is the thinnest and least vascularized, and a well-hidden, area of the abdominal wall. The umbilicus is generally a preferred choice of abdominal cavity entry in laparoscopic procedures. An umbilical incision can be easily enlarged (in order to eviscerate a larger specimen) without significantly compromising cosmesis and without increasing the chances of wound complications. The placement of two or more standard (straight) cannulas and laparoscopic instruments in the umbilicus, next to each other, creates a so-called "chopstick" effect, which describes interference between the surgeon's hands, between the surgeon's hands and the instruments, and between the instruments. This interference greatly reduces the surgeon's ability to perform a described procedure.

Thus, there is a need for instruments and trocar systems which allow laparoscopic procedures to be performed entirely through the umbilicus, while at the same time reducing or eliminating the "chopstick effect". A laparoscopic procedure performed entirely through the umbilicus, using the laparoscopic instruments and trocar system according to an embodiment of the present invention, allows one to accomplish the necessary diagnostic and therapeutic tasks while further minimizing abdominal wall trauma and improving cosmesis.

## SUMMARY OF THE INVENTION

A general object of the present invention is to provide a laparoscopic instrument and an instrument or cannula holder for use in the performance of laparoscopic procedures, for instance, entirely through the umbilicus.

A more specific object of the present invention is to provide a laparoscopic instrument, which may markedly increase the workspace between the laparoscopic; instruments and between the hands of the surgeon where more than one instrument shaft is inserted through the same opening in the patient's abdominal wall.

A more general object of the present invention is to provide a laparoscopic instrument that has enhanced operational flexibility to facilitate the performance of laparoscopic surgical procedures.

A related object of the present invention is to provide a cannula or instrument holder utilizable in combination with such a laparoscopic instrument to facilitate the performance of a laparoscopic procedure through a single opening in the patient's abdominal wall, for instance, in the patient's umbilicus.

Another object of the present invention is to provide generally S-shaped laparoscopic instruments.

In one embodiment of the present invention, a stand-alone laparoscopic medical instrument insertable through a laparoscopic trocar sleeve comprises an elongate shaft, an operative tip disposed at one end of the shaft, and an actuator disposed at an opposite end of the shaft, the actuator being operatively connected to the operative tip via the shaft for controlling the operation of the operative tip. The shaft has a proximal end portion and middle portion and a distal end portion, at least the distal end portion being independently bendable to form a C shape. The distal segments of the shaft are rotatable about a longitudinal axis at least one location along the instrument's shaft, preferably at the operative tip or proximal to the operative tip.

Pursuant to additional features of the present invention, the distal end portion of the instrument shaft is continuously bendable into a smoothly curved C-shaped configuration, while a lock is operatively connected to the shaft for releasably maintaining the C-shaped curved configuration. Moreover, the distal end portion may be provided with an articu-

lated joint, whereby the distal end portion is swingable relative to the middle portion of the shaft. The proximal end portion may also be independently bendable to form a C shape.

In a further embodiment of the present invention, a stand-alone laparoscopic medical instrument insertable through a laparoscopic trocar sleeve comprises an elongate shaft, an operative tip disposed at the one end of the shaft, and an actuator disposed at an opposite end of the shaft. The actuator is operatively connected to the operative tip via the shaft for controlling the operation of the operative tip. The shaft has a proximal end portion and a distal end portion, the distal end portion being continuously bendable to form a smoothly curved C shape. The distal end portion is connected to the proximal end portion via an articulated joint, whereby the distal end portion may be laterally swung with the reference to the proximal end portion.

In this further embodiment of the invention, the proximal end portion of the instrument shaft may include a rigid segment connected to the distal end portion via the articulated joint. The proximal end portion may additionally include a flexible segment connected to the rigid segment on a side thereof opposite the distal end portion, the actuator being connected to a free end of the flexible segment, opposite the rigid segment.

A stand-alone laparoscopic medical instrument insertable through a laparoscopic trocar sleeve comprises, in accordance with another embodiment of the present invention, an elongate shaft, an operative tip disposed at one end of the shaft, and a manual actuator disposed at an opposite end of the shaft, the manual actuator being operatively coupled to the operative tip via the shaft. A first mechanism is operatively connected to the shaft for bending a proximal portion of the shaft in a first direction, while a second mechanism is operatively connected to the shaft for bending a distal portion of the shaft in a second direction different from the first direction, whereby the shaft assumes a shape with a plurality of differently shaped segments.

The shaft has a longitudinal axis at the one end, and the instrument further comprises a rotation mechanism operatively connected to the shaft for rotating the operative tip about the axis.

Pursuant to another feature of this other embodiment of the invention, first locking element is operatively connected to the first mechanism and a second locking element is operatively connected to the second mechanism, whereby the proximal portion and the distal portion may be maintained as the differently shaped segments. Where the proximal portion and the distal portion are bendable by the first mechanism and the second mechanism in a common plane, the instrument may further comprise an additional mechanism operatively connected to the shaft for bending the distal portion of the shaft in an additional direction out of the plane.

Where the proximal portion of the shaft assumes a first C-shaped configuration in response to the operation of the first mechanism and the distal portion of the shaft assumes a second C-shaped configuration in response to operation of the second mechanism, the C-shaped configurations may face opposite sides of the shaft.

A laparoscopic medical instrument comprises, in accordance with an additional embodiment of the present invention, an elongate flexible shaft, an operative tip disposed at one end of the shaft, and a manual actuator disposed at an opposite end of the shaft, the manual actuator being operatively coupled to the operative tip via the shaft, a first bending mechanism being operatively connected to the shaft for curving a proximal portion of the shaft in a first direction, and a

second bending mechanism being operatively connected to the shaft for curving a distal portion of the shaft in a second direction different from the first direction, whereby the shaft assumes a shape with a plurality of arcuate segments.

The instrument of this additional embodiment of the invention may additionally comprise a rotation mechanism operatively connected to the shaft for rotating the operative tip about the axis, a first locking element operatively connected to the first bending mechanism and a second locking element operatively connected to the second bending mechanism. The bending mechanisms each include a manual actuator mounted to the shaft at the other end thereof.

A holder for cannulas and instruments in laparoscopic surgical operations comprises, in accordance with the present invention, a plate member having a surrounding edge and a wall surrounding the plate member, the wall being connected to the plate member all along the edge. The wall has a longitudinal axis, while the plate member extends substantially transversely to the axis. The plate member may be provided with a plurality of apertures for receiving respective elongate laparoscopic surgical members.

The height dimension of the wall of the cannula and instrument holder is at least as great as, and preferably substantially greater than, the height dimension of the plate member. The wall may have at least one end portion extending as a flange to the plate member. In at least one embodiment of the cannula and instrument holder, the wall has two end portions extending as endless flanges to the plate, with the plate member being located at one end of the wall and with the plate member and the wall forming a cup shape.

The inner diameter of the wall of the cannula and instrument holder at an end opposite the plate member is preferably larger than the inner diameter of the wall at the plate member, so that the cannula and instrument holder has a flared or tapered profile.

Pursuant to further features of the present invention, the plate member and/or the wall of the cannula and instrument holder is inflatable, while the plate member is provided at the apertures with extensions elongating the apertures. The height of the plate member, in a direction parallel to the axis of the cannula and instrument holder, is at least as great as the height of the extensions. Preferably, the plate member is flexible.

Pursuant to another feature of the present invention, where the apertures in the plate member of the cannula and instrument holder have a longitudinal dimension extending generally parallel to the axis, at least one of the apertures has a curvilinear or arced shape along the longitudinal dimension of the one of the apertures.

The wall of the cannula and instrument holder may be flexible and at least partially curved in a direction parallel to the axis of the holder.

At least one of the plate member and the wall of the cannula and instrument holder is provided with a gas channel for the introduction of insufflation gas into a patient. In addition, the wall is advantageously provided with an anchoring element for securing the holder to a patient. The anchoring element is preferably taken from the group consisting of a hook and an eyelet.

#### BRIEF DESCRIPTION OF THE DRAWINGS

FIG. 1 is a schematic view of a conventional laparoscopic instrument inserted through a conventional straight trocar sleeve or cannula.

FIG. 2A is a side view and FIG. 2B is an end view of an exemplary embodiment of a flexible C-shaped trocar sleeve or cannula. FIG. 2C is an exemplary embodiment of an S-shaped instrument.

FIG. 3 is a schematic view of an exemplary embodiment of an S-shaped laparoscopic instrument inserted through a C-shaped flexible trocar sleeve or cannula.

FIG. 4A is a lateral view and FIG. 4B is a perspective view of an exemplary inflatable unit with multiple C-shaped trocar sleeve or cannulas incorporated within the unit.

FIG. 5A is a non-inflated lateral view and FIG. 5B is an inflated lateral view of an exemplary inflatable C-shaped trocar sleeve or cannula having a balloon-like structure within the hollow body of the cannula.

FIG. 6 is a lateral view of an exemplary angulated needle with two sharp ends and a thread attached at the angle of the needle.

FIG. 7 is a lateral view of an exemplary angulated needle having a long segment with a pointed end on one side of the angle and a short segment having attached thread on the other side of the angle.

FIG. 8 is a cross-sectional view of an exemplary embodiment of an inflatable unit having multiple cannulas incorporated within the unit.

FIG. 9 is a schematic side elevational view of a laparoscopic instrument in accordance with the present invention.

FIG. 10 is a schematic side elevational view of another laparoscopic instrument in accordance with the present invention.

FIGS. 11A-11F are diagrams of the instrument of FIG. 10, showing different possible operational configurations of the instrument.

FIG. 12 is a schematic cross-sectional view of a laparoscopic instrument or cannula holder in accordance with the present invention.

FIG. 13 is a partial view similar to FIG. 12 of the laparoscopic instrument or cannula holder of that drawing figure.

FIG. 14 is a partial cross-sectional view of another laparoscopic instrument or cannula holder in accordance with the present invention.

FIG. 15 is a schematic perspective view of a laparoscopic instrument or cannula holder in a collapsed configuration between jaws of a deployment instrument.

FIG. 16 is a schematic perspective view of another laparoscopic instrument or cannula holder in accordance with the invention.

#### DETAILED DESCRIPTION

The present invention provides laparoscopic instruments and trocar sleeves or cannulas for the performance of laparoscopic procedures entirely through the umbilicus. The instruments may, however, be used to perform laparoscopic procedures at locations on a patient other than the umbilicus. Referring now in specific detail to the drawings, in which like reference numerals identify similar or identical elements, there is shown in FIG. 1 a conventional, prior art laparoscopic instrument—trocar assembly.

As illustrated in FIG. 1, a conventional trocar sleeve or cannula 1 is an essentially straight, hollow instrument, which allows conventional laparoscopic instruments 3 such as an endoscope of suitable diameter to be inserted through the conventional cannula 1 and into the abdominal cavity 5 of a patient. Conventional cannulas 1 have a diameter of around 2-15 mm. Once the conventional laparoscopic instruments 3

are in place, standard laparoscopic procedures may be performed, such as cholecystectomy, appendectomy, or simple diagnostic laparoscopy.

As shown in FIG. 1, when conventional trocar sleeves or cannulas 1 and conventional laparoscopic instruments 3 are inserted only through the umbilicus of the patient, the close proximity of the instruments to each other results in the so-called chopstick effect, which is a significant limitation to the manipulation of conventional laparoscopic instruments 3 through conventional trocars 1.

As shown in FIG. 2A and FIG. 2B, an exemplary C-shaped trocar sleeve or cannula 7 is generally an elongated tube having a proximal end 15 and a distal end 17. In one exemplary embodiment the C-shape curve through ends 15, 17 is bent so that each end portion forms an angle of approximately 30° with respect to a tangent to the center of the trocar sleeve or cannula 7. However, any angle, which sufficiently reduces the chopstick effect, may be used. Thus, exemplary embodiments with angles from 5-45° may be used. A C-shaped trocar sleeve or cannula 7 may be made of conventional material as is known in the art. The interior diameter of a C-shaped cannula 7 is preferably around 5 mm. However, in alternate embodiments the interior diameter of the C-shaped cannula 7 may range from 2-15 mm. In one exemplary embodiment, the C-shape is relatively fixed and does not vary, for example when the cannula has a rigid composition. In an alternate exemplary embodiment, the C-shaped cannula 7 is more flexible allowing the surgeon or surgical assistant to bend the cannula 7 changing the angle of the C-shape, for example, via insertion of an instrument into the cannula.

In an alternative design, trocar sleeve or cannula 7 is made of a flexible material with a memory. Trocar sleeve 7 or cannula 7 may have a straight or linear cylindrical configuration in a relaxed state, i.e., in the absence of externally applied forces. Sleeve or cannula 7 assumes the curved or arcuate configuration shown in FIG. 2A upon the insertion through the cannula of a laparoscopic instrument shaft with a curved or arcuate section of sufficiently greater rigidity than the cannula. Cannula 7 then bends through the application of external forces to take the arcuate form shown in FIG. 2A.

FIG. 2C illustrates an exemplary S-shaped laparoscopic instrument 10. The S-shaped laparoscopic instrument 10, has for example, a shaft 10a with a preformed inherently S-shaped configuration including a proximal curve 20 and a distal curve 21. Examples of laparoscopic instruments 10 which can be formed generally into an S-shape include but are not limited to scissors, clamps, dissectors, staplers, clip applicators, retrieval bags, and electrocautery instruments. Instruments 10 include a manual actuator 10b at a proximal end and an operative tip 10c at a distal end. The S-shaped shaft 10a may be substantially rigid throughout. Alternatively, shaft 10a or a portion thereof, for example, distal curve 21, may be semi-rigid and flexible so that the shaft may be deformed from the S-shaped configuration to an at least partially straightened configuration upon application of deformation forces to the shaft. In the latter case, the shaft is made of a material with a memory so that the shaft automatically returns to the S-shaped configuration after relaxation of deformation forces. In another alternative, proximal portion 20 is rigid while distal portion 21 is flexible. Distal portion 21 is flexed into substantially rigid C-shape by a locking mechanism (not separately shown), controlled by actuator 10b, so the instrument assumes a rigid S-form when needed by the surgeon. In any event, the S-shape for these instruments can be achieved, for example, by using conventional manufacturing techniques modified to accommodate the S-shape contour of the instrument.

As illustrated in FIG. 3, a generally S-shaped laparoscopic instrument **10** may be inserted through a C-shaped trocar sleeve or cannula **7**. For example, the proximal curve **20** of the S-shaped instrument **10** corresponds to the curve of the C-shaped cannula **7**. The distal curve **21** of the S-shaped instrument **10** also corresponds to the curve of the C-shaped cannula **7** and when inserted through the C-shaped cannula **7** will be, for example, entirely within the abdominal cavity **5** of the patient. A C-shaped cannula **7** and S-shaped laparoscopic instrument **10** allows the surgeon to perform the laparoscopic procedure without making incisions outside of the umbilicus. In accordance with the present invention, the size and curvature of a C-shaped cannula **7** will correspond to the size and curvature of an S-shaped instrument **10** and can include any desired size.

This arrangement of C-shaped cannula **7** and S-shaped instrument **10** eliminates the "chopstick effect" which results from the insertion of conventional laparoscopic instruments **3** through the umbilicus. For example, the proximal curves of the S-shaped instruments **10** and the C-shaped cannula **7** allows the surgeon's hands and the proximal portions of the instruments **20**, including the instruments' handles, to be placed as far apart as is convenient for the surgeon. For example, workspace **9a** is created. Movement of the proximal portion of one instrument **20** away from the proximal portion **20** of the other also markedly separates the exposed (e.g. outside the body cavity) shafts of each instrument. The distal curve of the S-shaped instrument **21** creates workspace **9b** between the portions of the instruments in the abdominal cavity and redirects the distal end of the laparoscopic instrument **10** back toward a target site **8**, such as an abdominal organ or other abdominal structure or site.

Thus, an S-shaped laparoscopic instrument **10** may be thought of as having four segments or sections to allow an abdominal procedure to be performed entirely through the umbilicus and yet overcome the "chopstick effect" encountered with conventional laparoscopic instruments **3** and cannulas **1**. First, the portion outside of the patient's abdominal cavity **5** allows sufficient space between the surgeon's hands when manipulating the proximal portion of the laparoscopic instruments **10**. Second, the portion at or near the umbilicus, which allows a laparoscopic instrument **10** to enter the abdominal cavity **5** is in close proximity to one or more additional laparoscopic instruments **10** so that all instruments **10** enter the abdomen through the umbilicus. Third, the portion beyond the second portion, which creates separation between laparoscopic instruments **10** within the abdominal cavity **5**. Fourth, the distal end of a laparoscopic instrument **10** is shaped to point back toward the target abdominal organ, tissue or other site.

Examples of procedures which can be facilitated by the use of C-shaped trocar sleeves or cannulas **7** and S-shaped laparoscopic instruments **10** include, but are not limited to diagnostic laparoscopy, cholecystectomy, appendectomy, salpingectomy, oophorectomy, treatment of infertility and extrauterine pregnancy, hysterectomy, removal of a section of bowel, a variety of gastric procedures, biopsy of various abdominal organs, including liver, and hernia repair.

The following discussion describes, as an example, a cholecystectomy procedure as described in FIGS. 2A-C and FIG. 3. It should be noted, however, that many other laparoscopic procedures may be performed using various embodiments disclosed herein. The following description, therefore, is merely illustrative and is not intended to limit the present invention to the description given in this example.

A laparoscopic procedure, such as a cholecystectomy, using a curved C-shaped flexible or rigid trocar sleeve or

cannula **7** and S-shaped laparoscopic instruments **10** is performed with the patient under general anesthesia. Carbon dioxide gas is insufflated intra-abdominally to 15 mm Hg through a 5 mm lateral umbilical incision, using for example, a VERESS™ needle. For example, two curved C-shaped 5 mm cannulas **7** are then inserted through an incision in the umbilicus. The surgeon operates, for example, a 5 mm endoscope with one hand and a 5 mm S-shaped laparoscopic instrument **10** with the other, each of which is passed through a respective cannula **7**.

The cannula for the endoscope could be straight so that a conventional straight endoscope could be used, the other curved cannula **7** providing separation between the instruments and the surgeon's hands. Pericholecystic adhesions, if present, are removed by blunt or sharp dissection using an S-shaped dissector to expose the dome of the gallbladder. A 2-0 nylon (or other suitable material) stay suture on a needle is placed through the abdominal wall immediately below the right costal margin at the right anterior axillary line, allowing for superior retraction of the gall bladder dome. The removal of the adhesions from around the gallbladder infundibulum is then continued as necessary. A second stay suture is placed through the right flank and then through the neck of the gallbladder allowing for lateral retraction to expose the cystic structures. The Cystic duct and cystic artery are dissected, then ligated with clips, utilizing a 5 mm S-shaped clip applicator, and then finally transected with an S-shaped scissors. With continued retraction from stay sutures, the gallbladder is removed from the liver bed utilizing an S-shaped electrocautery device equipped with a hook, dissecting the gallbladder from medial to lateral and inferior to superior direction. The perihepatic area is then irrigated using an S-shaped irrigation/suction device.

The above-described procedure is greatly facilitated by the use of S-shaped laparoscopic instruments **10** and C-shaped cannulas **7**, allowing the procedure to be performed entirely through the umbilicus while at the same time reducing or eliminating the "chopstick effect". For example, each of the S-shaped laparoscopic instruments is inserted and removed from the active curved cannula **7** as needed during the procedure and conflict with the endoscope is avoided. Thus, as a result, improved cosmesis, reduced operative and post-operative complications, and a less complicated surgical technique are achieved.

FIG. 4A and FIG. 4B illustrate an inflatable cannula holder **30** having, for example, multiple C-shaped trocar sleeves or cannulas incorporated within the unit **30**. The lateral wall **34** of the inflatable cannula holder unit **30** may vary from extremely flexible and stretchable when deflated, thus facilitating insertion into the umbilical incision, to somewhat rigid when inflated during the surgical procedure. The inflatable unit **30** has, for example, a horizontal upper plate **31** and a horizontal lower plate **32**. Curved or arcuate trocar sleeves or cannulas **33a**, **33b**, and **33c** will extend through separate and mutually spaced apertures (not designated) in the horizontal upper plate **31** and separate and mutually spaced apertures (not designated) in the horizontal lower plate **32** and may be incorporated within the lateral wall **34**. Cannulas **33a**, **33b**, **33c** may be rigid or flexible members. One or more straight trocar sleeves or cannulas **33d** may also be provided which traverse holder unit **30** and particularly upper surface **31** and lower surface **32** thereof. Any given straight cannula **33d** may be rigid or flexible. In the latter case, the cannula **33d** may be sufficiently flexible to bend in conformation to a generally C-shaped section **20** or **21** (FIG. 2C) of laparoscopic instrument **10**. Shaft **10a** or section **20**, **21** thereof is either rigid or has a sufficiently rigidity to force the bending of cannula **33d**.

One or more of cannulas **33a**, **33b** and **33c** may similarly be flexible members with a memory tending to return the cannulas to a straight or arcuate configuration.

Rigid sections may be inserted or attached around the periphery of the horizontal upper **31** or lower **32** plate to add stability. The horizontal upper plate **31** and horizontal lower plate **32** may be, for example concave or straight. At least one and possibly two or more C-shaped trocar sleeves or cannulas **33a**, **33b**, **33c**, (described previously) can be incorporated within the lateral wall **34** of the inflatable unit **30** and are distributed, for example, evenly around the wall **34** of the unit **30**. The upper **31** and lower plate **32** are preferably made of a flexible plastic material or other suitable surgical quality material.

In an alternate embodiment, the inflatable unit **30** has one or more C-shaped trocar sleeves or cannulas **7** incorporated within its lateral wall **34**, and one or more straight cannula **1**, also incorporated within the inflatable unit's lateral wall **34**. The straight cannula may accommodate, for example, a straight endoscopic or laparoscopic instrument, while the C-shaped cannulas **7** can accommodate an S-shaped instrument **10** as described above. Thus, even where one of the instruments is relatively straight and passes through a relatively straight cannula **1**, the chopstick effect is still reduced as a result of the remaining C-shaped cannulas **7** and S-shaped instruments **10**, which provide space between the surgeons hands, the proximal portions of laparoscopic instruments (which includes the straight laparoscope), and the distal ends of the laparoscopic instruments (which also include the straight laparoscope).

Inflatable unit **30** may include one or more passageways **40a** and **40d** formed by generally cylindrical webs of resilient material (not separately designated) connected at opposite ends to upper surface **31** and lower surface **32**. Upon inflation of unit **30**, the webs close the passageways and, upon insertion of respective cannulas **33a** and **33d**, form a sealed engagement therewith. In one possible mode of use, cannulas **33a** and **33d** are inserted through passageways **40a** and **40d** only after placement of unit **30** in an opening formed in a patient and upon inflation of the unit. Alternatively, all cannulas **33a**, **33b**, **33c**, **33d** may be disposed within and coupled to unit **30** prior to the positioning thereof in the patient.

The surgeon may place the inflatable unit **30** through an approximately 1.5 to 2.5 cm incision in the umbilicus. The unit **30** is inserted prior to inflation with the C-shaped cannulas **33a**, **33b**, **33c**, for example, parallel and in close proximity to each other. The upper plate **31** will remain outside of the umbilicus while the lower plate **32** is located just inside the abdominal cavity **5**. Once the unit **30** is properly positioned, the surgeon or assistant may inflate the unit **30**. The unit **30** may be inflated via, for example, a one-directional valve using a syringe or gas line inserted into a narrow hollow tube connected to the unit **30** as is known in the art. The syringe or gas line may be alternatively inserted directly into a one-directional valve. Thus, means for inflating the unit **30** can be similar to the means for inflating a conventional endotracheal tube.

In an exemplary embodiment, the diameter of the inflatable unit **30** increases upon inflation. The unit may be inflated to the extent needed for the particular laparoscopic procedure. By placing the trocar sleeves or cannulas in the lateral walls of the inflatable unit, the surgeon may position a trocar sleeves or cannulas, and thus an instrument inserted through a cannula, as far away from the other cannulas and instruments as possible within the confines of a chosen space such as the umbilicus. In addition, the surgeon may change the position of the cannulas and instruments within the umbilicus by rotat-

ing the inflatable unit **30** around its vertical axis. Moreover, the inflatable unit **30** seals the opening of the patient's abdominal cavity **5** to prevent leakage of CO<sub>2</sub> from the abdominal cavity.

In an alternate embodiment as shown in FIG. **8**, the distance between the upper plate **31** and the lower plate **32** may be reduced, thereby increasing the ability of the trocar sleeve or cannula **7** to move in relation to the wall of the inflatable unit **30**. This design, where the distance between **31** and **32** is reduced to form the "plate member," is preferred. The plate member is located perpendicular to the axis of the cannula holder and anywhere within its walls.

Thus, as an example, the cholecystectomy procedure described above may be performed using the inflatable unit **30** in conjunction with S-shaped laparoscopic instruments **10**, rather than using separate cannula/instrument arrangements. Once the gallbladder is transected and removed from the liver bed, it is removed through the 1.5 to 2.5 mm incision along with the inflatable unit **30**. If necessary, the initial incision can be extended to remove the gallbladder. Alternatively, the gallbladder may be opened to remove or crush and remove gallstones, facilitating removal of the gallbladder through the umbilical incision.

As shown in FIG. **5A** and FIG. **5B**, an inflatable unit **70** includes a single C-shaped trocar sleeve or cannula (not separately designated) having a radially expandable and inflatable balloon-like structure **75** incorporated within the hollow lumen **73** of the cannula. A single laparoscopic instrument may be inserted within this inflatable unit **70**.

Unit **70** may then be inflated to secure the cannula and laparoscopic instrument together as one movable unit. The inflatable unit **70** may be inflated via, for example, a one-directional valve using a syringe or gas line inserted into a narrow hollow tube **74** connected to the unit **70** as is known in the art. The syringe or gas line may be alternatively inserted directly into a one-directional valve. Thus, means for inflating the unit **70** can be similar to the means for inflating a conventional endotracheal tube inflating the inflatable unit **70** also serves to seal the abdomen preventing insufflated gas from escaping through the lumen of the cannula. The inflatable unit **70** may then be deflated, the laparoscopic instrument may be removed, and a different instrument may be inserted.

While the above description of S-shaped instruments **10** and C-shaped cannulas **7** has been directed to procedures performed entirely through the umbilicus, it is to be understood that embodiments of the present invention may be adapted for use in other entry sites. Therefore, when it is desirable to have entry of multiple instruments in a relatively localized area, embodiments of the present invention may be used for such entry, while reducing or eliminating the so-called "chopstick effect". Thus, existing scars or hidden areas such as the pubic hair line or the axillary region may be used as a localized entry site.

As illustrated in FIG. **6**, an angulated bi-directional needle **50** is provided with a first sharp end **51**, a second sharp end **52**, and a surgical thread **55** attached to the angle **57** of the needle **50**. The needle **50** has, for example, a total length of around 5-10 cm. The length of each segment from the angle to sharp end is roughly equivalent, but need not be. An acute angle of around 160° is formed by the angulated needle **50**, however angles **57** ranging from a straight needle, i.e. 180°, to an acute angle **57** of around 90° may be used. The needle is formed out of steel or other suitable material. The surgical thread **55**, such as 2-0 nylon, is attached at the angle **57** of the needle **50**.

The angulated needle **50** simplifies suture delivery through the gallbladder or other abdominal structure. For example, the first sharp end **51** of the needle **50** is inserted through the body

wall by the surgeon. The needle **50** is then grasped within the abdominal cavity **5** by a laparoscopic instrument under endoscopic guidance and is pulled toward the organ of interest. With the second sharp end **52** leading, a stitch is placed through the abdominal structure of interest. The second sharp end **52** is then delivered through the abdominal wall.

The angulated bi-directional needle **50** allows delivery of a switch without changing the orientation of the sharp end as would be necessary if a needle with only one sharp end is used. Changing the direction of the needle with one sharp end to 180 degree laparoscopically might be technically challenging.

An alternative exemplary embodiment of a angulated needle is shown in FIG. 7. In this embodiment the angulated needle **60** has, for example, a long segment **61** with one sharp end **62** on one side of the angle **65**. The needle **60** has a blunt short segment **67** on the other side of the angle **65**. Thread **68** is attached to the end of the blunt short segment **67**.

The angulated needle **60** allows penetration through the body wall as a straight needle. The needle **60** is inserted into and through the wall of the gallbladder. The needle is then flipped 180° and delivered back through the abdominal wall. The angulated needle **60** can be used to reposition a gall bladder or other structure during a laparoscopic procedure by, for example, pulling or relaxing the suture, which eliminates or reduces the need for the insertion of one or more additional cannulas and laparoscopic instruments for that purpose. The angulation of the angulated needle **60** also reduces the chance of iatrogenic injury to surrounding structures by allowing the needle **60** to be flipped and then delivered back through the abdominal wall prior to contacting surrounding abdominal structures.

As illustrated in FIG. 9, a stand-alone laparoscopic medical instrument insertable through a laparoscopic trocar sleeve or cannula comprises an elongate shaft **80** formed of a plurality of a plurality of rigid cylindrical segments including a middle segment **82**, three proximal end segments **84**, **86**, and **88**, and three distal end segments **90**, **92** and **94**. During a laparoscopic procedure utilizing the instrument of FIG. 9, middle segment **82** transverses a laparoscopic cannula, trocar sleeve or instrument holder described herein, while proximal end segments **84**, **86** and **88** are located outside the patient and distal end segments **90**, **92**, and **94** are located inside the patient. An operative tip **96** is disposed at one end of the shaft **80**, more particularly at a free end of distal end segment **94**, and actuator handles or grips **98** are disposed at an opposite end of the shaft, more particularly at a free end of proximal end segment **88**. Actuator handles **98** are operatively connected to operative tip **96** via shaft **80** for controlling the operation of the tip.

Proximal end segments **84**, **86** and **88** form a proximal shaft portion **100** that is independently bendable to form, for example, a C shaped configuration. Proximal end segments **84**, **86**, and **88** are connected to one another via joints or articulations **102** and **104** and to middle segment **82** via a joint or articulation **106**.

Distal end segments **90**, **92** and **94** form a distal shaft portion **108** that is independently bendable to form, for example, a C shaped configuration. Distal end segments **90**, **92**, and **94** are connected to one another via joints or articulations **110** and **112** and to middle segment **82** via a joint or articulation **114**.

Operative tip **96** may be rotatable about a longitudinal axis **115**. Further rotational capability may be provided by including a joint **116**, **118**, **120** along distal end segments **90**, **92** or

middle segment **82**, where relative rotation of proximal and distal parts is effectuated about a longitudinal axis of the respective segment.

Proximal end portion **88** is provided with rotary actuators or knobs **122** for modifying the angles between adjacent distal end segments **90**, **92**, **94**, for rotating operative tip **96** relative to distal end segment **94** about axis **114**, and for implementing the longitudinal-axis rotation at joints **116**, **118**, and/or **120**. Wing-nut-type clamps **124** may be provided at knobs **122** for releasably locking those actuators to maintain the angles between adjacent distal end segments **90**, **92**, **94**, the rotary position of operative tip **96**, and the longitudinal-axis rotation at joints **116**, **118**, and/or **120**.

Clamping elements **126**, **128**, **130** may be provided at the articulations or joints **102**, **104**, **106** for locking the relative positions of middle segment **82**, and proximal end segments **84**, **86**, **88**. Alternatively, further knobs and wing-nut clamps (not shown) may be provided at the proximal end of the instrument for changing the angles between pairs of adjacent segments **82**, **84**, **86**, **88**.

During a laparoscopic surgical procedure, the axial position of the operative tip **96** may be adjusted by sliding the laparoscopic instrument of FIG. 9 into and out of the patient, for example, by modifying the position of the middle segment **82** relative to the respective cannula or instrument holder aperture. In addition, the axial position of operative tip **96** may be changed by adjusting the configuration of distal end portions **90**, **92**, **94** relative to one another. Strongly arced configurations have a shorter axial extent than configurations with more shallow arcs. Further degrees of freedom in the positioning of operative tip **96** relative to a surgical site are provided by the rotatability of operative tip **96** about the axis **114** and the rotatability at joints **116**, **118**, **120**. The positional adjustability provided by articulations or joints **110**, **112**, **114** greatly enhances the practical capabilities of the instrument.

FIG. 10 depicts another stand-alone laparoscopic medical instrument having a shaft **132** insertable through a laparoscopic trocar sleeve or cannula. Shaft **132** has a continuously flexible proximal end portion or segment **134**, a rigid straight middle portion or segment **136**, and a distal end portion **138**. Proximal end portion **134** and distal end portion **138** are connected to opposite ends of middle portion **136** via respective articulations or joints **140** and **142**, so that the proximal end portion and the distal end portion are laterally swingable relative to the middle portion, as indicated by dual headed arrows **144** and **146**. Middle portion **136** constitutes about one-third of the total length of shaft **132**.

Shaft **132** is provided at a proximal end, i.e., at the free end of proximal end portion **134**, with a pair of hand grip actuators **148**, and is further provided at a distal end, i.e., at the free end of distal end portion **138** with an operative tip **150** such as scissors, a forceps, a clamp, a cauterizing element, etc. Operative tip **150** is rotatable about a longitudinal axis **152** relative to the end of distal end portion **138**, as indicated by a bidirectional arrow **154**. As indicated by another bidirectional arrow **157**, proximal end portion **134** and distal end portion **138** may be rotatable relative to one another about a longitudinal instrument axis **156**, owing to a rotatable joint **158** exemplarily provided along middle portion **136**.

Distal end portion **138** includes two segments or sections **160** and **162** pivotably connected to one another via an articulation or joint **164**, as indicated by a dual headed arrow **166**. Distal-most section **162** is continuously bendable along its length into an infinite number of smoothly curved generally C-shaped configurations, as indicated by an arrow **168**. The more proximal section **160** may be rigid and linear or, alternatively, also continuously flexible along substantially its

entire length and formable into a multitude of smoothly arced generally C-shaped configurations.

Proximal end portion **134** is provided along a linear proximal section (separately labeled) with a plurality of actuator knobs **170** and locking elements **172** for controllably modifying (a) the degree of curvature of proximal end portion **134** and distal end portion **138**, particularly distal-most section **162**, (b) the angles between portions **134** and **136** and portions **136** and **138**, (c) the angle between sections **160** and **162**, (d) the degree and direction of rotation of operative tip **150** about axis **152**, and (e) the relative angular position of proximal end portion **134** and distal end portion **138**, as determined by the operational status of joint **158**. By way of illustration, a modified position and curvature of distal-most section **162** is indicated in FIG. **10** at **174**. A modified position of proximal most section **160** and a corresponding modified curvature of distal most section **162** are indicated in phantom at **176**. An alternate position of proximal end portion **134** with respect to middle portion **136** is shown in phantom at **178**.

FIGS. **11A-11F** depict additional possible positional and curvature configurations of the instrument of FIG. **10**, particularly distal end portion **138**.

During a laparoscopic surgical procedure, the axial position of operative tip **150** may be adjusted by sliding the laparoscopic instrument of FIG. **10** into and out of the patient, for example, by modifying the position of middle portion **136** relative to the respective cannula or instrument holder aperture. In addition, the axial position of operative tip **150** may be changed by adjusting the configuration of distal end portion **138**, as depicted in FIGS. **11A-11F**. Strongly arced configurations (FIGS. **11B** and **11C**) have a shorter axial extent than configurations with more shallow arcs (FIGS. **11A**, **11E**). Further degrees of freedom in the positioning of operative tip **150** relative to a surgical site are provided by the rotatability of operative tip **150** about axis **152** and the rotatability at joint **158**.

One or more of the actuator mechanisms including knobs **170** and locking elements **172** may be operatively connected to shaft **132** for bending distal section **162** (and optionally section **160**) in a direction out of the plane of the drawing sheet.

Where proximal portion **134** of shaft **132** assumes a first C-shaped configuration in response to operation of a respective one of the knobs **170** and distal portion **138** (or **162**) of the shaft assumes a second C-shaped configuration in response to operation of a second one of the knobs **170**, the C-shaped configurations may face opposite sides of the shaft, thus forming shaft **132** into a generally S-shape.

As depicted in FIG. **12**, a holder **180** for cannulas and laparoscopic surgical instruments such as those discussed above the reference to FIGS. **9-11F** indicates a plate member **182** having a surrounding or perimetric edge **184** and a wall **186** surrounding the plate member. Wall **186** is provided with a plurality of anchoring elements such as eyelets **187** or hooks **189** for securing the holder **180** to a patient via suture thread.

Wall **186** is connected to a plate member **182** all along edge **184**. Wall **186** has a longitudinal axis **188**, with plate member **182** extending substantially transversely to that axis. Plate member **182** is provided with a plurality of separate and mutually spaced apertures or port members **190**, **192** for receiving respective elongate laparoscopic instruments **194** and **196**. Instrument **194** is configurable to have an S-shaped shaft **198** and may specifically take the form of the instruments discussed with reference to FIGS. **9** and **10-11F**. Instrument **196** is a fiberoptic instrument including a camera **200** in the form of a charge coupled device and a bendable shaft **202**. Shaft **202** has a proximal end portion **260** and a distal end

portion **262** that may be independently flexed into continuous smooth C-shaped configurations as shown in the drawing. Alternatively, shaft **202** may be substantially identical to shaft **132** of the instrument shown in FIG. **10**. The rotational capability discussed above with reference to operative tip **150** and joint **158** may be omitted from laparoscope **196**. Laparoscope **196** has an operative tip **264** provided with the usual illumination aperture and imaging lens (neither shown). Actuators are omitted from the depiction in FIG. **12** of instruments **194** and **196** for purposes of simplicity. An actuator for controlling the operative tip **264** of laparoscope **196** may take the form of conventional controls for illumination and CCD operation, where a CCD is located at the operative tip of the device.

Holder **180** is an inflatable unit, both plate **182** and wall **186** being at least partially hollow for receiving a pressurizing fluid such as air. To that end, a tube **204** is connected to holder **180** for the delivery of air from a pressure source such as a syringe (not illustrated). A valve **206** is provided on tube **204**. A second tube **208** with a valve **210** is connected to holder **180** for providing a channel for the conveyance of an insufflation gas such as carbon dioxide from a reservoir thereof (not shown) to the patient. An aperture **212** is provided along an inner surface **214** of wall **186** for enabling the delivery of the illustration gas to the patient via tube **208**.

Wall **186** has a height dimension **H1** at least as great as, and preferably substantially greater than, a height dimension **112** of plate member **182**. Wall **186** has two end portions **216** and **218** extending as endless or annular flanges to plate member **182**. Plate member **182** is located towards an upper end of wall **186**, plate member **182** forming a shallow cup shape and a deep cup shape with flanges **216** and **218**, respectively.

Wall **186** has inner diameters **D1** and **D2** of the free ends flanges **216** and **218**, opposite plate member **182**. These inner diameters **D1** and **D2** are larger than a diameter **D3** of plate member **182**, which is the inner diameter of wall **182** at the plate member. Consequently, cannula and instrument holder **180** has a flared or tapered profile on each side or plate **182**. This flared or tapered shape may exhibit a curved or arced profile as shown in the drawing.

FIG. **13** is a cross-sectional view of holder **180** similar to FIG. **12**, with laparoscopic instruments **194** and **196** removed to show possible valves **220** and **222** included in port members **190**, **192**. Valves **220** and **222** are not part of the present invention. Any known valve structure may be used in port members **190**, **192**.

It is possible for port members **190**, **192** to be disposed entirely within plate member **182**. In that case, the port members incorporate flat valves in the form of flexible, horizontally located membrane with openings for the passage of laparoscopic instruments.

As illustrated in FIG. **14**, a flexible plate member **224** of a cannula and instrument holder **226** similar to that of FIGS. **12** and **13** has separate and mutually spaced apertures **3228** provided with rigid port membranes or cannulas **230** serving in part to elongate the apertures. Port members or cannulas **230** have a curvilinear or arced shape along their longitudinal dimensions and have flanges **232** and **234** that extend outside of plate member **224**. Plate member **224** has a height **H3** in a direction parallel to an axis of **236** of the cannula and instrument holder, which is at least as great as heights **H4** and **H5** of extension flanges **232**.

Cannula and instrument holder **0226** has a side wall **237** that is substantially rigid in a region about plate member **224** and flexible at least in a distal flange region (inside the patient) spaced from plate member **224**. Such a design facilitates cannula insertion in the abdominal wall opening and overall structural integrity of the system while under deforming

external pressure (rigid part), and provides an improved degree of freedom, particularly in the lateral planes, within the system (flexible part).

Plate members **182** and **224**, as well as walls **186** and **238** of holders **180** and **226** are flexible, but can acquire a semi-rigid form upon tilling with inflation fluid. The flexibility of the holders **180**, **226** means that these devices can be rolled or folded into a compact deflated configuration for insertion into the umbilicus or other abdominal aperture. FIG. **15** shows such a compacted insertion configuration of an instrument holder **240** having port members **242**. For assisting in the deployment of the instrument holder **240**, tongs **244** may be used. Tongs **244** have a pair of handles **246** and a pair of substantially cylindrical jaw elements **248**. The compacted instrument holder **240** is held between jaw elements **248** for insertion into the umbilicus. The compacted holder is held by a finger or instrument in place, while tongs **244** are opened slightly (arrow **247**) and pulled (arrow **249**) to separate jaw elements **248** from the holder **240**. The holder **240** is then inflated in the umbilicus to the use configuration.

FIG. **16** depicts another instrument or cannula holder **250** for the insertion of multiple laparoscopic instruments into a patient through a single aperture in the abdominal wall of the patient. Instrument or cannula holder **250** includes a flared annular body member **252** provided at one end with a plurality of tapered or funnel-shaped introduction ports **254**. Ports **254** include apertures **256** for the introduction of laparoscopic instruments as discussed hereinabove.

More particularly, the tapered or funnel-shaped port elements **254** each define a plurality of cross-sectional diameters  $D$  and each of said plurality of tapered funnel-shaped port elements **254** are connected to the flared annular body member **252** and extend proximally in a common direction therefrom, as indicated by the arrow **300**. The taper of each of the tapered funnel-shaped port elements **254** decreases the plurality of cross-sectional diameters  $D$  in the proximal direction indicated by arrow **300**.

The annular body member **252** has a C-shaped flared profile **302** along a longitudinal axis **304**. The annular body member **252** defines a proximal aperture **306** and a perimeter **308**. The plurality of tapered funnel-shaped port elements **254** each defines a distal aperture **310** and a perimeter **312**. At least a portion **312'** of the perimeter **312** of the plurality of tapered funnel-shaped port elements **254** is connected to the perimeter **308** of the proximal aperture **306** of the annular body member **252**.

A remaining portion **314** of the perimeter **312** of at least two of the plurality of tapered funnel-shaped port elements **254** are connected to each other and intersect at a common point of intersection **316** generally coinciding with the center of the proximal aperture **306** of the annular body member **252**. The distal apertures **310** defined by the two or more tapered funnel-shaped port elements **254** span the entire proximal aperture **306** defined by the annular body member **252**.

The term "laparoscopic medical instrument" is used herein to denote all instruments utilizable in the performance of a laparoscopic medical procedure, including surgical instruments and laparoscopes.

While several exemplary embodiments of laparoscopic instruments and cannulas for the performance of laparoscopic procedures entirely through the umbilicus have been described herein, it is to be understood that variations may be made in the laparoscopic instruments and cannulas without departing from the spirit and scope of the present invention as defined by the appended claims.

The invention claimed is:

1. An instrument holder assembly comprising:
  - an annular body member; and
  - a plurality of flexible tapered funnel-shaped port elements, each for receiving a surgical instrument or a portion thereof inserted therein, each defining a plurality of cross-sectional diameters and each of the plurality of tapered funnel-shaped port elements connected to the annular body member and extending proximally in a common direction therefrom, the taper of each of the tapered funnel-shaped port elements decreasing the plurality of cross-sectional diameters in the proximal direction, the plurality of tapered funnel-shaped port elements each defining a pre-instrument insertion configuration and a longitudinal axis when in the pre-instrument insertion configuration,
    - the annular body member being flexible and defining a central longitudinal axis extending between a proximal end and a distal end thereof, the distal end configured for insertion within an opening of a patient,
    - wherein, when the plurality of tapered funnel-shaped port elements are in the pre-instrument insertion configuration, the longitudinal axes defined by the plurality of tapered funnel-shaped port elements are generally parallel to the central longitudinal axis of the annular body member, and
    - wherein the annular body member defines at least a portion of a surgical workspace at a portion of the annular body member that is distal to the plurality of tapered funnel-shaped port elements.
2. The instrument holder assembly as defined in claim 1, wherein the annular body member has a flared profile relative to the central longitudinal axis thereof.
3. The instrument holder assembly as defined in claim 1, wherein the annular body member defines a proximal aperture and a first perimeter and wherein the plurality of tapered funnel-shaped port elements each defines a distal aperture and a second perimeter, and
  - wherein at least a portion of the second perimeter is connected to the first perimeter of the proximal aperture of the annular body member.
4. The instrument holder assembly as defined in claim 3, wherein a remaining portion of the second perimeter of at least two of the plurality of tapered funnel-shaped port elements are connected to each other wherein the distal apertures defined by the at least two tapered funnel-shaped port elements span the entire proximal aperture defined by the annular body member.
5. The instrument holder assembly as defined in claim 1, wherein the instrument holder assembly has an insertion configuration for insertion of the instrument holder assembly through an opening in a patient for at least partial insertion of the instrument holder assembly into a patient cavity, and an in use configuration for use of the instrument holder assembly for access to the patient cavity, and wherein, for the insertion configuration, the annular body member is folded into a compact configuration wherein the annular body member has a compressible cross-sectional dimension, the compressible cross-sectional dimension along the longitudinal axis of the annular body member being less than a dimension of the opening in a patient where the annular body member extends at least partially through the opening in a patient.
6. The instrument holder assembly as defined in claim 5, wherein, for the insertion configuration, the plurality of tapered funnel-shaped port elements are folded into a compact configuration to enable the annular body member to extend at least partially through the opening in a patient.

7. The instrument holder assembly as defined in claim 1, wherein the plurality of tapered funnel-shaped port elements and the annular body member each have a height dimension extending parallel to respective longitudinal axes thereof and configured in a ratio to increase, at the distal end of the instrument holder assembly, the surgical workspace between two or more laparoscopic instruments inserted through the plurality of tapered funnel-shaped port elements and between the hands of a surgeon. 5

8. The instrument holder assembly as defined in claim 1, wherein the annular body member is at least partially curved in a direction parallel to its central longitudinal axis. 10

\* \* \* \* \*

专利名称(译)	腹腔镜仪器和套管针系统及相关手术方法		
公开(公告)号	<a href="#">US8747302</a>	公开(公告)日	2014-06-10
申请号	US13/862832	申请日	2013-04-15
[标]申请(专利权)人(译)	柯惠有限合伙公司		
申请(专利权)人(译)	COVIDIEN LP ,		
当前申请(专利权)人(译)	COVIDIEN LP		
[标]发明人	PISKUN GREGORY		
发明人	PISKUN, GREGORY		
IPC分类号	A61B1/04		
CPC分类号	A61B1/05 A61B1/3132 A61B2017/3447 A61B2017/2908 A61B17/3423 A61B2017/00738 A61B2017/3466 A61B17/00234 A61B17/0218 A61B17/282 A61B17/2841 A61B2017/3486		
其他公开文献	US20130289576A1		
外部链接	<a href="#">Espacenet</a>	<a href="#">USPTO</a>	

摘要(译)

提供腹腔镜器械和套管以完全通过脐管进行腹腔镜手术。通常，通过C形套管针套管或通过套管和器械保持器单元放置的S形腹腔镜器械在经济腹腔镜手术期间提供显著改善的器械自由度。

