



US 20180360485A1

(19) **United States**

(12) **Patent Application Publication**  
**DUPERIER et al.**

(10) **Pub. No.: US 2018/0360485 A1**

(43) **Pub. Date: Dec. 20, 2018**

(54) **LAPAROSCOPIC SCALPEL AND METHOD FOR USE**

*A61B 17/00* (2006.01)

*A61B 17/3209* (2006.01)

*A61B 90/00* (2016.01)

(71) Applicant: **Dsign Surgical Innovations, LLC**, San Antonio, TX (US)

(52) **U.S. Cl.**

CPC ..... *A61B 17/3211* (2013.01); *A61B 17/3417* (2013.01); *A61B 17/00234* (2013.01); *A61B 17/3209* (2013.01); *A61B 90/06* (2016.02); *A61B 2017/0046* (2013.01); *A61B 2090/0811* (2016.02); *A61B 2017/0042* (2013.01); *A61B 2017/00424* (2013.01); *A61B 2017/00455* (2013.01); *A61B 2090/062* (2016.02)

(72) Inventors: **Frank Dauterive DUPERIER**, San Antonio, TX (US); **Michael Vollentine SEGER**, San Antonio, TX (US)

(21) Appl. No.: **16/012,566**

(22) Filed: **Jun. 19, 2018**

**Related U.S. Application Data**

(63) Continuation of application No. 14/923,136, filed on Oct. 26, 2015, now Pat. No. 9,999,439, which is a continuation of application No. 14/053,331, filed on Oct. 14, 2013, now Pat. No. 9,168,058, which is a continuation of application No. 13/035,598, filed on Feb. 25, 2011, now Pat. No. 8,585,725.

(57)

**ABSTRACT**

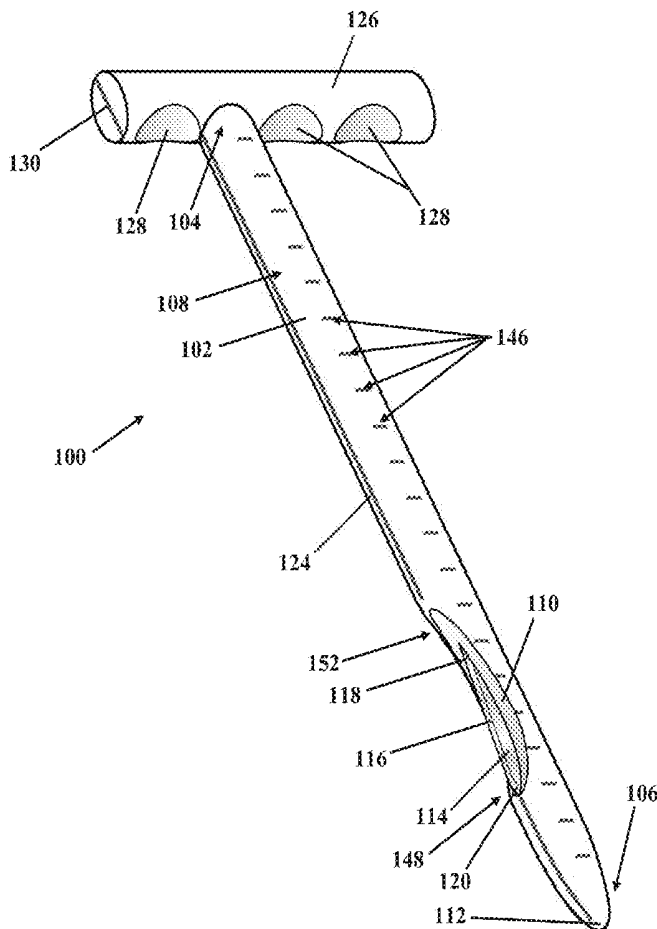
A laparoscopic scalpel includes a shaft and a recess disposed in a surface of the shaft proximal to a distal end of the shaft. A blade is attached to the shaft. The blade includes a cutting edge having a portion exposed by the recess and oriented outwardly from the recess. A proximal end of the portion of the cutting edge exposed by the recess is disposed further from the surface than is a distal end of the portion of the cutting edge exposed by the recess.

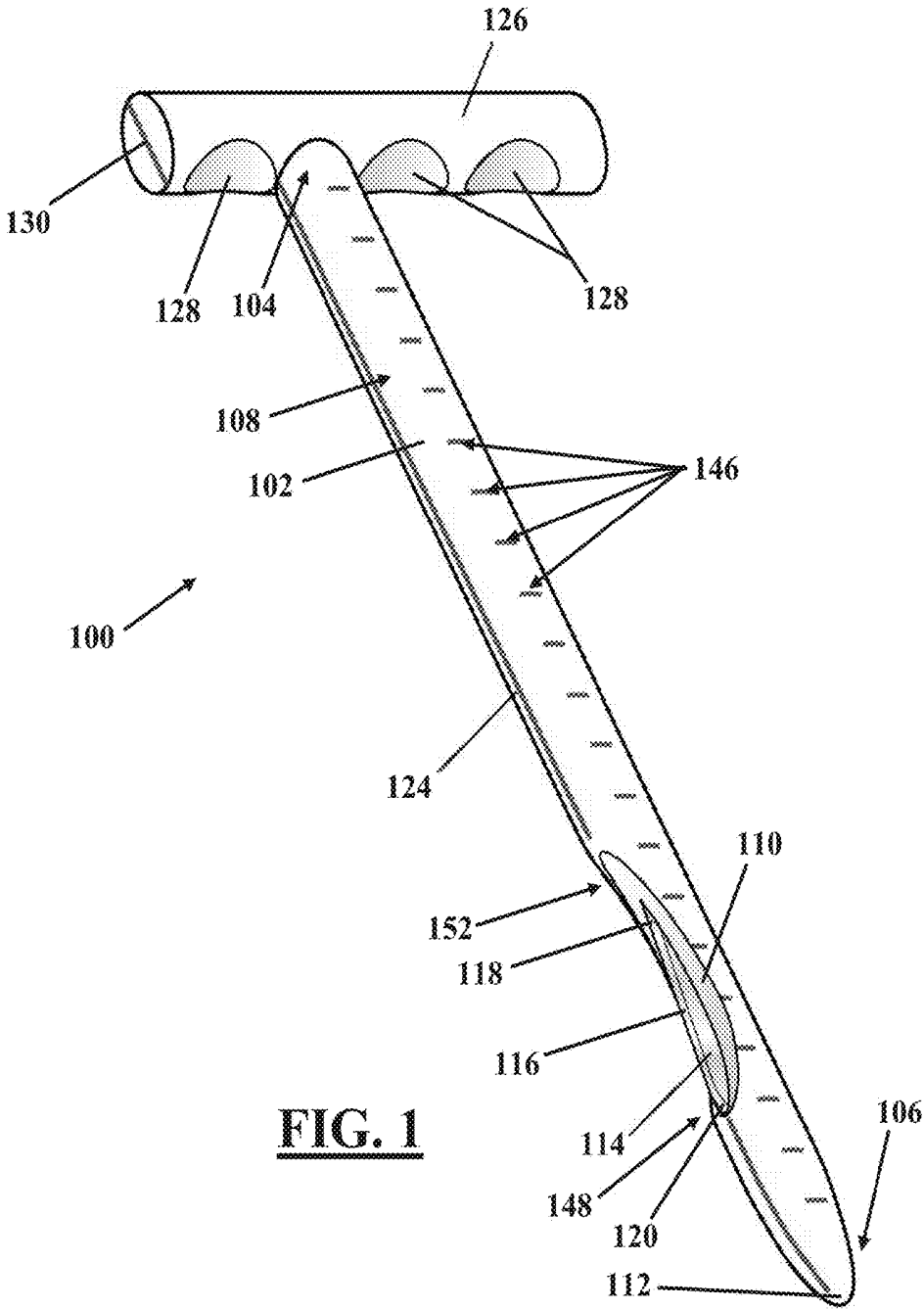
**Publication Classification**

(51) **Int. Cl.**

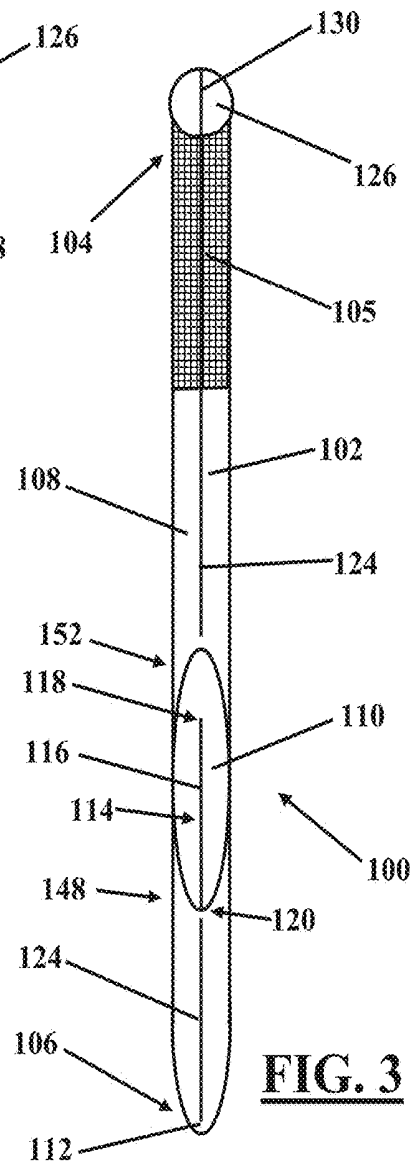
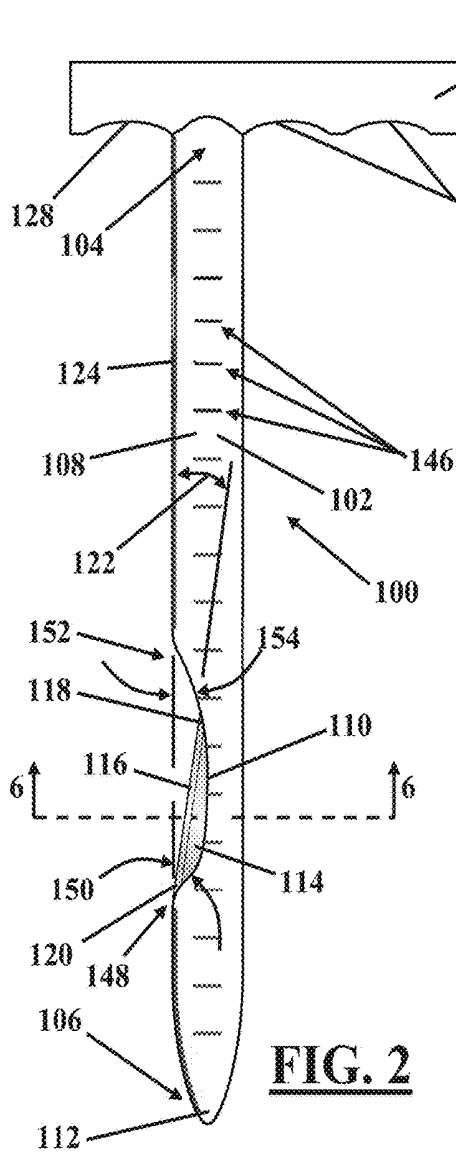
*A61B 17/3211* (2006.01)

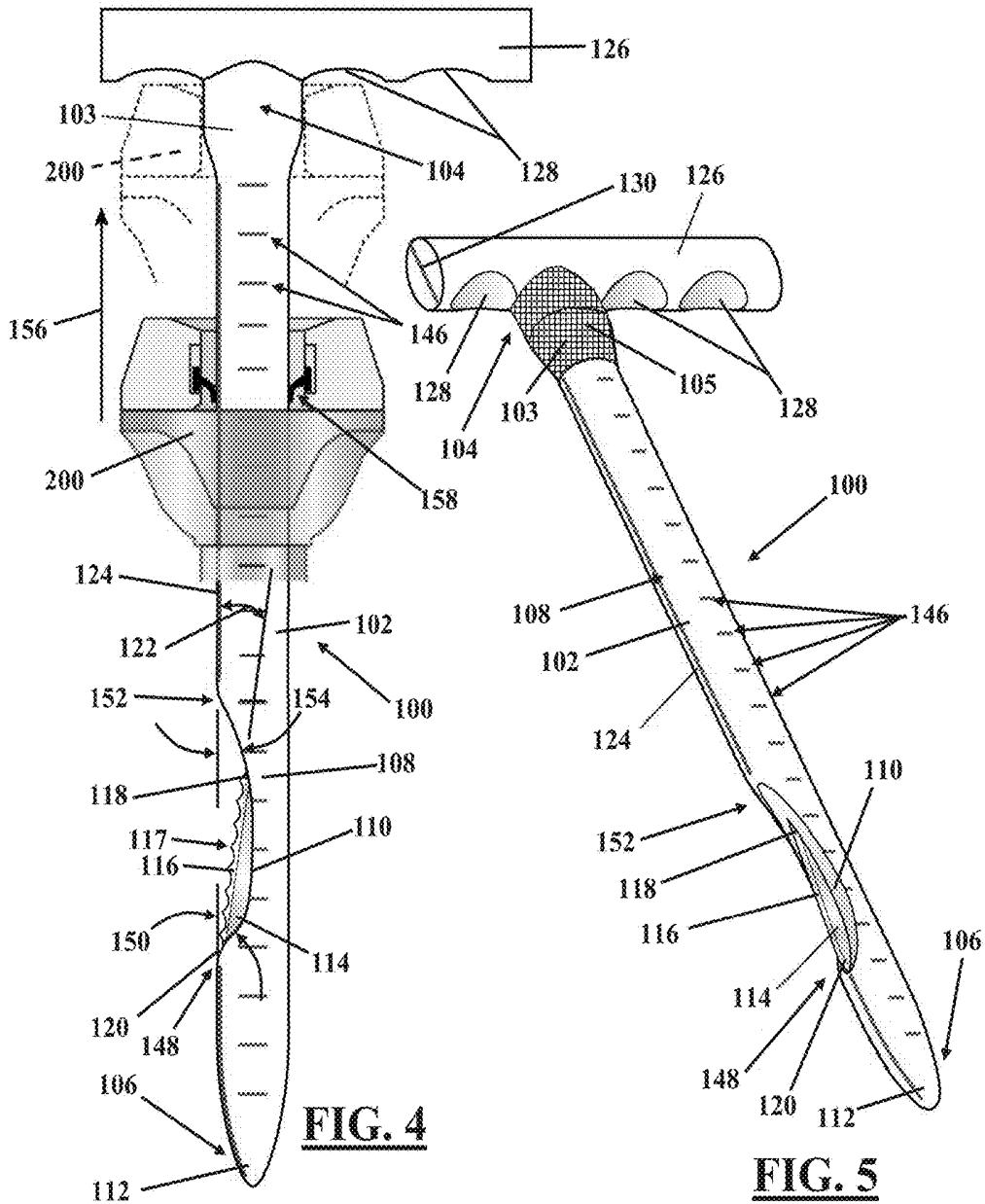
*A61B 17/34* (2006.01)

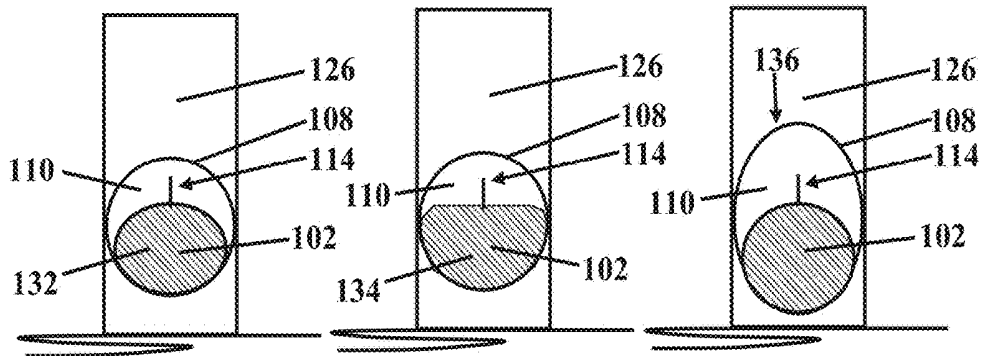




**FIG. 1**



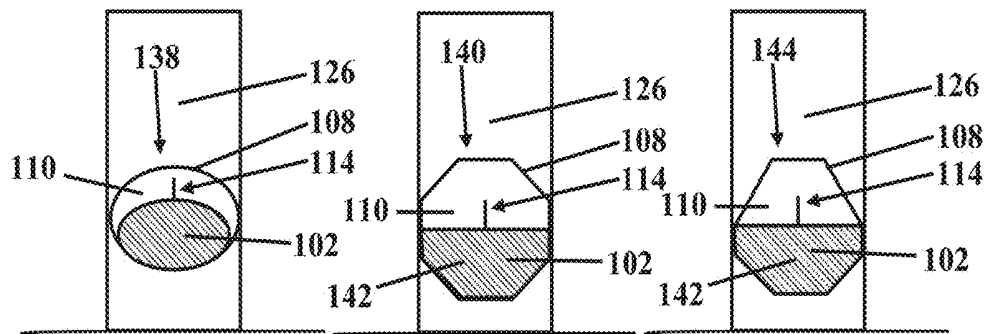




**FIG. 6A**

**FIG. 6B**

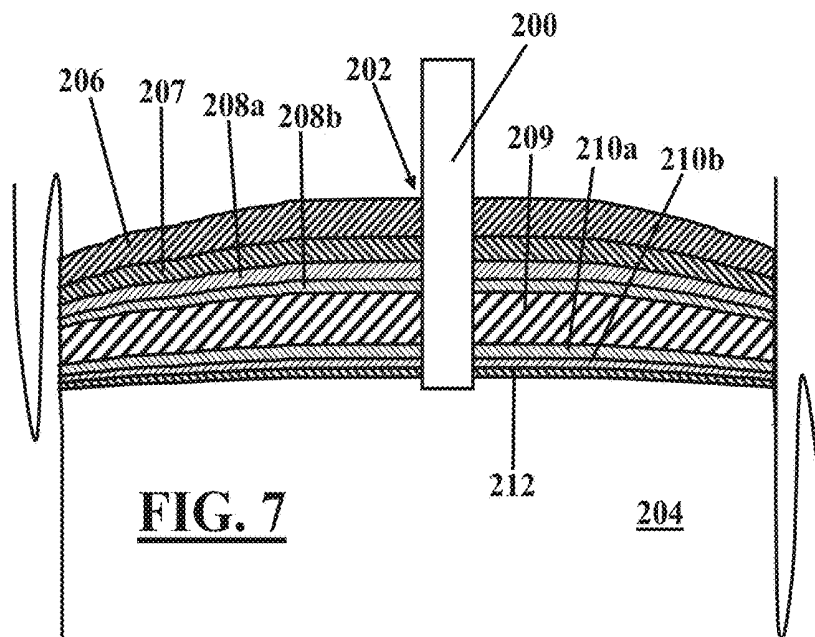
**FIG. 6C**



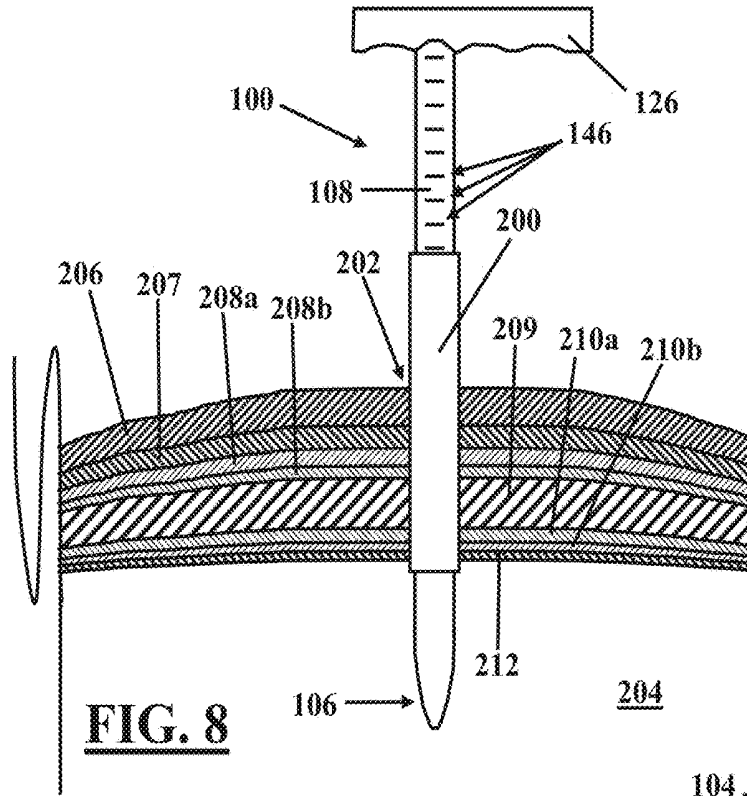
**FIG. 6D**

**FIG. 6E**

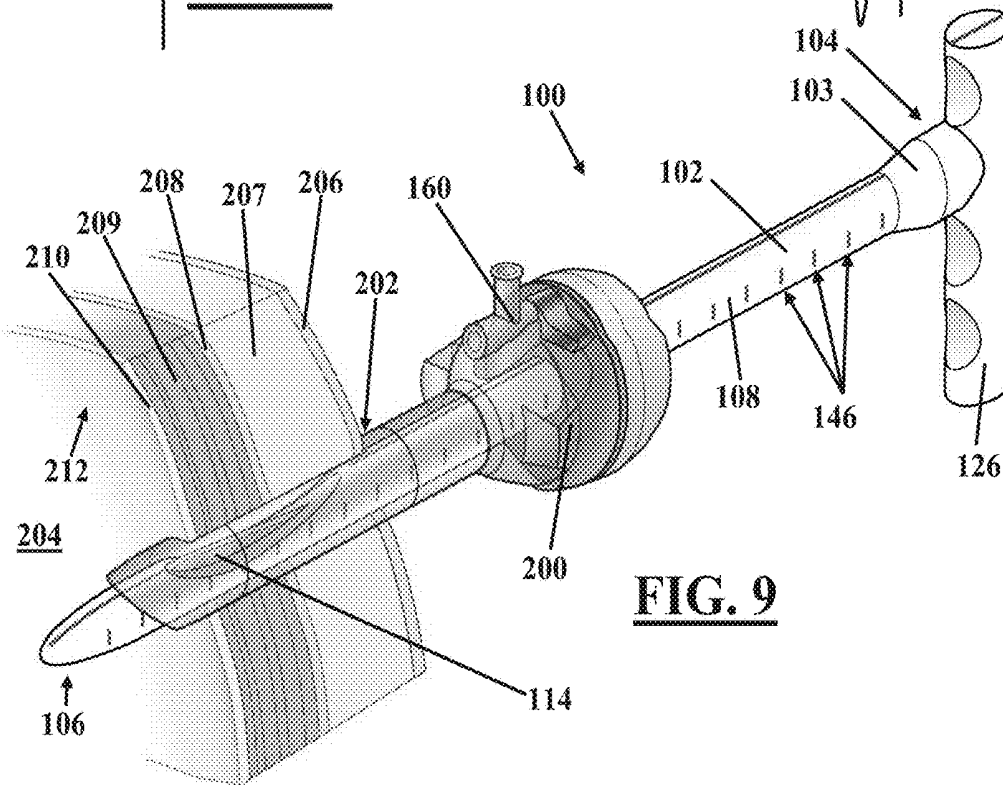
**FIG. 6F**



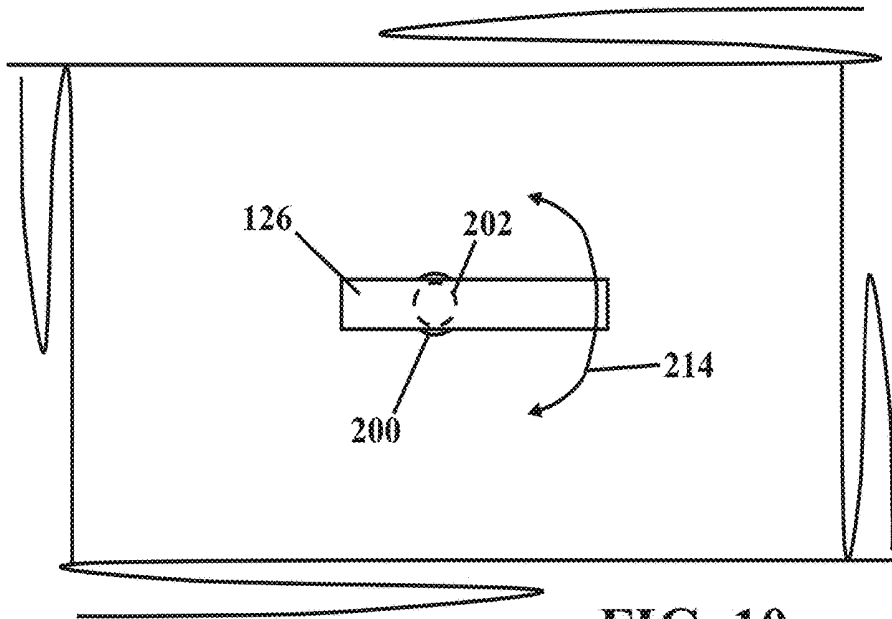
**FIG. 7**



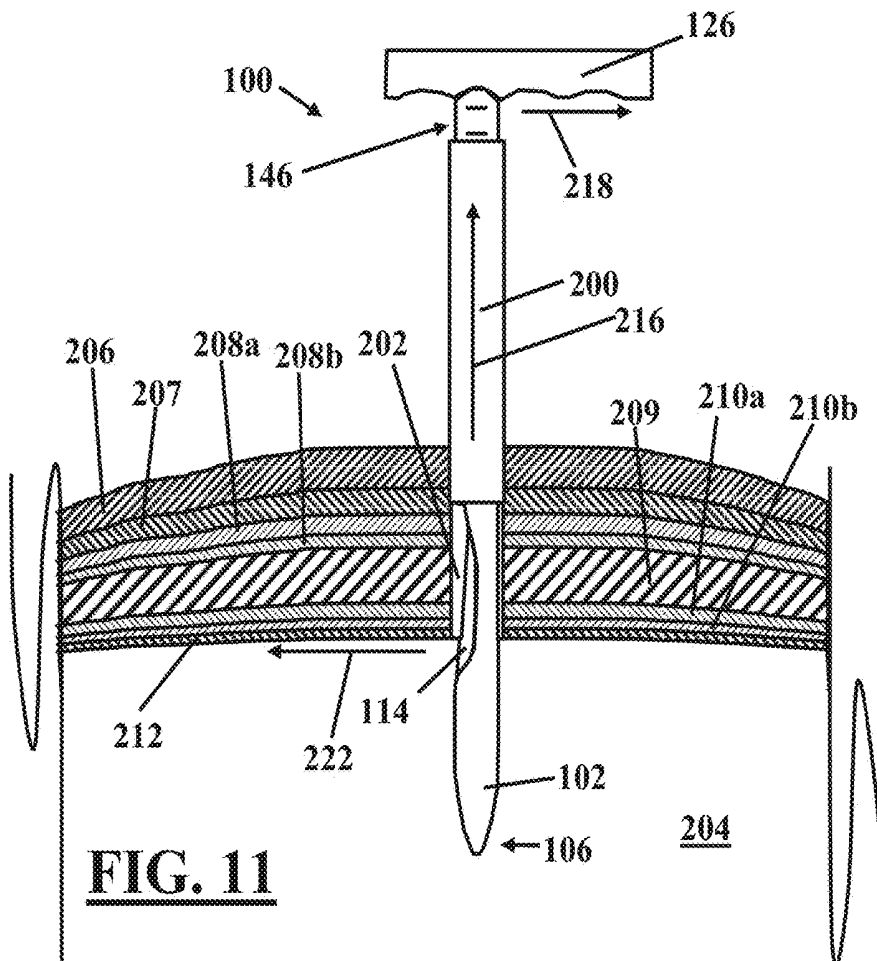
**FIG. 8**



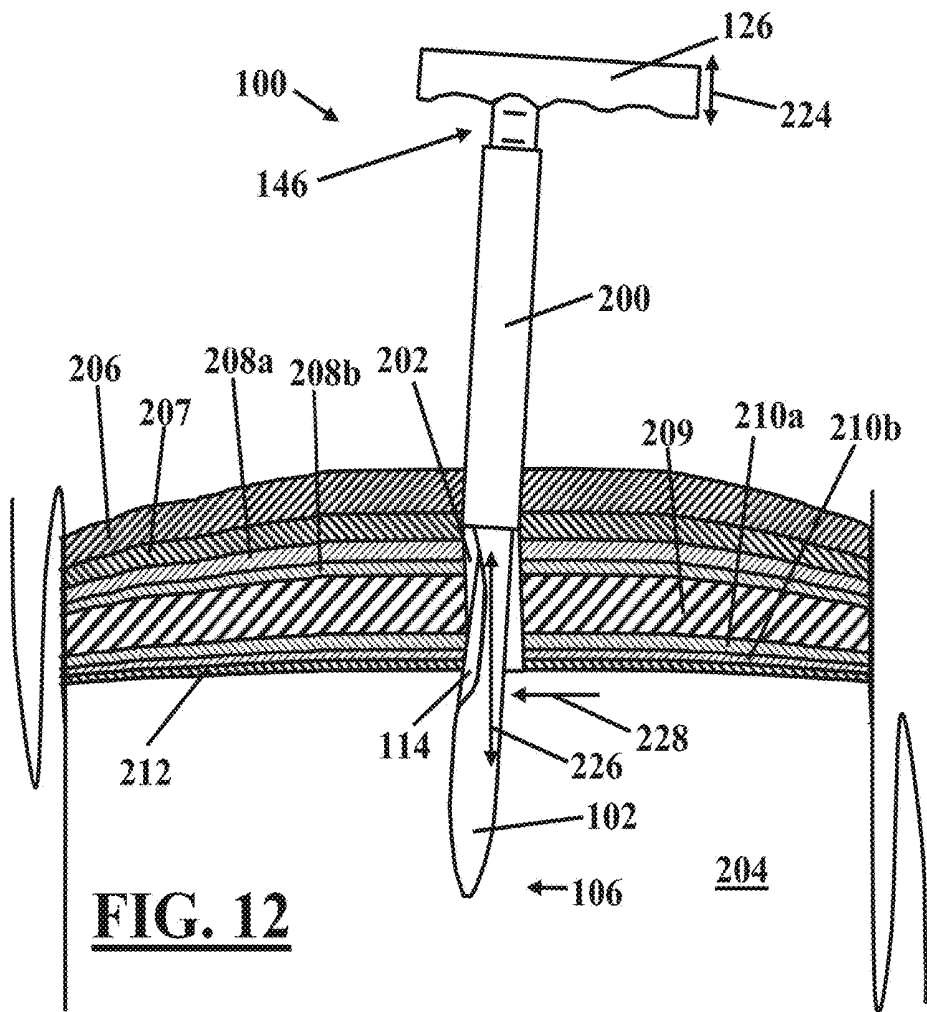
**FIG. 9**

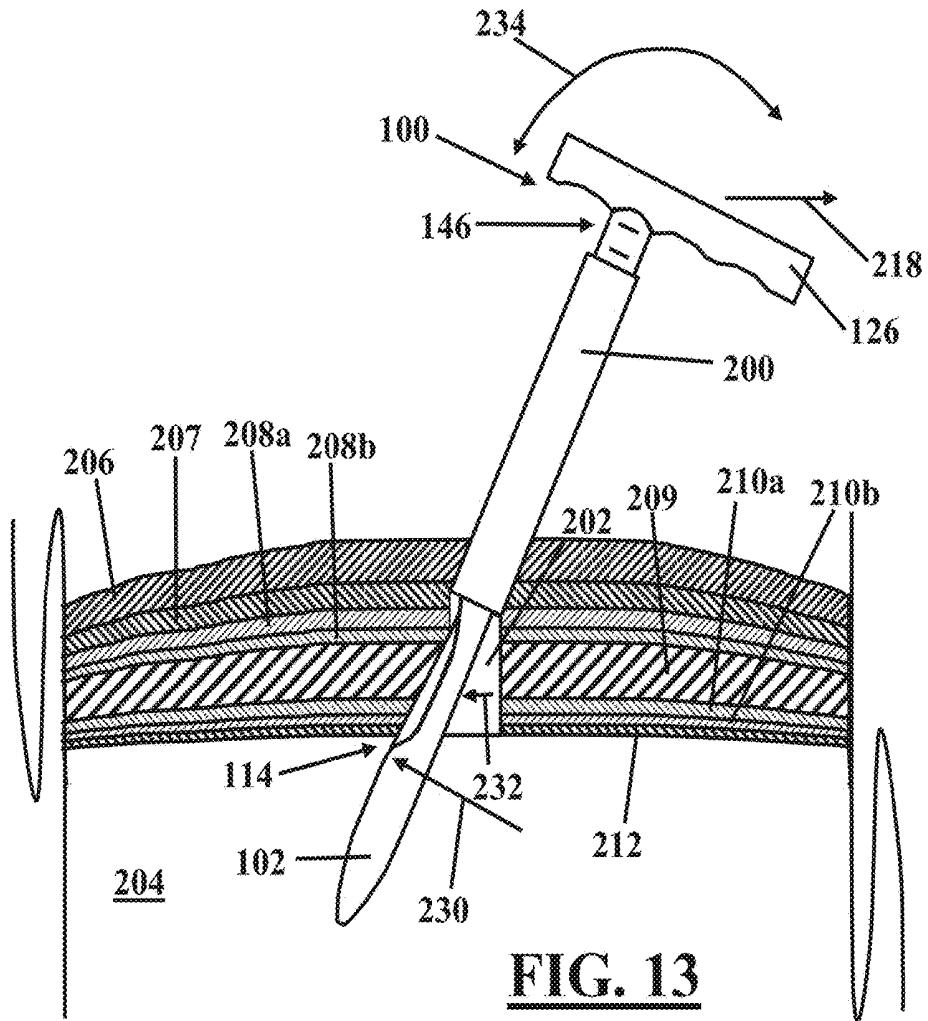


**FIG. 10**



**FIG. 11**





## LAPAROSCOPIC SCALPEL AND METHOD FOR USE

### CROSS-RELATED APPLICATIONS

**[0001]** The present application claims priority from and is a continuation from U.S. patent application Ser. No. 14/923,136, filed Oct. 26, 2015, which claims priority to U.S. patent application Ser. No. 14/053,331, filed Oct. 14, 2013, now U.S. Pat. No. 9,168,058, which claims priority from and is a continuation from U.S. patent application Ser. No. 13/035,598, filed Feb. 25, 2011, which is now U.S. Pat. No. 8,585,725, all of which are herein incorporated by reference in their entireties.

### Field of the Invention

**[0002]** The present invention relates generally to a laparoscopic surgical device. More particularly, the present invention relates to a laparoscopic scalpel that facilitates enlargement of a laparoscopic incision through the peritoneum, fascia, and abdominal wall muscles for extraction of solid organs or other specimens, and/or introduction of intraluminal staplers or other devices.

### BACKGROUND OF THE INVENTION

**[0003]** Laparoscopic surgery, also known as “minimally invasive” surgery, is a method for performing surgery via one or more small incisions typically on the order of about 1 cm across. It is known that laparoscopic surgery offers many benefits to patients and the healthcare system including, for example, less pain, shorter hospital stay, quicker return to normal activity and to work, and better cosmetic results. These benefits make the health care system more efficient; thus laparoscopic techniques are in high demand.

**[0004]** Laparoscopic surgery has revolutionized patient care in the last 20 years. In many cases, minimally invasive approaches have become the standard care, even for specialties such as gynecology, urology, kidney transplant, and foregut surgery. In 2010, there were 2.8 million minimally invasive procedures performed in the United States alone, representing an increase of about 2.6% from 2009. However, these procedures include only about 38% of colectomies and 25% hysterectomies being performed in a minimally invasive fashion. Furthermore, these procedures do not include the usage of the current inventive device in procedures such as adrenalectomy, gastrectomy, donor and pathological nephrectomies, prostates, and liver resections. Therefore, the number of minimally invasive procedures is expected to continue to rise as technology expands.

**[0005]** Furthermore, with the advent of ‘robotic’ surgery more and more techniques are being created. In the past, many surgeons abstained from laparoscopic or robotic techniques because it was felt to not offer an advantage if solid organs required extraction. For example, if a surgeon was doing a colon resection, it was not uncommon for surgeons to perform the operation in an ‘open’ fashion or quickly convert from laparoscopic to open knowing that they were going to require an open incision to extract the solid organ in question.

**[0006]** As more intra-abdominal surgery is being offered with minimally invasive techniques, surgeons need to have the ability to extract a specimen, for example a solid organ, either whole or morcellated. To facilitate the removal of larger solid organs such as, for example, kidneys, adrenals,

the uterus, colon, small bowel, gallbladder, and tumors, a surgeon has to create a sufficiently wide extraction site on the peritoneal surface of the abdominal wall. However, in order to preserve the integrity of the minimally invasive operation, surgeons strive to remove the specimen through the smallest possible skin incision. Therefore, a problem may arise when a specimen needing to be removed is larger than any of the laparoscopic incisions.

**[0007]** Currently, there is no reliable ‘sharp’ option available for lengthening a laparoscopic incision. For example, if an organ requires extraction, the skin is cut with a scalpel; however, the fascia, muscle, and peritoneum are all bluntly ‘ripped’ and spread apart by the surgeon’s fingers or a blunt instrument to allow for extraction of the organ. This blunt method, while adequate, is imprecise, takes increased time to execute, and leads to a considerable amount of tissue trauma, causing increased postoperative pain. In addition, this blunt method leads to the instant loss of the pneumoperitoneum, which is gas normally sealed within the body cavity. Such loss of the pneumoperitoneum may result in a massive expulsion of carbon dioxide gas and aerosolized body fluid when the organ is removed under pressure of the pneumoperitoneum. Such expulsion may expose the surgeons and operating room technologists to an infectious disease hazard and therefore is a safety issue.

**[0008]** Although not widely used, a “fascia scalpel” manufactured by LiNA Medical in Glostrup, Denmark, is designed to be inserted next to a specimen bag which is being pulled up against the abdominal wall. This creates problems as the bag will tend to surround and engulf the LiNA scalpel, and the specimen bag can be cut which can lead to loss of integrity of the bag, loss of containment of the specimen, and potential dissemination of contaminated fluid, for example, an infected appendix, or cancerous cells, for example, a malignant tumor. Thus, the scalpel is designed for cutting more superficially on the abdominal wall or the more dorsal part of the skin and is not designed for the more ventral part of the abdominal wall. The LiNA fascia scalpel is designed for use with smaller solid organs like the appendix and/or gallbladder. The LiNA fascia scalpel is not designed to be placed through a trocar, nor does the LiNA scalpel have a blunt distal end to protect tissue from unintended damage. Additionally, the LiNA fascia scalpel does not enable surgeons to use the instrument under visualization nor does it allow surgeons to work without releasing the pneumoperitoneum.

**[0009]** Further issues exist with using a traditional surgical scalpel to enlarge a laparoscopic incision. For example, when using a regular surgical scalpel attached to a standard or longer handle, it is possible that the scalpel blade may be dislodged from the handle by the abdominal wall tissue and/or the rubber housing of existing trocars if the scalpel is introduced inside the trocar. In addition, standard cutting with a scalpel is not protected and surrounding tissues can be unintentionally injured. Further, a traditional surgical scalpel or a LiNA fascia scalpel can slip and fall freely into the abdomen creating an enterotomy (bowel injury) and thus have potentially devastating consequences.

**[0010]** A need exists for a laparoscopic scalpel that can precisely enlarge a laparoscopic incision without compromising the pneumoperitoneum. Such a device would safely, quickly, and efficiently incise the peritoneum, fascia, and abdominal wall muscles to extract solid organs or introduce intraluminal staplers or other devices. Such a device would

allow for extraction of larger specimens, which allows for wider applicability across multiple specialties including, but not limited to urology, gynecology, general surgery, bariatric surgery, endocrine surgery, colorectal surgery, liver surgery, and thoracoscopic surgery of the chest.

#### SUMMARY OF THE INVENTION

**[0011]** one aspect of the present invention, a laparoscopic scalpel includes a shaft and a recess disposed in a surface of the shaft proximal to a distal end of the shaft. A blade is attached to the shaft. The blade includes a cutting edge having a portion exposed by the recess and oriented outwardly from the recess. A proximal end of the portion of the cutting edge exposed by the recess is disposed further from the surface than is a distal end of the portion of the cutting edge exposed by the recess.

**[0012]** In another aspect of the present invention, a laparoscopic scalpel includes a shaft and a recess disposed in a surface of the shaft proximal to a distal end of the shaft. A blade is attached to the shaft. The blade includes a cutting edge having a portion exposed by the recess and oriented outwardly from the recess. A proximal end of the portion of the cutting edge exposed by the recess is disposed further from the surface than is a distal end of the portion of the cutting edge exposed by the recess. A handle is disposed on a proximal end of the shaft and extends from the shaft along a plane that is generally parallel to the cutting edge.

**[0013]** In a further aspect of the present invention, a method for using a laparoscopic scalpel is presented. The laparoscopic scalpel includes a shaft, a recess disposed in a surface of the shaft proximal to a distal end of the shaft, and a blade attached to the shaft. The blade includes a cutting edge having a portion exposed by the recess and oriented outwardly from the recess. The portion of the cutting edge exposed by the recess is disposed at a non-zero angle relative to the surface. The shaft is adapted to be inserted through a trocar into a patient while generally maintaining the patient's pneumoperitoneum. The method includes the steps of inserting a distal end of the shaft into a trocar disposed within a laparoscopic incision, translating the trocar proximally relative to the shaft to expose one or more of the fascia, muscle, and peritoneum to the cutting edge while generally maintaining the patient's pneumoperitoneum, and cutting the one or more of the fascia, muscle, and peritoneum or other dorsal part of the abdominal wall with the cutting edge to enlarge the laparoscopic incision without compromise of the patient's pneumoperitoneum.

**[0014]** The foregoing and other features and advantages are defined by the appended claims. The following detailed description of exemplary embodiments, read in conjunction with the accompanying drawings is merely illustrative rather than limiting, the scope being defined by the appended claims and equivalents thereof.

#### BRIEF DESCRIPTION OF THE DRAWINGS

**[0015]** In the accompanying figures, like elements are identified by like reference numerals among the several preferred embodiments of the present invention.

**[0016]** FIG. 1 illustrates an isometric view of an embodiment of a laparoscopic scalpel.

**[0017]** FIG. 2 illustrates a side elevation of the laparoscopic scalpel of FIG. 1.

**[0018]** FIG. 3 illustrates a side elevation of another embodiment of a laparoscopic scalpel.

**[0019]** FIG. 4 illustrates a side elevation of a further embodiment of a laparoscopic scalpel disposed in relation to a proximal end of a trocar.

**[0020]** FIG. 5 illustrates an isometric view of yet another embodiment of a laparoscopic scalpel.

**[0021]** FIGS. 6A-6F illustrate cross-sectional views of embodiments of a laparoscopic scalpel taken generally along the lines 6-6 of FIG. 2.

**[0022]** FIG. 7 illustrates a cross-sectional view of a trocar disposed through layers of tissue.

**[0023]** FIG. 8 illustrates a cross-sectional elevational view of insertion of an embodiment of the laparoscopic scalpel of the current invention into a body cavity via a trocar.

**[0024]** FIG. 9 illustrates a cross-sectional isometric view of insertion of another embodiment of the laparoscopic scalpel of the current invention into a body cavity via a trocar.

**[0025]** FIG. 10 illustrates rotationally orienting the laparoscopic scalpel of the current invention following insertion thereof into a trocar.

**[0026]** FIG. 11 illustrates lateral and proximal manipulation of the laparoscopic scalpel of the current invention relative to an incision.

**[0027]** FIG. 12 illustrates an embodiment for enlarging a laparoscopic incision that includes a longitudinally reciprocating motion of the cutting edge.

**[0028]** FIG. 13 illustrates an embodiment for enlarging a laparoscopic incision that includes a transverse slicing motion of the cutting edge.

#### DETAILED DESCRIPTION OF THE DRAWINGS

**[0029]** The foregoing and other features and advantages of the invention are apparent from the following detailed description of exemplary embodiments, read in conjunction with the accompanying drawings. The detailed description and drawings are merely illustrative of the invention rather than limiting, the scope of the invention being defined by the appended claims and equivalents thereof.

**[0030]** Language indicative of a relative geometric relationship between components includes use of the terms "proximal" and "distal" herein. In this context, "proximal" refers to an end of a component nearest to the medical practitioner during use and "distal" refers to the end of the component furthest from the medical practitioner during use.

**[0031]** Referring to FIGS. 1-3, in one embodiment, a laparoscopic scalpel 100 includes a shaft 102 having a proximal end 104, a distal end 106 and a surface 108. A recess 110 is disposed in the surface 108 of the shaft 102 proximal to the distal end 106 of the shaft 102. In one embodiment, the distal end 106 has a blunt end surface 112. A blade 114 is attached to the shaft 102 and includes a cutting edge 116. In one embodiment, the cutting edge 116 may include serrations 117, as illustrated in FIG. 4. The blade 114 may be attached to the shaft by any method as known in the art, including by way of example and not limitation, being overmolded by the material of the shaft, attached to the shaft via a fastener, and being constructed integrally from the same material as the shaft.

**[0032]** The blade is disposed relative to the shaft such that a portion of the cutting edge 116 is exposed by the recess 110 and is oriented outward relative to the recess 110. The

portion of the cutting edge 116 exposed by the recess 110 includes a proximal end 118 and a distal end 120. In one embodiment, the cutting edge 116 is linear between the proximal and distal ends 118, 120. In other embodiments, the cutting edge 116 may be convex, concave, or a combination of convex, concave and/or linear between the proximal and distal ends 118, 120. As will be more fully described hereinbelow, in one embodiment, the proximal end 118 may be disposed further from the surface 108 than is the distal end 120. In this embodiment, if the cutting edge 116 is linear, there results a non-zero angle 122 (See FIG. 2) between the cutting edge 116 and a region of the surface 108 replaced by the recess 110.

[0033] Because no portion of the blade 114 extends beyond the surface 108, the blade 114 may be completely shielded by any tube or shield that can be fit over the shaft 102. Such protection provides safety against unintentional application of the cutting edge 116 to tissue. Configuration of the recess 110 proximal to the distal end 106 of the shaft 102 provides a region of the surface 108 between the blade 114 and the distal end 106 of the shaft 102. Such configuration may provide further safety against an end of the blade 114 extending to near or past the distal end 106.

[0034] In another embodiment, the surface 108 near the proximal end 104 of the shaft 102 may include a rubberized or otherwise textured and/or compressible material 105, as illustrated by the cross-hatched region in FIG. 3. In another embodiment, the proximal end 104 of the shaft 102 may include a tapered or enlarged portion 103, as illustrated in FIG. 4. In a further embodiment, the proximal end 104 of the shaft 102 includes the enlarged portion 103 including the rubberized or otherwise textured and/or compressible material 105, as illustrated by the cross-hatched region in FIG. 5. The enlarged portion 103 and/or the material 105 may facilitate anchoring or docking a trocar or sheath 200 (See FIG. 4) to the proximal end 104, such as for example, when the trocar 200 is slid proximally relative to the shaft 102 as illustrated by arrow 156 in FIG. 4. Such docking may help to stabilize the trocar or sheath 200 while operating the laparoscopic scalpel 100.

[0035] Referring to FIGS. 1-5, in another embodiment, an edge guide 124 may be disposed longitudinally along the surface 108 generally aligned with the cutting edge 116. The edge guide 124 provides an indication of the direction that the cutting edge 116 is facing when the cutting edge 116 is not visible to the surgeon, for example, when the laparoscopic scalpel 100 is inserted into a trocar or other sleeve 200 (See FIGS. 7-13). The edge guide 124 may be a visible line on the surface 108, and/or may include a tactile component such as a raised rib or groove along the surface 108. The addition of a tactile component may be helpful to a surgeon in the event that the surface 108 becomes obscured by fluid or other material.

[0036] In a further embodiment of the laparoscopic scalpel 100, a handle 126 is disposed on the proximal end 104 of the shaft 102. As will be more fully explained hereinbelow, the handle 126 is oriented transversely to the shaft 102, as illustrated in FIGS. 1, 2, 4, and 5. In one embodiment, the handle 126 extends transversely from the shaft 102 in a direction that is generally normal to the edge guide 124. In another embodiment, the handle 126 is disposed on the proximal end 104 of the shaft 102 and extends transversely from the shaft 102 along a plane that is generally parallel to the cutting edge 116. In a further embodiment, the handle

126 is detachably disposed on the proximal end 104 of the shaft 102. Such detachable attachment may be via a press fit, a snap fit, a threaded attachment, a bayonet attachment, matching of a particular shaped rib and groove, and the like.

[0037] Transverse extension of the handle 126 relative to the shaft 102 may provide a medical professional with additional leverage or an improved angle for grasping the handle 126. Such additional leverage or improved grasping angle may facilitate easier manipulation of the blade 114 disposed proximate the distal end 106 of the shaft 102 opposite the handle 126. Transverse extension of the handle 126 also provides a safety feature as will be further described hereinbelow.

[0038] In one embodiment, the handle 126 may further include finger grips 128 disposed thereon to facilitate an improved grip on the handle 126 by a medical professional. In yet another embodiment, instead of or in addition to the edge guide 124 that is disposed longitudinally along the surface 108, an edge guide 130 may be disposed on an edge of the handle 126 in general alignment with the cutting edge 116, as illustrated in FIGS. 1 and 3-5. Similar to the edge guide 124, the edge guide 130 may be a visible line and/or may include a tactile component such as a raised rib or groove.

[0039] Referring to FIGS. 6A-6F, the shaft 102 of the laparoscopic scalpel 100 may have any cross-sectional shape disposed in any orientation relative to the handle 126 as desired. Further, the shaft 102 may include any cross-sectional shape in regions outside of the recess 110 combined with any cross-sectional within the bounds of the recess 110. For example, referring to FIG. 6A, the shaft 102 may have a generally round cross-sectional shape outside of the recess 110 as indicated by the generally round surface 108, and may have a generally elliptical shape 132 within the bounds of the recess 110. Referring to FIG. 6B, for example, the shaft 102 may have a generally semi-circular shape 134 within the bounds of the recess 110. In other embodiments, the shaft may have an elliptical or oval shape 136 that has a long axis thereof aligned with the blade 114, as illustrated in FIG. 6C. Alternatively, the shaft 102 may have an elliptical or oval shape 138 having a short axis thereof aligned with the blade 114, as illustrated in FIG. 6D.

[0040] The shaft 102 may have other cross-sectional shapes and orientations, including without limitation, any closed curvilinear shape such as generally round, elliptical, or oval, any regular polygonal shape, and any irregular polygonal shape. For example, referring to FIG. 6E, the shaft 102 is illustrated as having a regular octagonal shape 140 in regions outside of the recess 110. Within the recess 110, the shaft is illustrated as having a half-regular octagonal shape 142. In another example, referring to FIG. 6F, the shaft 102 has an irregular polygonal shape including seven sides of uneven length 144 in regions outside the recess 110, yet has the half-regular octagonal shape 142 within the recess 110.

[0041] In another embodiment, the laparoscopic scalpel 100 may include regularly spaced distance markings 146 disposed along the surface thereof, as illustrated in FIGS. 1-5. As will be described more fully hereinbelow, the distance markings indicate a depth of insertion of the shaft 102 when inserted into a trocar or other sleeve 200 (See FIGS. 7-13). The distance markings 146 may be visible lines on the surface 108, and/or may include a tactile component such as raised ribs or grooves along the surface 108. Similar

to the edge guides **124**, **130**, the addition of a tactile component to the distance markings **146** may be helpful to a surgeon in the event that the surface **108** becomes obscured by fluid or other material.

[0042] Any of the various embodiments of the laparoscopic scalpel described hereinabove with regard to FIGS. 1-6F may be used to enlarge a laparoscopic incision without losing a patient's pneumoperitoneum. For example, referring to FIG. 7, a trocar or sealing sheath **200** is illustrated inserted via an incision **202** through the various layers of tissue into a body cavity **204**. The trocar **200** includes a seal (for example, reference numeral **158** illustrated in FIG. 4) through which other surgical tools may be passed without disturbing the seal. Thus, the interior of the trocar **200** may be exposed to a patient's pneumoperitoneum upon insertion of the trocar **200** as illustrated in FIG. 7. However, the seal inhibits release of the patient's pneumoperitoneum from within the trocar **200**.

[0043] The various layers of tissue present at a point of entry into the body cavity **204** differ depending on location of the incision **202**. For example, a typical cross-sectional profile of layers in the abdominal region includes, for example, skin **206**, subcutaneous tissue (mainly fat) **207**, ventral fascia **208** including superficial fascia **208a** and deep fascia **208b**, multiple layers of muscle **209**, dorsal fascia **210** including transversalis fascia **210a** and subserous fascia **210b**, and the peritoneum **212**. Of course, each of these layers may include one or more sublayers or additional layers as known in the art.

[0044] Referring to FIGS. 8 and 9, in one embodiment of a method for use of the laparoscopic scalpel **100**, the distal end **106** of the shaft **102** is inserted into the trocar or shield **200** already in place within the incision **202** as illustrated in FIG. 7. In one embodiment, as noted hereinabove with regard to FIGS. 1-5, the distance markings **146** disposed along the surface **108** of the shaft **102** provide an indication of depth of insertion of the shaft **102** when inserted through the trocar **200**. When using an embodiment including the distance markings **146**, the step of inserting the distal end of the shaft **102** may further include inserting the distal end of the shaft **102** into the trocar **200** to a desired depth of insertion. The desired depth of insertion may be determined by the desired depth of the blade **114** relative to one or more of the layers of tissue **206**, **207**, **208a**, **208b**, **209**, **210a**, **210b**, **212**, or via other determinations as known in the art.

[0045] As noted hereinabove with regard to FIGS. 1-5, in one embodiment, the handle **126** extends transversely from the shaft **102** along a plane that is generally parallel to the cutting edge **116**. In another embodiment, the handle **126** extends transversely from the shaft **102** in a direction that is generally normal to the edge guide **124**, which may be generally aligned with the cutting edge **116**. In a further embodiment, the second edge guide **130** disposed on an edge of the handle **126** may be in general alignment with the cutting edge **116**. Thus, the rotational orientation of the handle **126** is consistent with the rotational orientation of the cutting edge **116**, such that following insertion of the laparoscopic scalpel **100** into the trocar **200**, the cutting edge may be oriented rotationally as desired by rotationally adjusting the position of the handle **126**, as illustrated by arrows **214** in FIG. 10.

[0046] As noted hereinabove with regard to FIGS. 1-5, transverse extension of the handle **126** also provides a safety feature. Referring to FIGS. 8 and 9, for example, should the

laparoscopic scalpel **100** slip from the grasp of a surgeon, the transverse extension of the handle **126** inhibits the laparoscopic scalpel **100** from falling freely into the abdomen or body cavity **204** and possibly creating an enterotomy (bowel injury) having potentially devastating consequences.

[0047] Referring to FIGS. 8 and 9, upon placement of the laparoscopic scalpel **100** at the desired depth and orientation within the trocar **200**, the blade **114** is not exposed to tissue but is shielded from surrounding tissue by the trocar **200**. For illustration purposes, the trocar **200** in FIG. 9 has been drawn as transparent to show the position of the blade **114** therein. Such shielding is an improvement over cutting with existing scalpels, which are not protected and which may thereby cause unintentional injury to tissue.

[0048] The cutting edge **116** of the blade **114** is exposed to tissue by translating the trocar **200** proximally relative to the shaft **102**, as illustrated by arrow **216** in FIG. 11. The trocar **200** may be translated as desired to expose one or more of the layers of tissue **206**, **207**, **208a**, **208b**, **209**, **210a**, **210b**, **212** as desired while generally maintaining the patient's pneumoperitoneum. For example, as illustrated in FIG. 11, the trocar **200** has been translated proximally relative to the shaft **102** to expose the peritoneum **212**, the dorsal fascia layers **210**, the layers of muscle **209**, and the ventral fascia layers **208** to the cutting edge **116** of the blade **114**; however, the trocar **200** maintains a seal with the layer of skin **206** and the layer of subcutaneous tissue **207**, thereby maintaining the patient's pneumoperitoneum.

[0049] Upon exposure of one or more of the layers of tissue **206**, **207**, **208a**, **208b**, **209**, **210a**, **210b**, **212** as desired, the next step is to radially enlarge a dorsal portion of the incision **202** without compromise of the patient's pneumoperitoneum. This may be accomplished by creating a pyramidal type incision **202** that is largest at the most dorsal part of the abdominal wall and that is smallest as it nears the skin level.

[0050] In practice, such a pyramidal type incision **202** may be achieved with the laparoscopic scalpel **100** by application of one or more modes for cutting. In one embodiment, for example, referring to FIG. 11, the handle **126** of the laparoscopic scalpel **100** may be maneuvered laterally as illustrated by arrow **218** relative to the incision **202**. Motion of the handle laterally **218** causes the laparoscopic scalpel **100** and the trocar **200** to pivot such that cutting edge **116** of the blade **114** moves to engage tissue in an opposite lateral direction as illustrated by arrow **222**. Referring to FIG. 12, once so engaged in this embodiment, the handle **126** may be translated in a proximal reciprocating fashion, as illustrated by arrow **224** relative to the trocar **200** and the incision **202**. Such motion allows the one or more of the peritoneum **212**, the dorsal fascia layers **210**, the muscle layers **209** and/or other layers as desired to be cut by moving the cutting edge **116** of the blade **114** relative to the incision **202** in a longitudinally reciprocating sawing type motion, as illustrated by arrow **226** in FIG. 12. Application of the longitudinally reciprocating or sawing type motion **226** effectively enlarges the incision **202** in the direction illustrated by arrow **228**.

[0051] In another embodiment, the cutting edge **116** is maneuvered into cutting engagement with tissue to be incised as described hereinabove with regard to FIG. 11. Referring to FIG. 13, in this embodiment, further motion of the handle laterally **218** causes the cutting edge **116** to cut tissue in a transverse slicing motion as indicated by arrow

**230.** Application of the cutting edge **116** in such transverse slicing motion **230** effectively enlarges the incision **202** in the direction illustrated by arrow **232**.

[0052] In a further embodiment, referring to FIG. 13, a medical professional may gain additional control over the cutting by application of a combination of proximal and lateral motion to the handle **126** as illustrated by the arrow **234**. Such combined motion applies both a longitudinal sawing motion **226** and a transverse slicing motion **230** of the cutting edge **116** to the tissue to be cut.

[0053] Thus, lateral **218** and/or proximal **224** motion of the handle **126** allows a surgeon to manipulate the cutting edge **116** to incise one or more of the layers of tissue **206**, **207**, **208a**, **208b**, **209**, **210a**, **210b**, **212** as desired to enlarge the incision **202** without compromise of a patient's pneumoperitoneum. In this context, features of various embodiments of the laparoscopic scalpel **100** as described hereinabove may provide further advantage in enlarging the incision **202**. For example, as noted hereinabove with regard to FIGS. 1-5, the proximal end **118** of the portion of the cutting edge **116** exposed by the recess **110** is disposed further from the surface **108** than is the distal end **120** of the portion of the cutting edge **116** exposed by the recess **110**. In embodiments having a linear cutting edge **116**, such configuration results in the non-zero angle **122** (See FIG. 2) between the cutting edge **116** and the surface **108**. An instrument having a cutting edge generally aligned with the shaft of the instrument only allows for tissue to be incised at right angles to the shaft of the instrument. However, the blade **114** including the cutting edge **116** configured having a non-zero angle **122** with the surface **108** provides additional mechanical advantage to the surgeon allowing for precise control over the length and location of cuts made by the cutting edge **116** when manipulated via lateral motion **218**, proximal motion **224**, or a combination of proximal and lateral motion **234** of the handle **126**. Such control facilitates precise incision of deeper tissue layers (for example, the peritoneum **212**, the dorsal fascia layers **210**, the layers of muscle **209**, and the ventral fascia layers **208**) while leaving the incision **202** through the skin layer **206** and the subcutaneous tissue layer **207** intact.

[0054] Referring to FIGS. 1-5, the recess **110** may have an unsymmetrical longitudinal shape that may provide additional mechanical advantage to the surgeon to facilitate precise control over the cutting edge **116**. For example, a distal end **148** of the recess **110** may be oriented at a first angle **150** relative to the surface **108** and a proximal end **152** of the recess **110** may be oriented at a second angle **154** relative to the surface **108**. The first angle **150** may be larger, the same as, or smaller than the second angle **154**. Making the first angle **150** larger than the second angle **154**, may, for example, allow the surgeon to precisely create the above described pyramidal type incision having the largest expanse at the most dorsal part of the abdominal wall and tapering up to a smallest expanse as it nears the skin layer **206**. The different (larger angle) at the distal end **148** allows the action of the blade **114** to have better access for tissue penetration to create the desired incision at the deepest levels. Following enlargement of the laparoscopic incision **202**, a surgeon may remove an organ or other tissue from the body cavity **204**.

[0055] Existing methods for enlargement of a laparoscopic incision for removal of an organ or tissue sample are inadequate for several reasons. For example, because the incision **202** is bluntly spread or ripped apart using existing

methods, and such spreading requires access by a surgeon's fingers, the trocar **200** is necessarily removed from the incision **202** prior to such spreading. Although the surgeon quickly plugs the incision **202** with a finger to preserve the pneumoperitoneum, removal of the trocar **200** causes some loss of the pneumoperitoneum, and the loss may result in a spray of fluid from the body cavity **204**.

[0056] Next, the incision **202** through the skin **206** is typically lengthened to accommodate a second finger. Such lengthening of the incision **202** may result in additional loss of the pneumoperitoneum (and additional fluid expulsion from the body cavity **204**). Next, a blunt instrument or two fingers are used to spread the incision **202** by ripping it open. In existing methods, the surgeon frantically attempts to get the incision **202** spread adequately before all gas pressure of the patient's pneumoperitoneum is lost.

[0057] Next, the trocar **200** is reinserted into the incision **202**; however in existing methods such reinsertion is difficult because there is nothing to mark the exact location of the incision **202** or to guide the trocar **200** through the now raggedly enlarged incision **202**, which may not follow a straight path into the body cavity **204**. Upon reinsertion of the trocar **200**, a grasping instrument may be inserted through the trocar **200** and visually guided to grasp hold of the tissue to be removed. With the tissue so grasped, the trocar **200** may need to be removed from the incision **202** a second time if the tissue is too large to be removed through the trocar **200**. Such removal of the trocar **200** from the incision **202** may cause additional loss of the pneumoperitoneum through the raggedly enlarged incision **202**. Next, the tissue is extracted via the raggedly enlarged incision **202**, potentially causing further loss of the pneumoperitoneum.

[0058] Alternatively, using existing methods, some surgeons will controllably release the pneumoperitoneum (equalize pressure, for example, by opening a valve **160** (See FIG. 9) on the trocar **200**) prior to a first removal of the trocar **200** from the incision **202** prior to the spreading thereof. However, the lengthened incision through the skin **206** and/or the ragged nature of the enlarged incision **202** caused by forced spreading or ripping thereof makes subsequent reestablishment of a pneumoperitoneum problematic.

[0059] In contrast to existing methods, by utilizing the apparatus and methods described hereinabove, the incision **202** may be more precisely enlarged below the skin layer **206**. As noted hereinabove, precise enlargement also causes less postoperative pain, may heal faster, and provides better control over loss of the pneumoperitoneum. For example, in a first step, any embodiment of the laparoscopic scalpel **100** described hereinabove with regard to FIGS. 1-6 is introduced into a body cavity **204** via a trocar **200** that has a seal as described hereinabove with regard to FIG. 7. Next, the laparoscopic incision **202** is enlarged using any of the embodiments for enlargement of the incision described hereinabove with regard to FIGS. 8-13.

[0060] Next, a grasping instrument may be inserted through the trocar **200** to be visually guided to grasp hold of the tissue to be removed. With the tissue so grasped, the pneumoperitoneum may be slowly and controllably released by releasing the seal on the trocar **200**. Such release may be accomplished, for example, by opening the valve **160** (See FIG. 9) on the trocar **200** to equalize pressure as known in the art. An outlet of the valve **160** may be connected to a containment system (not shown) to capture efflux of fluid

released through the valve **160**. Following controlled release of the pneumoperitoneum, the tissue is extracted via the enlarged incision **202**.

**[0061]** If the tissue to be removed is small relative to the trocar **200**, the tissue may be removed through the trocar **200**. Alternatively, the trocar **200** is removed from the incision **202** to allow for removal of tissue therethrough. In this case, having an incision **202** that has not been lengthened at the skin layer **206** and that has been cleanly incised at more dorsal layers instead of being ripped open as in existing methods facilitates the maintenance of a seal between the incision **202** and the tissue being withdrawn. Next, the trocar **200** is reinserted into the incision **202** and the pneumoperitoneum may be reestablished. After satisfactory inspection of the surgical field, the surgeon next closes the enlarged incision **202**.

**[0062]** Following enlargement of the laparoscopic incision **202**, in lieu of or as a part of the process of removal of tissue from the body cavity **204**, a surgeon may introduce a device into the body cavity **204**. For example, the surgeon may introduce an intraluminal stapling device into the patient after enlarging the laparoscopic incision **202**. A stapling device may sometimes be inserted into the body cavity **204** to divide tissue or to create a connection between viscera therein. However, some types of staplers such as, for example, a circular stapler, are too large to fit through the trocar **200**. In order to operate such staplers laparoscopically, the incision **202** must be enlarged just enough to allow passage of the stapler, but not so much that the pneumoperitoneum cannot be preserved after the stapler is introduced. Using existing methods, as noted hereinabove, the incision **202** is enlarged by bluntly spreading the tissue layers apart with the surgeon's fingers or a blunt instrument. Such blunt spreading is imprecise and frequently leads to irregularly shaped holes which are more difficult to close and can result in hernia formation. The blunt dissection is also more traumatic and causes more post-operative swelling and pain than a precise incision.

**[0063]** In contrast, using the apparatus and methods described hereinabove with regard to FIGS. 1-13, an enlarged incision **202** may be created having a regularly and precisely shaped hole that is easier to close. Such a hole is also easier to plug with a finger when necessary, for example upon removal of the trocar **200** from the incision **202**. Such a hole is also easier to maintain a seal with objects passed therethrough, for example, the trocar **200** or a stapler, or even tissue being removed therethrough. Following enlargement of the incision **202**, for example, such a hole is created that may allow for removal of the trocar **200** and insertion of a finger into the incision **202** with minimal loss of the pneumoperitoneum (assuming there has been no equalization of pressure prior to removal of the trocar **200**). Subsequently, a stapler or other device may be passed through the incision while maintaining a seal between the device and the incision. Alternatively, the stapler or other device may be passed through the trocar **200**.

**[0064]** A laparoscopic scalpel useful for the enlargement of a laparoscopic incision without loss of a patient's pneumoperitoneum is presented. Such enlargement facilitates extraction of bigger specimens from a body cavity. Extraction of bigger specimens allows for wider applicability across multiple specialties, for example, including, but not limited to urology, gynecology, general surgery, bariatric surgery, endocrine surgery, colo-rectal surgery, liver surgery,

and thoracoscopic surgery of the chest. Such enlargement further facilitates delivery of surgical devices, for example, intraluminal staplers, into the body cavity.

**[0065]** It will be appreciated by those skilled in the art that changes could be made to the embodiments described hereinabove without departing from the broad concepts disclosed therein. It is understood, therefore, that this disclosure is not limited to the particular embodiments disclosed, but it is intended to cover modifications that may include a combination of features illustrated in one or more embodiments with features illustrated in any other embodiments. Various modifications, equivalent processes, as well as numerous structures to which the present disclosure may be applicable will be readily apparent to those of skill in the art to which the present disclosure is directed upon review of the present specification. Accordingly, this description is to be construed as illustrative only and is presented for the purpose of enabling those skilled in the art to make and use the laparoscopic scalpel described herein and to teach the best mode of carrying out the same.

What is claimed is:

1.-20. (canceled)

21. A laparoscopic scalpel, comprising:

a shaft having a proximal end, a distal end, and a length therebetween, wherein the shaft is comprised of a first half shaft and a second half shaft

a button driver, comprising a cylindrical rod, an elevated button serving as a pushdown mechanism and a slot located at the distal end of the cylindrical rod to accommodate a blade holder, wherein said slot creates a recess that houses the blade holder holding the blade in place

a blade holder that is housed within the button driver slot and which is aligned with the length of the button driver slot

a blade attached to a blade holder, wherein the blade includes a cutting edge and wherein a proximal end of the portion of the cutting edge exposed by the slot is disposed further from a straight line between the distal and proximal ends of the slot than is a distal end of the portion of the cutting edge exposed by the recess, when the blade is extended and wherein the cutting edge is completely encased in the slot and aligned with the length of the slot when the blade is retracted

22. A laparoscopic scalpel of claim 21, wherein the shaft is further comprised of a grip handle with two detachable halves, the first half handle connected to the proximal end of the first half shaft and the second half handle connected to the proximal end of the second half shaft, wherein the two half handles are oriented longitudinally along the surface of their respective half shafts.

23. A laparoscopic scalpel of claim 21, wherein the first half handle and the second half handle are each shaped like a patella.

24. A laparoscopic scalpel of claim 21, wherein the first half handle and the second half handle are hollowed out.

25. A laparoscopic scalpel of claim 21, wherein the exterior surfaces of the distal ends of each half shaft comprise remolding added on to the outside surface of each half shaft.

26. A laparoscopic scalpel of claim 21, wherein the distal ends of each half shaft are shaped like hemicycles.

27. A laparoscopic scalpel of claim 21, wherein the interior surfaces of the first half shaft and the second half

shaft are hollowed out and the distal ends of the first half shaft and second half shaft comprise a specialized cavity designed to accommodate the blade holder attached to the blade.

**28.** A laparoscopic scalpel of claim **21**, wherein the button driver is comprised of a cylindrical rod, a pushdown mechanism located at the proximal end of the cylindrical rod, and a slot located at the distal end of the cylindrical rod.

**29.** A laparoscopic scalpel of claim **28**, wherein the pushdown mechanism is comprised of a square-shaped button mounted onto a spring device.

**30.** A laparoscopic scalpel of claim **28**, wherein the slot located at the distal end of the cylindrical rod comprises one open end and is further divided into two half slots.

**31.** A laparoscopic scalpel of claim **28**, wherein the distal ends of the two half slots are shaped like hemicycles and comprise pre-drilled holes oppositely disposed and facing each other, one hole located on the right half slot and the other hole located on the left half slot.

**32.** A laparoscopic scalpel of claim **21**, wherein the blade holder is comprised of two interlocking rectangular surfaces shaped like alligator clips and connected by two pins oppositely located at the proximal and distal ends of the surfaces.

**33.** A laparoscopic scalpel of claim **21**, wherein the blade is comprised of a bottom cutting edge, a top blunt edge, and an open cavity located on the medial surface of the blade whose outline matches the outline of the blade holder.

**34.** A laparoscopic scalpel of claim **22**, wherein the bottom cutting edge is smooth and curved and the top blunt edge is straight and wherein the proximal end is tapered so as to fit into the slot area on the button driver.

\* \* \* \* \*

专利名称(译)	腹腔镜手术刀及使用方法		
公开(公告)号	<a href="#">US20180360485A1</a>	公开(公告)日	2018-12-20
申请号	US16/012566	申请日	2018-06-19
[标]申请(专利权)人(译)	DSIGN手术INNOVATIONS		
申请(专利权)人(译)	DSIGN手术的创新, LLC		
当前申请(专利权)人(译)	DSIGN手术的创新, LLC		
[标]发明人	DUPERIER FRANK DAUTERIVE SEGER MICHAEL VOLLENTINE		
发明人	DUPERIER, FRANK DAUTERIVE SEGER, MICHAEL VOLLENTINE		
IPC分类号	A61B17/3211 A61B17/34 A61B17/00 A61B17/3209 A61B90/00		
CPC分类号	A61B90/06 A61B2090/062 A61B2017/0046 A61B17/00234 A61B2017/0042 A61B17/3211 A61B2017/00424 A61B17/3209 A61B17/3417 A61B2090/0811 A61B2017/00455		
外部链接	<a href="#">Espacenet</a> <a href="#">USPTO</a>		

摘要(译)

腹腔镜手术刀包括轴和设置在轴的表面上靠近轴的远端的凹部。刀片连接到轴上。刀片包括切削刃，切削刃具有由凹槽暴露并从凹槽向外定向的部分。由凹槽暴露的切削刃部分的近端设置得比由凹槽暴露的切削刃部分的远端更远离表面。

