



US 20110301424A1

(19) **United States**

(12) **Patent Application Publication**  
**Steigerwald**

(10) **Pub. No.: US 2011/0301424 A1**  
(43) **Pub. Date: Dec. 8, 2011**

(54) **VAGINAL CUFF CLOSURE SYSTEMS, AND RELATED METHOD FOR KNOT-FREE LAPAROSCOPIC HYSTERECTOMY**

**Publication Classification**

(51) **Int. Cl.**  
*A61B 1/32* (2006.01)  
(52) **U.S. Cl.** ..... **600/235**

(76) **Inventor:** **James J. Steigerwald**, Colorado Springs, CO (US)

(21) **Appl. No.:** **13/035,729**

(22) **Filed:** **Feb. 25, 2011**

(57) **ABSTRACT**

A vaginal cuff closure system includes a speculum having a closed rear aspect, a secure suture ring and a fastener for removably attaching the secure suture ring with a blade of the speculum. A related method of using the closure system in knot-free laparoscopic hysterectomy is also disclosed.

**Related U.S. Application Data**

(60) Provisional application No. 61/352,057, filed on Jun. 7, 2010.

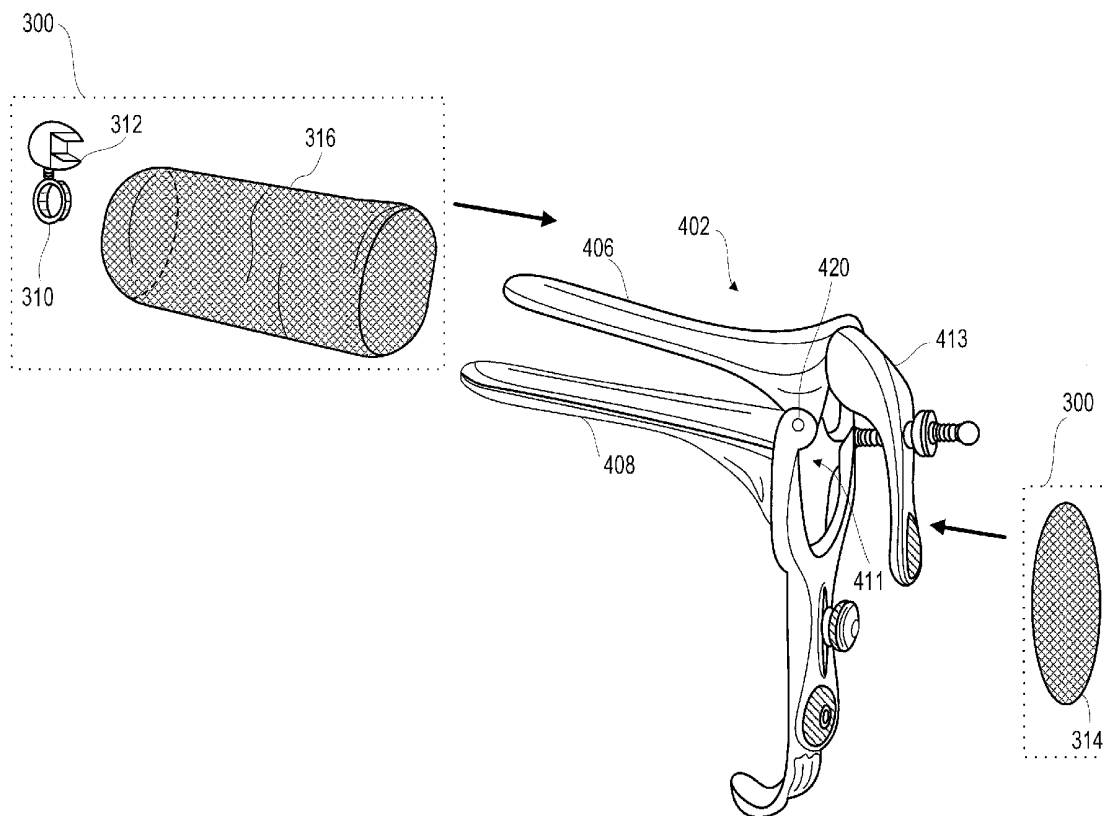

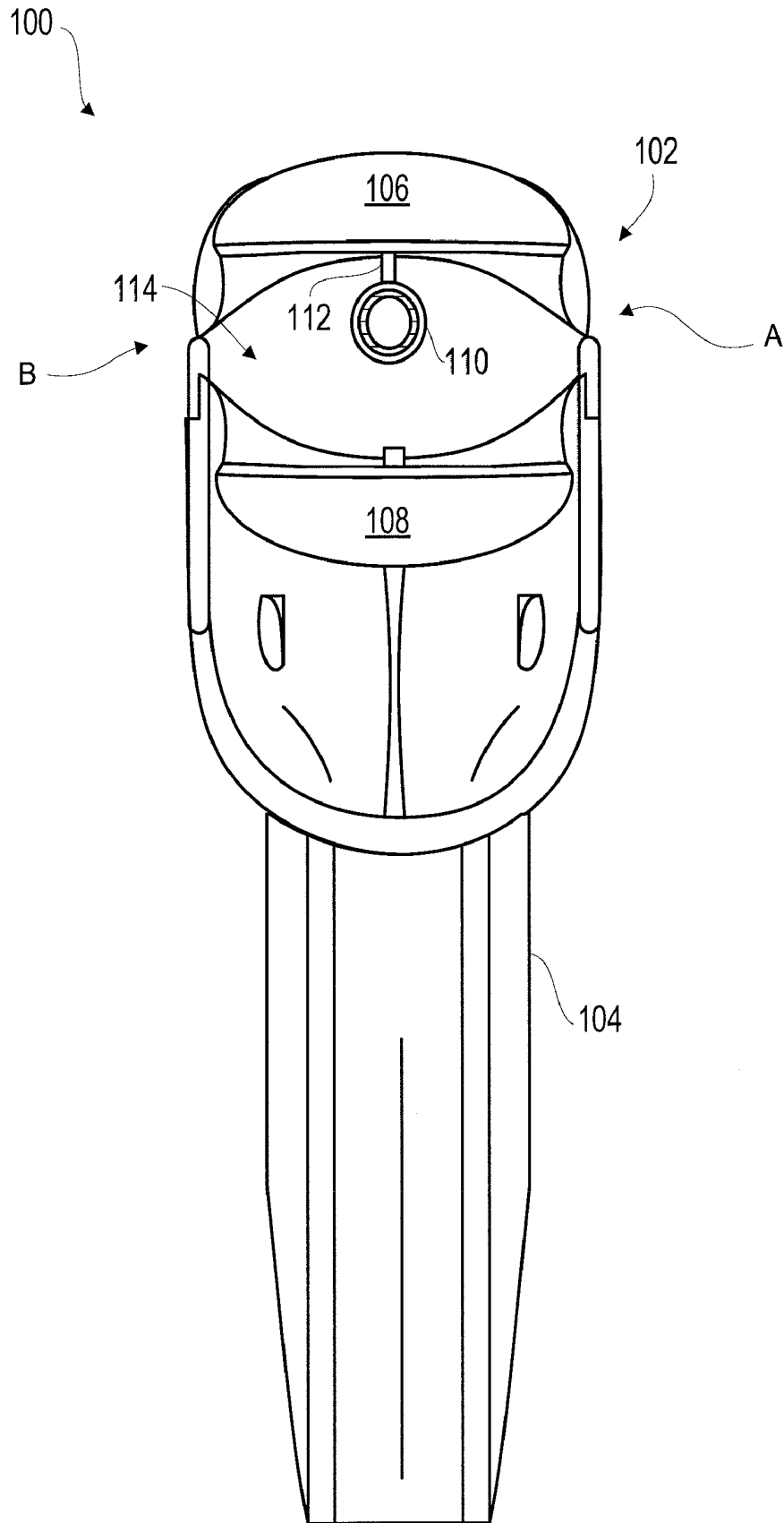

**FIG. 1**

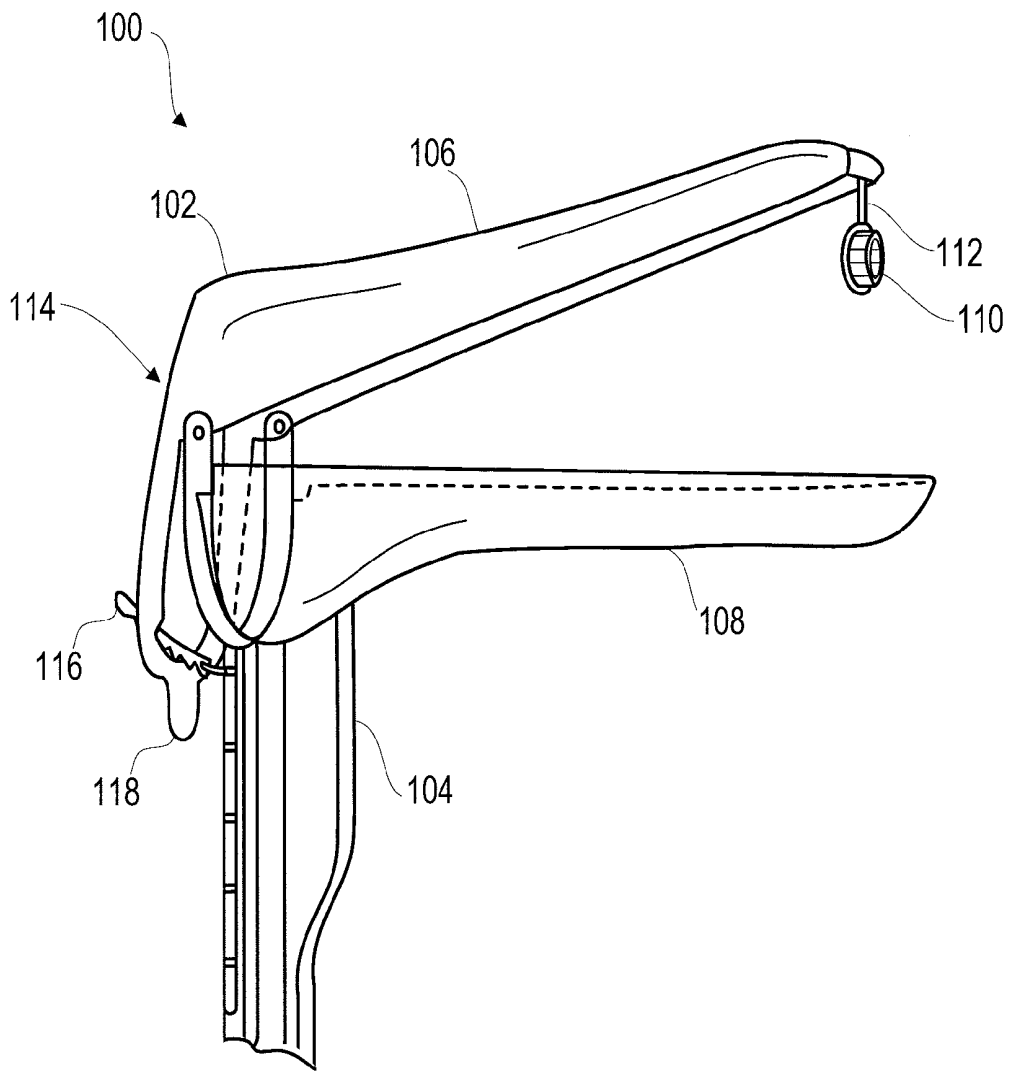
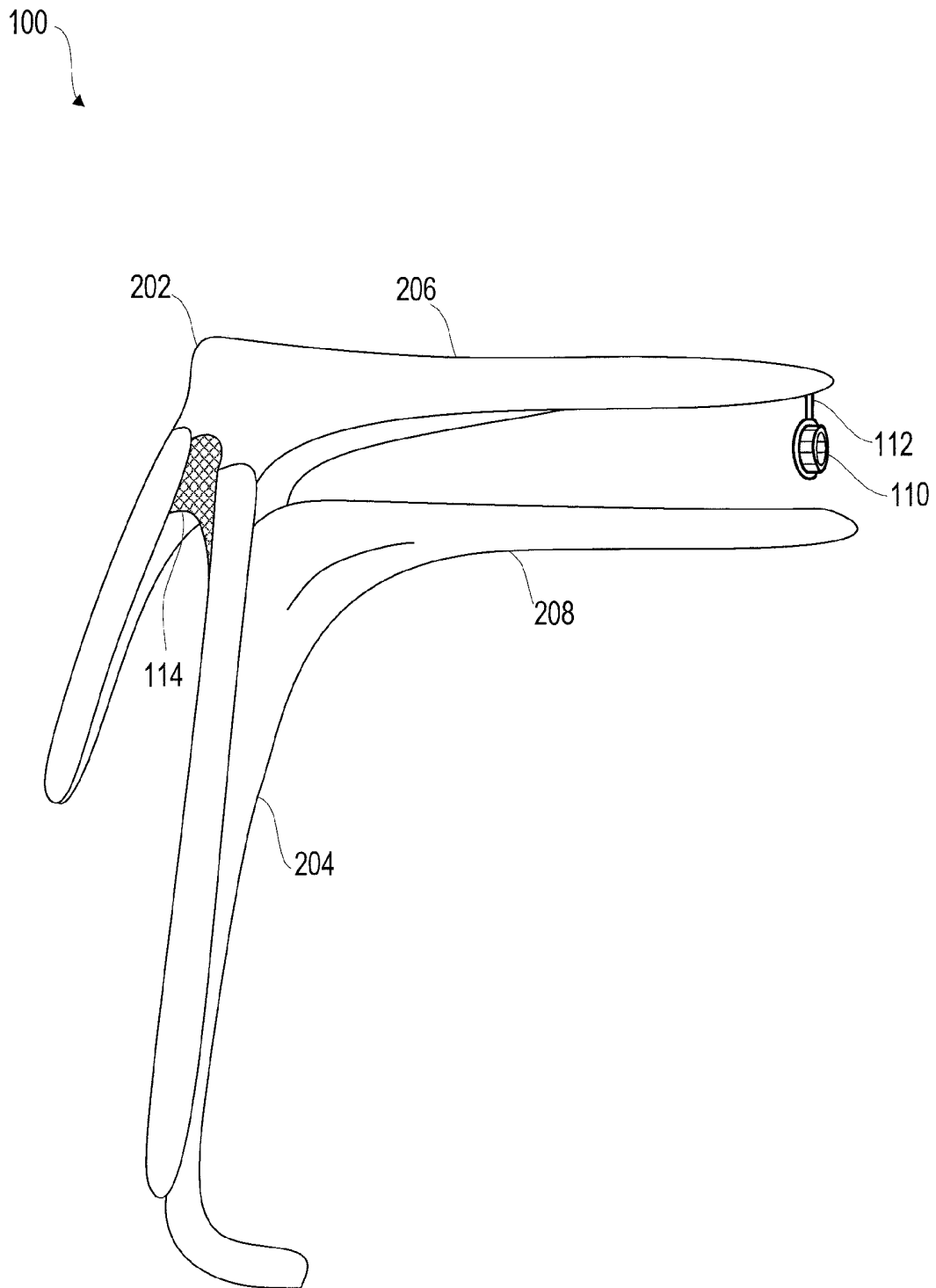

FIG. 2



**FIG. 3**

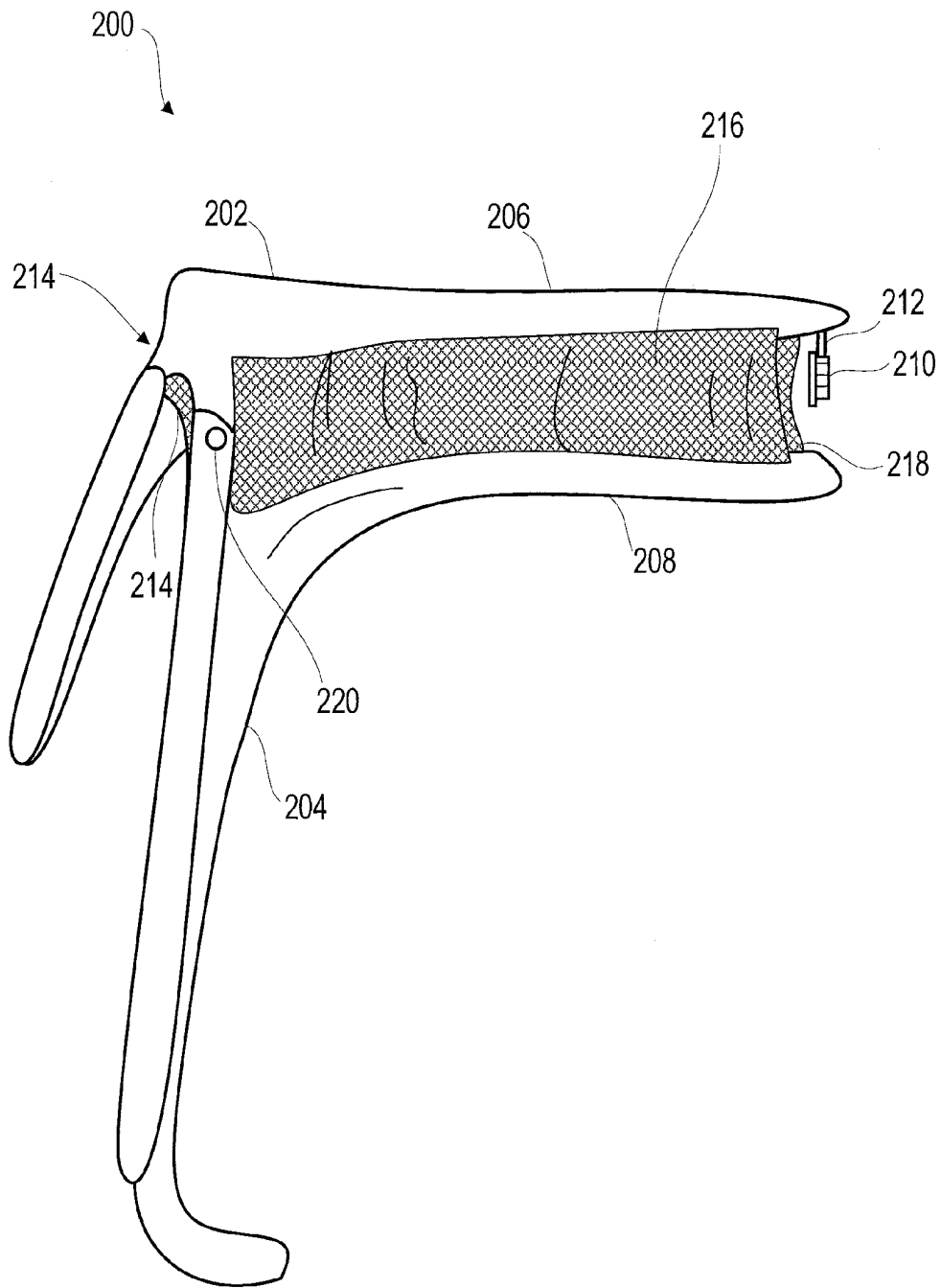

FIG. 4

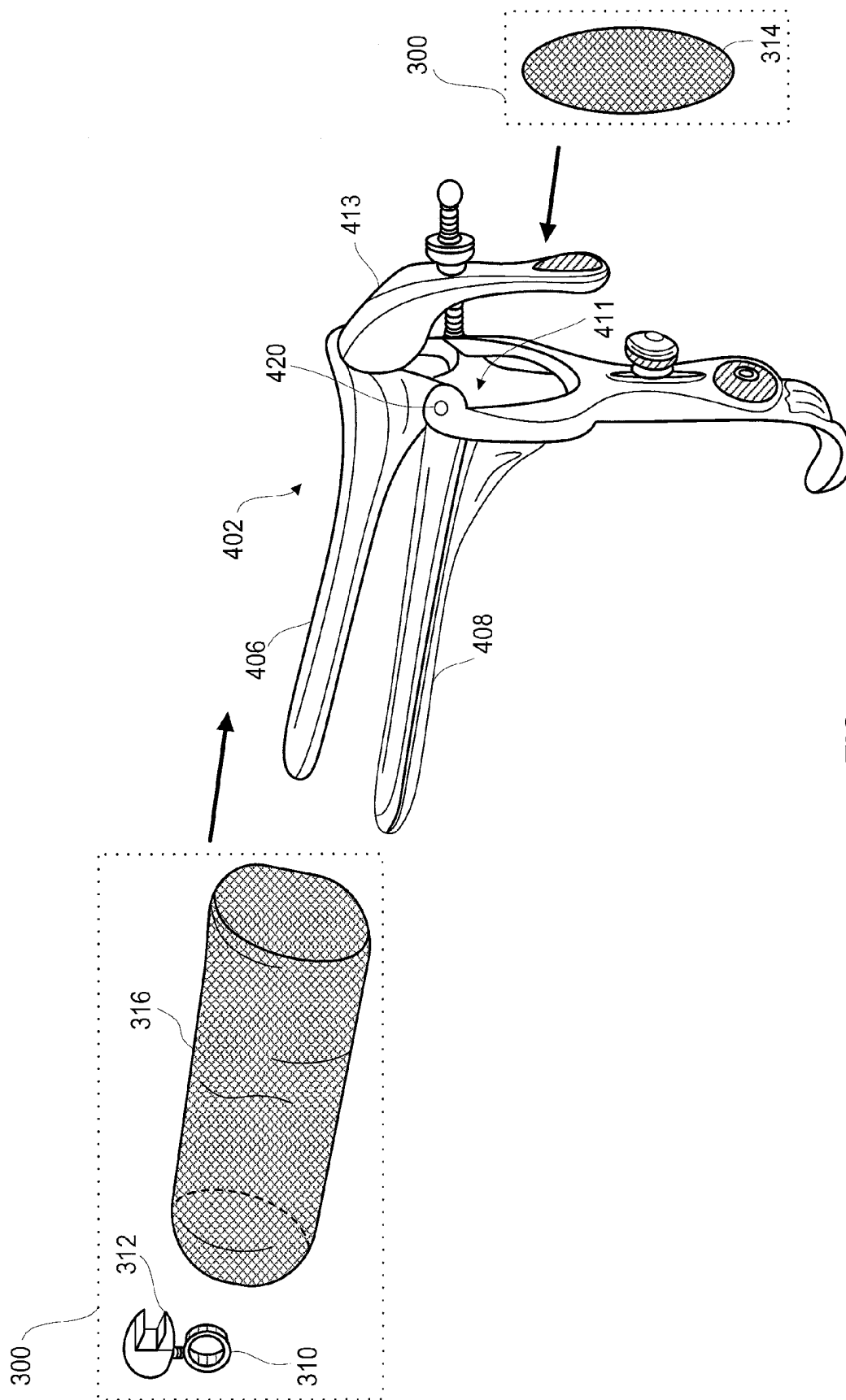

FIG. 5

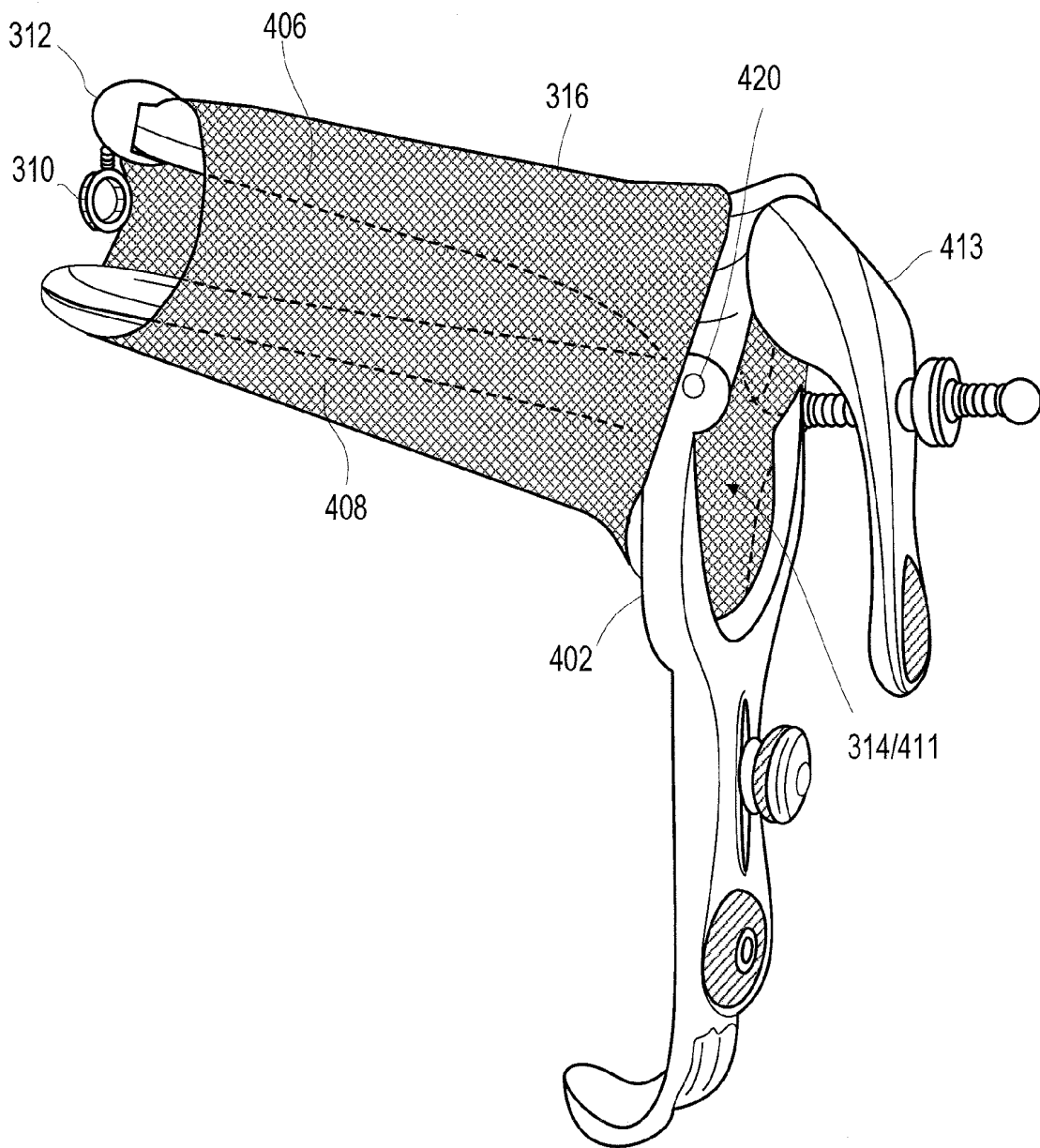

FIG. 6

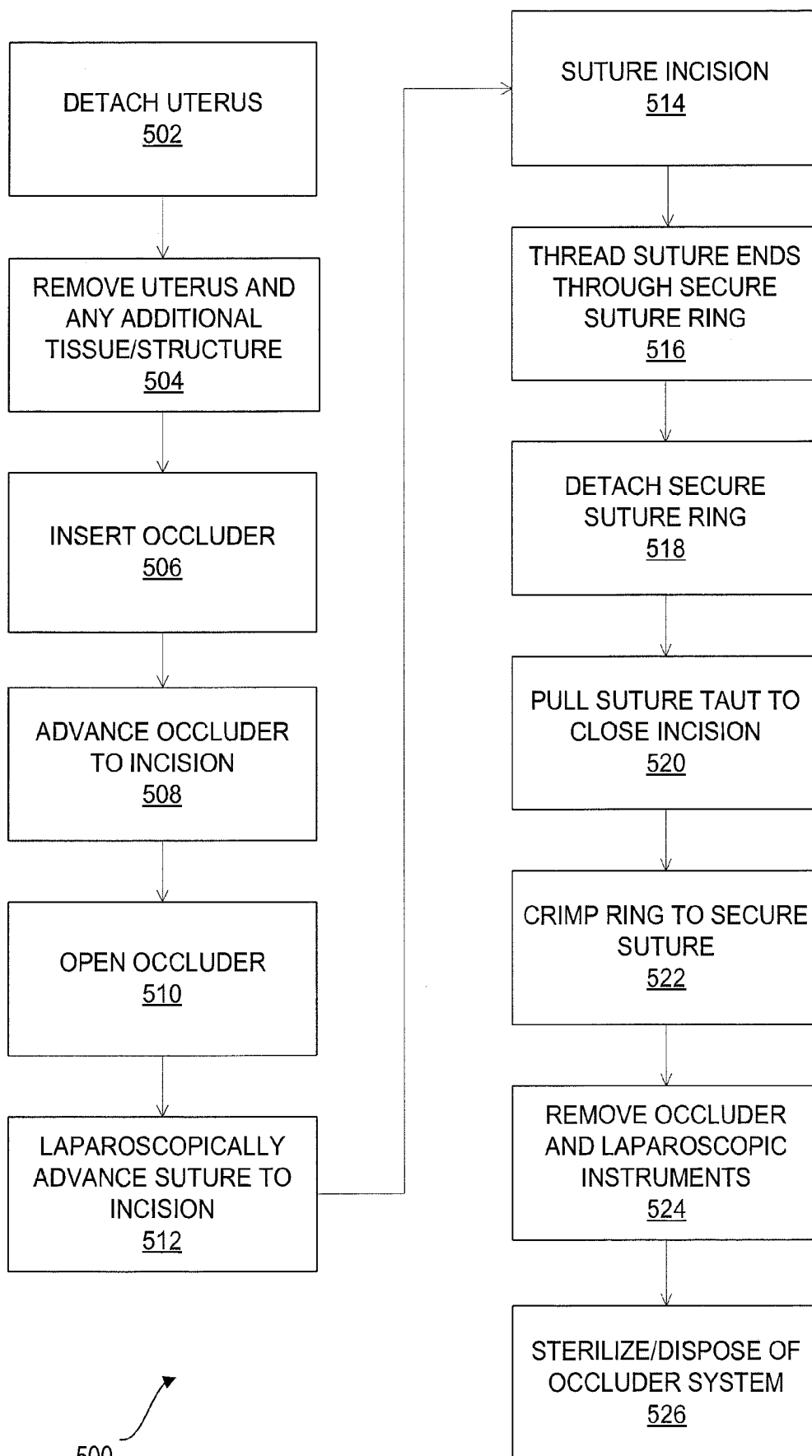

FIG. 7

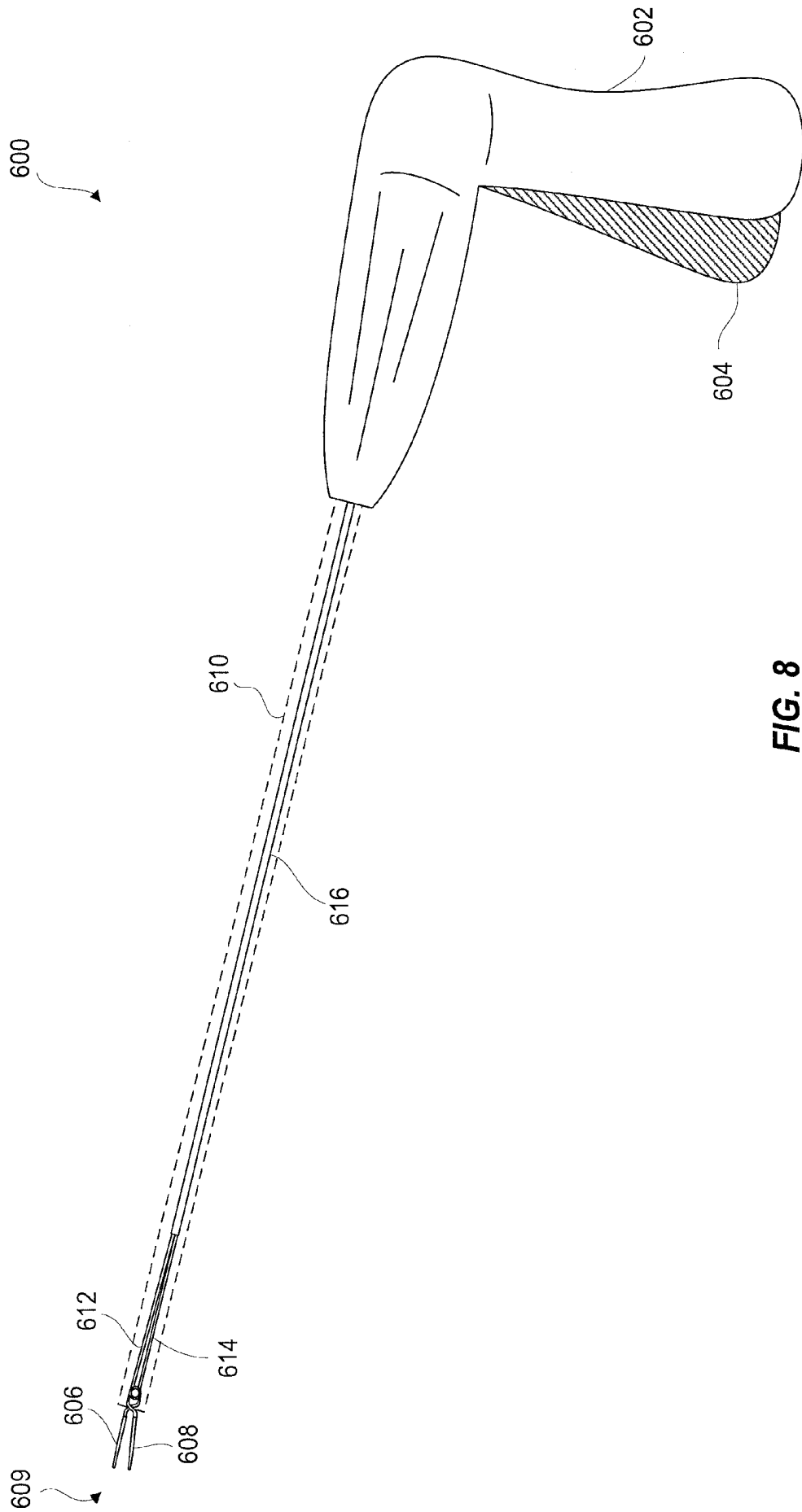

FIG. 8

**VAGINAL CUFF CLOSURE SYSTEMS, AND  
RELATED METHOD FOR KNOT-FREE  
LAPAROSCOPIC HYSTERECTOMY**

RELATED APPLICATIONS

**[0001]** This application claims priority of U.S. Provisional Patent Application No. 61/352,057, filed 7 Jun. 2010 and incorporated herein by reference.

BACKGROUND

**[0002]** Hysterectomy—the surgical removal of the uterus—is the second most common major operation among women in the United States today, second only to cesarean section. According to the National Women’s Health Information Center, over 600,000 American women have a hysterectomy every year, and 1/3 of American women will have a hysterectomy by age 60. The National Women’s Health Information Center. Hysterectomy. Frequently Asked Questions [online], U.S. Department of Health and Human Services Office on Women’s Health, Jul. 1, 2006 [retrieved on May 4, 2010]. Retrieved from the Internet: <URL: <http://www.4women.gov/faq/hysterectomy.htm>>.

**[0003]** Hysterectomy may be performed for a variety of reasons, including removal of reproductive system cancers, prophylactic treatment for those with a strong family history of such cancers, treatment for severe and intractable endometriosis and severe fibroids.

**[0004]** Hysterectomy can be performed in several different ways. Abdominal incision, or laparotomy, is the oldest known and most commonly performed technique in the United States, followed by vaginal hysterectomy, where the surgery is performed through the vaginal canal. Laparoscopic hysterectomy, which has been in conventional practice for just over a decade, allows the uterus to be detached from inside the body by laparoscopic instruments, while the doctor views the uterus, fallopian tubes and ovaries through a camera attached to a telescope. For example, in total laparoscopic hysterectomy (“TLH”), surgically separated tissue (i.e., the uterus and cervix) is removed through an incision at the top of the vaginal canal. The vaginal cuff created during hysterectomy—the portion of the vaginal vault remaining open to the peritoneum—is then closed via laparoscopic suturing. Laparoscopic-assisted supracervical hysterectomy (“LASH”) employs in-situ morcellation to cut the uterus into small pieces that are removed via the laparoscopic ports, sparing the cervix.

**[0005]** Advantages of laparoscopic hysterectomy over abdominal or vaginal hysterectomy include smaller incisions, less patient discomfort, reduced complications, reduced hospital stay of, on average, one day, and a faster return to normal activity (2 weeks for laparoscopic hysterectomy, as compared to 6 weeks or longer for abdominal hysterectomy). Laparoscopic surgery also reduces blood loss, allowing a surgeon to detach blood vessels to the uterus while viewing them through the laparoscope. The uterus can then be removed more easily through the vagina, and with less blood loss.

**[0006]** Despite the clear advantages of laparoscopic hysterectomy, a significant number of hospitals and surgeons do not promote the surgery over alternative methods. Reasons

include reluctance on the part of surgeons to learn laparoscopic techniques and longer operating times associated with laparoscopy.

SUMMARY

**[0007]** One of the more difficult technical aspects of laparoscopic surgery, which is also a contributor to longer operating times, is the tying of intracorporeal knots. Tying knots with laparoscopic instruments inside the body cavity is a difficult and rate-limiting step in many laparoscopic procedures, and mastering this skill involves a long learning curve. The vaginal cuff closure system and related method of knot-free laparoscopic hysterectomy disclosed herein provide a solution to intracorporeal knot tying during laparoscopic hysterectomy.

**[0008]** The term “knot-free”, as used herein, refers to freedom from tying intracorporeal finishing knots during laparoscopic hysterectomy. It will be appreciated that in the described inventions, as well as in conventional laparoscopic surgery, suture having a pre-tied end knot (i.e., an end knot tied before the suture is inserted through a laparoscopic port) may be used to prevent the suture from slipping completely through the tissue to be stitched.

**[0009]** In one embodiment, a vaginal cuff closure system includes a speculum having a closed rear aspect, a secure suture ring and a fastener for removably attaching the secure suture ring with a blade of the speculum.

**[0010]** In one embodiment, a method of knot-free laparoscopic hysterectomy includes laparoscopically detaching a patient’s uterus, removing the uterus and inserting a vaginal cuff closure system into the patient’s vagina. The cuff closure system is advanced until an attached suture securing ring is positioned near the vaginal cuff. The vaginal cuff is laparoscopically sutured, and suture ends threaded through the suture securing ring. The ring is then detached from the fastener, suture is pulled taut to close the vaginal cuff, and the suture securing ring is crimped about the suture, to maintain tension on the suture and closure of the vaginal cuff. Remaining components of the vaginal cuff closure system are then removed from the vagina.

**[0011]** In one embodiment, a laparoscopic instrument for crimping a suture securing ring includes a pair of jaws protruding from the distal end of a shaft. The proximal end of the shaft couples with a handle body having a lever for activating the jaws. Pressing the lever toward the handle body closes the jaws to crimp the suture securing ring and secure in place suture threaded through the ring.

BRIEF DESCRIPTION OF THE DRAWINGS

**[0012]** FIG. 1 is a schematic front view of a vaginal cuff closure system, according to an embodiment.

**[0013]** FIG. 2 is a side view of the system of FIG. 1.

**[0014]** FIG. 3 is a schematic side view of the vaginal cuff closure system of FIGS. 1 and 2, with an alternate speculum body, according to an embodiment.

**[0015]** FIG. 4 is a schematic side view of a vaginal cuff closure system having side seals, according to an embodiment.

**[0016]** FIG. 5 is a partially exploded, side perspective view of a vaginal cuff closure system for fitting with a conventional speculum, according to an embodiment.

**[0017]** FIG. 6 shows the speculum and vaginal cuff closure system of FIG. 5 fitted together.

[0018] FIG. 7 is a flow chart depicting a method for performing knot-free laparoscopic hysterectomy using any of the systems of FIGS. 1-6.

[0019] FIG. 8 is a side view of a laparoscopic instrument for crimping a suture securing ring placed using any of the systems of FIGS. 1-6.

#### DETAILED DESCRIPTION

[0020] FIGS. 1 and 2 show a vaginal cuff closure system 100. System 100, and other systems described herein, may alternately be referred to herein as “vaginal occluders”. System 100 includes a speculum 102 having a handle 104 and upper and lower blades 106 and 108. In one embodiment, a suture securing ring 110 (also referred to hereinafter as a secure suture ring 110) removably attaches with a fastener 112 that is formed with or attached to upper blade 106. For example, fastener 112 may be a hook element extruded or otherwise formed with upper blade 106, upon which secure suture ring 110 hangs. Fastener 112 may optionally be a clamp element attached with upper blade 106 and (removably) with secure suture ring 110, or any other means of removably attaching secure suture ring 110 with upper blade 106.

[0021] Speculum 102 differs from a conventional vaginal speculum in that the rear aspect (that is, the aspect distal to the patient when the speculum is inserted into the vagina) is closed. Sides of speculum 102 (not shown, but for example between blades 106 and 108) are also at least partially closed. The rear aspect and sides of a conventional vaginal speculum are open, to allow a physician or clinician to view and access the vagina and cervix (e.g., for examination and swabbing) when the speculum is inserted. In one aspect, speculum 102 is manufactured with a closed rear surface 114 between upper and lower blades 106 and 108, and with sealed lateral surfaces A and B between upper and lower blades 106 and 108 (see also FIGS. 4-6 and description thereof for further details regarding closed side surfaces).

[0022] Optionally, surface 114 is provided by a separate seal (hereinafter, “seal 114”, see also FIG. 3) that is applied to the rear aspect of speculum 102. Seal 114 may be applied to the body of speculum 102 between blades 106 and 108, or seal 114 may overlap blades 106 and 108, either inside or outside of the blades (e.g., mounted with and overlapping inner or outer blade surfaces). Where seal 114 is applied as a step in manufacturing speculum 102, a permanent adhesive may be used. Examples include glue and a permanent double-sided tape or foam tape. Optionally, a reusable adhesive (e.g., reusable silicone adhesive) may be used to secure seal 114 with speculum 102. Sealed side surfaces A and B may likewise be provided by separate seals that can be affixed and removed by a user, when speculum 102 is not manufactured with sealed sides.

[0023] In one aspect, seal 114 is sufficiently elastic to allow for opening and closure of blades 106 and 108. Seal 114 is for example made with rubber, flexible plastic, an elastic fabric or any other material having sufficient elasticity to allow blades 106 and 108 their full range of movement when seal 114 attaches with speculum 102.

[0024] Seal 114 prevents gas used to inflate the patient's abdomen during laparoscopic surgery (e.g., CO<sub>2</sub>) from escaping through the vagina. Thus, occluder 100 may be inserted and opened without compromising an intraabdominal work area. Lateral seals A and B enhance maintenance of the work

area by flattening against the vaginal walls when speculum 102 is inserted into the vagina, to further prevent escape of surgical gas.

[0025] Secure suture ring 110 is a crimpable ring made of biocompatible material (e.g., biocompatible metal). As noted above, secure suture ring 110 removably attaches to fastener 112. Secure suture ring 110 for example includes a collar portion for preventing slippage of the ring and/or for facilitating grasping of ring 110 with laparoscopic tools.

[0026] In one example of use, a surgeon performs laparoscopic hysterectomy and removes a patient's uterus through an incision at the top of the vagina. After removal of the uterus, vaginal occluder 100 is inserted blades-first into the vagina, with secure suture ring 110 removably attached to fastener 112. Occluder 100 is advanced until ring 110 is proximate the vaginal incision (e.g., when viewed laparoscopically), and blades 106 and 108 are opened to a desired width and secured in place with locking mechanisms 116 and 118. Mechanisms 166 and 118 are shown in FIG. 2 as a notched catch and thumb-lever element, respectively, although alternate locking mechanisms may be used.

[0027] Once vaginal occluder 100 is in place, the surgeon sutures the vaginal incision. In one aspect, loop o-vicryl is used to suture the vaginal cuff in running fashion, starting at opposing lateral edges of the cuff and proceeding medially. In one example, a loop suture is used to close the incision by starting laterally, passing the suture through the anterior and then the posterior part of the incision and then back through the loop, and tightened to anchor the suture at the lateral aspect of the incision. The incision is sewn shut from lateral to medial, stopping in the midline. A second strand of suture and a second needle are used to sew the other side of the incision shut in like manner, lateral to medial. Once suturing is complete, free suture ends are passed through secure suture ring 110, and a laparoscopic instrument is used to release ring 110 from fastener 112. Tension is adjusted on the suture as desired. When the suture is sufficiently tight, the surgeon uses a laparoscopic instrument to crimp secure suture ring 110 about the suture, securing the suture in place. Blades 106 and 108 are returned to fully closed position, and system 100 is removed from the vagina.

[0028] Secure suture ring 110 holds the suture in place and at a desired tension without requiring any finishing knots. System 100 therefore allows a surgeon to perform laparoscopic hysterectomy without tying intracorporeal knots, thereby simplifying the procedure and speeding its learning curve while reducing total surgery time. Reduced surgery time leads to reduced anesthesia, both of which in turn translate to reduced costs associated with laparoscopic hysterectomy.

[0029] Components 102-108 and 112-114 of vaginal cuff closure system/occluder 100 may be disposable, or they may be sterilized in an autoclave for re-use.

[0030] FIG. 3 shows vaginal occluder 100 with an alternate speculum body 202. It will be appreciated that occluder 100 may incorporate any known speculum type, including Cusco, Grave's, Pederson, Auvard's, Eastman, Sims, Doyen, duck-bill, lateral screw type, push-type and middle screw type. Speculum 202 includes a handle 204 with upper and lower blades 206 and 208. Seal 114 closes the rear of speculum 202 and fastener 112 attaches with speculum 202 and ring 110, as is described above with respect to speculum 102.

[0031] FIG. 4 shows a vaginal cuff closure system 200, including additional seals for closing the sides of speculum

**202** (described above) between blades **206** and **208**. It will be appreciated that side seals such as those now described may also complement system **100** (also described above).

[**0032**] System/vaginal occluder **200** includes a pair of side seals **216** and **218**, for closing the sides of speculum **202**. It will be appreciated that speculum **202** is shown in simplified form, with locking mechanisms removed for clarity of illustration and to provide a better view to an end seal **214**. End seal **214** is similar to seal **114**, described above. When speculum **202** is inserted into the vagina, side seals **216** and **218** and end seal **214** prevent gas used to distend the abdomen from escaping through the vagina. Side seals **216** and **218** are sufficiently flexible to allow blades **206** and **208** to open and close through their full range of movement. In one aspect, side seals **216** and **218** are permanent or removable rubber latex (or latex-free rubber) sheets affixed between blades **206** and **208**, and optionally extending beyond a pivot point **220** for the blades and/or overlapping a portion of handle **204**. Side seals **216** and **218** may also be made of flexible plastic, an elastic fabric or any other material having sufficient elasticity to permit full movement of blades **206** and **208**.

[**0033**] FIG. 5 is a partially exploded drawing showing a vaginal cuff closure system **300**. For ease of illustration, components of system **300** are shown enclosed by dotted boxes. System **300** may be retrofitted to a separate speculum **402**, for example, one already owned by a surgeon, hospital or clinic.

[**0034**] System **300** includes a secure suture ring **310** for removably attaching with a fastener **312**. Like ring **110**, ring **310** may include a collar portion for facilitating grasping with a laparoscopic tool, and/or for preventing slippage of ring **110**. Fastener **312** is illustratively shown as a clamp for clamping with a top blade **406** of speculum **402**; however, alternate fasteners **312** are within the scope hereof.

[**0035**] A flexible sealing sleeve **316** slides over blades **406** and **408** of speculum **402**. Sealing sleeve **316** is sufficiently elastic to permit full opening of blades **406** and **408** while maintaining a seal over the open sides between the blades (e.g., that appear or increase when speculum **402** is activated to open blades **406** and **408**). A similarly elastic end seal **314** attaches with a rear aspect of speculum **400**. In one aspect, end seal **314** includes an adhesive backing for fitting about a rear opening **411** of speculum **402**, to seal the opening.

[**0036**] Sleeve **316** and end seal **314** are similar in composition and function to side seals **316** and **218** and end seals **114** and **214**, described above. When sleeve **316** and seal **314** are applied to speculum **400** and speculum **402** is inserted into the vaginal canal, sleeve **316** and seal **314** create an air-tight occlusion of the vagina, preventing escape of cavity-inflating CO<sub>2</sub> gas.

[**0037**] In one aspect, a release liner is removed from a speculum-contact side (not shown) of end seal **314** to expose an adhesive. Seal **314** is applied over rear opening **411**, to seal the opening. The perimeter of seal **314** may for example be pressed to speculum **402**, around opening **411**, including pressing seal **314** to the base of a thumb lever **413** (or other control or locking structure) to insure that opening **411** is fully covered by seal **314**. It will be appreciated that seal **314** is shown having an oval shape for illustrative purposes only, and may instead be shaped to fit with contours of an existing speculum type (e.g., Grave's, Cusco or any other conventional speculum). For example, seal **314** may be provided with a notch or shaped cut-out to fit about the base of thumb lever **413**.

[**0038**] Alternately, seal **314** may be applied from within speculum **402** (i.e., from between blades **406** and **408**) and secured to inner aspects of blades **406** and **408** and/or the speculum body. Sleeve **316** is advanced over blades **406** and **408** until sufficient coverage is achieved. For example, sleeve **316** may be advanced up to or slightly covering a blade pivot point **420**. Once sleeve **316** is in place, fastener **312** is secured at the front of blade **420** (see, e.g., fastener **112** position on blade **106**, FIG. 2). Ring **310** may be placed with fastener **312** before or after attachment of fastener **312** and blade **406**. Likewise, the other components of system **300** need not necessarily be fitted to speculum **402** in the order described above. FIG. 6 shows speculum **402** fitted with system **300**.

[**0039**] FIG. 7 illustrates a method **500** for performing knot-free laparoscopic hysterectomy using any of the vaginal occluders/systems described above. FIG. 7 assumes that, if provided as a kit for fitting with a preexisting speculum, the vaginal occluder is assembled prior to commencement of surgery. However, it will be understood that the occluder may alternately be assembled during surgery, before it is needed (i.e., by an assistant). It will also be appreciated that steps of laparoscopic hysterectomy prior to uterine detachment are not described, nor is uterine detachment and removal elaborated below, as these steps are known in the art of gynecological surgery.

[**0040**] In step **502**, the uterus is surgically detached using laparoscopic instruments. The uterus and any additional tissue to be removed, such as the cervix and fallopian tubes, are removed through the vagina, in step **504**. Following removal, a vaginal occluder is inserted into the vagina and advanced until an attached suture securing ring is proximate the incision in the vagina (vaginal cuff), in steps **506** and **508**. The occluder blades are opened as desired, in step **510**. Suture is laparoscopically advanced to the vaginal cuff, in step **512**, and the cuff is sutured in step **514**. Suture ends are threaded through the occluder's suture securing ring, in step **516**, and the ring is removed from the fastener holding it to the speculum portion of the occluder, in step **518**. Suture is pulled taut to close the vaginal cuff, in step **520**. The suture securing ring is then crimped shut over the suture in step **522**, to hold the suture securely in place and maintain the desired tautness on the suture, keeping the vaginal cuff closed.

[**0041**] After the vaginal cuff is closed, the occluder is removed from the vagina, and laparoscopic instruments are removed from the abdominal cavity, in step **524**. The occluder is disposed of or sterilized in step **526**, depending upon whether the occluder is fully disposable or some or all components of the occluder are re-usable.

[**0042**] In one example of steps **506-526**, system/occluder **200** is inserted in the vagina and advanced until the surgeon visually confirms that secure suture ring **210** lies just inside the peritoneum. Although not illustrated in FIG. 4, fastener **212** for example includes a thin wire or stiff filament for holding ring **210** slightly forward of speculum **202**, such that ring **210** may be advanced just beyond the vaginal cuff and into the peritoneum while speculum **202** and associated components of system **200** remain within the vagina.

[**0043**] Once in place, occluder **200** is opened as desired by the surgeon, for example, to provide additional space for suturing the vaginal cuff. Suture is laparoscopically advanced to the vaginal cuff, and the cuff is then sutured in running fashion starting at angles/sides of the cuff and proceeding to the midline. In one aspect, a loop suture is used to close the incision by starting laterally, passing the suture through the

tissue border anterior-to-posterior. Suture is then passed back through the loop and tightened to anchor the suture at the lateral aspect of the incision. The incision is sewn shut from lateral to medial, stopping in the midline. A second strand of suture and a second needle are used to sew the other side of the incision shut, again, lateral to medial. Loose suture ends are then threaded through secure suture ring **210** and ring **210** is detached from fastener **212** using laparoscopic instruments. The suture is pulled taut to close the vaginal cuff, and ring **210** is crimped shut from the abdominal side of the vaginal vault, using a laparoscopic instrument. Occluder **200** is then removed from the vagina without disrupting cuff borders and suture holding the cuff together, as the cuff is sewn shut from the abdominal side while occluder **200** remains in the vagina. Laparoscopic instruments are also removed from the patient's body, and all laparoscopic ports are closed. Occluder system **200** is disposed of or sterilized, as appropriate.

[0044] In another example of method **700**, system **300** is fitted with re-usable speculum **402**. Following surgery, speculum **402** is sterilized in an autoclave and system **300** parts are sterilized or disposed of as appropriate, in step **526**.

[0045] FIG. **8** shows a laparoscopic crimping instrument **600** for crimping secure suture ring **110**, **210** or **310** of system **100**, **200** or **300**, respectively. Instrument **600** includes a handle **602** having a lever **604** for activating jaws **606** and **608**, which protrude from a distal end **609** of a shaft **610** coupled with handle **602**. In one aspect, pressing lever **604** into/towards handle **602** activates wires **612-616** within shaft **610** to effect closure of jaws **606** and **608**; however, it will be appreciated that alternate methods of jaw closure known in the art of laparoscopic surgery may also be implemented with instrument **600**. Shaft **610** is shown in dotted outline for purposes of illustrating wires **612-614** therein. In one aspect, shaft **610** is approximately 15 inches long.

[0046] In practice, distal end **609** is inserted through a laparoscopic trocar (not shown) and instrument **600** is advanced until jaws **606** and **608** contact opposing sides of secure suture ring **110/210/310**. Once jaws **606** and **608** grasp ring **110/210/310**, lever **604** is pulled inward to close jaws **606** and **608** and crimp secure suture ring **110/210/310** about suture threaded therethrough. Releasing lever **604** opens jaws **606** and **608**, freeing the crimped ring from the jaws. After proper closure of ring **110/210/310** is visually confirmed by the surgeon, instrument **600** is withdrawn through the trocar.

[0047] While the present invention has been described above, it should be clear that many changes and modifications may be made to the cuff closure system and associated method of knot-free laparoscopic hysterectomy, without departing from the spirit and scope of this invention. For example, all or select parts of the system may be disposable or re-usable. Additionally, system parts shown in one figure may be combined with parts shown in other figures, without departing from the scope hereof. Likewise, although described and shown as being attached with an upper speculum blade, the fasteners and rings disclosed herein may also be attached elsewhere with a speculum (i.e., with a lower blade).

What is claimed is:

1. A vaginal cuff closure system, comprising:

a speculum having a closed rear aspect;

a secure suture ring; and

a fastener for removably attaching the secure suture ring with a blade of the speculum.

2. The system of claim **1**, further comprising a pair of flexible side seals, the side seals and the closed rear aspect providing an airtight chamber between the speculum blades when the speculum is inserted into a patient's vagina, to prevent escape of body-inflating surgical gas through the vagina.

3. The system of claim **1**, further comprising a flexible sealing sleeve for fitting over the speculum blades, the sealing sleeve and the closed rear aspect providing an airtight chamber between the speculum blades when the speculum is inserted into a patient's vagina, to prevent escape of body-inflating surgical gas through the vagina.

4. The system of claim **1**, the closed rear aspect provided by an end seal for fitting over a rear opening of the speculum.

5. The system of claim **4**, further comprising (a) a flexible sealing sleeve for fitting over the speculum blades or (b) a pair of flexible side seals for sealing left and right sides of the speculum between upper and lower speculum blades, one or more of the end seal, the flexible sealing sleeve and the flexible side seals including an adhesive for attaching the end seal, sealing sleeve or side seals with the speculum.

6. The system of claim **5**, the adhesive selected from the group of a re-usable adhesive, a foam tape, a double-sided tape and a glue.

7. The system of claim **1**, the secure suture ring comprising a biocompatible material and having a tensile strength sufficient to grasp and secure suture at a desired position and tension when crimped about the suture.

8. The system of claim **7**, the secure suture ring comprising a textured internal surface to facilitate grasping of the suture when the ring is crimped about the suture.

9. A method of knot-free laparoscopic hysterectomy, comprising the steps of

laparoscopically detaching a patient's uterus;

removing the uterus;

inserting a vaginal cuff closure system into the patient's vagina;

advancing the cuff closure system such that an attached suture securing ring is accessible at the vaginal cuff;

laparoscopically suturing the vaginal cuff;

threading suture ends through the suture securing ring;

detaching the suture securing ring from a speculum of the vaginal cuff closure system;

pulling the suture taut to close the vaginal cuff;

crimping the suture securing ring about the suture, to maintain tension on the suture and closure of the vaginal cuff; and

removing remaining elements of the vaginal cuff closure system from the vagina.

10. The method of claim **9**, wherein removing remaining elements of the vaginal cuff closure system comprises removing the speculum and attached fastener and seals.

11. A laparoscopic instrument for crimping a suture securing ring, comprising:

a pair of jaws protruding from the distal end of a shaft; the proximal end of the shaft coupled with a handle body having a lever for activating the jaws;

wherein pressing the lever toward the handle body closes the jaws to crimp the suture securing ring and secure in place suture threaded through the ring.

12. The instrument of claim **11**, the jaws coupled with the lever via one or more wires running from the jaws to the handle body within the shaft.

**13.** A vaginal cuff closure system for retrofit assembly with a speculum, comprising:

a secure suture ring;  
a fastener for removably fitting the secure suture ring with a blade of the speculum;  
an end seal for sealing a rear aspect of the speculum; and  
one or more side sealing mechanisms for sealing left and right sides of the speculum, between upper and lower blades of the speculum;

wherein the end seal and the one or more side sealing mechanisms provide an airtight chamber between the speculum blades when the speculum is inserted into a patient's vagina.

**14.** The system of claim **13**, the one or more side sealing mechanisms selected from the group consisting of a flexible sealing sleeve for fitting over the speculum blades, and a pair of flexible side seals.

**15.** The system of claim **13**, the end seal and the one or more side sealing mechanisms comprising an adhesive for securing the end seal and the side sealing mechanisms with the speculum.

**16.** The system of claim **15**, the adhesive selected from the group of a re-usable adhesive, a foam tape, a double-sided tape and a glue.

**17.** The system of claim **13**, the secure suture ring comprising a biocompatible material and having a tensile strength sufficient to grasp and secure suture at a desired position and tension when crimped about the suture.

**18.** The system of claim **17**, the secure suture ring comprising a textured internal surface to facilitate grasping of the suture when the ring is crimped about the suture.

\* \* \* \* \*

专利名称(译)	阴道袖口闭合系统及无结腹腔镜子宫切除术的相关方法		
公开(公告)号	<a href="#">US20110301424A1</a>	公开(公告)日	2011-12-08
申请号	US13/035729	申请日	2011-02-25
[标]申请(专利权)人(译)	JAMES的Steigerwald J		
申请(专利权)人(译)	JAMES的Steigerwald J.		
当前申请(专利权)人(译)	JAMES的Steigerwald J.		
[标]发明人	STEIGERWALD JAMES J		
发明人	STEIGERWALD, JAMES J.		
IPC分类号	A61B1/32		
CPC分类号	A61B1/303 A61B1/32 A61B17/0482 A61B17/0487 A61B2017/3419 A61B2017/00429 A61B2017/00477 A61B2017/0488 A61B17/4241		
优先权	61/352057 2010-06-07 US		
其他公开文献	US8652035		
外部链接	<a href="#">Espacenet</a> <a href="#">USPTO</a>		

摘要(译)

一种阴道箍闭合系统，包括具有封闭的后部的窥器，安全的缝合环和用于将固定的缝合环与窥器的刀片可拆卸地连接的紧固件。还公开了一种在无结腹腔镜子宫切除术中使用闭合系统的相关方法。

