



US 20080132890A1

(19) **United States**
(12) **Patent Application Publication**
Woloszko et al.

(10) **Pub. No.: US 2008/0132890 A1**
(43) **Pub. Date: Jun. 5, 2008**

(54) **ELECTROSURGICAL APPARATUS AND METHODS FOR LAPAROSCOPY**

(75) Inventors: **Jean Woloszko**, Austin, TX (US);
Maria B. Ellsberry, Fremont, CA (US)

Correspondence Address:
ARTHROCARE CORPORATION
7500 Rialto Boulevard, Building Two, Suite 100
Austin, TX 78735-8532

(73) Assignee: **ArthroCare Corporation**, Austin, TX (US)

(21) Appl. No.: **12/031,771**

(22) Filed: **Feb. 15, 2008**

Related U.S. Application Data

(60) Division of application No. 10/365,759, filed on Feb. 14, 2003, now Pat. No. 7,331,957, which is a continuation-in-part of application No. 09/766,168, filed on Jan. 19, 2001, now Pat. No. 6,589,237, which is a continuation-in-part of application No. 09/197,013, filed on Nov. 20, 1998, now Pat. No. 6,296,638, which is a continuation-in-part of application No. 09/010,382, filed on Jan. 21, 1998, now Pat. No. 6,190,381, which is a continuation-in-part of application No. 08/990,374, filed on Dec. 15, 1997, now Pat. No. 6,109,268, which is a continuation-in-part of application No. 08/485,219, filed on Jun. 7, 1995, now Pat.

No. 5,697,281, which is a continuation-in-part of application No. 08/446,767, filed on Jun. 2, 1995, now Pat. No. 5,697,909, filed as application No. PCT/US94/05168 on May 10, 1994, which is a continuation-in-part of application No. 08/059,681, filed on May 10, 1993, now abandoned, which is a continuation-in-part of application No. 07/958,977, filed on Oct. 9, 1992, now Pat. No. 5,366,443, which is a continuation-in-part of application No. 07/817,575, filed on Jan. 7, 1992, now abandoned.

(60) Provisional application No. 60/233,345, filed on Sep. 18, 2000, provisional application No. 60/210,567, filed on Jun. 9, 2000.

Publication Classification

(51) **Int. Cl.**
A61B 18/14 (2006.01)
(52) **U.S. Cl.** **606/41**

(57) **ABSTRACT**

Electrosurgical methods and apparatus for treating tissue at a target site of a patient. An electrosurgical instrument includes a shaft, having a shaft distal end and a shaft proximal end, and an electrode assembly disposed at the shaft distal end. The electrode assembly includes at least one active electrode disposed on an electrode support. The instrument is adapted for coupling to a high frequency power supply or electrosurgical generator. Each active electrode is adapted for removing tissue from a target site and/or for localized coagulation of the target tissue. In one embodiment, the instrument is adapted for laparoscopic procedures.

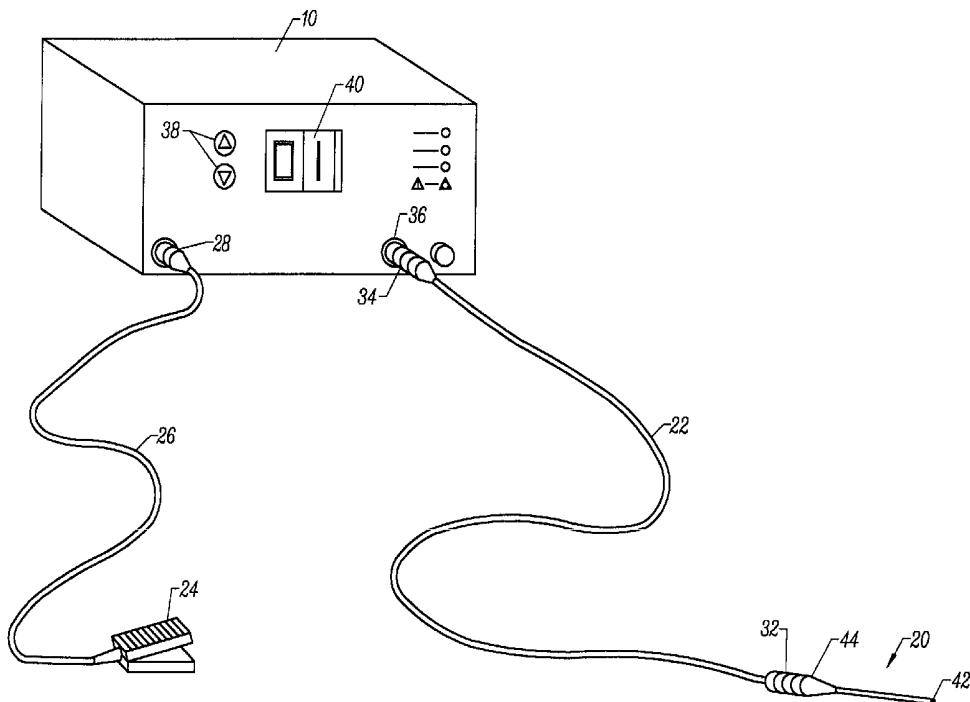

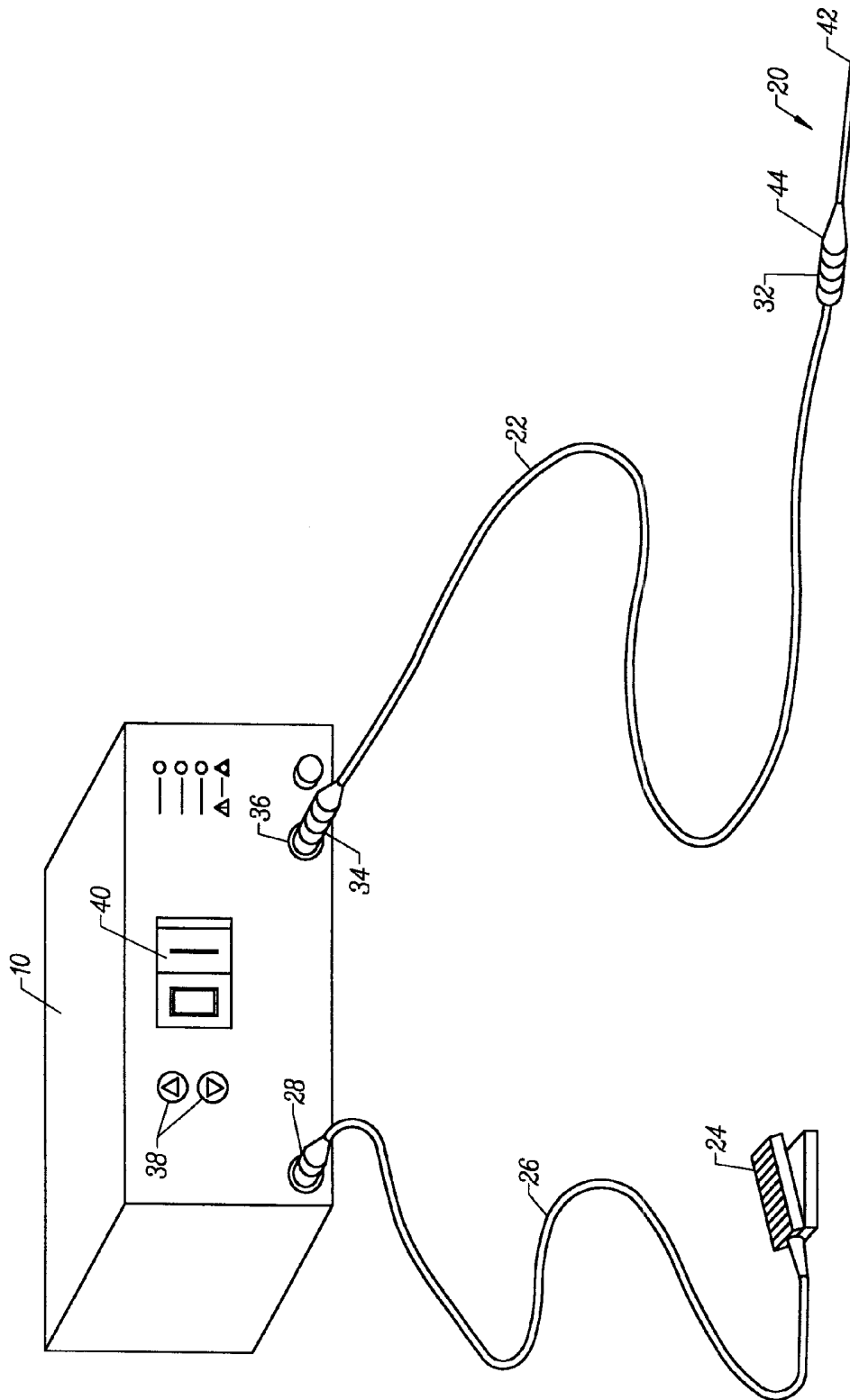
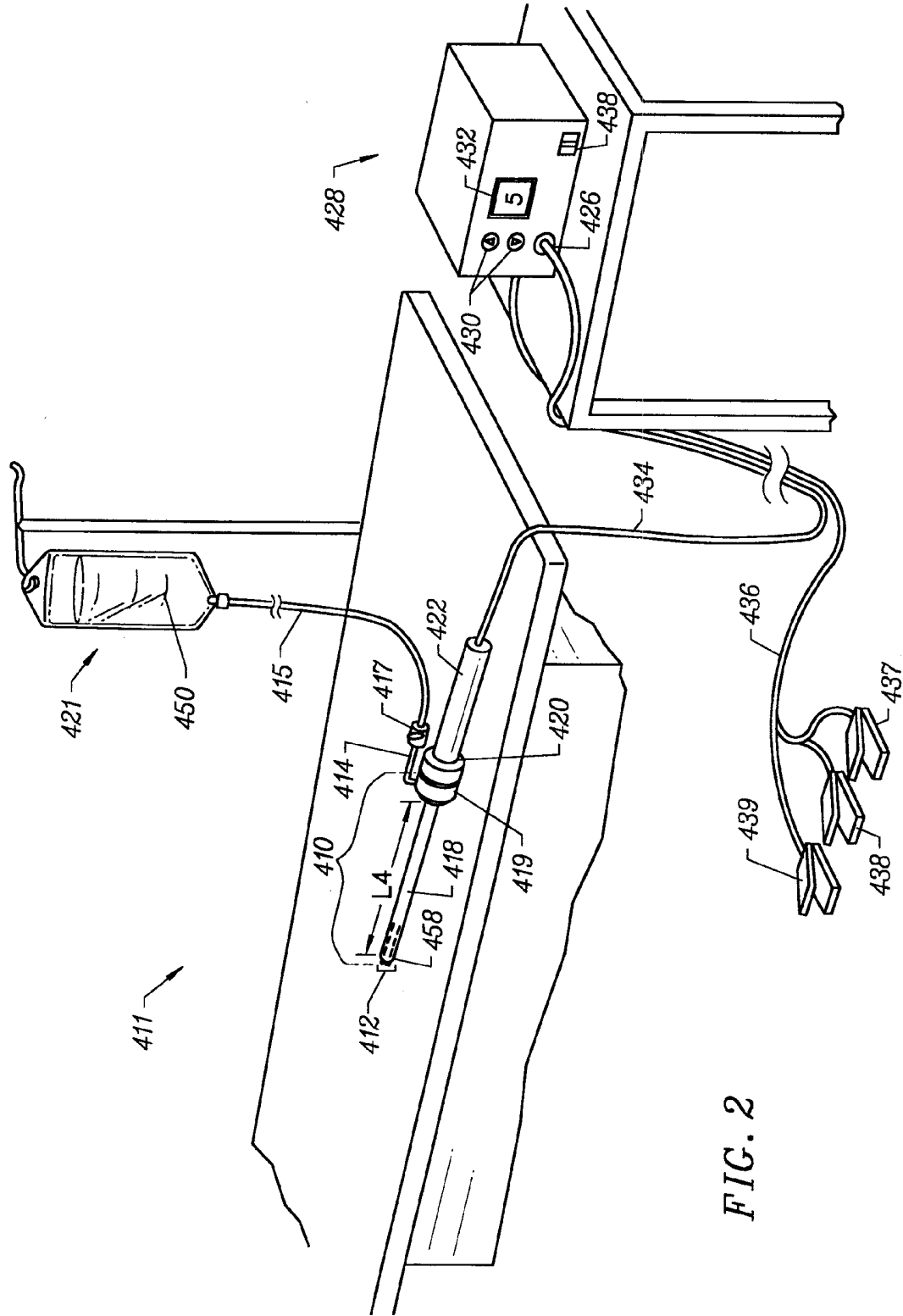

FIG. 1



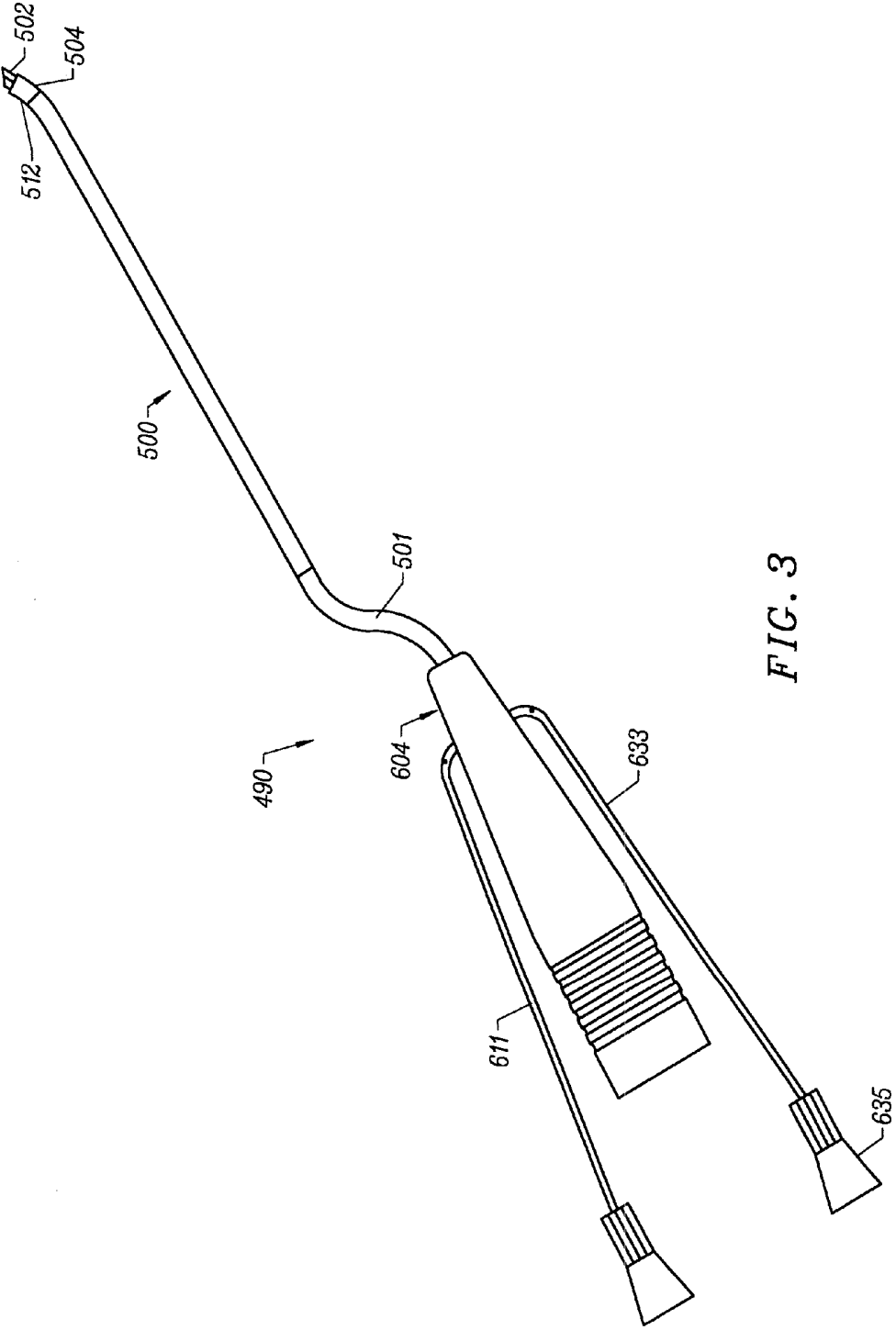
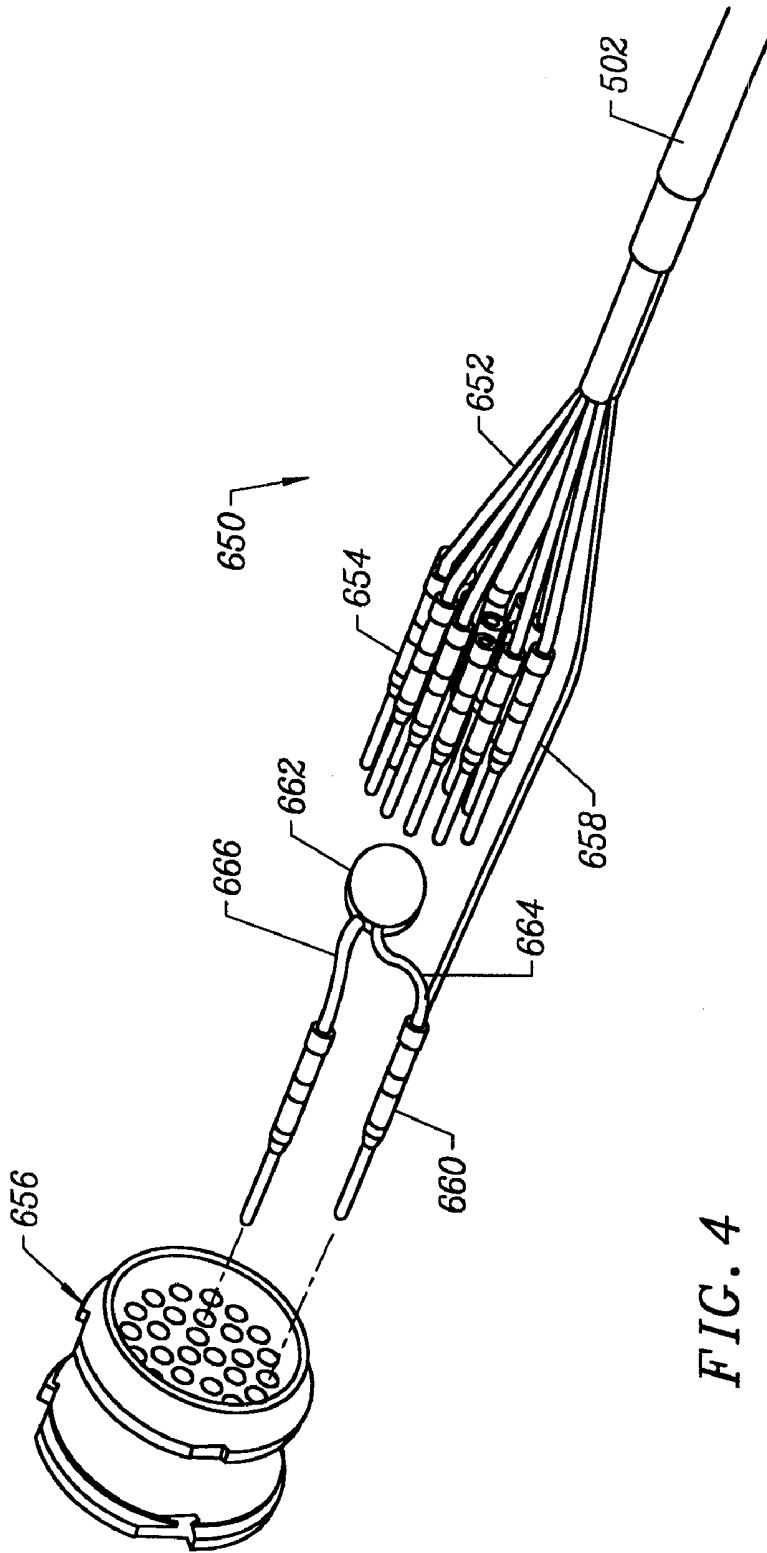

FIG. 3



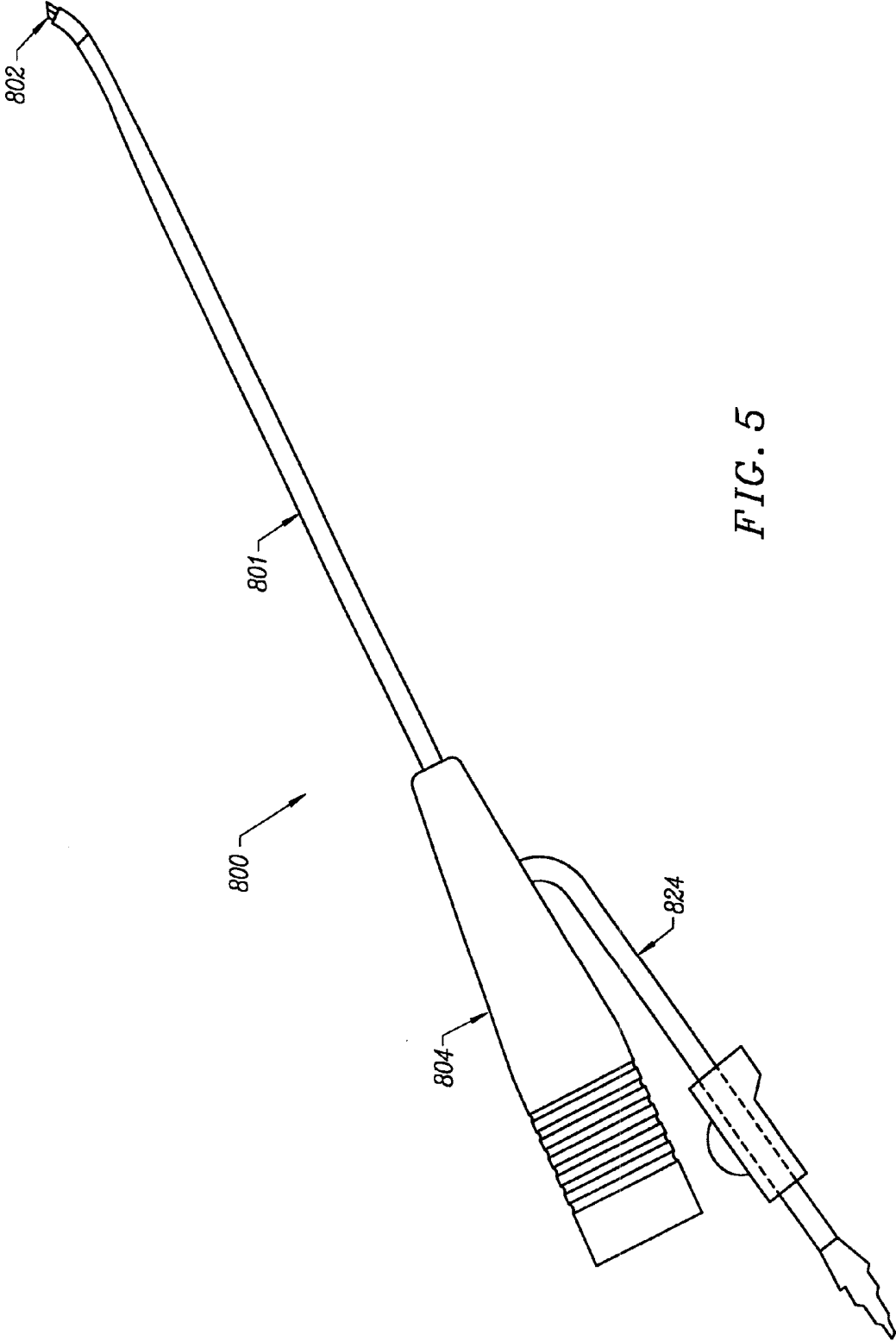

FIG. 5

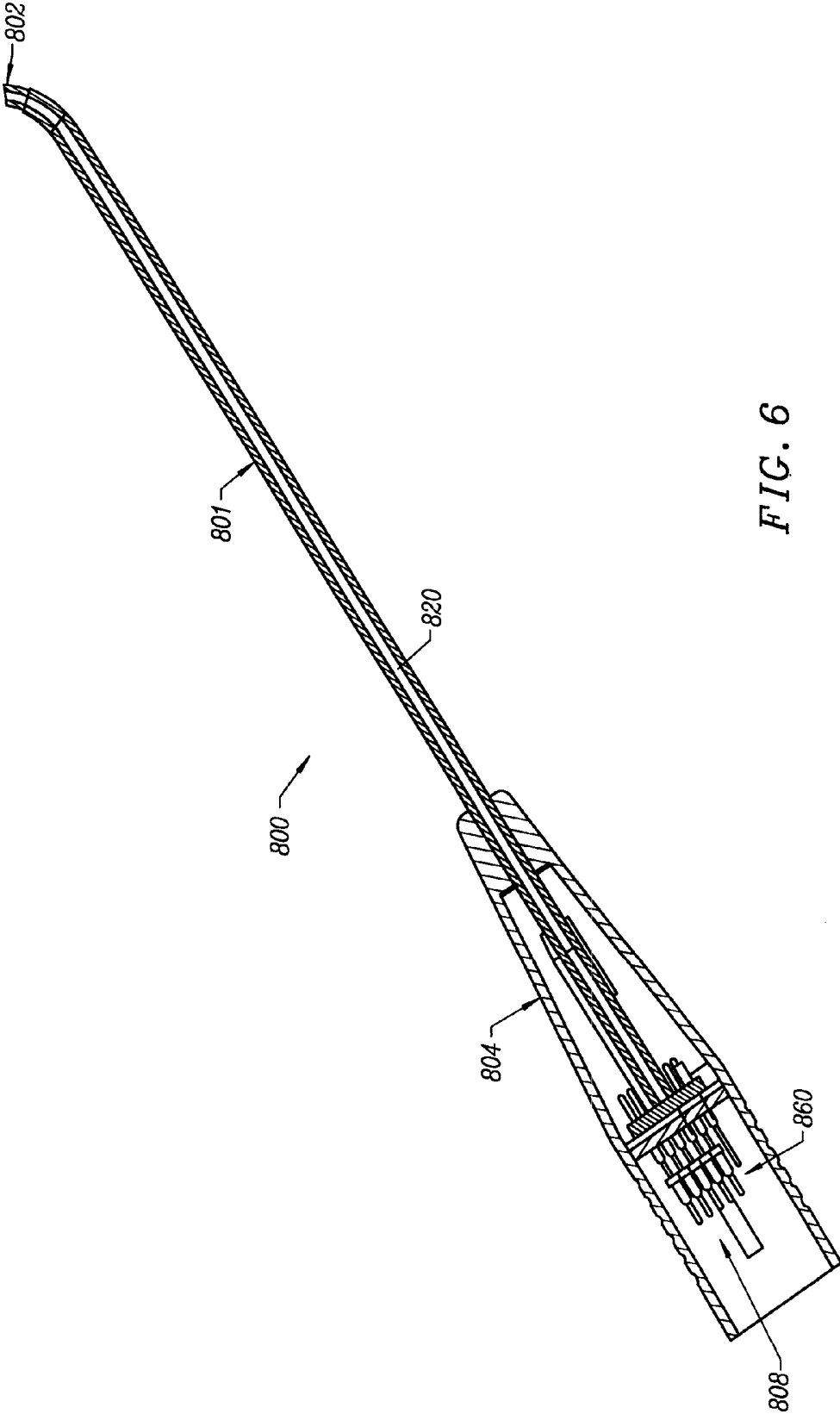

FIG. 6

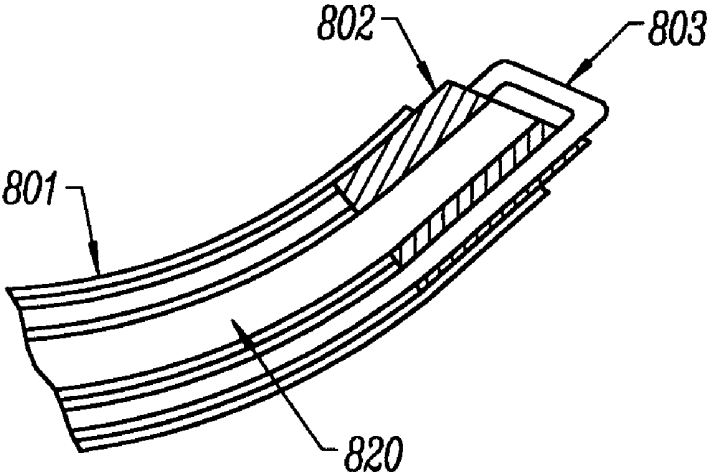

FIG. 7

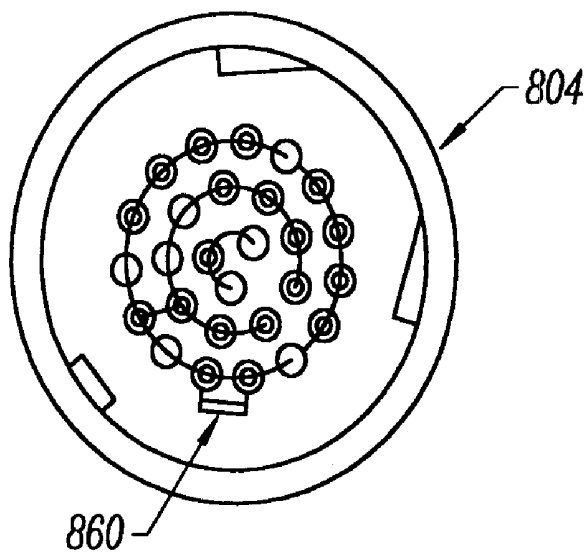

FIG. 8

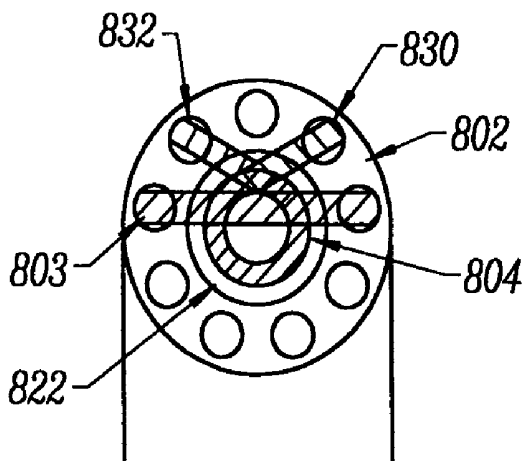

FIG. 9

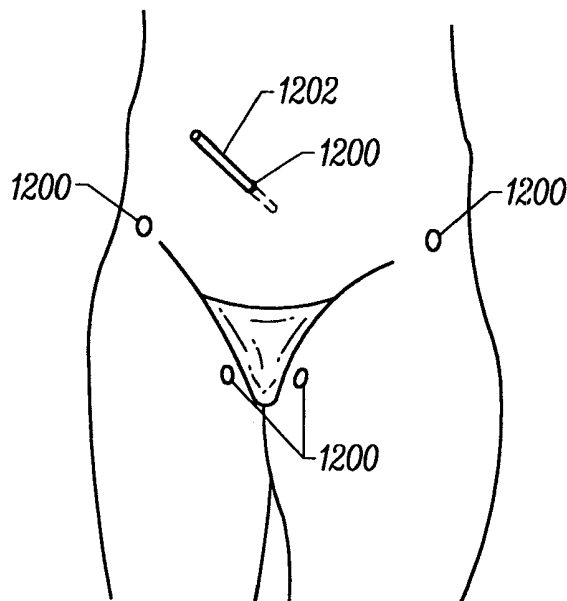

FIG. 10

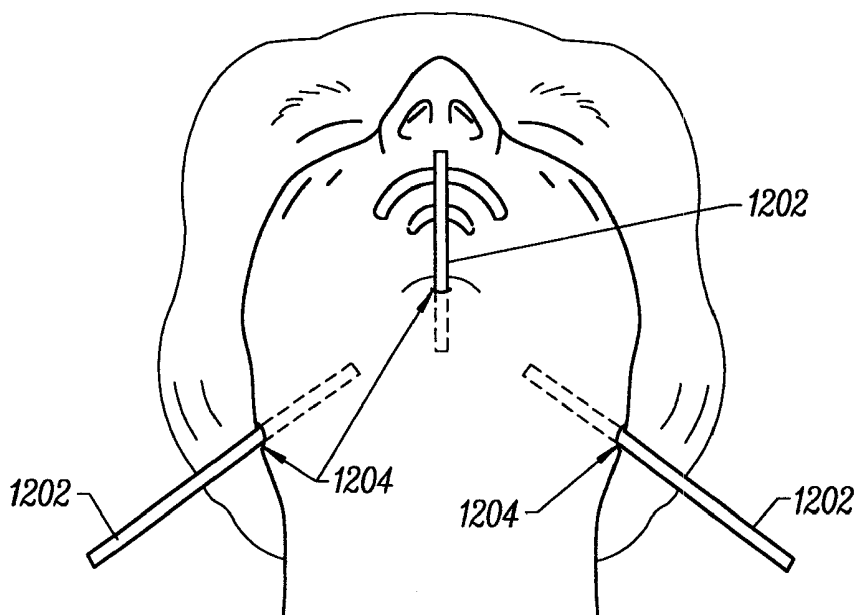

FIG. 11

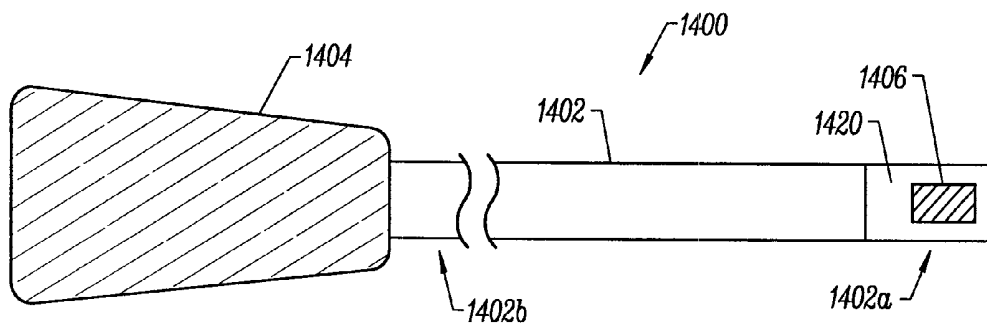

FIG. 12

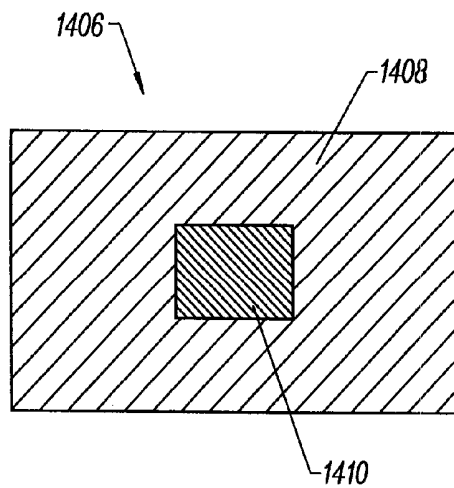

FIG. 13

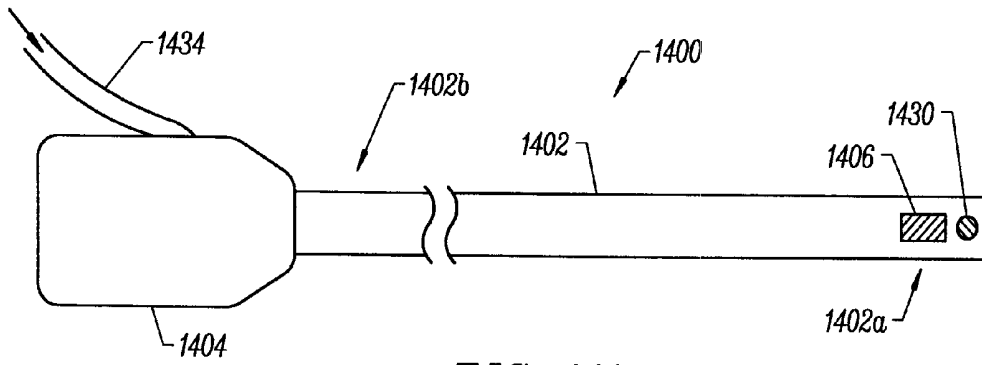

FIG. 14A

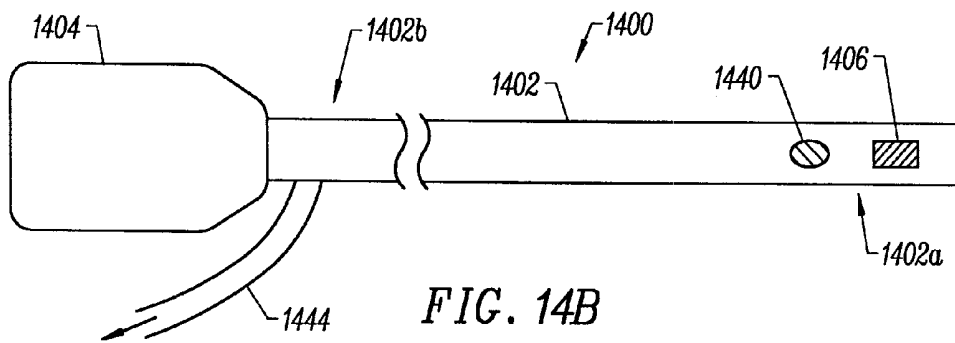

FIG. 14B

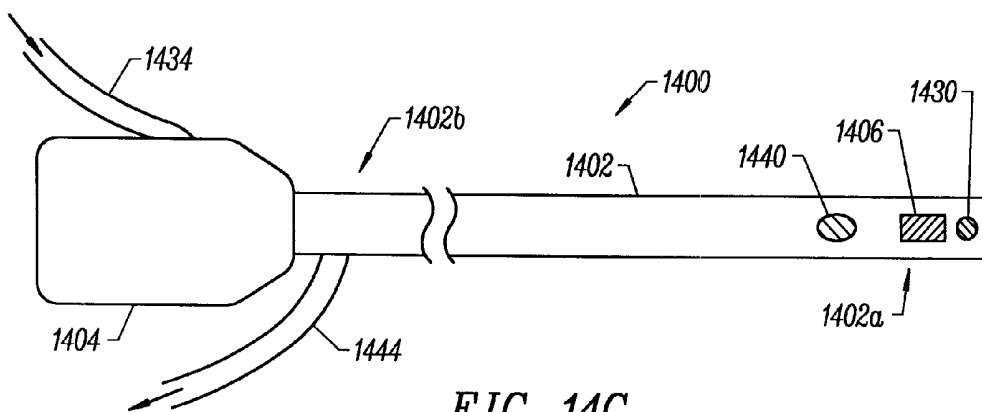
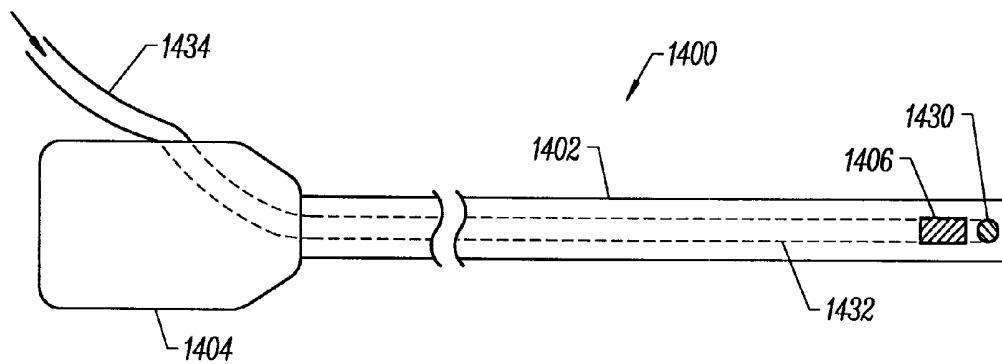
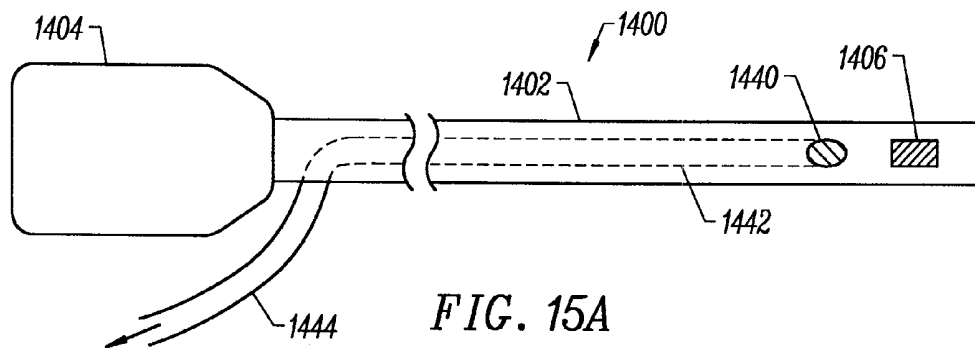
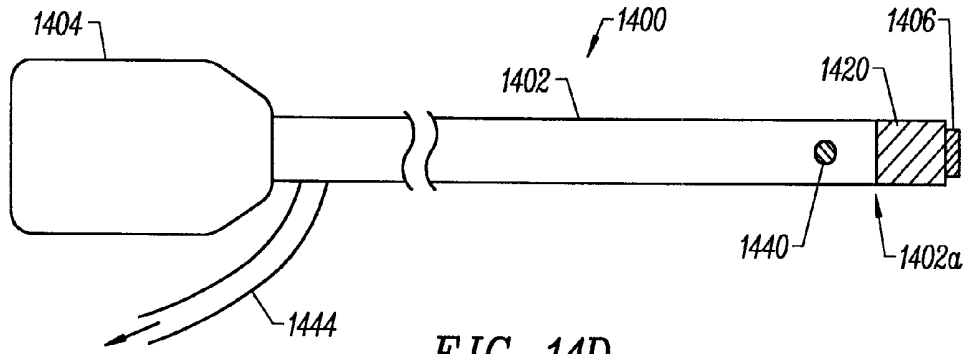

FIG. 14C



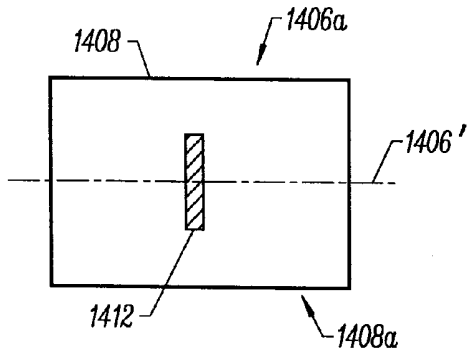

FIG. 16A

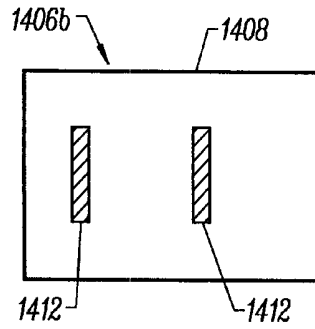

FIG. 16B

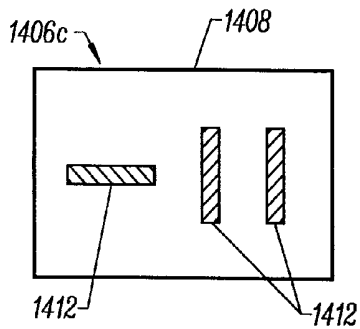

FIG. 16C

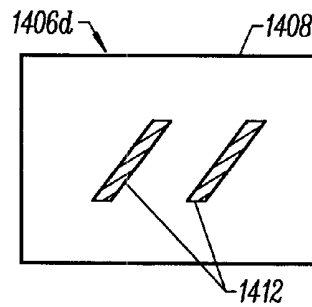

FIG. 16D

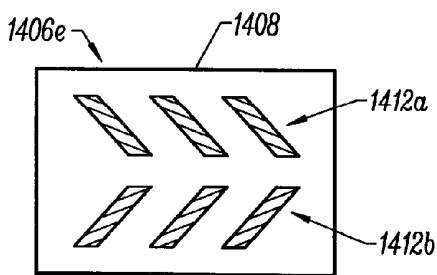

FIG. 16E

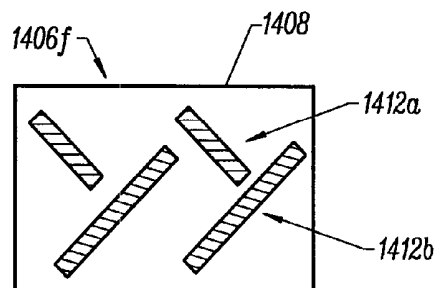

FIG. 16F

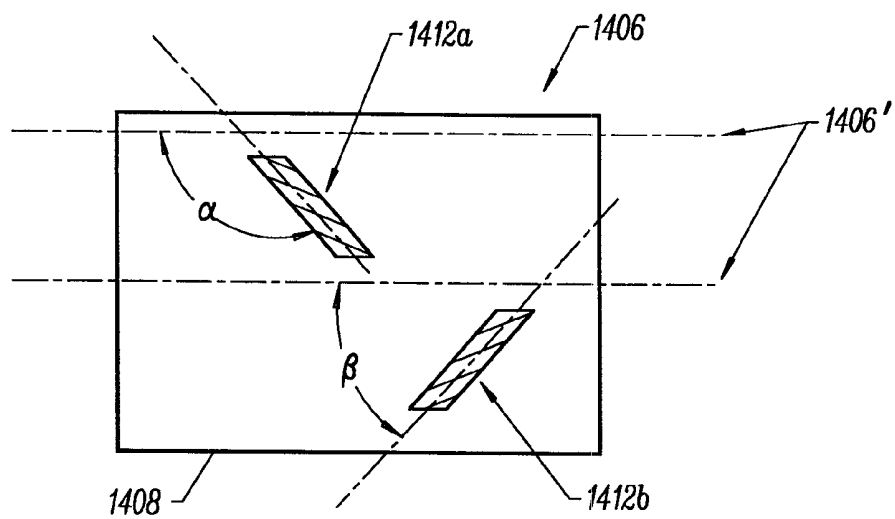

FIG. 17

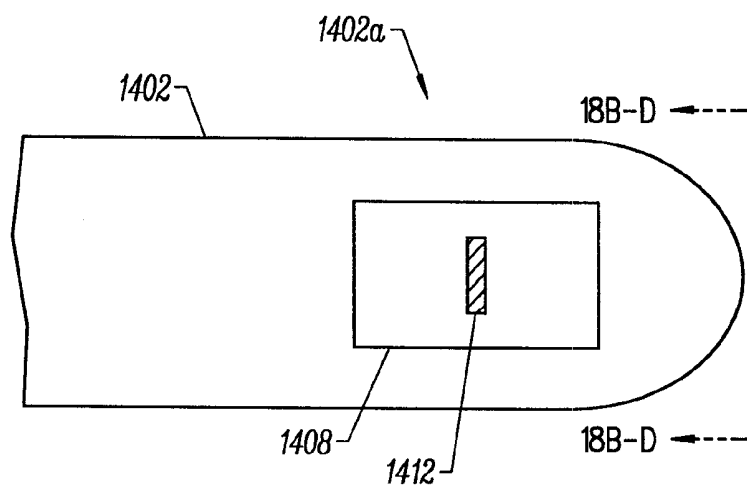
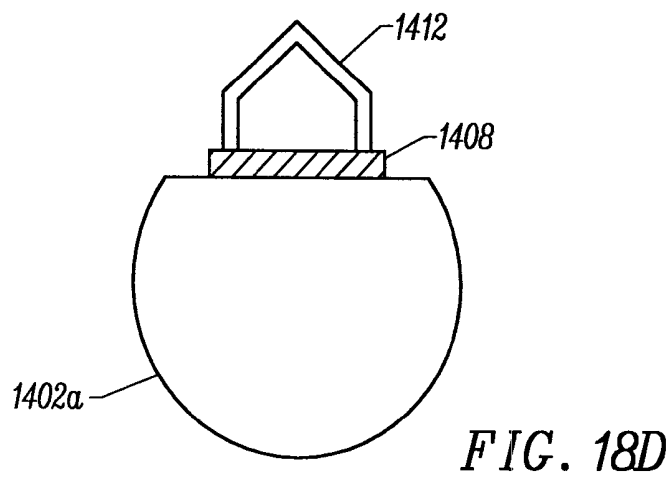
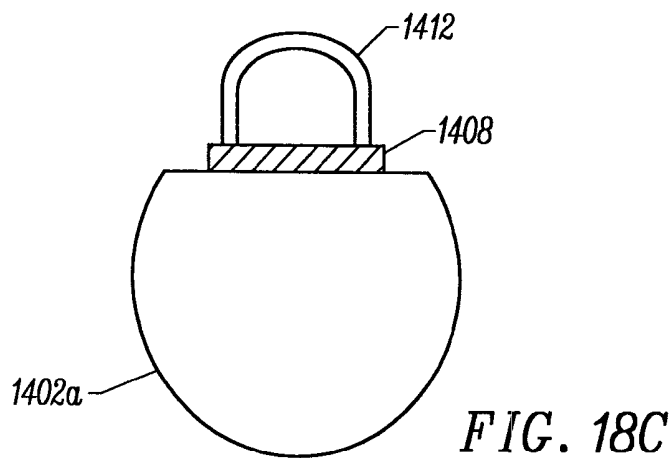
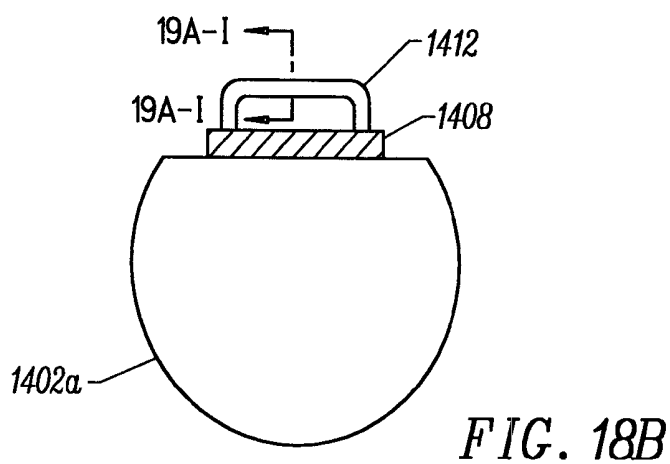

FIG. 18A



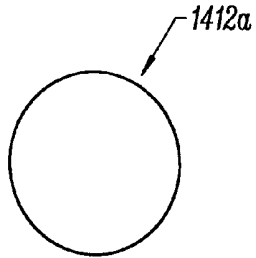

FIG. 19A

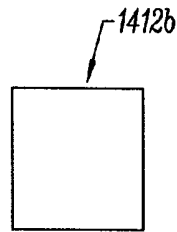

FIG. 19B

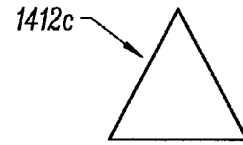

FIG. 19C

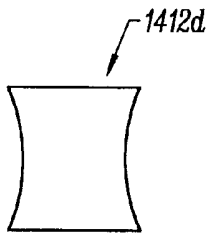

FIG. 19D

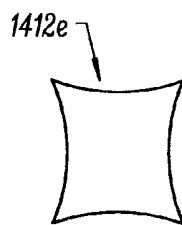

FIG. 19E

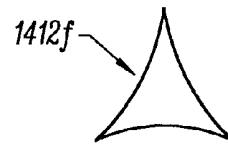

FIG. 19F

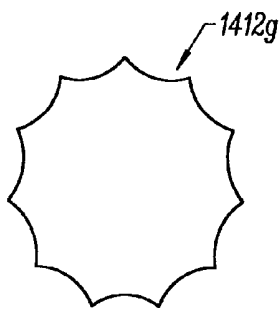

FIG. 19G

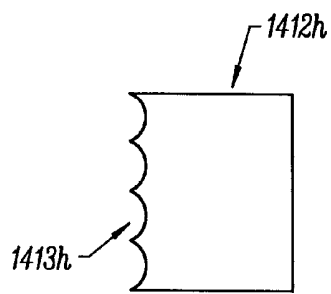

FIG. 19H

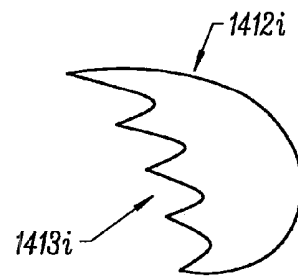

FIG. 19I

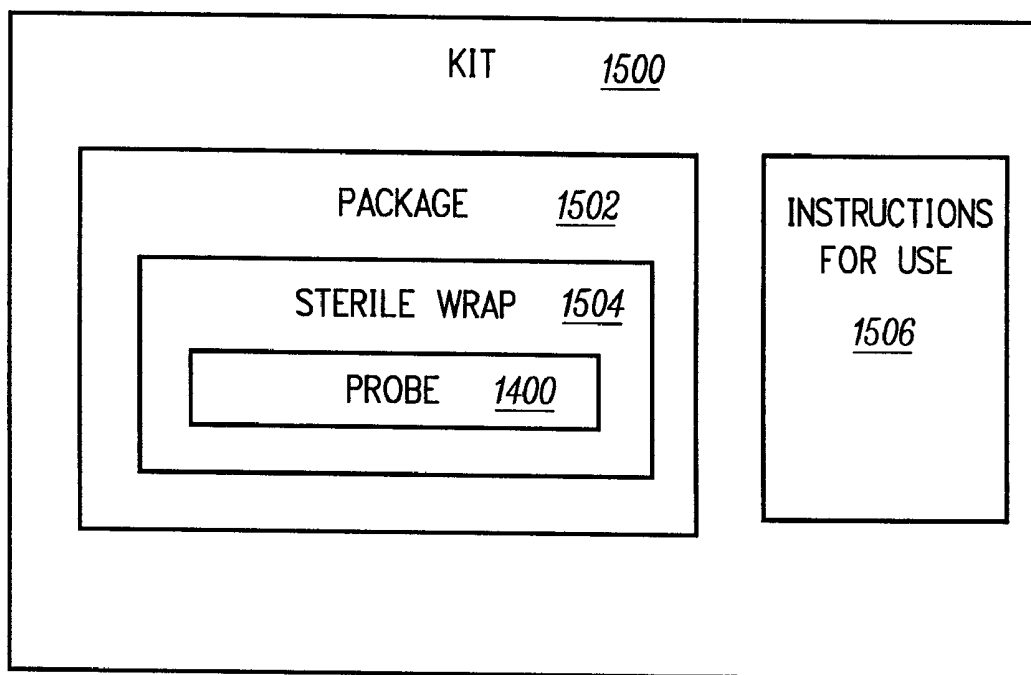

FIG. 20

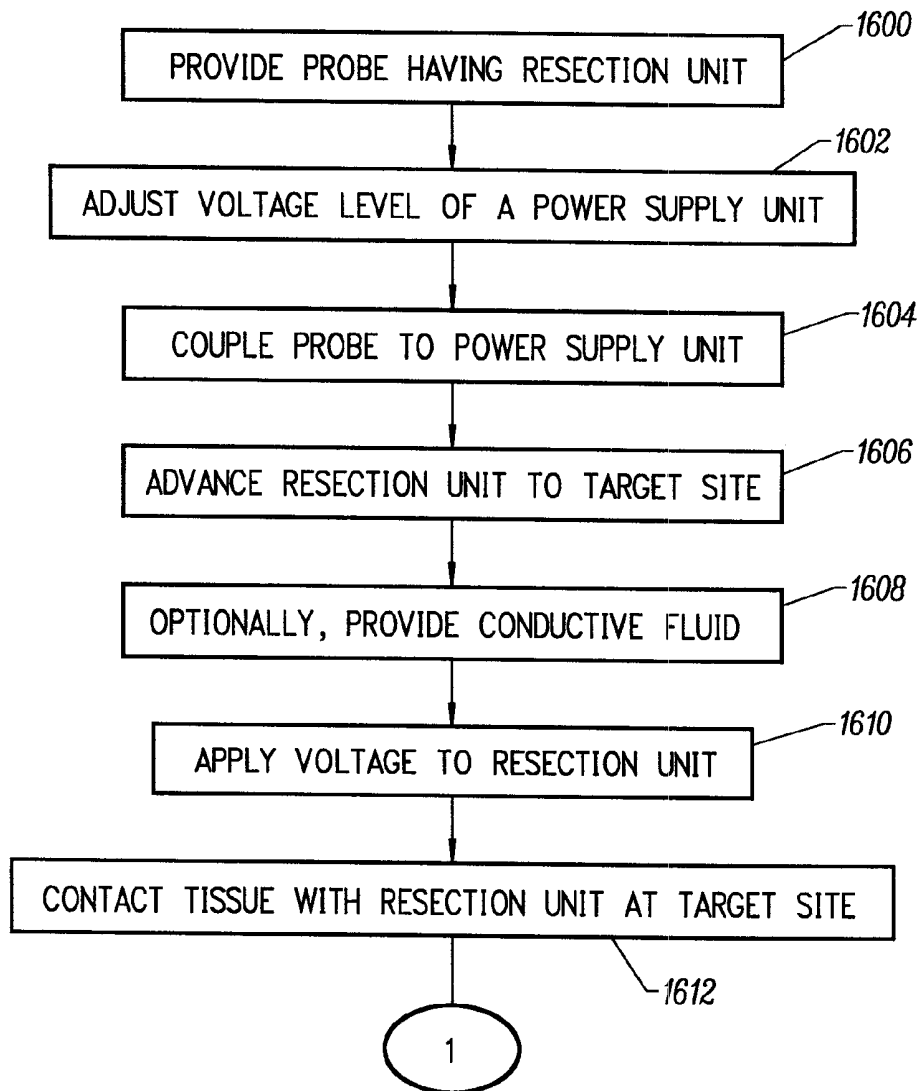

FIG. 21A

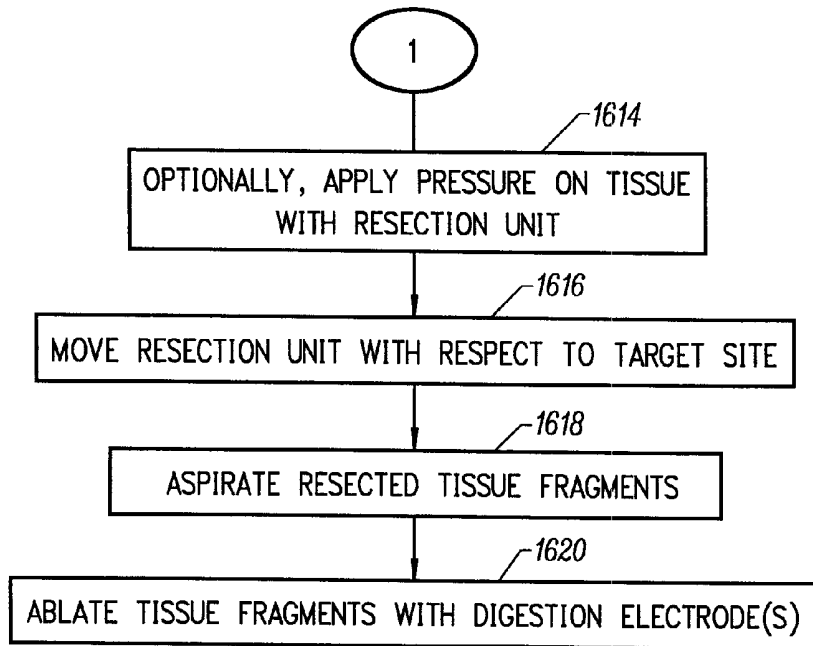

FIG. 21B

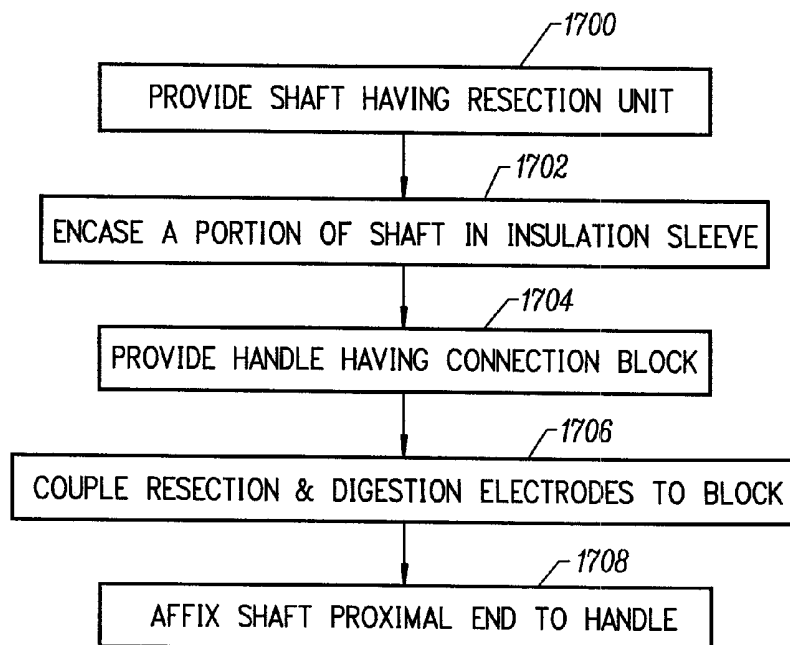

FIG. 22

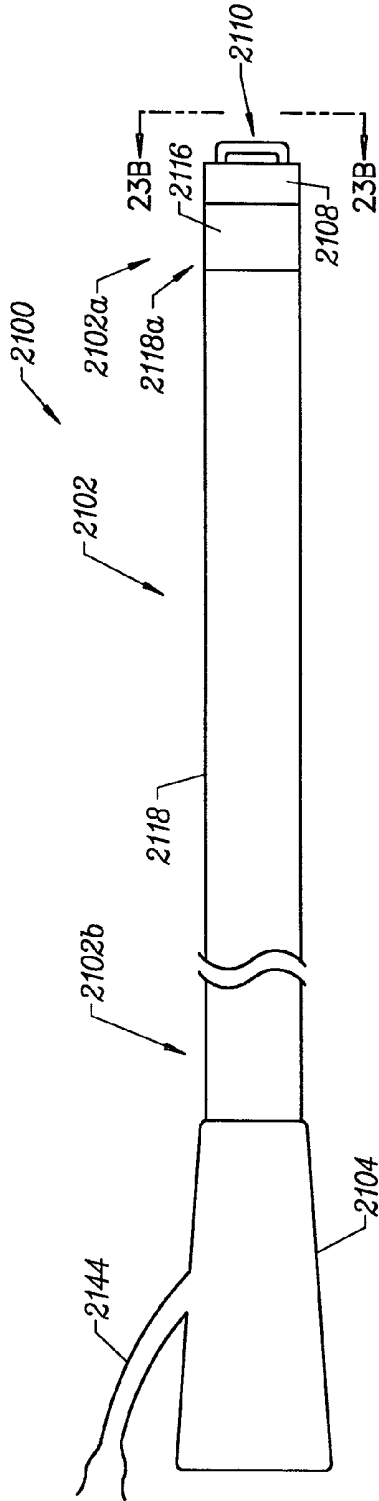

FIG. 23A

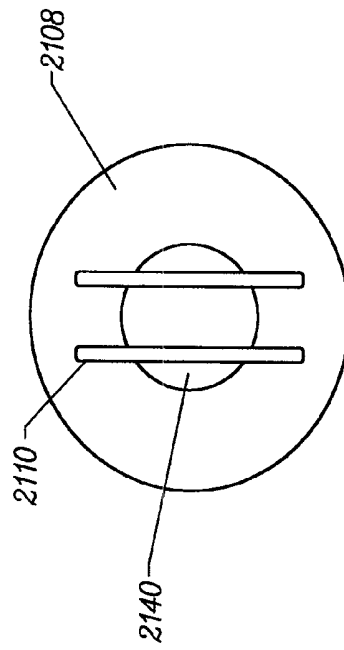

FIG. 23B

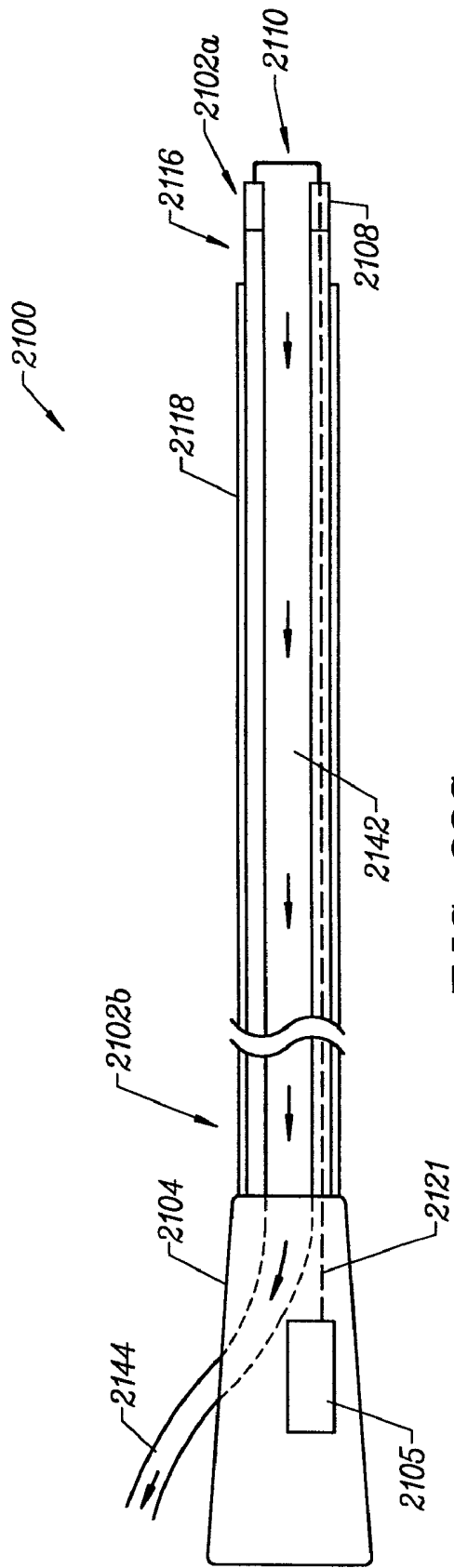

FIG. 23C

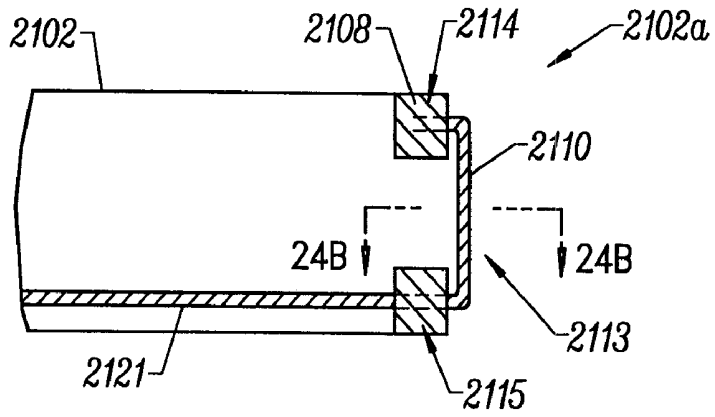

FIG. 24A

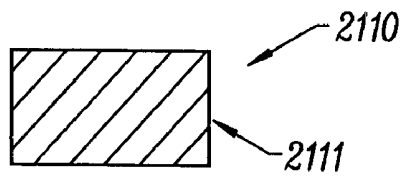

FIG. 24B

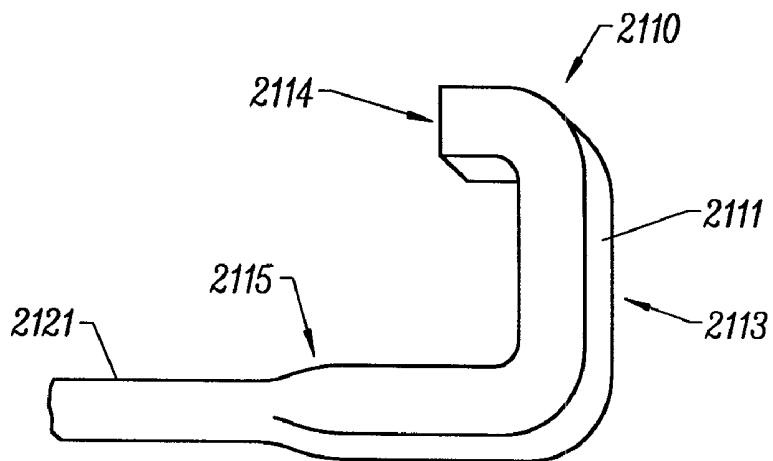

FIG. 24C

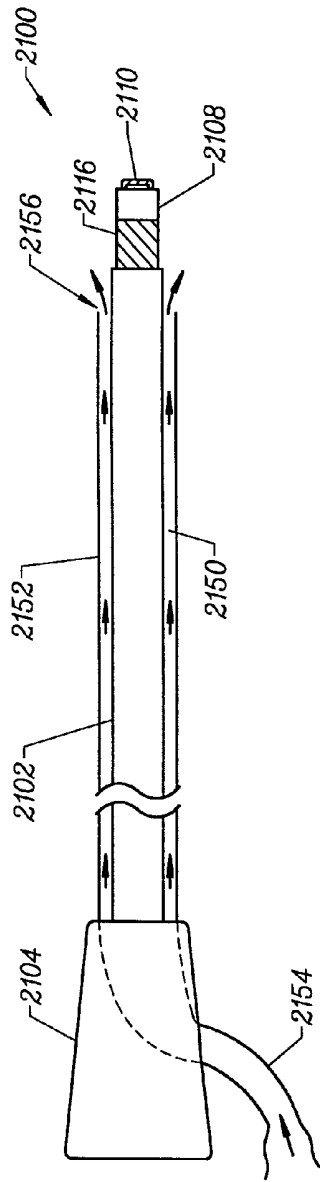

FIG. 25A

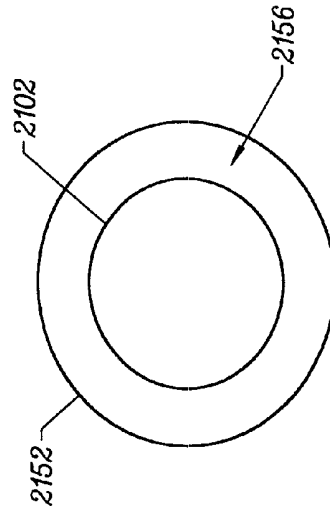

FIG. 25B

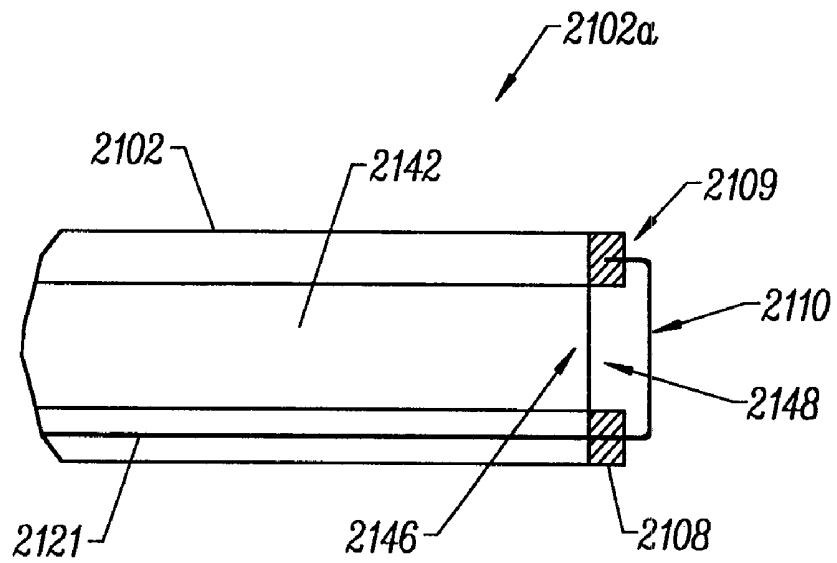

FIG. 26A

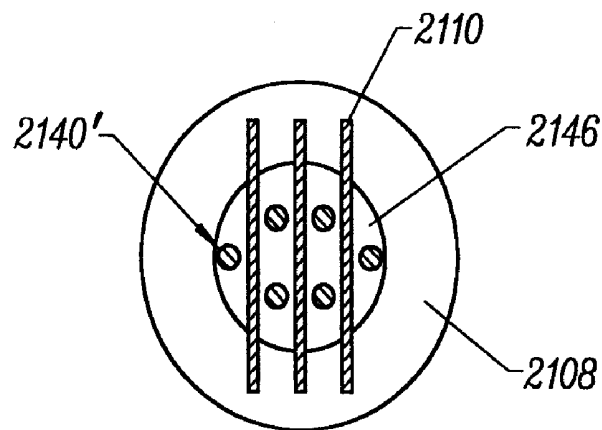

FIG. 26B

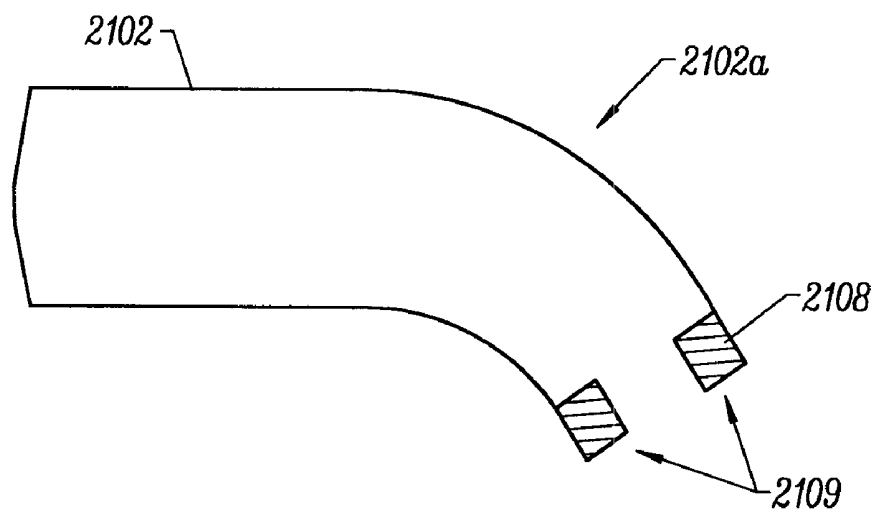

FIG. 27A

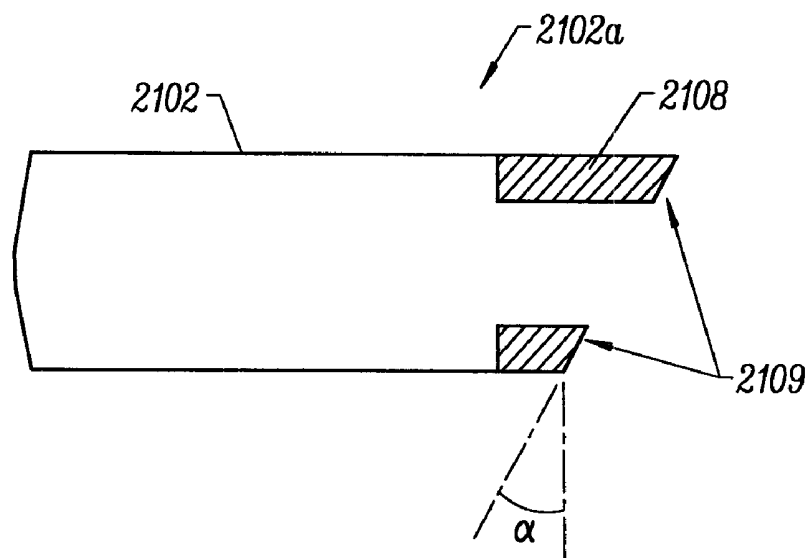

FIG. 27B

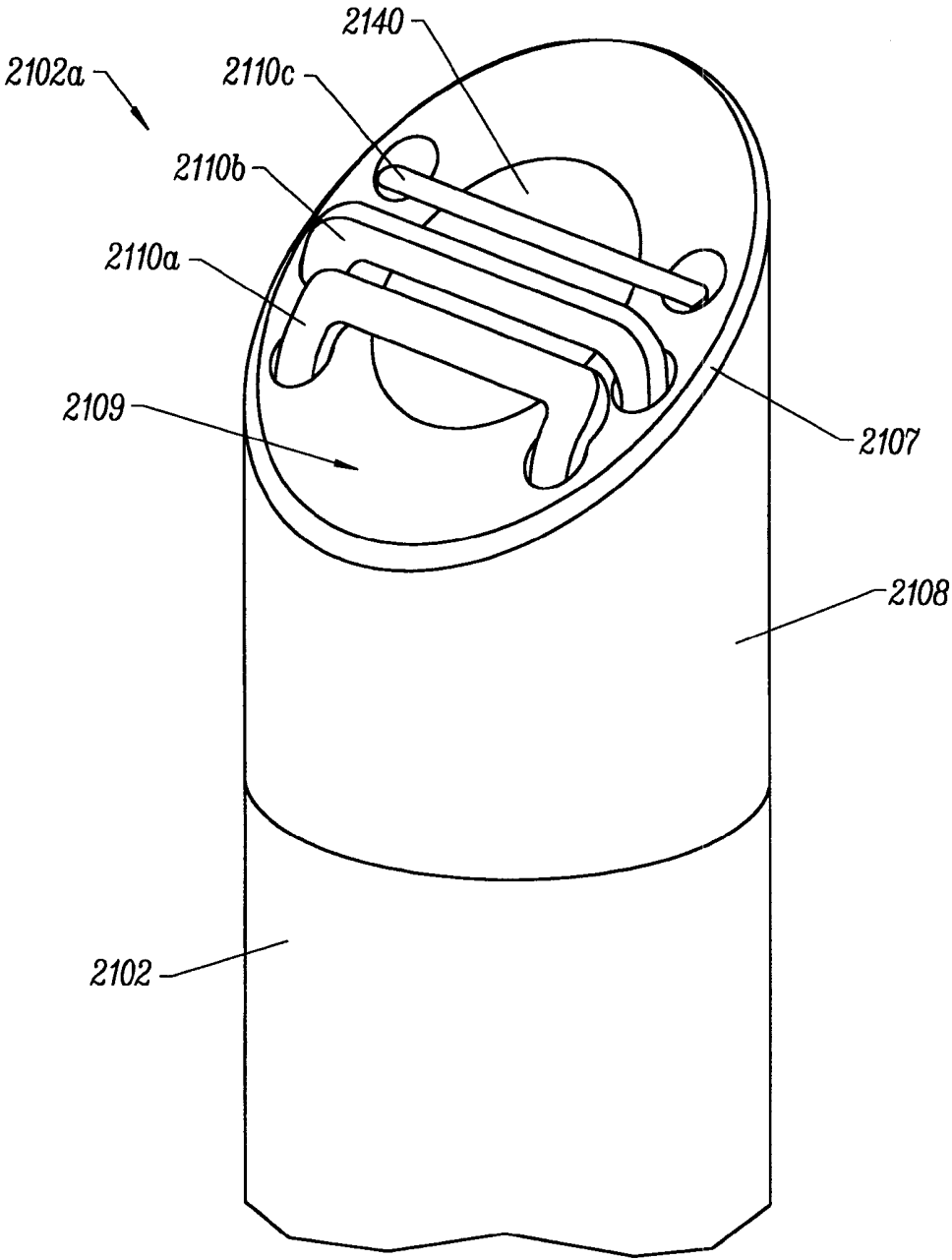

FIG. 28A

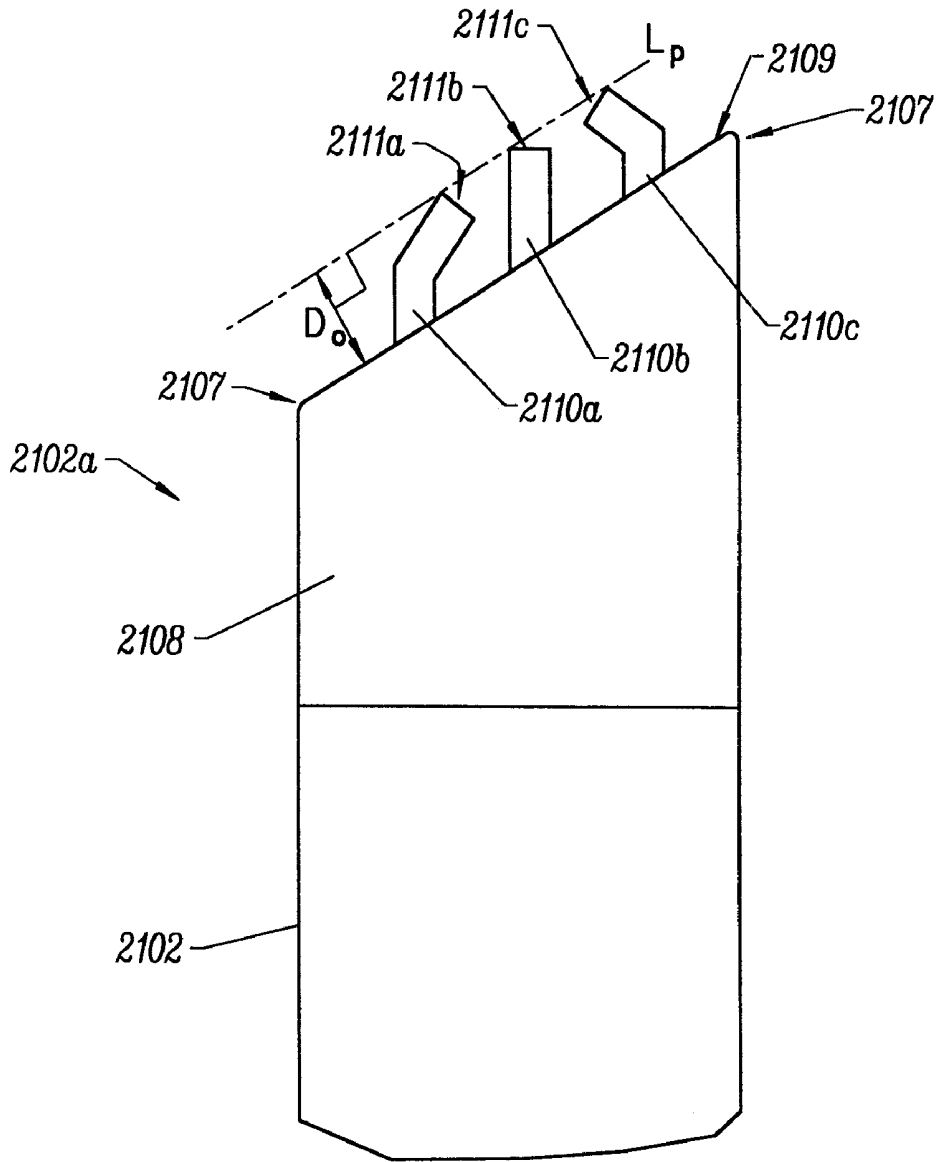

FIG. 28B

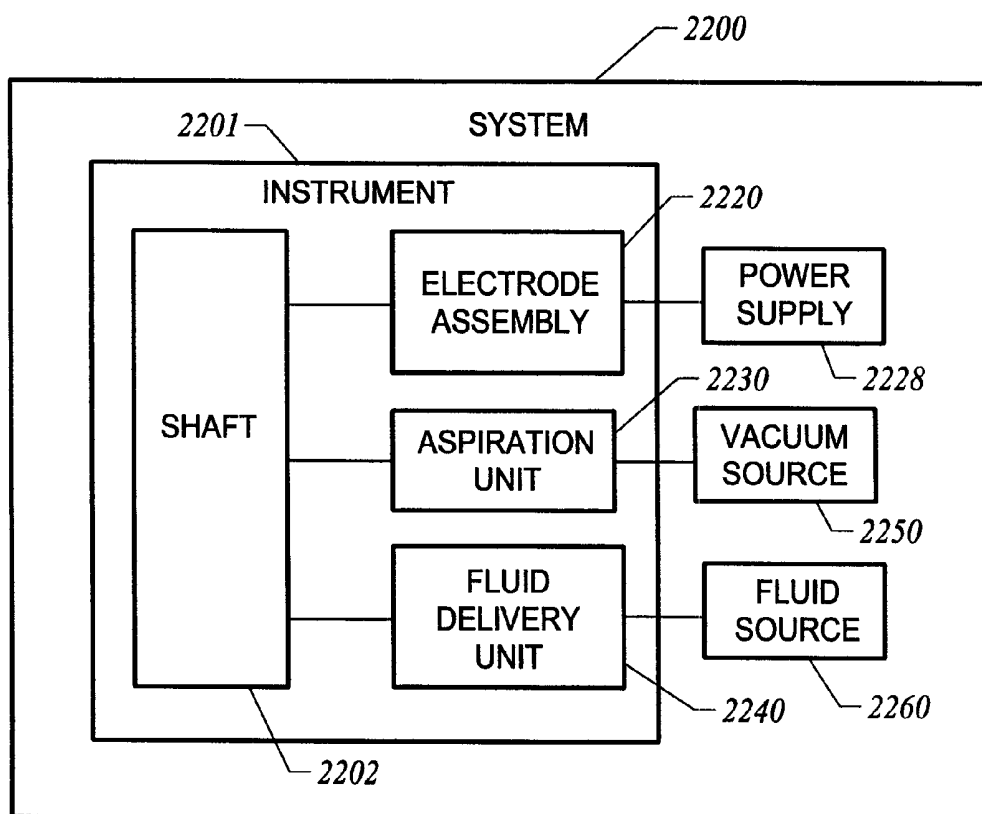

FIG. 29

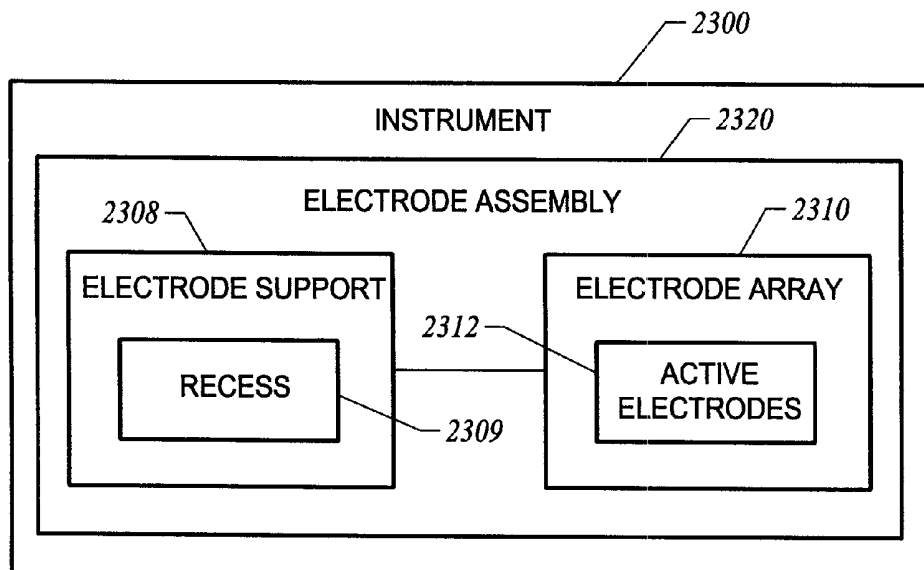

FIG. 30

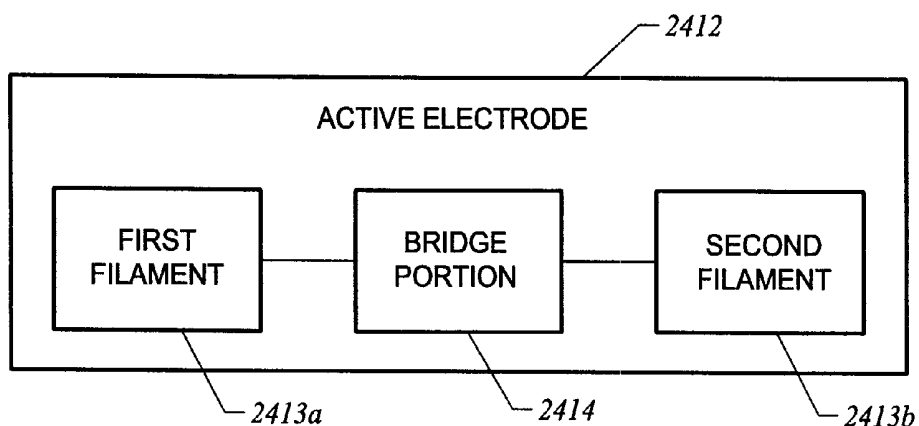

FIG. 31

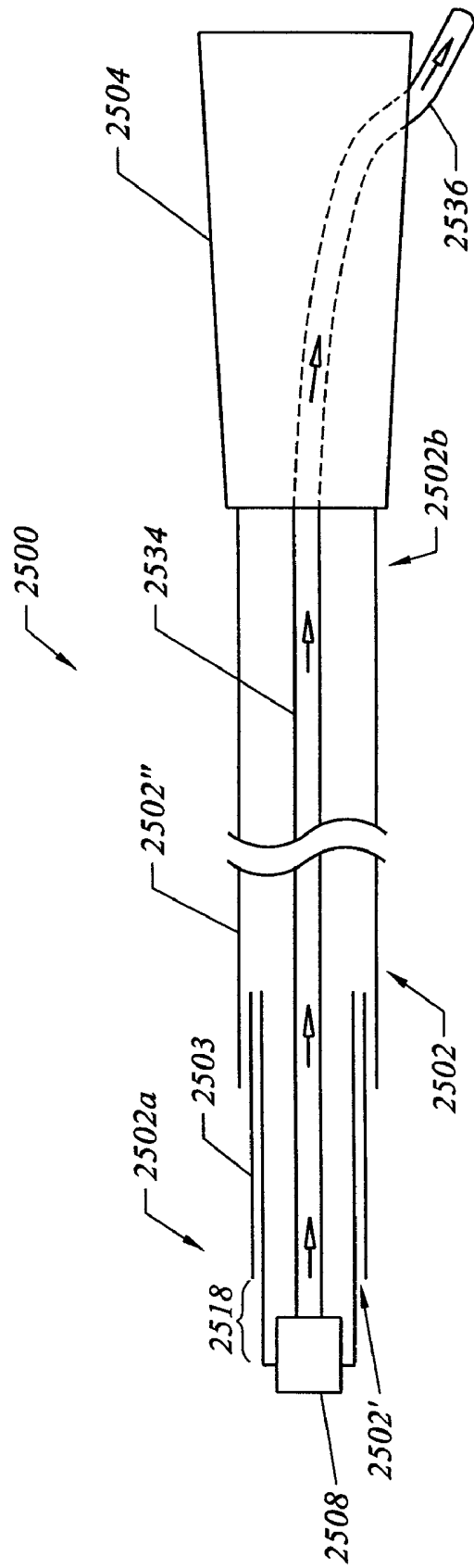

FIG. 32

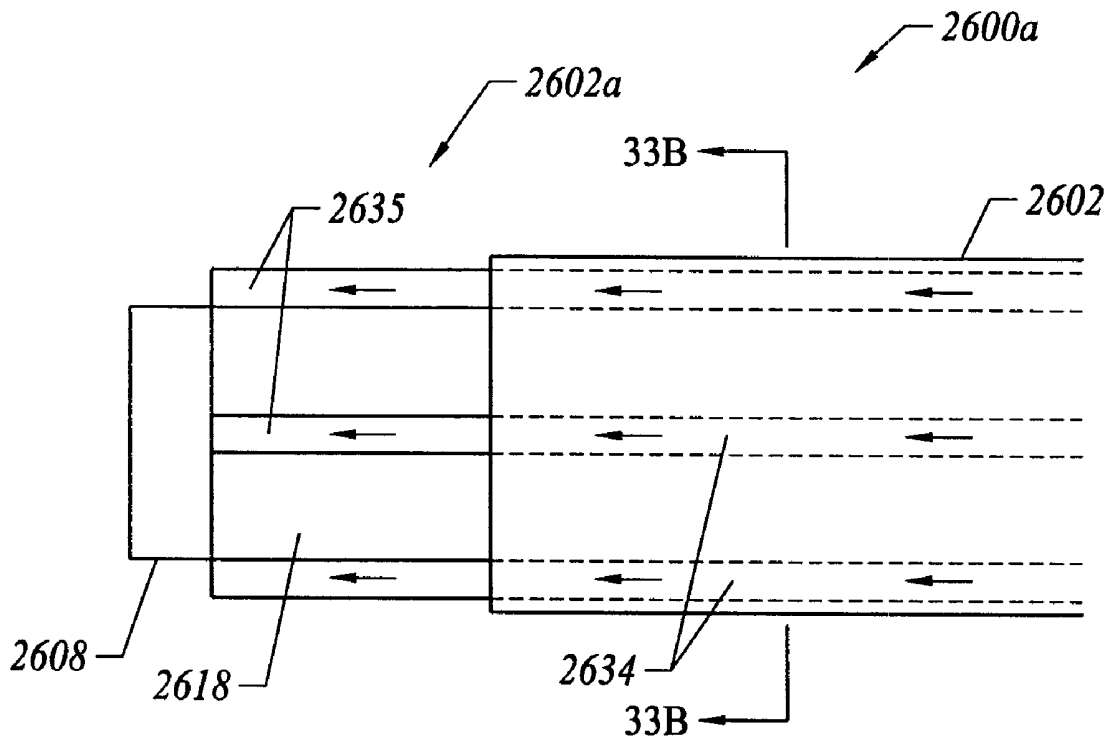

FIG. 33A

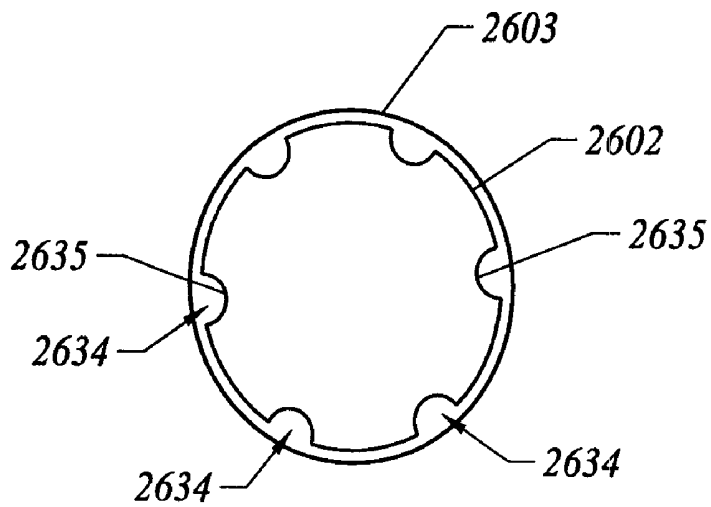

FIG. 33B

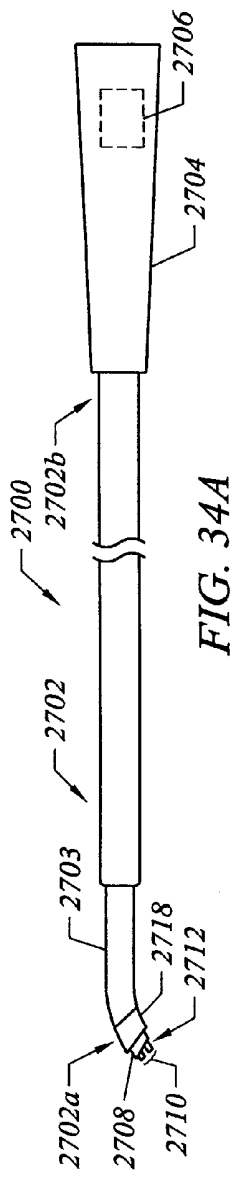

FIG. 34A

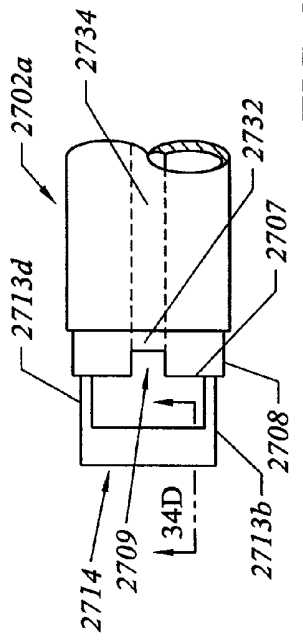

FIG. 34C

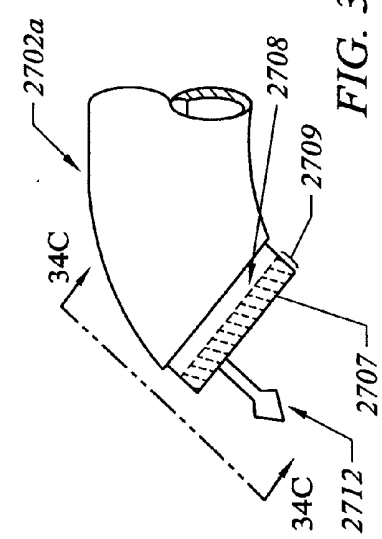

FIG. 34B

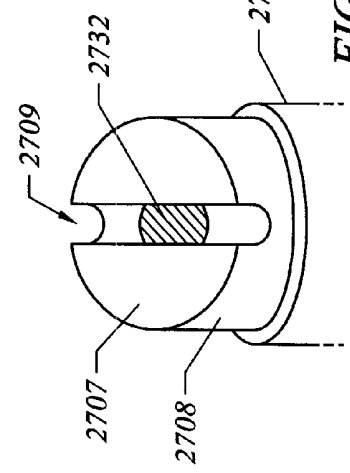

FIG. 34E

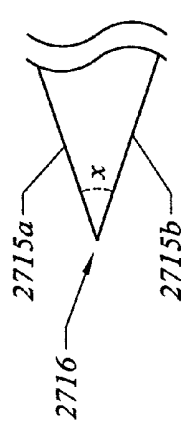

FIG. 34D

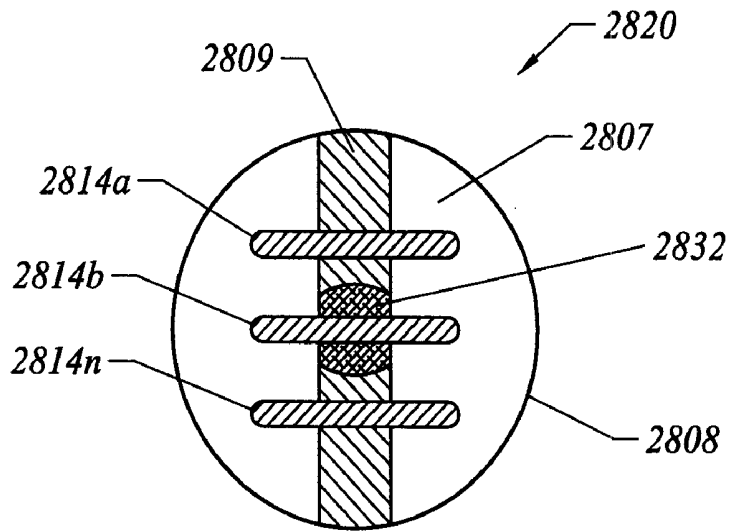

FIG. 35

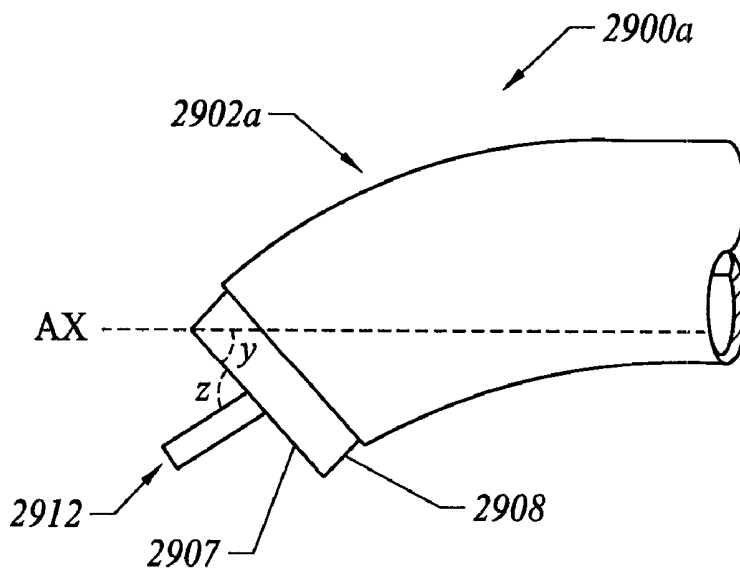

FIG. 36

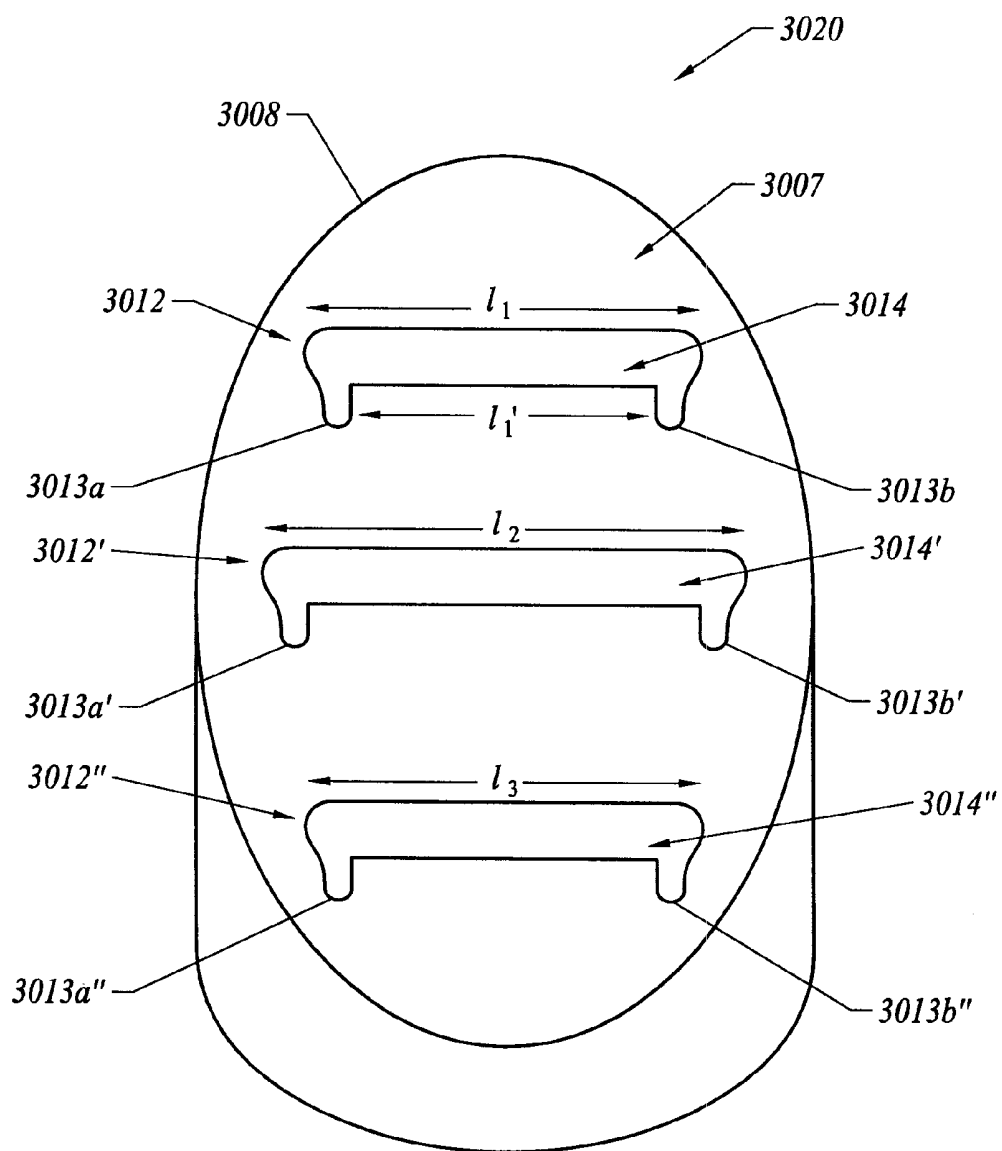

FIG. 37

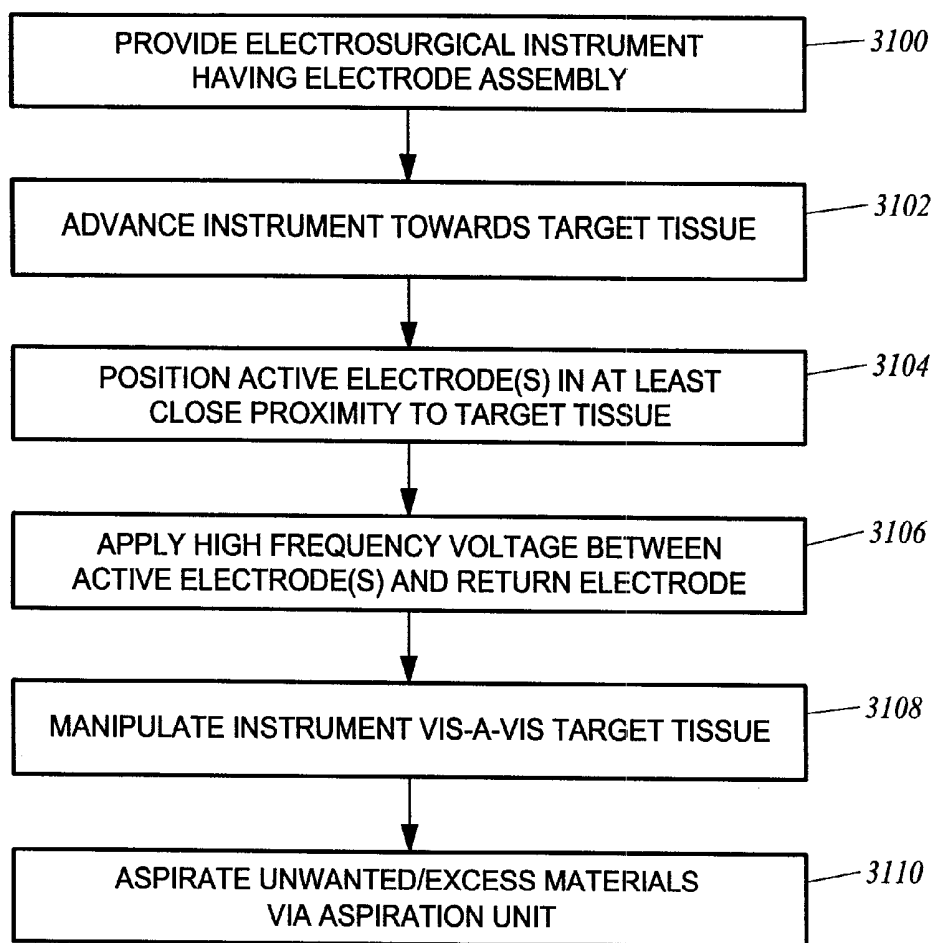

FIG. 38

ELECTROSURGICAL APPARATUS AND METHODS FOR LAPAROSCOPY

RELATED APPLICATIONS

[0001] The present application is a divisional of U.S. application Ser. No. 10/365,759, filed Feb. 14, 2003, which is a non-provisional of U.S. Provisional Application 60/356,451 filed Feb. 11, 2002, the complete disclosures of which are incorporated by reference. U.S. application Ser. No. 10/365,759 is also a continuation-in-part of U.S. patent application Ser. No. 09/766,168 filed Jan. 19, 2001, now U.S. Pat. No. 6,589,237 which is a continuation-in-part of U.S. Provisional Patent Application No. 60/233,345 filed Sep. 18, 2000, which claims priority from U.S. Provisional Patent Application No. 60/210,567 filed Jun. 9, 2000. U.S. patent application Ser. No. 09/766,168, now U.S. Pat. No. 6,589,237 filed Jan. 19, 2001, is a continuation-in-part of U.S. patent application Ser. No. 09/197,013, filed Nov. 20, 1998, now U.S. Pat. No. 6,296,638 which is a continuation-in-part of U.S. patent application Ser. No. 09/010,382, filed Jan. 21, 1998, now U.S. Pat. No. 6,190,381, which is a continuation-in-part of U.S. patent application Ser. No. 08/990,374, filed on Dec. 15, 1997, now U.S. Pat. No. 6,109,268, which is a continuation-in-part of U.S. patent application Ser. No. 08/485,219, filed on Jun. 7, 1995, now U.S. Pat. No. 5,697,281, which is a continuation-in-part of U.S. patent application Ser. No. 08/446,767 filed Jun. 2, 1995, now U.S. Pat. No. 5,697,909, which is U.S. national stage entry of International Application No. PCT/US94/05168 filed May 10, 1994, which is a continuation-in-part of U.S. patent application Ser. No. 08/059,681, filed on May 10, 1993, now abandoned, the complete disclosures of which are incorporated herein by reference for all purposes.

[0002] The present invention is related to commonly assigned U.S. Provisional Patent Application No. 60/062,997 filed on Oct. 23, 1997, U.S. patent application Ser. No. 08/977,845 filed Nov. 25, 1997, now U.S. Pat. No. 6,210,402, which is a continuation-in-part of U.S. patent application Ser. No. 08/562,332 filed Nov. 22, 1995, now U.S. Pat. No. 6,024,733, the complete disclosures of which are incorporated herein by reference for all purposes. The present invention is also related to U.S. patent application Ser. Nos. 09/109,219, 09/058,571, 08/874,173 and 09/002,315, filed on Jun. 30, 1998, Apr. 10, 1998, Jun. 13, 1997, and Jan. 2, 1998, respectively and U.S. patent application Ser. No. 09/054,323 filed on Apr. 2, 1998, U.S. patent application Ser. No. 09/010,382 filed Jan. 21, 1998, and U.S. patent application Ser. No. 09/032,375 filed Feb. 27, 1998, U.S. patent application Ser. No. 08/942,580, filed on Oct. 2, 1997, U.S. patent application Ser. No. 08/753,227 filed on Nov. 22, 1996, and U.S. patent application Ser. No. 08/687,792 filed on Jul. 18, 1996, the complete disclosures of which are incorporated herein by reference for all purposes. The present invention is also related to commonly assigned U.S. patent application Ser. No. 08/562,331 filed Nov. 22, 1995, now U.S. Pat. No. 5,683,366, the complete disclosure of which is incorporated herein by reference for all purposes.

BACKGROUND OF THE INVENTION

[0003] The present invention relates generally to the field of electrosurgery, and more particularly to surgical devices and methods which employ high frequency electrical energy to ablate, resect, coagulate, or otherwise modify a target tissue. The present invention also relates to apparatus and methods

for the controlled removal of tissue at a target site by electrosurgical ablation (e.g., Coblation®), and for efficiently aspirating resected tissue from the target site, wherein the depth to which tissue is removed can be precisely controlled with minimal or no collateral damage, and all ablation by-products are removed via an aspiration unit.

[0004] Conventional electrosurgical methods generally reduce patient bleeding associated with tissue cutting operations and improve the surgeon's visibility. These electrosurgical devices and procedures, however, suffer from a number of disadvantages. For example, monopolar electrosurgery methods generally direct electric current along a defined path from the exposed or active electrode through the patient's body to the return electrode, which is externally attached to a suitable location on the patient's skin. In addition, since the defined path through the patient's body has a relatively high electrical impedance, large voltage differences must typically be applied between the active and return electrodes to generate a current suitable for cutting or coagulation of the target tissue. This current, however, may inadvertently flow along localized pathways in the body having less impedance than the defined electrical path. This situation will substantially increase the current flowing through these paths, possibly causing damage to or destroying tissue along and surrounding this pathway.

[0005] Bipolar electrosurgical devices have an inherent advantage over monopolar devices because the return current path does not flow through the patient beyond the immediate site of application of the bipolar electrodes. In bipolar devices, both the active and return electrode are typically exposed so that they may both contact tissue, thereby providing a return current path from the active to the return electrode through the tissue. One drawback with this configuration, however, is that the return electrode may cause tissue desiccation or destruction at its contact point with the patient's tissue.

[0006] Another limitation of conventional bipolar and monopolar electrosurgery devices is that they are not suitable for the precise removal (ablation) of tissue. For example, conventional electrosurgical cutting devices typically operate by creating a voltage difference between the active electrode and the target tissue, causing an electrical arc to form across the physical gap between the electrode and tissue. At the point of contact of the electric arcs with tissue, rapid tissue heating occurs due to high current density between the electrode and tissue. This high current density causes cellular fluids to rapidly vaporize into steam, thereby producing a "cutting effect" along the pathway of localized tissue heating. The tissue is parted along the pathway of vaporized cellular fluid, inducing undesirable collateral tissue damage in regions surrounding the target tissue site.

[0007] In addition, conventional electrosurgical methods are generally ineffective for ablating certain types of tissue, and in certain types of environments within the body. For example, loose or elastic connective tissue, such as the synovial tissue in joints, is extremely difficult (if not impossible) to remove with conventional electrosurgical instruments because the flexible tissue tends to move away from the instrument when it is brought against this tissue. Since conventional techniques rely mainly on conducting current through the tissue, they are not effective when the instrument cannot be brought adjacent to or in contact with the elastic tissue for a long enough period of time to energize the electrode and conduct current through the tissue.

[0008] The use of electro-surgical procedures (both monopolar and bipolar) in electrically conductive environments can be further problematic. For example, many arthroscopic procedures require flushing of the region to be treated with isotonic saline, both to maintain an isotonic environment and to keep the field of view clear. However, the presence of saline, which is a highly conductive electrolyte, can cause shorting of the active electrode(s) in conventional monopolar and bipolar electro-surgery. Such shorting causes unnecessary heating in the treatment environment and can further cause non-specific tissue destruction.

[0009] Conventional electro-surgical cutting or resecting devices also tend to leave the operating field cluttered with tissue fragments that have been removed or resected from the target tissue. These tissue fragments make visualization of the surgical site extremely difficult. Removing these tissue fragments can also be problematic. Similar to synovial tissue, it is difficult to maintain contact with tissue fragments long enough to ablate the tissue fragments in situ with conventional devices. To solve this problem, the surgical site is periodically or continuously aspirated during the procedure. However, the tissue fragments often clog the aspiration lumen of the suction instrument, forcing the surgeon to remove the instrument to clear the aspiration lumen or to introduce another suction instrument, which increases the length and complexity of the procedure.

[0010] Endometriosis is a common condition due to the presence of ectopic endometrial tissue, usually within the abdominal cavity, which can lead to infertility in women. Endometrial lesions or implants respond to ovarian hormonal changes, similar to the uterine endometrium. Symptoms of endometriosis include localized bleeding, pain, inflammation, scarring, and adhesion formation.

[0011] There is a need for improved treatment of endometriosis. Medical therapy for endometriosis is basically hormonal. Treatment with continuous progesterone can shrink endometriotic implants. Treatment that causes a significant decrease in estrogen levels (pseudomenopausal state) is generally more effective than a prolonged progesterone effect. Agents that suppress ovarian estrogen production include Danazol (a weak androgenic hormone), and Lupron (a gonadotropin-releasing hormone agonist). Prescription of such products is usually limited to periods of not more than six months due to their side effects (including bone demineralization and increased risk of cardiovascular disease). Often, the beneficial effects of such products are short-lived following cessation of treatment. Prior to recent advances in laparoscopic instrumentation and procedures, a common treatment for endometriosis was pelvic laparotomy. Lasers have been used for removal of endometrial lesions. However, in the context of surgical ablation, lasers suffer from a number of disadvantages, as outlined hereinabove. Thus, there is a need for improved electro-surgical instruments which allow the removal of ectopic endometrial tissue from various sites during minimally invasive laparoscopic procedures, wherein the target tissue is removed in a highly controlled manner with little or no collateral damage.

[0012] The instant invention provides methods and electro-surgical apparatus for the controlled removal or coagulation of target tissue during laparoscopic procedures with no or minimal damage to delicate, easily damaged underlying tissue.

SUMMARY OF THE INVENTION

[0013] The present invention provides systems, apparatus, and methods for selectively applying electrical energy to structures or tissue of a patient's body. In particular, methods

and apparatus are provided for resecting, cutting, ablating, aspirating, or otherwise removing tissue from a target site in situ, during laparoscopic procedures. The invention also provides systems and apparatus for spot coagulation and ablation of target tissue, such as ectopic endometrial tissue present on delicate underlying tissue or organs, such as the ovaries, ureter, urinary bladder, and bowel.

[0014] In one aspect, the present invention provides an electro-surgical instrument for treating tissue at a target site. The instrument comprises a shaft having a proximal portion and a distal end portion. One or more active loop electrodes are disposed at the distal end of the shaft. The loop electrodes preferably have one or more edges that promote high electric fields. A connector is disposed near the proximal end of the shaft for electrically coupling the active loop electrodes to a high frequency source.

[0015] The active loop electrodes typically have an exposed semicircular shape that facilitates the removing or ablating of tissue at the target site. During the procedure, bodily fluid, non-ablated tissue fragments and/or air bubbles are aspirated from the target site to improve visualization.

[0016] At least one return electrode is preferably spaced from the active electrode(s) a sufficient distance to prevent arcing therebetween at the voltages suitable for tissue removal and or heating, and to prevent contact of the return electrode(s) with the tissue. The current flow path between the active and return electrodes may be generated by immersing the target site within electrically conductive fluid (as is typical in arthroscopic procedures), or by directing an electrically conductive fluid along a fluid path past the return electrode and to the target site (e.g., in open procedures). Alternatively, the electrodes may be positioned within a viscous electrically conductive fluid, such as a gel, at the target site, and submersing the active and return electrode(s) within the conductive gel. The electrically conductive fluid will be selected to have sufficient electrical conductivity to allow current to pass therethrough from the active to the return electrode(s), and such that the fluid ionizes into a plasma when subject to sufficient electrical energy, as discussed below. In the exemplary embodiment, the conductive fluid is isotonic saline, although other fluids may be selected, as described in co-pending Provisional Patent Application No. 60/098,122, filed Aug. 27, 1998 (Attorney Docket No. CB-7P), the complete disclosure of which is incorporated herein by reference.

[0017] In a specific embodiment, tissue ablation results from molecular dissociation or disintegration processes. Conventional electro-surgery ablates or cuts through tissue by rapidly heating the tissue until cellular fluids explode, producing a cutting effect along the pathway of localized heating. The present invention volumetrically removes tissue, e.g., cartilage tissue, in a cool ablation process known as Coblation®, wherein thermal damage to surrounding tissue is minimized. During this process, a high frequency voltage applied to the active electrode(s) is sufficient to vaporize an electrically conductive fluid (e.g., gel or saline) between the electrode(s) and the tissue. Within the vaporized fluid, an ionized plasma is formed and charged particles (e.g., electrons) cause the molecular breakdown or disintegration of tissue components in contact with the plasma. This molecular dissociation is accompanied by the volumetric removal of the tissue. This process can be precisely controlled to effect the volumetric removal of tissue as thin as 10 to 50 microns with minimal heating of, or damage to, surrounding or underlying tissue structures. A more complete description of this Cobla-

tion® phenomenon is described in commonly assigned U.S. Pat. No. 5,683,366, the complete disclosure of which is incorporated herein by reference.

[0018] In variations of the invention which use Coblation® technology, the high frequency voltage is sufficient to convert the electrically conductive fluid between the target tissue and active electrodes into an ionized vapor layer or plasma. As a result of the applied voltage difference between active electrode(s) and the target tissue (i.e., the voltage gradient across the plasma layer), charged particles in the plasma (e.g., electrons) are accelerated towards the tissue. At sufficiently high voltage differences, these charged particles gain sufficient energy to cause dissociation of the molecular bonds within tissue structures. This molecular dissociation is accompanied by the volumetric removal (i.e., ablative sublimation) of tissue and the production of low molecular weight gases, such as oxygen, nitrogen, carbon dioxide, hydrogen and methane. The short range of the accelerated charged particles within the tissue confines the molecular dissociation process to the surface layer to minimize damage and necrosis to the underlying tissue.

[0019] During the process, the gases may be aspirated through opening 609 and/or a suction tube to a vacuum source or collection reservoir. In addition, excess electrically conductive fluid and other fluids (e.g., blood) will be aspirated from the target site to facilitate the surgeon's view. Applicant has also found that tissue fragments are also aspirated through opening into suction lumen and tube during the procedure. These tissue fragments are ablated or dissociated with electrodes with a mechanism similar to that described above. Namely, as electrically conductive fluid and tissue fragments are aspirated towards loop electrodes, these electrodes are activated so that a high frequency voltage is applied to loop electrodes and return electrode (of course, the probe may include a different, separate return electrode for this purpose). The voltage is sufficient to vaporize the fluid, and create a plasma layer between loop electrodes 540 and the tissue fragments so that portions of the tissue fragments are ablated or removed. This reduces the volume of the tissue fragments as they pass through suction lumen to minimize clogging of the lumen.

[0020] The present invention offers a number of advantages over conventional electrosurgery, microdebrider, shaver and laser techniques for removing soft tissue in arthroscopic, sinus or other surgical procedures. The ability to precisely control the volumetric removal of tissue results in a field of tissue ablation or removal that is very defined, consistent and predictable. In one embodiment, the shallow depth of tissue heating also helps to minimize or completely eliminate damage to healthy tissue structures, e.g., cartilage, bone and/or nerves that are often adjacent the target tissue. In addition, small blood vessels at the target site are simultaneously cauterized and sealed as the tissue is removed to continuously maintain hemostasis during the procedure. This increases the surgeon's field of view, and shortens the length of the procedure. Moreover, since the present invention allows for the use of electrically conductive fluid (contrary to prior art bipolar and monopolar electrosurgery techniques), isotonic saline may be used during the procedure. Saline is the preferred medium for irrigation because it has the same concentration as the body's fluids and, therefore, is not absorbed into the body as much as certain other fluids.

[0021] Systems according to the present invention generally include an electrosurgical instrument having a shaft with

proximal and distal end portions, one or more active electrode(s) at the distal end of the shaft and one or more return electrode(s). The system can further include a high frequency power supply for applying a high frequency voltage difference between the active electrode(s) and the return electrode(s). The instrument typically includes an aspiration lumen within the shaft having an opening positioned proximal of the active electrode(s) so as to draw excess or unwanted materials into the aspiration lumen under vacuum pressure.

[0022] In another aspect, the present invention provides an electrosurgical probe having a fluid delivery element for delivering electrically conductive fluid to the active electrode(s) and the target site. In one exemplary configuration, the fluid delivery element includes at least one opening that is positioned around the active electrodes. Such a configuration provides an improved flow of electrically conductive fluid and promotes more aggressive generation of a plasma at the active electrode(s).

[0023] Alternatively, in some embodiments an electrically conductive fluid, such as a gel or liquid spray, e.g., saline, may be applied to the tissue using an ancillary device. In arthroscopic procedures, the target site will typically be immersed in a conductive irrigant, e.g., saline. In these embodiments, the apparatus may lack a fluid delivery element. In both embodiments, the electrically conductive fluid will preferably generate a current flow path between the active electrode(s) and the return electrode(s). In an exemplary embodiment, a return electrode is located on the instrument and spaced a sufficient distance from the active electrode(s) to substantially avoid or minimize current shorting therebetween and to shield the tissue from the return electrode at the target site.

[0024] In another aspect, the present invention provides a method for applying electrical energy to a target site within or on a patient's body. The method comprises positioning one or more active electrodes into at least close proximity with the target site. An electrically conductive fluid is provided to the target site and a high frequency voltage is applied between the active electrodes and a return electrode to generate relatively high, localized electric field intensities at the surface of the active electrode(s). The active electrodes may be moved in relation to the targeted tissue to resect or ablate the tissue at the target site.

[0025] In another aspect, the present invention provides an electrosurgical suction apparatus adapted for coupling to a high frequency power supply and for removing tissue from a target site to be treated. The apparatus includes an aspiration channel terminating in a distal opening or aspiration port, and a plurality of active electrodes in the vicinity of the distal opening. The plurality of active electrodes may be structurally similar or dissimilar.

[0026] In one embodiment, a plurality of active electrodes are arranged substantially parallel to each other on an electrode support. In some embodiments, one or more of the plurality of active electrodes traverses a void in the electrode support. Typically, each of the plurality of active electrodes extends distally from a treatment surface of the electrode support. According to another aspect of the invention, the plurality of active electrodes may be oriented in a plurality of different directions with respect to the treatment surface. In one embodiment, a loop portion of each of the plurality of active electrodes is oriented in a different direction with respect to the treatment surface. In one embodiment, the orthogonal distance from the treatment surface to a distal face of each active electrode is substantially the same.

[0027] According to one aspect of the invention, a baffle or screen is provided at the distal end of the apparatus. In one embodiment the baffle is recessed within the void to impede the flow of solid material into the aspiration channel, and to trap the solid material in the vicinity of at least one of the plurality of active electrodes, whereby the trapped material may be readily digested.

[0028] In use, the plurality of active electrodes are coupled to a first pole of the high frequency power supply, and a return electrode is coupled to a second pole of the high frequency power supply for supplying high frequency alternating current to the device. Each of the plurality of active electrodes is capable of ablating tissue via a controlled ablation mechanism involving molecular dissociation of tissue components to yield low molecular weight ablation by-products. During this process, tissue fragments may be resected from the target site. Such resected tissue fragments may be digested by one or more of the plurality of active electrodes via essentially the same cool ablation mechanism as described above (i.e., involving molecular dissociation of tissue components), to form smaller tissue fragments and/or low molecular weight ablation by-products. The smaller tissue fragments and low molecular weight ablation by-products, together with any other unwanted materials (e.g., bodily fluids, extraneous saline) may be aspirated from the target site via the aspiration channel.

[0029] In another aspect, the present invention provides a method for removing tissue from a target site via an electro-surgical suction device, wherein a plurality of active electrodes are juxtaposed with the target tissue, and a high frequency voltage is applied to the plurality of active electrodes sufficient to ablate the tissue via localized molecular dissociation of tissue components. In one embodiment, the apparatus is adapted for efficiently ablating tissue and for rapidly removing unwanted materials, including resected tissue fragments, from the target site. In another aspect of the invention, the apparatus is adapted for providing a relatively smooth, even contour to a treated tissue.

[0030] In another aspect, the present invention provides an electro-surgical instrument or probe adapted for coupling to a high frequency power supply and for treating tissue at a target site. The instrument includes an electrode assembly including at least one active electrode disposed on an electrode support. In one embodiment, a plurality of active electrodes are arranged substantially parallel to each other on the electrode support.

[0031] According to another aspect of the invention, an electro-surgical instrument includes an electrode support having a treatment surface and a recess within the treatment surface, and each of a plurality of active electrodes spans or traverses the recess. In one embodiment, each of the plurality of active electrodes includes a bridge portion spaced from the treatment surface.

[0032] In another embodiment, an electrode support of an electro-surgical instrument includes a treatment surface and a recess within the treatment surface, wherein the recess includes a void therein, the void defining an aspiration port adapted for aspirating unwanted or excess materials from a surgical site during a procedure.

[0033] In another aspect, the present invention provides an electro-surgical instrument including a shaft, and an electrode assembly disposed at a distal end of the shaft. In one embodiment, the shaft includes an inner shaft and an outer shaft. According to one aspect of the invention, a proximal portion

of the inner shaft lies within a distal portion of the outer shaft. In one embodiment, the inner shaft comprises a metal tube or cylinder, while the outer shaft comprises an electrically insulating tube.

[0034] According to another aspect of the invention, there is provided an electro-surgical instrument including a shaft, having a shaft distal end and a shaft proximal end, and an integral fluid delivery element or unit. In one embodiment, the fluid delivery unit includes a plurality of fluid channels, each fluid channel defined jointly by an external groove in the shaft distal end and an inner surface of a sleeve, wherein the sleeve ensheathes a distal portion of the shaft.

[0035] In another aspect, the invention provides a method of treating tissue at a target site using an electro-surgical instrument having at least one active electrode disposed on an electrode support. The active electrode(s) is/are positioned in at least close proximity to the target tissue, and a high frequency voltage is applied between the active electrode(s) and a return electrode, wherein the applied voltage is effective in removing the target tissue in a controlled manner, such that underlying tissue exhibits little or no damage. According to one aspect of the invention, the instrument and method are adapted for laparoscopic procedures. In one embodiment, the method involves spot coagulation and/or ablation of endometrial implants, and the instrument is adapted for removing endometrial implants from delicate tissues or organs, such as the bowel, ureter, and ovaries.

[0036] A further understanding of the nature and advantages of the invention will become apparent by reference to the remaining portions of the specification and drawings.

BRIEF DESCRIPTION OF THE DRAWINGS

[0037] FIG. 1 is a perspective view of an electro-surgical system incorporating a power supply and an electro-surgical probe for tissue ablation, resection, incision, contraction and for vessel hemostasis according to the present invention;

[0038] FIG. 2 is a perspective view of another electro-surgical system incorporating a power supply, an electro-surgical probe and a supply of electrically conductive fluid for delivering the fluid to the target site;

[0039] FIG. 3 is a side view of another electro-surgical probe according to the present invention incorporating aspiration electrodes for ablating aspirated tissue fragments and/or tissue strands, such as synovial tissue;

[0040] FIG. 4 is an exploded view of a proximal portion of the electro-surgical probe;

[0041] FIG. 5 is a perspective view of another embodiment of the present invention;

[0042] FIG. 6 is a side-cross-sectional view of the electro-surgical probe of FIG. 5;

[0043] FIG. 7 is an enlarged detailed cross-sectional view of the distal end portion of the probe of FIG. 5;

[0044] FIGS. 8 and 9 show the proximal end and the distal end, respectively, of the probe of FIG. 5;

[0045] FIG. 10 illustrates a method for removing fatty tissue from the abdomen, groin or thigh region of a patient according to the present invention;

[0046] FIG. 11 illustrates a method for removing fatty tissue in the head and neck region of a patient according to the present invention.

[0047] FIG. 12 shows an electro-surgical probe including a resection unit, according to another embodiment of the invention;

[0048] FIG. 13 shows a resection unit of an electrosurgical probe, the resection unit including a resection electrode on a resection electrode support;

[0049] FIGS. 14A-D each show an electrosurgical probe including a resection unit, according to various embodiments of the invention;

[0050] FIG. 15A shows an electrosurgical probe including a resection unit and an aspiration device, according to the invention;

[0051] FIG. 15B shows an electrosurgical probe including a resection unit and a fluid delivery device, according to one embodiment of the invention;

[0052] FIGS. 16A-F each show a resection unit having at least one resection electrode head arranged on a resection electrode support, according to various embodiments of the invention;

[0053] FIG. 17 illustrates an arrangement of a resection electrode head with respect to the longitudinal axis of a resection unit;

[0054] FIG. 18A shows, in plan view, a resection electrode support disposed on a shaft distal end of an electrosurgical probe;

[0055] FIGS. 18B-D each show a profile of a resection electrode head on a resection electrode support;

[0056] FIGS. 19A-I each show a cross-section of a resection electrode head, according to one embodiment of the invention, as seen along the lines 19A-I of FIG. 18B;

[0057] FIG. 20 schematically represents a surgical kit for resection and ablation of tissue, according to another embodiment of the invention;

[0058] FIGS. 21A-B schematically represent a method of performing a resection and ablation electrosurgical procedure, according to another embodiment of the invention;

[0059] FIG. 22 schematically represents a method of making a resection and ablation electrosurgical probe, according to yet another embodiment of the invention;

[0060] FIGS. 23A and 23B show a side view and an end-view, respectively, of an electrosurgical suction apparatus, according to another embodiment of the invention;

[0061] FIG. 23C shows a longitudinal cross-section of the apparatus of FIGS. 23A, 23B;

[0062] FIG. 24A shows a longitudinal cross-section of the shaft distal end of an electrosurgical suction apparatus, according to the invention;

[0063] FIG. 24B shows a transverse cross-sectional view of an active electrode of the apparatus of FIG. 24A as taken along the lines 24B-24B;

[0064] FIG. 24C shows an active electrode in communication with an electrode lead;

[0065] FIG. 25A shows an electrosurgical suction apparatus having an outer sheath, according to another embodiment of the invention;

[0066] FIG. 25B shows a transverse cross-section of the apparatus of FIG. 25A;

[0067] FIG. 26A shows a longitudinal cross-section of the shaft distal end of an electrosurgical suction apparatus having a baffle, and FIG. 26B is an end view of the apparatus of FIG. 26A, according to another embodiment of the invention;

[0068] FIGS. 27A and 27B each show a longitudinal cross-section of the shaft distal end of an electrosurgical suction apparatus, according to two different embodiments of the invention;

[0069] FIGS. 28A and 28B show a perspective view and a side view, respectively, of the shaft distal end of an electrosurgical suction apparatus, according to another embodiment of the invention;

[0070] FIG. 29 is a block diagram schematically representing an electrosurgical system, according to one embodiment of the invention;

[0071] FIG. 30 is a block diagram schematically representing an electrosurgical instrument including an electrode assembly, according to one aspect of the invention;

[0072] FIG. 31 is a block diagram schematically representing an active electrode for an electrosurgical instrument, according to another embodiment of the invention;

[0073] FIG. 32 schematically represents an electrosurgical instrument as seen in side view, according to another aspect of the invention;

[0074] FIGS. 33A and 33B are a side view and a cross-sectional view, respectively, of the distal end portion of an electrosurgical instrument having a fluid delivery element, according to the invention;

[0075] FIG. 34A is a side view of an electrosurgical instrument, according to one embodiment of the invention;

[0076] FIG. 34B is a side view of the working or distal end of the instrument of FIG. 34A;

[0077] FIG. 34C shows the working end of the instrument, as seen along the lines 34C-34C of FIG. 34B;

[0078] FIG. 34D shows a distal portion of the bridge portion of an active electrode as seen along the lines 34D-34D of FIG. 34C;

[0079] FIG. 34E is a perspective view of the working end of the instrument of FIG. 34A, with the electrode(s) omitted for the sake of clarity;

[0080] FIG. 35 is a face view of an electrode assembly of an electrosurgical instrument illustrating the configuration of a plurality of active electrodes in relation to an electrode support, according to another embodiment of the invention;

[0081] FIG. 36 is a side view of a working or distal end of an electrosurgical instrument showing an active electrode protruding from a surface of an electrode support, according to another embodiment of the invention;

[0082] FIG. 37 is a perspective view of an electrode support of an electrosurgical instrument, showing a plurality of active electrodes on a treatment surface of the electrode support; and

[0083] FIG. 38 schematically represents a series of steps involved in a method of treating a target tissue during a surgical procedure, according to another embodiment of the invention.

DESCRIPTION OF SPECIFIC EMBODIMENTS

[0084] The present invention provides systems and methods for selectively applying electrical energy to a target location within or on a patient's body. The present invention is particularly useful in laparoscopic procedures, such as procedures for the treatment of endometriosis, and in laparoscopic oncology. In addition, tissues which may be treated by the system and method of the present invention include, but are not limited to, prostate tissue and leiomyomas (fibroids) located within the uterus, gingival tissues and mucosal tissues located in the mouth, tumors, scar tissue, myocardial tissue, collagenous tissue within the eye or epidermal and dermal tissues on the surface of the skin. Other procedures for which the present invention may be used include arthroscopic procedures, laminectomy/discectomy procedures for treating herniated disks, decompressive laminectomy for stenosis in

the lumbosacral and cervical spine, posterior lumbosacral and cervical spine fusions, treatment of scoliosis associated with vertebral disease, foraminotomies to remove the roof of the intervertebral foramina to relieve nerve root compression, as well as anterior cervical and lumbar discectomies. The present invention is also useful for resecting tissue within accessible sites of the body that are suitable for electrode loop resection, such as the resection of prostate tissue, leiomyomas (fibroids) located within the uterus, and other diseased or abnormal tissue within the body.

[0085] The present invention may also be used to treat tissue or organs of the head and neck, such as the ear, mouth, pharynx, larynx, esophagus, nasal cavity and sinuses. Such procedures may be performed through the mouth or nose using speculae or gags, or using endoscopic techniques, such as functional endoscopic sinus surgery (FESS). These procedures may include the removal of swollen tissue, chronically-diseased inflamed and hypertrophic mucous linings, polyps and/or neoplasms from the various anatomical sinuses of the skull, the turbinates and nasal passages, in the tonsil, adenoid, epi-glottic and supra-glottic regions, salivary glands, and other tissues; submucous resection of the nasal septum; and excision of diseased tissue, and the like. In other procedures, the present invention may be useful for collagen shrinkage, ablation, and/or hemostasis in procedures for treating snoring and obstructive sleep apnea (e.g., soft palate, such as the uvula, or tongue/pharynx stiffening, and midline glossectomies); for gross tissue removal, such as tonsillectomies, adenoidectomies, tracheal stenosis and vocal cord polyps and lesions; or for the resection or ablation of facial tumors or tumors within the mouth and pharynx, such as glossectomies, laryngectomies, acoustic neuroma procedures; and nasal ablation procedures. In addition, the present invention may also be used for procedures within the ear, such as stapedotomies, tympanotomies, or the like.

[0086] The present invention may also be useful for cosmetic and plastic surgery procedures in the head and neck. For example, the present invention may be used for ablation and sculpting of cartilage tissue, such as the cartilage within the nose that is sculpted during rhinoplasty procedures. The present invention may also be employed for skin tissue removal and/or collagen shrinkage in the epidermis or dermis tissue in the head and neck, e.g., the removal of pigmentations, vascular lesions (e.g., leg veins), scars, tattoos, etc., and for other surgical procedures on the skin, such as tissue rejuvenation, cosmetic eye procedures (blepharoplasties), wrinkle removal, tightening muscles for facelifts or browlifts, hair removal and/or transplant procedures, etc.

[0087] For convenience, certain embodiments of the invention will be described primarily with respect to the treatment of endometrial implants; resection and/or ablation of the meniscus and the synovial tissue within a joint during an arthroscopic procedure; and to the ablation, resection and/or aspiration of sinus tissue during an endoscopic sinus surgery procedure. However, it will be appreciated that the systems, apparatus, and methods of the invention may also be applied to procedures involving other tissues or organs of the body, including open procedures, intravascular procedures, urological procedures, laparoscopy, arthroscopy, thoracoscopy or other cardiac procedures, dermatology, orthopedics, gynecology, otorhinolaryngology, spinal and neurologic procedures, oncology, and the like.

[0088] In the present invention, high frequency (RF) electrical energy is applied to one or more active electrodes in the

presence of electrically conductive fluid to remove and/or modify a target tissue or organ. Depending on the specific procedure, the present invention may be used to: (1) volumetrically remove tissue, bone or cartilage (i.e., ablate or effect molecular dissociation of the tissue structure); (2) cut or resect tissue; (3) shrink or contract collagen connective tissue; and/or (4) coagulate severed blood vessels.

[0089] In one aspect of the invention, systems and methods are provided for the volumetric removal or ablation of tissue structures. In these procedures, a high frequency voltage difference is applied between one or more active electrode(s) and one or more return electrode(s) to develop high electric field intensities in the vicinity of the target tissue site. The high electric field intensities lead to electric field induced molecular breakdown of target tissue through molecular dissociation (rather than thermal evaporation or carbonization). Applicant believes that the tissue structure is volumetrically removed through molecular disintegration of larger organic molecules into smaller molecules and/or atoms, such as hydrogen, oxides of carbon, hydrocarbons and nitrogen compounds. This molecular disintegration completely removes the tissue structure, as opposed to dehydrating the tissue material by the removal of liquid from within the cells of the tissue, as is typically the case with electrosurgical desiccation and vaporization.

[0090] The high electric field intensities may be generated by applying a high frequency voltage that is sufficient to vaporize an electrically conductive fluid over at least a portion of the active electrode(s) in the region between the distal tip of the active electrode(s) and the target tissue. The electrically conductive fluid may be a gas or liquid, such as isotonic saline, delivered to the target site, or a viscous fluid, such as a gel, that is located at the target site. In the latter embodiment, the active electrode(s) are submersed in the electrically conductive gel during the surgical procedure. Since the vapor layer or vaporized region has a relatively high electrical impedance, it minimizes the current flow into the electrically conductive fluid. This ionization, under optimal conditions, induces the discharge of energetic electrons and photons from the vapor layer to the surface of the target tissue. A more detailed description of this cold ablation phenomenon, termed Coblation[®], can be found in commonly assigned U.S. Pat. No. 5,683,366 the complete disclosure of which is incorporated herein by reference.

[0091] In one embodiment, the present invention applies high frequency (RF) electrical energy in an electrically conductive fluid environment to remove (i.e., resect, cut, or ablate) or contract a tissue structure, and to seal transected vessels within the region of the target tissue. The present invention may be used for sealing larger arterial vessels, e.g., on the order of 1 mm in diameter or greater. In some embodiments, a high frequency power supply is provided having an ablation mode, wherein a first voltage is applied to an active electrode sufficient to effect molecular dissociation or disintegration of the tissue, and a coagulation (or sub-ablation) mode, wherein a second, lower voltage is applied to an active electrode (either the same or a different electrode) sufficient to achieve hemostasis of severed vessels within the tissue. In other embodiments, an electrosurgical probe is provided having one or more coagulation electrode(s) configured for sealing a severed vessel, such as an arterial vessel, and one or more active electrodes configured for either contracting the collagen fibers within the tissue or removing (ablating) the tissue, e.g., by applying sufficient energy to the tissue to effect

molecular dissociation. In the latter embodiments, the coagulation electrode(s) may be configured such that a single voltage can be applied to coagulate tissue with the coagulation electrode(s), and to ablate or contract the tissue with the active electrode(s). In other embodiments, the power supply is combined with the probe such that the coagulation electrode receives power when the power supply is in the coagulation mode (low voltage), and the active electrode(s) receive power when the power supply is in the ablation mode (higher voltage).

[0092] In a method according to one embodiment of the present invention, one or more active electrodes are brought into close proximity to tissue at a target site, and the power supply is activated in the ablation mode such that sufficient voltage is applied between the active electrodes and the return electrode to volumetrically remove the tissue through molecular dissociation, as described below. During this process, vessels within the tissue will be severed. Smaller vessels will be automatically sealed with the system and method of the present invention. Larger vessels, and those with a higher flow rate, such as arterial vessels, may not be automatically sealed in the ablation mode. In these cases, the severed vessels may be sealed by activating a control (e.g., a foot pedal) to reduce the voltage of the power supply and to convert the system into the coagulation mode. In this mode, the active electrodes may be pressed against the severed vessel to provide sealing and/or coagulation of the vessel. Alternatively, a coagulation electrode located on the same or a different probe may be pressed against the severed vessel. Once the vessel is adequately sealed, the surgeon activates a control (e.g., another foot pedal) to increase the voltage of the power supply and convert the system back into the ablation mode.

[0093] The present invention is also useful for removing or ablating tissue around nerves, such as spinal or cranial nerves, e.g., the olfactory nerve on either side of the nasal cavity, the optic nerve within the optic and cranial canals, and the palatine nerve within the nasal cavity, soft palate, uvula and tonsil, etc. One of the significant drawbacks with prior art microdebriders and lasers is that these devices do not differentiate between the target tissue and the surrounding nerves or bone. Therefore, the surgeon must be extremely careful during these procedures to avoid damage to the bone or nerves within and around the nasal cavity. In the present invention, the Coblation® process for removing tissue results in extremely small depths of collateral tissue damage as discussed above. This allows the surgeon to remove tissue close to a nerve without causing collateral damage to the nerve fibers.

[0094] In addition to the generally precise nature of the novel mechanisms of the present invention, applicant has discovered an additional method of ensuring that adjacent nerves are not damaged during tissue removal. According to the present invention, systems and methods are provided for distinguishing between the fatty tissue immediately surrounding nerve fibers and the normal tissue that is to be removed during the procedure. Peripheral nerves usually comprise a connective tissue sheath, or epineurium, enclosing the bundles of nerve fibers to protect these nerve fibers. This protective tissue sheath typically comprises a fatty tissue (e.g., adipose tissue) having substantially different electrical properties than the normal target tissue, such as the turbinates, polyps, mucous tissue or the like, that are, for example, removed from the nose during sinus procedures. The system of the present invention measures the electrical properties of

the tissue at the tip of the probe with one or more active electrode(s). These electrical properties may include electrical conductivity at one, several or a range of frequencies (e.g., in the range from 1 kHz to 100 MHz), dielectric constant, capacitance or combinations of these. In this embodiment, an audible signal may be produced when the sensing electrode (s) at the tip of the probe detects the fatty tissue surrounding a nerve, or direct feedback control can be provided to only supply power to the active electrode(s), either individually or to the complete array of electrodes, if and when the tissue encountered at the tip or working end of the probe is normal tissue based on the measured electrical properties.

[0095] In one embodiment, the current limiting elements (discussed in detail below) are configured such that the active electrodes will shut down or turn off when the electrical impedance of tissue at the tip of the probe reaches a threshold level. When this threshold level is set to the impedance of the fatty tissue surrounding nerves, the active electrodes will shut off whenever they come in contact with, or in close proximity to, nerves. Meanwhile, the other active electrodes, which are in contact with or in close proximity to nasal tissue, will continue to conduct electric current to the return electrode. This selective ablation or removal of lower impedance tissue in combination with the Coblation® mechanism of the present invention allows the surgeon to precisely remove tissue around nerves or bone.

[0096] In addition to the above, applicant has discovered that the Coblation® mechanism of the present invention can be manipulated to ablate or remove certain tissue structures, while having little effect on other tissue structures. As discussed above, the present invention uses a technique of vaporizing electrically conductive fluid to form a plasma layer or pocket around the active electrode(s), and then inducing the discharge of energy from this plasma or vapor layer to break the molecular bonds of the tissue structure. Based on initial experiments, applicants believe that the free electrons within the ionized vapor layer are accelerated in the high electric fields near the electrode tip(s). When the density of the vapor layer (or within a bubble formed in the electrically conductive liquid) becomes sufficiently low (i.e., less than approximately 10^{20} atoms/cm³ for aqueous solutions), the electron mean free path increases to enable subsequently injected electrons to cause impact ionization within these regions of low density (i.e., vapor layers or bubbles). Energy evolved by the energetic electrons (e.g., 4 to 5 eV) can subsequently bombard a molecule and break its bonds, dissociating a molecule into free radicals, which then combine to form gaseous or liquid Coblation® by-products.

[0097] The energy evolved by the energetic electrons may be varied by adjusting a variety of factors, such as: the number of active electrodes; electrode size and spacing; electrode surface area; asperities and sharp edges on the electrode surfaces; electrode materials; applied voltage and power; current limiting means, such as inductors; electrical conductivity of the fluid in contact with the electrodes; density of the fluid; and other factors. Accordingly, these factors can be manipulated to control the energy level of the excited electrons. Since different tissue structures have different molecular bonds, the present invention can be configured to break the molecular bonds of certain tissue, while having too low an energy to break the molecular bonds of other tissue. For example, components of adipose tissue have double bonds that require a substantially higher energy level than 4 to 5 eV to break. Accordingly, the present invention in its current configuration

generally does not ablate or remove such fatty tissue. However, the present invention may be used to effectively ablate cells to release the inner fat content in a liquid form. Of course, factors may be changed such that these double bonds can be broken (e.g., increasing the voltage or changing the electrode configuration to increase the current density at the electrode tips).

[0098] In another aspect of the invention, a loop electrode is employed to resect, shape or otherwise remove tissue fragments from the treatment site, and one or more active electrodes are employed to ablate (i.e., break down the tissue by processes including molecular dissociation or disintegration) the non-ablated tissue fragments in situ. Once a tissue fragment is cut, partially ablated or resected by the loop electrode, one or more active electrodes will be brought into close proximity to these fragments (either by moving the probe into position, or by drawing the fragments to the active electrodes with a suction lumen). Voltage is applied between the active electrodes and the return electrode to volumetrically remove the fragments through molecular dissociation, as described above. The loop electrode and the active electrodes are preferably electrically isolated from each other such that, for example, current can be limited (passively or actively) or completely interrupted to the loop electrode as the surgeon employs the active electrodes to ablate tissue fragments (and vice versa).

[0099] In another aspect of the invention, the loop electrode(s) are employed to ablate tissue using the Coblation® mechanisms described above. In these embodiments, the loop electrode(s) provides a relatively uniform smooth cutting or ablation effect across the tissue. In addition, loop electrodes generally have a larger surface area exposed to electrically conductive fluid (as compared to the smaller active electrodes described above), which increases the rate of ablation of tissue. Preferably, the loop electrode(s) extend a sufficient distance from the electrode support member selected to achieve a desirable ablation rate, while minimizing power dissipation into the surrounding medium (which could cause undesirable thermal damage to surrounding or underlying tissue). In an exemplary embodiment, the loop electrode has a length from one end to the other end of about 0.5 to 20 mm, usually about 1 to 8 mm. The loop electrode usually extends about 0.25 to 10 mm from the distal end of the support member, preferably about 1 to 4 mm.

[0100] The loop electrode(s) may have a variety of cross-sectional shapes. Electrode shapes according to the present invention can include the use of formed wire (e.g., by drawing round wire through a shaping die) to form electrodes with a variety of cross-sectional shapes, such as square, rectangular, L or V shaped, or the like. Electrode edges may also be created by removing a portion of the elongate metal electrode to reshape the cross-section. For example, material can be removed along the length of a solid or hollow wire electrode to form D or C shaped wires, respectively, with edges facing in the cutting direction. Alternatively, material can be removed at closely spaced intervals along the electrode length to form transverse grooves, slots, threads or the like along the electrodes.

[0101] In some embodiments, the loop electrode(s) will have a "non-active" portion or surface to selectively reduce undesirable current flow from the non-active portion or surface into tissue or surrounding electrically conductive liquids (e.g., isotonic saline, blood, or blood/non-conducting irrigant mixtures). Preferably, the "non-active" electrode portion will

be coated with an electrically insulating material. This can be accomplished, for example, with plasma deposited coatings of an insulating material, thin-film deposition of an insulating material using evaporative or sputtering techniques (e.g., SiO₂ or Si₃N₄), dip coating, or by providing an electrically insulating support member to electrically insulate a portion of the external surface of the electrode. The electrically insulated non-active portion of the active electrode(s) allows the surgeon to selectively resect and/or ablate tissue, while minimizing necrosis or ablation of surrounding non-target tissue or other body structures.

[0102] In addition, the loop electrode(s) may comprise a single electrode extending from first and second ends to an insulating support in the shaft, or multiple, electrically isolated electrodes extending around the loop. One or more return electrodes may also be positioned along the loop portion. Further descriptions of these configurations can be found in U.S. application Ser. No. 08/687,792, filed on Jul. 18, 1996, now U.S. Pat. No. 5,843,019, which as already been incorporated herein by reference.

[0103] The electrosurgical probe will comprise a shaft or a handpiece having a proximal end and a distal end which supports one or more active electrode(s). The shaft or handpiece may assume a wide variety of configurations, with the primary purpose being to mechanically support the active electrode and permit the treating physician to manipulate the electrode from a proximal end of the shaft. The shaft may be rigid or flexible, with flexible shafts optionally being combined with a generally rigid external tube for mechanical support. The distal portion of the shaft may comprise a flexible material, such as plastics, malleable stainless steel, etc, so that the physician can mold the distal portion into different configurations for different applications. Flexible shafts may be combined with pull wires, shape memory actuators, and other known mechanisms for effecting selective deflection of the distal end of the shaft to facilitate positioning of the electrode array. The shaft will usually include a plurality of wires or other conductive elements running axially throughout to permit connection of the electrode array to a connector at the proximal end of the shaft. Thus, the shaft will typically have a length of at least 5 cm for oral procedures and at least 10 cm, more typically being 20 cm, or longer for endoscopic procedures. The shaft will typically have a diameter of at least 0.5 mm and frequently in the range of from about 1 to 10 mm. Of course, for dermatological procedures on the outer skin, the shaft may have any suitable length and diameter that would facilitate handling by the surgeon.

[0104] For procedures within the nose and joints, the shaft will have a suitable diameter and length to allow the surgeon to reach the target by delivering the probe shaft through a percutaneous opening in the patient (e.g., a portal formed in the joint in arthroscopic surgery, or through one of the patient's nasal passages in FESS). Thus, the shaft will usually have a length in the range of from about 5 to 25 cm, and a diameter in the range of from about 0.5 to 5 mm. For procedures requiring the formation of a small hole or channel in tissue, such as treating swollen turbinates, the shaft diameter will usually be less than 3 mm, preferably less than about 1 mm. Likewise, for procedures in the ear, the shaft should have a length in the range of about 3 to 20 cm, and a diameter of about 0.3 to 5 mm. For procedures in the mouth or upper throat, the shaft will have any suitable length and diameter that would facilitate handling by the surgeon. For procedures in the lower throat, such as laryngectomies, the shaft will be

suitably designed to access the larynx. For example, the shaft may be flexible, or have a distal bend to accommodate the bend in the patient's throat. In this regard, the shaft may be a rigid shaft having a specifically designed bend to correspond with the geometry of the mouth and throat, or it may have a flexible distal end, or it may be part of a catheter. In any of these embodiments, the shaft may also be introduced through rigid or flexible endoscopes. Specific shaft designs will be described in detail in connection with the figures hereinafter.

[0105] The current flow path between the active electrode(s) and the return electrode(s) may be generated by submerging the tissue site in an electrically conductive fluid (e.g., a viscous fluid, such as an electrically conductive gel), or by directing an electrically conductive fluid along a fluid path to the target site (i.e., a liquid, such as isotonic saline, or a gas, such as argon). This latter method is particularly effective in a dry environment (i.e., the tissue is not submerged in fluid) because the electrically conductive fluid provides a suitable current flow path from the active electrode to the return electrode. A more complete description of an exemplary method of directing electrically conductive fluid between the active and return electrodes is described in commonly assigned U.S. patent application Ser. No. 08/485,219, filed Jun. 7, 1995, now U.S. Pat. No. 5,697,281, the contents of which are incorporated by reference herein in their entirety for all purposes.

[0106] In some procedures, it may also be necessary to retrieve or aspirate the electrically conductive fluid after it has been directed to the target site. For example, in procedures in the nose, mouth or throat, it may be desirable to aspirate the fluid so that it does not flow down the patient's throat. In addition, it may be desirable to aspirate small pieces of tissue that are not completely disintegrated by the high frequency energy, air bubbles, or other fluids at the target site, such as blood, mucus, the gaseous products of ablation, etc. Accordingly, the system of the present invention can include a suction lumen in the probe, or on another instrument, for aspirating fluids from the target site.

[0107] In some embodiments, the probe will include one or more aspiration electrode(s) coupled to the distal end of the suction lumen for ablating, or at least reducing the volume of, tissue fragments that are aspirated into the lumen. The aspiration electrode(s) function mainly to inhibit clogging of the lumen that may otherwise occur as larger tissue fragments are drawn therein. The aspiration electrode(s) may be different from the ablation active electrode(s), or the same electrode(s) may serve both functions. In some embodiments, the probe will be designed to use suction force to draw loose tissue, such as synovial tissue to the aspiration or ablation electrode(s) on the probe, which are then energized to ablate the loose tissue.

[0108] In other embodiments, the aspiration lumen can be positioned proximal of the active electrodes a sufficient distance such that the aspiration lumen will primarily aspirate air bubbles and body fluids such as blood, mucus, or the like. Such a configuration allows the electrically conductive fluid to dwell at the target site for a longer period. Consequently, the plasma can be created more aggressively at the target site and the tissue can be treated in a more efficient manner. Additionally, by positioning the aspiration lumen opening somewhat distant from the active electrodes, it may not be necessary to have ablation electrodes at the lumen opening since, in this configuration, tissue fragments will typically not be aspirated through the lumen.

[0109] The present invention may use a single active electrode or an electrode array distributed over a contact surface

of a probe. In the latter embodiment, the electrode array usually includes a plurality of independently current-limited and/or power-controlled active electrodes to apply electrical energy selectively to the target tissue while limiting the unwanted application of electrical energy to the surrounding tissue and environment. Such unwanted application of electrical energy results from power dissipation into surrounding electrically conductive liquids, such as blood, normal saline, electrically conductive gel and the like. The active electrodes may be independently current-limited by isolating the terminals from each other and connecting each terminal to a separate power source that is isolated from the other active electrodes. Alternatively, the active electrodes may be connected to each other at either the proximal or distal ends of the probe to form a single connector that couples to a power source.

[0110] In one configuration, each individual active electrode in the electrode array is electrically insulated from all other active electrodes in the array within the probe and is connected to a power source which is isolated from each of the other active electrodes in the array or to circuitry which limits or interrupts current flow to the active electrode when low resistivity material (e.g., blood, electrically conductive saline irrigant or electrically conductive gel) causes a lower impedance path between the return electrode and the individual active electrode. The isolated power sources for each individual active electrode may be separate power supply circuits having internal impedance characteristics which limit power to the associated active electrode when a low impedance return path is encountered. By way of example, the isolated power source may be a user selectable constant current source. In this embodiment, lower impedance paths will automatically result in lower resistive heating levels since the heating is proportional to the square of the operating current times the impedance. Alternatively, a single power source may be connected to each of the active electrodes through independently actuatable switches, or by independent current limiting elements, such as inductors, capacitors, resistors and/or combinations thereof. The current limiting elements may be provided in the probe, connectors, cable, controller, or along the conductive path from the controller to the distal tip of the probe. Alternatively, the resistance and/or capacitance may occur on the surface of the active electrode(s) due to oxide layers which form selected active electrodes (e.g., titanium or a resistive coating on the surface of metal, such as platinum).

[0111] The tip region of the probe may comprise many independent active electrodes designed to deliver electrical energy in the vicinity of the tip. The selective application of electrical energy to the conductive fluid is achieved by connecting each individual active electrode and the return electrode to a power source having independently controlled or current limited channels. The return electrode(s) may comprise a single tubular member of conductive material proximal to the electrode array at the tip which also serves as a conduit for the supply of the electrically conductive fluid between the active and return electrodes. Alternatively, the probe may comprise an array of return electrodes at the distal tip of the probe (together with the active electrodes) to maintain the electric current at the tip. The application of high frequency voltage between the return electrode(s) and the electrode array results in the generation of high electric field intensities at the distal tips of the active electrodes with conduction of high frequency current from each individual active electrode to the return electrode. The current flow from each

individual active electrode to the return electrode(s) is controlled by either active or passive means, or a combination thereof, to deliver electrical energy to the surrounding conductive fluid while minimizing energy delivery to surrounding (non-target) tissue.

[0112] The application of a high frequency voltage between the return electrode(s) and the active electrode(s) for appropriate time intervals effects cutting, removing, ablating, shaping, contracting or otherwise modifying the target tissue. The tissue volume over which energy is dissipated (i.e., over which a high current density exists) may be precisely controlled, for example, by the use of a multiplicity of small active electrodes whose effective diameters or principal dimensions range from about 5 mm to 0.01 mm, preferably from about 2 mm to 0.05 mm, and more preferably from about 1 mm to 0.1 mm. In these embodiments, electrode areas for both circular and non-circular terminals will have a contact area (per active electrode) below 25 mm², preferably being in the range from 0.0001 mm² to 1 mm², and more preferably from 0.005 mm² to 0.5 mm². The circumscribed area of the electrode array is in the range from 0.25 mm² to 75 mm², preferably from 0.5 mm² to 40 mm², and will usually include at least two isolated active electrodes, preferably at least five active electrodes, often greater than 10 active electrodes and even 50 or more active electrodes, disposed over the distal contact surfaces on the shaft. The use of small diameter active electrodes increases the electric field intensity and reduces the extent or depth of tissue heating as a consequence of the divergence of current flux lines which emanate from the exposed surface of each active electrode.

[0113] The area of the tissue treatment surface can vary widely, and the tissue treatment surface can assume a variety of geometries, with particular areas and geometries being selected for specific applications. Active electrode surfaces can have areas in the range from 0.25 mm² to 75 mm², usually being from about 0.5 mm² to 40 mm². The geometries can be planar, concave, convex, hemispherical, conical, linear "in-line" array or virtually any other regular or irregular shape. Most commonly, the active electrode(s) or active electrode(s) will be formed at the distal tip of the electrosurgical probe shaft, frequently being planar, disk-shaped, or hemispherical surfaces for use in reshaping procedures or being linear arrays for use in cutting. Alternatively or additionally, the active electrode(s) may be formed on lateral surfaces of the electrosurgical probe shaft (e.g., in the manner of a spatula), facilitating access to certain body structures in endoscopic procedures.

[0114] The electrically conductive fluid should have a threshold conductivity to provide a suitable conductive path between the active electrode(s) and the return electrode(s). The electrical conductivity of the fluid (in units of millisiemens per centimeter or mS/cm) will usually be greater than 0.2 mS/cm, preferably will be greater than 2 mS/cm and more preferably greater than 10 mS/cm. In an exemplary embodiment, the electrically conductive fluid is isotonic saline, which has a conductivity of about 17 mS/cm.

[0115] In some embodiments, the electrode support and the fluid outlet may be recessed from an outer surface of the probe or handpiece to confine the electrically conductive fluid to the region immediately surrounding the electrode support. In addition, the shaft may be shaped so as to form a cavity around the electrode support and the fluid outlet. This helps to assure that the electrically conductive fluid will remain in contact with the active electrode(s) and the return electrode(s)

to maintain the conductive path therebetween. In addition, this will help to maintain a vapor or plasma layer between the active electrode(s) and the tissue at the treatment site throughout the procedure, which reduces the thermal damage that might otherwise occur if the vapor layer were extinguished due to a lack of conductive fluid. Provision of the electrically conductive fluid around the target site also helps to maintain the tissue temperature at desired levels.

[0116] The voltage applied between the return electrode(s) and the electrode array will be at high or radio frequency, typically between about 5 kHz and 20 MHz, usually being between about 30 kHz and 2.5 MHz, preferably between about 50 kHz and 500 kHz, more preferably less than 350 kHz, and most preferably between about 100 kHz and 200 kHz. The RMS (root mean square) voltage applied will usually be in the range from about 5 volts to 1000 volts, preferably being in the range from about 10 volts to 500 volts depending on the active electrode size, the operating frequency and the operation mode of the particular procedure or desired effect on the tissue (i.e., contraction, coagulation or ablation). Typically, the peak-to-peak voltage will be in the range of 10 to 2000 volts, preferably in the range of 20 to 1200 volts and more preferably in the range of about 40 to 800 volts (again, depending on the electrode size, the operating frequency and the operation mode).

[0117] As discussed above, the voltage is usually delivered in a series of voltage pulses or alternating current of time varying voltage amplitude with a sufficiently high frequency (e.g., on the order of 5 kHz to 20 MHz) such that the voltage is effectively applied continuously (as compared with e.g., lasers claiming small depths of necrosis, which are generally pulsed at about 10 to 20 Hz). In addition, the duty cycle (i.e., cumulative time in any one-second interval that energy is applied) is on the order of about 50% for the present invention, as compared with pulsed lasers which typically have a duty cycle of about 0.0001%.

[0118] The preferred power source of the present invention delivers a high frequency current selectable to generate average power levels ranging from several milliwatts to tens of watts per electrode, depending on the volume of target tissue being heated, and/or the maximum allowed temperature selected for the probe tip. The power source allows the user to select the voltage level according to the specific requirements of a particular FESS procedure, arthroscopic surgery, dermatological procedure, ophthalmic procedures, open surgery or other endoscopic surgery procedure. A description of a suitable power source can be found in U.S. Patent Application No. 60/062,997, filed Oct. 23, 1997 (Attorney Docket No. A-05P), the complete disclosure of which has been incorporated herein by reference.

[0119] The power source may be current limited or otherwise controlled so that undesired heating of the target tissue or surrounding (non-target) tissue does not occur. In one embodiment of the present invention, current limiting inductors are placed in series with each independent active electrode, where the inductance of the inductor is in the range of 10uH to 50,000uH, depending on the electrical properties of the target tissue, the desired tissue heating rate, and the operating frequency. Alternatively, capacitor-inductor (LC) circuit structures may be employed, as described previously in co-pending PCT application No. PCT/US94/05168 (Attorney Docket No. A-01PC), the complete disclosure of which is incorporated herein by reference. Additionally, current limiting resistors may be selected. Preferably, these resistors will

have a large positive temperature coefficient of resistance so that, as the current level begins to rise for any individual active electrode in contact with a low resistance medium (e.g., saline irrigant or conductive gel), the resistance of the current limiting resistor increases significantly, thereby minimizing the power delivery from the active electrode into the low resistance medium (e.g., saline irrigant or conductive gel).

[0120] It should be clearly understood that the invention is not limited to electrically isolated active electrodes, or even to a plurality of active electrodes. For example, the array of active electrodes may be connected to a single lead that extends through the probe shaft to a power source of high frequency current. Alternatively, the probe may incorporate a single electrode that extends directly through the probe shaft or is connected to a single lead that extends to the power source. The active electrode may have a ball shape (e.g., for tissue vaporization and desiccation), a twizzle shape (for vaporization and needle-like cutting), a spring shape (for rapid tissue debulking and desiccation), a twisted metal shape, an annular or solid tube shape or the like. Alternatively, the electrode may comprise a plurality of filaments, a rigid or flexible brush electrode (for debulking a tumor, such as a fibroid, bladder tumor or a prostate adenoma), a side-effect brush electrode on a lateral surface of the shaft, a coiled electrode or the like. In one embodiment, the probe comprises a single active electrode that extends from an insulating member, e.g., ceramic, at the distal end of the probe. The insulating member is preferably a tubular structure that separates the active electrode from a tubular or annular return electrode positioned proximal to the insulating member and the active electrode.

[0121] Referring now to FIG. 2, an exemplary electrosurgical system 411 for treatment of tissue in 'dry fields' will now be described in detail. Of course, system 411 may also be used in a 'wet field', i.e., the target site is immersed in electrically conductive fluid. However, this system is particularly useful in 'dry fields' where the fluid is preferably delivered through an electrosurgical probe to the target site. As shown, electrosurgical system 411 generally comprises an electrosurgical handpiece or probe 410 connected to a power supply 428 for providing high frequency voltage to a target site and a fluid source 421 for supplying electrically conductive fluid 450 to probe 410. In addition, electrosurgical system 411 may include an endoscope (not shown) with a fiber optic head light for viewing the surgical site, particularly in sinus procedures or procedures in the ear or the back of the mouth. The endoscope may be integral with probe 410, or it may be part of a separate instrument. The system 411 may also include a vacuum source (not shown) for coupling to a suction lumen or tube in the probe 410 for aspirating the target site.

[0122] As shown, probe 410 generally includes a proximal handle 419 and an elongate shaft 418 having an array 412 of active electrodes 458 at its distal end. A connecting cable 434 has a connector 426 for electrically coupling the active electrodes 458 to power supply 428. The active electrodes 458 are electrically isolated from each other and each of the terminals 458 is connected to an active or passive control network within power supply 428 by means of a plurality of individually insulated conductors (not shown). A fluid supply tube 415 is connected to a fluid tube 414 of probe 410 for supplying electrically conductive fluid 450 to the target site.

[0123] Similar to the above embodiment, power supply 428 has an operator controllable voltage level adjustment 430 to change the applied voltage level, which is observable at a

voltage level display 432. Power supply 428 also includes first, second and third foot pedals 437, 438, 439 and a cable 436 which is removably coupled to power supply 428. The foot pedals 437, 438, 439 allow the surgeon to remotely adjust the energy level applied to active electrodes 458. In an exemplary embodiment, first foot pedal 437 is used to place the power supply into the ablation mode and second foot pedal 438 places power supply 428 into the "coagulation" mode. The third foot pedal 439 allows the user to adjust the voltage level within the "ablation" mode. In the ablation mode, a sufficient voltage is applied to the active electrodes to establish the requisite conditions for molecular dissociation of the tissue (i.e., vaporizing a portion of the electrically conductive fluid, ionizing charged particles within the vapor layer, and accelerating these charged particles against the tissue). As discussed above, the requisite voltage level for ablation will vary depending on the number, size, shape and spacing of the electrodes, the distance to which the electrodes extend from the support member, etc. Once the surgeon places the power supply in the ablation mode, voltage level adjustment 430 or third foot pedal 439 may be used to adjust the voltage level to adjust the degree or aggressiveness of the ablation.

[0124] Of course, it will be recognized that the voltage and modality of the power supply may be controlled by other input devices. However, applicant has found that foot pedals are convenient methods of controlling the power supply while manipulating the probe during a surgical procedure.

[0125] In the coagulation mode, the power supply 428 applies a low enough voltage to the active electrodes (or the coagulation electrode) to avoid vaporization of the electrically conductive fluid and subsequent molecular dissociation of the tissue. The surgeon may automatically toggle the power supply between the ablation and coagulation modes by alternately stepping on foot pedals 437, 438, respectively. This allows the surgeon to quickly move between coagulation and ablation in situ, without having to remove his/her concentration from the surgical field or without having to request an assistant to switch the power supply. By way of example, as the surgeon is sculpting soft tissue in the ablation mode, the probe typically will simultaneously seal and/or coagulate small severed vessels within the tissue. However, larger vessels, or vessels with high fluid pressures (e.g., arterial vessels) may not be sealed in the ablation mode. Accordingly, the surgeon can simply actuate foot pedal 438, automatically lowering the voltage level below the threshold level for ablation, and apply sufficient pressure onto the severed vessel for a sufficient period of time to seal and/or coagulate the vessel. After this is completed, the surgeon may quickly move back into the ablation mode by actuating foot pedal 437. A specific design of a suitable power supply for use with the present invention can be found in Provisional Patent Application No. 60/062,997 filed Oct. 23, 1997 (Attorney Docket No. 16238-007400), previously incorporated herein by reference.

[0126] FIGS. 3 and 4 illustrate an exemplary electrosurgical probe 490 constructed according to the principles of the present invention. As shown in FIG. 3, probe 490 generally includes an elongated shaft 500 which may be flexible or rigid, a handle 604 coupled to the proximal end of shaft 500 and an electrode support member 502 coupled to the distal end of shaft 500. Shaft 500 preferably includes a bend 501 that allows the distal section of shaft 500 to be offset from the proximal section and handle 604. This offset facilitates procedures that require an endoscope, such as FESS, because the endoscope can, for example, be introduced through the same

nasal passage as the shaft **500** without interference between handle **604** and the eyepiece of the endoscope. In one embodiment, shaft **500** preferably comprises a plastic material that is easily molded into the desired shape.

[0127] In an alternative embodiment (not shown), shaft **500** comprises an electrically conducting material, usually metal, which is selected from the group comprising tungsten, stainless steel alloys, platinum or its alloys, titanium or its alloys, molybdenum or its alloys, and nickel or its alloys. In this embodiment, shaft **500** includes an electrically insulating jacket **508** which is typically formed as one or more electrically insulating sheaths or coatings, such as polytetrafluoroethylene, polyimide, and the like. The provision of the electrically insulating jacket over the shaft prevents direct electrical contact between these metal elements and any adjacent body structure or the surgeon. Such direct electrical contact between a body structure (e.g., tendon) and an exposed electrode could result in unwanted heating and necrosis of the structure at the point of contact.

[0128] Handle **604** typically comprises a plastic material that is easily molded into a suitable shape for handling by the surgeon. Handle **604** defines an inner cavity (not shown) that houses the electrical connections **650** (FIG. 4), and provides a suitable interface for connection to an electrical connecting cable **422** (see FIG. 2). Electrode support member **502** extends from the distal end of shaft **500** (usually about 1 to 20 mm), and provides support for a plurality of electrically isolated active electrodes **504**. As shown in FIG. 3, a fluid tube **633** extends through an opening in handle **604**, and includes a connector **635** for connection to a fluid supply source, for supplying electrically conductive fluid to the target site. Depending on the configuration of the distal surface of shaft **500**, fluid tube **633** may extend through a single lumen (not shown) in shaft **500**, or it may be coupled to a plurality of lumens (also not shown) that extend through shaft **500** to a plurality of openings at its distal end. In the representative embodiment, fluid tube **633** extends along the exterior of shaft **500** to a point just proximal of return electrode **512**. In this embodiment, the fluid is directed through an opening **637** past return electrode **512** to the active electrodes **504**. Probe **490** may also include a valve **417** (FIG. 3) or equivalent structure for controlling the flow rate of the electrically conductive fluid to the target site.

[0129] In several variations of the invention, a return electrode is not directly connected to the active electrode or. To complete this current path so that active electrode(s) are electrically connected to return electrode, electrically conductive fluid (e.g., isotonic saline) is caused to flow therebetween. The electrically conductive fluid may be delivered through a fluid tube (see, e.g., FIG. 3, element **633**) to an opening near the distal end of the device. Alternatively, the fluid may be delivered by a fluid delivery element that is separate from probe. In arthroscopic surgery, for example, the joint cavity will be flooded with isotonic saline and the probe will be introduced into this flooded cavity. Electrically conductive fluid will be continually resupplied to maintain the conduction path between return electrode and active electrodes.

[0130] In alternative embodiments, the fluid path may be formed in probe by, for example, an inner lumen or an annular gap between the return electrode and a tubular support member within a shaft of the device. This annular gap may be formed near the perimeter of the shaft such that the electrically conductive fluid tends to flow radially inward towards the target site, or it may be formed towards the center of the

shaft so that the fluid flows radially outward. In both of these embodiments, a fluid source (e.g., a bag of fluid elevated above the surgical site or having a pumping device), is coupled to probe via a fluid supply tube that may or may not have a controllable valve. A more complete description of an electrosurgical probe incorporating one or more fluid lumen(s) can be found in parent patent application Ser. No. 08/485,219, filed on Jun. 7, 1995, now U.S. Pat. No. 5,697,281, the complete disclosure of which is incorporated herein by reference.

[0131] FIG. 4 illustrates the electrical connections **650** within handle **604** for coupling active electrodes **504** and return electrode **512** to the power supply **428**. As shown, a plurality of wires **652** extend through shaft **500** to couple terminals **504** to a plurality of pins **654**, which are plugged into a connector block **656** for coupling to a connecting cable **422** (FIG. 2). Similarly, return electrode **512** is coupled to connector block **656** via a wire **658** and a plug **660**. Alternatively, the device may have an integrated cable fixedly attached to the connections where the proximal portion of the cable (the end of the cable opposite to the device) contains connections allowing for coupling of the device to a power supply.

[0132] FIGS. 5-9 illustrate another embodiment of the present invention. As shown in FIG. 5, an electrosurgical probe **800** includes an elongated shaft **801** which may be flexible or rigid, a handle **804** coupled to the proximal end of shaft **801** and an electrode support member **802** coupled to the distal end of shaft **801**. As in previous embodiments, probe **800** includes an active loop electrode **803** (e.g., FIG. 7) and a return electrode **812** (not shown), the latter spaced proximally from active loop electrode **803**. The probe **800** further includes a suction lumen **820** (FIG. 6) for aspirating excess fluids, bubbles, tissue fragments, and/or products of ablation from the target site. As shown in FIGS. 6 and 9, suction lumen **820** extends through support member **802** to a distal opening **822**, and extends through shaft **801** and handle **804** to an external connector **824** for coupling to a vacuum source. Typically, the vacuum source is a standard hospital pump that provides suction pressure to connector **824** and lumen **820**.

[0133] As shown in FIG. 6, handle **804** defines an inner cavity **808** that houses the electrical connections **850** (discussed above), and provides a suitable interface for connection to an electrical connecting cable **22** (see FIG. 1). As shown in FIG. 8, the probe will also include a coding resistor **860** having a value selected to program different output ranges and modes of operation for the power supply. This allows a single power supply to be used with a variety of different probes in different applications (e.g., dermatology, cardiac surgery, neurosurgery, arthroscopy, etc).

[0134] Electrode support member **802** extends from the distal end of shaft **801** (usually about 1 to 20 mm), and provides support for loop electrode **803** and a ring electrode **804** (see FIG. 9). As shown in FIG. 7, loop electrode **803** has first and second ends extending from the electrode support member **802**. The first and second ends are each coupled to, or integral with, one or more connectors, e.g., wires (not shown), that extend through the shaft of the probe to its proximal end for coupling to the high frequency power supply. The loop electrode usually extends about 0.5 to about 10 mm from the distal end of support member, preferably about 1 to 2 mm. Loop electrode **803** usually extends further away from the support member than the ring electrode **804** to facilitate ablation of tissue. As discussed below, loop electrode **803** is

especially configured for tissue ablation, while the ring electrode **804** ablates tissue fragments that are aspirated into suction lumen **820**.

[0135] Referring to FIG. 9, ring electrode **804** preferably comprises a tungsten or titanium wire having two ends **830**, **832** coupled to electrical connectors (not shown) within support member **802**. The wire is bent to form one-half of a figure eight, thereby forming a ring positioned over opening **822** of suction lumen **820**. This ring inhibits passage of tissue fragments large enough to clog suction lumen **820**. Moreover, voltages applied between ring electrode **804** and return electrode **812** provide sufficient energy to ablate these tissue fragments into smaller fragments that are then aspirated through lumen **820**. In a presently preferred embodiment, ring electrode **804** and loop electrode **803** are electrically isolated from each other. However, electrodes **804**, **803** may be electrically coupled to each other in some applications.

[0136] The systems of the present invention may include a bipolar arrangement of electrodes designed to ablate tissue at the target site, and then aspirate tissue fragments, as described above. Alternatively, the instrument may also include a rotating shaft with a cutting tip for cutting tissue in a conventional manner. In this embodiment, the electrode(s) serve to effect hemostasis at the target site and to reduce clogging of the aspiration lumen, while the rotating shaft and cutting tip do the bulk of tissue removal by cutting the tissue in a conventional manner.

[0137] The system and method of the present invention may also be useful to efficaciously ablate (i.e., disintegrate) cancer cells and tissue containing cancer cells, such as cancer on the surface of the epidermis, eye, colon, bladder, cervix, uterus and the like. The present invention's ability to completely disintegrate the target tissue can be advantageous in this application because simply vaporizing and fragmenting cancerous tissue may lead to spreading of viable cancer cells (i.e., seeding) to other portions of the patient's body or to the surgical team in close proximity to the target tissue. In addition, the cancerous tissue can be removed to a precise depth while minimizing necrosis of the underlying tissue.

[0138] In another aspect, the present invention provides an electrosurgical probe having at least one active loop electrode for resecting and ablating tissue. In comparison to the planar electrodes, ball electrodes, or the like, the active loop electrodes provide a greater current concentration to the tissue at the target site. The greater current concentration can be used to aggressively create a plasma within the electrically conductive fluid, and hence a more efficient resection of the tissue at the target site. In use, the loop electrode(s) are typically employed to ablate tissue using the Coblation® mechanisms as described above. Voltage is applied between the active loop electrodes and a return electrode to volumetrically loosen fragments from the target site through molecular dissociation. Once the tissue fragments are loosened from the target site, the tissue fragments can be ablated in situ within the plasma (i.e., break down the tissue by processes including molecular dissociation or disintegration).

[0139] In some embodiments, the loop electrode(s) provide a relatively uniform smooth cutting or ablation effect across the tissue. The loop electrodes generally have a larger surface area exposed to electrically conductive fluid (as compared to the smaller active electrodes described above), which increases the rate of ablation of tissue.

[0140] Applicants have found that the current concentrating effects of the loop electrodes further provide reduced

current dissipation into the surrounding tissue, and consequently improved patient comfort through the reduced stimulation of surrounding nerves and muscle. Preferably, the loop electrode(s) extend a sufficient distance from the electrode support member to achieve current concentration and an improved ablation rate while simultaneously reducing current dissipation into the surrounding medium (which can cause undesirable muscle stimulation, nerve stimulation, or thermal damage to surrounding or underlying tissue). In an exemplary embodiment, the loop electrode has a length from one end to the other end of about 0.5 mm to 20 mm, usually about 1 mm to 8 mm. The loop electrode usually extends about 0.25 mm to 10 mm from the distal end of the support member, preferably about 1 mm to 4 mm.

[0141] The loop electrode(s) may have a variety of cross-sectional shapes. Electrode shapes according to the present invention can include the use of formed wire (e.g., by drawing round wire through a shaping die) to form electrodes with a variety of cross-sectional shapes, such as square, rectangular, L or V shaped, or the like. Electrode edges may also be created by removing a portion of the elongate metal electrode to reshape the cross-section. For example, material can be removed along the length of a solid or hollow wire electrode to form D or C shaped wires, respectively, with edges facing in the cutting direction. Alternatively, material can be removed at closely spaced intervals along the electrode length to form transverse grooves, slots, threads or the like along the electrodes.

[0142] In yet another aspect, the present invention provides an electrosurgical probe having an aspiration lumen with an opening that is spaced proximally from the active electrodes. Applicants have found that, by spacing the suction lumen opening proximal of the active electrodes, a more aggressive plasma can be created. In use, the saline is delivered to the target site and allowed to remain in contact with the electrodes and tissue for a longer period of time. By increasing the distance between the aspiration lumen and the conductive fluid, the dwell time of the conductive fluid is increased and the plasma can be aggressively created. Advantageously, by moving the aspiration lumen out of the target area, the suction will primarily aspirate blood and gas bubbles from the target site, while leaving the conductive fluid in the target area. Consequently, less conductive fluid and tissue fragments are aspirated from the target site and less clogging of the aspiration lumen occurs.

[0143] In a further aspect, the present invention provides an electrosurgical probe having a conductive fluid delivery lumen that has at least one distal opening positioned at least partially around the active electrodes. The configuration of the openings can be completely around the active electrodes (e.g., O configuration or annular shaped) or partially around the active electrodes (e.g., U configuration or C configuration) such that delivery of the conductive fluid immerses the active electrodes with conductive fluid during the ablation or resection procedure. Because the conductive fluid can be delivered from a plurality of directions, the dwell time of the conductive fluid is increased, and consequently the creation of the plasma can be improved.

[0144] In a preferred embodiment, the conductive fluid lumen comprises a plurality of openings that are positioned so as to substantially surround the active electrode array. As above, by "substantially surround", is meant that the openings are at least partially around the active electrodes. In some configurations, the openings will be equally spaced around

the active electrodes. However, it will be appreciated that in other alternative embodiments, the openings will only partially surround the active electrodes or can be unevenly spaced about the active electrodes.

[0145] With reference to FIGS. 12-19 there follows a description of an electrosurgical probe 1400 including a resection unit 1406, according to various embodiments of the instant invention. Probe 1400 is adapted for aggressive ablation, for resection, or for combined ablation and resection of tissue. Probe 1400 may be used in a broad range of surgical procedures including, without limitation, those listed or described hereinabove. In some embodiments, resection unit 1406 may be used to resect tissue by mechanical abrasion, cutting, or severing of tissue. In some embodiments, resection unit 1406 may be used to ablate tissue, e.g., via a Coblation® (cool ablation) mechanism. The Coblation® mechanism has been described hereinabove. Briefly, and without being bound by theory, Coblation® involves the localized generation of a plasma by the application of a high frequency voltage between at least one active electrode and a return electrode in the presence of an electrically conductive fluid. The plasma thus generated causes the breakdown of tissues, e.g., via molecular dissociation, to form low molecular weight ablation by-products. Such low molecular weight ablation by-products may be easily removed from a target site, e.g., via aspiration. Coblation® allows the controlled removal of tissue, in which both the quantity and quality of tissue removed can be accurately determined. In some embodiments, resection unit 1406 may be used for combined resection and ablation: to resect tissue by application of a mechanical force to the tissue and, concurrently therewith, to electrically ablate (“Coblate”) the tissue contacted by resection unit 1406. Applicants have found that a combination of mechanical resection and electrical ablation by resection unit 1406 provides advantageous tissue removal, as compared with mechanical resection or electrical ablation alone. Advantages of tissue removal by combined resection and ablation by resection unit 1406 include a more rapid and aggressive tissue removal, as compared with ablation alone; and a more controlled and less traumatic tissue removal, as compared with mechanical resection alone.

[0146] FIG. 12 shows probe 1400 including a shaft 1402 affixed at shaft proximal end portion 1402b to a handle 1404. Resection unit 1406 is disposed on shaft distal end portion 1402a. Although FIG. 12 shows only a single resection unit 1406 on shaft 1402, certain embodiments of the instant invention may include a plurality of resection units 1406 which may be alike or dissimilar in various respects (for example, the size and shape of electrode support 1408, and the number, arrangement, and type of resection electrodes 1410) (FIG. 13). In the embodiment of FIG. 12, a return electrode 1420 is located at shaft distal end portion 1402a. Return electrode 1420 may be in the form of an annular band. Resection unit 1406 is shown in FIG. 12 as being arranged within, or surrounded by, return electrode 1420. In other embodiments, resection unit 1406 may be arranged adjacent to return electrode 1420. Under the invention, shaft 1402 may be provided in a range of different lengths and diameters. Preferably, shaft 1402 has a length in the range of from about 5 cm to about 30 cm; more preferably in the range of from about 10 cm to about 25 cm. Preferably, shaft 1402 has a diameter in the range of from about 1 mm to about 20 mm; more preferably in the range of from about 2 mm to about 10 mm.

[0147] FIG. 13 schematically represents resection unit 1406 of probe 1400, wherein resection unit 1406 includes a resection electrode 1410 on a resection electrode support member 1408. In FIG. 13 resection electrode 1410 is represented as a single “box” located within support 1408, however, other arrangements and numbers of resection electrode 1410 are contemplated and are within the scope of the invention (see, for example, FIGS. 16A-F). Resection electrode support 1408 may comprise an electrically insulating, and durable or refractory material, such as a glass, a ceramic, a silicone, a polyurethane, a urethane, a polyimide, silicon nitride, teflon, or alumina, and the like. Resection electrode support 1408 is shown in FIG. 13 as being substantially square in outline, however, a broad range of other shapes are also possible. The size of resection electrode support 1408 may depend on a number of factors, including the diameter or width of shaft 1402. In one embodiment, support 1408 may be mounted laterally on shaft 1402 as an annular band, i.e., support 1408 may completely encircle shaft 1402. Typically support 1408 represents or occupies from about 2% to 100% of the circumference of shaft 1402. More typically, support 1408 occupies from about 50% to 80% of the circumference of shaft 1402, most typically from about 10% to 50% of the circumference of shaft 1402. In embodiments wherein support 1408 is mounted terminally on shaft 1402, support 1408 typically occupies from about 5% to 100% of the cross-sectional area of shaft 1402, more typically from about 10% to 95% of the cross-sectional area of shaft 1402.

[0148] FIGS. 14A-D each show an electrosurgical probe 1400, according to certain embodiments of the invention. Probe 1400 is depicted in FIGS. 14A-D as being linear, however, according to various embodiments of the invention, shaft 1402 may include one or more curves or bends therein (see, for example, FIGS. 34A-B). Resection electrodes 1410 are omitted from FIGS. 14A-D for the sake of clarity. However, as described elsewhere herein, each resection unit 1406 includes at least one resection electrode 1410 (see, for example, FIGS. 16A-F, 18A-D).

[0149] With reference to FIG. 14A, probe 1400 includes a fluid delivery tube 1434, and a fluid delivery port 1430 located distal to resection unit 1406 on shaft distal end portion 1402a. Fluid delivery port 1430 is coupled to fluid delivery tube 1434 via a fluid delivery lumen 1432 (FIG. 15B). Fluid delivery tube 1434 is, in turn, coupled to a source of an electrically conductive fluid (see, e.g., FIG. 2). Fluid delivery port 1430 is adapted to provide a quantity of an electrically conductive fluid to shaft distal end portion 1402a during a procedure, as is described elsewhere herein in enabling detail.

[0150] FIG. 14B shows probe 1400 including an aspiration tube 1444 and an aspiration port 1440 located proximal to resection unit 1406. In the embodiment depicted in FIG. 14B, aspiration tube 1444 is shown as being connected to probe 1400 at shaft proximal end 1402b, however other arrangements for coupling aspiration tube 1444 to probe 1400 are possible under the invention. FIG. 14C shows probe 1400 including both an aspiration tube 1444 and a fluid delivery tube 1434; and both a fluid delivery port 1430 and an aspiration port 1440. Although fluid delivery port 1430 is depicted in FIGS. 14A, 14C as a single port located distal to resection unit 1406, other arrangements of fluid delivery port(s) 1430/1430' with respect to resection unit 1406, are contemplated according to various embodiments of the invention. Aspiration port 1440 is located proximal to resection unit 1406. Preferably, aspiration port 1440 is located a distance of at

least 2 mm proximal to resection unit **1406**. More preferably, aspiration port **1440** is located a distance in the range of from about 4 mm to about 50 mm proximal to resection unit **1406**. In one embodiment, aspiration port **1440** may have a screen (not shown) to prevent relatively large fragments of resected tissue from entering aspiration lumen **1442** (FIG. **15A**). Such a screen may serve as an active electrode and cause ablation of tissue fragments which contact the screen. Alternatively, the screen may serve as a mechanical sieve or filter to exclude entry of relatively large tissue fragments into lumen **1442**.

[0151] FIG. **14D** shows probe **1400** in which resection unit **1406** is located at the distal terminus of shaft **1402**. In this embodiment, return electrode **1420** is located at shaft distal end **1402a**, and aspiration port **1440** is located proximal to return electrode **1420**. The embodiment of FIG. **14D** may further include one or more fluid delivery ports **1430** (see, for example, FIG. **15B**) for delivering an electrically conductive fluid to, at least, resection unit **1406**. In certain embodiments, fluid delivery port(s) **1430** deliver a quantity of an electrically conductive fluid to shaft distal end **1402a** sufficient to immerse resection unit **1406** and return electrode **1420**. In some embodiments, fluid delivery port(s) **1430** deliver a quantity of an electrically conductive fluid from shaft distal end **1402a** sufficient to immerse the tissue at a site targeted for ablation and/or resection.

[0152] FIG. **15A** shows electrosurgical probe **1400** including resection unit **1406** and aspiration port **1440** proximal to resection unit **1406**, according to one embodiment of the invention. Aspiration port **1440** is coupled to aspiration tube **1444** via an aspiration lumen **1442**. Aspiration tube **1444** may be coupled to a vacuum source, as is well known in the art. Aspiration lumen **1442** serves as a conduit for removal of unwanted materials (e.g., excess fluids and resected tissue fragments) from the surgical field or target site of an ablation and/or resection procedure, essentially as described hereinabove with reference to other embodiments of an electrosurgical probe. The embodiment of FIG. **15A** may further include a fluid delivery device (see, for example, FIG. **15B**).

[0153] FIG. **15B** shows electrosurgical probe **1400** including resection unit **1406** and fluid delivery port **1430** located distal to resection unit **1406**, according to one embodiment of the invention. Fluid delivery port **1430** is coupled to fluid delivery tube **1434** via a fluid delivery lumen **1432**. Fluid delivery lumen **1432** serves as a conduit for providing a quantity of an electrically conductive fluid to resection unit **1406** and/or the target site of an ablation and resection procedure. The embodiment of FIG. **15B** may further include an aspiration device (see, for example, FIG. **15A**). In the embodiment of FIG. **15B**, tube **1434** is coupled to probe **1400** at handle **1404**, however other arrangements for coupling tube **1434** to probe **1400** are also within the scope of the invention.

[0154] FIGS. **16A-F** each show a resection unit **1406a-f** as seen in plan view, wherein each resection unit **1406a-f** includes a resection electrode support **1408** and at least one resection electrode head **1412**, according to various embodiments of the invention. Each resection electrode **1410** (e.g., FIG. **13**), may have a single terminal or resection electrode head **1412**, such that each resection electrode head **1412** is independently coupled to a power supply (e.g., power supply **428** of FIG. **2**). Alternatively, each resection electrode **1410** may have a plurality of terminals or resection electrode heads **1412**. Each resection electrode **1410** may be coupled to a power supply unit (not shown in FIGS. **16A-F**) via a connec-

tion block and connector cable, essentially as described hereinabove (e.g., with reference to FIGS. **2** & **4**).

[0155] FIG. **16A** indicates the longitudinal axis **1406'** of resection units **1406a-f**, as well as electrode support distal end **1408a** (indication of longitudinal axis **1406'** and support distal end **1408a** are omitted from FIGS. **16A-F** for the sake of clarity, however the orientation of resection units **1406b-f** is the same as that of resection unit **1406a**). In each of FIGS. **16A-F**, resection electrode heads **1412** are depicted as having an elongated, substantially rectangular shape in plan view. However, other shapes and arrangements for resection electrode heads **1412** are also within the scope of the invention.

[0156] FIGS. **16A-F** show just some of the arrangements of resection electrode head(s) **1412** on each resection electrode support **1408**, according to various embodiments. Briefly, FIG. **16A** shows a single resection electrode head **1412** located substantially centrally within support **1408** and aligned approximately perpendicular to longitudinal axis **1406'**. FIG. **16B** shows a plurality of resection electrode heads **1412** arranged substantially parallel to each other and aligned substantially perpendicular to axis **1406'**. FIG. **16C** shows a plurality of resection electrode heads **1412** arranged substantially parallel to each other and aligned substantially perpendicular to axis **1406'**, and an additional resection electrode head **1412** arranged substantially parallel to axis **1406'**. FIG. **16D** shows a plurality of resection electrode heads **1412** arranged substantially parallel to each other and aligned at an angle intermediate between parallel to axis **1406'** and perpendicular to axis **1406'**. FIG. **16E** shows a plurality of resection electrode heads **1412** including a first substantially parallel array **1412a** aligned at a first angle with respect to axis **1406'** and a second substantially parallel array **1412b** aligned at a second angle with respect to axis **1406'**. FIG. **16F** shows a plurality of resection electrode heads **1412** having an arrangement similar to that described for FIG. **16E**, wherein resection electrode heads **1412** are of different sizes.

[0157] FIG. **17** illustrates an angle at which a resection electrode head **1412** may be arranged on electrode support **1408** with respect to the longitudinal axis **1406'** of resection unit **1406**. According to certain embodiments, resection electrode heads **1412** may be arranged on electrode support **1408** at an angle in the range of from 0° to about 175° with respect to longitudinal axis **1406'**. In embodiments having first and second parallel arrays of resection electrode heads **1412**, e.g., FIG. **16E**, first array **1412a** is preferably arranged at an angle α in the range of from about 90° to 170° , and more preferably from about 105° to 165° . Second array **1412b** is preferably arranged at an angle β in the range of from about 10° to 90° , and more preferably from about 15° to 75° .

[0158] FIG. **18A** shows in plan view a resection electrode support **1408** arranged on shaft distal end portion **1402a**, wherein electrode support **1408** includes resection electrode head **1412**. FIGS. **18B-D** each show a profile of a resection electrode head **1412** on an electrode support **1408** as seen along the line **18B-D** of FIG. **18A**. From an examination of FIGS. **18B-D** it can be readily seen that, according to certain embodiments of the invention, resection electrode head **1412** may protrude a significant distance from the external surface of shaft **1402**. Typically, each resection electrode head **1412** protrudes from resection electrode support **1408** by a distance in the range of from about 0.1 to 20 mm, and preferably by a distance in the range of from about 0.2 to 10 mm. Resection electrode head **1412** may have a profile which is substantially square or rectangular; arched or semi-circular; or angular and

pointed, as represented by FIGS. 18B-D, respectively. Other profiles and shapes for resection electrode head 1412 are also within the scope of the invention. Only one resection electrode head 1412 is depicted per electrode support 1408 in FIGS. 18A-D. However, according to the invention, each electrode support 1408 may have a plurality of resection electrode heads 1412 arranged thereon in a variety of arrangements (see, e.g., FIGS. 16A-F).

[0159] In the embodiments of FIGS. 18B-D, each electrode head 1412 is in the form of a filament or wire of electrically conductive material. In one embodiment, the filament or wire comprises a metal. Such a metal is preferably a durable, corrosion resistant metal. Suitable metals for construction of resection electrode head 1412 include, without limitation, tungsten, stainless steel alloys, platinum or its alloys, titanium or its alloys, molybdenum or its alloys, and nickel or its alloys. In embodiments wherein each electrode head 1412 is in the form of a filament or wire, the diameter of the wire is preferably in the range of from about 0.05 mm to about 5 mm, more preferably in the range of from about 0.1 to about 2 mm.

[0160] FIGS. 19A-I each show a cross-section of the filament or wire of resection electrode head 1412 as seen, for example, along the lines 19A-I of FIG. 18B. Evidently, a variety of different cross-sectional shapes for resection electrode head 1412 are possible. For example, resection electrode head 1412 may be substantially round or circular, substantially square, or substantially triangular in cross-section, as depicted in FIGS. 19A-C, respectively. Resection electrode head 1412 may have a cross-section having at least one curved side. For example, head 1412d of FIG. 19D has two substantially parallel sides and two concave sides. Head 1412e of FIG. 19E has four concave sides forming four cusps, while head 1412f (FIG. 19F) includes three concave sides forming three cusps. FIGS. 19G-I each depict a cross-section of a wire or filament having serrations on at least one side thereof. Resection electrode head 1412g comprises a filament having a substantially circular cross-section, wherein the circumference of the filament is serrated. In another embodiment (not shown) a selected portion of the circumference of a substantially round filament may be serrated. Resection electrode head 1412h (FIG. 19H) comprises a filament having a substantially square cross-section, wherein a leading or cutting edge portion 1413h of the filament is serrated. FIG. 19I shows a head 1412i comprising a filament of an electrically conductive material having a substantially crescent-shaped or semi-circular cross-sectional shape, wherein cutting edge portion 1413i is serrated. In addition, other cross-sectional shapes for electrode head 1412 are contemplated and are within the scope of the invention. Preferably, the cross-sectional shape and other features of resection electrode head 1412 promote high current densities in the vicinity of resection electrode head 1412 following application of a high frequency voltage to resection electrode head 1412. More preferably, the cross-sectional shape and other features of resection electrode head 1412 promote high current densities in the vicinity of a leading or cutting edge, e.g., edge 1413h, 1413i, of resection electrode head 1412 following application of a high frequency voltage to resection electrode head 1412. As noted previously, high current densities promote generation of a plasma in the presence of an electrically conductive fluid, and the plasma in turn efficiently ablates tissue via the Coblation® procedure or mechanism. Preferably, the cross-sectional shape and other features of resection electrode head 1412 are also adapted for maintenance of the plasma in the

presence of a stream of fluid passing over resection electrode head 1412. In one embodiment, the cross-sectional shape and other features of resection electrode head 1412 are also adapted for the efficient mechanical resection, abrading, or severing of, at least, soft tissue (such as skeletal muscle, skin, cartilage, etc.).

[0161] In one embodiment a cutting edge, e.g., edge 1413h, 1413i, is adapted for both ablating and resecting tissue. Depending on the embodiment, cutting edge 1413h, 1413i may be oriented, or point, in various directions relative to the longitudinal axis of shaft 1402. For example, depending on the particular embodiment of probe 1400, and on the particular surgical procedure(s) for which embodiments of probe 1400 are designed to perform, cutting edge 1413h, 1413i may be oriented distally, proximally, or laterally.

[0162] Referring now to FIG. 20, a surgical kit 1500 for resecting and/or ablating tissue according to the invention will now be described. FIG. 20 schematically represents surgical kit 1500 including electrosurgical probe 1400, a package 1502 for housing probe 1400, a surgical instrument 1504, and an instructions for use 1506. Instructions for use 1506 include instructions for using probe 1400 in conjunction with apparatus ancillary to probe 1400, such as power supply 428 (FIG. 2). Package 1502 may comprise any suitable package, such as a box, carton, etc. In an exemplary embodiment, package 1502 includes a sterile wrap or wrapping 1504 for maintaining probe 1400 under aseptic conditions prior to performing a surgical procedure.

[0163] An electrosurgical probe 1400 of kit 1500 may comprise any of the embodiments described hereinabove. For example, probe 1400 of kit 1500 may include shaft 1402 having at least one resection electrode 1410 at shaft distal end 1402a, and at least one connector (not shown) extending from the at least one resection electrode 1410 to shaft proximal end 1402b for coupling resection electrode 1410 to a power supply. Probe 1400 and kit 1500 are disposable after a single procedure. Probe 1400 may or may not include a return electrode 1420.

[0164] Instructions for use 1506 generally includes, without limitation, instructions for performing the steps of: adjusting a voltage level of a high frequency power supply to effect resection and/or ablation of tissue at the target site; connecting probe 1400 to the high frequency power supply; positioning shaft distal end 1402a within an electrically conductive fluid at or near the tissue at the target site; and activating the power supply to effect resection and/or ablation of the tissue at the target site. An appropriate voltage level of the power supply is usually in the range of from about 40 to 400 volts RMS for operating frequencies of about 100 to 200 kHz. Instructions 1506 may further include instruction for advancing shaft 1402 towards the tissue at the target site, and for moving shaft distal end portion 1402a in relation to the tissue. Such movement may be performed with or without the exertion of a certain mechanical force on the target tissue via resection unit 1406, depending on parameters such as the nature of the procedure to be performed, the type of tissue at the target site, the rate at which the tissue is to be removed, and the particular design or embodiment of probe 1400/resection unit 1406.

[0165] FIGS. 21A-B schematically represent a method of performing a resection and ablation electrosurgical procedure, according to another embodiment of the invention, wherein step 1600 (FIG. 421A) involves providing an electrosurgical probe having a resection unit. The probe provided

in step **1600** includes a shaft distal end, wherein the resection unit is disposed at the shaft distal end, either laterally or terminally. The resection unit includes an electrode support comprising an insulating material and at least one resection electrode head arranged on the electrode support. Step **1602** involves adjusting a voltage level of a power supply, wherein the power supply is capable of providing a high frequency voltage of a selected voltage level and frequency. The voltage selected is typically between about 5 kHz and 20 MHz, essentially as described hereinabove. The RMS voltage will usually be in the range of from about 5 volts to 1000 volts, and the peak-to-peak voltage will be in the range of from about 10 to 2000 volts, again as described hereinabove. The actual or preferred voltage will depend on a number of factors, including the number and size of resection electrodes comprising the resection unit.

[**0166**] Step **1604** involves coupling the probe to the power supply unit. Step **1606** involves advancing the resection unit towards tissue at a target site whence tissue is to be removed. In optional step **1608**, a quantity of an electrically conductive fluid may be applied to the resection unit and/or to the target site. For performance of a resection and ablation procedure in a dry field, optional step **1608** is typically included in the procedure. Step **1608** may involve the application of a quantity of an electrically conductive fluid, such as isotonic saline, to the target site. The quantity of an electrically conductive fluid may be controlled by the operator of the probe. The quantity of an electrically conductive fluid applied in step **1608** may be sufficient to completely immerse the resection unit and/or to completely immerse the tissue at the target site. Step **1610** involves applying a high frequency voltage to the resection unit via the power supply unit. Step **1612** involves contacting the tissue at the target site with the resection unit.

[**0167**] With reference to FIG. **21B**, optional step **1614** involves exerting pressure on the tissue at the target site by applying a force to the probe, while the resection unit is in contact with the tissue at the target site, in order to effect resection of tissue. Typically, such a force is applied manually by the operator (surgeon), although mechanical application of a force to the probe, e.g., by a robotic arm under computer control, is also possible. The amount of any force applied in optional step **1614** will depend on factors such as the nature of the tissue to be removed, the design or embodiment of the probe, and the amount of tissue to be resected. For example, in the absence of any mechanical force applied to the tissue, tissue removal from the target site is primarily or solely by ablation. On the other hand, with the electrical power turned off, either transiently or for all or a portion of a procedure, the probe may be used for mechanical resection of tissue. Typically, however, the probe is used for the concurrent electrical ablation and mechanical resection of tissue.

[**0168**] Step **1616** involves moving the resection unit of the probe with respect to the tissue at the target site. Typically, step **1616** involves moving the resection unit and the at least one resection electrode head in a direction substantially perpendicular to a direction of any pressure exerted in step **1614**, or in a direction substantially parallel to a surface of the tissue at the target site. Typically, step **1616** is performed concurrently with one or more of steps **1608** through **1614**. In one embodiment, step **1616** involves repeatedly moving the resection unit with respect to the tissue at the target site until an appropriate quantity of tissue has been removed from the target site. Typically, a portion of the tissue removed from the target site is in the form of resected tissue fragments. Step

1618 involves aspirating the resected tissue fragments from the target site via at least one aspiration port on the shaft, wherein the at least one aspiration port is coupled to an aspiration lumen. In one embodiment, the probe includes at least one digestion electrode capable of aggressively ablating resected tissue fragments. Step **1620** involves ablating resected tissue fragments with the at least one digestion electrode. In one embodiment, the at least one digestion electrode is arranged within the aspiration lumen, and the resected tissue fragments are ablated within the aspiration lumen.

[**0169**] FIG. **22** schematically represents a method of making a resection and ablation electrosurgical probe, according to the invention, wherein step **1700** involves providing a shaft having a resection unit. The shaft provided in step **1700** includes a shaft proximal end and a shaft distal end, wherein the resection unit is disposed at the shaft distal end, either laterally or terminally. In one embodiment, the shaft comprises an electrically conductive lightweight metal cylinder. The resection unit includes an electrode support comprising an insulating material and at least one resection electrode arranged on the electrode support. Each resection electrode includes a resection electrode head. Each resection electrode head typically comprises a wire, filament, or blade of a hard or rigid, electrically conductive solid material, such as tungsten, stainless steel alloys, platinum or its alloys, titanium or its alloys, molybdenum or its alloys, nickel or its alloys, and the like.

[**0170**] Typically, the shaft provided in step **1700** further includes at least one digestion electrode capable of aggressively ablating tissue fragments. In one embodiment, the at least one digestion electrode is arranged within the aspiration lumen. Each digestion electrode typically comprises an electrically conductive metal, such as tungsten, stainless steel alloys, platinum or its alloys, titanium or its alloys, molybdenum or its alloys, nickel or its alloys, aluminum, gold, or copper, and the like. Typically, the shaft provided in step **1700** further includes a return electrode.

[**0171**] In one embodiment, the method includes step **1702** which involves encasing a portion of the shaft within an insulating sleeve to provide an electrically insulated proximal portion of the shaft and an exposed distal portion of the shaft. The exposed distal portion of the shaft defines a return electrode of the probe. The insulating sleeve typically comprises a substantially cylindrical length of a flexible insulating material such as polytetrafluoroethylene, a polyimide, and the like. Such flexible insulating materials are well known in the art. In one embodiment, the resection electrode support is disposed on the return electrode. The resection electrode support typically comprises an electrically insulating material such as a glass, a ceramic, a silicone, a polyurethane, a urethane, a polyimide, silicon nitride, teflon, alumina, or the like. The electrode support serves to electrically insulate the at least one resection electrode head from the return electrode. Step **1704** involves providing a handle having a connection block. Step **1706** involves coupling the resection electrodes and the digestion electrodes to the connection block. The connection block provides a convenient mechanism by which the resection and digestion electrodes may be coupled to a high frequency power supply. Step **1708** involves affixing the shaft proximal end to the handle.

[**0172**] FIGS. **23A** and **23B** show a side view and an end-view, respectively, of an electrosurgical suction apparatus **2100**, according to another embodiment of the invention. Apparatus **2100** generally includes a shaft **2102** having a shaft

distal end portion **2102a** and a shaft proximal end portion **2102b**, the latter affixed to a handle **2104**. An aspiration tube **2144**, adapted for coupling apparatus **2100** to a vacuum source, is joined at handle **2104**. An electrically insulating electrode support **2108** is disposed on shaft distal end portion **2102a**. Electrode support **2108** may comprise a durable or refractory material such as a ceramic, a glass, a fluoropolymer, or a silicone rubber. In one embodiment, electrode support **2108** comprises an alumina ceramic. A plurality of active electrodes **2110** are arranged on electrode support **2108**.

[0173] Shaft **2102** may comprise an electrically conducting material, such as stainless steel alloys, tungsten, platinum or its alloys, titanium or its alloys, molybdenum or its alloys, and nickel or its alloys. An insulating sleeve **2118** covers a portion of shaft **2102**. An exposed portion of shaft **2102** located between sleeve distal end **2118a** and electrode support **2108** defines a return electrode **2116**. In an alternative embodiment (not shown), shaft **2102** may comprise an insulating material and a return electrode may be provided on the shaft, for example, in the form of an annulus of an electrically conductive material.

[0174] FIG. 23B shows an end-view of apparatus **2100**, taken along the lines 23B-23B of FIG. 23A. A plurality of active electrodes **2110** are arranged substantially parallel to each other on electrode support **2108**. A void within electrode support **2108** defines an aspiration port **2140**. Typically, the plurality of active electrodes **2110** span or traverse aspiration port **2140**, wherein the latter is substantially centrally located within electrode support **2108**. Aspiration port **2140** is in communication with an aspiration channel **2142** (FIG. 23C) for aspirating unwanted materials from a surgical site.

[0175] FIG. 23C shows a longitudinal cross-section of the apparatus of FIG. 23A. Aspiration channel **2142** is in communication at its proximal end with aspiration tube **2144**. Aspiration port **2140**, aspiration channel **2142**, and aspiration tube **2144** provide a convenient aspiration unit or element for removing unwanted materials, e.g., ablation by-products, excess saline, from the surgical field during a procedure. The direction of flow of an aspiration stream during use of apparatus **2100** is indicated by the solid arrows. Handle **2104** houses a connection block **2105** adapted for independently coupling active electrodes **2110** and return electrode **2116** to a high frequency power supply (e.g., FIG. 1). An active electrode lead **2121** couples each active electrode **2110** to connection block **2105**. Return electrode **2116** is independently coupled to connection block **2105** via a return electrode connector (not shown). Connection block **2105** thus provides a convenient mechanism for independently coupling active electrodes **2110** and return electrode **2116** to a power supply (e.g., power supply **28**, FIG. 1).

[0176] FIG. 24A is a longitudinal cross-section of the shaft distal end **2102a** of an electrosurgical suction apparatus **2100**, showing the arrangement of active electrode **2110** according to one embodiment. Active electrode **2110** includes a loop portion **2113**, a free end **2114**, and a connected end **2115**. Active electrode **2110** is disposed on electrode support **2108**, and is in communication at connected end **2115** with active electrode lead **2121** for coupling active electrode **2110** to connection block **2105**. Aspiration channel **2142** is omitted from FIG. 24A for the sake of clarity. FIG. 24B is a cross-section of active electrode **2110** as taken along the lines 24B-24B of FIG. 24A, showing an electrode distal face **2111**. Although FIG. 24B shows a substantially rectangular shape

for active electrode **2110**, other shapes (e.g., those depicted in FIGS. 19A-I) are also possible under the invention.

[0177] FIG. 24C shows in more detail active electrode **2110** in the form of a loop of flattened wire in communication with electrode lead **2121**, according to one embodiment of the invention. Typically, free end **2114** terminates within electrode support **2108** or within another electrically insulating material. In this embodiment, electrode lead **2121** is integral with active electrode **2110**. Electrode lead **2121** and active electrode **2110** may each comprise a highly conductive, corrosion-resistant metal such as tungsten, stainless steel alloys, platinum or its alloys, titanium or its alloys, molybdenum or its alloys, nickel or its alloys, iridium, aluminum, gold, copper, and the like. In one embodiment, one or both of electrode lead **2121** and active electrode **2110** may each comprise a platinum/iridium alloy, such as an alloy comprising from about 85% to 95% platinum and from about 5% to 15% iridium.

[0178] FIG. 25A shows an electrosurgical suction apparatus **2100** having an outer sheath **2152** external to shaft **2102** to provide an annular fluid delivery channel **2150**, according to another aspect of the invention. The distal terminus of outer sheath **2152** defines an annular fluid delivery port **2156** at a location proximal to return electrode **2116**. Outer sheath **2152** is in communication at its proximal end with a fluid delivery tube **2154** at handle **2104**. Fluid delivery port **2156**, fluid delivery channel **2150**, and tube **2154** provide a convenient fluid delivery unit for providing an electrically conductive fluid (e.g., isotonic saline) to the distal end of the suction apparatus or to a target site undergoing treatment. The direction of flow of an electrically conductive fluid during use of apparatus **2100** is indicated by the solid arrows. An extraneous electrically conductive fluid forms a current flow path between active electrodes **2110** and return electrode **2116**, and can facilitate generation of a plasma in the vicinity of active electrodes **2110**, as described hereinabove. Provision of an extraneous electrically conductive fluid may be particularly valuable in a dry field situation (e.g., in situations where there is a paucity of native electrically conductive bodily fluids, such as blood, synovial fluid, etc.). In an alternative embodiment, an electrically conductive fluid, such as saline, may be delivered to the distal end of suction apparatus **2100** by a separate device (not shown). FIG. 25B is a transverse cross-section of shaft **2102** of the apparatus of FIG. 25A, and shows the relationship between outer sheath **2152**, shaft **2102**, and fluid delivery port **2156**. Aspiration channel **2142** and electrode lead **2121** are omitted from FIGS. 25A, 25B for the sake of clarity.

[0179] With reference to FIG. 26A there is shown in longitudinal cross-section the shaft distal end **2102a** of an electrosurgical suction apparatus **2100** including a baffle or trap **2146**, according to another embodiment, wherein baffle **2146** is arranged transversely within shaft **2102** at the distal end of aspiration channel **2142**. In the embodiment shown, baffle **2146** is recessed with respect to treatment surface **2109** to define a holding chamber **2148** within the void of electrode support **2108**. As seen in the end view of FIG. 26B, baffle **2146** includes a plurality of aspiration ports **2140'**. The size, number, and arrangement of ports **2140'** on baffle **2146** is at least to some extent a matter of design choice. A plurality of active electrodes **2110** are arranged substantially parallel to each other on electrode support **2108**. During a procedure involving resection or ablation of tissue, any relatively large resected tissue fragments or other tissue debris drawn by

suction to a location proximal to active electrodes **2110** may be retained by baffle **2146** within holding chamber **2148**. By relatively large resected tissue fragments is meant those fragments too large to be readily drawn through ports **2140'** in an aspiration stream. Such tissue fragments temporarily retained by baffle **2146** are conveniently positioned with respect to active electrodes **2110**, and are readily digested by one or more of active electrodes **2110** by a suitable high frequency voltage applied between active electrodes **2110** and return electrode **2116**. As an additional advantage, because aspiration channel **2142** is wider than each of aspiration ports **2140'**, the former is not subject to being clogged by resected tissue fragments or other debris. Using the configuration of FIGS. **26A**, **26B** only aspiration ports **2140'** are subject to (temporary) blockage; as pointed out above, any tissue fragments too large to pass through ports **2140'** are rapidly digested by active electrodes **2110**. Baffle **2146** may be constructed from an electrically insulating material, such as various plastics. Alternatively, baffle **2146** may comprise an electrically conducting material such as various metals, in which case baffle **2146** is typically electrically isolated.

[0180] FIG. **27A** is a longitudinal cross-section of a shaft distal end **2102a** of a suction apparatus **2100**, according to another embodiment, wherein shaft distal end **2102a** is curved. The distal end of electrode support **2108** defines a treatment surface **2109** (the latter perhaps best seen in FIG. **28A**). A curve in shaft distal end **2102a** may facilitate access of treatment surface **2109** to a site targeted for electrosurgical treatment. Active electrodes **2110**, which typically protrude from treatment surface **2109** (e.g., FIGS. **28A**, **28B**), are omitted from FIG. **27A** for the sake of clarity.

[0181] FIG. **27B** is a longitudinal cross-section of shaft distal end **2102a** of a suction apparatus **2100**, according to another embodiment of the invention, wherein the distal end of electrode support **2108** is beveled at an angle, α . Typically angle α is in the range of from about 15° to 60°, more typically from about 20° to 45°, and usually from about 25° to 35°. Active electrodes **2110** are omitted from FIG. **27B** for the sake of clarity. A beveled treatment surface **2109** may facilitate access of shaft distal end portion **2102a** to tissue at a target site as well as manipulation of shaft **2102** during treatment.

[0182] FIG. **28A** shows a specific configuration of a shaft distal end **2102a** of an electrosurgical suction apparatus **2100**, according to one embodiment of the invention. The distal end of electrode support **2108** defines a beveled treatment surface **2109**. A first, a second, and a third active electrode **2110a, b, c** extend from treatment surface **2109**. Treatment surface **2109** includes a rounded perimeter **2107** which serves to eliminate sharp edges from electrode support **2108**. The presence of rounded perimeter **2107** prevents mechanical damage to delicate or sensitive tissues during use of apparatus **2100**. Electrode support **2108** encircles aspiration port **2140**.

[0183] Loop portions **2113** (e.g., FIG. **24C**) of first, second, and third active electrodes, **2110a**, **2110b**, **2110c**, traverse or bridge aspiration port **2140**. First, second, and third active electrodes, **2110a**, **2110b**; **2110c** are arranged substantially parallel to each other, and protrude from treatment surface **2109**. In the case of second active electrode **2110b**, the orientation with respect to treatment surface **2109** of free end **2114**, loop portion **2113**, and connected end **2115** is at least substantially the same. In contrast, in the case of first and third active electrodes **2110a**, **2110c**, the orientation with respect to treatment surface **2109** of loop portion **2113** is different from

the orientation of connected end **2115** and free end **2114**. That is to say, the orientation of active electrodes **2110a** and **2110c** with respect to treatment surface **2109** changes from a first direction in the region of connected end **2115** and free end **2114**, to a second direction in the region of loop portion **2113**.

[0184] Furthermore, loop portions **2113** of first, second, and third active electrodes, **2110a**, **2110b**, **2110c** are oriented in different directions. Thus, second electrode **2110b** extends substantially in the direction of the longitudinal axis of shaft **2102**, and distal face **2111b** is also oriented in the direction of the longitudinal axis of shaft **2102**. First and third electrodes **2110a**, **2110c** flank second electrode **2110b**, loop portions **2113** of first and second electrodes **2110a**, **2110c** are oriented towards second electrode **2110b**, and distal faces **2111a**, **2111c** both face towards second electrode **2110b**. In other words, first, second, and third electrodes **2110a**, **2110b**, **2110c** all point in different directions.

[0185] Perhaps as best seen in FIG. **28B**, each active electrode **2110a-c** includes a distal face **2111a-c**. In the embodiment of FIGS. **28A**, **28B**, each distal face **2111a**, **2111b**, **2111c** faces, or is oriented in, a different direction as described with reference to FIG. **28A**. Furthermore, a dashed line L_p drawn parallel to treatment surface **2109** illustrates that the orthogonal distance, Do from treatment surface **2109** to each distal face **2111a, b, c** is substantially the same for each of active electrodes **2110a, b, c**.

[0186] Electrosurgical suction apparatus **2100** described with reference to FIGS. **23A** through **23B** can be used for the removal, resection, ablation, and contouring of tissue during a broad range of procedures, including procedures described hereinabove with reference to other apparatus and systems of the invention. Typically during such procedures, the apparatus is advanced towards the target tissue such that treatment surface **2109** and active electrodes **2110** are positioned so as to contact, or be in close proximity to, the target tissue. Each of the plurality of active electrodes includes a loop portion adapted for ablating tissue via molecular dissociation of tissue components upon application of a high frequency voltage to the apparatus. In one embodiment, an electrically conductive fluid may be delivered to the distal end of the apparatus via a fluid delivery channel to provide a convenient current flow path between the active and return electrodes. A high frequency voltage is applied to the apparatus from a high frequency power supply to ablate the tissue at the target site. Suitable values for various voltage parameters are presented hereinabove.

[0187] Unwanted materials, such as low molecular weight ablation by-products, excess extraneously supplied fluid, resected tissue fragments, blood, etc., are conveniently removed from the target site via the integral aspiration unit of the invention. Typically, such an aspiration unit comprises an aspiration channel in communication with a distal aspiration port and a proximal aspiration tube, the latter coupled to a suitable vacuum source (not shown). Vacuum sources suitable for use in conjunction with apparatus and systems of the invention are well known in the art.

[0188] In one embodiment, the apparatus may be reciprocated or otherwise manipulated during application of the high frequency voltage, such that loop portion **2113** including distal face **2111** of each active electrode moves with respect to the target tissue, and the tissue in the region of each distal face **2111** is ablated via molecular dissociation of tissue components. The apparatus is capable of effectively removing tissue

in a highly controlled manner, and is particularly useful in procedures requiring a smooth and/or contoured tissue surface.

[0189] FIG. 29 is a block diagram schematically representing an electrosurgical system 2200, according to one embodiment of the invention. System 2200 includes an electrosurgical instrument 2201, such as a probe or catheter, including a shaft 2202 and an electrode assembly 2220. System 2200 further includes a high frequency power supply 2228 coupled to electrode assembly 2220. Typically, instrument 2201 further includes an aspiration unit 2230 and a fluid delivery unit 2240 coupled, respectively, to a vacuum source 2250 and a fluid source 2260. Aspiration unit 2230 is adapted for aspirating excess or unwanted materials from a working end of instrument 2201 or from a surgical site during a procedure. Fluid delivery unit 2240 is adapted for delivering an electrically conductive fluid to the working end of instrument 2201, or to a surgical site, during certain procedures.

[0190] FIG. 30 is a block diagram schematically representing an electrosurgical instrument 2300, according to another aspect of the invention. Instrument 2300 includes an electrode assembly 2320 comprising an electrode array 2310. In one embodiment, electrode assembly 2320 is disposed on an electrically insulating electrode support 2308. Electrode array 2310 includes a plurality of active electrodes 2312. Each active electrode 2312 is adapted for at least one of the following functions: i) localized ablation of a target tissue, ii) localized coagulation of a target tissue, and iii) digestion of resected tissue fragments. In one embodiment, electrode support 2308 comprises a ceramic, a glass, or a silicone rubber. According to one aspect of the invention, the electrode support includes a tissue treatment surface, and the plurality of active electrodes are arranged substantially parallel to each other on the treatment surface (e.g., FIGS. 35 and 37). Other configurations for the electrode assembly are also within the scope of the invention. According to one aspect of the invention, the electrode support includes a recess within the tissue treatment surface (e.g., FIGS. 34C and 34E).

[0191] FIG. 31 is a block diagram schematically representing an active electrode 2412 for an electrosurgical instrument, according to another embodiment of the invention. Active electrode 2412 includes a first filament 2413a, a second filament 2413b, and a bridge portion 2414. Typically, bridge portion 2414 is suspended between first filament 2413a and second filament 2413b. According to one embodiment of the invention, the cross-sectional area of bridge portion 2414 is greater than that of either first filament 2413a or second filament 2413b. In one embodiment, the bridge portion includes a first distal face, and a second distal face contiguous with the first distal face to define a distal edge (e.g., FIGS. 34B-D). Typically, active electrode 2412 comprises a material such as stainless steel, molybdenum, platinum, tungsten, palladium, iridium, titanium, or their alloys.

[0192] FIG. 32 schematically represents an electrosurgical instrument or probe 2500 as seen in side view, according to another aspect of the invention. Electrosurgical instrument 2500 includes a shaft 2502, having a shaft distal end 2502a and a shaft proximal end 2502b, and a handle 2504 affixed to shaft proximal end 2502b. Shaft 2502 includes an inner shaft 2502' and an outer shaft 2502". A proximal portion of inner shaft 2502' is ensheathed within an electrically insulating sleeve or sheath 2503. In one embodiment, inner shaft 2502' comprises a metal tube, and an exposed distal portion of inner shaft 2502' defines a return electrode 2518. Inner shaft 2502'

may comprise stainless steel, or the like, while sheath 2503 may comprise a heat shrink tube. Outer shaft 2502" may comprise an electrically insulating material, such as various resin-based composite materials, which may include a fibrous component. In one embodiment, outer shaft 2502" comprises a Polygon Tube™ (Polygon Company, Walkerton, Ind.).

[0193] Again with reference to FIG. 32, an electrically insulating electrode support or spacer 2508 is disposed at shaft distal end 2502a. Typically, at least one active electrode is disposed on electrode support 2508. (Active electrodes are omitted from FIG. 32, e.g., for the sake of clarity.) An aspiration lumen 2534 is disposed within shaft 2502. A distal end of aspiration lumen 2534 is coupled to a void in electrode support 2508 (e.g., FIGS. 34E, 35). A proximal end of aspiration lumen 2534 is coupled to an aspiration tube 2536. Aspiration lumen 2534 is adapted for removing unwanted materials from the working end of instrument 2500 via an aspiration stream (represented in FIG. 32 by open arrows). As shown in FIG. 32, aspiration tube 2536 extends from handle 2504, although other configurations are possible under the invention. In one embodiment, the aspiration lumen may be accommodated within a multi-lumen tube (not shown), wherein the multi-lumen tube lies longitudinally within shaft 2502. In one embodiment, the multi-lumen tube is formed as a plastic extrusion product, the latter well known in the art. Aspiration tube 2536 is adapted for coupling to a suitable vacuum source. Such vacuum sources are well known to the skilled artisan.

[0194] FIG. 33A is a side view of the working or distal end 2600a of an electrosurgical instrument having a fluid delivery element, according to another aspect of the invention. A shaft 2602, e.g., comprising a metal tube, includes a plurality of external, longitudinal grooves 2635. An electrically insulating electrode support or spacer 2608 is disposed at a shaft distal end 2602a. Active electrodes (e.g., FIGS. 34A-D) are omitted from FIG. 33A for the sake of clarity. A portion of shaft 2602 is ensheathed within an electrically insulating sleeve or sheath 2603. A longitudinal void or fluid channel 2634 is defined jointly by each groove 2635 and an inner surface of sheath 2603. In one embodiment, grooves 2635 are restricted to a distal portion of the shaft. Each of the plurality of fluid channels 2634 may be coupled to a fluid source via a fluid delivery tube (e.g., FIGS. 15B, 25A), whereby an electrically conductive fluid, e.g., saline, may be delivered to working end 2600a in the vicinity of electrode support 2608. An exposed distal portion of shaft 2602 defines a return electrode 2618. Thus, grooves 2635 extend along return electrode 2618, whereby fluid may be delivered directly to return electrode 2618. In some embodiments, the distal end of the shaft may be curved (e.g., FIGS. 24A, 34B), and each groove may follow the contour or curve of the shaft.

[0195] FIG. 34B is a cross-sectional view taken along the lines 23B-23B of FIG. 33A showing sheath 2603 ensheathing shaft 2602, a plurality of external grooves 2635 on shaft 2602, and a corresponding plurality of fluid channels 2634 between shaft 2602 and an internal surface of sheath 2603. In one embodiment, sheath 2603 comprises a heat shrink tube. Although FIG. 33B shows six external grooves/fluid delivery channels 2635/2634, other numbers and arrangements are also within the scope of the invention.

[0196] FIG. 34A is a side view of an electrosurgical instrument 2700, according to one embodiment of the invention. Instrument 2700 includes a shaft 2702, having a shaft distal end 2702a and a shaft proximal end 2702b, and a handle 2704

at shaft proximal end 2702*b*. A distal portion of shaft 2702 is ensheathed within an electrically insulating sleeve or sheath 2703. In one embodiment, sheath 2703 may comprise a heat shrink tube. An exposed (non-insulated) portion of shaft distal end 2702*a* defines a return electrode. In one embodiment, return electrode 2718 comprises an exposed, or naked, length of a metal tube or cylinder. In the embodiment shown in FIG. 34A, shaft distal end 2702*a* is curved.

[0197] Again with reference to FIG. 34A, an electrically insulating electrode support 2708 is disposed at shaft distal end 2702*a*. At least one active electrode 2712 is disposed on electrode support 2708. FIG. 34A shows an electrode array 2710 comprising two active electrodes 2712. However, electrode arrays having other numbers of active electrodes are also within the scope of the invention. Handle 2704 houses a connection block 2706. Each active electrode 2712 and return electrode 2718 are coupled to connection block 2706 via one or more electrode leads or filaments (e.g., FIG. 23C). Connection block 2706 permits the facile connection of active electrodes 2712 and return electrode 2718 to a high frequency power supply (e.g., FIGS. 1, 29). In one embodiment, each active electrode is independently coupled to a separate channel of the high frequency power supply.

[0198] FIG. 34B is a side view of the working or distal end of instrument 2700 of FIG. 34A, showing active electrode 2712 protruding from electrode support 2708. Only a single active electrode is shown in FIG. 34B, for the sake of clarity. Thus, the numbers of active electrodes shown in the Drawings should not be construed as limiting the invention. Electrode support 2708 includes a treatment surface 2707 and a recess 2709 within treatment surface 2707.

[0199] FIG. 34C shows the working end of instrument 2700 as seen along the lines 34C-34C of FIG. 34B. Each active electrode 2712 includes first and second filaments 2713*a*, 2713*b* extending from treatment surface 2707 of support 2708, and a bridge portion 2714 between first filament 2713*a* and second filament 2713*b*. Bridge portion 2714 is coupled to connection block 2706 (FIG. 34A) via at least one of first filament 2713*a* and second filament 2713*b*. Bridge portion 2714 is spaced from treatment surface 2707 by a minimum distance typically in the range of from about 0.05 to 3 mm. More typically, bridge portion 2714 is spaced from treatment surface 2707 by a distance not less than from about 0.1 to 2 mm. Bridge portion 2714 spans recess 2709. A void within recess 2709 defines an aspiration port 2732. Aspiration port 2732 is in communication proximally within an aspiration lumen 2734 within shaft 2702.

[0200] FIG. 34D shows a distal portion of bridge portion 2714 of active electrode 2712 as seen along the lines 34D-34D of FIG. 34C. Thus, bridge portion 2714 includes a first distal face 2715*a* and a second distal face 2715*b* contiguous with first distal face 2715*a* to define a distal edge 2716, wherein distal edge 2716 is characterized by angle x . Typically, angle x is an acute angle in the range of from about 25° to 85°. In one embodiment, angle x is in the range of from about 30° to 65°. Each active electrode 2712 may have one or more other edges in addition to distal edge 2716. While not being bound by theory, applicant believes that the presence of edge(s) on the active electrode(s) generates relatively high current densities and promotes formation of a plasma in the vicinity of the active electrode(s) upon application of a high frequency voltage between the active electrode(s) and the return electrode.

[0201] FIG. 34E is a perspective view of the working end of instrument 2700 of FIG. 34A, showing the location of recess 2709 with respect to treatment surface 2707, as well as the location of aspiration port 2732 within recess 2709. In the embodiment shown in FIG. 34E, treatment surface 2707 is substantially planar, recess 2709 is substantially linear and bisects treatment surface 2707, while aspiration port 2732 is substantially centrally located within recess 2709. However, other configurations and locations for these elements are also within the scope of the invention. The active electrode(s) are omitted from FIG. 34E for the sake of clarity.

[0202] FIG. 35 is a face view of an electrode assembly 2820 of an electrosurgical instrument, illustrating the configuration of a plurality of active electrodes on an electrode support 2808, each active electrode including a bridge portion, 2814*a-n*. Electrode support 2808 includes a treatment surface 2807 and a recess 2809. Bridge portions 2814*a*, 2814*b*, 2814*n* are arranged substantially parallel to each other on treatment surface 2807. Each bridge portion 2814*a*, 2814*b*, 2814*n* spans recess 2809 and is arranged substantially orthogonal thereto. An aspiration port 2832 is located within recess 2809. In the embodiment shown in FIG. 35, bridge portion 2814*b* spans aspiration port 2832. Although FIG. 35 shows three parallel active electrodes, other numbers and configurations of active electrodes are also within the scope of the invention.

[0203] FIG. 36 is a side view of a working or distal end 2900*a* of an electrosurgical instrument, including a shaft distal end 2902*a* and an electrode support 2908 disposed at shaft distal end 2902*a*. Electrode support 2908 includes a treatment surface 2907 arranged at an angle, y with respect to the longitudinal axis, AX of the instrument. In one embodiment, angle y is in the range of from about 25° to 75°, and often from about 30° to 60°. An active electrode 2912 extends distally from electrode support 2908 at an angle, z with respect to treatment surface 2907. In one embodiment, angle z is in the range of from about 35° to 95°, and in some instances from about 60° to 85°. For the sake of clarity, a single active electrode 2912 is schematically represented in FIG. 36 as a rectangular shape. Instruments of the invention may feature active electrodes having various geometries, e.g., as described hereinabove.

[0204] FIG. 37 is a perspective view of an electrode assembly 3020 for an electrosurgical instrument, according to one embodiment of the invention. Electrode assembly 3020 includes first, second, and third active electrodes 3012, 3012', and 3012" arranged parallel to each other on a treatment surface 3007 of an electrode support 3008. As shown, treatment surface 3007 is substantially planar. First, second, and third active electrodes 3012, 3012', and 3012" each comprise a first filament 3013*a*, 3013*a'*, and 3013*a''*, respectively; a second filament 3013*b*, 3013*b'*, and 3013*b''*, respectively; and a bridge portion 3014, 3014', and 3014", respectively. In one embodiment, each bridge portion is arranged substantially orthogonal to both the first and second filaments, and each bridge portion is oriented in substantially the same direction. Bridge portions 3014, 3014', and 3014", have lengths represented as l_1 , l_2 , and l_3 , respectively. As shown in FIG. 37, l_1 is approximately the same as l_3 , while l_2 is greater than l_1 and l_3 . In one embodiment, the distance between the first and second filaments of an active electrode (e.g., electrode 3012) is less than the length of the corresponding bridge portion. Thus, the distance 11' between first and second filaments 3013*a*, 3013*b* is less than the length l_1 of bridge portion 3014. Typically, each pair of filaments, e.g., first and second filaments 3013*a*,

3013b, extend through a corresponding pair of electrode ports (not shown) located within support **3008**.

[0205] FIG. 38 schematically represents a series of steps involved in a method of treating a target tissue during a surgical procedure, according to another embodiment of the invention, wherein step **3100** involves providing an electro-surgical instrument or probe adapted for treating the target tissue. In one embodiment, an instrument provided in step **3100** is adapted for the controlled ablation of the target tissue, as well as spot coagulation of tissue, and the digestion of resected tissue fragments. Electrosurgical instruments of step **3100** may have certain elements, features, and characteristics of various embodiments of the invention described hereinabove. In one embodiment, an instrument provided in step **3100** includes a distal or working end, and an electrode assembly disposed at the working end, wherein the electrode assembly comprises at least one active electrode disposed on an electrically insulating electrode support. According to one aspect of the invention, an instrument of step **3100** is adapted for the controlled removal of soft tissue during laparoscopic procedures. In one embodiment, such an instrument is adapted for the controlled removal and/or coagulation of ectopic endometrial lesions or implants. In use, instruments of the invention are coupled to a high frequency power supply (e.g., FIG. 1) adapted for operation in the ablation mode or the sub-ablation mode. In one embodiment, the instrument has a curved working end (e.g., FIG. 34A).

[0206] Step **3102** involves advancing the working end of the instrument towards a target tissue. In one embodiment, the instrument is advanced towards the target tissue via a laparoscope. In one embodiment, the instrument is adapted for advancement through a 5 mm cannula. Step **3104** involves positioning the electrode assembly in at least close proximity to the target tissue, e.g., such that at least one active electrode is in contact with, or adjacent to, the target tissue. As an example, the target tissue may be an endometrial implant located on the bowel, the ovaries, the urinary bladder, or the ureter of a patient.

[0207] Step **3106** involves applying a high frequency voltage between the active electrode(s) and a return electrode, in either the ablation mode or the sub-ablation mode, such that the target tissue is ablated (e.g., via Coblation®), or coagulated (sub-ablation mode). The parameters of the applied voltage are typically within the ranges cited hereinabove, e.g., in the range of from about 200 volts RMS to 1000 volts RMS in the ablation mode, and in the range of from about 10 volts RMS to 150 volts RMS in the sub-ablation mode. In one embodiment, the return electrode is integral with the probe, and comprises a non-insulated portion of a metal tube located proximal to the active electrode(s). During and/or prior to step **3106**, an electrically conductive fluid, such as isotonic saline, may be delivered to the working end of the instrument, or to the target tissue, via a fluid delivery element integral with the instrument. Such fluid may provide a current flow path between the active electrode(s) and the return electrode.

[0208] Optional step **3108** involves manipulating the instrument such that the electrode assembly is translated with respect to the target tissue. In one embodiment, the electrode assembly is positioned according to step **3104**, and thereafter the instrument is manipulated such that the active electrode(s) repeatedly move over the target tissue in a smooth “brushing” motion, whereby target tissue is selectively removed with little or no collateral damage to underlying tissue. Removal of target tissue (e.g., abnormal tissue, such as neoplasms, or

ectopic endometrial tissue) according to the invention may result in the formation of gaseous by-products and, in some instances, resected fragments of target tissue. It is generally advantageous to remove such ablation by-products and resected tissue fragments from the surgical site. To this end, the instrument is typically adapted for aspirating unwanted or excess materials, including gaseous ablation by-products, from the surgical site. Step **3110** involves aspirating such unwanted or excess materials from the surgical site, or from the working end of the instrument; via an aspiration unit which may be integral with the instrument. In some embodiments, the active electrode(s) are adapted for digesting tissue fragments to form smaller fragments and/or gaseous ablation by-products, thereby preventing blockage of the aspiration unit by larger tissue fragments.

[0209] Instruments of the invention may be used during a broad range of laparoscopic procedures, including the removal or coagulation of endometrial tissue from the bowel, ovaries, ureter, urinary bladder, or other sites of the abdominal cavity, including ablation of endometriomas, as well as appendectomies, and the removal of fibroid tumors, and the like.

[0210] Other modifications and variations can be made to the disclosed embodiments without departing from the subject invention. For example, other numbers and arrangements of the active electrodes on the electrode support are possible, under the invention. In addition, certain elements or features of various disclosed embodiments may be substituted for corresponding or analogous elements or features of other disclosed embodiments, or may be combined with elements and features of other disclosed embodiments, as will be apparent to the skilled artisan. Therefore, while certain embodiments of the present invention have been described in detail, by way of example and for clarity of understanding, a variety of changes, adaptations, and modifications will be obvious to those of skill in the art. Therefore, the scope of the present invention is limited solely by the appended claims.

What is claimed is:

1. An electrosurgical apparatus for treating tissue at a target site, comprising:
 - a shaft having a shaft distal end and a shaft proximal end;
 - an electrically insulating electrode support disposed at the shaft distal end; and
 - a plurality of active electrodes arranged substantially parallel to each other on the electrode support, wherein the shaft comprises an inner shaft and an outer shaft, wherein a proximal portion of the inner shaft lies within the outer shaft, and a distal portion of the inner shaft extends distally from the outer shaft.
2. The apparatus of claim 1, wherein the inner shaft comprises a metal tube.
3. The apparatus of claim 2, wherein the metal tube comprises stainless steel.
4. The apparatus of claim 2, wherein the metal tube has a curved distal end.
5. The apparatus of claim 1, wherein the outer shaft comprises an electrically insulating tube.
6. The apparatus of claim 5, wherein the outer shaft comprises a composite material, the composite material including a resin.
7. The apparatus of claim 6, wherein the composite material further includes a fibrous material.

8. The apparatus of claim 1, further comprising an electrically insulating sleeve ensheathing a length of the inner shaft, wherein the inner shaft includes at least one longitudinal, external groove.

9. The apparatus of claim 1, further comprising a return electrode.

10. The apparatus of claim 9, wherein the return electrode comprises an exposed, distal portion of the inner shaft.

11. The apparatus of claim 1, further comprising a fluid delivery unit.

12. The apparatus of claim 11, wherein the fluid delivery unit comprises a plurality of fluid delivery channels, each fluid delivery channel defined jointly by an external groove in the inner shaft and an inner surface of an electrically insulating sleeve, the sleeve ensheathing a length of the inner shaft.

13. The apparatus of claim 1, wherein each of the plurality of active electrodes comprises a first filament, a second filament, and a bridge portion suspended between the first filament and the second filament.

14. The apparatus of claim 1, wherein each of the plurality of active electrodes including a distal edge, wherein the distal edge is characterized by an acute angle in the range of from about 25° to 85°.

15. The apparatus of claim 13, wherein the electrode support includes a substantially planar treatment surface, and wherein each bridge portion is spaced from the treatment surface by a minimum distance in the range of from about 0.05 mm to 3 mm.

16. The apparatus of claim 13, wherein the electrode support includes a treatment surface and a recess within the treatment surface, and each bridge portion spans the recess.

17. The apparatus of claim 16, wherein the treatment surface is bisected by the recess.

18. The apparatus of claim 1, wherein the electrode support comprises a ceramic.

19. The apparatus of claim 16, further comprising an aspiration unit adapted for aspirating excess or unwanted materials from a working end of the apparatus or from a surgical site.

20. The apparatus of claim 19, wherein the aspiration unit includes an aspiration port, and wherein the aspiration port lies within the recess.

21. The apparatus of claim 1, further comprising a connection block adapted for coupling the plurality of active electrodes to a high frequency power supply, wherein each of the plurality of active electrodes comprises a bridge portion, a first filament, and a second filament, and wherein at least one of the first filament and the second filament is coupled to the connection block.

22. An electrosurgical instrument, comprising:

a shaft having a shaft distal end, the shaft distal end having a plurality of longitudinal, external grooves;
an electrode assembly disposed at the shaft distal end; and
an electrically insulating sheath external to the shaft distal end, the sheath and the plurality of grooves jointly defin-

ing a corresponding plurality of fluid delivery channels external to the shaft distal end, each of the plurality of fluid delivery channels adapted as a fluid conduit.

23. The instrument of claim 22, wherein the electrically insulating sheath comprises a heat shrink tube.

24. The instrument of claim 22, wherein the electrode assembly comprises an electrically insulating electrode support having a treatment surface, and at least one active electrode disposed on the treatment surface.

25. The instrument of claim 24, wherein each active electrode includes a distal edge, each distal edge characterized as having an acute angle.

26. The instrument of claim 22, wherein the shaft distal end is curved.

27. A method of electrosurgically removing ectopic endometrial tissue of a patient, the method comprising:

- a) providing an electrosurgical probe, the probe including an electrode assembly having at least one active electrode;
- b) positioning the electrode assembly in at least close proximity to a target endometrial implant; and
- c) applying a high frequency voltage between a return electrode and the at least one active electrode, wherein the voltage is effective in removing the endometrial implant with little or no damage to tissue underlying the endometrial implant.

28. The method of claim 27, wherein the electrode assembly includes a plurality of active electrodes, and wherein said step b) comprises positioning at least one of the plurality of active electrodes in at least close proximity to the endometrial implant.

29. The method of claim 27, wherein said step b) comprises advancing a working end of the probe towards the endometrial implant via a laparoscope.

30. The method of claim 27, wherein said step b) comprises advancing a working end of the probe towards the bowel, the ureter, the urinary bladder, or the ovaries of the patient.

31. The method of claim 28, wherein each of the plurality of active electrodes includes a bridge portion, the electrode assembly configured such that each of the bridge portions are substantially parallel to each other, and wherein the electrode assembly is adapted for the removal of soft tissue in a controlled manner.

32. The method of claim 27, wherein the voltage applied in said step c) is effective in vaporizing the endometrial implant to form gaseous ablation by-products.

33. The method of claim 32, wherein the probe provided in said step a) includes an integral aspiration unit, and the method further comprises:

- d) aspirating the gaseous ablation by-products from the vicinity of the target endometrial implant via the aspiration unit.

* * * * *

专利名称(译)	用于腹腔镜检查的电外科设备和方法		
公开(公告)号	US20080132890A1	公开(公告)日	2008-06-05
申请号	US12/031771	申请日	2008-02-15
[标]申请(专利权)人(译)	亚瑟罗凯尔公司		
申请(专利权)人(译)	ARTHROCARE CORPORATION		
当前申请(专利权)人(译)	ARTHROCARE CORPORATION		
[标]发明人	WOLOSZKO JEAN ELLSBERRY MARIA B		
发明人	WOLOSZKO, JEAN ELLSBERRY, MARIA B.		
IPC分类号	A61B18/14 A61B		
CPC分类号	A61B18/1402 A61B18/148 A61B18/1482 A61B18/1485 A61B2018/00577 A61B2018/00583 A61B2218/007 A61B2018/1213 A61B2018/1407 A61B2018/144 A61B2018/1467 A61B2018/1472 A61B2218/002 A61B2018/00601		
优先权	08/446767 1995-06-02 US PCT/US1994/005168 1994-05-10 WO 60/233345 2000-09-18 US 60/210567 2000-06-09 US		
其他公开文献	US7824405		
外部链接	Espacenet USPTO		

摘要(译)

用于治疗患者目标部位处的组织的电外科方法和设备。一种电外科器械，包括：轴，具有轴远端和轴近端；以及电极组件，设置在轴远端。电极组件包括设置在电极支撑件上的至少一个有源电极。该仪器适用于耦合到高频电源或电外科发生器。每个有源电极适于从目标部位移除组织和/或用于靶组织的局部凝固。在一个实施例中，该仪器适用于腹腔镜手术。

