



- (51) International Patent Classification:
A61B 17/10 (2006.01)
- (21) International Application Number:
PCT/US2011/001494
- (22) International Filing Date:
25 August 2011 (25.08.2011)
- (25) Filing Language: English
- (26) Publication Language: English
- (72) Inventors; and
- (71) Applicants : SCOTT, Stephen, J. [US/US]; 244 Bless Us Drive, Wentzville, MO 63385 (US). SMITH, Jeffrey [US/US]; 10 Via Ricasol #A416, Irvine, CA 92612 (US).
- (74) Agent: ROLNICKI, Joseph, M.; Evans & Dixon LLC, 211 N. Broadway, Suite 2500, Saint Louis, MO 63102 (US).
- (81) Designated States (unless otherwise indicated, for every kind of national protection available): AE, AG, AL, AM,

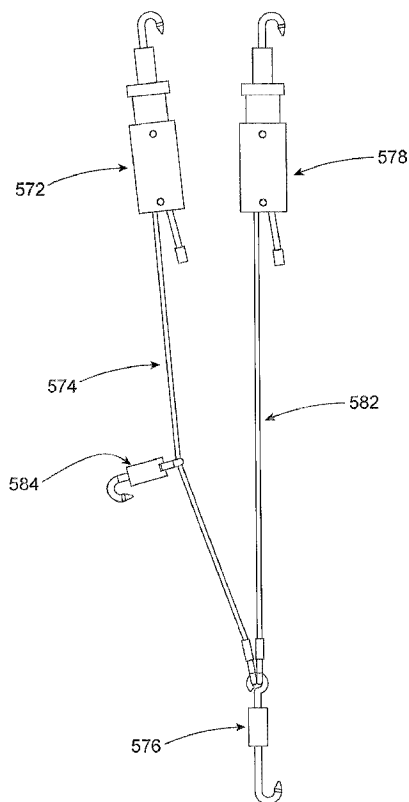
AO, AT, AU, AZ, BA, BB, BG, BH, BR, BW, BY, BZ, CA, CH, CL, CN, CO, CR, CU, CZ, DE, DK, DM, DO, DZ, EC, EE, EG, ES, FI, GB, GD, GE, GH, GM, GT, HN, HR, HU, ID, IL, IN, IS, JP, KE, KG, KM, KN, KP, KR, KZ, LA, LC, LK, LR, LS, LT, LU, LY, MA, MD, ME, MG, MK, MN, MW, MX, MY, MZ, NA, NG, NI, NO, NZ, OM, PE, PG, PH, PL, PT, QA, RO, RS, RU, SC, SD, SE, SG, SK, SL, SM, ST, SV, SY, TH, TJ, TM, TN, TR, TT, TZ, UA, UG, US, UZ, VC, VN, ZA, ZM, ZW.

- (84) Designated States (unless otherwise indicated, for every kind of regional protection available): ARIPO (BW, GH, GM, KE, LR, LS, MW, MZ, NA, SD, SL, SZ, TZ, UG, ZM, ZW), Eurasian (AM, AZ, BY, KG, KZ, MD, RU, TJ, TM), European (AL, AT, BE, BG, CH, CY, CZ, DE, DK, EE, ES, FI, FR, GB, GR, HR, HU, IE, IS, IT, LT, LU, LV, MC, MK, MT, NL, NO, PL, PT, RO, RS, SE, SI, SK, SM, TR), OAPI (BF, BJ, CF, CG, CI, CM, GA, GN, GQ, GW, ML, MR, NE, SN, TD, TG).

Declarations under Rule 4.17:
— of inventorship (Rule 4.17(iv))

[Continued on next page]

(54) Title: APPARATUS AND METHOD FOR INTRA-ABDOMINALLY MOVING A FIRST INTERNAL ORGAN TO A POSITION AWAY FROM A SECOND INTERNAL ORGAN AND THEN HOLDING THE FIRST INTERNAL ORGAN IN THE POSITION WITHOUT MANUAL INPUT



(57) Abstract: An apparatus including a flexible length of cord and three tissue connectors positioned at the opposite ends of the cord and at an intermediate position of the cord is designed to be laparoscopically inserted through the abdominal wall and into the abdominal cavity, and used to move a first internal organ to a position away from a second internal organ where the apparatus holds the first internal organ in the position without further manual input, thereby providing surgical access to the second internal organ.

WO 2013/028145 A1

Published:

— *with international search report (Art. 21(3))*

**APPARATUS AND METHOD FOR INTRA-ABDOMINALLY MOVING A FIRST
INTERNAL ORGAN TO A POSITION AWAY FROM A SECOND INTERNAL
ORGAN AND THEN HOLDING THE FIRST INTERNAL ORGAN IN THE
POSITION WITHOUT MANUAL INPUT**

This patent application is a continuation-in-part application from application serial no. _____, which is a U.S. National Stage application from international application PCT/US2010/025425, which claims the benefit of priority date of February 25, 2009 of the U.S. Provisional application serial no. 61/155,409.

BACKGROUND OF THE INVENTION

1. Field of the Invention

[001] The present invention is directed to an apparatus and its method of use in intra-abdominally moving a first internal organ to a position away from a second internal organ where the apparatus holds the first internal organ in the position without further manual input. More specifically, the present invention is directed to an apparatus that is inserted through the abdominal wall and into the abdominal cavity, and the method of using the apparatus in the abdominal cavity to move a human liver to a position away from a human stomach where the apparatus holds the liver in the position without further manual input, thereby providing surgical access to the stomach.

2. Description of the Related Art

[002] In laparoscopic surgical procedures, it is often necessary to make incisions through the abdominal wall for the sole purpose of providing access to the

abdominal cavity for surgical graspers or other similar types of retracting instruments that are used to move one internal organ to a position away from a second internal organ to gain surgical access to the second internal organ. The incisions made for the surgical graspers or similar retracting instruments are in addition to the incisions made in the abdominal wall for the surgical instruments used in performing the surgical procedure on the second organ.

[003] Furthermore, it is often necessary that an additional surgeon or surgical assistant be present solely for the purpose of manipulating the surgical graspers or other similar retracting instruments in moving the first internal organ to a position away from the second internal organ, and then manually holding the first internal organ in the position during the surgical procedure performed on the second internal organ.

[004] The need for the additional surgical personnel to manipulate and hold the surgical graspers or other similar retracting instruments during the surgical procedure increases the costs of surgery. In addition, the additional incisions in the abdominal wall required for the surgical graspers or other similar retracting instruments often results in additional discomfort to the patient following surgery and additional scarring.

[005] What is needed to overcome these disadvantages associated with the above-described type of laparoscopic surgical procedure is an apparatus that can be operated to intra-abdominally move a first internal organ to a position away from a second internal organ and then hold the first internal organ in the position without requiring additional manual input other than that provided by the surgeon and

without requiring additional abdominal incisions other than those required for the surgery.

SUMMARY OF THE INVENTION

[006] The present invention overcomes the above-described shortcomings of laparoscopic surgical procedures by providing an apparatus that can be inserted into the abdominal cavity through the same incision to be used in a laparoscopic surgery procedure, and the method of using the apparatus to move or retract a first internal organ, for example the liver, away from a second internal organ, for example the stomach, and then hold the first internal organ in the retracted position providing surgical access to the second internal organ without requiring further manual input.

[007] The apparatus is constructed of component parts that are often used in laparoscopic as well as other types of surgical procedures. The component parts will be described herein using their common understood names and their functions, without going into details of the particular constructions of the component parts.

[008] The basic construction of the apparatus of the invention includes a length of cord. The cord could be comprised of a first cord segment having a flexible length with opposite first and second ends, and a second cord segment having a flexible length with opposite first and second ends. The cord segments could be provided by lengths of suture, lengths of tubing such as IV tubing, lengths of umbilical tape or elastic strips, or other equivalent cord constructions. The first and second cord segments could be separate cord segments that are attached together, or could be two cord segments of a single continuous length of cord.

[009] In one embodiment of the apparatus, first, second, and third separate tissue connectors are attached to the first and second cord segments. The tissue connectors can be any type of known tissue connector that can be manually manipulated to connect to body tissue, and then manually manipulated to be removed from the body tissue without leaving any significant damage to the body tissue. In addition, the tissue connectors can be biocompatible tissue connectors that are designed to be left in the abdominal cavity after the surgery. Some examples of such tissue connectors include suture needles, 'T' bars, graspers, barbed needles, hooks, clasps, rivet assemblies, or any other equivalent type of connector. The first and third tissue connectors are attached to the opposite ends of the first cord segment and the second and third tissue connectors are attached to the opposite ends of the second cord segment. This positions the first and second tissue connectors at the opposite ends of the combined lengths of the first and second cord segments, and positions the third tissue connector at an intermediate position of the combined lengths of the first and second cord segments.

[010] In the use of the apparatus according to the method of the invention, the apparatus is first manually passed through the abdominal wall, for example through an incision or a cannula in the abdominal wall, and is positioned in the abdominal cavity in the area of the first and second internal organs. The third tissue connector is then manually connected to tissue adjacent the first internal organ. This positions the ends of the first and second cord segments connected to the third tissue connector between the first and second internal organs and on an opposite side of the first internal organ from the abdominal wall. The first tissue

connector attached to the opposite end of the first cord segment from the third tissue connector is manually moved causing the length of the first cord segment to move and engage across the first internal organ and to move the first internal organ toward the position away from the second internal organ. The first tissue connector is then manually connected to the abdominal wall.

[011] The second tissue connector attached to the opposite end of the second cord segment from the third tissue connector is then manually moved causing the second cord segment to move and engage across the first internal organ and move the first internal organ toward the position away from the second internal organ. The second tissue connector is then manually connected to the abdominal wall.

[012] In the above matter, the first and second cord segments engaging across the first internal organ hold the first internal organ at the position away from the second internal organ without further manual input. This provides surgical access to the second internal organ.

[013] In a further embodiment of the apparatus of the invention, the apparatus is comprised of a cord having a continuous flexible length with opposite first and second ends. A needle is attached to one end of the length of cord and a knot is formed in the opposite end of the length of cord.

[014] According to the method of use of this embodiment of the apparatus, the apparatus is first positioned inside the abdominal cavity in the same manner as the previously-described embodiment. The knotted end of the length of cord is then connected to tissue adjacent the first internal organ by first passing the needle through the tissue and then manually pulling the length of cord through the tissue.

This attaches the knotted end of the cord to the tissue between the first and second internal organs.

[015] The needle is then passed through the inter-abdominal wall and manually moved back into the abdominal cavity, causing a first segment of the length of cord to engage across the first internal organ and move the first internal organ toward the position away from the second internal organ.

[016] The needle is then again inserted through the inter-abdominal wall at a location spaced from the first insertion of the needle through the inter-abdominal wall, and the needle and length of cord are pulled manually into the abdominal cavity.

[017] The needle and the end of the length of cord attached to the needle are then passed through the knot formed at the opposite end of the length of cord and pulled tight, causing a second segment of the length of cord to engage across and move the first internal organ toward the position away from a second internal organ. A knot is then tied between the opposite ends of the length of cord and the portion of the cord extending from the knot to the needle is cut and removed with the needle from the abdominal cavity. The length of cord left in the abdominal cavity forms a triangular loop with first and second cord segments that engage across and hold the first internal organ in the position away from the second internal organ without manual input. In this manner, surgical access is provided to the second internal organ without manual input.

[018] A still further embodiment of the apparatus of the invention is comprised of a cord having a continuous flexible length with opposite first and second ends, and a

tissue connector assembly with a releasable one-way cord lock connected to an intermediate portion of the cord.

[019] The tissue connector assembly has a base formed as a cylindrical housing. The base housing has a length with opposite first and second ends and a hollow interior bore extending through the housing. A rod is attached to the base and is positioned in the interior bore adjacent the housing second end.

[020] A first tissue connector is provided on the base and extends from the base first end. As in previous embodiments, the tissue connector can be any known type of tissue connector.

[021] The intermediate portion of the cord length is attached to the base by being wrapped around the rod in the base housing. A first portion or first percentage of the cord length extends from the cord intermediate portion and from the base second end to the cord first end. A second portion or second percentage of the cord length extends from the cord intermediate portion and from the base second end to the cord second end.

[022] A releasable one-way lock is mounted in the interior bore of the base for movement of the lock between first and second positions of the lock relative to the base. The lock is biased by a spring toward the first position. In the first position of the lock relative to the base, the lock engages with the intermediate portion of the cord wrapped around the rod and allows the cord first portion to be pulled from the base second end to thereby increase a length or percentage of the cord first portion while decreasing a length or percentage of the cord second portion, but the lock prevents the cord second portion from being pulled from the base second end. In the second position of the lock relative to the base the lock is disengaged from

the cord and allows the cord second portion to be pulled from the base second end to thereby increase the length or percentage of the cord second portion while decreasing the length or percentage of the cord first portion.

[023] A second tissue connector is provided at the cord second end. Again, the second tissue connector can be any known type of tissue connector. A percentage of the cord length extends between the first and second tissue connectors. This percentage of the cord length is adjustable.

[024] There is an actuator on the base that is operatively connected to the lock. The actuator is movable between first and second positions of the actuator relative to the base. When the actuator is moved from the first position to its second position it causes the lock to move from its first position to its second position and releases the one way lock. The spring bias of the lock also biases the actuator from its second position toward its first position.

[025] In the use of this embodiment of the apparatus according to the method of the invention, the apparatus is first positioned inside the abdominal cavity in the same manner as the previously described embodiments.

[026] With the apparatus positioned in the abdominal cavity, the second tissue connector at the cord's second end is connected to tissue adjacent to the first internal organ or to the organ itself. The tissue connector assembly with the releasable one-way cord lock is then grasped at the actuator and moved toward the abdominal wall, causing the cord second portion to be extended across the first internal organ. When the cord second portion is pulled tight continued movement of the tissue connector assembly causes the actuator to move to its second position. This releases the lock and allows the cord second portion to be pulled

from the base second end increasing the length or percentage of the cord second portion and decreasing the length or percentage of the cord first portion. The first tissue connector is then connected to the abdominal wall and the actuator is released, causing the actuator and the lock to move to their first position due to the bias of the spring. The cord first portion is then grasped and pulled from the second end of the base. This in turn causes the length or percentage of the cord second portion to decrease. As the cord first portion is pulled from the base second end the length or percentage of the cord second portion continues to decrease and causes the cord second portion to engage across the first internal organ and move the first internal organ toward the position away from the second internal organ. With the releasable one-way lock biased to the first position relative to the base, the cord second portion cannot be pulled from the base.

[027] In the above manner, the shortened length of the cord second portion extending between the first tissue connector connected to the abdominal wall and the second tissue connector connected to the body tissue adjacent the first internal organ engages across the first internal organ and holds the first internal organ at the position away from the second internal organ without further manual input. This provides surgical access to the second internal organ.

[028] When it is desired to remove the apparatus of the invention, the actuator is grasped and moved from its first position to its second position relative to the apparatus base. This in turn causes the lock to move from its first position to its second position releasing the lock, and allows the cord second portion to be pulled from the base second end increasing the length or percentage of the cord second portion while decreasing the length or percentage of the cord first portion. This

allows the cord second portion to disengage from the first internal organ and produces a sufficient length of the cord second portion to allow the first tissue connector to be removed from the abdominal wall and the second tissue connector at the cord second end to be removed from the body tissue adjacent the first internal organ or from the organ. The apparatus then can be removed from the abdominal cavity.

[029] As described above, the embodiments of the apparatus of the invention and their methods of use enable intra-abdominally moving a first internal organ to a position away from a second internal organ where each of the embodiments of the apparatus holds the first internal organ in the position without manual input.

DESCRIPTION OF THE DRAWING FIGURES

[030] Further features of the apparatus of the invention and its method of use are set forth in the following detailed description of the apparatus and method and are shown in the drawing figures.

[031] Figure 1 is a plan view of one embodiment of the apparatus of the invention.

[032] Figure 2 is a plan view of a further embodiment of the apparatus of the invention.

[033] Figure 3 is a plan view of a still further embodiment of the apparatus of the invention.

[034] Figure 4 is a representation of the apparatus of Figure 1 being inserted into the abdominal cavity.

[035] Figure 5 is a representation of the apparatus of Figure 1 being used according to the method of the invention.

[036] Figure 6 is a representation of the apparatus of Figure 2 in use according to the method of the invention.

[037] Figure 7 is a representation of the apparatus of Figure 3 in use according to the method of the invention.

[038] Figures 8A-8E represent the insertion of one embodiment of the apparatus into the abdominal cavity and one method of use of the apparatus.

[039] Figures 9A-9E represent the insertion of a further embodiment of the apparatus into the abdominal cavity and the method of using the apparatus.

[040] Figures 10A and 10B represent the insertion of a further embodiment of the apparatus into the abdominal cavity and the method of using the apparatus.

[041] Figures 11A and 11B represent a further embodiment of the apparatus and its method of use.

[042] Figures 12A and 12B represent a further embodiment of the apparatus and its method of use.

[043] Figures 13A and 13B represent a further embodiment of the apparatus and its method of use.

[044] Figures 14A-14C represent a further embodiment of the apparatus and its method of use.

[045] Figures 15A and 15B represent a further embodiment of the apparatus and its method of use.

[046] Figures 16A and 16B represent a further embodiment of the apparatus and its method of use.

[047] Figure 17 represents a further embodiment of the apparatus and its method of use.

[048] Figures 18A and 18B represent a further embodiment of the apparatus and its method of use.

[049] Figures 19A and 19B represent a further embodiment of the apparatus and its method of use.

[050] Figures 20A and 20B represent a further embodiment of the apparatus and its method of use.

[051] Figures 21A and 21B represent a further embodiment of the apparatus and its method of use.

[052] Figures 22A and 22B represent a further embodiment of the apparatus and its method of use.

[053] Figure 23 represents a further embodiment of the apparatus and its method of use.

[054] Figures 24A-24C represent component parts of a further embodiment of the apparatus.

[055] Figure 25 represents a component part of a further embodiment of the apparatus.

[056] Figure 26 represents a component part of a further embodiment of the apparatus.

[057] Figures 27A and 27B represent a further embodiment of the apparatus.

[058] Figures 28A and 28B represent a further embodiment of the apparatus.

[059] Figures 29A and 29B represent a further embodiment of the apparatus.

[060] Figures 30A and 30B represent a further embodiment of the apparatus.

[061] Figure 31 represents a further embodiment of the apparatus.

[062] Figure 32 represents a further embodiment of the apparatus.

[063] Figure 33 represents a component part of an embodiment of the apparatus.

[064] Figure 34 represents a component part of an embodiment of the apparatus.

[065] Figure 35 represents a component part of an embodiment of the apparatus.

[066] Figure 36 represents a component part of an embodiment of the apparatus.

[067] Figure 37 represents a component part of an embodiment of the apparatus.

[068] Figure 38 represents a component part of an embodiment of the apparatus.

[069] Figures 39A-39C represent component parts of an embodiment of the apparatus.

[070] Figures 40A and 40B represent component parts of an embodiment of the apparatus.

[071] Figure 41 represents a component part of an embodiment of the apparatus.

[072] Figure 42 represents a component part of an embodiment of the apparatus.

[073] Figure 43 represents a component part of an embodiment of the apparatus.

[074] Figures 44A and 44B represent component parts of an embodiment of the apparatus.

[075] Figures 45A-45E represent component parts of an embodiment of the apparatus.

[076] Figures 46A-46E represent component parts of an embodiment of the apparatus and its method of use.

[077] Figures 47A-47D represent component parts of an embodiment of the apparatus and its method of use.

[078] Figures 48A-48D represent component parts of an embodiment of the apparatus and its method of use.

[079] Figures 49A and 49B represent component parts of an embodiment of the apparatus and its method of use.

[080] Figures 50A and 50B represent component parts of an embodiment of the apparatus and its method of use.

[081] Figures 51A-51 E represent a method of positioning an embodiment of the apparatus in an abdominal insertion device.

[082] Figures 52A and 52B represent embodiments of the apparatus and an insertion device and the method of mounting the apparatus on the insertion device.

[083] Figure 53 represents embodiments of the apparatus and an insertion device and a method of mounting the apparatus on the insertion device.

[084] Figure 54 represents embodiments of the apparatus and an insertion device and a method of mounting the apparatus in the insertion device.

[085] Figures 55A-55C represent an embodiment of the apparatus and a method of using the apparatus.

[086] Figures 56A-56C are views of a further embodiment of the apparatus of the invention that employs a tissue connector with a releasable one-way cord lock.

[087] Figures 57A-57C are views of the tissue connector apparatus of Figures 56A-56C but rotated 90°. Figures 58A-58C are views of the tissue connector apparatus similar to those of Figures 56A-56C, but with the releasable one-way cord lock moved to an unlocked position.

[088] Figures 59A-59C are views of the surgical tissue connector apparatus shown in Figures 58A-58C, but rotated 90°.

[089] Figures 60A-60C show a further embodiment of the surgical tissue connector apparatus with a releasable one-way cord lock.

[090] Figures 61A-61C are views of the tissue connector apparatus of Figures 60A-60C, but rotated 90°.

[091] Figures 62A-62C are views of the tissue connector apparatus similar to those of Figures 60A-60C, but with the releasable one-way cord lock moved to the unlocked position.

[092] Figures 63A-63C are views similar to those of Figures 62A-62C, but rotated 90°.

[093] Figures 64-67 are representations of a method of using either of the embodiments of the surgical tissue connector apparatus shown in Figures 56A-56C or 60A-60C.

[094] Figure 68 is a view of a still further embodiment of the apparatus comprising two cord lengths and four tissue connectors.

DETAILED DESCRIPTION OF THE PREFERRED EMBODIMENT

[095] Figure 1 shows one embodiment 12 of the apparatus for intra-abdominally moving a first internal organ to a position away from a second internal organ and then holding the first internal organ in the position without manual input. As stated earlier, the apparatus 12 is constructed of component parts that are often used in laparoscopic instruments and procedures as well as other types of surgical instruments and procedures. Because such component parts are known, the component parts that make up the apparatus 12 of the invention will be described herein using their common understood names and functions, without going into the details of the particular constructions of the component parts. As is conventional with laparoscopic apparatus, the component parts of the apparatus are dimensioned to be inserted through an incision in the abdominal wall or through a

cannula extending through the abdominal wall to position the apparatus in the abdominal cavity.

[096] The basic construction of the apparatus 12 of the invention includes a length of cord. In the example of Figure 1 the cord length is 10 inches, but the size of the apparatus 12 could change depending on the size of the patient in which the apparatus is used. In the embodiment shown in Figure 1, the cord is comprised of a first cord segment 14 having a flexible length with opposite first 16 and second 18 ends, and a second cord segment 22 having a flexible length with opposite first 24 and second 26 ends.

[097] The cord segments 14, 22 could be provided by lengths of suture, lengths of tubing such as IV tubing, lengths of umbilical tape or elastic strips, or other equivalent cord constructions. The tubing or tape configurations of the cord segments have the advantage of being less likely to dig into or cut into the first internal organ in use of the apparatus to be described. The first 14 and second 22 cord segments could be separate cord segments that are attached directly together, or separate cord segments that are attached by way of a further cord segment 28 or some other component part of the apparatus, or two cord segments of a single continuous length of cord such as the two cord segments 14a, 22a shown in Figure 2.

[098] First 32, second 34, and third 36 separate tissue connectors are attached to the first 14 and second 22 cord segments. The tissue connectors 32, 34, 36 can be any type of known tissue connector that can be manually manipulated to connect to body tissue, and then manually manipulated to be removed from the body tissue 12 without leaving any significant damage to the body tissue. In addition, the tissue

connectors 32, 34, 36 could be biocompatible tissue connectors that are designed to be left in the abdominal cavity after the surgical procedure is completed. Some examples of tissue connectors include suture needles, 'T' bars, surgical graspers, barbed needles, hooks, clasps, rivet assemblies, or any other equivalent type of connector. In the apparatus of the invention, it is not necessary that all three tissue connectors 32, 34, 36 be the same type of tissue connector. Because various different types of tissue connectors may be employed with the apparatus 12 of the invention, the three tissue connectors 32,34,36 of the apparatus 12 are represented schematically in the drawing figures. The first 32 and third 36 tissue connectors are attached to the opposite ends of the first cord segment 14. The third tissue connector 36 is also attached to one end of the second cord segment 22, with the second tissue connector 34 being connected to the opposite end of the second cord segment 22. This positions the first 32 and second 34 tissue connectors at the opposite ends of the combined lengths of the first 14 and second 22 cord segments, and positions the third tissue connector 36 at an intermediate position of the combined length of the first 14 and second 22 cord segments. In Figure 1, the first 32 and second 34 tissue connectors are shown connected to the respective first end 16 of the first cord segment 14 and the first end 24 of the second cord segment 22 through the intermediary of additional cord segments 38, 40. The third tissue connector 36 is shown connected to the second end 18 of the first cord segment 14 and the second end 26 of the second cord segment 22 through the intermediary of a further cord segment 28. Figure 2 shows the apparatus 12 with the first 32 and second 34 tissue connectors connected directly to the respective first end 16 of the first cord segment 14 and the first end 24 of the

second cord segment 22. Figure 2 also shows the third tissue connector 36 connected directly to the second ends 18, 26 of the first cord segment 14 and the second cord segment 22.

[099] Figures 4 and 5 illustrate an example of the use of the apparatus 12 of Figure 1 according to the method of the invention. In use, the apparatus 12 is first manually passed through the abdominal wall 42, for example through an incision or a cannula 44 in the abdominal wall 42, and is positioned in the abdominal cavity 46 in the area of the first 48 and second 50 internal organs. In Figure 4, the first internal organ 48 represented is the human liver, and the second internal organ 50 represented is the human stomach.

[0100] The third tissue connector 36 of the apparatus is then manually connected to tissue 52 adjacent the first internal organ 48 and between the first 48 and second 50 internal organs. In the example shown in Figure 4, the tissue 52 is the crus of the diaphragm. Connection of the third tissue connector 36 to the tissue 52 positions the second ends 18, 26 of the first 14 and second 22 cord segments connected to the third tissue connector 32 between the first 48 and second 50 internal organs and on an opposite side of the first internal organ 48 from the abdominal wall 42.

[0101] The first tissue connector 32 attached to the opposite end 16 of the first cord segment 14 from the third tissue connector 36 is then manually moved causing the length of the first cord segment 14 to move and engage across the first internal organ 48. Continued movement of the first tissue connector 32 causes the first cord segment 14 engaging across the first internal organ 48 to move the first

internal organ toward a position away from the second internal organ 50. The first tissue connector 32 is then manually connected to the inner abdominal wall 42.

[0102] The second tissue connector 34 attached to the opposite end 24 of the second cord segment 22 from the third tissue connector 36 is then manually moved causing the second cord segment 22 to move and engage across the first internal organ 48. Continued movement of the second tissue connector 34 causes the second cord segment 22 engaging across the first internal organ 48 to move the first internal organ 48 toward the position away from the second internal organ 50. The second tissue connector 34 is then manually connected to the inner abdominal wall 42.

[0103] With the apparatus 12 connected between the tissue 52 and the inner abdominal wall 42 in the manner discussed above, the first cord segment 14 and the second cord segment 22 engage across the first internal organ 48 and hold the first internal organ 48 at the position away from the second internal organ 50 without further manual input. This provides surgical access to the second internal organ 50. Without requiring manual holding or restraining of the first internal organ 48 in the position away from the second internal organ 50.

[0104] Figure 6 is a representation of the apparatus of Figure 2 that has been connected between the tissue 52 and the inner abdominal wall 42 according to the same method as the apparatus of Figure 1 described above.

[0105] In a further embodiment of the apparatus of the invention shown in Figure 3, the apparatus 54 is comprised of a single cord 56 having a continuous flexible length with opposite first 58 and second 60 ends. A tissue connector in the form of

a needle 62 is attached to the first end 58 of the length of cord 56. At the opposite second end 60 of the length of cord 56, the cord is formed in a knot 64.

[0106] The method of using the embodiment of the apparatus 54 shown in Figure 3 is illustrated in Figure 7. The apparatus 54 is first positioned inside the abdominal cavity in the same manner as the previously described embodiments. The knotted end 64 of the length of cord is then connected to the tissue 52 adjacent the first internal organ 48 by first passing the needle 62 through the tissue 52 and then manually pulling the needle 62 and the attached length of cord 56 through the tissue 52. This attaches the knotted second end 64 of the length of cord 56 to the tissue 52 between the first 48 and second 50 internal organs.

[0107] The needle 62 is then passed through the inter-abdominal wall 42 and the needle 62 and the attached length of cord 56 are pulled from the insertion site 72 back into the abdominal cavity 46. This causes a first segment 74 of the cord length 56 to move into engagement with and across the first internal organ 48. The engagement of the first cord segment 74 with the first internal organ 48 moves the first internal organ 48 toward the position away from the second internal organ 50.

[0108] The needle 62 is then again inserted through the inter-abdominal wall 42 at a second insertion location 76 spaced from the first insertion location 72. The needle 62 and the attached length of cord 56 are pulled manually through the second insertion 76 into the abdominal cavity 46 until an intermediate section of cord 78 extends between the two insertion sites 72,76.

[0109] The needle 62 and the attached length of cord 56 are then passed through the knot 64 formed at the opposite end of the length of cord 56 and are pulled tight. This causes a second cord segment 82 of the length of cord 56 to

engage across and move the first internal organ 48 toward the position away from the second internal organ 50. The length of cord 56 is pulled tight and a knot is tied between the opposite ends of the cord at the knot 64 on the cord second end 60. The portion of the length of cord 54 extending from the knot 64 to the needle 62 is then cut and removed from the abdominal cavity. The length of cord 54 left in the abdominal cavity forms a triangular loop with the first 56 and second 82 cord segments extending across the first internal organ 48 and holding the first internal organ in the position away from the second internal organ 50 without manual input. In this manner, surgical access is provided to the second internal organ 50 without manually holding the first internal organ 48 in its retracted position.

[0110] Figures 8A-8E represent one method of inserting the apparatus of the invention into the abdominal cavity and the method of using the apparatus. The embodiment of the apparatus 12 shown in these drawing figures has a pair of Keith needles 80, 82 as the first and second tissue connectors, and a 'T' bar 84 as the third tissue connector. The apparatus 12 is first positioned inside an insertion device 86 in the form of a hollow narrow tube. The insertion device 86 is then inserted through a trocar or cannula 44 that has been positioned in the abdominal wall 42 in a conventional manner. Once inside the abdominal cavity 46, the apparatus 12 is removed from the interior of the insertion device 86 and the insertion device is removed from the abdominal cavity through the cannula 44. The 'T' bar 84 or the third tissue connector is then passed through the body tissue 52, i.e., the right diaphragm crus as described earlier. Once the 'T' bar 84 is passed through the tissue 52, it is rotated to its substantially 90 degree position relative to its pathway through the tissue 52 as shown in Figure 8C. The apparatus 12 is then

pulled from the Keith needles 80, 82. As represented in Figure 80, the Keith needles 80, 82 are then passed through the abdominal wall 42 and the apparatus is pulled tight against the first internal organ 48, i.e., the liver. The needles 80, 82 are then pulled at the exterior of the abdominal wall 42, causing the apparatus to move the first internal organ 48 away from the second internal organ, i.e., the stomach. A pair of tension clasps 88, 90 are attached to the respective first 14 and second 22 cord segments of the apparatus on the exterior of the abdominal wall 42 to hold the apparatus in its position across the first internal organ 48 in the abdominal cavity 46.

[0111] Figures 9A-9E represent a method of using an embodiment of the apparatus 12 that is similar to that shown in Figures 8A-8E and described above. In this example, the apparatus 12 also employs the 'T' bar 84 as its third tissue connector. However, there is no needle provided on the first cord segment 14 and there is no needle provided on the second cord segment 22. In this embodiment of the apparatus 12, the first cord segment 14 is a length of suture having a free end 92 opposite the 'T' bar 84 and the second cord segment 22 is a length of suture also having a free end 94 opposite the 'T' bar 84. The apparatus 12 is shown in Figure 9A as being positioned in the abdominal cavity 46 using the insertion device 86 in the same manner described earlier with reference to the method of Figures 8A-8E. The apparatus 12 of Figure 9A is also initially used according to the same method of Figures 8A-8E in that the "T" bar 84 is passed through the body tissue 52 and is positioned substantially 90° relative to the pathway through the tissue. A pair 18 of GraNee needles 96, 98 are then passed through the abdominal wall 42. One of the GraNee needles 96 grabs the suture free end 92 of the first cord

segment 14 and the other GraNee needle 98 grabs the suture free end 94 of the second cord segment 22. The GraNee needles 96, 98 are then withdrawn through the abdominal wall 42 pulling the suture free ends 92, 94 through the abdominal wall. The suture free ends 92, 94 are then secured to the abdominal wall using a pair of clamps 88, 90 as was done in the previously-described embodiment of Figures 8A-8E.

[0112] Figures 10A and 10B are a representation of the method of the invention practiced using an ENDO STITCH® device marketed by United States Surgical Corporation. Figure 10A represents the distal end of the ENDO STITCH® 102 being inserted through the cannula 44 in the abdominal wall 42 to a position adjacent the diaphragm crus 52. As is conventional, the pair of jaws 104, 106 at the ENDO STITCH® distal end 102 hold a needle 108 and a length of suture 110. The ENDO STITCH® 102 is manually actuated to pass the needle 108 through the tissue 52 of the crus from one jaw 104 of the ENDO STITCH® to the opposite jaw 106 of the ENDO STITCH®. The length of suture 110 is then removed from the abdominal cavity 46 through the cannula 44 and is pulled tight, causing the length of suture 110 to move and hold the first internal organ away from the second internal organ in substantially the same manner as described earlier.

[0113] Figures 11A and 11 B represent a further embodiment of the apparatus 12 and its method of use. The embodiment of the apparatus 12 shown in Figures 11A and 11B and its method of use are substantially the same as that of earlier-described embodiments, except that the 'T' bar of the previously-described embodiments is replaced by a "J" hook locking clasp 112. Figure 11A shows the locking clasp 112 in its open position prior to the hook portion of the clasp being

passed through the tissue 52 of the diaphragm crus. Figure 11B shows the locking clasp 112 after the hook of the clasp has been passed through the tissue 52 and the clasp has been locked. The method of further using the apparatus to move and hold an internal organ is substantially the same as that of earlier-described embodiments.

[0114] Figures 12A and 12B show a further embodiment of the apparatus 12 and its method of use. The construction of the embodiment of the apparatus 12 shown in Figures 12A and 12B is substantially the same as earlier described embodiments, except that the 'T' bar or locking clasp is replaced by a barbed needle 114. The method of using the embodiment of the apparatus shown in Figures 12A and 12B is substantially the same as that of earlier described embodiments, except that the barbed needle 114 is passed through the tissue 52 of the diaphragm crus until the barb of the needle emerges from the tissue as shown in Figure 12B. This secures the apparatus to the tissue 52. Further use of the apparatus to move and hold an internal organ is substantially the same as that of earlier-described embodiments.

[0115] Figures 13A and 13B show a further embodiment of the apparatus 12 of the invention that is substantially the same as that as earlier-described embodiments except that the third tissue connector or 'T' bar is replaced by a resilient biased clasp 116. In the method of using the apparatus of Figures 13A and 13B, the opposite arms 118, 120 of the clasp 116 are compressed to open the jaws 122, 124 of the clasp as shown in Figure 13A. The jaws 122, 124 are then positioned around the tissue 52 of the diaphragm crus and are allowed to close, thereby securing the clasp 116 to the tissue 52. The subsequent method of using

the apparatus shown in Figures 13A and 13B is substantially the same as that of previously-described embodiments of the apparatus.

[0116] Figure 14A-14C show a further embodiment of the apparatus 12 that is substantially the same as that of previously-described embodiments except that the third tissue connector is a two-piece rivet assembly. The assembly is comprised of a pin 126 having an enlarged point 128 and a cap 130 having a circular center opening 132. In the method of using the apparatus of Figures 14A-14C, the pin 126 is first inserted through the tissue 52 of the diaphragm crus until the point 128 projects from the opposite side of the tissue. The point 128 is then inserted through the center opening 132 of the cap 130, thereby securing the pin 126 and the cap 130 to the tissue 152. The subsequent steps of using the apparatus of Figures 14A-14C is substantially the same as that of earlier-described embodiments of the apparatus.

[0117] Figures 15A and 15B show a further embodiment of the apparatus 12 that has substantially the same construction of earlier-described embodiments of the apparatus except for the first and second tissue connectors being a pair of "J" shaped hooks 134, 136. In the method of using the embodiment of the apparatus shown in Figures 15A and 15B, the first cord segment 14 and the second cord segment 22 are secured to the inner abdominal wall 42 by passing the hooks 134, 136 through the tissue of the inner abdominal wall. Apart from this, the method of using the apparatus shown in Figures 15A and 15B is substantially the same as that of earlier-described embodiments of the apparatus.

[0118] Figures 16A and 16B represent a further embodiment of the apparatus and its method of use that are substantially the same as that of previously-described

embodiments, except for the first and second tissue connectors being a pair of "J" hook locking clasps 138, 140. In the method of using the apparatus of Figures 16A and 16B, the hook portions of the locking clasps 138, 140 are passed through the tissue of the inner abdominal wall 42 and then are locked closed. This secures the first cord segment 14 and the second cord segment 22 to the inner abdominal wall. Apart from this, the method of using the apparatus of the invention shown in Figures 16A and 16B is substantially the same as that of earlier-described embodiments of the apparatus.

[0119] Figures 17 shows a representation of an embodiment of the apparatus where the first and second tissue connectors are provided as a pair of resilient, biased clasps 142, 144 that have substantially the same construction of the earlier described clasp 116. The clasps 142, 144 are secured to the inner abdominal wall 42 by first opening the clasps and positioning tissue of the inner abdominal wall between the open jaws of the clasps, and then allowing the jaws of the clasps to close over the tissue. This secures the first cord segment 14 and the second cord segment 22 to the inner abdominal wall. Apart from this, the method of using the apparatus represented in Figure 17 is substantially the same as that as earlier described embodiments of the apparatus.

[0120] Figures 18A and 18B show an embodiment of the apparatus and its method of use that is substantially the same as that of Figure 7. The embodiment of Figures 18A and 18B differs from that of the Figure 7 embodiment in that the free ends 146, 148 of the length of suture 150 are tied in a knot completing the triangular loop configuration of the length of suture 150 at a location that is displaced from the portion of the suture 150 passed through the tissue 52 of the

diaphragm crus. Apart from this, the method of using the apparatus of the invention shown in Figures 18A and 18B is substantially the same as that of the embodiment of the apparatus shown in Figure 7.

[0121] Figures 19A and 19B show a further embodiment of the apparatus and its method of use. The apparatus shown in these drawing figures is comprised of a length of cord 152 with a circular pledget 154 secured at one end of the cord and a needle, for example a Keith needle 156, secured to the opposite end of the cord. The cord 152 could be a length of suture or other similar material. In the method of using the apparatus shown in Figures 19A and 19B, the needle 156 is first passed through the abdominal wall 42 and into the abdominal cavity 46. The needle 156 is then passed through the tissue 52 of the diaphragm crus. The needle 156 is then again passed through the abdominal wall 42 to the exterior of the abdomen and is pulled tight. This results in the length of cord 152 engaging against and moving the first internal organ away from the second internal organ in substantially the same manner as previously-described embodiments. The tight length of cord 152 is then secured in place by a clasp 158 attached to the length of cord 152 against the exterior of the abdominal wall 42.

[0122] Figures 20A and 20B show a representation of a further embodiment of the apparatus and its method of use. In Figure 20A, the apparatus is shown comprised of a length of cord 160 having a circular pledget 162 at one end and a needle, for example a Keith needle 164, at the opposite end. The apparatus also includes a second shorter length of cord 166 with a 'T' bar 168 at one end and a loop 170 formed in the opposite end. In the embodiment, the cords 160, 166 may be suture or other similar materials. The method of using the apparatus is

represented in Figure 20B. The 'T' bar 168 is first secured to the tissue 52 of the diaphragm crus. The needle 164 is then passed through the tissue of the inner abdominal wall 42, through the loop 170 and then through the abdominal wall 42 to the exterior of the abdomen. Pulling the needle 164 on the exterior of the abdomen pulls the cord 160 tight across the internal organ to move and hold the internal organ in substantially the same manner as that of previously-described embodiments of the apparatus.

[0123] Figures 21A and 21 B show a further embodiment of the apparatus that is substantially the same as that of the embodiment of Figures 20A and 20B, except that the needle 164 is removed from the end of the length of cord 160, leaving a free end 172 of the cord. The method of using this embodiment of the apparatus is substantially the same as that of the previously-described embodiment except for the step of passing the cord free end 172 through the abdominal wall 32. A GraNee needle (not shown) may be used to perform this step of the method.

[0124] Figures 22A and 22B show a further embodiment of the apparatus that is substantially the same as that of the previously-described embodiment, except that it is comprised of only the length of cord 160 having the circular pledget 162 at one end and a free end 172 of the cord at the opposite end. In the method of using this embodiment of the apparatus, the suture free end 172 is first passed through the inner abdominal wall 42, then through the tissue 52 of the diaphragm crus, and then through and out of the abdominal wall 42. As in the previously-described embodiment, the suture free end 172 can be passed through the tissue of the abdominal wall 42 and the crus 52 using a GraNee needle or other similar

instrument. The length of cord 160 is pulled tight to move and hold the first internal organ relative to the second internal organ in substantially the same manner as previously-described method embodiments of the apparatus.

[0125] Figure 23 shows a further embodiment of the apparatus that is substantially the same as that of earlier-described embodiments except for the first and second tissue connectors being "J" hook locking clasps 174, 176 that incorporate one-way clutch mechanisms. The ends of the cord segments 14, 22 can be pulled through the clutch mechanisms of the clasps 174, 176 in one direction, but are prevented by the clutch mechanisms from being pulled through the clasps 174, 176 in the opposite directions.

[0126] Figure 24A-24C show representations of a "J" hook locking clasp such as that shown in Figure 23, with a one-way clutch mechanism. The one-way clutch mechanism is comprised of a rotatable pulley 178 and a "V" shaped groove 180 positioned adjacent the pulley 178. An end portion of the cord 182 is threaded through the "V" shaped groove 180 and then around the pulley 178. When the end of the cord 182 extending from the pulley 178 is pulled tight, the relative positions of the pulley 178 and the groove 180 cause the portion of the cord 182 to wedge and become locked in the bottom of the groove 180.

[0127] Figure 25 shows a further representation of the embodiment of the apparatus employing a "J" hook locking clasp 184 with a one-way clutch mechanism. The one-way clutch mechanism is comprised of a pair of pivoting cams 186, 188 having opposing ratchet tooth surfaces 190, 192. A portion of the apparatus cord 194 is threaded between the opposed tooth surfaces. The portion of cord 194 can be pulled through the spacing between the cam ratchet tooth

surfaces 190, 192 in one direction, for example to the left in Figure 25, but the cams 186, 188 pivot toward each other and their ratchet tooth surfaces 190, 192 clamp the cord portion 194 between the surfaces when the cord portion is pulled in the opposite direction, for example to the right as shown in Figure 25.

[0128] Figure 26 shows a representation of a further embodiment of the "J" hook clasp 196 having a one-way clutch mechanism. In this embodiment, the one-way clutch mechanism is comprised of a toothed wheel 198 that engages with the cord portion 20 pulled through the claps 196. The tooth wheel 198 also has a smaller ratchet wheel 202 at its center. The ratchet wheel 202 engages against a resilient pawl 204. The ratchet wheel 202 and resilient pawl 204 function in the conventional manner allowing the toothed wheel 198 to rotate in one direction when the cord portion 200 is pulled through the clutch mechanism, for example to the right as shown in Figure 26, but prevent the rotation of the toothed wheel 198 and the movement of the cord portion 200 when the cord portion is pulled in the opposite direction, for example to the left as shown in Figure 26.

[0129] Figures 27-32 show several different representations of the possible constructions of the cord segments 14, 22, 38 of the apparatus of the invention. In Figures 27-32 the first and second tissue connectors are represented by needles, for example keith needles 80, 82. The third tissue connector is represented by a 'T' bar 84. It should be understood that these are only examples of only three tissue connectors that could possibly be used with the apparatus of the invention, and that other forms of tissue connectors, for example the types described herein could be used as the three tissue connectors on the apparatus.

[0130] Figure 27 shows the first 14, second 22 and third 38 cord segments as being constructed of suture material.

[0131] Figure 28 shows the first 14 and second 22 cord segments being part of a single length of surgical tape or strap, and the third cord segment 38 being constructed of suture.

[0132] Figure 29 shows the first 14 and second 22 cord segments being constructed of lengths of suture inserted through lengths of surgical tubing. The third cord segment 38 is constructed of suture.

[0133] Figure 30 shows the apparatus as having first 14 and second 22 cord segments constructed of combinations of surgical tape and suture connected end to end. The third cord segment 38 is constructed of suture material.

[0134] Figure 31 shows the apparatus being constructed of first 14 and second 22 cord segments formed from a single length of suture material inserted through a single length of surgical tubing. The third cord segment 38 is constructed of suture material.

[0135] Figure 32 shows the apparatus as having the first 14 and second 22 cord segments constructed of a single continuous length of surgical tape having lengths of suture at opposite ends. The third cord segment 38 is constructed of suture material.

[0136] Figures 33-45 show examples of some of the various different types of tissue connectors that could be used as anyone of the tissues connectors 32, 34, 36 of the apparatus. These are only some of the possible types of tissue connectors, and the connectors shown in Figures 33-45 should not be interpreted as limiting the apparatus to the particular tissue connectors shown..

[0137] Figure 33 shows a 'T' bar 84 as one example of anyone of the three tissue connectors 32, 34, 36.

[0138] Figure 34 shows a barbed needle 114 as anyone of the three tissue connectors 32, 34, 36.

[0139] Figure 35 shows the two-piece rivet pin 126 and cap 130 connector that can be used as anyone of the three tissue connectors 32, 34, 36.

[0140] Figure 36 shows the "j" hook locking clasp 112 that can be used as anyone of the three tissue connectors 32, 34, 36.

[0141] Figure 37 shows the resilient, biased clasp 116 that could be used as any one of the three tissue connectors 32, 34, 36.

[0142] Figure 38 shows a cross-section of an embodiment of a "j" hook locking clasp. The embodiment shown is comprised of a cylindrical housing 206 that contains the "j" hook 208 and a coil spring 210 that biases the "j" hook 208 to its closed position.

[0143] Figures 39A-39C show a variation of the "j" hook locking clasp of Figure 38 where the coil spring 210 is replaced by a spiral band spring 212. Figure 39B shows the spiral and spring 212 in its extended configuration, and Figure 39C shows the spring in its compressed configuration.

[0144] Figures 40A and 40B show a tissue connector clasp that is comprised of a pair of resilient jaws 214, 216 that project from one end of a hollow housing 218, and a pin 220 connected to the jaws that projects from the opposite end of the housing. A spring 22 contained in the housing 218 biases the pin 220 and the jaws 214, 216 to the left as shown in Figure 40A. This causes the resilient jaws to move to their open position shown in Figure 40A. Pulling the pin 220 to the right against

the bias of the spring 222 causes the housing to slide against the opposite sides of the jaws 214, 216 and move the jaws to their closed position.

[0145] Figure 41 shows a side view of the resilient biased clasp 116 described earlier. Compressing the opposite arms 118, 120 of the clasp 116 causes the jaws 122, 124 to separate. Releasing the compression force causes the jaws 122, 124 to move together under the bias of the resilience of the clasp 116.

[0146] Figure 42 shows an embodiment of a clasp comprised of a first jaw 224 and first arm 226 connected by a pivot connection 228 to a second jaw 230 and second arm 232. An oblong cam 234 on a toothed cam wheel 236 is positioned between the pair of arms 226, 232. A toothed actuator wheel 238 meshes with the toothed cam wheel 236. Rotation of the actuator wheel 238 will cause rotation of the cam wheel 236 and the cam 238. Rotation of the cam 234 to its position shown in Figure 42 pushes the pair of arms 226, 232 away from each other which in turn causes the pair of jaws 224,230 to move toward each other. Rotation of the cam 234 90° or one-quarter turn from its position shown in Figure 2 will cause the jaws 242, 230 to move away from each other.

[0147] Figure 43 shows an embodiment of a clasp comprised of a first jaw 240 and first arm 242 connected by a pivot connection 244 to a second jaw 246 and second arm 248. A spring 250 is positioned between the pair of arms 240, 248 and biases the arms away from each other. This in turn biases the first jaw 242 and second jaw 246 toward each other. The jaws 242, 246 are opened by applying a compression force to the opposite sides of the first arm 240 and second arm 248 that compresses the spring 250.

[0148] Figures 44A-44B show a side-sectioned view of a construction of the rivet assembly described earlier. As seen in the drawing figures, the pin head 128 is slightly larger in diameter than the cap hole 132. When the pin 126 is attached to the cap 130, there is a fixed gap or maximum distance between a circular head 252 of the pin 126 and the cap 130.

[0149] Figures 45A-45E show a further embodiment of a rivet assembly. In this assembly, the rivet pin 254 has several notches 256 along its length between the pin head 258 and the pin point 260. The rivet cap 262 is similar in construction to that of the previously-described embodiment with a center opening or hole 264 extending through the cap. However, the cap 262 is also formed with a transverse slot 266 that intersects the center hole 264 and a parallel slot 268 that extends into the cap 262 parallel to the center hole 264 and intersects the transverse slot 266. A locking tab 270 with a pin hole 272 and a spring hole 274 is inserted in the transverse slot 266 for sliding movement therein. A resilient wire spring 276 is inserted downwardly into the parallel slot 268 and through the tab pin hole 272. Inserting the rivet pin 254 into the cap center hole 264 and through the tab pin hole 272 causes the pin to slide the tab 270 to the left as shown in Figure 45A against the bias of the wire spring 276. As a pin notch 256 passes through the tab hole 272, the bias of the spring 276 causes the tab 270 to move to the right and into the notch 256. This locks the pin 254 in place relative to the cap 262. With the pin 254 having a number of notches, and in the example of Figure 45A having three notches, the position of the pin head 258 relative to the cap 262 can be adjusted between three positions. This provides an adjustable gap or an adjustable distance between the pin head 258 and the cap 262.

[0150] Figures 46A-46E represent a further embodiment of the apparatus of the invention. This embodiment is comprised of a length of cord 278 having a needle 280 at one end and a loop 282 formed at the opposite end. A circular pledget 284 is provided on the length of cord 278 toward the loop end of the cord. The apparatus also includes a locking collar having a hollow cylindrical housing 286 that contains a tubular one-way suture lock 288. The suture lock 288 is basically cylindrical but is formed with a resilient tab 290 that projects toward the center of the cylindrical configuration of the suture lock. Figure 46E shows a cross-section representation of the collar cylindrical housing 286 containing the one-way suture lock 288 and a portion of the length of cord 278 extending through the collar. The method of using this embodiment of the apparatus is shown in Figure 46C. In use in the abdominal cavity 46, the needle 280 is first passed through the tissue 52 in the area of the diaphragm crus, and then is passed a first time through the inner abdominal wall 42. The needle 280 is then moved across the inner abdominal wall 42 and is again passed a second time through the inner abdominal wall. The needle is then inserted through the loop 282 and is pulled tight. This causes the length of cord 278 to form a triangular loop in the abdominal cavity that moves the first internal organ away from the second internal organ and holds the first internal organ in the displaced position in the same manner as previously-described methods of using the apparatus of the invention. The needle 280 is then passed through the collar cylindrical housing 286 and the housing 286 is moved tight against the cord loop 282. The cord loop 282 is smaller than the housing 286 so that the housing cannot pass through the loop 282. As the length of cord 278 is pulled through the collar housing 286, the locking tab 290 engages against the side

of the cord 278 as shown in Figure 46E. This allows the cord 278 to move through the collar housing 286 in the direction to the right shown in Figure 46E, but prevents movement of the cord to the left as shown in the figure. In this manner, the apparatus of Figures 46A-46E holds the length of cord tight in its triangular loop configuration.

[0151] Figures 47A and 47B show a further embodiment of the apparatus of the invention and its method of use. The apparatus is comprised of a length of cord 294 having a pledget 296 secured at one end and a needle 298 secured at the opposite end. The apparatus also includes a one-way locking mechanism 300 having a pair of channels 302, 304 through the mechanism dimensioned to receive the length of cord 294. One of the channels 302 allows the length of cord 294 to move through the channel in one direction, but prevents the opposite direction of movement. The other channel 304 allows the length of cord 294 to move through the channel in one direction, but also prevents the opposite direction of movement of the cord 294. As represented in Figure 47A, the method of using the apparatus first involves the needle 298 passing through the inner abdominal wall until the pledget 296 is positioned up against the wall. The needle 298 then passes through the tissue 52 in the area of the diaphragm crus. The needle 298 is then inserted through the first channel 302 of the one-way locking mechanism 300. The needle 298 is then again passed through the inner abdominal wall at a location spaced from the first insertion site and is then passed through the second channel 304 of the one-way locking mechanism 300. The needle 298 with the length of cord 294 are then pulled tight and the locking mechanism 300 is moved up against the inner abdominal wall at the second needle insertion site. This causes the length of cord

294 to move the first internal organ and hold the first internal organ in its moved position away from the second internal organ in a similar manner to that of earlier-described embodiments.

[0152] Figures 47C and 47D show the interior of one embodiment of the one-way locking mechanism 300. The mechanism 300 includes a housing first half 306 and a second half 308 that are connected together by a living hinge 310. The open position of the locking mechanism is shown in Figure 47D. The interior of the two halves 306,308 of the locking mechanism are formed with grooves 312,314 that form the two channels 302,304 through the locking mechanism when the two halves 306, 308 of the locking mechanism are pivoted about the living hinge 310 and snapped together. A "U" shaped spring member 316 is positioned in the first locking mechanism half 306. The spring member 316 has a pair of arms 318,320 that project from opposite sides of the spring member. Each arm 318, 320 in turn has a resilient locking tab 322, 324 that projects outwardly at an angle from its respective arm 318, 320. The resilient tabs 322, 324 are positioned to engage in sliding engagement along portions of the cord 294 that pass through the channels 302, 304. As shown in Figure 47D, the one tab 322 will allow the cord 294 to slide across the tab in a direction from right to left as shown in the drawing figure, but will prevent the reverse sliding movement of the cord. The other tab 324 will allow sliding movement of the cord 294 across the tab 324 in a left to right direction as shown in Figure 47D, but will prevent the reverse movement of the length of cord 294.

[0153] Figures 48A-48D show a variant embodiment of the one-way locking mechanism 300. As shown in Figure 48A, the length of cord is passed through the

locking mechanism 328 in much the same manner as the earlier-described locking mechanism 300. However, the second channel 330 of the locking mechanism 328 of Figure 48A has a block 332 with a hole 334 positioned along the channel. An inclined tooth 336 is positioned in the block hole 334. The portion of the cord length 338 that extends through the locking mechanism channel 330 also extends through the block hole 334. A spring 340 in the locking mechanism 328 biases the block 332 and the tooth 336 toward the portion of cord 338 extending through the locking mechanism channel 330. Due to the inclination of the tooth 336, with the spring 340 biasing the tooth 336 into engagement with the cord portion 338, the cord portion 338 can slide over the tooth 336 as it is moved in a left to right direction as shown in Figure 48C, but is prevented from moving in the opposite direction. Pressing the block 332 into the locking mechanism 328 against the bias of the spring 340 disengages the tooth 336 from the cord portion 338 and permits the cord portion to move in either direction through the locking mechanism 328.

[0154] Figures 49A and 49B show a further embodiment of a cord locking mechanism 344 that is similar to that of Figure 48A. A cross-section of a channel 346 extending through the locking mechanism 344 is shown in Figure 49A. The channel 346 is formed with pairs of ridges 348, 350 on opposite sides of the channel. A wave form spring 352 is positioned in the channel 346. The spring 352 has grooves 354 formed through peaks formed in the wave form spring. The portion of the cord 356 passing through the locking mechanism channel 346 also passes through the grooves 354 in the wave form spring 352. A button hole 358 is provided in the top of the cord locking mechanism 344 and a release button 360 is positioned in the hole. When the release button 360 is pressed in the hole 358, it

engages with the wave form spring 352 and compresses the spring to the position shown in Figure 49A. In this position of the spring 352 the cord 356 is free to move in opposite directions through the locking mechanism 344. When the button 360 is released, the spring 352 moves upwardly from its position shown in Figure 49A and portions of the spring 362 engage with the cord portion 356 extending through the lock mechanism channel 346 and hold the cord portion against the ridges 348 at the top of the channel 346. This locks the cord portion 356 in the locking mechanism 344.

[0155] Figures 50A and 50B show a further embodiment of a one-way cord locking mechanism. The mechanism includes a housing 364 having a hole 366 extending through the housing that is defined by a cone-shaped interior surface 368. A pair of lock members 370,372 are positioned in the housing hole 366. Each of the lock members 370, 372 have exterior surfaces 374,376 that when the locking members are positioned together, define a truncated cone shape that fits within the coneshaped interior surface 368 of the housing 364. The opposing interior surfaces 378, 380 of the lock members 370, 372 are formed with mating peaks and valleys. As shown in Figure 50B, a spring 382 biases the two lock members 370, 372 into the cone-shaped interior surface 368 of the housing 364, thereby causing the lock member interior surfaces 378, 380 to move toward each other. A portion of a cord length 384 extending through the opposing interior surfaces 378, 380 of the lock members 370, 372 is prevented from moving in the upward direction as shown in Figure 50B due to the bias of the spring 382. However, when the cord portion 384 is moved in the opposite downward direction as shown in Figure 50B, the movement of the cord portion 384 causes the lock

members 370, 372 to compress the spring 382. This allows the lock member interior surfaces 378, 380 to move away from each other and release the portion of the cord 384 for movement through the lock mechanism.

[0156] Figures 51A-51E show one method of inserting the apparatus of the invention into the tubular insertion device 86 described earlier. As shown in these drawing figures, a length of suture 386 is looped around the apparatus and is then pulled through the interior of the insertion device 86. The first 14 and second 22 cord segments are folded flat against each other and the additional cord segment 38 is folded over parallel with the first cord segment 14 and second cord segment 22. The apparatus is then pulled by the suture loop 386 into the interior of the insertion device 86 to the position shown in Figure 51E.

[0157] Figures 52A and 52B show a further embodiment of an insertion device 390. The insertion device 390 has the configuration of an elongate narrow rod with a pair of opposed grooves 392, 394 extending up one side of the rod from a distal end 396 of the rod. A third groove 398 is formed in a side of the rod toward a proximal end of the rod. The third groove 398 is positioned between the opposed pair of grooves 392, 394. According to the method of using the insertion device 390, the first cord segment 14 and second cord segment 22 of the apparatus 12 are positioned in the opposed pair of grooves 392, 394 that extend from the insertion device distal end 396. The additional cord segment 38 of the apparatus 12 is positioned in the third groove 398 in the side of the rod. With the cords of the apparatus held in these grooves, the insertion device 390 is then inserted through a cannula 44 to insert the apparatus 12 into the abdominal cavity.

[0158] Figure 53 shows a representation of a further embodiment of the insertion device 402 that is similar in construction to the previously-described embodiment of the insertion device 390. The insertion device 402 of Figure 53 is also comprised of a pair of opposed grooves 404, 406 that receive the first 14 and second 22 cord segments of the apparatus 12, and a third groove 408 that receives the additional cord segment 38 of the apparatus.

[0159] Figure 54 shows a still further embodiment of an insertion device 410. The insertion device 410 has a rod-shaped length with a hollow distal end. The rod distal end is comprised of a first half 412 and a second half 414 that are connected together by a living hinge assembly 416. According to the method of using the insertion device 410 of Figure 54, the apparatus 12 is positioned in the interior of the first half 412 with the first cord segment 14 and second cord segment 22 extending parallel to each other, and the third cord segment 38 folded over the first cord segment 14 and second cord segment 22. The second half 414 of the insertion device is then folded over the hinge assembly 416 and snapped closed to prepare the insertion device 410 for insertion of the apparatus 12.

[0160] Figures 55A-55C show a mesh apparatus 420 that is designed to be used as a part of the apparatus of the invention. The mesh apparatus 420 is basically comprised of a generally rectangular or trapezoidal-shaped panel of surgical mesh 422 with a pair of axially aligned tubes 424 at one side and a pair of axially aligned tubes 426 at the opposite side. As shown in Figure 55B, the mesh apparatus 420 can be rolled up around the pairs of tubes 424, 426 to reduce the size of the apparatus for insertion through a cannula and into the abdominal cavity. Figure 55C shows the mesh apparatus 420 positioned in the abdominal cavity 46

and held in place against the first internal organ 48 by one of the previously-described embodiments of the apparatus. It should be understood that any of the previously described embodiments of the apparatus may be employed according to the method of the invention to hold the surgical mesh 420 in its position as shown in Figure 55C.

[0161] Figures 56A-56C, 57A-57C, 58A-58C and 59A-59C show an embodiment of the apparatus of the invention 500 that employs a surgical tissue connector with a releasable one-way cord lock. The apparatus 500 is basically designed to be attached between body tissue (or the first internal organ) and the abdomen wall with a cord of the apparatus extending across the first internal organ as in previously described embodiments, but also includes a feature for shortening the portion of the cord extending across the first internal organ to thereby cause the portion of the cord to move the first internal organ away from the second internal organ and to hold the first internal organ in the displaced position. Thus, the apparatus 500 enables the use of only one cord to move the first internal organ to a position away from the second internal organ and then hold the first internal organ at the position.

[0162] The apparatus 500 is comprised of a base 502 having a tubular configuration. More specifically the base 502 is formed as a cylindrical housing wall having a hollow interior bore extending entirely through the length of the base housing. A center axis 506 of the interior bore defines mutually perpendicular axially and radial directions relative to the base. The base cylindrical housing 502 has axially opposite first 508 and second 510 ends.

[0163] A first rod 512 and a second rod 514 are secured to the base. As shown in the drawing figures, the first rod 512 extends radially across the base interior bore adjacent the base second end 508. Opposite ends of the first rod 512 are secured to the base cylindrical housing 502. The second rod 514 extends radially across the base interior bore adjacent the base second end 510. Opposite ends of the second rod are secured to the base cylindrical housing 502.

[0164] A first tissue connector 516 extends from the base 502 at the base first end 508. In the example shown in the drawings, the tissue connector 516 has a hook 518 formed at one end and a ring 520 formed at the opposite end. The first rod 512 extends through the ring 520 and thereby connects the tissue connector 516 to the base 502. The hook 518 is employed in connecting the apparatus 500 to body tissue. The tissue connector shown in the drawing figures is only one example of a known type of tissue connector that could be employed with the apparatus 500. Any other type of known tissue connector could replace the tissue connector 516 shown in the drawing figures. Additionally, the first tissue connector could be an integral extension of the base.

[0165] A flexible cord 522 having a length with opposite first 524 and second 526 ends is attached to the base 502 at the base second end 510. An intermediate portion 528 of the cord is wrapped around the second rod 514 thereby attaching the cord 522 to the base 502. A first portion or first percentage 530 of the cord length extends from the intermediate portion 528 and from the base second end 510 to the cord first end 524. A second portion or second percentage 532 of the cord length extends from the intermediate portion 528 and from the base second end 510 to the cord second end 526.

[0166] The cord intermediate portion 528 is wrapped around the second rod 514 by being tied in a Munter hitch or Italian hitch knot 534 around the second rod 514. In Figure 56C the Munter hitch knot 534 is shown on a first radial side of the second rod 514. When the knot 534 is maintained in this position, the first cord portion 530 can be pulled from the knot 534 increasing the length of the cord first portion 530 (or increasing the first percentage of the overall cord length) while decreasing the length of the cord second portion 532 (or decreasing the second percentage of the overall cord length). The cord second portion 532 is braked by the knot 534 with the knot in the first position shown in Figure 56C and the cord second portion cannot be pulled from the knot to increase its length. In Figure 58C the Munter hitch knot 534 is shown positioned on a second radial side of the second rod 514, which is on an opposite side of the second rod 514 from the first radial side. When the knot 534 is maintained in this position, the second cord position 532 can be pulled from the knot increasing the length of the cord second portion 532 (or increasing the second percentage of the cord overall length) while decreasing the length of the cord first portion 530 (or decreasing the first percentage of the cord overall length). The cord first portion 530 is braked by the knot 534 with the knot in the second position shown in Figure 58C and the cord first portion cannot be pulled from the knot to increase its length. The Munter hitch knot 534 is a continuously sliding knot. When the knot 534 is free to move between its first position on the first radial side of the second rod 514 shown in Figure 56C and its second position on the second radial side of the second rod 514 shown in Figure 58C, pulling on the cord first portion 530 will cause the knot 534 to move to the first radial side of the rod 512 shown in Figure 56C. Further pulling on

the cord first portion 530 will cause the length of the cord first portion to increase, while the length of the cord second portion 532 decreases. The cord intermediate portion 528 wrapped around the second rod 514 in the Munter hitch knot 534 is continuously wrapped around the rod as the cord first portion is pulled. Pulling on the cord second portion 532 will cause the Munter hitch knot 534 to move across the second rod 514 to the second radial side of the rod as shown in Figure 58C. Continuing to pull on the cord second portion 532 will cause the length of the cord second portion 532 to increase while the length of the cord first portion decreases. The cord intermediate portion 528 wrapped around the second rod 514 in the Munter hitch knot 534 is continuously wrapped around the second rod 514 as the cord second portion 532 is pulled.

[0167] A second tissue connector 540 is provided on the cord second end 526. The second tissue connector 540 can be any known type of tissue connector used to attach to body tissue and is therefore shown only schematically in the drawing figures. A percentage of the cord length (the second percentage) extends between the first tissue connector and the second tissue connector. The percentage of the cord length extending between the first and second tissue connectors is intra-abdominally adjustable to increase the percentage of the cord length and to decrease the percentage of the cord length.

[0168] The apparatus 500 also includes a releasable one-way cord lock 542. The lock 542 has a cylindrical exterior surface and engages in sliding engagement with the interior surface of the base cylindrical housing 502. The lock 542 moves in axially reciprocating movements through the base interior bore between a first position of the lock shown in Figure 56C and a second position of the lock shown

in Figure 58C. A half cylinder protrusion 544 is formed on the end of the lock adjacent the Munter hitch knot 534. As seen in the drawing Figures, the protrusion 544 is positioned on the second radial side of the second rod 514. Axial slots 546 are formed in the opposite sides of the base cylindrical housing 502 and a pin 548 extends radially through the lock 542 with opposite ends of the pin engaging in sliding engagement in the axial slots 546 of the base 502. The ends of the pin 548 extending into the axial slots 546 allow the lock 542 to axially reciprocate through the interior bore of the base but prevent the lock 532 from rotating around the interior bore of the base. This maintains the lock protrusion 544 on the second radial side of the second rod 514.

[0169] An actuator 550 is mounted on the base 502 and is operatively connected to the reversible one-way cord lock 542. The actuator 550 is formed as a cylindrical sleeve that surrounds the base cylindrical housing 502. The opposite ends of the lock pin 548 project beyond the axial slots 546 in the base cylindrical housing 502 and are secured in opposite sides of the actuator 550. This operatively connects the actuator with the lock 542. The actuator 550 is mounted on the cylindrical housing of the base 502 for axially reciprocating movements between first and second positions of the actuator relative to the base. Moving the actuator 550 to its first position relative to the base 502 moves the one-way cord lock 542 to its first position relative to the base shown in Figure 56C. Moving the actuator 550 to its second position relative to the base 502 moves the cord lock 542 to its second position relative to the base shown in Figure 58C.

[0170] A biasing device urges the one-way cord lock 542 to its first position shown in Figure 56C. In the embodiment of the apparatus shown in the drawing

figures the biasing device 552 is a coil spring. As shown in Figure 56C, with the knot 534 positioned on the first radial side of the second rod 514, the spring 552 biases the lock 542 toward the knot 534 until the lock protrusion 544 engages against the cord intermediate portion 528 adjacent the knot 532. In this position of the protrusion 544 the protrusion prevents the knot 534 from moving around the second rod 514 to the second radial side of the rod. With the knot 534 maintained on the first radial side of the second rod 514 by the lock protrusion 534, exerting a pulling force on the cord first portion 530 will increase the length of the cord first portion while decreasing the length of the cord second portion 532. With the knot 534 maintained on the first radial side of the second rod 514 by the lock protrusion 544, exerting a pulling force on the cord second portion 532 will not result in increasing the length of the cord second portion 532 and decreasing the length of the cord first portion 530. The friction of the knot 534 held in the position shown in Figure 56C will resist the cord second portion 532 from being pulled from the base second end 510.

[0171] With the actuator 550 being moved to its second position and in turn the one-way cord lock 542 being moved to its second position shown in Figure 58C, the knot 534 is free to move between the first radial side of the second rod 514 as shown in Figure 56C and the second radial side of the second rod 514 as shown in Figure 58C. With the lock protrusion 544 moved away from the knot, exerting a pulling force on the cord second portion 532 will cause the knot 534 to move from its position on the first radial side of the second rod 514 shown in Figure 56C to its position on the second radial side of the second rod 514 shown in Figure 58C. In this position of the knot, the pulling force exerted on the cord second portion 532

will result in the length of the cord second portion 532 increasing while the length of the cord first portion 530 decreases. When the actuator 550 is released and the spring 552 biases the one-way cord lock 542 back toward its first position, exerting a pulling force on the cord first portion 530 will cause the knot 532 to move from its position on the second radial side of the second rod 514 shown in Figure 58C to its position on the first radial side of the second rod 514 shown in Figure 56C. The biasing force of the spring 552 is not sufficient to hold the knot 534 on the second radial side of the second rod 514. With the knot 534 positioned on the first radial side of the second rod 514 as shown in Figure 56C, again exerting a pulling force on the cord first portion 530 will result in increasing the length of the cord first portion while decreasing the length of the cord second portion 532. Again, the friction of the knot 534 held at the position on the first radial side of the second rod 514 shown in Figure 56C will resist the cord second portion 532 from being pulled from the base housing second end 510.

[0172] Figures 60A-60C, 61A-61C, 62A-62C and 63A-63C show a variant embodiment of the tissue connector apparatus with a releasable one-way cord lock just described. In this further embodiment of the apparatus 554, many of the component parts of the apparatus 554 are the same as those of the previously described apparatus 500. Therefore, these component parts will not be described again. The reference numbers used to identify the component parts in this further embodiment are the same as those used in identifying the component parts of the previous embodiment of the apparatus 500. These component parts include the base cylindrical wall housing 502, the first rod 512, the second rod 514, the first

tissue connector 516, the second tissue connector 540, the cord 552, the Munter hitch knot 534 and the biasing device or coil spring 552.

[0173] The construction of the further embodiment of the apparatus 554 differs from that of the previous embodiment basically in the construction of the releasable one-way cord lock 556. The lock 556 has a lock protrusion 544 that functions in the same manner as the previous embodiment. However, the cylindrical configuration of the lock 556 extends beyond the base cylindrical housing first end 508 to an annular flange or rim 558 on an opposite end of the lock from the protrusion 544. This rim 558 functions as the actuator of the lock 556. The rim 558 surrounds a hollow center bore 560. The bore extends from the rim down into the lock 556 and ends short of the lock protrusion 544. A pair of axially extending slots 562 are formed in the opposite sides of the lock 556 and communicate the interior bore 560 with the exterior of the lock 556. The first rod 512 extends through the pair of slots 562. The engagement of the first rod 512 through the slots 562 enables the lock 556 to reciprocate between its first and second positions relative to the base 502, but prevents the lock 556 from rotating relative to the base. This maintains the protrusion 544 on the second radial side of the second rod 514.

[0174] The first tissue connector 516 is connected to the first rod 512 just as in the previous embodiment. The first tissue connector 515 extends from the first rod 512 to the hook 518 of the connector.

[0175] The biasing device in the form of the coil spring 522 is positioned in the interior bore 560 of the lock 556. The spring 552 is positioned between the first

tissue connector ring 520 and the lock 556 and exerts a biasing force on the lock pushing the lock toward its first position relative to the base 502.

[0176] The releasable one-way cord lock 556 of the apparatus 554 functions in the same manner as the previously described apparatus in maintaining the Munter hitch knot 534 on the first radial side of the second rod 514 when the lock is in its first position relative to the base, and allowing the knot 534 to move to the second side of the second rod 514 when the lock is moved to its second position on the base.

[0177] Both embodiments of the apparatus have the same method of use. Basically, a portion of the cord is attached to body tissue on an opposite side of the abdominal cavity from the abdominal wall, an additional portion of the cord is attached to the abdominal wall positioning a length or percentage of the cord across the first internal organ, and then the length or percentage of the cord extending across the first organ is decreased thereby causing the decreasing percentage of the cord length to engage across and move the first internal organ away from the second internal organ. This is illustrated schematically in Figure 64. As in the previously described embodiments, the apparatus 554 is first manually passed through the abdomen wall 42, for example through an incision or a cannula 44 in the abdomen wall and is positioned in the abdominal cavity 46 in the area of the first 48 and second 50 internal organs. In the example shown, the first internal organ 48 represented is the human liver and the second internal organ 50 represented is the human stomach.

[0178] The second tissue connector 540 of the apparatus 554 is then manually connected to tissue 52 adjacent to the first internal organ 48 and between the first

48 and second 50 internal organs. In the example shown in Figure 65, the tissue 52 is the crus of the diaphragm. Alternatively, the second tissue connector 540 could be connected to the tissue of the first internal organ 48 itself, as shown in Figure 66. The apparatus 554 is then grasped by its actuator 558 and moved toward the abdominal wall 42. This movement causes the actuator 558 and its associated releasable one-way cord lock to move to their second positions. The movement of the lock allows the knot to move to the second side of the second rod 514 when the cord second portion 532 is pulled in tension. The movement of the knot to the second side of the second rod 514 allows the cord second portion 532 to be pulled from the base second end 510 and increase in length (or increase in percentage) as the apparatus 554 is moved toward the abdominal wall 42. When at the abdominal wall, the tissue connector 516 of the apparatus 500/554 is then connected to the inner abdominal wall 42. This positions the cord second portion 532 extending from the second tissue connector 540 across the first internal organ 48 to the first tissue connector 516 attached to the abdominal wall 42.

[0179] The actuator 558 of the apparatus 554 is then released. This results in the spring of the apparatus moving the releasable one-way cord lock to its first position relative to the base 502.

[0180] The cord first portion 530 is then grasped and pulled from the base second end 510. This causes the knot to move to the first side of the second rod 514 and causes the length of the cord first portion 530 to increase (or increase in percentage) while decreasing the length of the cord second portion 532 (or decreasing the percentage of the cord second portion). The decreasing length of the cord second portion 532 is pulled tight across the first internal organ 48.

Continuing the pulling force on the cord first portion 530 continues to decrease the length of the cord second portion 532 causing the cord second portion to move the first internal organ 48 toward the position away from the second internal organ 50. When the first internal organ 58 is in the desired position, the grasping and pulling force on the cord first portion 530 is released. With the pulling force on the cord first portion 530 having moved the knot to the first radial side of the second rod 514, the lock protrusion prevents the knot from moving back to the second radial side of the second rod 514. With the knot maintained on the first radial side of the second rod 514, the length of the cord second portion cannot be increased. Therefore, the cord second portion 532 holds the first internal organ 48 in its position away from the second internal organ 50 as shown in Figure 67.

[0181] When it is desired to remove the apparatus 554 from the abdominal cavity the actuator 558 is again grasped and moved toward its second position on the base 502. This causes the lock to move to its second position and moves the lock protrusion away from the knot. This again allows the knot to move to the second side of the second rod 514 and allows the cord second portion 532 to be pulled from the base second end 510. This in turn allows the first internal organ 48 to return to its original position relative to the second internal organ 50. The increased length of the cord second portion 532 enables the first tissue connector 516 and second tissue connector 540 to be removed from their connections to the body tissue.

[0182] Figure 68 shows a still further embodiment of the apparatus of the invention. The apparatus in Figure 68 comprises a first tissue connector 572, a cord 574 and a second tissue connector 576 that are the same as those of the

previously discussed embodiment of the apparatus. In addition, the apparatus of Figure 68 includes a third tissue connector 578 that is the same as the first tissue connector 572, and a second length of cord 582 that is the same as the first length of cord 574. The apparatus of Figure 68 also includes a fourth tissue connector 584 that is mounted to the portion of the cord 574 extending between the first tissue connector 572 and the second tissue connector 576 for sliding movement of the fourth tissue connector 584 along the length of cord.

[0183] The method of using the apparatus shown in Figure 68 is similar to that of previously described embodiments. The second tissue connector 576 is connected to body tissue adjacent to the first internal organ or to the first internal organ, and then the first tissue connector 572 is moved intra-abdominally toward the abdominal wall and is connected to the abdominal wall. This causes the first cord 574 to extend across the first internal organ. The third tissue connector 578 is then moved intra-abdominally toward the abdominal wall and is connected to the abdominal wall in a position spaced from the first tissue connector 572. This causes the second cord 582 to extend across the first internal organ. Shortening first 574 and second 582 cords causes the cords to engage with and move the first internal organ upwardly and away from the second internal organ in a manner similar to that of previously described embodiments.

[0184] In addition to the above, the fourth tissue connector 584 can be used to laterally displace or move the first internal organ in a sideways direction. This is accomplished by grasping the fourth tissue connector 584 with a surgical grasper and then pushing the first internal organ to one side or the other before securing

the fourth tissue connector 584 to body tissue. This results in the fourth tissue connector 584 holding the first internal organ in its sideways displaced position.

[0185] As various modifications could be made in the constructions of the apparatus and the methods herein described and illustrated without departing from the scope of the invention, it is intended that all matter contained in the foregoing description or shown in the accompanying drawings shall be interpreted as illustrative rather than limiting. Thus, the breadth and scope of the present invention should not be limited by any of the above-described exemplary embodiments, but should be defined only in accordance with the following claims appended hereto and their equivalents.

What is Claimed Is:

1. A surgical tissue connector apparatus for intra-abdominally moving a first internal organ to a position away from a second internal organ and then holding the first internal organ in the position without manual input, the apparatus comprising:

a first tissue connector that is intra-abdominally connectable to body tissue;

a second tissue connector that is intra-abdominally connectable to body tissue;

a flexible cord having a length with opposite first and second ends, the cord being connected to the first tissue connector and the second tissue connector with a portion of the cord length extending between the first tissue connector and the second tissue connector, the portion of the cord length extending between the first tissue connector and the second tissue connector being intra-abdominally adjustable to selectively move the first and second tissue connectors toward each other and allow the first and second tissue connectors to move away from each other.

2. The apparatus of Claim 1, comprising:

the portion of the cord being selectively adjustable while the first and second tissue connectors are connected to body tissue.

3. The apparatus of Claim 1, further comprising:

the portion of the cord being selectively adjustable while the first and second tissue connectors are connected to body tissue on opposite sides of an abdominal cavity.

4. The apparatus of Claim 1, further comprising:

the apparatus being dimensioned for endoscopic insertion into an abdominal cavity for use of the apparatus in moving the first internal organ to the position away from the second internal organ and temporarily holding the first internal organ in the position and removal from the abdominal cavity after use.

5. The apparatus of Claim 1, further comprising:

the portion of the cord extending between the first tissue connector and the second tissue connector being a percentage of the cord length, and the percentage of the cord length extending between the first tissue connector and the second tissue connector being intra-abdominally adjustable to increase the percentage of the cord length extending between the first tissue connector and the second tissue connector and to decrease the percentage of the cord length extending between the first tissue connector and the second tissue connector.

6. The apparatus of Claim 5, further comprising:

the first tissue connector being intra-abdominally connectable to an abdominal wall inside an abdominal cavity and the second tissue connector being intra-abdominally connectable to body tissue on an opposite side of the abdominal cavity from the abdominal wall with the percentage of the cord length extending between the first and second tissue connectors extending across a first internal organ in the abdominal cavity whereby adjustably decreasing the percentage of the cord extending between the first and second tissue connectors results in decreasing a length of a portion of the cord extending between the first and second tissue connectors and thereby causes the portion of the cord to engage across the first internal organ and move the first internal organ to the position away from a second internal organ.

7. The apparatus of Claim 6, further comprising:

the second tissue connector being intra-abdominally connectable to body tissue adjacent the first internal organ.

8. The apparatus of Claim 6, further comprising:

the second tissue connector being intra-abdominally connectable to body tissue of the first internal organ.

9. The apparatus of Claim 5, further comprising:

a third tissue connector that is intra-abdominally connectable to body tissue, the third tissue connector being mounted on the percentage of the cord length extending between the first and second tissue connectors for sliding movement of the third tissue connector along the percentage of the cord length.

10. The apparatus of Claim 5, further comprising:

an intermediate portion of the cord length being attached to the first tissue connector, a first portion of the cord length extending from the cord intermediate portion to the cord first end, and the percentage of the cord length extending between the first tissue connector and the second tissue connector being a second portion of the cord length that extends from the cord intermediate portion to the cord second end and the second tissue connector, whereby pulling the cord first portion from the first tissue connector to increase a length of the cord first portion extending from the cord intermediate portion results in decreasing the percentage of the cord length extending between the first and second tissue connectors and decreasing the length of the cord second portion.

11. The apparatus of Claim 10, further comprising:

a releasable one-way lock attached to the first tissue connector, the lock being moveable between first and second positions of the lock relative to the cord intermediate portion where in the lock first position the lock is operative to allow the cord first portion to be pulled from the cord intermediate portion to thereby increase the length of the cord first portion while decreasing the length of the cord second portion and prevents the cord second portion from being pulled from the cord intermediate portion, and in the lock second position the lock is operative to allow the cord second portion to be pulled from the cord intermediate portion to thereby increase the length of the cord second portion while decreasing the length of the cord first portion.

12. The apparatus of Claim 11, further comprising:

in the lock second position, the lock allows the cord first portion to be pulled from the cord intermediate portion to thereby increase the length of the cord first portion while decreasing the length of the cord second portion.

13. The apparatus of Claim 11, further comprising:

a base attached to the first tissue connectors;

a rod on the base;

the intermediate portion of the cord being attached to the base by being wrapped around the rod with the first portion of the cord extending from the base to the cord first end and the second portion of the cord extending from the base to the cord second end and the second tissue connector; and,

the releasable one-way lock being mounted on the base for movement of the lock between first and second positions of the lock on the base wherein the

lock first position the lock engages with the cord intermediate portion and in the lock second position the lock is disengaged from the cord intermediate portion.

14. The apparatus of Claim 13, further comprising:

a biasing device on the base urging the lock toward the lock first position relative to the base.

15. The apparatus of Claim 13, further comprising:

an actuator mounted on the base for movement of the actuator between first and second positions of the actuator relative to the base;

the actuator being operatively connected to the lock to cause the lock to move to the first and second positions of the lock in response to the actuator being moved to the respective first and second positions of the actuator, and the actuator being positioned on the base where the actuator is accessible to be grasped.

16. The apparatus of Claim 13, further comprising:

the base having a tubular housing wall with a hollow interior bore extending through the housing wall between the base first and second ends; and

the lock being mounted inside the tubular housing wall for reciprocating movement through the interior bore between the lock first and second positions.

17. The apparatus of Claim 13, further comprising:

the cord intermediate portion being wrapped around the rod in a Munter hitch knot.

18. A surgical tissue connector apparatus for intra-abdominally moving a first internal organ to a position away from a second internal organ and then holding

the first internal organ in the position without manual input, the apparatus comprising:

a base having a length with opposite first and second ends;

a tissue connector on the base, the tissue connector extending from the base first end to a device on the tissue connector that is operable to connect the tissue connector to body tissue;

a rod on the base;

a flexible cord having a length with opposite first and second ends, an intermediate portion of the cord length being tied in a Munter hitch knot around the rod, a first portion of the cord extending from the Munter hitch knot on a first side of the rod and from the base second end to the first end of the cord and a second portion of the cord extending from the Munter hitch knot on a second side of the rod opposite the first side of the rod and from the base second end to the second end of the cord, the Munter hitch knot being movable on the rod between the first and second sides of the rod where when the Munter hitch knot is positioned on the first side of the rod the cord first portion can be pulled from the Munter hitch knot and thereby increase the length of the cord first portion and decrease the length of the cord second portion while the cord second portion cannot be pulled from the Munter hitch knot to increase the length of the cord second portion, and when the Munter hitch knot is positioned on the second side of the rod, the cord second portion can be pulled from the Munter hitch knot and thereby increase the length of the cord second portion and decrease the length of the cord first portion while the cord first portion cannot be pulled from the Munter hitch knot to increase the length of the cord first portion; and

a releasable one-way lock mounted on the base for movement of the lock between first and second positions of the lock relative to the base where in the first position the lock keeps the Munter hitch knot on the first side of the rod and prevents the Munter hitch knot from moving from the first side of the rod to the second side of the rod and thereby allows the cord first portion to be pulled from the Munter hitch knot to increase the length of the cord first portion while preventing the cord second portion from being pulled from the Munter hitch knot to increase the length of the cord second portion, and in the second position the lock allows the Munter hitch knot to move from the first side of the rod to the second side of the rod and thereby allows the cord second portion to be pulled from the Munter hitch knot to increase the length of the cord second portion while decreasing the length of the cord first portion

19. The apparatus of Claim 18, further comprising:

in the lock second position the lock allows the Munter hitch knot to move from the first side of the rod to the second side of the rod and allows the Munter hitch knot to move from the second side of the rod to the first side of the rod.

20. The apparatus of Claim 18, further comprising:

in the first position of the lock the lock engages against the Munter hitch knot when the Munter hitch knot is on the first side of the rod and in the second position of the lock the lock disengages from the Munter hitch knot.

21. The apparatus of Claim 18, further comprising:

a biasing device on the base urging the lock toward the first position of the lock relative to the base.

22. The apparatus of Claim 18, further comprising:

an actuator mounted on the base for movement of the actuator between first and second positions of the actuator relative to the base, the actuator being operatively connected to the lock to cause the lock to move between the first and second positions of the lock in response to the actuator being moved between the respective first and second positions of the actuator, and the actuator being positioned on the base where the actuator can be grasped.

23. The apparatus of Claim 18, further comprising:

an additional tissue connector on the cord second end.

24. The apparatus of Claim 18, further comprising:

the base having a cylindrical housing wall with a hollow interior bore extending through the housing wall, the housing wall having a center axis that defines mutually perpendicular axial and radial directions relative to the housing wall, and the releasable one-way lock being mounted on the housing wall inside the interior bore for axially reciprocating movements of the lock relative to the housing wall.

25. A method of intra-abdominally moving a first internal organ to a position away from a second internal organ and then holding the first internal organ at the position without manual input, the method comprising:

providing a cord having a flexible length with opposite first and second ends;
inserting the cord through an abdominal wall and into an abdominal cavity containing the first and second organs;

connecting a first part of the cord to body tissue on an opposite side of the abdominal cavity from the abdominal wall;

connecting a second part of the cord to the abdominal wall with the cord extending across the first internal organ; and

moving the first internal organ to the position away from the second internal organ.

26. The method of Claim 25, further comprising:

decreasing a length of the cord extending across the first internal organ and thereby causing the decreasing length of the cord to engage across the first internal organ and move the first internal organ to the position away from the second internal organ.

27. The method of Claim 25, further comprising:

connecting the first part of the cord to body tissue adjacent the first internal organ.

28. The method of Claim 25, further comprising:

connecting the first part of the cord to body tissue on the first organ.

29. The method of Claim 25, further comprising:

the second part of the cord connected to the abdominal wall being an intermediate portion of the cord length with a first portion of the cord length extending from the cord intermediate portion to the cord first end and a second portion of the cord extending from the cord intermediate portion to the cord second end, the second portion of the cord extending from the cord intermediate portion across the first internal organ to the cord second end; and

shortening a length of the cord second portion and thereby causing the cord second portion to push against and move the first internal organ to the position

away from the second internal organ and then hold the first internal organ at the position without manual input.

30. The method of Claim 29, further comprising:

shortening the length of the cord second portion by exerting a pulling force on the cord first portion causing a length of the cord first portion to increase and in response causing the length of the cord second portion to decrease.

31. The method of Claim 29, further comprising:

providing a tissue connector apparatus having a base with a tissue connector extending from the base and having a releasable one-way lock on the base with the cord intermediate portion extending through the one-way lock on the base, the lock being moveable between first and second positions of the lock relative to the base where in the lock first position the lock engages with the cord intermediate portion and allows the cord first portion to be pulled from the base to thereby increase the length of the cord first portion while decreasing the length of the cord second portion while the lock prevents the cord second portion from being pulled from the base, and in the lock second position, the lock disengages from the cord intermediate portion and allows the cord second portion to be pulled from the base to thereby increase the length of the cord second portion while decreasing the length of the cord first portion.

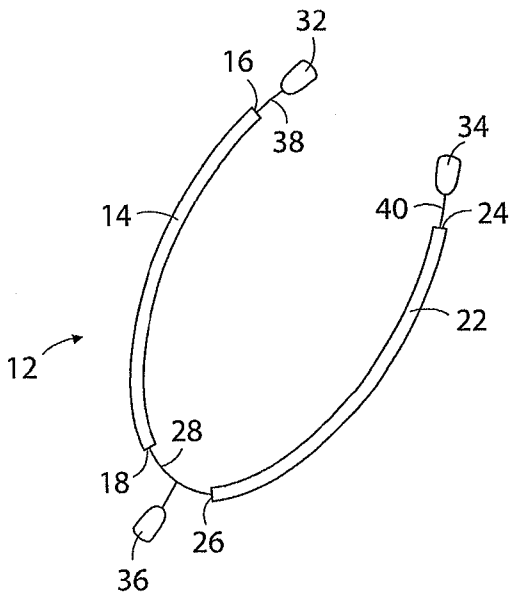


FIG. 1

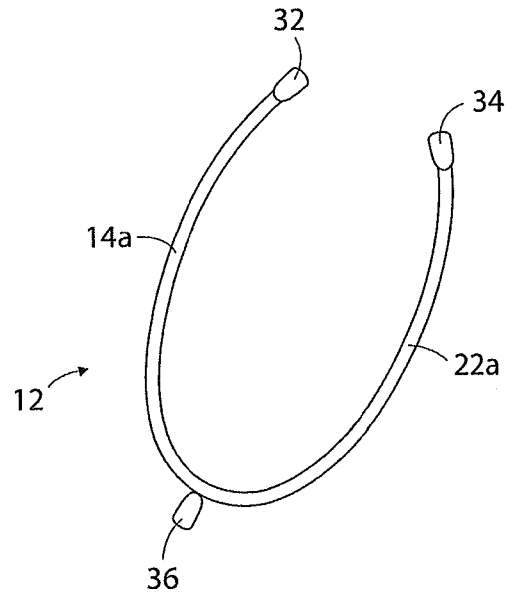


FIG. 2

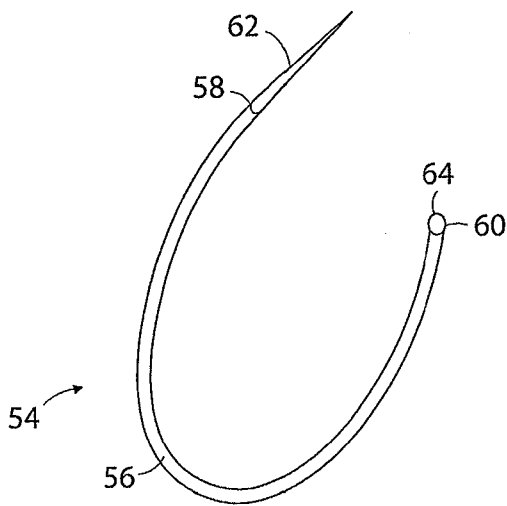


FIG. 3

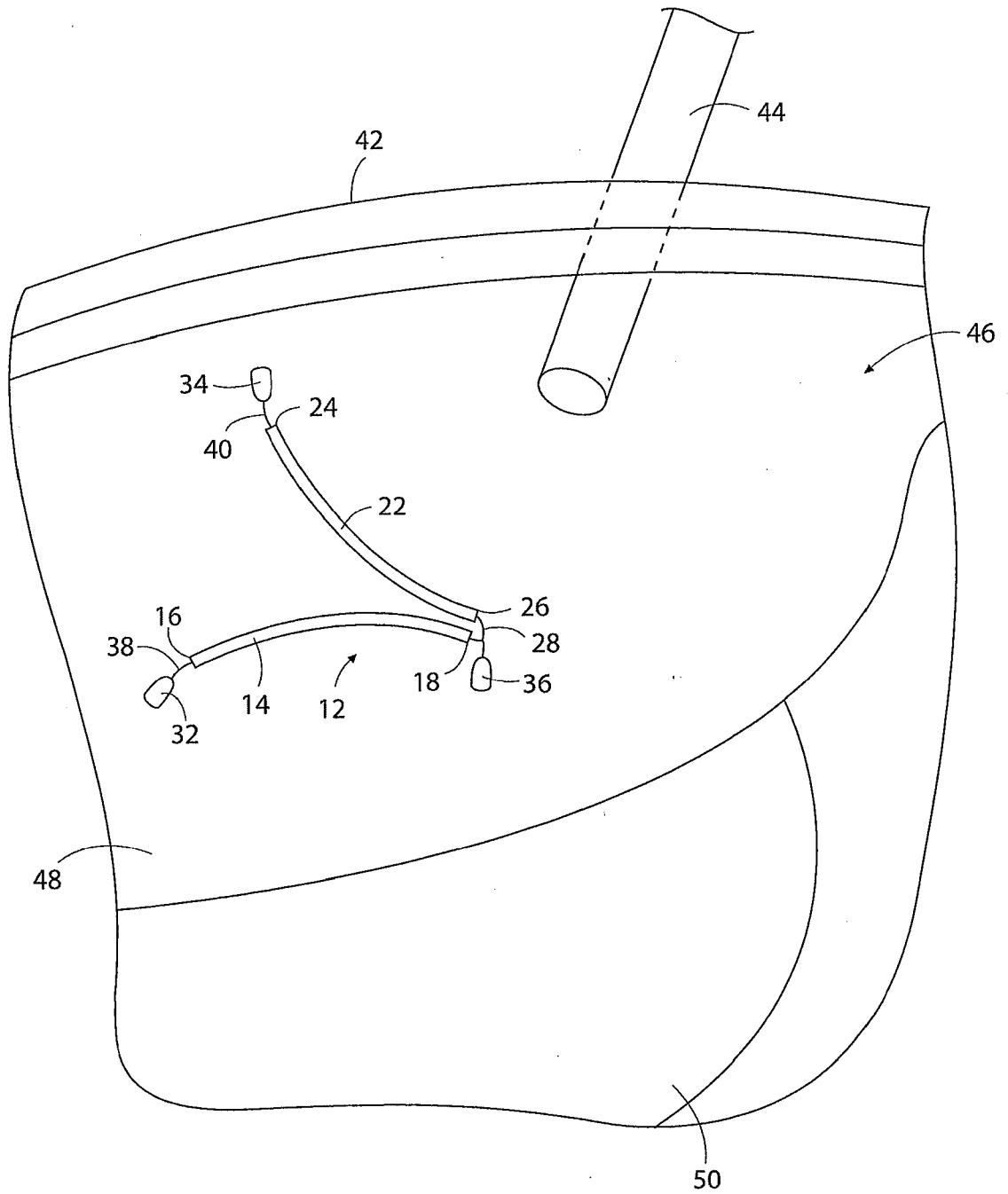


FIG. 4

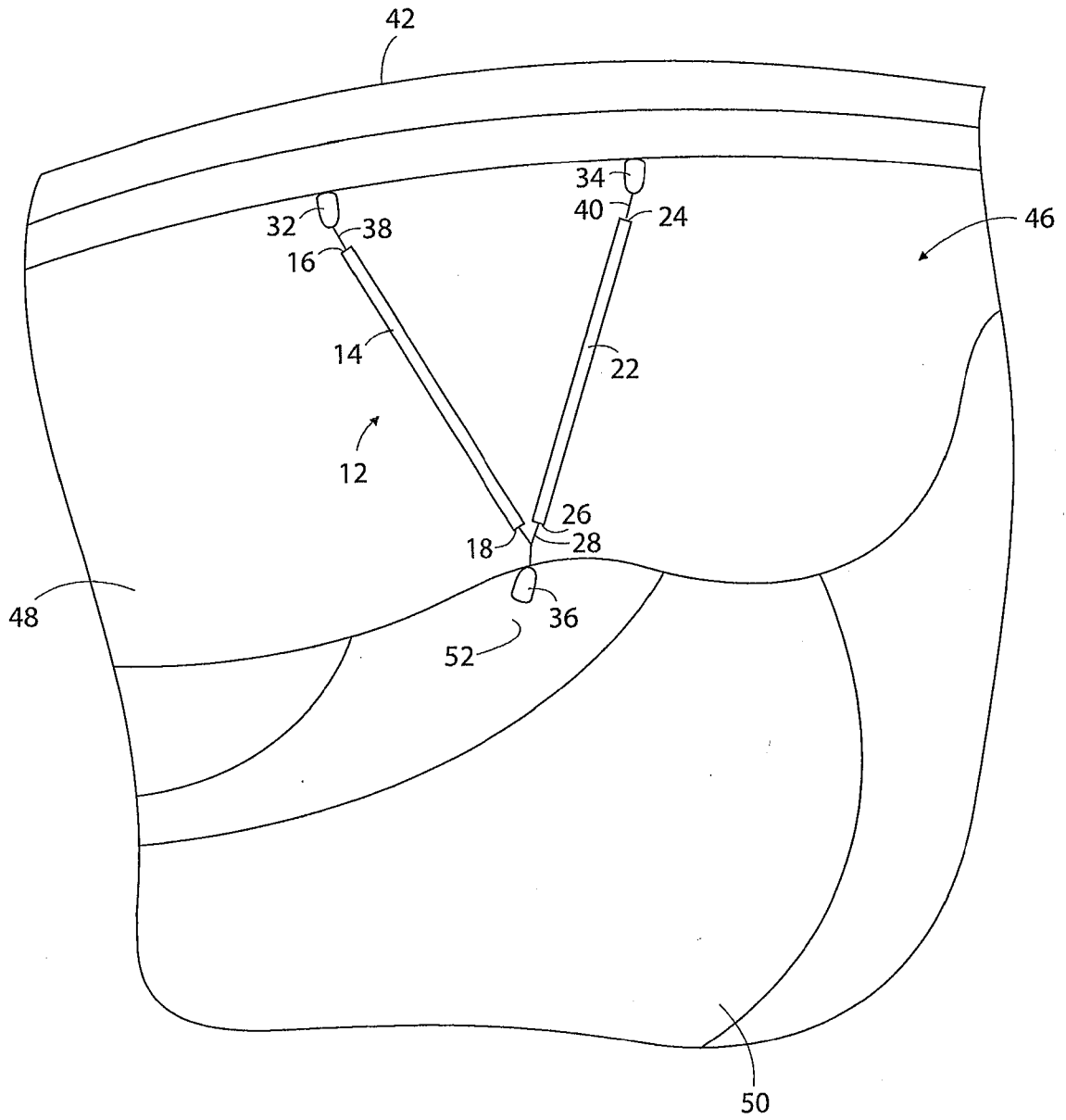


FIG. 5

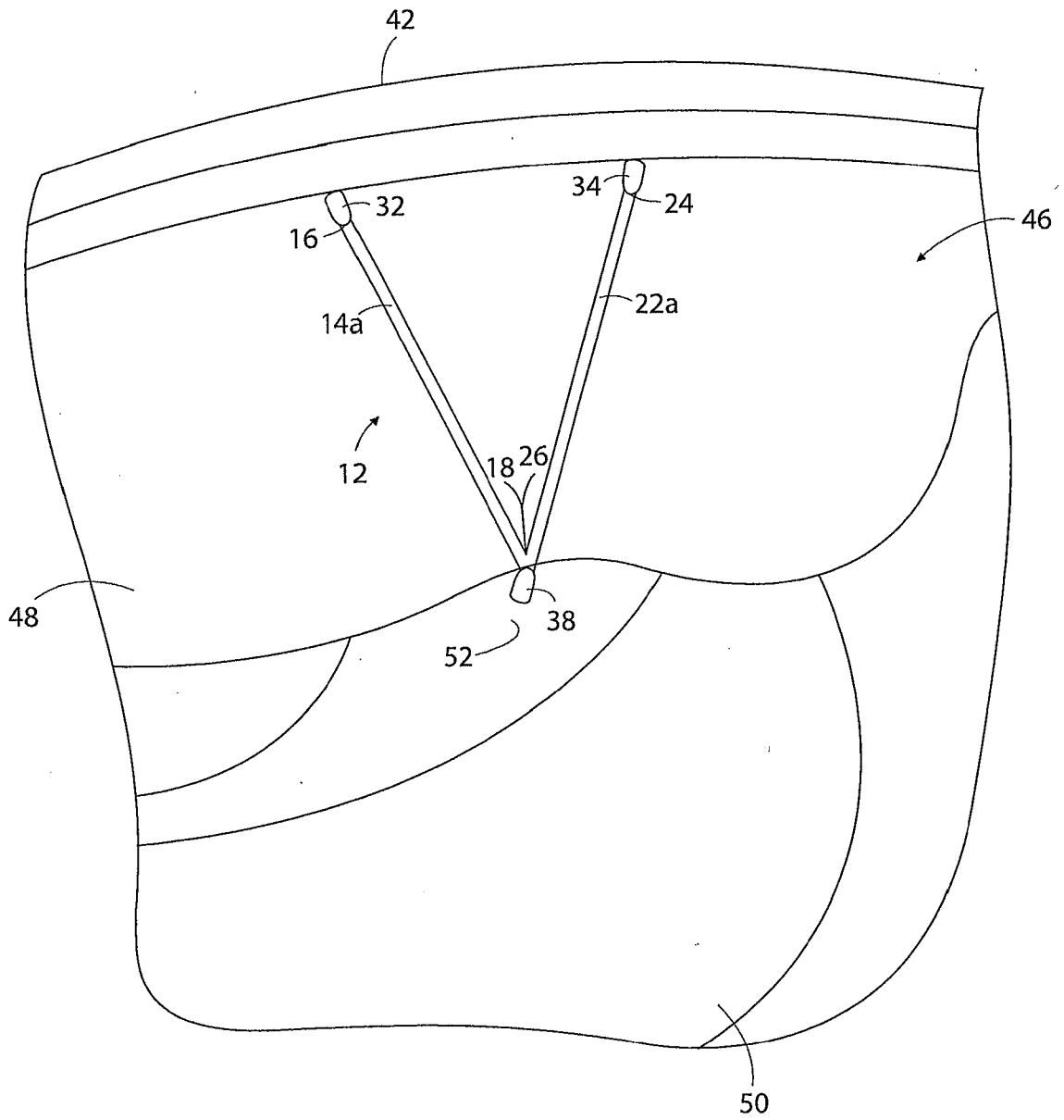


FIG. 6

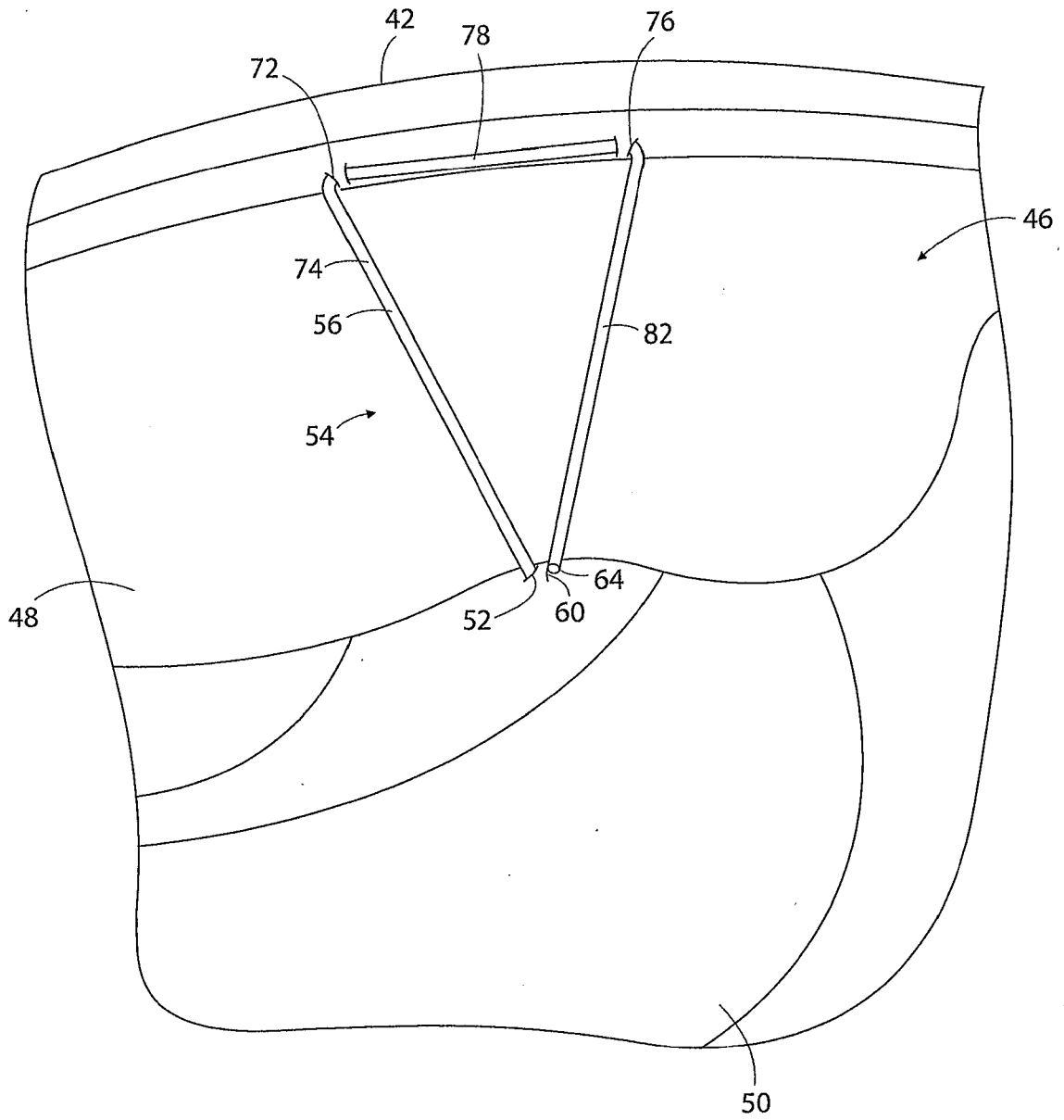


FIG. 7

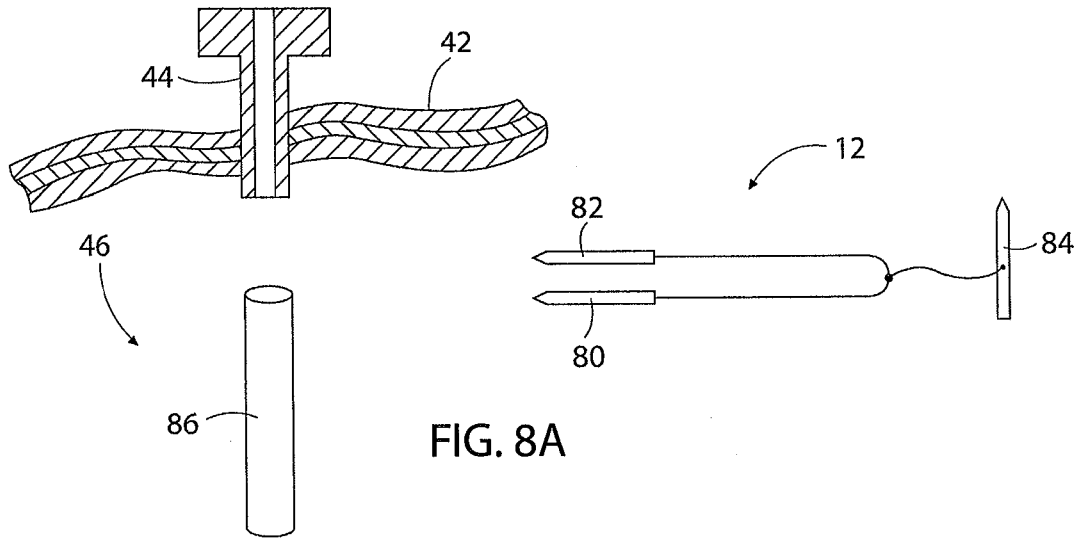


FIG. 8A

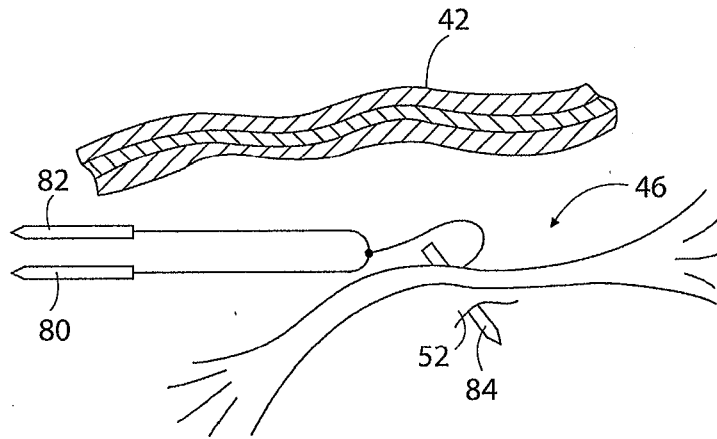


FIG. 8B

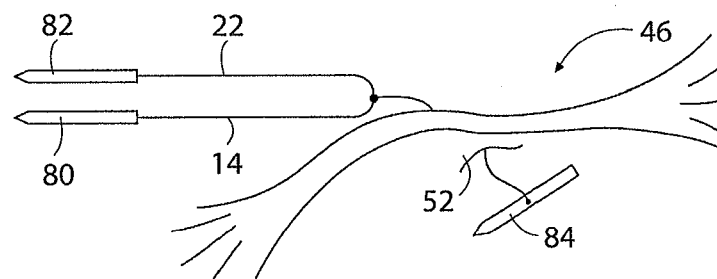


FIG. 8C

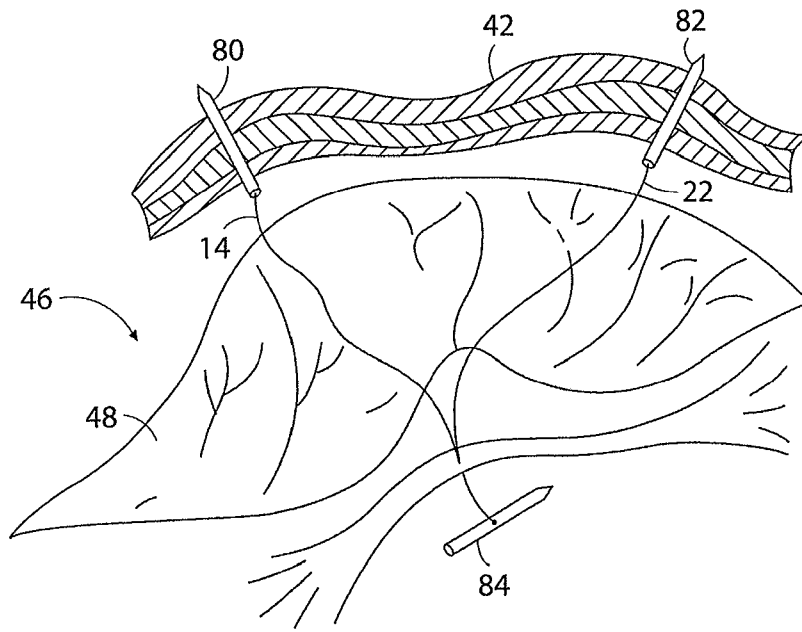


FIG. 8D

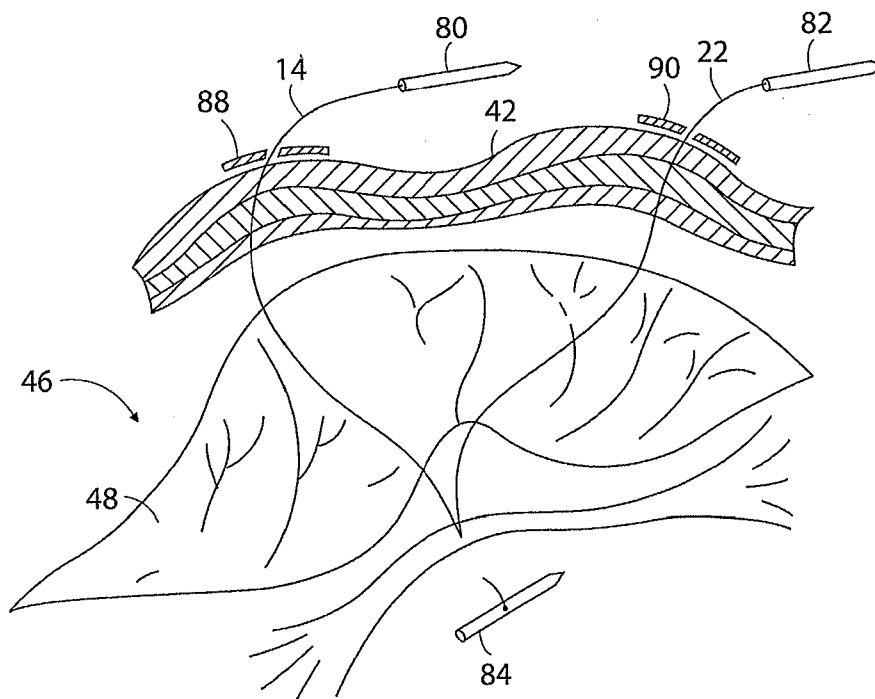


FIG. 8E

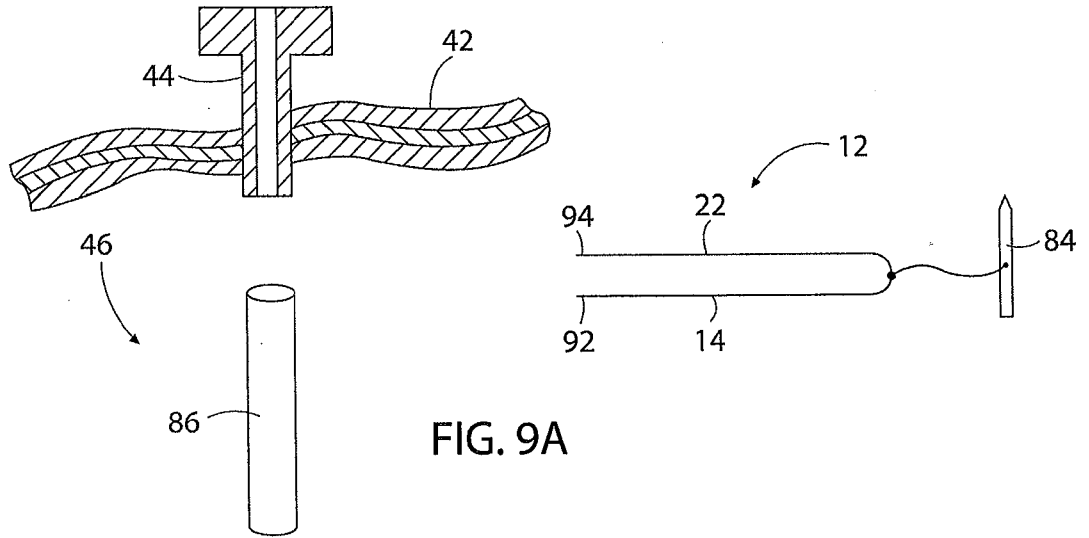


FIG. 9A

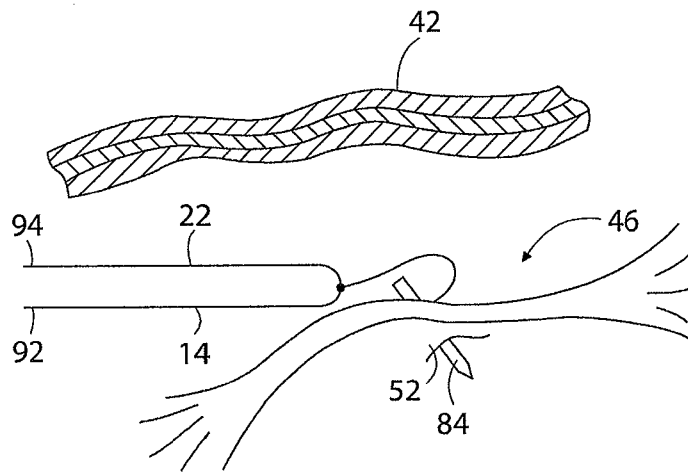


FIG. 9B

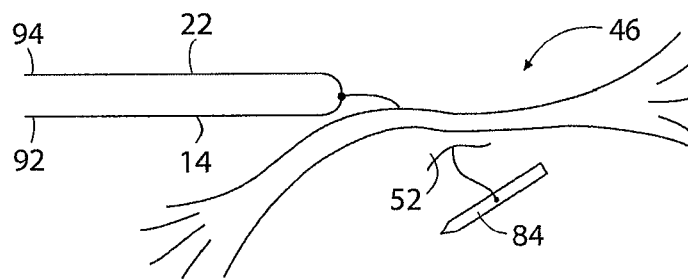


FIG. 9C

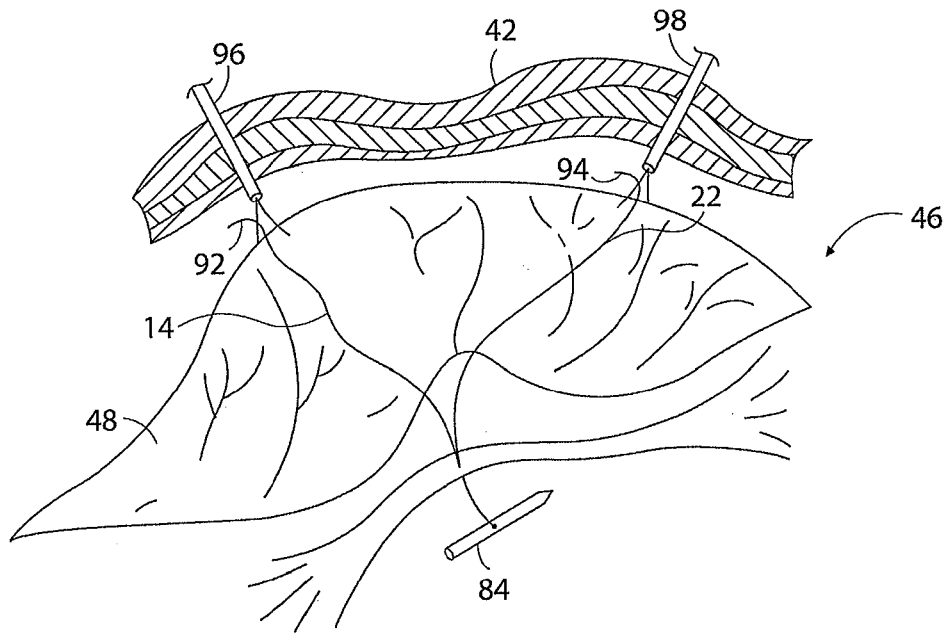


FIG. 9D

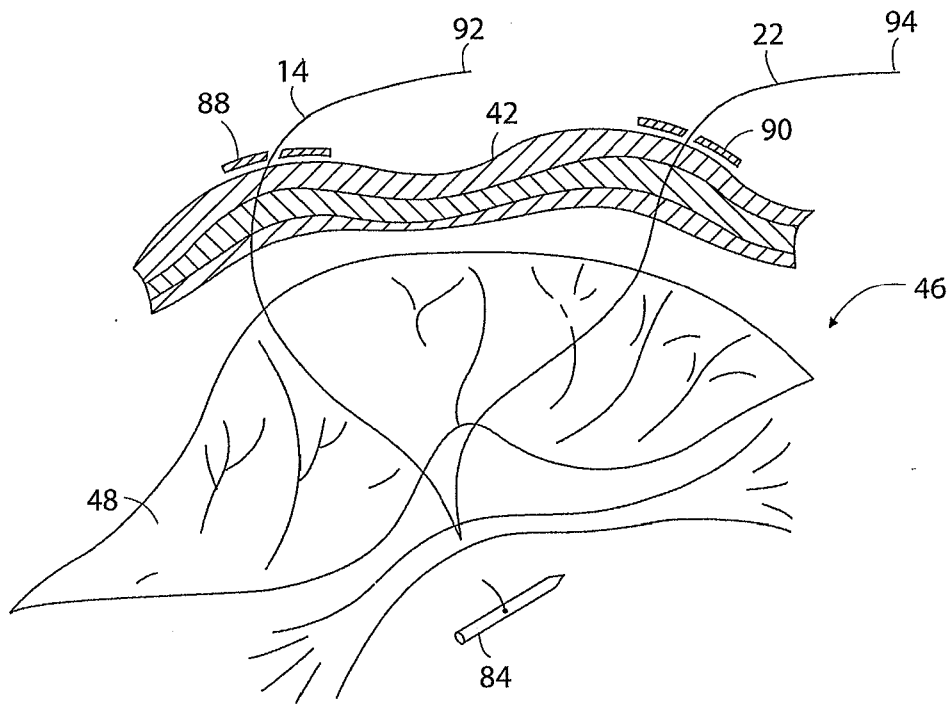


FIG. 9E

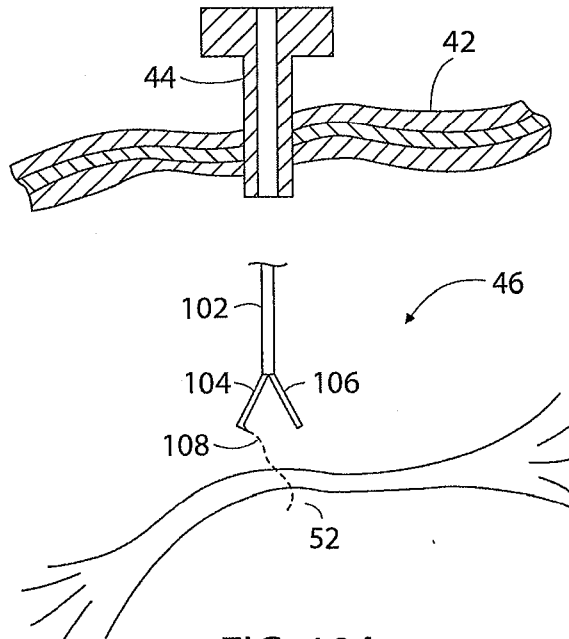


FIG. 10A

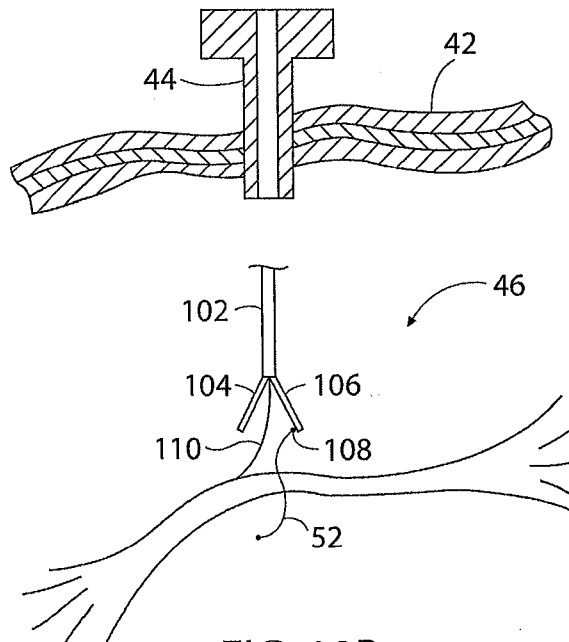


FIG. 10B

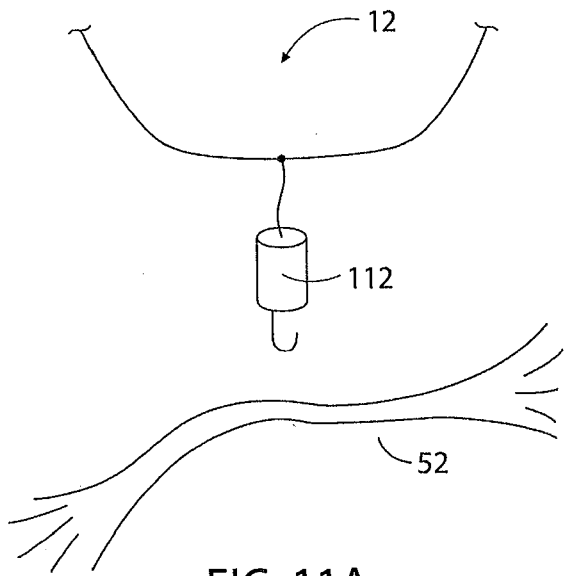


FIG. 11A

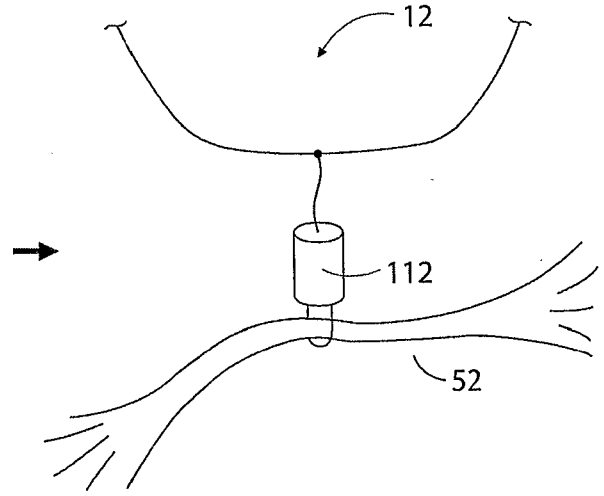


FIG. 11B

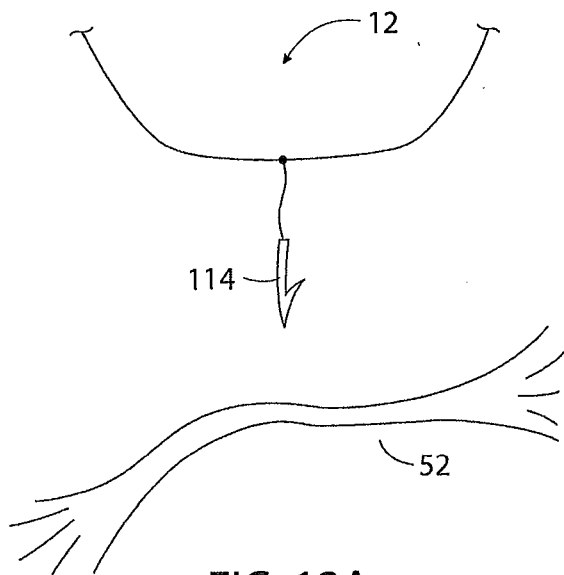


FIG. 12A

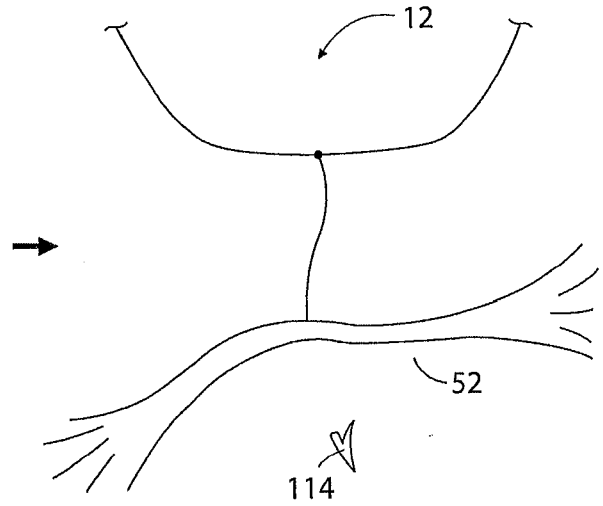


FIG. 12B

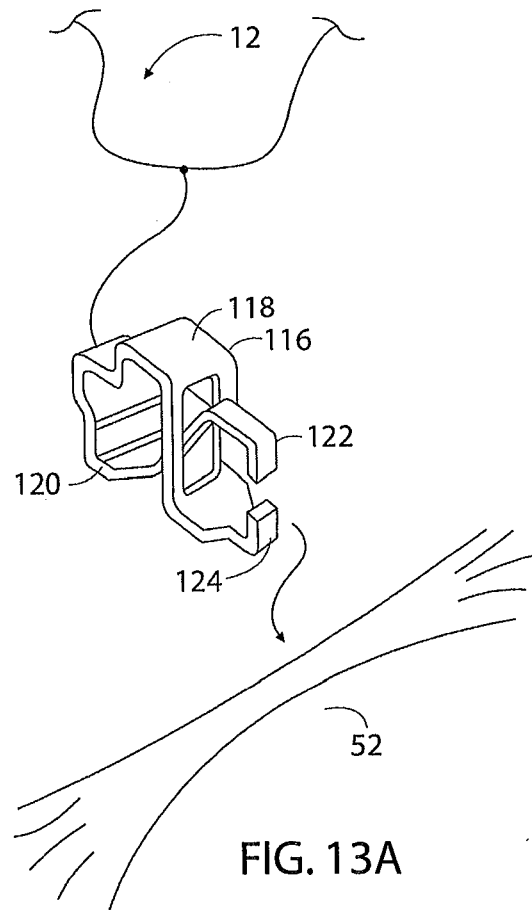


FIG. 13A

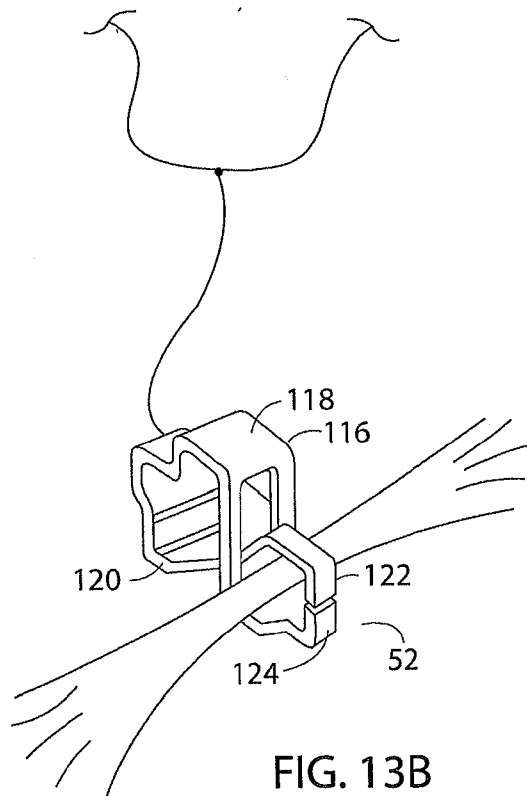
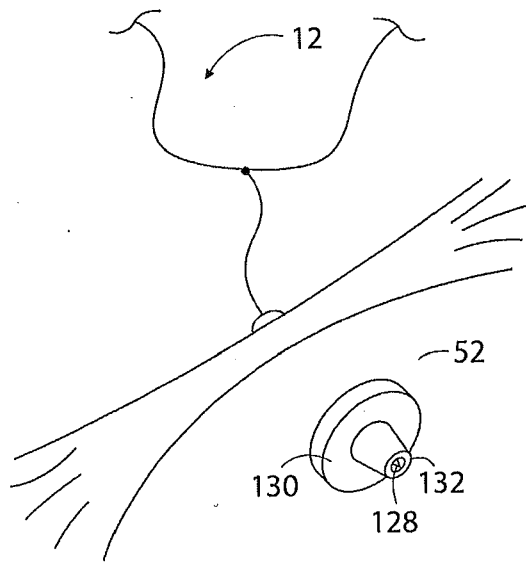
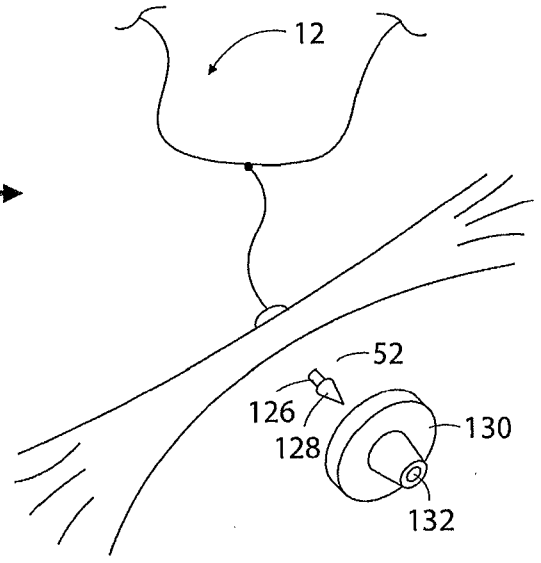
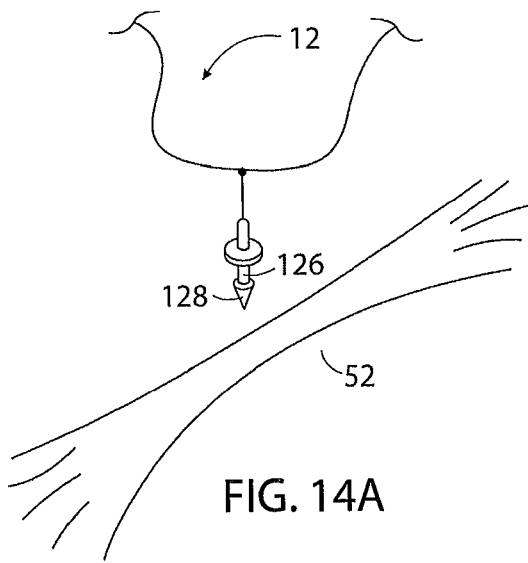


FIG. 13B



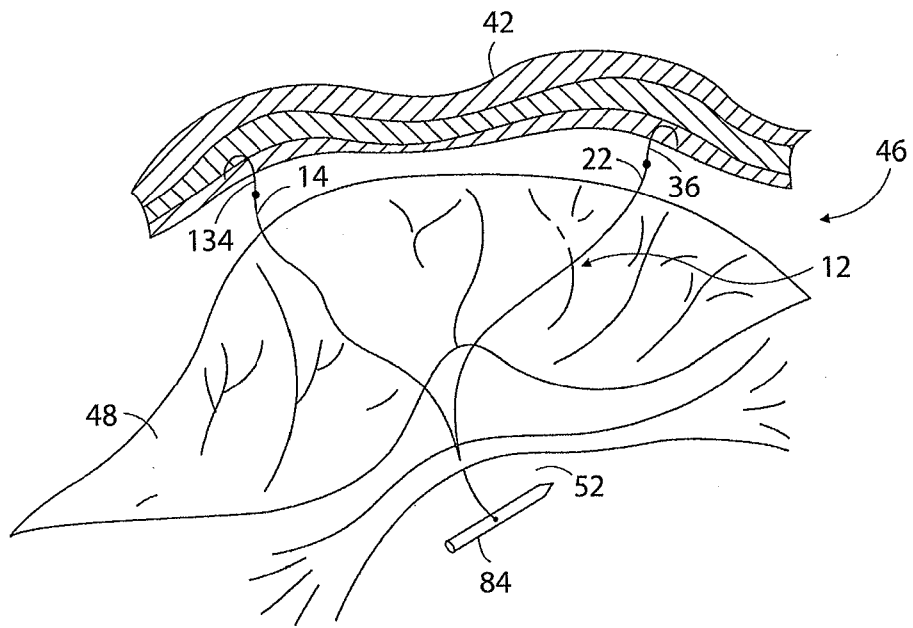


FIG. 15B

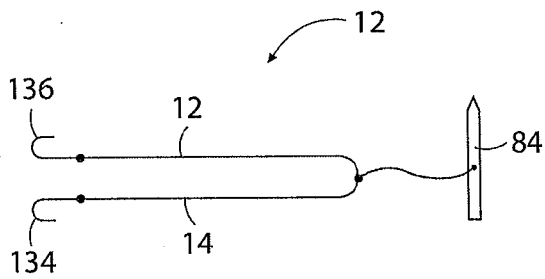


FIG. 15A

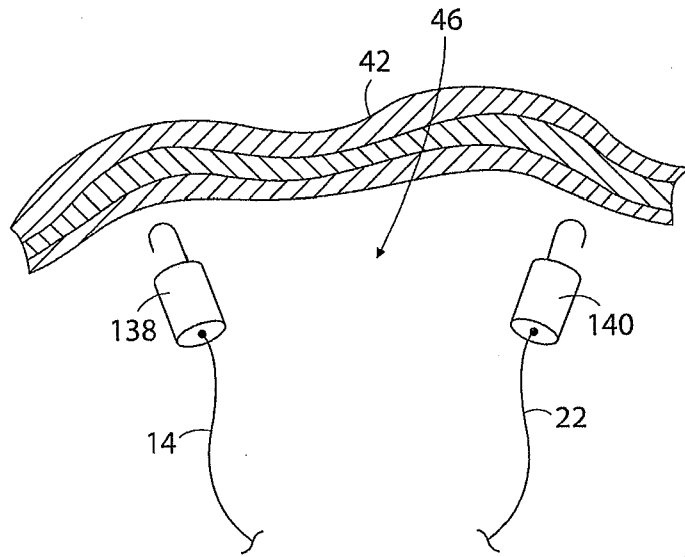


FIG. 16A

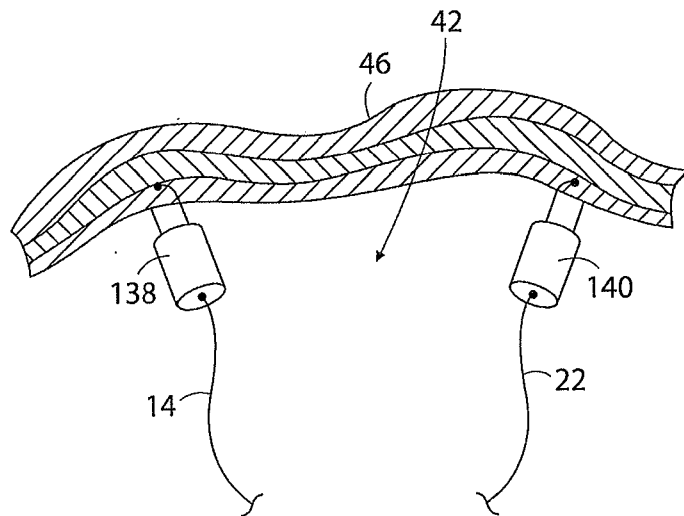


FIG. 16B

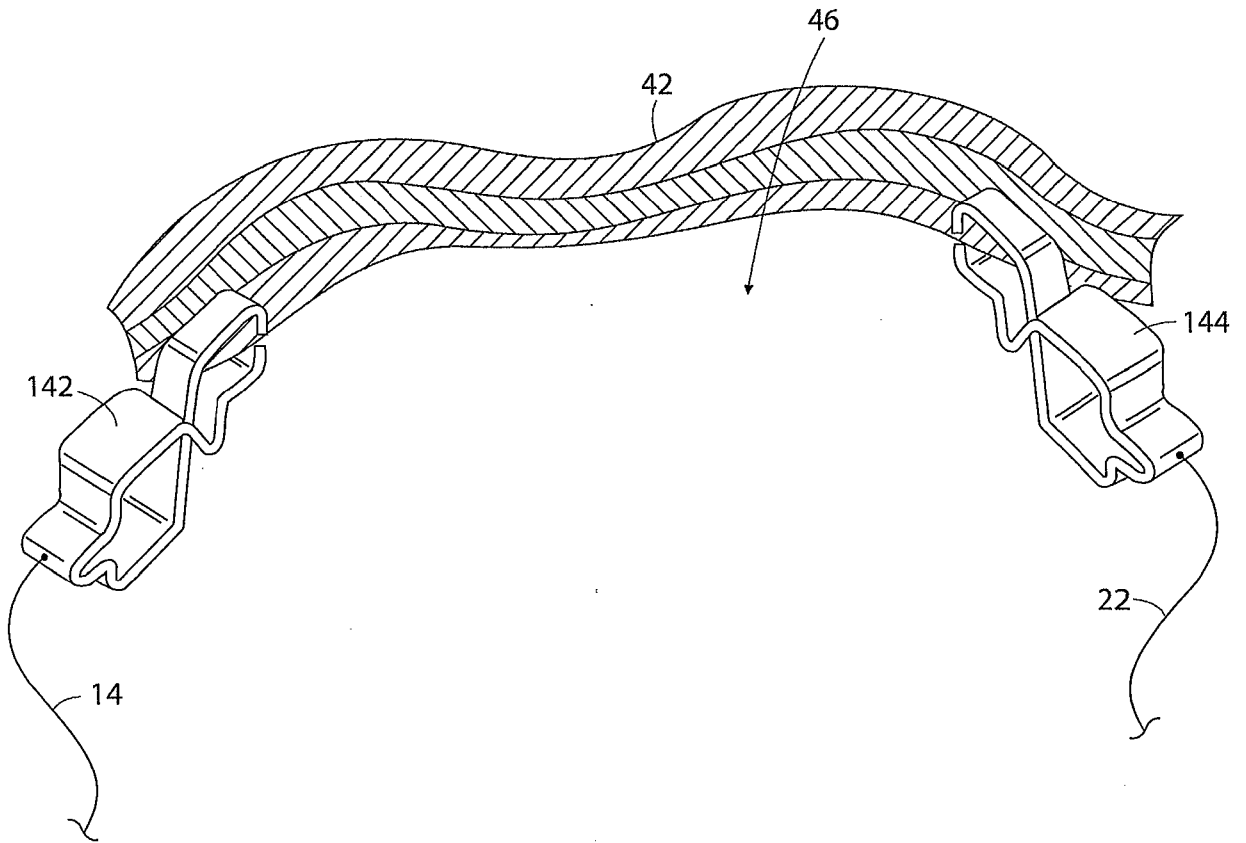


FIG. 17

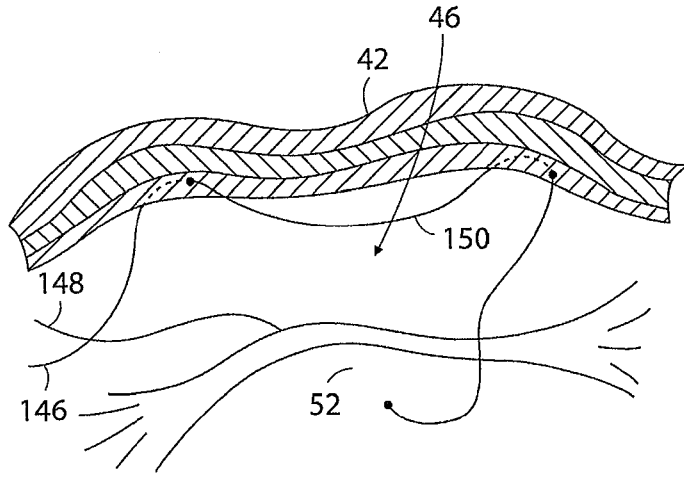


FIG. 18A

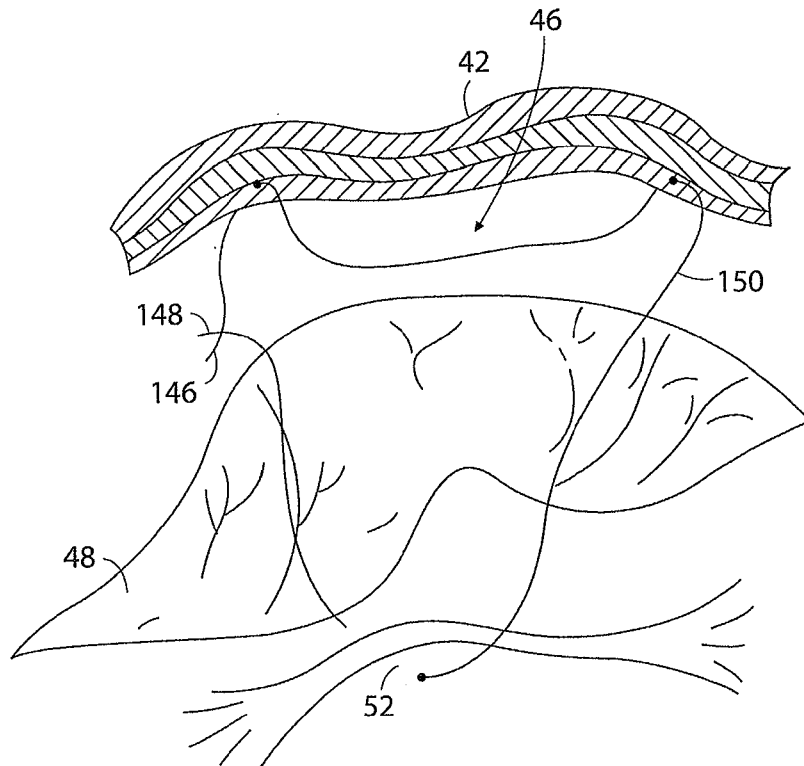


FIG. 18B

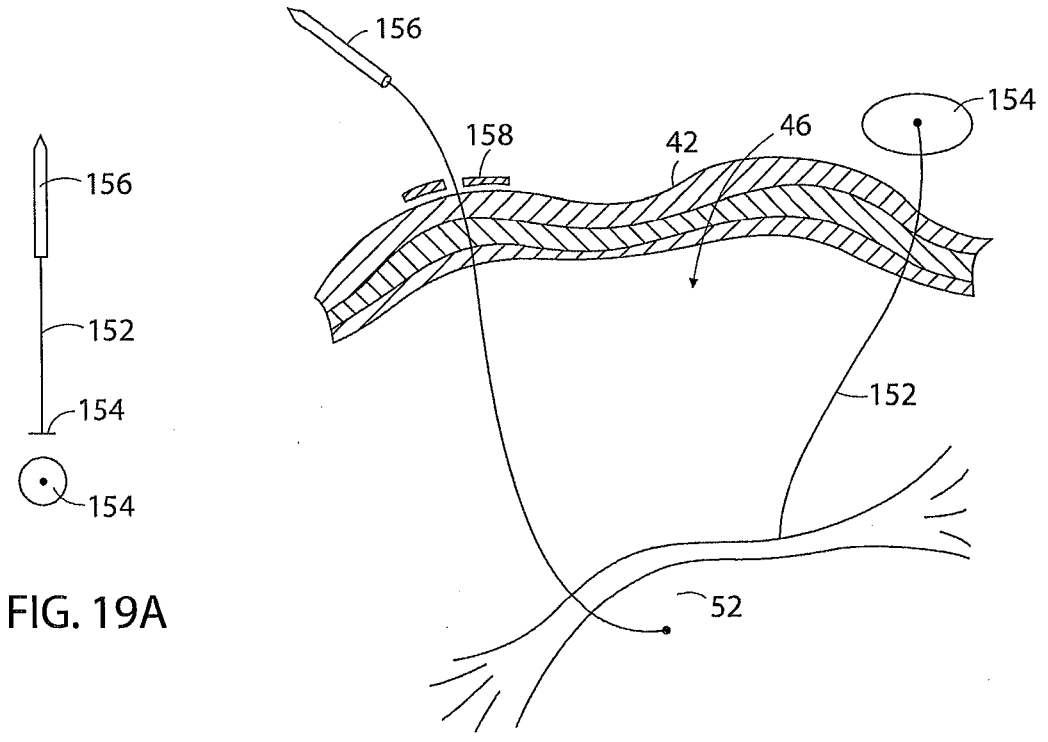


FIG. 19A

FIG. 19B

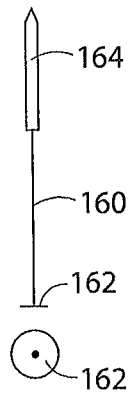


FIG. 20A

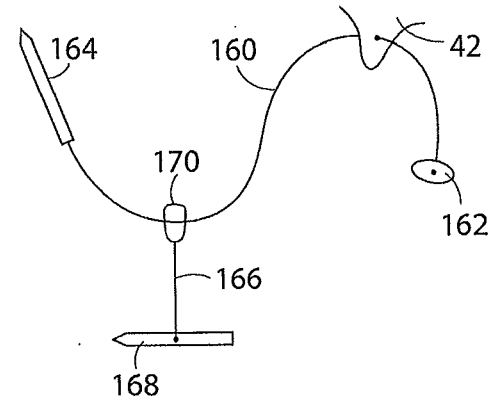
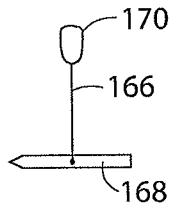


FIG. 21A

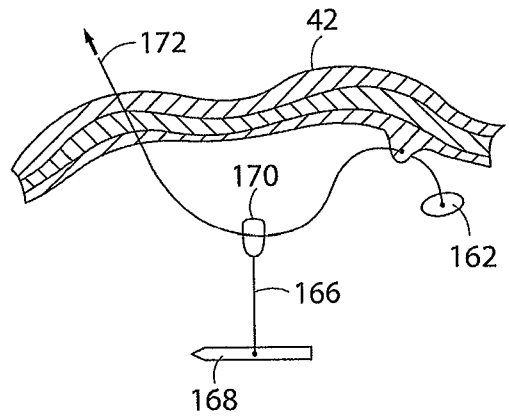


FIG. 21B

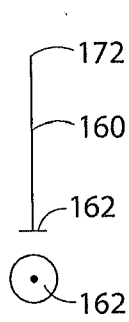


FIG. 22A

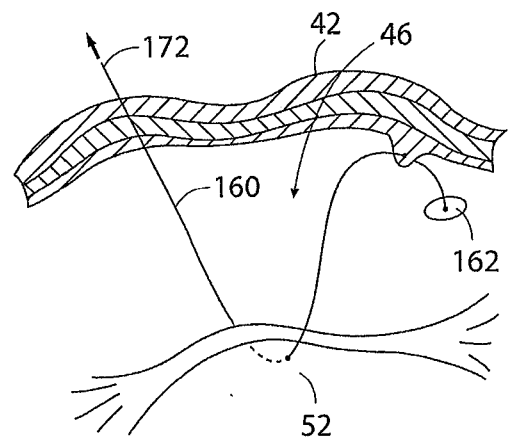
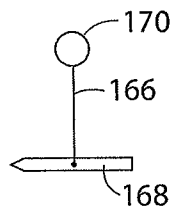


FIG. 22B

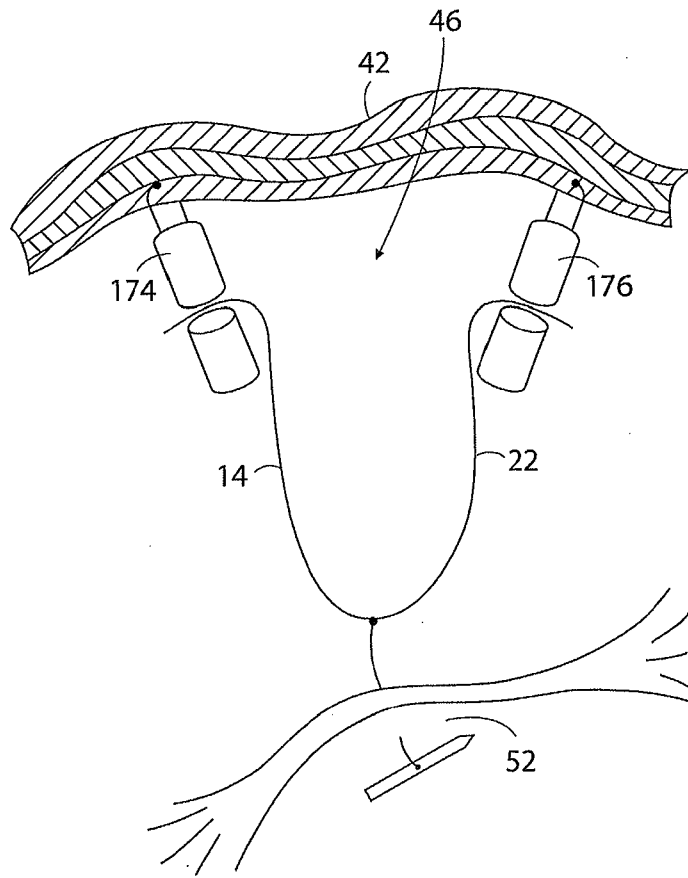


FIG. 23

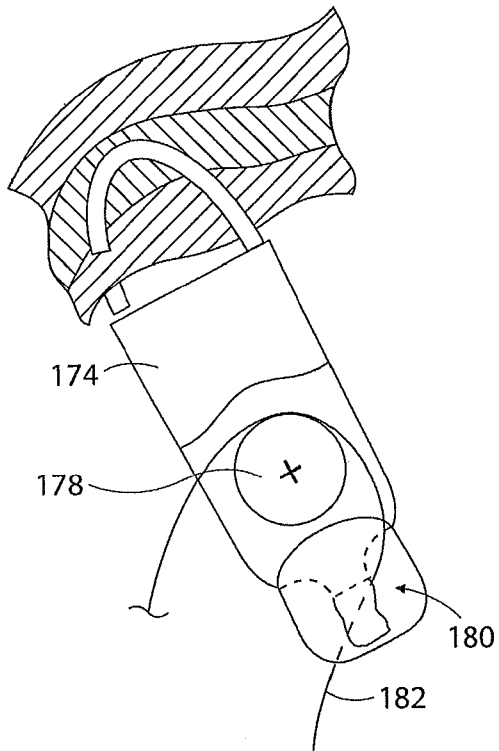


FIG. 24A

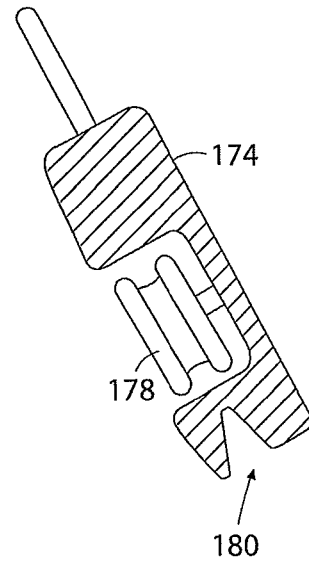


FIG. 24B

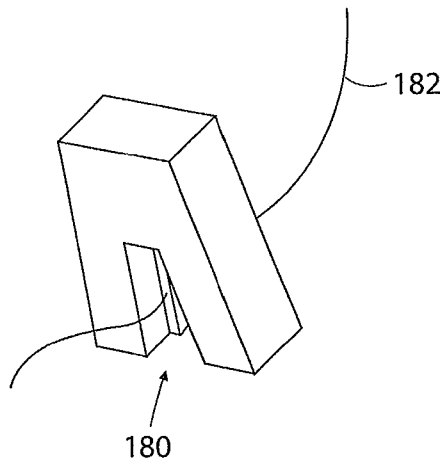


FIG. 24C

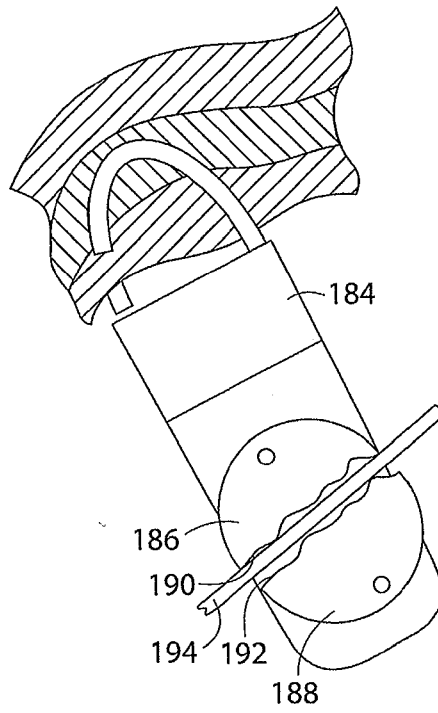


FIG. 25

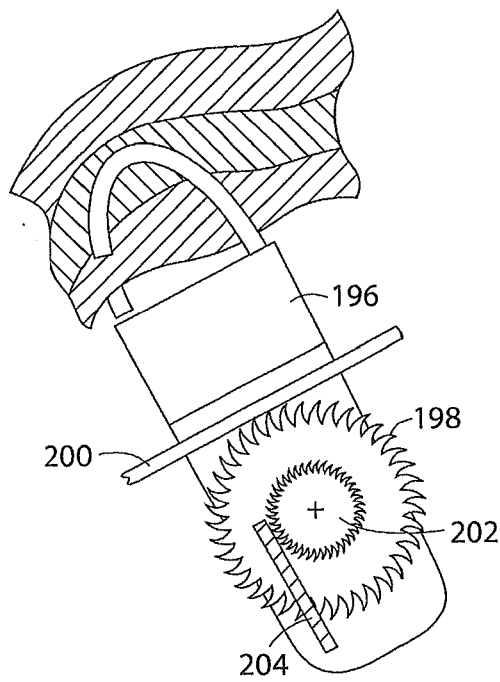


FIG. 26

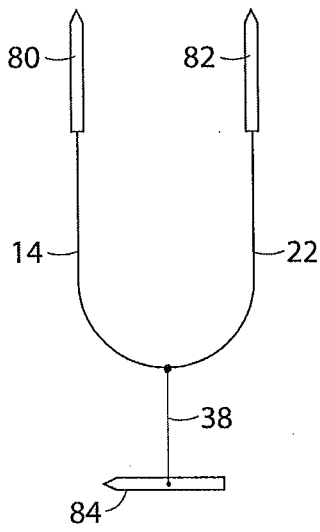


FIG. 27

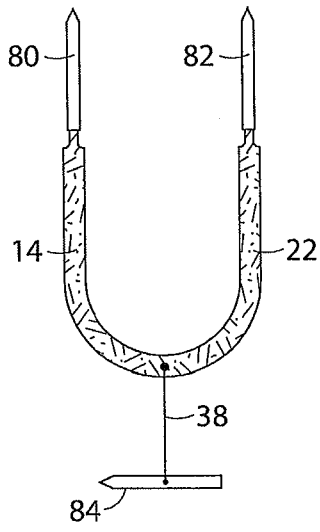


FIG. 28

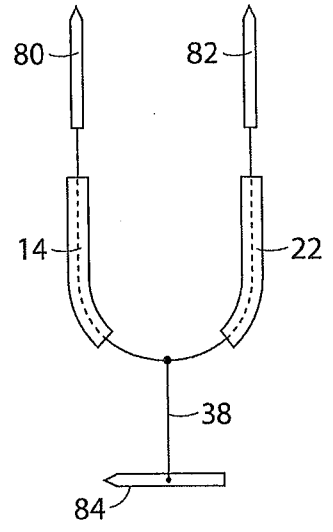


FIG. 29

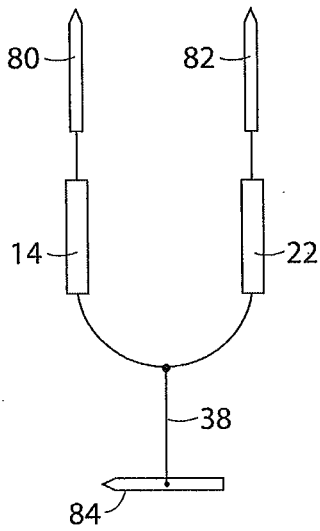


FIG. 30

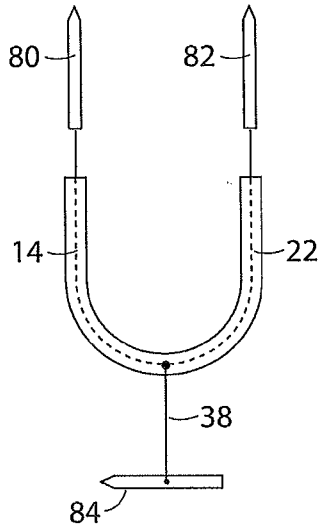


FIG. 31

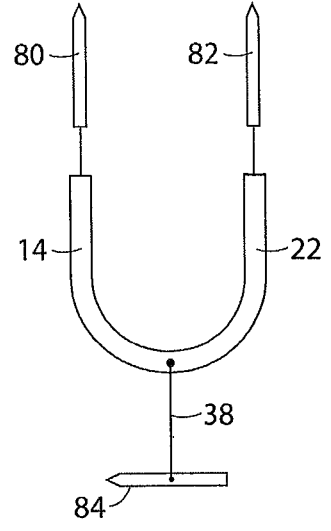


FIG. 32

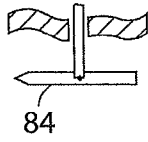


FIG. 33



FIG. 34

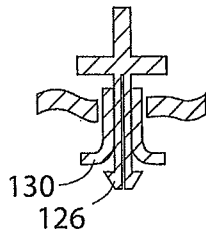


FIG. 35

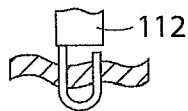


FIG. 36

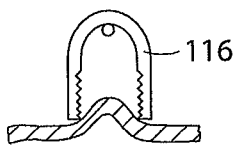


FIG. 37

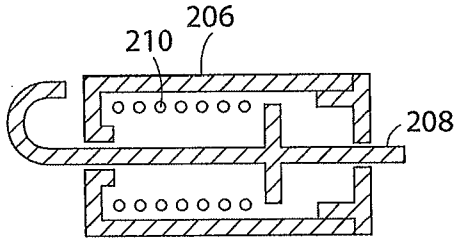


FIG. 38

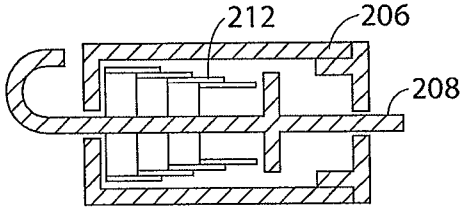


FIG. 39A

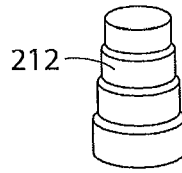


FIG. 39B

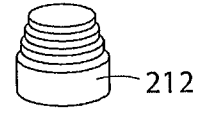


FIG. 39C

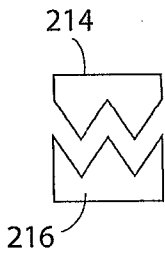


FIG. 40B

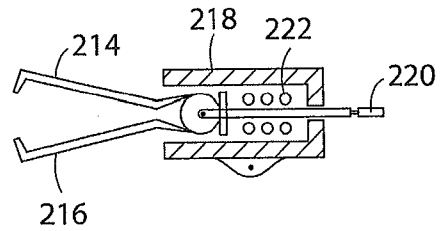


FIG. 40A

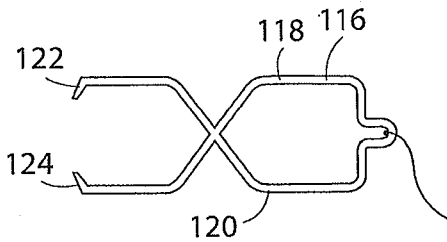


FIG. 41

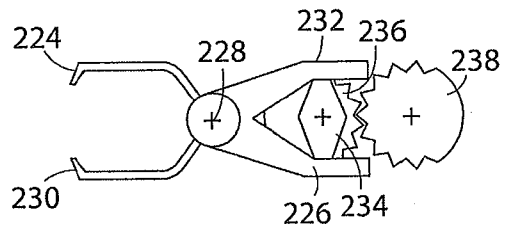


FIG. 42

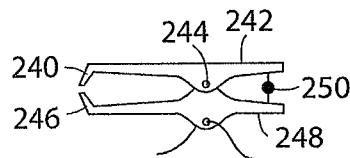


FIG. 43

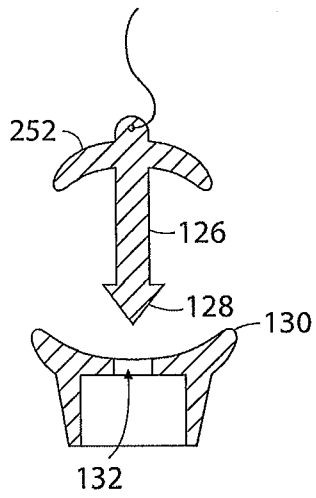


FIG. 44A

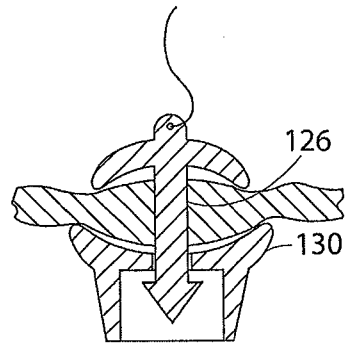


FIG. 44B

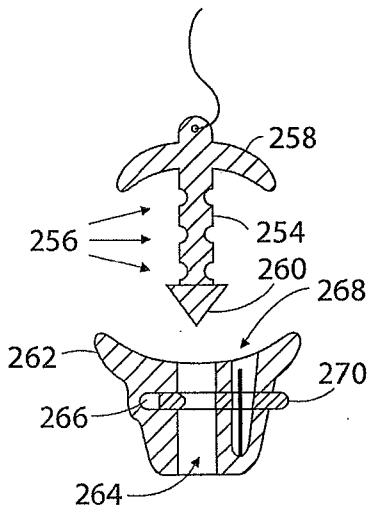


FIG. 45A

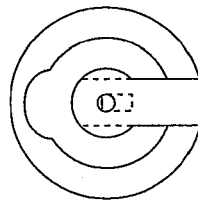


FIG. 45B

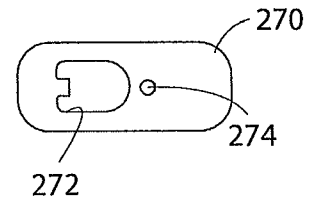


FIG. 45C

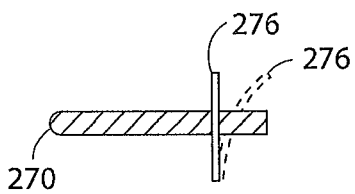


FIG. 45D

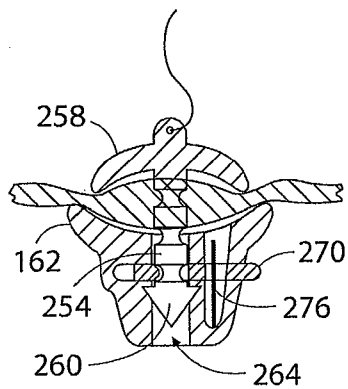
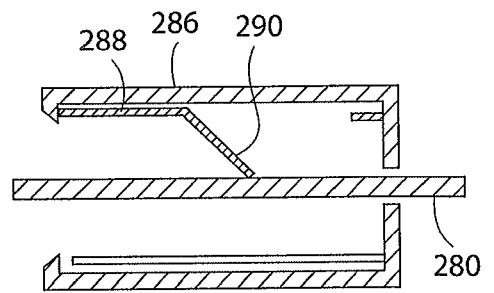
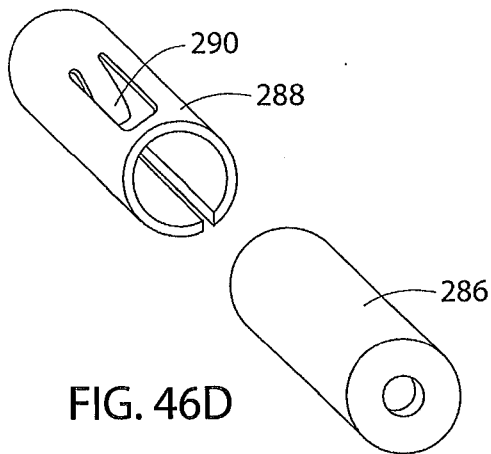
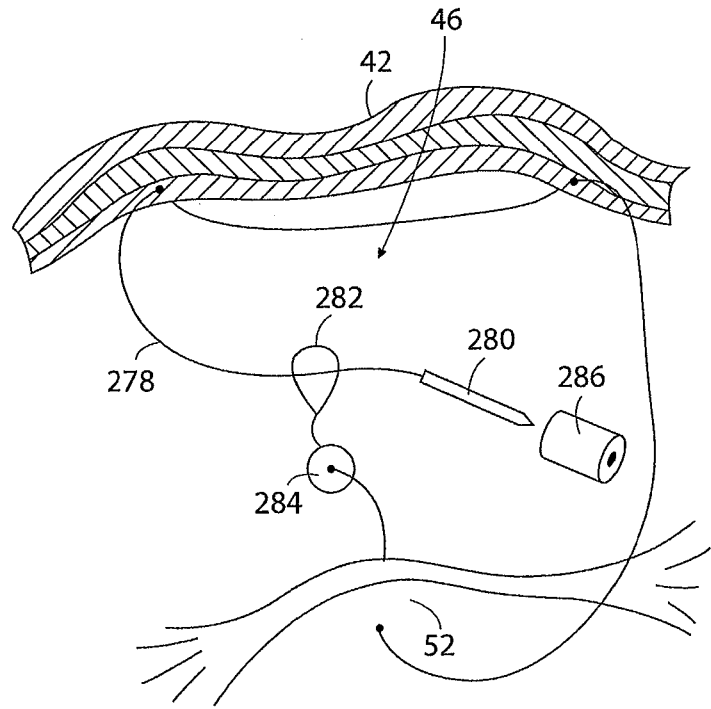
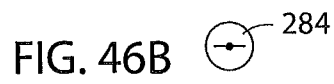
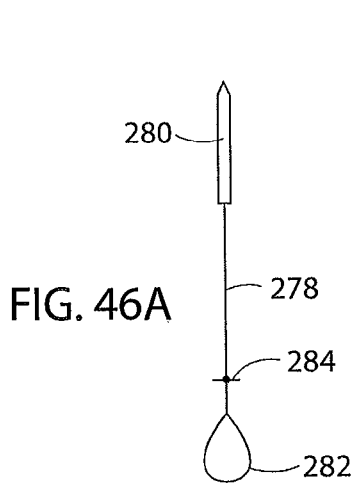


FIG. 45E



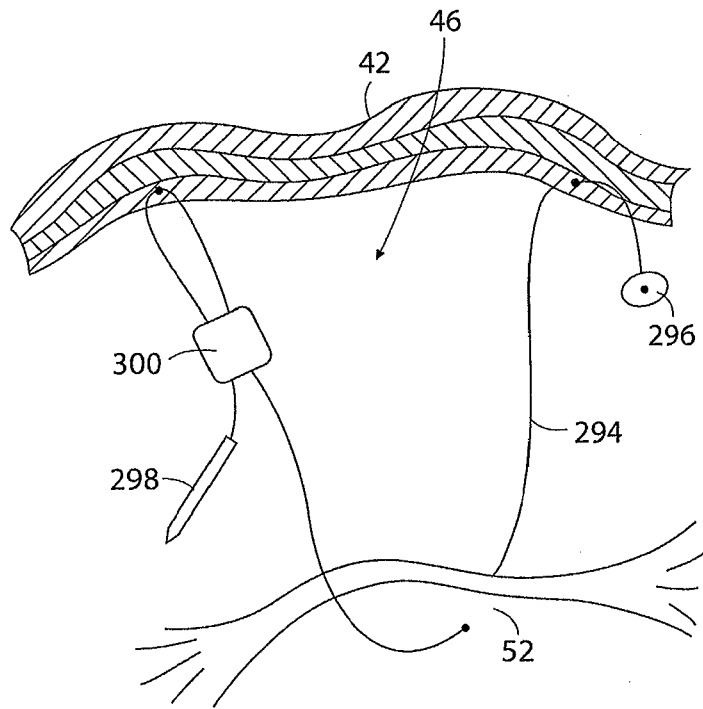


FIG. 46C

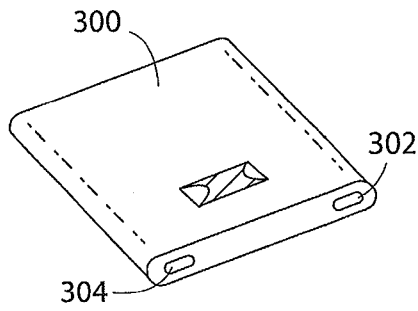


FIG. 47B

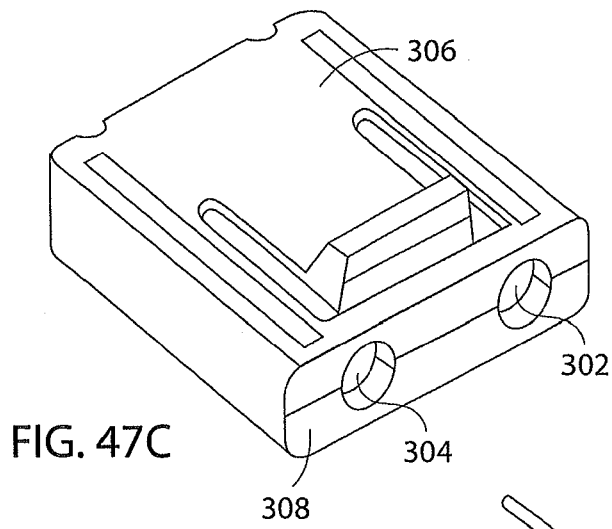


FIG. 47C

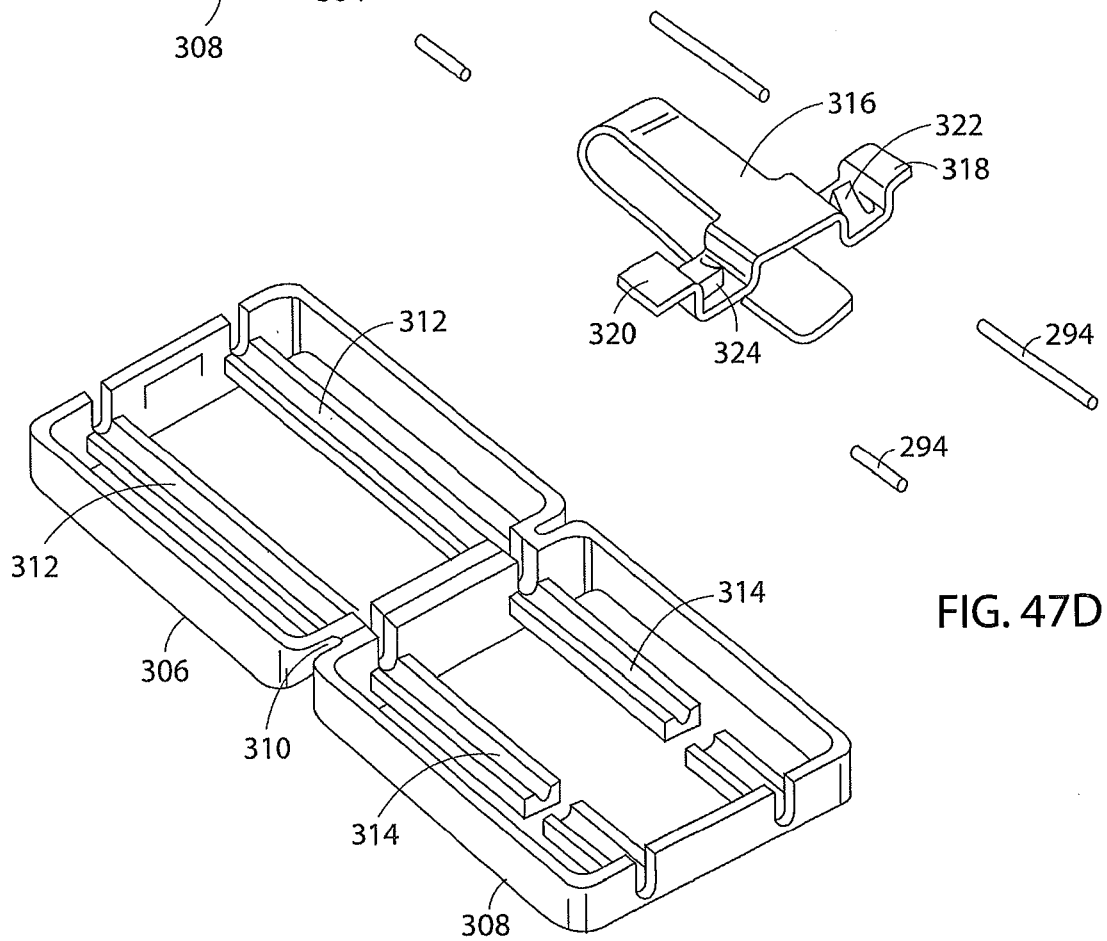


FIG. 47D

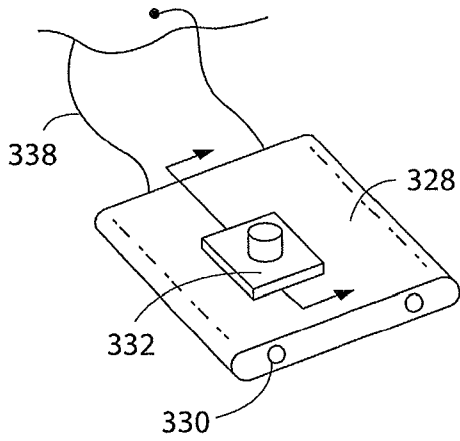


FIG. 48A

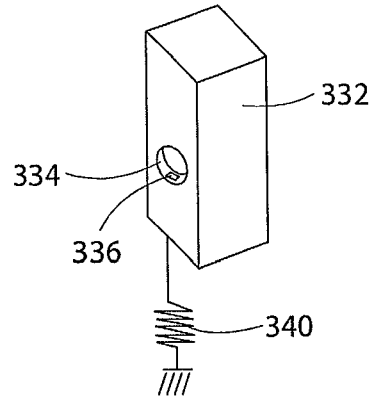


FIG. 48B

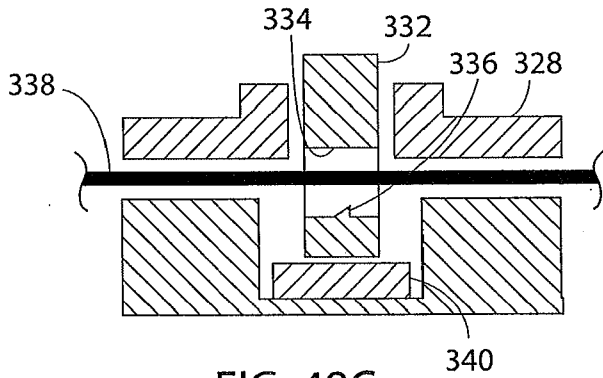


FIG. 48C

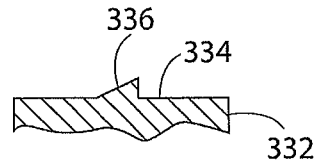


FIG. 48D

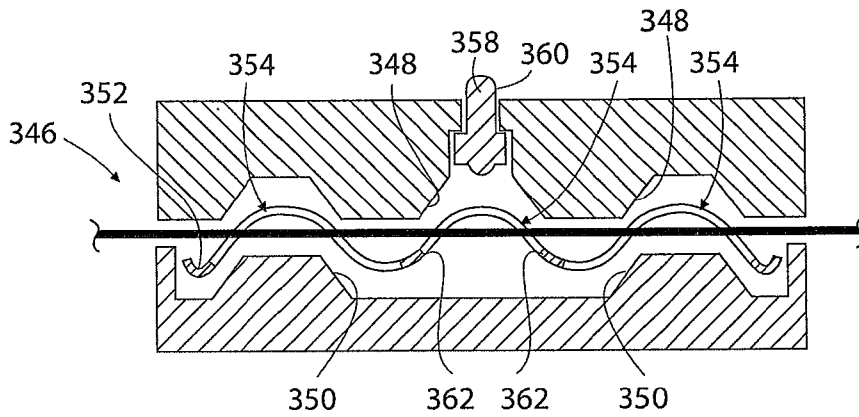


FIG. 49A

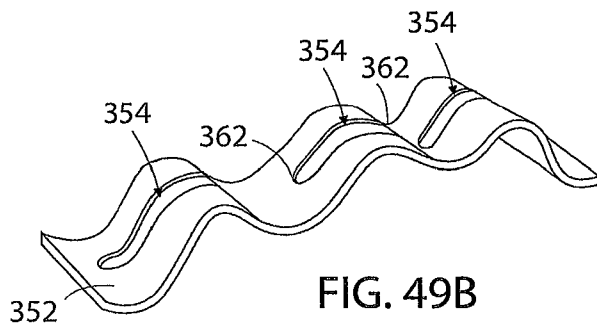
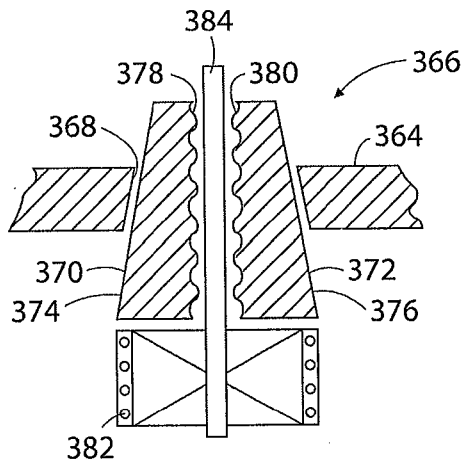
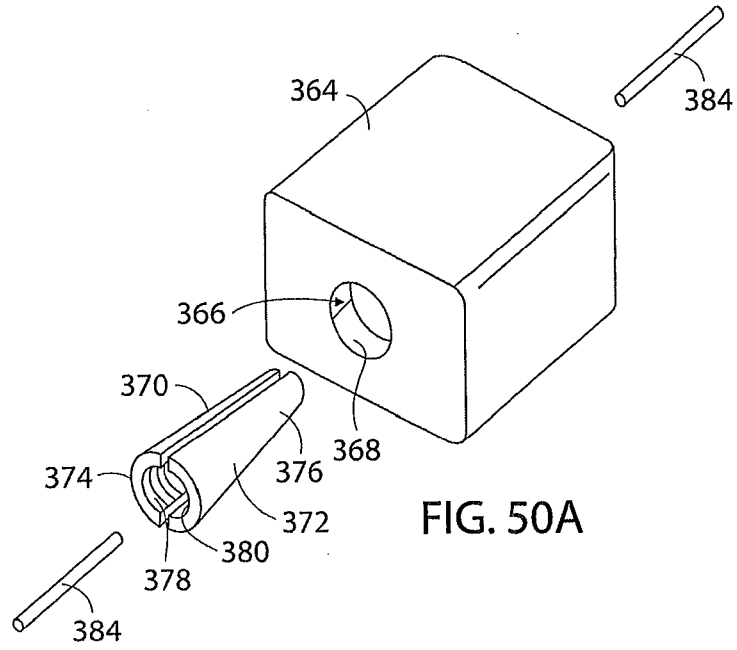


FIG. 49B



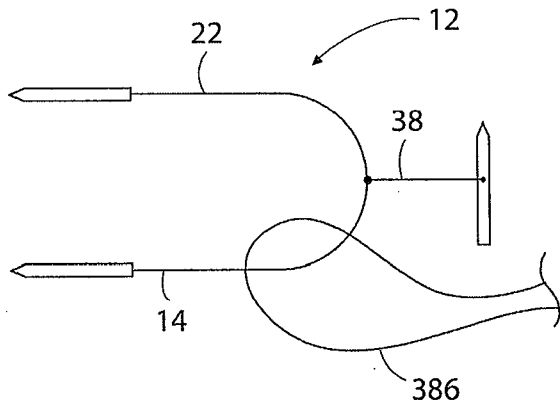


FIG. 51A

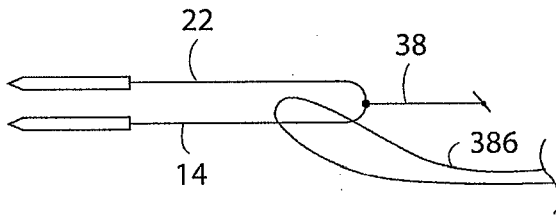


FIG. 51B

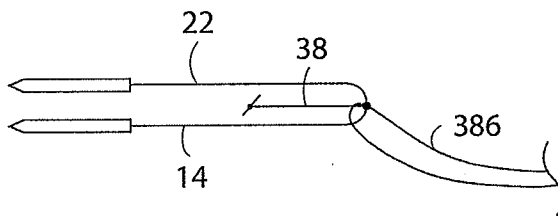


FIG. 51C

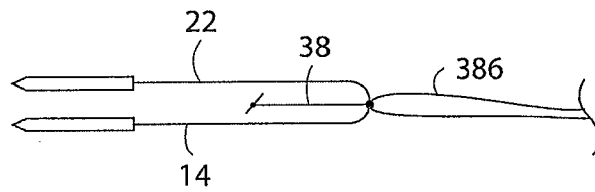


FIG. 51D

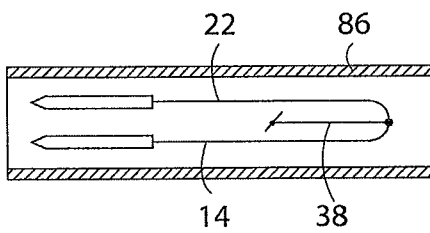


FIG. 51E

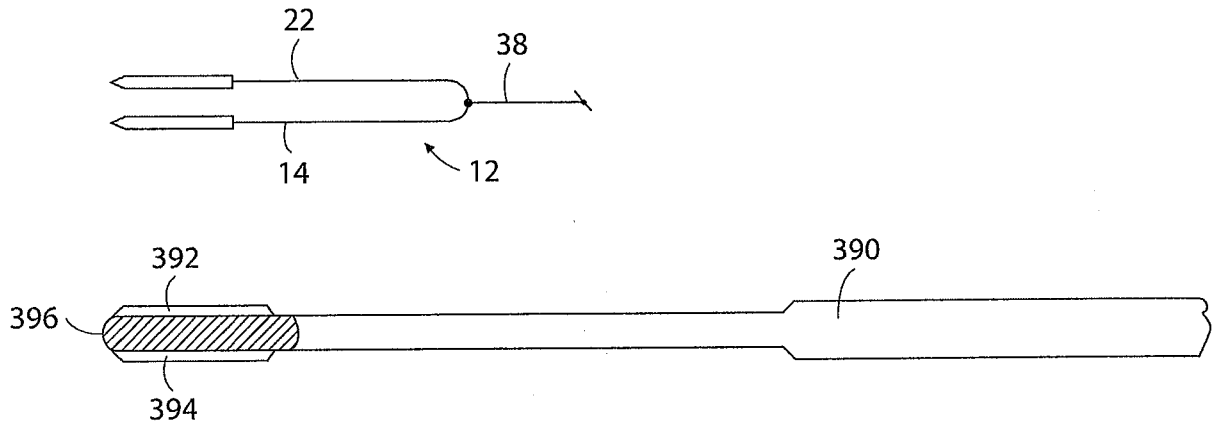


FIG. 52A

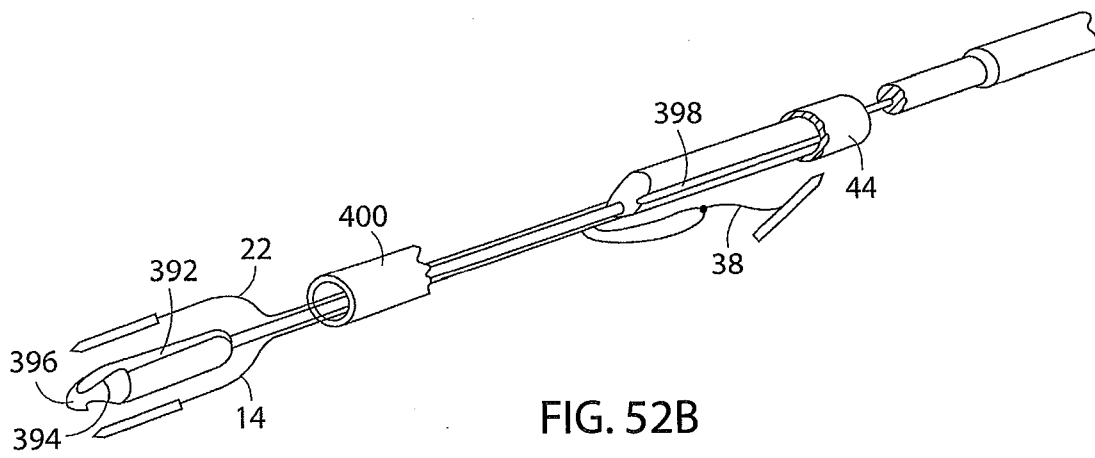


FIG. 52B

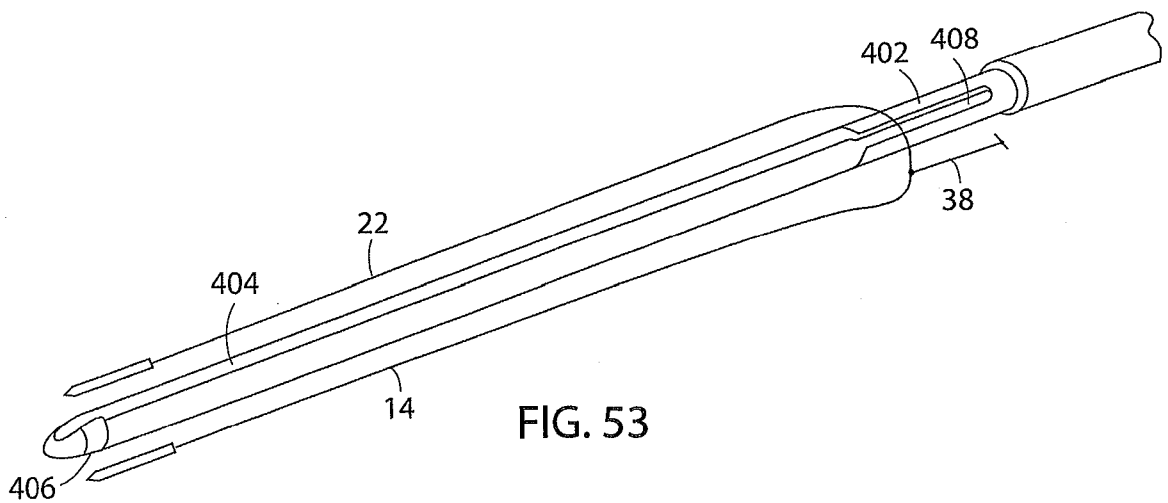


FIG. 53

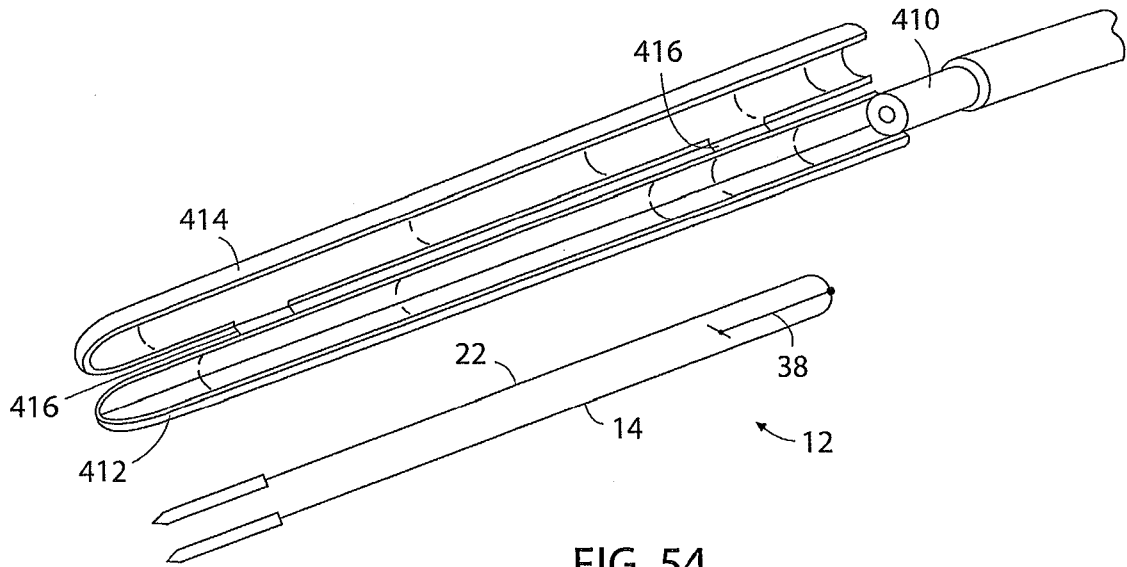


FIG. 54

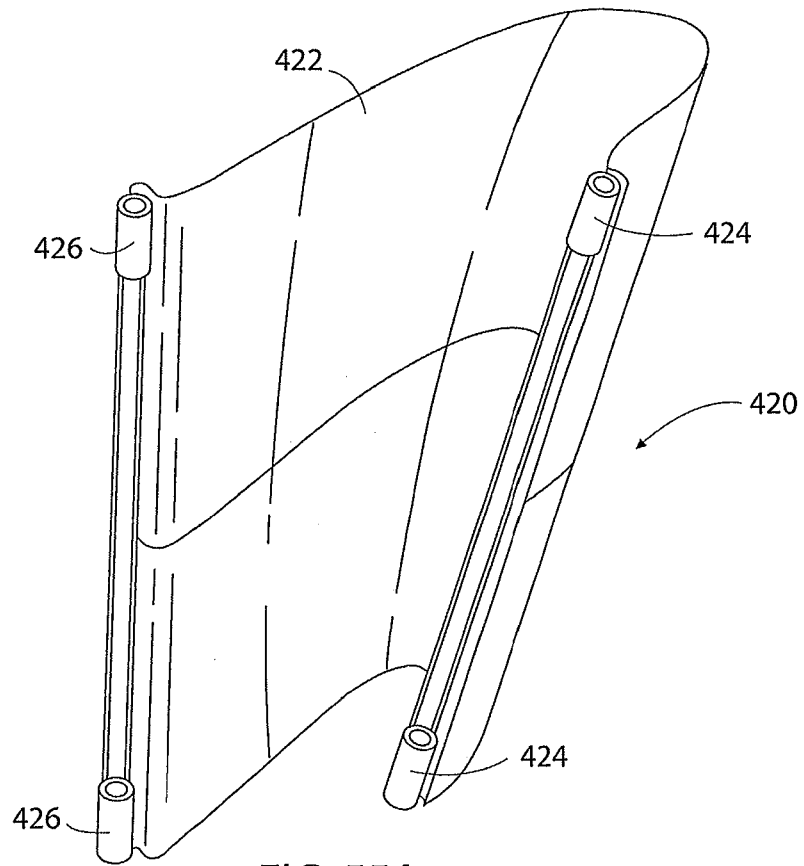


FIG. 55A

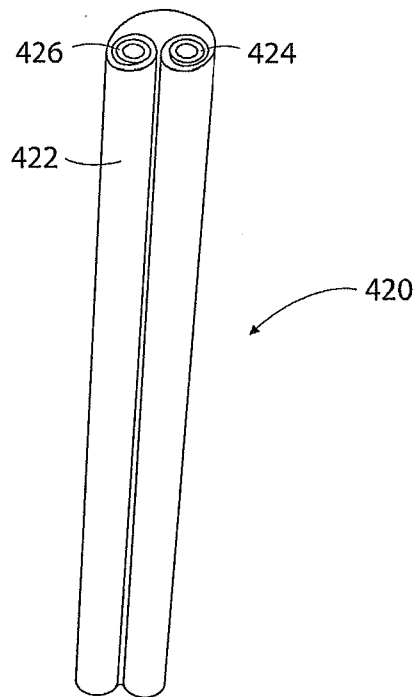


FIG. 55B

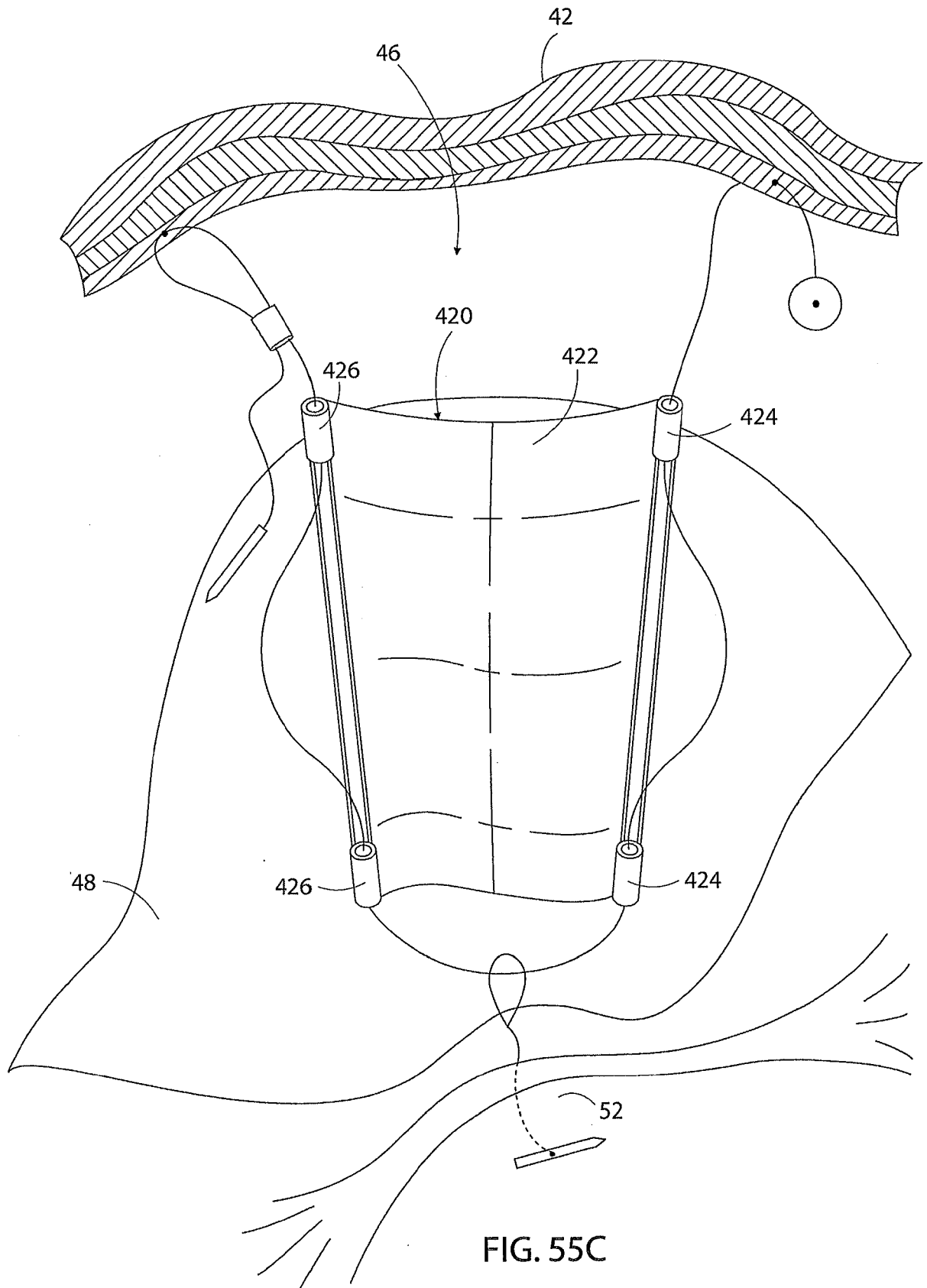
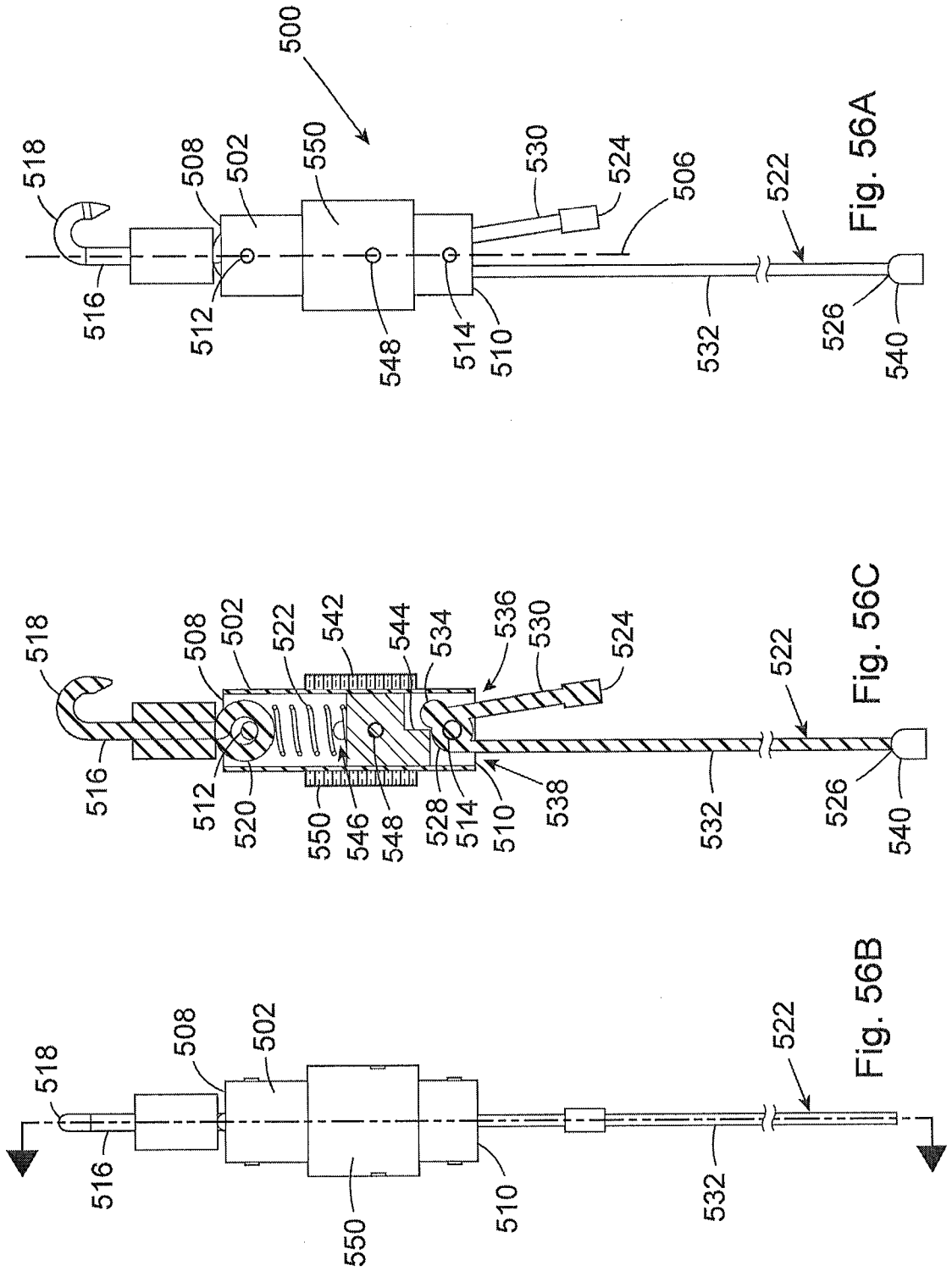
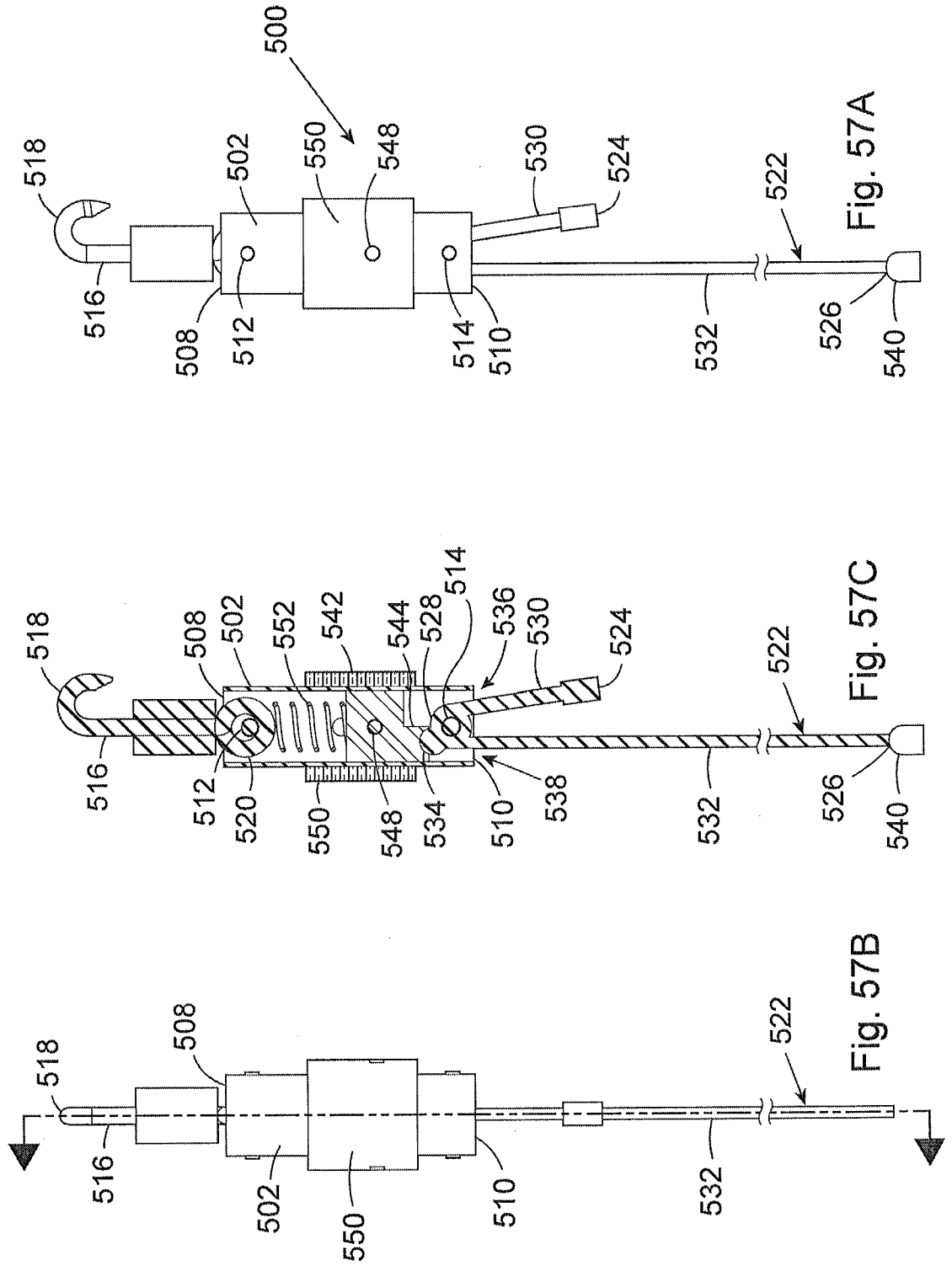
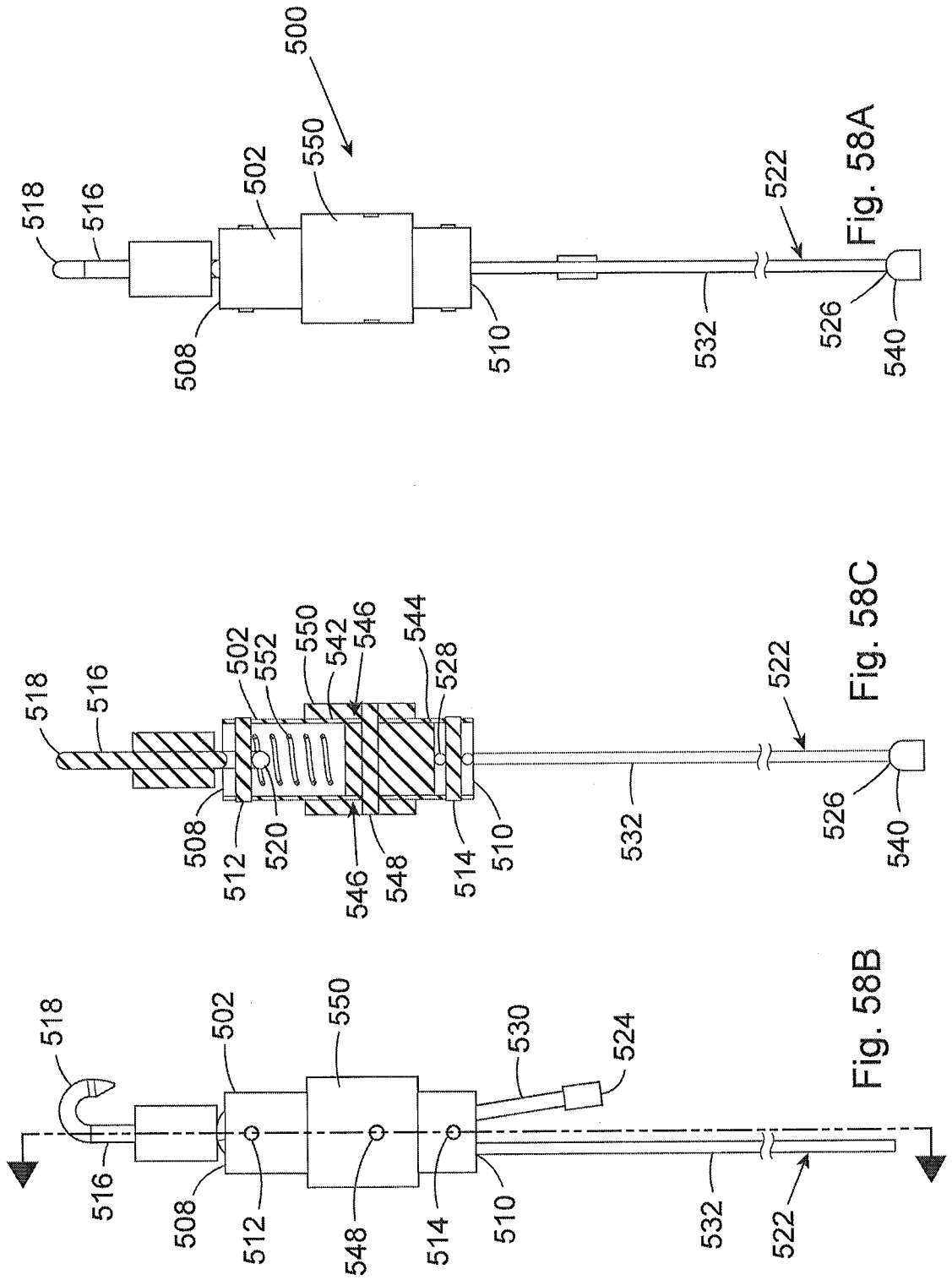
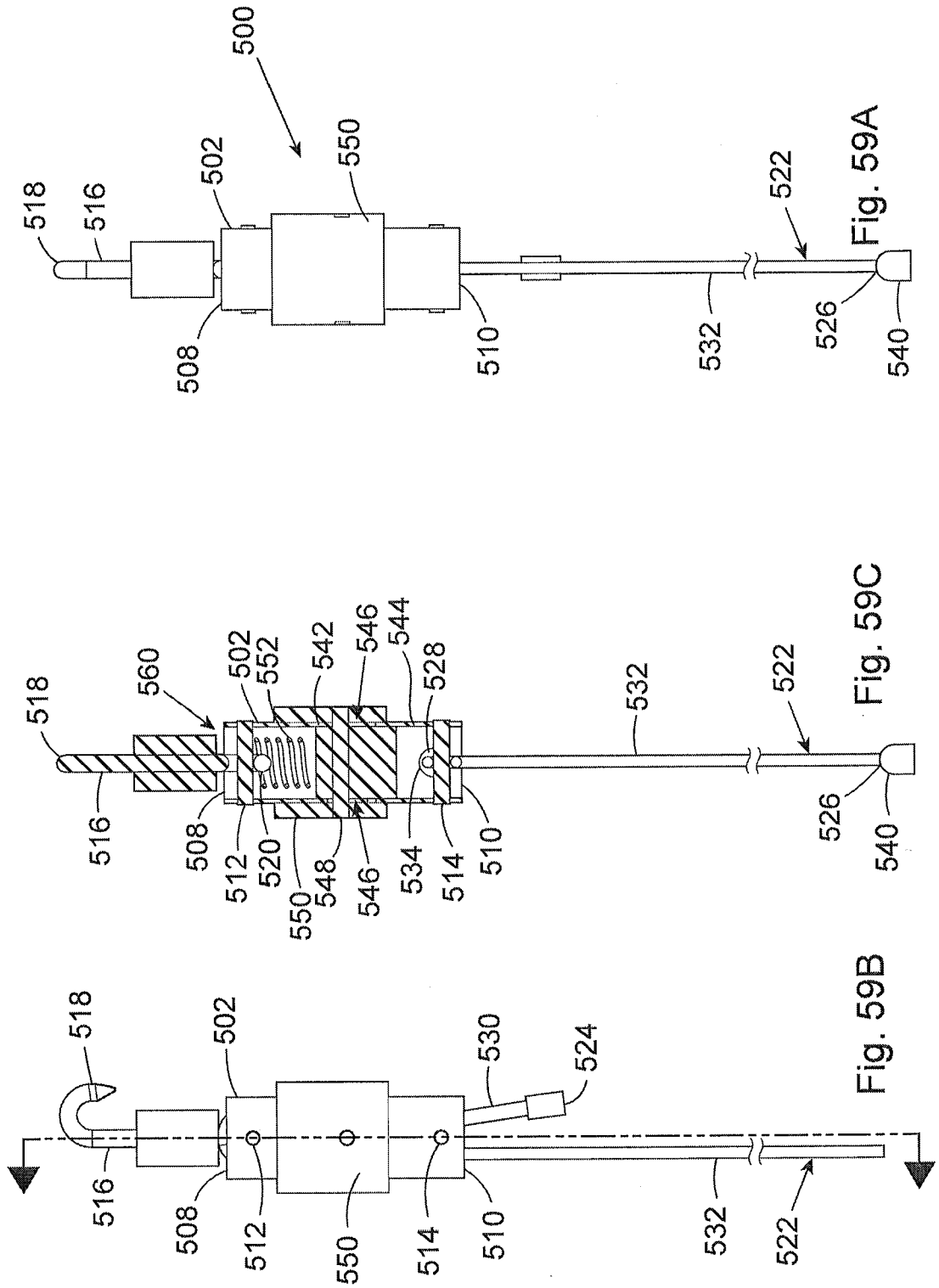


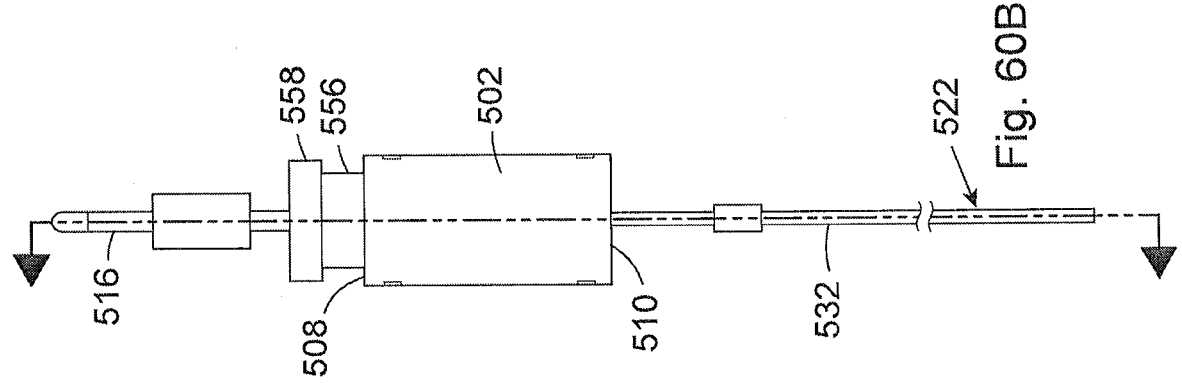
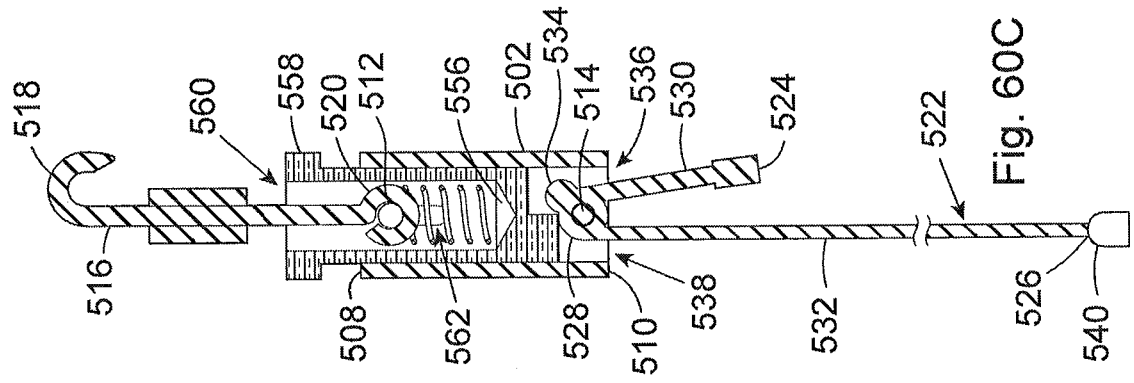
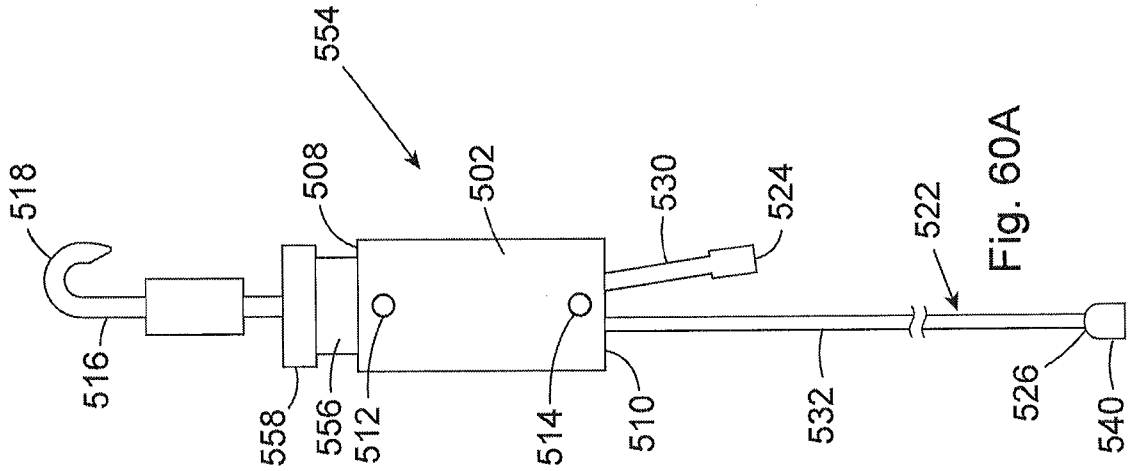
FIG. 55C

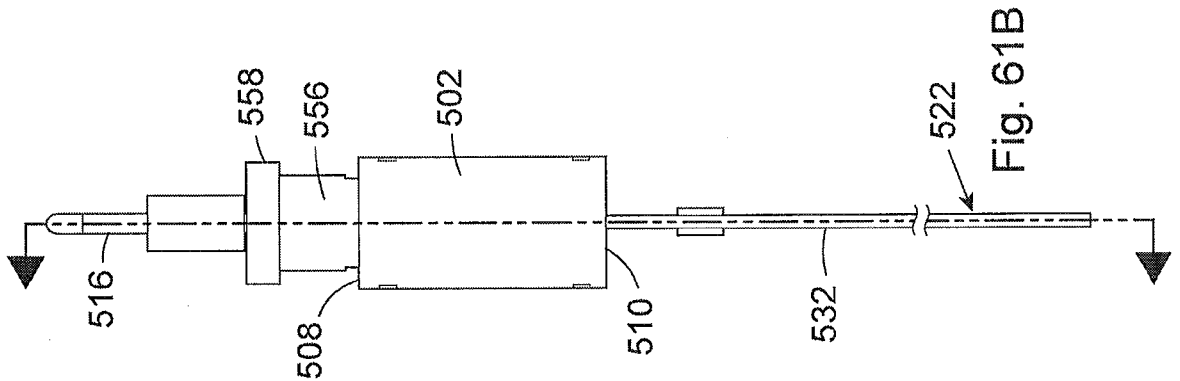
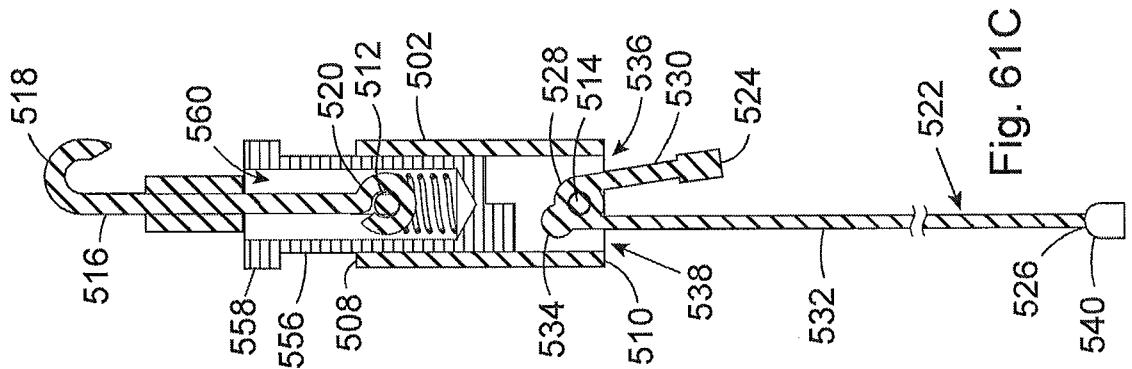
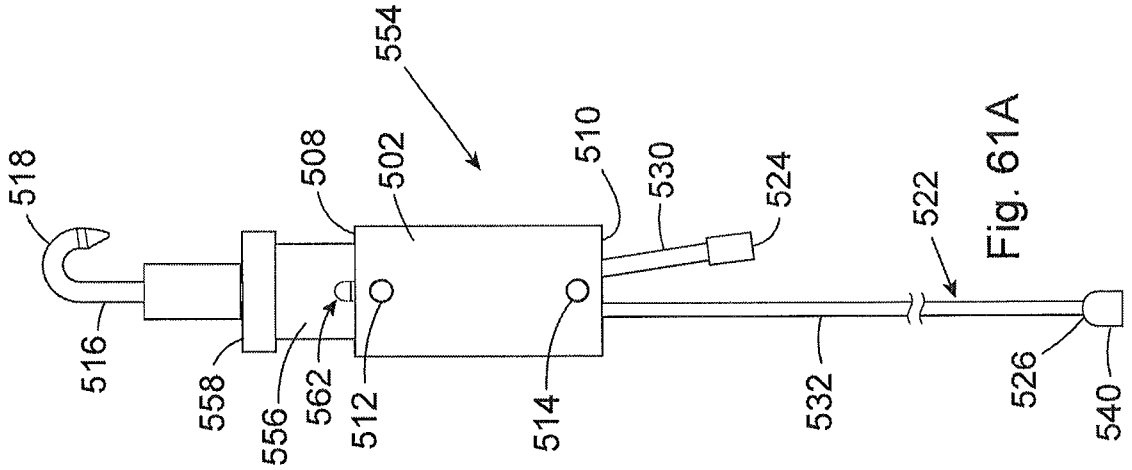


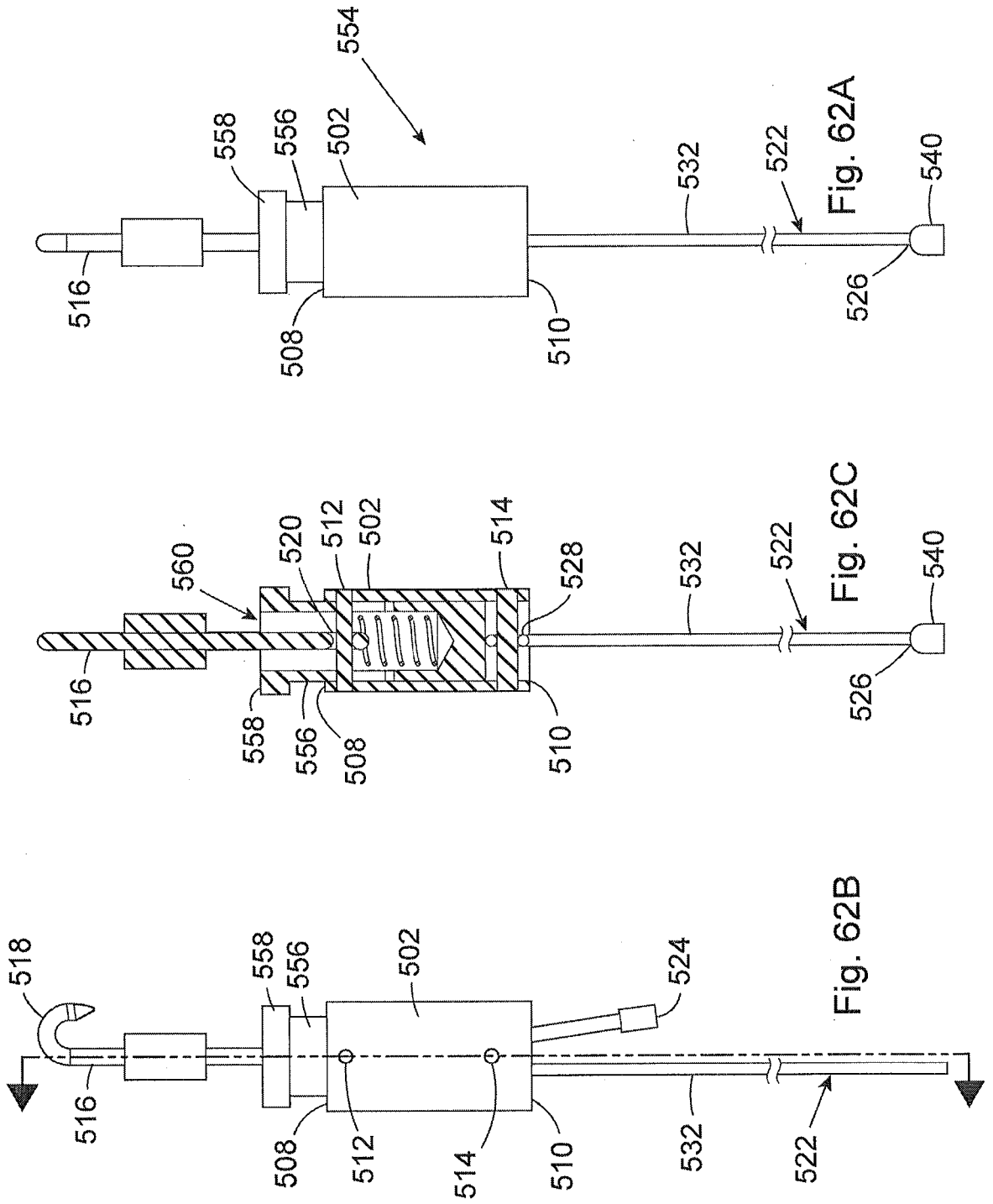


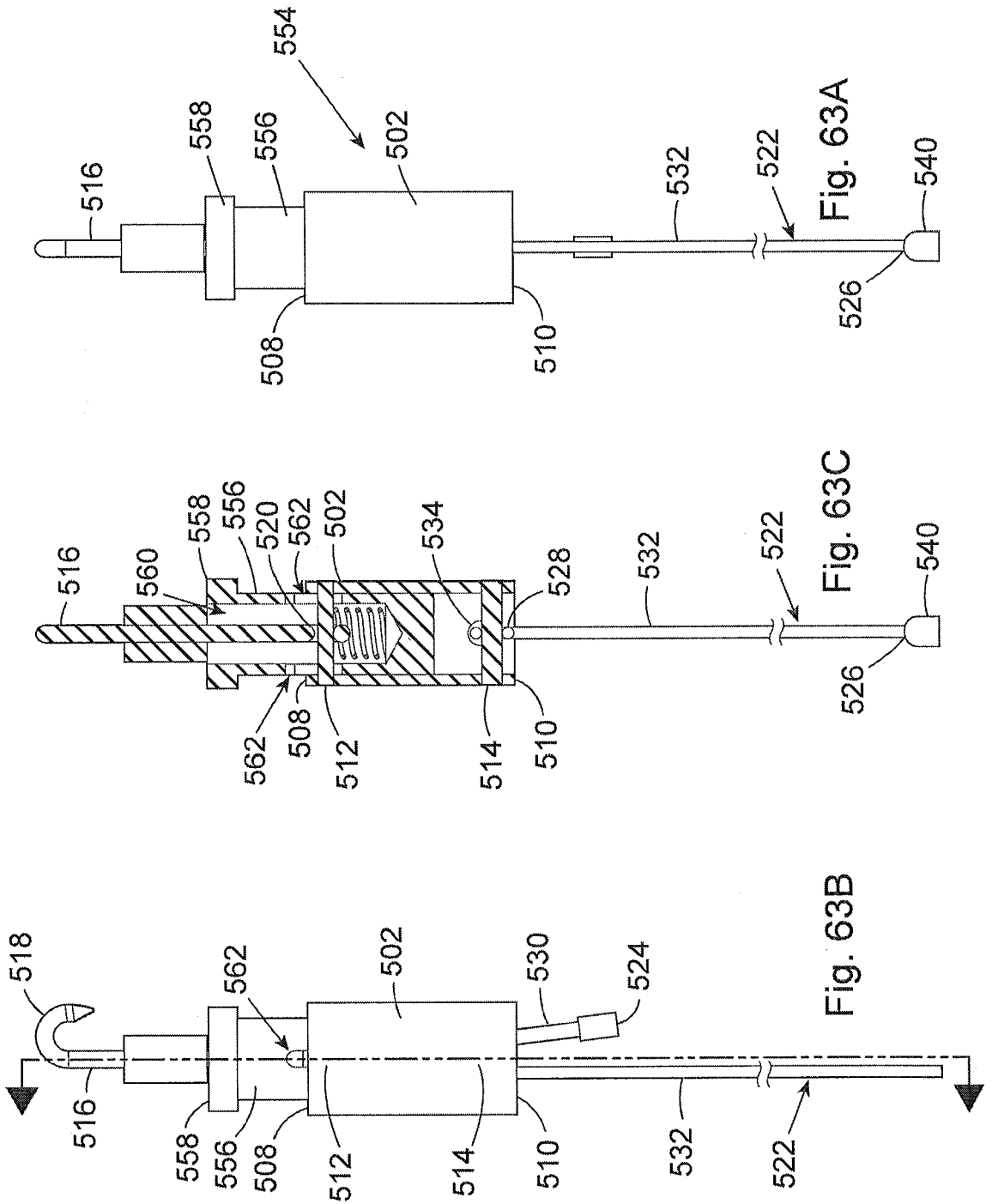












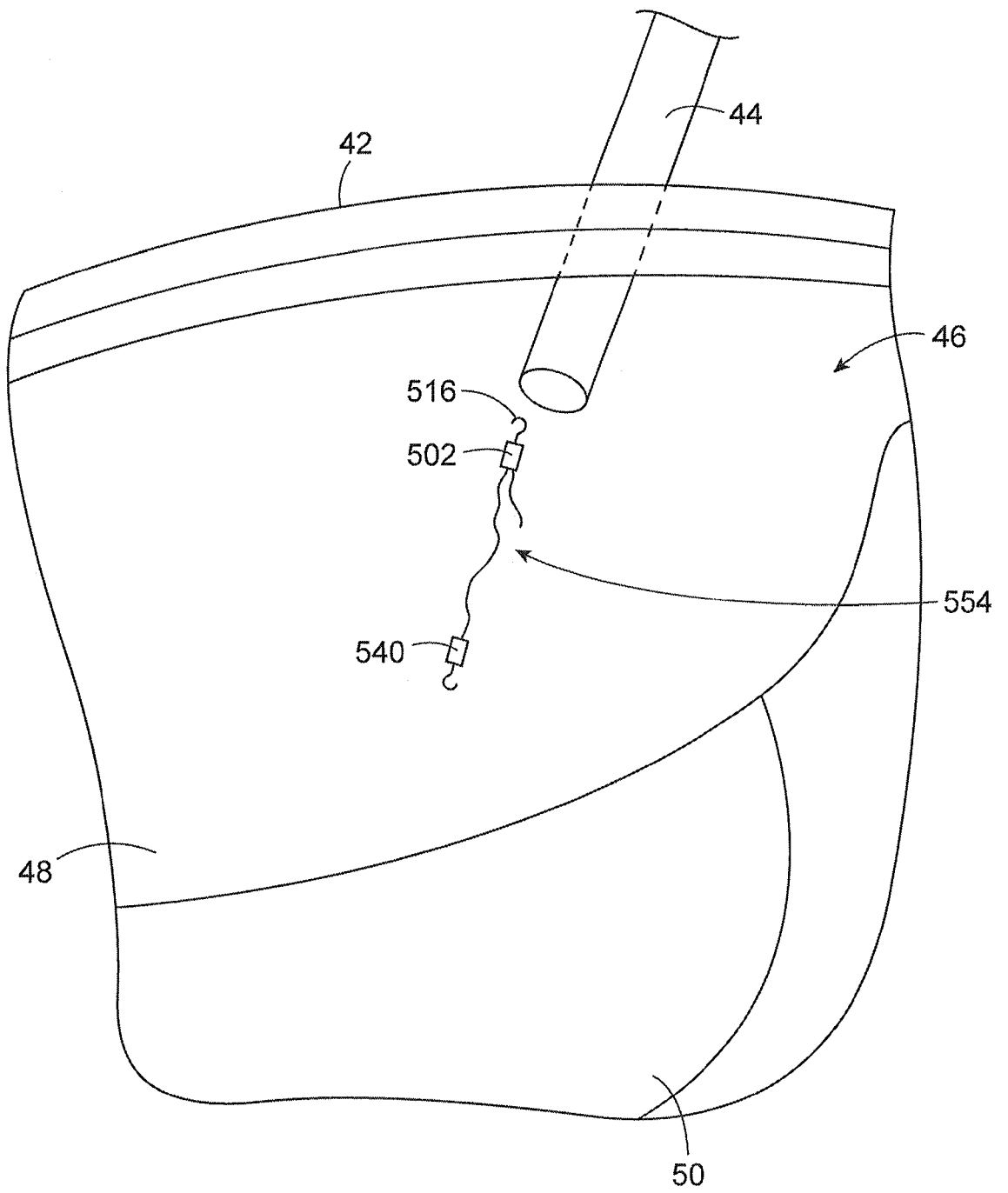


Fig. 64

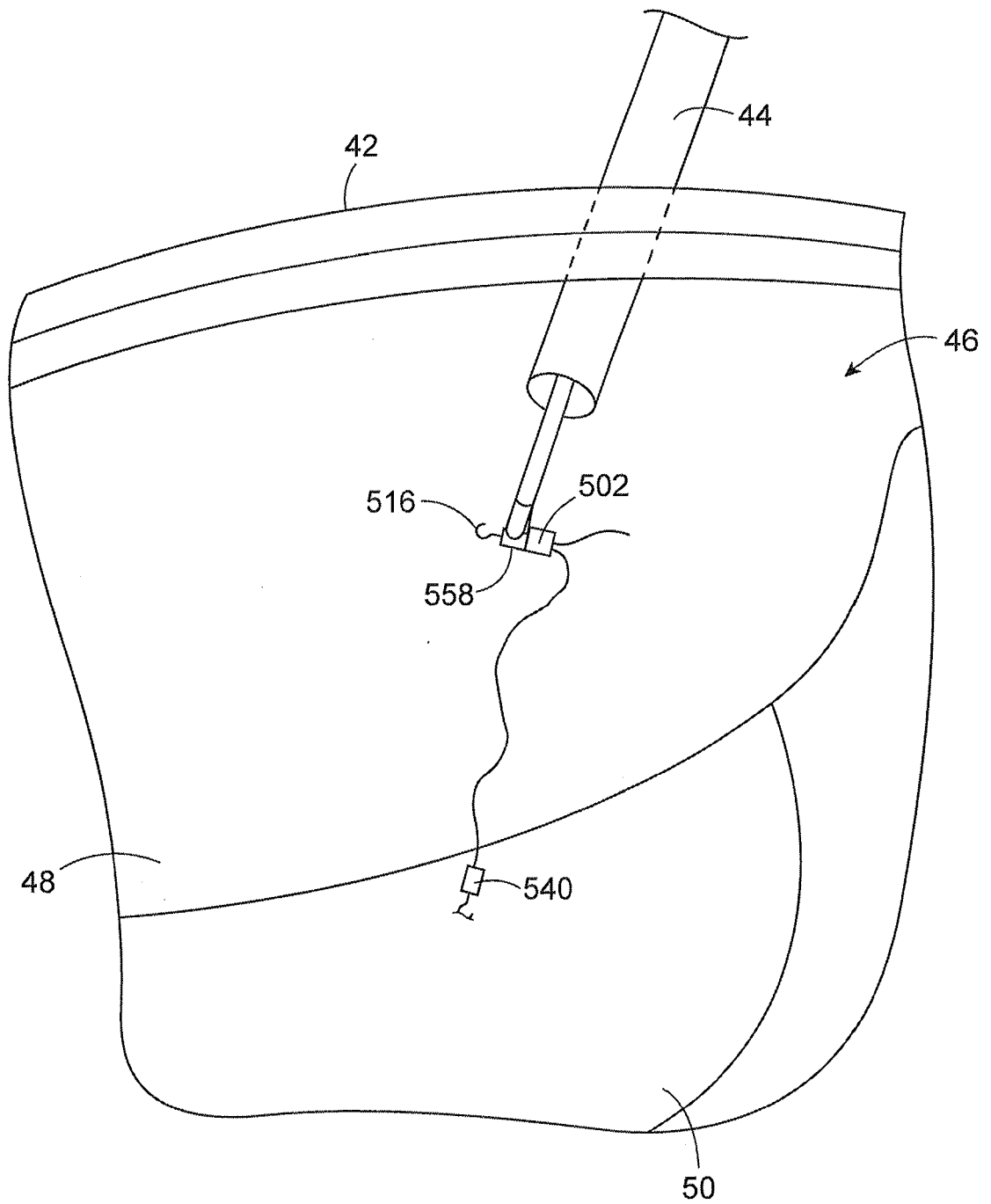


Fig. 65

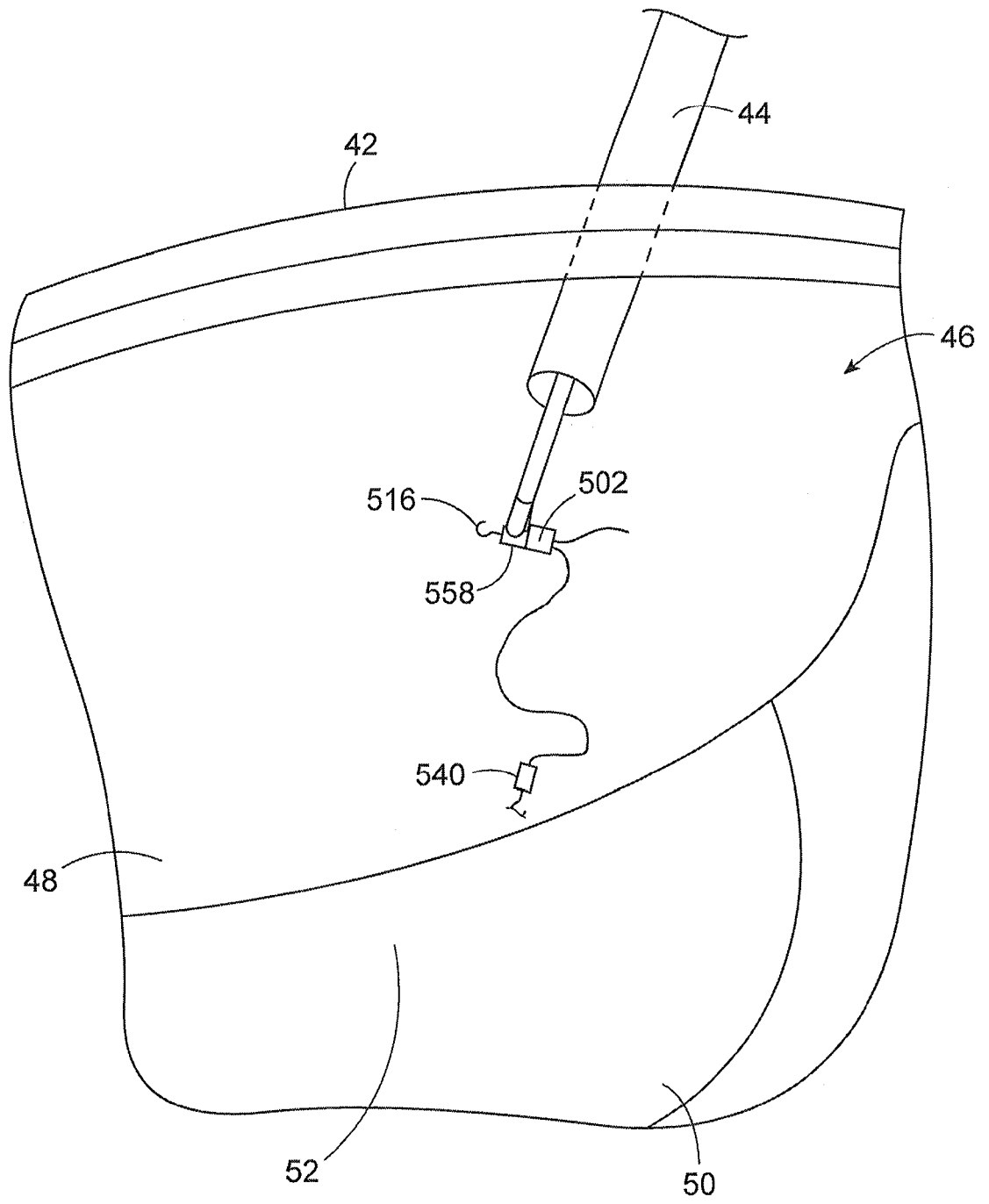


Fig. 66

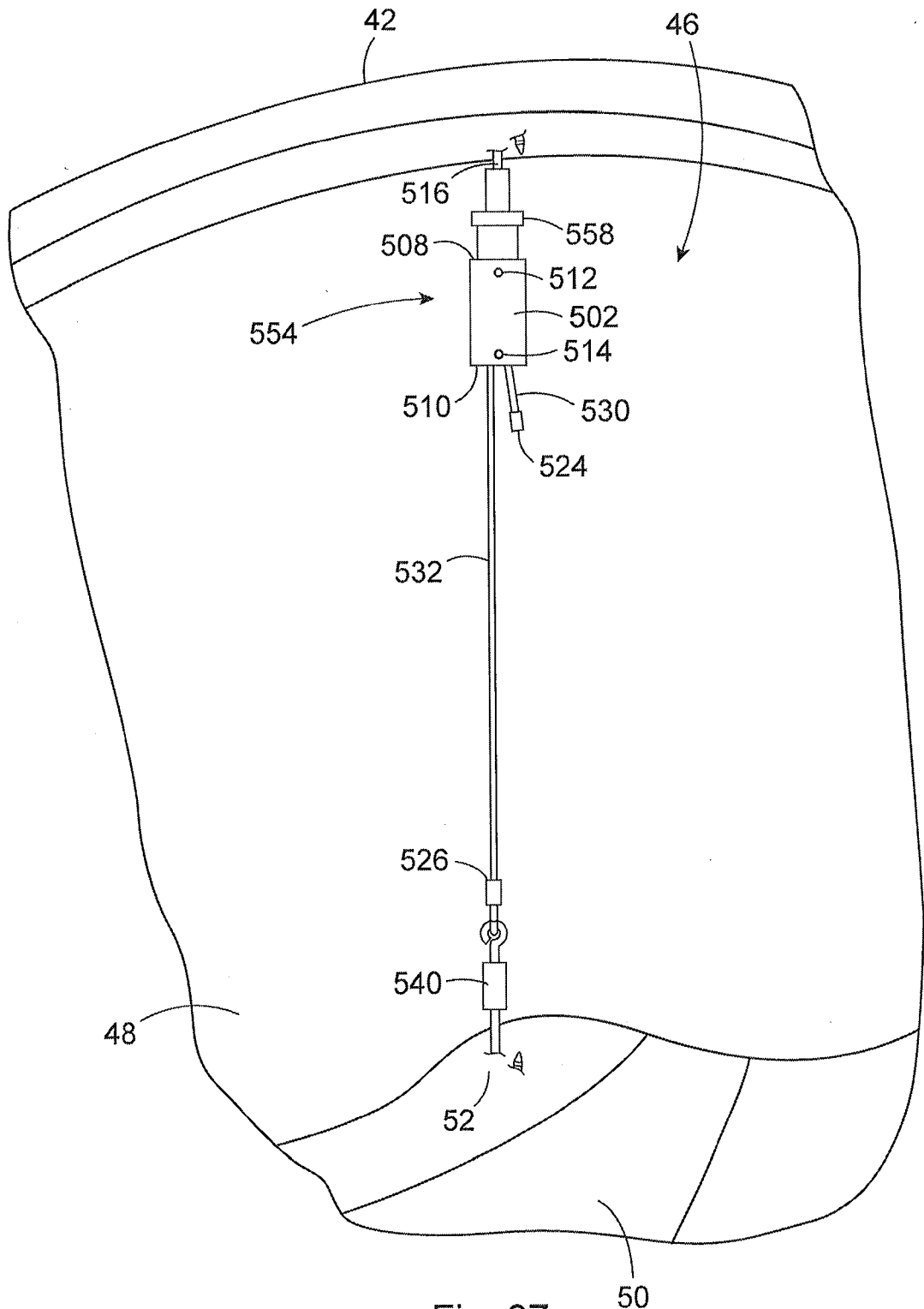


Fig. 67

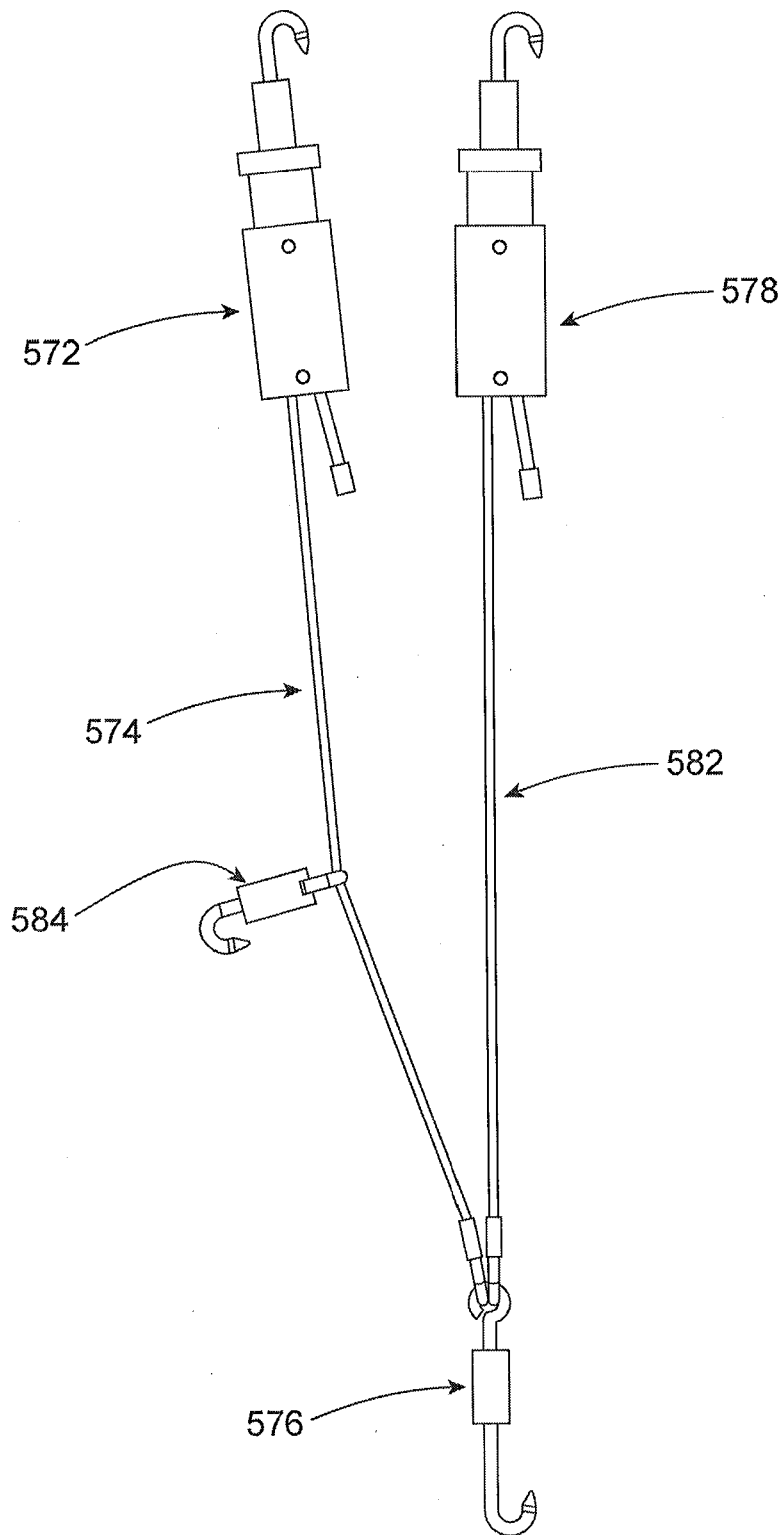


Fig. 68

INTERNATIONAL SEARCH REPORT

International application No.

PCT/US2011/001494

<p>A. CLASSIFICATION OF SUBJECT MATTER IPC(8) - A61B 17/10 (2011.01) USPC - 600/37 According to International Patent Classification (IPC) or to both national classification and IPC</p>																	
<p>B. FIELDS SEARCHED</p> <p>Minimum documentation searched (classification system followed by classification symbols) IPC(8) - A61B 17/08, 17/10 (2011.01) USPC - 24/all subclass, 68CD, 68T, 71CT, 71T, 115G, 115H, 115M, 136K, 136L, 136R, 712.5; 403/211, 211.374, 385, 396, 409;</p> <p>Documentation searched other than minimum documentation to the extent that such documents are included in the fields searched USPC - 600/37; 606/72, 74, 103</p> <p>Electronic data base consulted during the international search (name of data base and, where practicable, search terms used) PatBase and Google Patents</p>																	
<p>C. DOCUMENTS CONSIDERED TO BE RELEVANT</p> <table border="1" style="width:100%; border-collapse: collapse;"> <thead> <tr> <th style="width:10%;">Category*</th> <th style="width:70%;">Citation of document, with indication, where appropriate, of the relevant passages</th> <th style="width:20%;">Relevant to claim No.</th> </tr> </thead> <tbody> <tr> <td>X</td> <td>US 2009/0137862 A1 (EVANS et al) 28 May 2009 (28.05.2009) entire document</td> <td>1-10, 25-29</td> </tr> <tr> <td>A</td> <td>US 5,193,955 A (CHOU) 16 March 1993 (16.03.1993) entire document</td> <td>1-31</td> </tr> <tr> <td>A</td> <td>US 2010/0292732 A1 (HIROTSUKA et al) 18 November 2010 (18.11.2010) entire document</td> <td>1-31</td> </tr> <tr> <td>A</td> <td>US 302,509 A (MAUTHNER) 22 July 1884 (22. 07.1884) entire document</td> <td>1-31</td> </tr> </tbody> </table>			Category*	Citation of document, with indication, where appropriate, of the relevant passages	Relevant to claim No.	X	US 2009/0137862 A1 (EVANS et al) 28 May 2009 (28.05.2009) entire document	1-10, 25-29	A	US 5,193,955 A (CHOU) 16 March 1993 (16.03.1993) entire document	1-31	A	US 2010/0292732 A1 (HIROTSUKA et al) 18 November 2010 (18.11.2010) entire document	1-31	A	US 302,509 A (MAUTHNER) 22 July 1884 (22. 07.1884) entire document	1-31
Category*	Citation of document, with indication, where appropriate, of the relevant passages	Relevant to claim No.															
X	US 2009/0137862 A1 (EVANS et al) 28 May 2009 (28.05.2009) entire document	1-10, 25-29															
A	US 5,193,955 A (CHOU) 16 March 1993 (16.03.1993) entire document	1-31															
A	US 2010/0292732 A1 (HIROTSUKA et al) 18 November 2010 (18.11.2010) entire document	1-31															
A	US 302,509 A (MAUTHNER) 22 July 1884 (22. 07.1884) entire document	1-31															
<p><input type="checkbox"/> Further documents are listed in the continuation of Box C. <input type="checkbox"/></p>																	
<p>* Special categories of cited documents:</p> <table style="width:100%;"> <tr> <td style="width:50%;"> <p>“A” document defining the general state of the art which is not considered to be of particular relevance</p> <p>“E” earlier application or patent but published on or after the international filing date</p> <p>“L” document which may throw doubts on priority claim(s) or which is cited to establish the publication date of another citation or other special reason (as specified)</p> <p>“O” document referring to an oral disclosure, use, exhibition or other means</p> <p>“P” document published prior to the international filing date but later than the priority date claimed</p> </td> <td style="width:50%;"> <p>“T” later document published after the international filing date or priority date and not in conflict with the application but cited to understand the principle or theory underlying the invention</p> <p>“X” document of particular relevance; the claimed invention cannot be considered novel or cannot be considered to involve an inventive step when the document is taken alone</p> <p>“Y” document of particular relevance; the claimed invention cannot be considered to involve an inventive step when the document is combined with one or more other such documents, such combination being obvious to a person skilled in the art</p> <p>“&” document member of the same patent family</p> </td> </tr> </table>			<p>“A” document defining the general state of the art which is not considered to be of particular relevance</p> <p>“E” earlier application or patent but published on or after the international filing date</p> <p>“L” document which may throw doubts on priority claim(s) or which is cited to establish the publication date of another citation or other special reason (as specified)</p> <p>“O” document referring to an oral disclosure, use, exhibition or other means</p> <p>“P” document published prior to the international filing date but later than the priority date claimed</p>	<p>“T” later document published after the international filing date or priority date and not in conflict with the application but cited to understand the principle or theory underlying the invention</p> <p>“X” document of particular relevance; the claimed invention cannot be considered novel or cannot be considered to involve an inventive step when the document is taken alone</p> <p>“Y” document of particular relevance; the claimed invention cannot be considered to involve an inventive step when the document is combined with one or more other such documents, such combination being obvious to a person skilled in the art</p> <p>“&” document member of the same patent family</p>													
<p>“A” document defining the general state of the art which is not considered to be of particular relevance</p> <p>“E” earlier application or patent but published on or after the international filing date</p> <p>“L” document which may throw doubts on priority claim(s) or which is cited to establish the publication date of another citation or other special reason (as specified)</p> <p>“O” document referring to an oral disclosure, use, exhibition or other means</p> <p>“P” document published prior to the international filing date but later than the priority date claimed</p>	<p>“T” later document published after the international filing date or priority date and not in conflict with the application but cited to understand the principle or theory underlying the invention</p> <p>“X” document of particular relevance; the claimed invention cannot be considered novel or cannot be considered to involve an inventive step when the document is taken alone</p> <p>“Y” document of particular relevance; the claimed invention cannot be considered to involve an inventive step when the document is combined with one or more other such documents, such combination being obvious to a person skilled in the art</p> <p>“&” document member of the same patent family</p>																
<p>Date of the actual completion of the international search</p> <p>05 December 2011</p>		<p>Date of mailing of the international search report</p> <p align="center" style="font-size: 1.2em;">25 APR 2012</p>															
<p>Name and mailing address of the ISA/US</p> <p>Mail Stop PCT, Attn: ISA/US, Commissioner for Patents P.O. Box 1450, Alexandria, Virginia 22313-1450 Facsimile No. 571-273-3201</p>		<p>Authorized officer:</p> <p align="center">Blaine R. Copenheaver</p> <p><small>PCT Helpdesk: 571-272-4300 PCT OSP: 571-272-7774</small></p>															

专利名称(译)	用于腹腔内移动第一内部器官到远离第二内部器官的位置然后将第一内部器官保持在该位置而无需手动输入的装置和方法		
公开(公告)号	EP2750613A1	公开(公告)日	2014-07-09
申请号	EP2011871286	申请日	2011-08-25
[标]申请(专利权)人(译)	SCOTT J STEPHEN SMITH JEFFREY		
申请(专利权)人(译)	SCOTT, J., STEPHEN SMITH, JEFFREY		
当前申请(专利权)人(译)	SCOTT, J., STEPHEN SMITH, JEFFREY		
[标]发明人	SCOTT J STEPHEN SMITH JEFFREY		
发明人	SCOTT, J., STEPHEN SMITH, JEFFREY		
IPC分类号	A61B17/10 A61B17/04		
CPC分类号	A61B17/0218 A61B17/0401 A61B17/0466 A61B17/0482 A61B17/0487 A61B17/062 A61B17/0643 A61B17/083 A61B2017/0225 A61B2017/0417 A61B2017/0448 A61B2017/0461 A61B2017/0464 A61B2017/0496 A61B2017/06057 A61B2017/06071 A61B2017/0647		
其他公开文献	EP2750613B1 EP2750613A4		
外部链接	Espacenet		

摘要(译)

包括柔性长度的绳索和位于绳索的相对两端并且在绳索的中间位置处的三个组织连接器的设备被设计成通过腹腔镜插入腹壁并进入腹腔，并用于首先移动内部器官到远离第二内部器官的位置，其中该装置将第一内部器官保持在该位置而无需进一步手动输入，从而提供对第二内部器官的外科手术通路。