

(19)



(11)

**EP 2 921 121 B1**

(12)

**EUROPEAN PATENT SPECIFICATION**

(45) Date of publication and mention of the grant of the patent:  
**07.09.2016 Bulletin 2016/36**

(51) Int Cl.:  
**A61B 17/32** <sup>(2006.01)</sup> **A61B 17/34** <sup>(2006.01)</sup>  
**A61B 90/92** <sup>(2016.01)</sup>

(21) Application number: **15163037.3**

(22) Date of filing: **01.10.2004**

(54) **BLADELESS OPTICAL OBTURATOR**  
 OPTISCHER OBTURATOR OHNE KLINGE  
 OBTURATEUR OPTIQUE SANS LAME

(84) Designated Contracting States:  
**DE FR GB**

(30) Priority: **03.10.2003 US 508390 P**

(43) Date of publication of application:  
**23.09.2015 Bulletin 2015/39**

(62) Document number(s) of the earlier application(s) in accordance with Art. 76 EPC:  
**12186722.0 / 2 545 864**  
**04793965.7 / 1 670 349**

(73) Proprietor: **Applied Medical Resources Corporation**  
**Rancho Santa Margarita, CA 92688 (US)**

(72) Inventors:

- **Kahle, Henry**  
**Rancho Santa Margarita, CA California 92688 (US)**
- **Strokosz, Arkadiusz A.**  
**Rancho Santa Margarita, CA California 92688 (US)**
- **McGinley, Kimball B.**  
**Rancho Santa Margarita, CA California 92688 (US)**

- **Taylor, Scott V.**  
**Rancho Santa Margarita, CA California 92688 (US)**
- **Johnson, Gary M.**  
**Rancho Santa Margarita, CA California 92688 (US)**
- **Brustad, John R.**  
**Rancho Santa Margarita, CA California 92688 (US)**

(74) Representative: **Dolleymores**  
**9 Rickmansworth Road**  
**Watford, Hertfordshire WD18 0JU (GB)**

(56) References cited:

<b>EP-A2- 1 074 224</b>	<b>WO-A1-00/18306</b>
<b>WO-A1-01/01847</b>	<b>WO-A1-01/01871</b>
<b>WO-A1-94/11040</b>	<b>WO-A1-03/026512</b>
<b>WO-A2-02/41795</b>	<b>WO-A2-96/01074</b>
<b>WO-A2-03/096879</b>	<b>DE-U1- 29 503 750</b>
<b>US-A- 4 607 619</b>	<b>US-A- 4 959 067</b>
<b>US-A- 5 562 696</b>	<b>US-A- 5 569 291</b>
<b>US-A- 5 738 628</b>	<b>US-A- 5 817 061</b>
<b>US-A- 5 865 809</b>	<b>US-B1- 6 228 059</b>

**EP 2 921 121 B1**

Note: Within nine months of the publication of the mention of the grant of the European patent in the European Patent Bulletin, any person may give notice to the European Patent Office of opposition to that patent, in accordance with the Implementing Regulations. Notice of opposition shall not be deemed to have been filed until the opposition fee has been paid. (Art. 99(1) European Patent Convention).

## Description

### BACKGROUND OF THE INVENTION

#### Field of the Invention

**[0001]** This invention generally relates to trocar systems including obturators and, more specifically, to blunt tip obturators having hollow shafts for insertion of optical instruments.

#### Discussion of the Prior Art

**[0002]** WO03/026512 describes an obturator for wedging through muscle fiber to cut through the abdominal cavity, that the tip of the obturator can be clear and used with a laparoscope to monitor insertion and that the obturator could also be used as an insufflation needle to administer an insufflation gas. The preamble of appended claim 1 is based on this disclosure. WO96/01074 discusses an apparatus for making additional incisions in laparoscopic surgery, and US5,569,291 is directed towards a surgical penetration and dissection instrument.

**[0003]** Trocar systems have been of particular advantage in facilitating less invasive surgery across a body wall and within a body cavity. This is particularly true in abdominal surgery where trocars have provided a working channel across the abdominal wall to facilitate the use of instruments within the abdominal cavity.

**[0004]** The trocar systems of the past typically included a cannula, which provides the working channel, and an obturator which is used to place the cannula across the abdominal wall. The obturator is inserted into the working channel of the cannula and then pushed through the abdominal wall with a penetration force of sufficient magnitude resulting in penetration of the abdominal wall. Once the cannula is in place, the obturator can be removed.

**[0005]** Obturators have been developed with an attempt to reduce the penetration force of the abdominal wall. For example, sharp blades, sharp edges and piercing points have typically been used to enable the obturator to cut or pierce its way through the abdominal wall. While the sharp blades, sharp edges and piercing points have facilitated a reduced penetration force, they have also caused larger trocar site defects. These trocar site defects may have to be sutured closed resulting in increased operating room costs and procedural time. Moreover, once the abdominal wall has been penetrated, the sharp blades, sharp edges and piercing points of the obturator may still cause damage to the vessels and organs that lie within the peritoneal cavity. For example, the blades on the obturators that serve to cut tissue during insertion may also cut vessels or puncture organs that may result in patient injury or surgical complications.

**[0006]** In some cases, shields have been provided with the obturators in order to sense penetration of the abdominal wall and immediately shield the sharp blades,

edges or piercing points. These shielding systems are typically complex and require some time to deploy and, as such, many have not been effective in protecting the vessels and organs against the sharp blades, edges or piercing points. Accordingly, there remains a need in the art for an improved bladeless obturator that separates tissue during insertion through a body wall. Moreover, there is a need for a transparent blunt tip obturator having a hollow shaft to enable insertion of an optical instrument to view the insertion of the obturator through the body wall.

### SUMMARY OF THE INVENTION

**[0007]** The present invention provides the surgical obturator of independent claim 1. The dependent claims specify preferred but optional features.

**[0008]** The invention is directed to a bladeless trocar obturator to separate or divaricate body tissue during insertion through a body wall. The distal tip of the bladeless obturator is constructed of a transparent material to enable visualization of tissue during the insertion of the obturator through the body wall. The bladeless obturator is configured to enable the insertion of a conventional laparoscope which typically includes an imaging element and fiber optic light fibers. During use, the bladeless obturator is first inserted into and through a trocar seal and cannula. A conventional laparoscope is then inserted into the proximal end of the bladeless obturator and advanced to the distal tip of the obturator. An endoscopic video camera is attached to the proximal end of the laparoscope and the bladeless trocar system is then axially advanced by the surgeon through the body wall, the surgeon can visually observe the tissue as it is being separated via a video monitor that is connected to the endoscopic video camera.

**[0009]** In one aspect, the obturator of the invention comprises a shaft extending along an axis between a proximal end and a distal end; and a bladeless tip disposed at the distal end of the shaft and having a generally tapered configuration with an outer surface, the outer surface extending distally to a blunt point with a pair of side sections having a common shape and being separated by at least one intermediate section, wherein each of the side sections extends from the blunt point radially outwardly with progressive positions proximally along the axis, and the shaft is sized and configured to receive an optical instrument having a distal end to receive an image of the body tissue. With this aspect, the tapered configuration facilitates separation or spreading of different layers of the body tissue and provides proper alignment of the tip between the layers. The side sections include a distal portion and a proximal portion, the distal portion of the side sections being twisted radially with respect to the proximal portion of the side sections. The intermediate section includes a distal portion and a proximal portion, the distal portion of the intermediate section being twisted in a first radial direction and the proximal portion

of the intermediate section being twisted in a second radial direction opposite the first radial direction.

**[0010]** The bladeless tip is formed from a transparent material or a translucent material. The bladeless tip can be formed from a plastic material or a glass material. The plastic material can be at least one of polycarbonate, polyphenylsulfone, polyetherimide, acrylic, and polyvinyl chloride. The bladeless obturator can be constructed such that at least one of the shaft and the tip is formed from a reusable or a disposable material. The reusable material can be a metallic material or an autoclavable polymer. The bladeless tip can be generally hollow or substantially solid to receive the distal end of the optical instrument. The bladeless tip can also be solid. The bladeless tip can further comprise at least one portion that is marked differently from the rest of the tip to serve as an indicator, for example, of depth as the tip is being inserted into the body tissue. The bladeless tip is shaped and configured to receive the distal end of the optical instrument having an angled or non-angled lens. The bladeless tip can further comprise a ledge to provide proper positioning of the distal end of the optical instrument having an angled or non-angled lens. The bladeless tip can further comprise a bulbous section to accommodate the distal end of the angled lens optical instrument. The bladeless tip can be further coated or formed from a soft elastomeric material. The shaft and the tip can be connected together by adhesive bonding, ultrasonic welding, snap-fitting, with a shrink tube, or by overmolding the tip over the shaft. The bladeless tip can further comprise a cutout section to provide the distal end of the optical instrument with direct vision of the body tissue.

**[0011]** The bladeless obturator can further comprises a lock disposed at the proximal end of the shaft to frictionally lock the optical instrument in an axial position in the shaft. The lock operates to prevent the optical instrument from moving axially relative to the shaft while allowing the optical instrument to rotate freely about the shaft. The lock can be constructed from a plastic material including polycarbonate. The lock can be a multi-finger collet having an inner diameter smaller than an outer diameter of the optical instrument wherein the fingers of the collet spread open during insertion of the optical instrument providing frictional engagement with the outer diameter of the optical instrument. The lock can further comprise a camming member to constrict the optical instrument in the axial position relative to the shaft. The camming member may be a horizontal or vertical camming member. In another aspect, the lock can further comprise a locking collar to rotationally lock the optical instrument. In yet another aspect, the lock can further comprise a locking nut and thread that frictionally engage the optical instrument in the axial position relative to the shaft, or an elastomeric element that facilitates frictional engagement with the optical instrument in the axial position relative to the shaft.

**[0012]** The bladeless obturator can further comprises a cap disposed at the proximal end of the shaft. The cap

may further comprise a handle.

**[0013]** A surgical obturator adapted to separate body tissue is disclosed comprising a shaft extending along an axis between a proximal end and a distal end; and a bladeless tip disposed at the distal end of the shaft having a tapered surface forming proximally into an outer surface, the outer surface including a pair of generally opposed sections, wherein the outer surface has a generally geometric shape in progressive radial cross-sections from a distal cross-section to a proximal cross-section, wherein the pair of generally opposed sections of the outer surface appears as a pair of lines in each of the progressive radial cross-sections, wherein at least one of the pair of lines becomes more arcuate in the progressive radial cross-sections, and wherein the shaft is sized and configured to receive an optical instrument having a distal end to receive an image of the body tissue. With this aspect, the area of the geometric shape increases along the progressive radial cross-sections.

**[0014]** A surgical obturator adapted to separate body tissue is disclosed comprising a shaft having a proximal end and a distal end; and a transparent bladeless tip disposed at the distal end of the shaft having a tapered surface forming proximally into an outer surface, the outer surface extending distally to a blunt point, wherein the shaft is sized and configured to receive an optical instrument having a distal end to receive an image of the body tissue.

**[0015]** In yet another aspect, an optical separator adapted to receive an image of a body tissue and to separate the body tissue is disclosed comprising an optical instrument having a proximal end and a distal end; and a bladeless tip removably attached at the distal end of the optical instrument and having a generally tapered configuration with an outer surface, the outer surface extending distally to a blunt point.

**[0016]** These and other features of the invention will become more apparent with a discussion of the various embodiments in reference to the associated drawings.

#### DESCRIPTION OF THE DRAWINGS

**[0017]** The accompanying drawings, which are included in and constitute a part of this specification, illustrate the embodiments of the invention and, together with the description, explain the features and principles of the invention. In the drawings:

FIGS. 1A and 1B illustrate side views of a trocar system including a cannula with associated valve housing, and an obturator with a blunt tip extending through the working channel of the cannula to facilitate placement across the abdominal wall;  
 FIG. 2 is a side elevation view of the blunt tip of the obturator of the invention;  
 FIG. 3 is a side elevation view of the blunt tip taken along line 3-3 of FIG. 2;  
 FIG. 4 is an end view taken along line 4-4 of FIG. 2;

FIG. 5 is a radial cross-section view taken along line 5-5 of FIG. 2;  
 FIG. 6 is a radial cross-section view taken along line 6-6 of FIG. 2;  
 FIG. 7 is a radial cross-section view taken along line 7-7 of FIG. 2;  
 FIG. 8 is a radial cross-section view taken along line 8-8 of FIG. 2;  
 FIG. 9 is a radial cross-section view taken along line 9-9 of FIG. 2;  
 FIG. 10 is a schematic view illustrating each of the FIGS. 4-9 superimposed to facilitate an understanding of the blunt tip and its twisted configuration;  
 FIG. 11 illustrates a side view of a bladeless obturator having a tip formed as a blunt tapered shape;  
 FIG. 12 illustrates a side view of a bladeless obturator having a tip formed as a pyramidal shape;  
 FIG. 13 illustrates a side view of a bladeless obturator having a fully radiused tip;  
 FIGS. 14 and 15 illustrate a side view and a cross-section view, respectively, of the trocar system of FIGS. 1A and 1B and further illustrating the insertion of a laparoscope;  
 FIG. 16 illustrates a side view of a bladeless obturator having a bulbous tip;  
 FIG. 17 illustrates a side view of a bladeless obturator having a tip with a cutout section;  
 FIG. 18 illustrates a side view of a bladeless obturator having a shaft with a cutout section;  
 FIG. 19 illustrates a side view of a bladeless obturator and a cover for the cutout section of the shaft of FIG. 18;  
 FIGS. 20 and 21 illustrate side views of a bladeless obturator having a laparoscope lock;  
 FIGS. 22 and 23 illustrate side views of a bladeless obturator including a cap with pistol-grip handle;  
 FIGS. 24 and 25 illustrate the locking mechanism between the bladeless obturator and the trocar seal;  
 FIGS. 26 and 27 illustrate the release mechanism between the bladeless obturator and the trocar seal;  
 FIG. 28 illustrates a top view of a laparoscope lock of the invention comprising a multiple-finger collet;  
 FIG. 29 illustrates an optical instrument having a transparent bladeless tip;  
 FIGS. 30 and 31 illustrate a top view and a side view, respectively, of a laparoscope lock of the invention comprising a camming member;  
 FIGS. 32 and 33 illustrate a top view and a side view, respectively, of a laparoscope lock comprising a clamping member;  
 FIGS. 34 and 35 illustrate a top view and a side view, respectively, of a laparoscope lock of the invention comprising a locking collar; and  
 FIGS. 36 and 37 illustrate a top view and a side view, respectively, of a laparoscope lock comprising a locking nut and thread.

## DESCRIPTION OF THE INVENTION

**[0018]** A trocar system is illustrated in FIG. 1 and is designated by reference numeral 10. This system includes a cannula 12, defining a working channel 14, and a valve housing 16. The system 10 also includes an obturator 18 having a shaft 21 extending along an axis 23. A handle 25 is disposed at a proximal end of the shaft 21 while a blunt tip 27 is disposed at a distal end of the shaft 21. The shaft 21 of the obturator 18 is sized and configured for disposition within the working channel 14 of the cannula 12. With this disposition, the obturator 18 can be placed across a body wall such as the abdominal wall to provide the cannula 12 with access across the wall and into a body cavity, such as the peritoneal or abdominal cavity. The blunt tip 27 serves to direct the obturator 18 through the abdominal wall and the peritoneum, and can be removed with the obturator 18 once the cannula 12 is operatively disposed with the working channel 14 extending into the abdominal cavity. The diameter of the shaft 21 can range from about 3 mm to about 20 mm and is designed to fit within a trocar seal and the cannula 12.

**[0019]** In accordance with the present disclosure, the tip 27 is provided with a blunt tip configuration. The blunt tip 27 takes into account the anatomical configuration of the abdominal wall with an improved structural design and method of insertion. To fully appreciate these aspects, it is helpful to initially discuss the anatomy associated with the abdominal wall. The abdominal wall typically includes a skin layer and a series of muscle layers, in addition to fat and fascia. The muscle layers are each defined by muscle fibers that extend generally parallel to each other in a direction that is different for each of the layers. For example, fibers of a first muscle layer and a second muscle layer may extend in directions that are generally 90 degrees off of each other.

**[0020]** Having noted the directional nature of the muscle fibers, it can be appreciated that such a structure may be separated or divaricated by an obturator having a blunt tip. The blunt tip may also include a twisted rectangular configuration to facilitate movement between the muscle fibers and layers. That is, the blunt tip is capable of being moved generally parallel to and between the fibers associated with a particular muscle layer.

**[0021]** As described earlier, the fibers of the muscle layers may be oriented at different angles to each other such that proper alignment of the tip 27 for separation of one layer may not necessarily result in proper alignment for separation of the next layer. For at least this reason, the obturator 18 has a blunt tip 27 to direct the obturator 18 through the different layers and a rectangular configuration that is twisted slightly so that separation of a first layer begins to rotate the distal end of the blunt tip 27 into proper orientation for separation of the next layer.

**[0022]** The twisted configuration of the blunt tip 27 also causes the blunt tip 27 to function, for example, with the mechanical advantage of a screw thread. With this con-

figuration, an exemplary method of placement requires that the user grip the handle 25 of the obturator 18 and twist it about the axis 23. This twisting motion in combination with the screw configuration of the blunt tip 27 converts radial movement into forward movement along the axis 23. Thus, the user applies both a forwardly directed force as well as a radial force to move the trocar system 10 in a forward direction.

**[0023]** The twisted configuration of the blunt tip 27 is most apparent in the side elevation views of FIGS. 2 and 3. In this example, the blunt tip 27 comprises generally of eight surfaces: two opposing surfaces 50 and 52, separated by two side surfaces 54 and 56, two end surfaces 58 and 59, a generally tapered surface 60 formed in surfaces 50 and 52 around axis 23 and extending beyond end surfaces 58 and 59, and a blunt surface 62.

**[0024]** The surfaces 50 and 52, side surfaces 54 and 56, and tapered surface 60 generally define the cross-section of the blunt tip 27 from blunt surface 62 to proximal end 61. This configuration can best be appreciated with reference to the cross-section views of FIGS. 4-9. In FIG. 4, the distal end of the blunt tip 27 is shown with a circle 64 having the smallest circular area and a rectangle 63 having the greatest length-to-width ratio. The rectangle 63 has a twisted, S-shaped configuration at end surfaces 58 and 59.

**[0025]** As views are taken along progressive proximal cross-sections, it can be seen that the circle 64 becomes larger and the rectangle 63 becomes less twisted, and the width increases relative to the length of the rectangle 63. The spiral nature of the blunt tip 27 is also apparent as the circle 64 and rectangle 63 move counterclockwise around the axis 23. This is perhaps best appreciated in a comparison of the circle 64 and the rectangle 63 in FIG. 6 relative to that in FIG. 5. With progressive proximal positions, the circle 64 begins to expand with increasing circular area and the rectangle 63 begins to widen with a reduction in the ratio of length to width. The long sides of the rectangle 63 also tend to become more arcuate as they approach a more rounded configuration most apparent in FIGS. 8 and 9. That is, the circle 64 and the rounded rectangle 63 become more circular with progressive proximal positions. Furthermore, the circle 64 expands at a lesser rate than the rectangle 63, which eventually absorbs the circle 64 as shown in FIGS. 8 and 9. In these figures, it will also be apparent that the rotation of the rectangle 63 reaches a most counterclockwise position and then begins to move clockwise. This is best illustrated in FIGS. 7-9. This back and forth rotation results from the configuration of the side surfaces 54 and 56, which in general are U-shaped as best illustrated in FIGS. 2 and 3.

**[0026]** The ratio of the length to width of the rectangle 63 is dependent on the configuration of the side surfaces 54 and 56, which define the short sides of the rectangle 63 as well as the configuration of the surfaces 50 and 52, which define the long sides of the rectangle 63. Again with reference to FIGS. 2 and 3, it can be seen that the

side surfaces 54 and 56 are most narrow at the end surfaces 58 and 59. As the side surfaces 54 and 56 extend proximally, they reach a maximum width near the point of the most counterclockwise rotation, shown generally in FIG. 8, and then reduce in width as they approach the proximal end 61. Along this same distal to proximal path, the surfaces 50 and 52 transition from a generally flat configuration at the end surfaces 58 and 59 to a generally rounded configuration at the proximal end 61.

**[0027]** In the progressive views of FIGS. 5-7, the circle 64 is further designated with a lower case letter a, b or c, respectively; similarly, the rectangle 63 is further designated with a lower case letter a, b, c, d or e, respectively, in FIGS. 5-9. In FIG. 10, the circles 64, 64a-64c and the rectangles 63, 63a-63e are superimposed on the axis 23 to show their relative sizes, shapes and angular orientations.

**[0028]** With a generally tapered configuration at the distal end and a rectangular configuration at a distal portion of the tip, the tip 27 appears much like a flathead screwdriver having a blunt tip. More particularly, the tip 27 includes a tapered structure extending outward from the end surfaces 58 and 59 that serves to direct the obturator 18 through the tissue fibers.

**[0029]** In one aspect, the lengths of the end surfaces 58 and 59 may be aligned parallel with the fibers of each muscle layer. A simple back and forth twisting motion of the blunt tip 27 tends to separate the fibers along natural lines of separation, opening the muscle layer to accept the larger diameter of the cannula 12. Once the first layer is substantially separated, the tapered and twisted configuration of the blunt tip 27 directs and turns the rectangle 63 more into a parallel alignment with fibers in the next layer. Again, the blunt tip 27 and the twisting or dithering motion facilitates an easy separation of the fibers requiring a significantly reduced insertion force.

**[0030]** The device of this disclosure facilitates a unique method of separating tissue and can be applied to any object with a blunt tip and generally flat sides. In particular, it can be operated by rotating in alternating clockwise and counterclockwise directions while applying a downward force. When rotating in alternating directions, the tissue is moved apart and a larger opening is created for a profile of greater cross-sectional area to follow. This process continues safely as the device enters the peritoneal cavity and moves to its operative position.

**[0031]** When the cannula 12 is ultimately removed, the size of the opening left in the tissue is minimal. Importantly, this opening is left with a small defect that does not require suturing due to a dilating effect caused by the mere separation of fibers. Since there are no sharp blades, sharp edges or piercing points to cut tissue fibers, the healing process is shortened. It is appreciated that in other aspects of the disclosure, the tip of the bladeless obturator 18 can be formed as a generally tapered shape 27a with a blunt distal end as illustrated in FIG. 11, as a pyramidal shape 27b with a blunt distal end and blunt edges as illustrated in FIG. 12, and as a fully radiused

tip 27c for insertion through flaccid tissue or an existing body orifice such as the urethra as illustrated in FIG. 13.

**[0032]** The blunt tip 27 can be formed from a translucent or a transparent material. The blunt tip 27 can be formed from a plastic material or a glass material. In one aspect, the shaft 21 and the tip 27 are formed from a transparent polycarbonate material.

**[0033]** Referring to FIGS. 14 and 15, the bladeless obturator 18 is designed to accommodate the insertion of a conventional laparoscope 30. In particular, the shaft 21 of the bladeless obturator 18 is hollow to allow for the insertion of the laparoscope 30 at an opening 32. The shaft 21 is sized and configured to allow the laparoscope 30 to slide within proximity of the tip 27 thus providing a viewing area through the tip 27. An endoscopic video camera (not shown) is typically connected to the laparoscope 30 and this combination is connected to a video monitor. By enabling the positioning of the conventional laparoscope 30 within the tip 27 of the bladeless obturator 18, it is possible to visually observe body tissue as it is being separated by the trocar system 10. Visualization of body tissue as it is being separated by the trocar system 10 allows a surgeon to monitor the advancement of the trocar system 10 and to avoid traumatizing vessels or organs. For example, during a laparoscopic cholecystectomy, a trocar is usually placed through the umbilicus of the patient. The placement of this trocar is typically performed in a blind fashion in that the surgeon cannot see where the tip of the trocar is as it is advanced through the abdominal wall and into the abdominal cavity of the patient. This results in a high degree of risk that the trocar may be inadvertently advanced too far into the abdomen of the patient resulting in trauma to vital organs and/or vessels. By providing a trocar system with visualization properties, this risk is diminished as the surgeon is better able to determine when the trocar has traversed the abdominal wall.

**[0034]** It is appreciated that the tip 27 may be generally hollow or it may be substantially solid to receive the distal end of the laparoscope 30. In another aspect, the tip 27 may be a solid tip. The tip 27 may further comprise at least one portion that is marked differently from the rest of the tip to serve as an indicator, for example, of depth as the tip 27 is being inserted into the body tissue. The at least one portion may be opaque or marked with a different color from the rest of the tip 27.

**[0035]** The shaft 21 and the tip 27 of the bladeless obturator 18 can accommodate a laparoscope with a non-angled lens, also known as a 0° laparoscope. The shaft 21 and the tip 27 can also accommodate a laparoscope with an angled lens such as a 30° laparoscope. The tip 27 is designed such that when either a 0° laparoscope or a 30° laparoscope is inserted therein, the lens of the laparoscope extends beyond a distal edge 36 of the cannula 12 thereby providing a clear and unobstructed view through the tip 27. The tip 27 further includes a ledge 39 that properly engages either the 0° laparoscope or the 30° laparoscope.

**[0036]** It should be noted that conventional trocars with visualization properties typically require a 0° laparoscope for insertion of the trocars and a 30° laparoscope for viewing anatomical structures during the remainder of the laparoscopic procedure. This requires the operating staff to provide two laparoscopes for the laparoscopic procedure, which increases hospital inventory costs and surgical preparation costs relating to cleaning and sterilization of the laparoscopes. In addition, because two laparoscopes are required for the laparoscopic procedure, there is additional operating room time required during the surgical procedure to transfer the endoscopic video camera from the 0° laparoscope to the 30° laparoscope which results in increased operating room costs for the hospital.

**[0037]** The bladeless obturator provides a clear unobstructed view of body tissue through either a 0° or a 30° laparoscope, therefore obviating the need for a hospital to carry the additional inventory required to provide two laparoscopes for each laparoscopic surgical procedure, and obviating the need for a hospital to clean and sterilize a second laparoscope for each laparoscopic surgical procedure, and obviating the need to transfer the endoscopic video equipment from one laparoscope to the other laparoscope during each laparoscopic surgical procedure. Referring to FIG. 16, the shaft 21 may include a tip with a bulbous section 27d to better accommodate the distal end of the angled lens laparoscope. By adding the bulbous section 27d, the distal end of the angled lens laparoscope would be closer to the tip of the obturator thereby improving visualization.

**[0038]** In yet another aspect, the bladeless obturator can include integral fiber optic light fiber elements and an integral imaging element within the shaft and the tip of the obturator. The bladeless obturator with integral imaging means can be formed of reusable or disposable materials.

**[0039]** The bladeless obturator 18 can be constructed as a single component or as multiple components such as the shaft 21 and the tip 27. If the obturator 18 is constructed as a single component, then it can be formed from either disposable or reusable materials. If the obturator 18 is constructed as two or more components, then each component can be formed from either disposable or reusable materials as desired for a particular configuration. In one aspect, the obturator 18 is constructed from a single reusable material such as metal (e.g., stainless steel) or an autoclavable polymer to facilitate re-sterilization. In another aspect, the obturator 18 is formed from a transparent steam sterilizable reusable plastic material such as polyphenylsulfone or polyetherimide. The blunt tip 27 can also be coated or otherwise constructed from a soft elastomeric material. In such a case, the material can be a solid elastomer or composite elastomer/polymer.

**[0040]** It is further appreciated that the shaft 21 can be formed so as to be partially or fully flexible. With this configuration, the obturator 18 can be inserted through a

passageway containing one or more curves of virtually any shape. A partially or fully flexed obturator 18 can then be used with a flexible cannula 12 allowing greater access to an associated body cavity.

**[0041]** The obturator 18 can include a separately molded tip 27 and a molded or extruded shaft 21 with the two components, as explained above, comprising of the same material or different materials. The tip 27 can then be attached to the shaft 21 by adhesive bonding, ultrasonic welding, snap-fitting, or with a shrink tube. The tip 27 can also be overmolded over the shaft 21 to mechanically lock the two components together. The tip 27 can be formed from a transparent material such as polycarbonate to enable visualization while the shaft 21 can be formed from either an opaque material or a transparent material. The shaft 21 can also be formed from a metal material.

**[0042]** In another aspect, the obturator 18 can include a disposable tip that is releasably attached to a reusable shaft 21. In this aspect, a new tip 27 can be used for each procedure to provide optimal visualization through the tip 27 of the obturator 18 during each procedure.

**[0043]** Referring to FIG. 17, there is shown a shaft 18e in accordance with another aspect of the disclosure including a cutout section 100e in the tip portion 27e that enables direct visualization of the body tissue as the tip 27e separates tissue fibers. By providing an obturator with cutout sections, the reflection of light from the laparoscope is minimized and the visibility of the tissue through the laparoscope is improved as compared to a design where visualization occurs through a plastic or glass window. It is appreciated that the shaft 21 e can include a single or a plurality of cutouts 100e in the tip 27e or along the shaft of the obturator.

**[0044]** Referring to FIG. 18, there is shown a shaft 21f in accordance with another aspect of the disclosure having a cutout portion 100f along the axial axis of the shaft 21f. The shaft 21f has a cross-section of about ½-circle to about ¾-circle and the cutout portion 100f has a cross-section of about ½-circle to about ¾-circle. An advantage of this aspect is the wall of the shaft 21f can be a little thicker as a result of the cutout section, which makes injection molding of the shaft easier.

**[0045]** Referring to FIG. 19, there is shown a cover 102f that can be attached over the cutout portion 100f of the ½-circle shaft 21f as shown in FIG. 18. In particular, a polycarbonate cover also with a ½-circle shaped cross-section can be attached to the shaft to form a tubular cross-section. An advantage of molding the tubular shaft 21f in two pieces is increased manufacturability of the shaft 21f. The cover 102f can be attached to the shaft 21f with an adhesive bond, an ultrasonic weld, a snap-fit, or with a shrink tube.

**[0046]** In another aspect, the obturator can be formed from two clam-shell components each including one-half of the shaft and tip configuration along the axial axis of the obturator. The two components can then be affixed together using an adhesive bond, an ultrasonic weld, an

outer shrink tube, or a snap fit.

**[0047]** Referring to FIGS. 20 and 21, another feature of the bladeless obturator 18 is it is designed to frictionally lock the laparoscope 30 in place using a laparoscope lock 40, which can be formed within the handle 25. More specifically, the laparoscope lock 40 prevents the laparoscope 30 from moving axially relative to the shaft 21 of the obturator 18 during handling within the sterile field and during insertion through a body wall but enables the laparoscope 30 to rotate freely relative to the shaft 21. This rotation of the lock 40 enables the trocar system 10 to be twisted during insertion into and through the abdominal wall while maintaining the laparoscope 30 in a fixed rotational position that provides for a stable viewing image on the video monitor.

**[0048]** The conventional obturators with visualization properties include means for locking the laparoscope in place but these obturators lock the laparoscope both axially and rotationally. A drawback of the conventional devices is the viewing image on the video monitor is unstable if the trocar is twisted during insertion. More specifically, with prior art obturator laparoscope locks, if the trocar is twisted back and forth in a clockwise and counter-clockwise fashion, the laparoscope also moves clockwise and counter-clockwise with the trocar resulting in an oscillating and disorienting viewing image on the video monitor. The laparoscope lock 40 improves visualization and enables a more precise placement of the trocar within the body tissue and across the body wall as compared to obturators of the prior art while preventing inadvertent axial movement of the laparoscope during handling and use.

**[0049]** In another aspect of the disclosure as illustrated in FIGS. 20 and 21, the bladeless obturator 18 further comprises a cap 42 that can be snap-fitted onto the proximal end of the obturator shaft 21, after which the laparoscope lock 40 can be snap-fitted onto the end of the cap 42. Both the cap 42 and the lock 40 can be formed of a plastic material such as polycarbonate. The obturator cap 42 can be provided with and without a pistol-grip handle. The handled version of the bladeless obturator provides a pistol-grip to ease insertion of the trocar system as illustrated in FIGS. 22 and 23. The pistol-grip handle is designed to nest into the handle on the trocar seal to prevent excessive flexure of the handle during insertion of the trocar as illustrated in FIG. 23. More particularly, the handled bladeless obturator includes three components comprising of an obturator shaft 21 b, an obturator cap 42b having a pistol-grip handle 26b, and a laparoscope lock 40b, all of which can be injection molded out of polycarbonate. The pistol-grip handle 26b can be formed with two components frictionally fitted together with, for example, interference pins. The interference pins can be fitted into holes in the handle 26b to affect a frictional lock between the two components.

**[0050]** Referring to FIG. 24, the bladeless obturator 18 is designed to releasably attach to a trocar seal 17 via two cantilever snap-fits 70a, 70b. As the obturator 18 is

inserted into the trocar seal 17 and cannula 12, the snap-fits 70a, 70b passively engage the trocar seal 17 and serve to axially lock the obturator 18 to the trocar seal 17 and cannula 12 (FIGS. 24 and 25). To release the obturator 18 from the trocar seal 17 and cannula 12, outboard tabs 72a, 72b on the obturator cap 42 are depressed inwardly and the obturator 18 is then free to be slidably removed as illustrated in FIGS. 26 and 27. Referring back to FIGS. 20 and 21, the bladeless obturator 18 includes axial key members 74 at its proximal end which are designed to mate with axial keyways on the trocar seal 17. As the bladeless obturator 18 is inserted into the trocar seal 17 and cannula 12, the obturator 18 is rotated slightly to align the axial key members 74 with the axial keyways and then advanced until the snap-fits 70a, 70b engage the trocar seal 17. The axial key members 74 serve to rotationally lock the obturator 18 to the trocar seal 17.

**[0051]** Referring to FIG. 28, there is shown another example of the laparoscope lock 40c comprising a multiple-finger collet 80c comprising a plurality of fingers 82c. The multiple-finger collet 80c has an inner diameter that is smaller than the outer diameter of the laparoscope. The fingers 82c of the collet 80c spread open during insertion of the laparoscope providing frictional engagement with the outer diameter of the laparoscope. The laparoscope lock 40c is free to rotate on an obturator cap 42c, and allows the laparoscope to freely rotate relative to the shaft of the bladeless obturator.

**[0052]** Referring back to FIGS. 20 and 21, the obturator shaft 21 of the bladeless obturator 18 can be configured with a barb 76 at its proximal end. The barb 76 is vertically slotted to enable the shaft 21 to flex during assembly. The obturator shaft 21 may also include a plurality of keys (not shown) near its proximal end. The obturator cap 42 is configured to axially slide over the barb 76 on the obturator shaft 21 to affect a one-way snap-fit lock between the two components. This snap-fit prevents the removal of the obturator cap 42 from the obturator shaft 21. The obturator cap 42 may further include keyways (not shown) that engage the keys on the obturator shaft 21 to rotationally index the components together. The obturator cap 42 may further include a second barb (not shown) at its proximal end. The laparoscope lock 40 may include a plurality of tabs (not shown) that are designed to spread and axially slide over the second barb on the obturator cap 42 to affect a one-way snap-fit lock between the obturator cap 42 and the laparoscope lock 40. This snap-fit prevents the axial removal of the laparoscope lock 40 from the obturator cap 42. The laparoscope lock 40 is free to rotate relative to the obturator cap 42.

**[0053]** Referring to FIG. 29, there is shown another aspect of the disclosure of a laparoscope 30a having a tip 33a configured similar to that of the tip 27 of the bladeless obturator 18 described above, the tip 33a being adapted to snap-fit or frictionally engage the end of the laparoscope 30a. With this configuration, the combination of the tip 33a and the laparoscope 30a serve to form an optical obturator having a blunt tip. Once the trocar is

inserted and the laparoscope removed from the trocar seal and cannula, the bladeless tip 33a can then be removed from the laparoscope 30a. The bladeless tip 33a can be formed from either a disposable or reusable transparent material. The bladeless tip 33a can be temporarily or permanently affixed to the scope 30a by any of the known methods of attaching the two components together as explained above.

**[0054]** Referring to FIGS. 30 and 31, there is shown a laparoscope lock 40d in accordance with another example of the disclosure including an active lock comprising a camming member 43d. With this type of lock, the laparoscope would first be inserted into the shaft of the obturator and then the lock 40d would be activated to lock the laparoscope in an axial position relative to the shaft. The lock 40d can either rotate freely to enable the laparoscope to rotate freely relative to the shaft or the lock 40d can be rotationally fixed to prevent the laparoscope from rotating relative to the shaft. In another aspect as illustrated in FIGS. 32 and 33, a lock 40e can include an active lock comprising a clamping member 45e. With this type of lock, the laparoscope would first be inserted into the shaft of the obturator and then the lock would be activated to lock the laparoscope in an axial position relative to the shaft. The lock 40e can either rotate freely to enable the laparoscope to rotate freely relative to the shaft or the lock 40e can be rotationally fixed to prevent the laparoscope from rotating relative to the shaft.

**[0055]** Referring to FIGS. 34 and 35, there is shown a lock 40f in accordance with another example of the disclosure including an active lock comprising a locking collar 46 positioned eccentrically with respect to the axis of the obturator so that as the locking collar 46 is turned, a frictional engagement with the laparoscope is affected. The laparoscope would first be inserted into the locking collar 46 and the shaft of the obturator, the locking collar 46 can then be turned to frictionally engage the laparoscope. The laparoscope lock 40f can either rotate freely to enable the laparoscope to rotate freely relative to the shaft or the laparoscope lock 40f can be rotationally fixed to prevent the laparoscope from rotating relative to the shaft.

**[0056]** In another aspect of the disclosure as illustrated in FIGS. 36 and 37, there is shown a laparoscope lock 40g including an active lock comprising of a locking nut 48 and a thread. The threaded portion of the lock 40g has flexible elements similar to those on a collet. The laparoscope would first be inserted into the threaded portion of the lock 40g and the nut then rotated clockwise to collapse the flexible elements to frictionally engage the laparoscope. To release the laparoscope, the nut is rotated counter-clockwise.

**[0057]** In another aspect, the laparoscope lock can include a lock that includes an elastomeric element. The addition of the elastomeric element can enhance the frictional engagement with the laparoscope. An example of such an elastomeric element is a silicone O-ring sized with an inside diameter smaller than the outside diameter

of the laparoscope. The laparoscope lock can either rotate freely to enable the laparoscope to rotate freely relative to the shaft or the laparoscope lock can be rotationally fixed to prevent the laparoscope from rotating relative to the shaft.

**[0058]** In yet another aspect, the obturator 18 can also be used as an insufflation needle having a passageway and valve to administer carbon dioxide or other insufflation gas to the peritoneal cavity. The obturator 18 can also be used with an insufflation needle cannula in which case removal of the obturator 18 upon entry would allow for rapid insufflation of the peritoneal cavity.

**[0059]** In the invention, the bladeless obturator can be formed with a 2-3 mm outer diameter and has a small thru-hole at its distal end. The bladeless obturator can be used in conjunction with a miniaturized laparoscope to provide initial access into a hollow body cavity. Once access is obtained, the laparoscope can be removed from the bladeless obturator and an insufflation gas such as carbon dioxide can be dispensed through the obturator into the hollow body cavity. The bladeless obturator of the invention also includes holes in the tip portion to enhance the flow of insufflation gases through the obturator. More particularly, the bladeless obturator can be formed with a 2-3 mm outer diameter and used in conjunction with a miniaturized laparoscope to provide initial access into a hollow body cavity. After access is obtained, the bladeless obturator can be removed from the trocar cannula and an insufflation gas such as carbon dioxide can be dispensed through the cannula and into the hollow body cavity.

**[0060]** It will be understood that many modifications can be made to the disclosed embodiments without departing from the scope of the invention, which is defined in appended claim 1. For example, various sizes of the surgical device are contemplated as well as various types of constructions and materials. It will also be apparent that many modifications can be made to the configuration of parts as well as their interaction. For these reasons, the above description should not be construed as limiting the invention, but should be interpreted as merely exemplary of preferred embodiments.

## Claims

1. A surgical access device adapted to separate tissue during insertion through a body wall, comprising:

an obturator (18) including a shaft (21) extending along a longitudinal axis (23) between a proximal end and a distal end; and  
a bladeless tip (27) at the distal end of the shaft (21) and having a generally tapered configuration and constructed of transparent material to enable visualization of tissue during insertion of the obturator through the body wall; wherein the shaft (21) is sized and configured to receive an

optical instrument having a distal end adapted to receive an image of the tissue such that the distal end of the optical instrument is advanced to the tip at the distal end of the shaft; wherein the access device further comprises a cannula (12) the cannula comprising an elongate shaft (21) extending along a longitudinal axis (23) and defining a working channel (14) between an open proximal end and an open distal end; the cannula including a valve housing (16) at the proximal end and a trocar seal (17) located inside the valve housing (16); the cannula (12) being configured to receive the obturator (18) inside the working channel (14) and the obturator to fit within the trocar seal (17); wherein the obturator has a small through-hole at its distal end and has at least one hole in the distal tip (27) wherein the obturator (18) is configured for delivering insufflation gasses through the obturator (18) and out the at least one hole in the distal tip.

2. The surgical access device of Claim 1 wherein the obturator is configured such that insufflation gas can be dispensed through the obturator.
3. The surgical access device of Claim 1 or 2 wherein the optical instrument is a laparoscope and the distal end of laparoscope when inserted extends into the hollow bladeless tip (27).
4. The surgical access device of Claim 1, 2 or 3 wherein the tapered configuration of the bladeless tip facilitates separation or spreading of different layers of the body tissue.
5. The surgical access device of any preceding claim wherein the obturator further comprises a lock disposed at the proximal end of the obturator shaft; the lock is configured to prevent the optical instrument from moving axially relative to the shaft.
6. The surgical access device of any preceding claim further including an elastomeric element disposed at the proximal end of the shaft and configured to frictionally engage the optical instrument inserted into the shaft in the axial position relative to the shaft.
7. The surgical access device of claim 6 wherein the elastomeric element is a O-ring with an inside diameter smaller than the outside diameter of the laparoscope.
8. The surgical access device of any of any preceding claim wherein the bladeless tip has a rounded rectangular shape in radial cross-section of the tip.
9. The surgical access device of any preceding claim

wherein the cannula is connected to obturator (18) such that the obturator (18) does not move axially or rotationally relative to the cannula (12).

10. The surgical access device of any preceding claim wherein the shaft is sized and configured to allow the optical instrument to slide within proximity of the tip to permit viewing through the tip. 5
11. The surgical access device of any preceding claim further includes a lock and the lock is configured to frictionally lock the optical instrument 10
12. The surgical access device of any preceding claim wherein the bladeless tip includes an outer surface with a pair of side sections (50, 52, 54, 56) having a common shape and being separated by at least one intermediate section wherein each of the side sections extends from the blunt point radially outwardly with progressive positions proximally along the axis. 15 20
13. The surgical access device of claim 12 wherein the side sections (50, 52, 54, 56) include a distal portion and a proximal portion; the distal portion of the side sections being twisted radially with respect to the proximal portion of the side sections. 25
14. The surgical access device of claim 12 or 13 wherein the intermediate section includes a distal portion and a proximal portion, the distal portion of the intermediate section being twisted in a first radial direction and the proximal portion of the intermediate section being twisted in a second radial direction opposite the first radial direction. 30
15. The surgical access device of any preceding claim wherein the bladeless tip has a rectangular configuration that is twisted. 35

#### Patentansprüche

1. Ein während der Einführung durch eine Körperwand zum Trennen von Gewebe angepasstes chirurgisches Zugangsgerät, das Folgendes beinhaltet: 45
  - einen Obturator (18), der einen Schaft (21) einschließt, der sich entlang einer Längsachse (23) zwischen einem proximalen Ende und einem distalen Ende erstreckt; und 50
  - eine klingenlose Spitze (27) am distalen Ende des Schafts (21) und die eine im Allgemeinen konisch zulaufende Konfiguration aufweist und aus einem transparenten Material konstruiert ist, um die Sichtbarmachung von Gewebe während des Einführens des Obturators durch die Körperwand zu ermöglichen; 55
  - wobei der Schaft (21) dazu dimensioniert und

konfiguriert ist, ein optisches Instrument zu empfangen, das ein distales Ende aufweist, das zum Empfangen eines Bildes des Gewebes angepasst ist, so dass das distale Ende des optischen Instruments zu der Spitze am distalen Ende des Schafts hin bewegt wird; wobei das Zugangsgerät ferner eine Kanüle (12) beinhaltet, wobei die Kanüle einen länglichen Schaft (21) beinhaltet, der sich entlang einer Längsachse (23) erstreckt und einen Arbeitskanal (14) zwischen einem offenen proximalen Ende und einem offenen distalen Ende definiert; wobei die Kanüle ein Ventilgehäuse (16) an dem proximalen Ende und eine Trokardichtung (17), die sich im Innern des Ventilgehäuses (16) befindet, einschließt; wobei die Kanüle (12) dazu konfiguriert ist, den Obturator (18) innerhalb des Arbeitskanals (14) zu empfangen, und dass der Obturator in die Trokardichtung (17) passt; wobei der Obturator ein kleines Durchgangsloch an seinem distalen Ende aufweist und mindestens ein Loch in der distalen Spitze (27) aufweist, wobei der Obturator (18) dazu konfiguriert ist, Insufflationsgase durch den Obturator (18) und aus dem mindestens einem Loch in der distalen Spitze heraus zu leiten.

2. Das chirurgische Zugangsgerät gemäß Anspruch 1, wobei der Obturator so konfiguriert ist, dass Insufflationsgas durch den Obturator abgegeben werden kann.
3. Das chirurgische Zugangsgerät gemäß Anspruch 1 oder 2, wobei das optische Instrument ein Laparoskop ist und das distale Ende des Laparoscops, wenn es eingeführt ist, sich in die hohle klingenlose Spitze (27) hinein erstreckt. 35
4. Das chirurgische Zugangsgerät gemäß Anspruch 1, 2 oder 3, wobei die konisch zulaufende Konfiguration der klingenlosen Spitze das Trennen oder Ausbreiten verschiedener Schichten des Körpergewebes erleichtert. 40
5. Das chirurgische Zugangsgerät gemäß einem der vorhergehenden Ansprüche, wobei der Obturator ferner eine Arretierung beinhaltet, die am proximalen Ende des Obturatorschafts angeordnet ist; wobei die Arretierung dazu konfiguriert ist, zu verhindern, dass das optische Instrument sich axial im Verhältnis zu dem Schaft bewegt. 45
6. Das chirurgische Zugangsgerät gemäß einem der vorhergehenden Ansprüche, das ferner ein elastomeres Element einschließt, das an dem proximalen Ende des Schafts angeordnet ist und zum Reibeingriff mit dem optischen Instrument, das in der im Verhältnis zu dem Schaft axialen Position in in den 55

Schaft eingeführt ist, konfiguriert ist.

7. Das chirurgische Zugangsgerät gemäß Anspruch 6, wobei das elastomere Element ein O-Ring mit einem Innendurchmesser ist, der kleiner ist als der Außendurchmesser des Laparoscops. 5
8. Das chirurgische Zugangsgerät gemäß einem vorhergehenden Anspruch, wobei die klingenlose Spitze eine abgerundete rechteckige Form im radialen Querschnitt der Spitze aufweist. 10
9. Das chirurgische Zugangsgerät gemäß einem der vorhergehenden Ansprüche, wobei die Kanüle so mit dem Obturator (18) verbunden ist, dass der Obturator (18) sich nicht axial oder rotational im Verhältnis zu der Kanüle (12) bewegt. 15
10. Das chirurgische Zugangsgerät gemäß einem der vorhergehenden Ansprüche, wobei der Schaft dazu dimensioniert und konfiguriert ist, es dem optischen Instrument zu erlauben, in die Nähe der Spitze zu gleiten, um ein Durchsehen durch die Spitze zu gestatten. 20
11. Das chirurgische Zugangsgerät gemäß einem der vorhergehenden Ansprüche, das ferner eine Arretierung einschließt und wobei die Arretierung zum Reibschluss mit dem optischen Instrument konfiguriert ist. 25
12. Das chirurgische Zugangsgerät gemäß einem der vorhergehenden Ansprüche, wobei die klingenlose Spitze eine Außenfläche mit einem Paar von Seitenabschnitten (50, 52, 54, 56) einschließt, die eine gemeinsame Form aufweisen und durch mindestens einen Zwischenabschnitt getrennt sind, wobei jeder der Seitenabschnitte sich von dem stumpfen Punkt radial nach außen mit progressiven Positionen proximal entlang der Achse erstreckt. 30
13. Das chirurgische Zugangsgerät gemäß Anspruch 12, wobei die Seitenabschnitte (50, 52, 54, 56) einen distalen Teil und einen proximalen Teil einschließen; wobei der distale Teil der Seitenabschnitte bezüglich des proximalen Teils der Seitenabschnitte radial verdreht ist. 35
14. Das chirurgische Zugangsgerät gemäß Anspruch 12 oder 13, wobei der Zwischenabschnitt einen distalen Teil und einen proximalen Teil einschließt, wobei der distale Teil des Zwischenabschnitts in einer ersten radialen Richtung verdreht ist und der proximale Teil des Zwischenabschnitts in einer der ersten radialen Richtung entgegengesetzten, zweiten radialen Richtung verdreht ist. 40
15. Das chirurgische Zugangsgerät gemäß einem der 45

vorhergehenden Ansprüche, wobei die klingenlose Spitze eine rechteckige Konfiguration aufweist, die verdreht ist.

## Revendications

1. Dispositif d'accès chirurgical adapté pour séparer un tissu durant l'insertion à travers une paroi corporelle, comprenant : 50

un obturateur (18) comprenant un arbre (21) s'étendant le long d'un axe longitudinal (23) entre une extrémité proximale et une extrémité distale ; et

une pointe sans lame (27) à l'extrémité distale de l'arbre (21) et ayant une configuration généralement effilée et fabriquée en un matériau transparent afin de permettre de visualiser le tissu durant l'insertion de l'obturateur à travers la paroi corporelle ; où l'arbre (21) est dimensionné et configuré pour recevoir un instrument optique ayant une extrémité distale adaptée pour recevoir une image du tissu de telle sorte que

l'extrémité distale de l'instrument optique est avancée vers la pointe à l'extrémité distale de l'arbre ; où le dispositif d'accès comprend en outre une canule (12), la canule comprenant un arbre allongé (21) s'étendant le long d'un axe longitudinal (23) et définissant un canal opérationnel (14) entre une extrémité proximale ouverte et une extrémité distale ouverte ; la canule comprenant un logement de soupape (16) à l'extrémité proximale et un joint d'étanchéité de trocart (17) situé à l'intérieur du logement de soupape (16) ; la canule (12) étant configurée pour recevoir l'obturateur (18) à l'intérieur du canal opérationnel (14) et pour que l'obturateur s'ajuste dans le joint d'étanchéité de trocart (17) ;

où l'obturateur a un petit trou traversant à son extrémité distale et a au moins un trou dans la pointe distale (27), où l'obturateur (18) est configuré pour délivrer des gaz d'insufflation à travers l'obturateur (18) et hors du au moins un trou dans la pointe distale.

2. Dispositif d'accès chirurgical selon la revendication 1, dans lequel l'obturateur est configuré de telle sorte que le gaz d'insufflation peut être distribué à travers l'obturateur. 55
3. Dispositif d'accès chirurgical selon la revendication 1 ou 2, dans lequel l'instrument optique est un laparoscope et l'extrémité distale du laparoscope, lorsque inséré, s'étend dans la pointe creuse sans lame (27).

4. Dispositif d'accès chirurgical selon la revendication 1, 2 ou 3, dans lequel la configuration effilée de la pointe sans lame facilite la séparation ou l'écartement de différentes couches du tissu corporel.
5. Dispositif d'accès chirurgical selon l'une quelconque des revendications précédentes, dans lequel l'obturateur comprend en outre un dispositif de blocage disposé à l'extrémité proximale de l'arbre de l'obturateur ; le dispositif de blocage est configuré pour empêcher le mouvement axial de l'instrument optique par rapport à l'arbre.
6. Dispositif d'accès chirurgical selon l'une quelconque des revendications précédentes comprenant en outre un élément en élastomère disposé à l'extrémité proximale de l'arbre et configuré pour engager par frottement l'instrument optique inséré dans l'arbre dans la position axiale par rapport à l'arbre.
7. Dispositif d'accès chirurgical selon la revendication 6, dans lequel l'élément en élastomère est un joint torique avec un diamètre interne plus petit que le diamètre externe du laparoscope.
8. Dispositif d'accès chirurgical selon l'une quelconque des revendications précédentes, dans lequel la pointe sans lame a une forme rectangulaire arrondie en coupe transversale radiale de la pointe.
9. Dispositif d'accès chirurgical selon l'une quelconque des revendications précédentes, dans lequel la canule est raccordée à l'obturateur (18) de telle sorte que l'obturateur (18) ne se déplace pas axialement ou d'une manière rotative par rapport à la canule (12).
10. Dispositif d'accès chirurgical selon l'une quelconque des revendications précédentes, dans lequel l'arbre est dimensionné et configuré pour permettre à l'instrument optique de glisser à proximité de la pointe afin de permettre la visualisation à travers la pointe.
11. Dispositif d'accès chirurgical selon l'une quelconque des revendications précédentes, qui comprend en outre un dispositif de blocage et le dispositif de blocage est configuré pour bloquer l'instrument optique par frottement.
12. Dispositif d'accès chirurgical selon l'une quelconque des revendications précédentes, dans lequel la pointe sans lame a une surface extérieure avec une paire de sections latérales (50, 52, 54, 56) ayant une forme commune et étant séparées par au moins une section intermédiaire, où chacune des sections latérales s'étend de la pointe émoussée radialement vers l'extérieur avec des positions progressives d'une manière proximale le long de l'axe.
13. Dispositif d'accès chirurgical selon la revendication 12, dans lequel les sections latérales (50, 52, 54, 56) comprennent une partie distale et une partie proximale ; la partie distale des sections latérales étant tordue radialement par rapport à la partie proximale des sections latérales.
14. Dispositif d'accès chirurgical selon la revendication 12 ou 13, dans lequel la section intermédiaire comprend une partie distale et une partie proximale, la partie distale de la section intermédiaire étant tordue dans une première direction radiale et la partie proximale de la section intermédiaire étant tordue dans une deuxième direction radiale opposée à la première direction radiale.
15. Dispositif d'accès chirurgical selon l'une quelconque des revendications précédentes, dans lequel la pointe sans lame a une configuration rectangulaire qui est tordue.

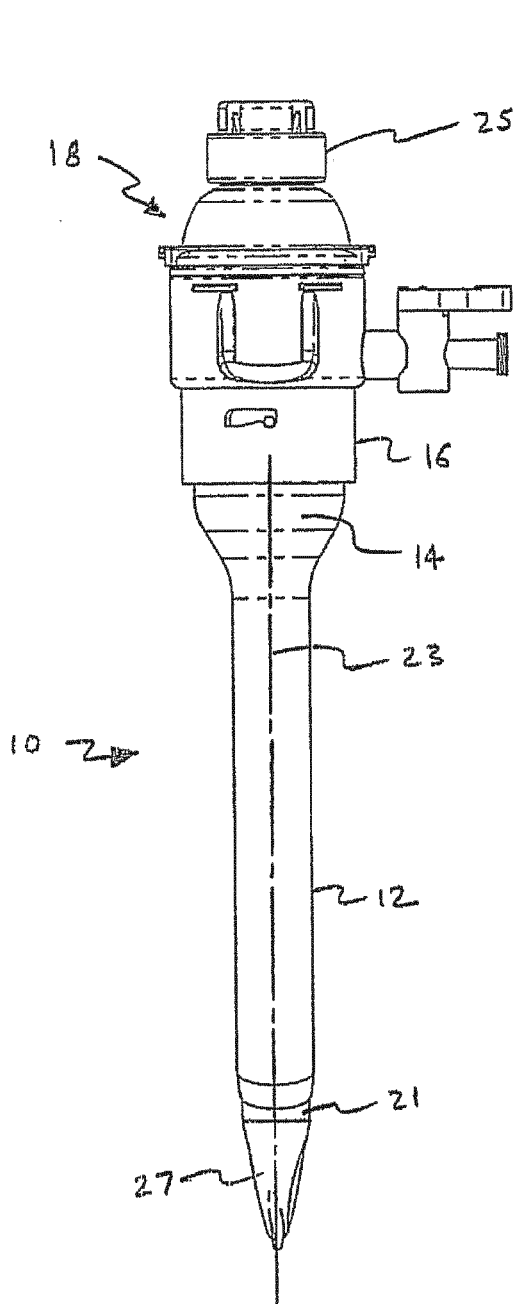

FIG. 1A

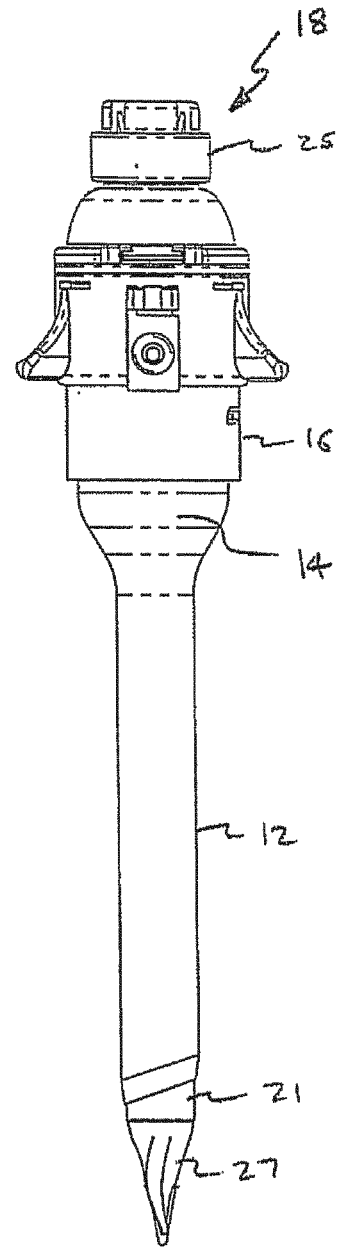

FIG. 1B

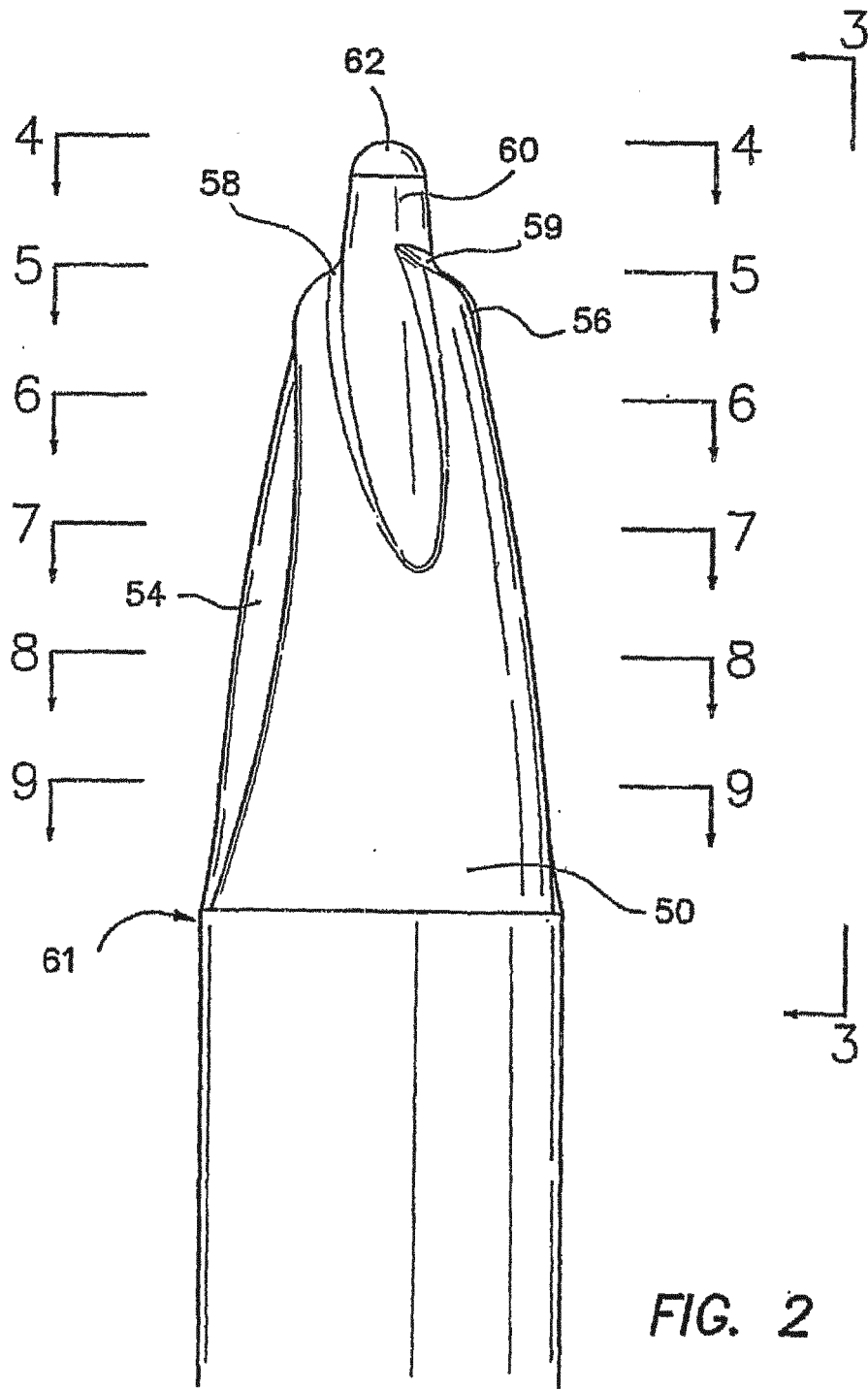
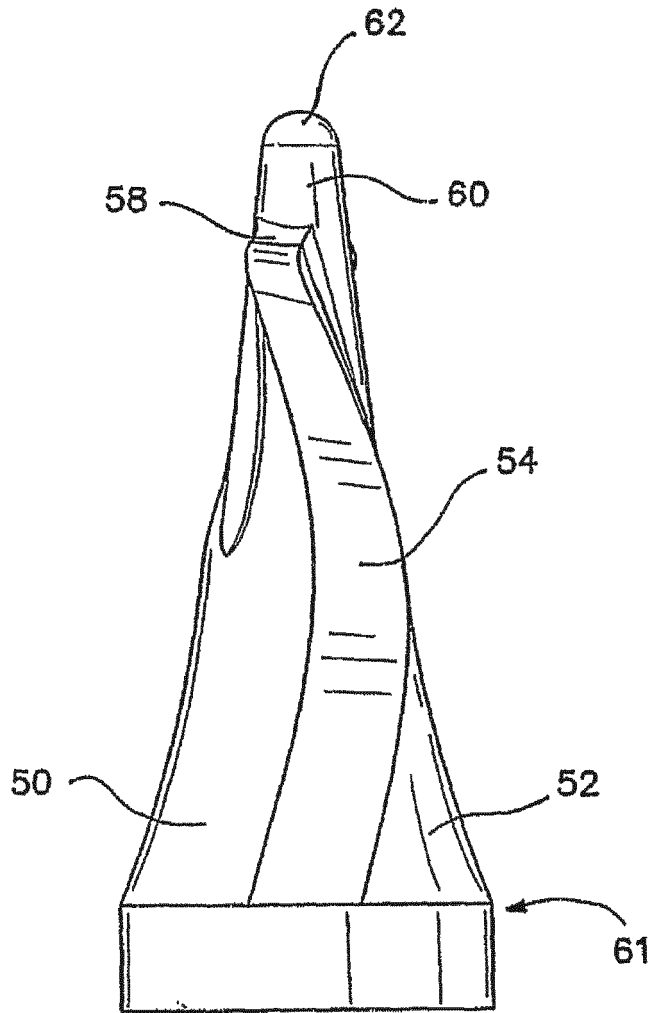
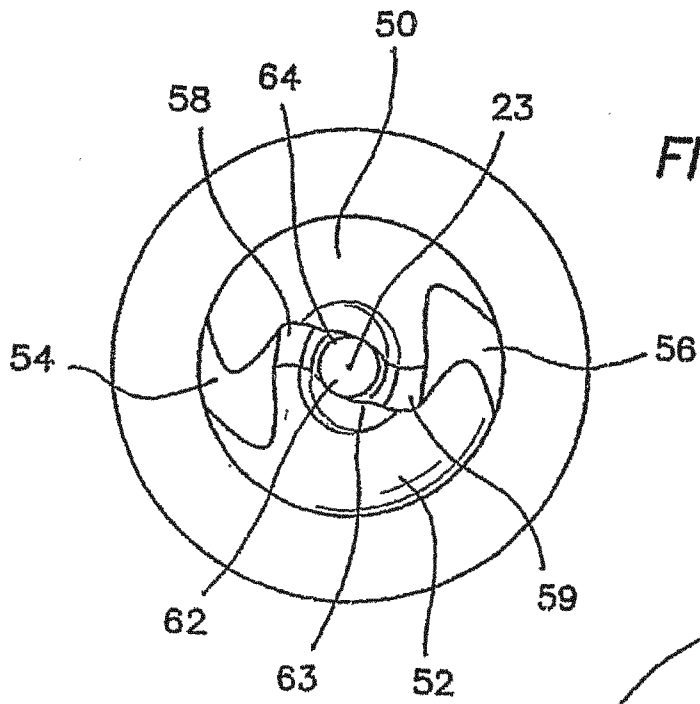

FIG. 2



**FIG. 3**



**FIG. 4**

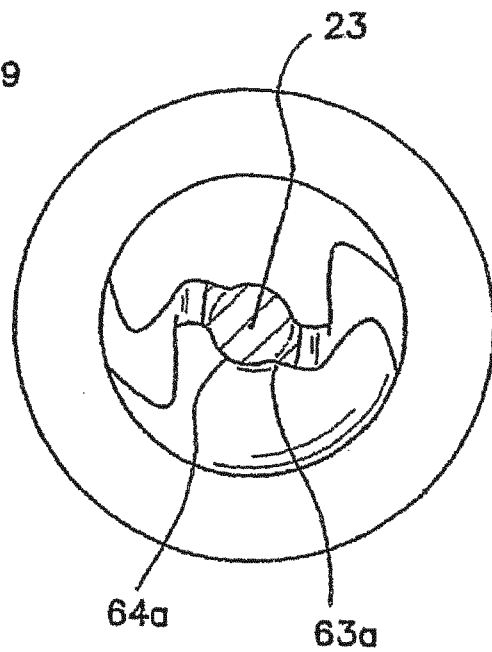

**FIG. 5**

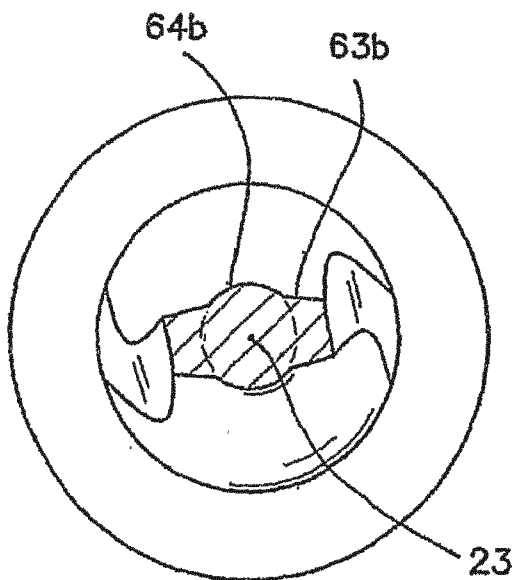

**FIG. 6**

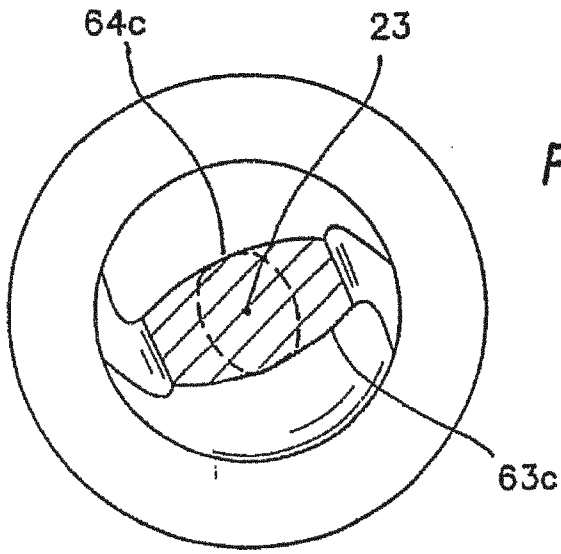

FIG. 7

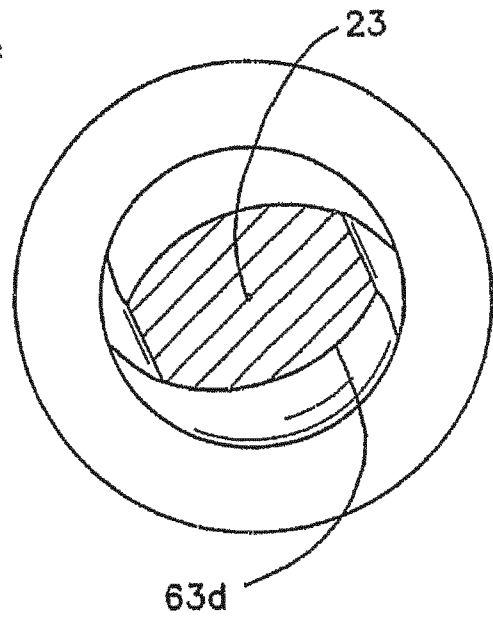

FIG. 8

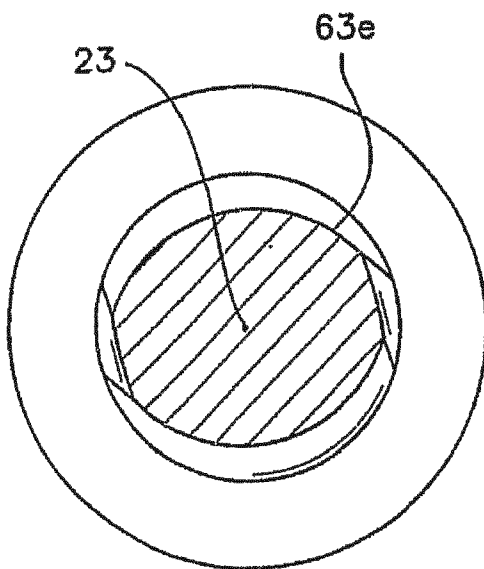

FIG. 9

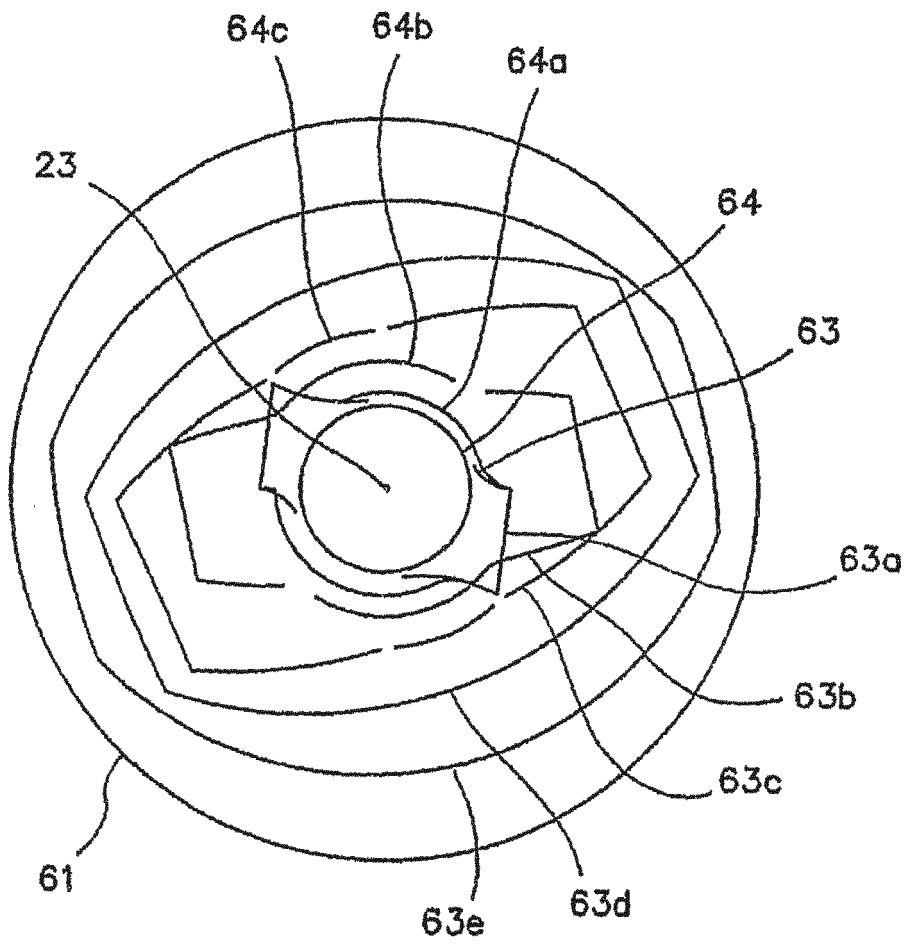

FIG. 10

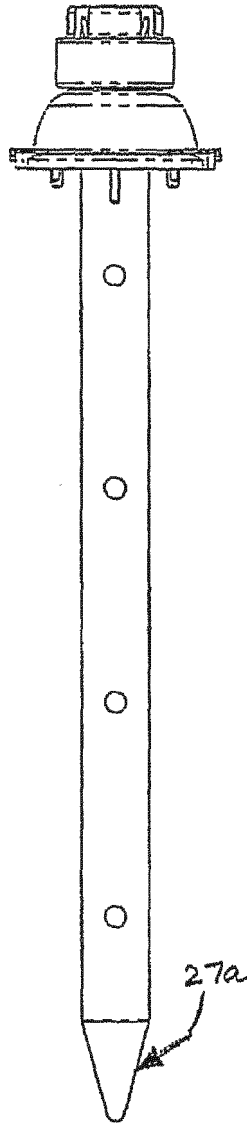

FIG. 11

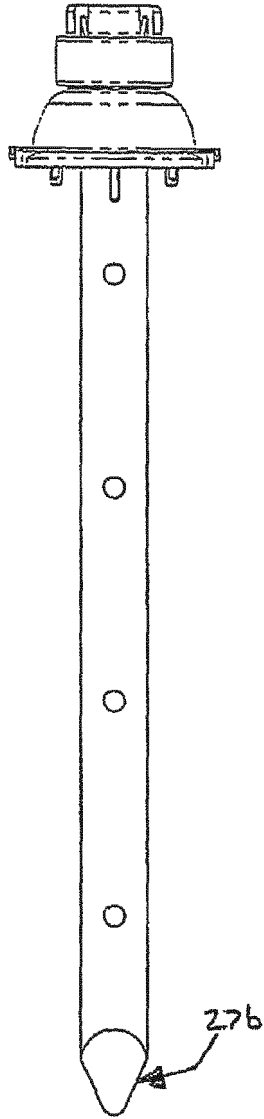

FIG. 12

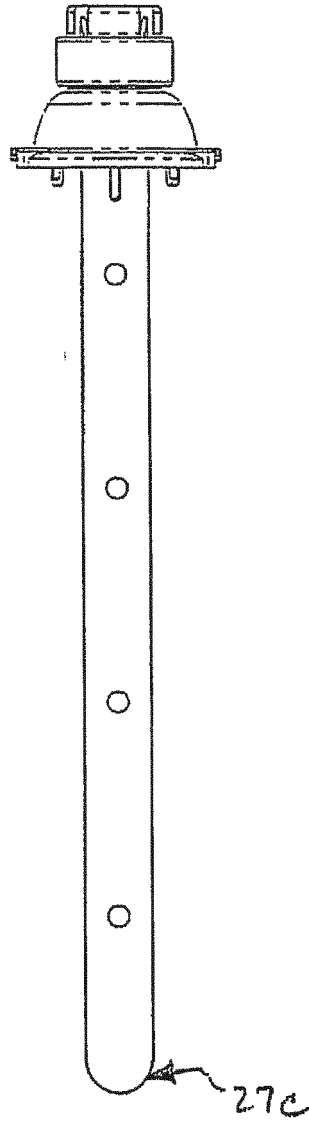

FIG. 13

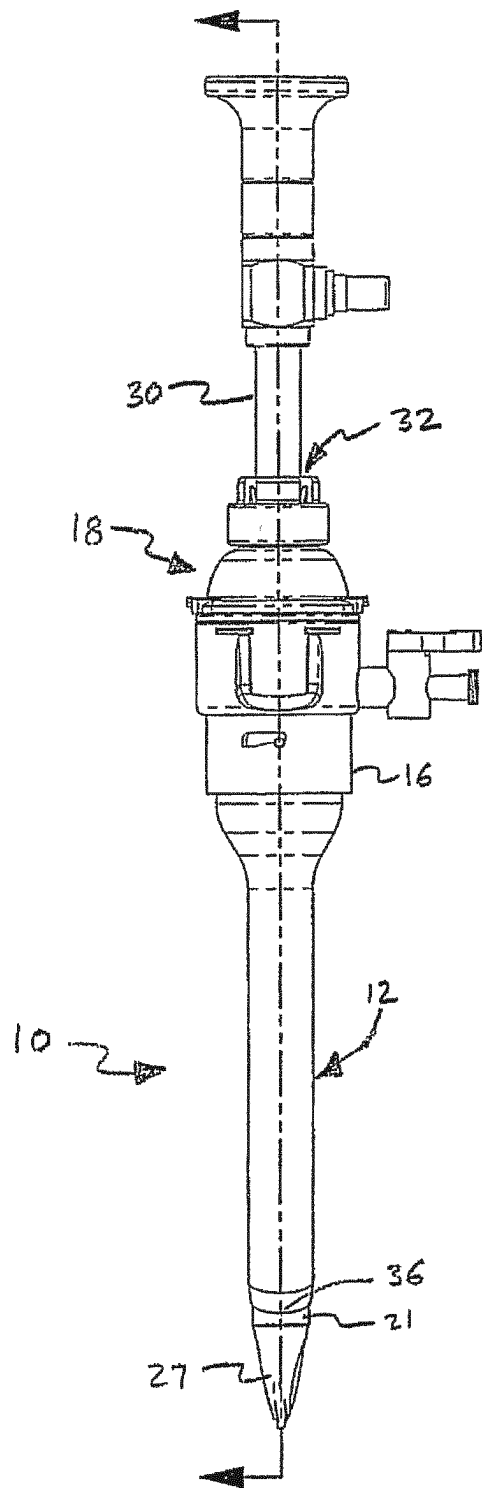

FIG. 14

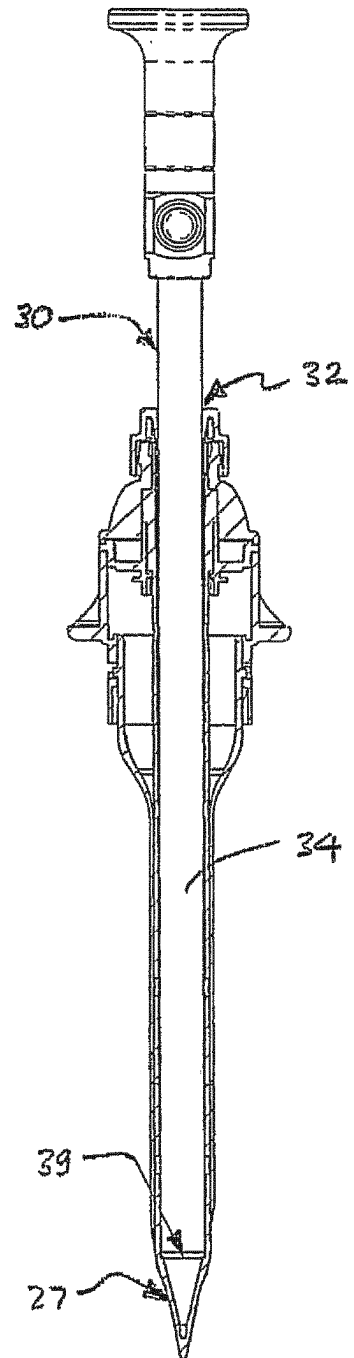

FIG. 15

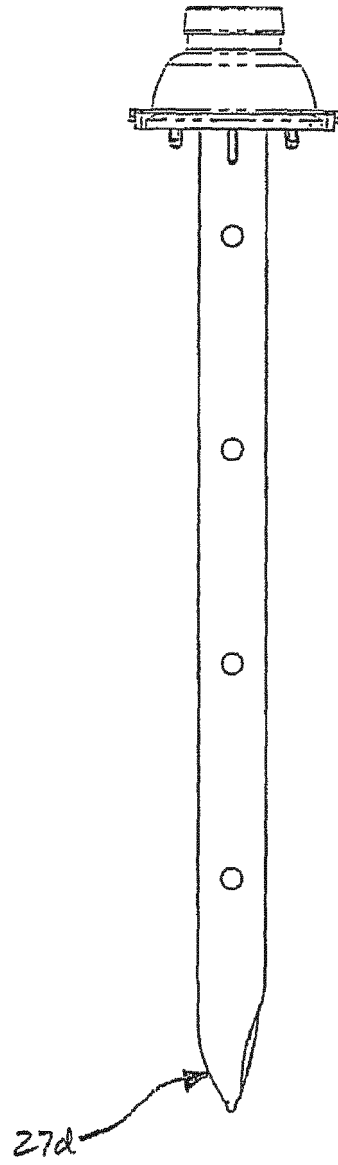

FIG. 16

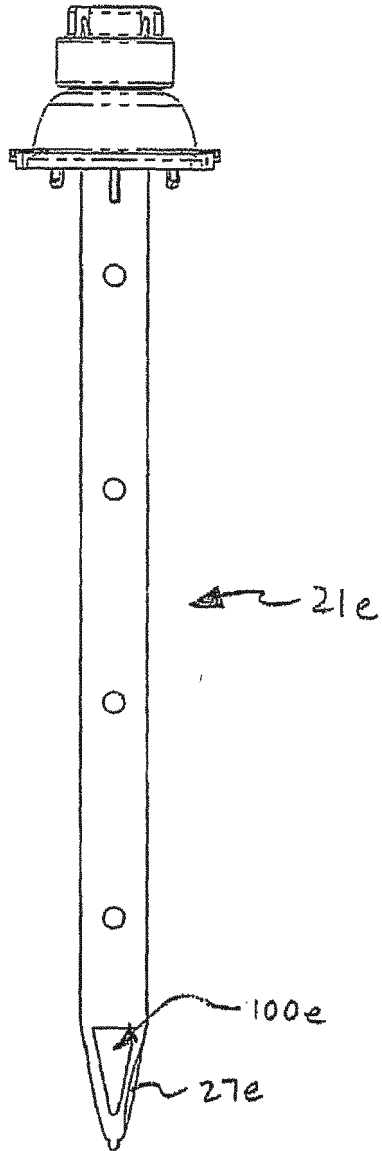

FIG. 17

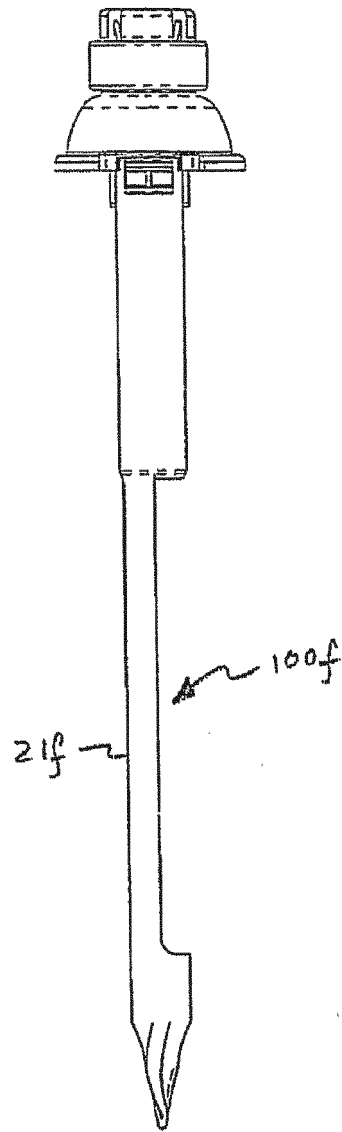

FIG. 18

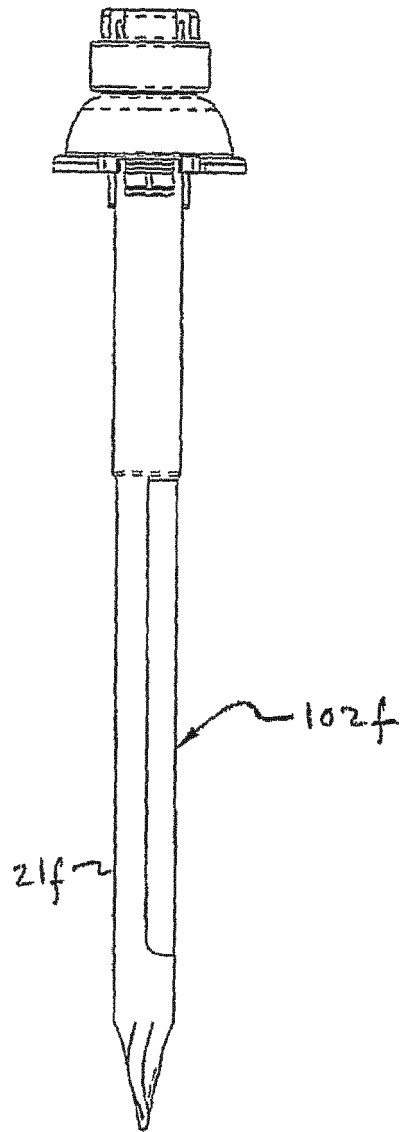

FIG. 19

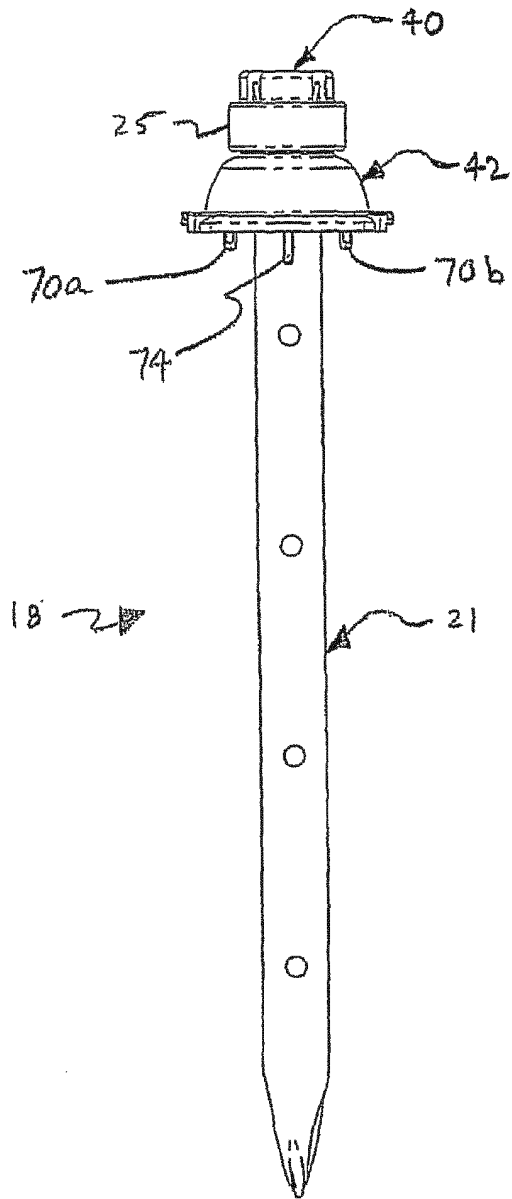

FIG. 20

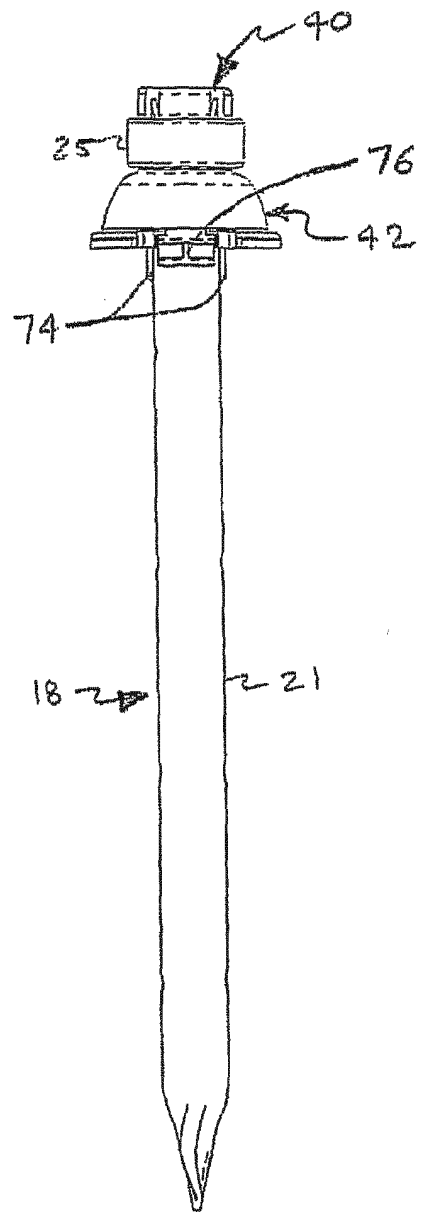

FIG. 21

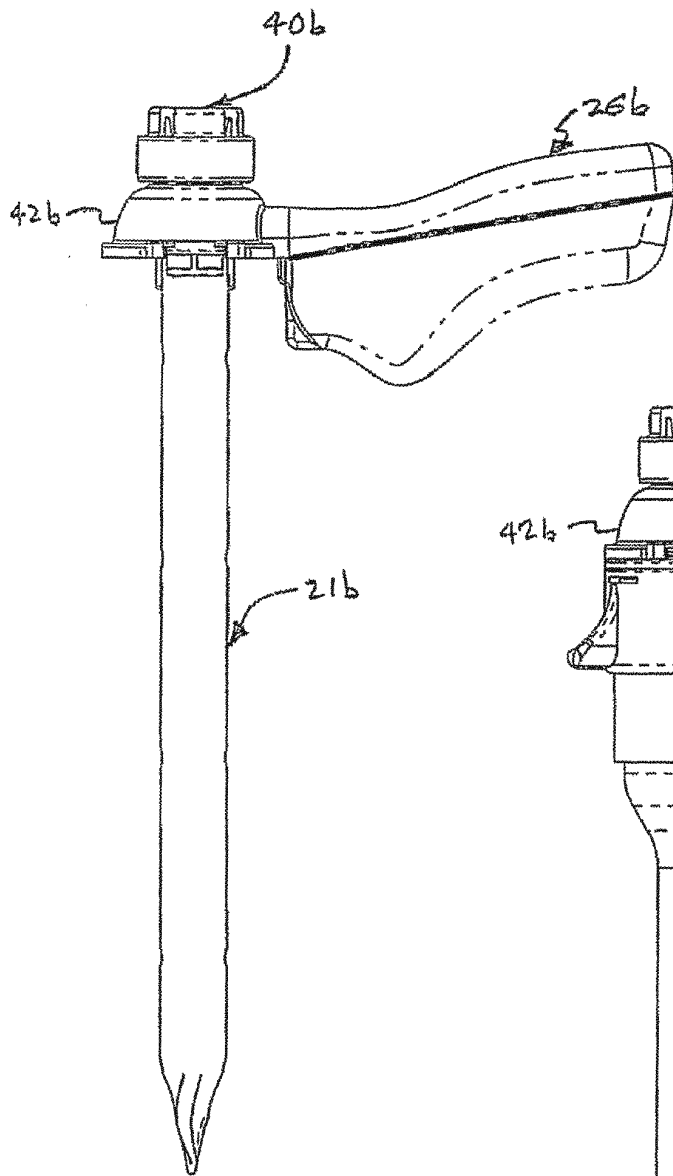

FIG. 22

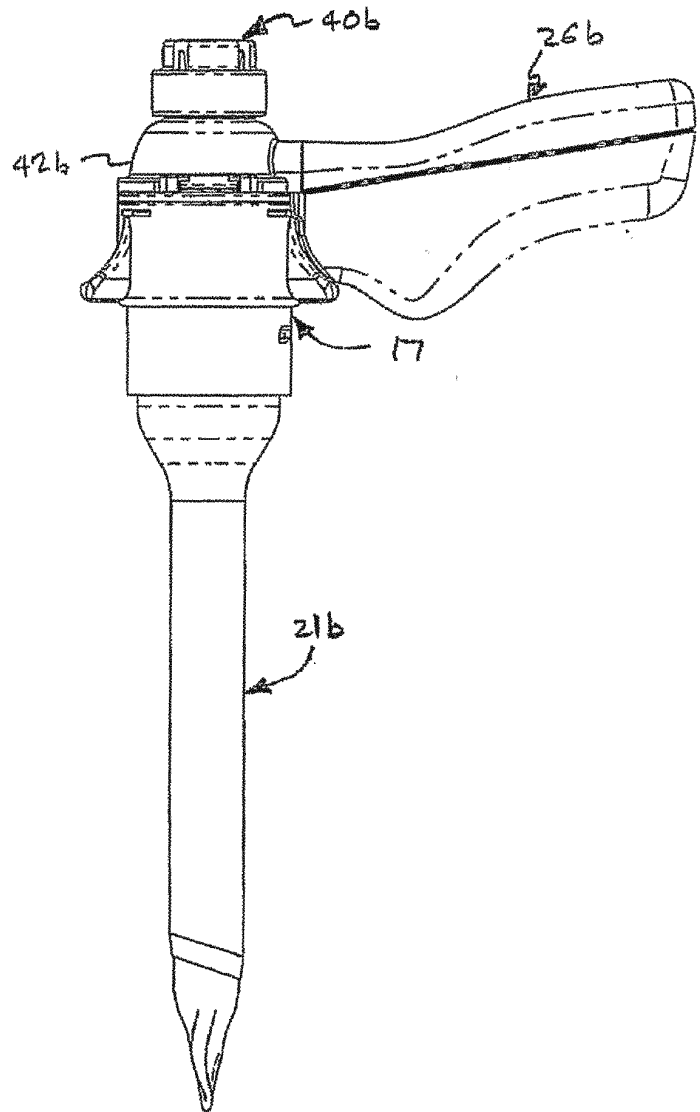

FIG. 23

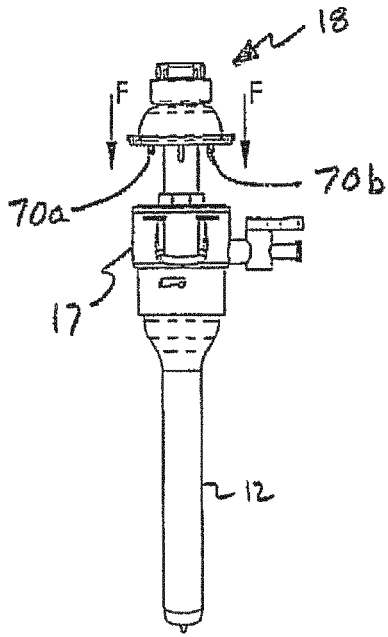

FIG. 24

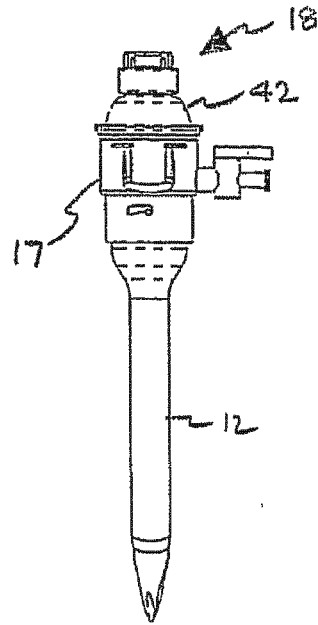

FIG. 25

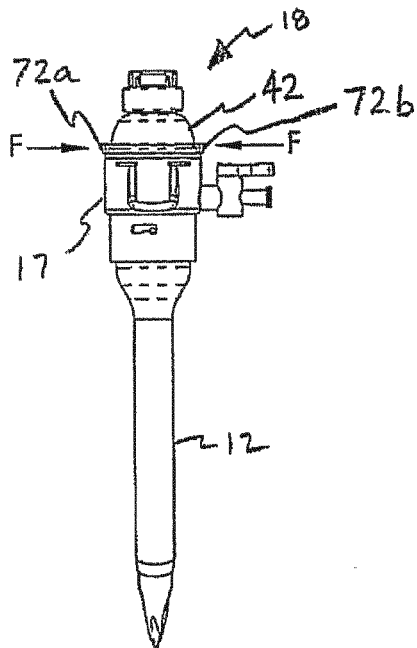

FIG. 26

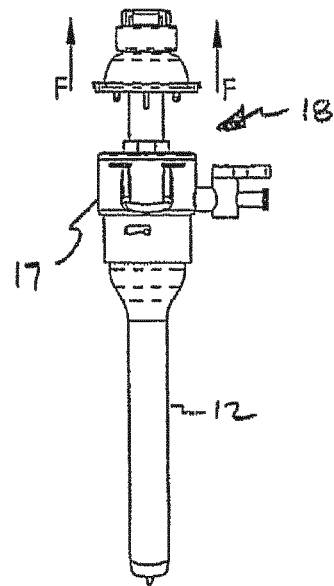

FIG. 27

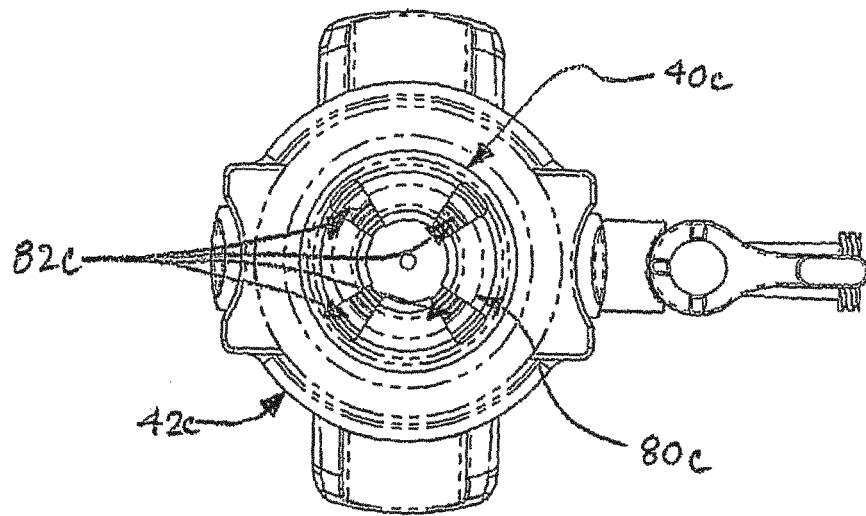

FIG. 28

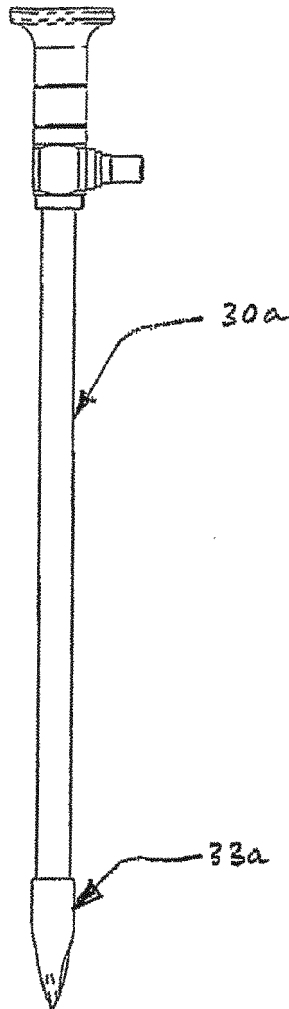

FIG. 29

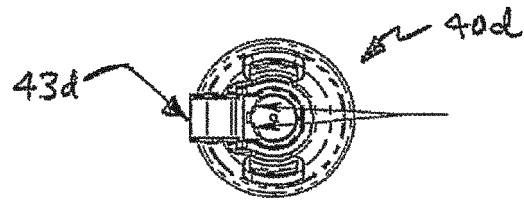

FIG. 30

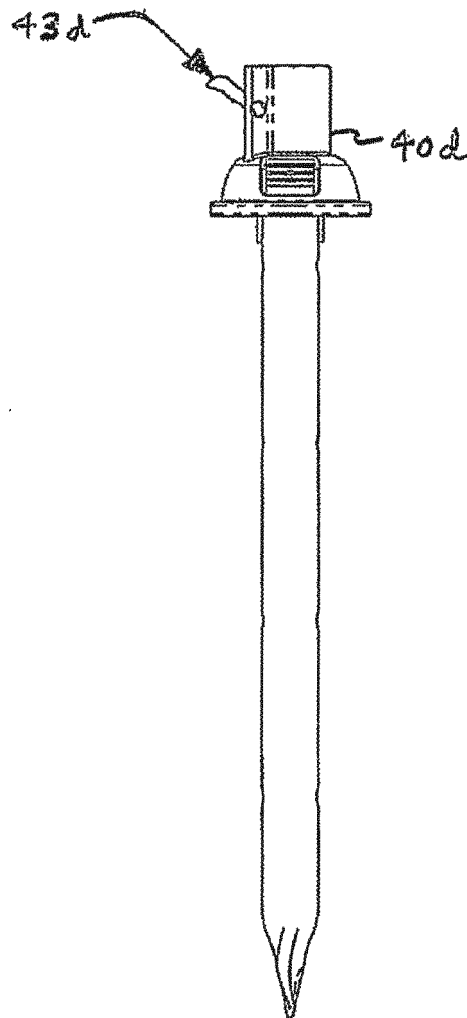

FIG. 31

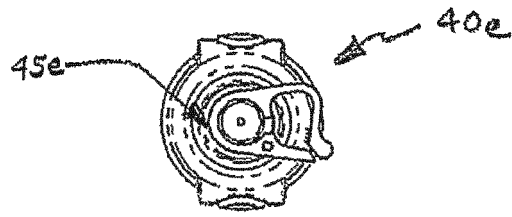

FIG. 32

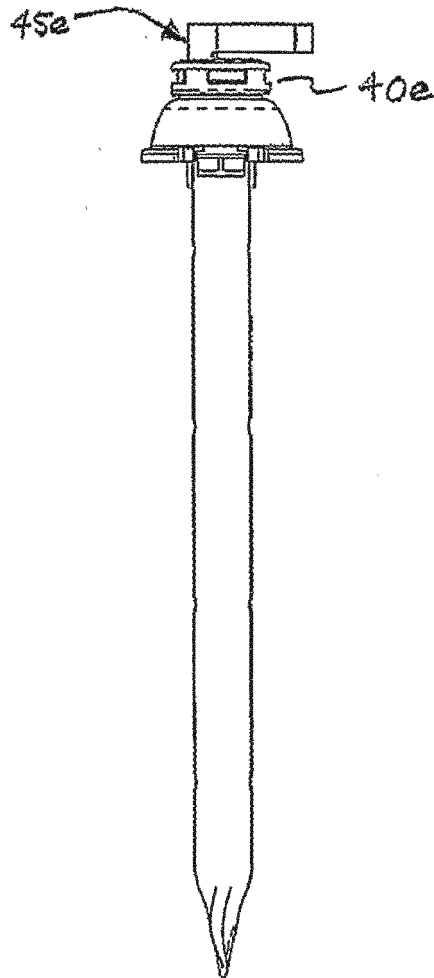

FIG. 33

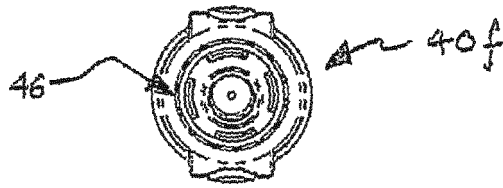

FIG. 34

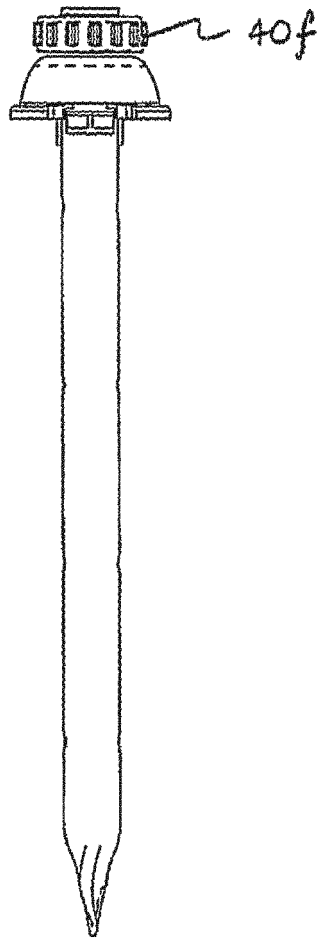

FIG. 35

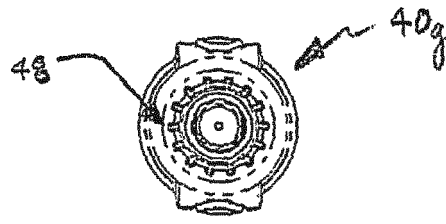

FIG. 36

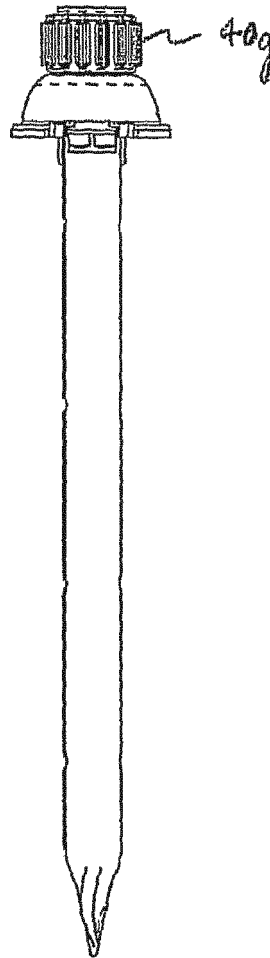

FIG. 37

**REFERENCES CITED IN THE DESCRIPTION**

*This list of references cited by the applicant is for the reader's convenience only. It does not form part of the European patent document. Even though great care has been taken in compiling the references, errors or omissions cannot be excluded and the EPO disclaims all liability in this regard.*

**Patent documents cited in the description**

- WO 03026512 A [0002]
- WO 9601074 A [0002]
- US 5569291 A [0002]

专利名称(译)	无叶光学闭孔器		
公开(公告)号	<a href="#">EP2921121B1</a>	公开(公告)日	2016-09-07
申请号	EP2015163037	申请日	2004-10-01
[标]申请(专利权)人(译)	应用医疗资源		
申请(专利权)人(译)	应用医疗资源CORPORATION		
当前申请(专利权)人(译)	应用医疗资源CORPORATION		
[标]发明人	KAHLE HENRY STROKOSZ ARKADIUSZ A MCGINLEY KIMBALL B TAYLOR SCOTT V JOHNSON GARY M BRUSTAD JOHN R		
发明人	KAHLE, HENRY STROKOSZ, ARKADIUSZ A. MCGINLEY, KIMBALL B. TAYLOR, SCOTT V. JOHNSON, GARY M. BRUSTAD, JOHN R.		
IPC分类号	A61B17/32 A61B17/34 A61B90/92 A61B A61B17/00 A61B19/00		
CPC分类号	A61B17/3417 A61B17/3462 A61B17/3474 A61B17/3478 A61B17/3496 A61B90/361 A61B90/92 A61B2017/0046 A61B2017/00477 A61B2017/00907 A61B2017/320044 A61B2017/3456 A61B2017 /346 A61B2017/3464 A61B2017/347 A61B2090/3937 A61B1/3132 A61B17/3415 A61B17/3421 A61B17 /3423 A61B17/3468 A61B2017/3425 A61B2017/3445		
优先权	60/508390 2003-10-03 US		
其他公开文献	EP2921121A1		
外部链接	<a href="#">Espacenet</a>		

摘要(译)

本发明涉及一种无刀片套管针闭塞器，用于在穿过体壁插入期间分离或分叉身体组织。在一个方面，本发明的填塞器包括沿近端和远端之间的轴线延伸的轴；无刀片尖端设置在轴的远端并且具有带有外表面的大致锥形构造，外表面向远侧延伸到钝点，其中一对侧部具有共同的形状并且被至少一个中间件分开该部分，其中每个侧面部分从钝点径向向外延伸，沿着轴向近侧具有渐进位置，并且轴的尺寸和构造适于接收具有远端的光学仪器以接收身体组织的图像。在这方面，锥形构造有利于身体组织的不同层的分离，并提供层之间的尖端的适当对准。侧部包括远端部分和近端部分，侧部的远端部分相对于侧部的近端部分径向扭转。中间区段包括远侧部分和近侧部分，中间区段的远侧部分沿第一径向方向扭转，并且中间区段的近侧部分沿与第一径向方向相反的第二径向方向扭转。

