

(19)



(11)

**EP 2 521 505 B1**

(12)

**EUROPEAN PATENT SPECIFICATION**

(45) Date of publication and mention of the grant of the patent:  
**06.09.2017 Bulletin 2017/36**

(51) Int Cl.:  
**A61B 18/20** <sup>(2006.01)</sup> **A61B 18/22** <sup>(2006.01)</sup>  
**A61F 9/008** <sup>(2006.01)</sup>

(21) Application number: **10798941.0**

(86) International application number:  
**PCT/US2010/062467**

(22) Date of filing: **30.12.2010**

(87) International publication number:  
**WO 2011/084863 (14.07.2011 Gazette 2011/28)**

(54) **FIBER LASERS AND MID-INFRARED LIGHT SOURCES IN METHODS AND SYSTEMS FOR SELECTIVE BIOLOGICAL TISSUE PROCESSING AND SPECTROSCOPY**

FASERLASER UND MITTELINFRAROTLICHTQUELLEN IN VERFAHREN UND SYSTEMEN FÜR SELEKTIVE VERARBEITUNG VON BIOLOGISCHEM GEWEBE UND SPEKTROSKOPIE

LASERS À FIBRE, ET SOURCES DE LUMIÈRE DANS L'INFRAROUGE MOYEN, DANS DES PROCÉDÉS ET SYSTÈMES POUR LE TRAITEMENT ET LA SPECTROSCOPIE SÉLECTIVE DE TISSUS BIOLOGIQUES

(84) Designated Contracting States:  
**AL AT BE BG CH CY CZ DE DK EE ES FI FR GB GR HR HU IE IS IT LI LT LU LV MC MK MT NL NO PL PT RO RS SE SI SK SM TR**

(72) Inventor: **ISLAM, Mohammed N.**  
**Ann Arbor**  
**Michigan 48105 (US)**

(30) Priority: **07.01.2010 US 335440 P**  
**07.01.2010 US 335455 P**  
**07.01.2010 US 335456 P**

(74) Representative: **Parker, Andrew James et al**  
**Meissner Bolte Patentanwälte**  
**Rechtsanwälte Partnerschaft mbB**  
**Widenmayerstraße 47**  
**80538 München (DE)**

(43) Date of publication of application:  
**14.11.2012 Bulletin 2012/46**

(56) References cited:  
**US-A1- 2004 034 341 US-A1- 2008 015 557**  
**US-A1- 2008 058 783 US-A1- 2008 132 886**  
**US-A1- 2008 269 735 US-A1- 2009 028 193**  
**US-A1- 2009 263 485 US-A1- 2009 326 617**  
**US-B1- 6 251 103 US-B1- 7 633 673**

(73) Proprietor: **Omni MedSci, Inc.**  
**Ann Arbor, MI 48103 (US)**

**EP 2 521 505 B1**

Note: Within nine months of the publication of the mention of the grant of the European patent in the European Patent Bulletin, any person may give notice to the European Patent Office of opposition to that patent, in accordance with the Implementing Regulations. Notice of opposition shall not be deemed to have been filed until the opposition fee has been paid. (Art. 99(1) European Patent Convention).

## Description

### Technical Field Of The Invention

**[0001]** This invention relates in general to lasers and light sources for healthcare, medical, or bio-technology applications, and more particularly to systems and methods for therapeutically, selectively damaging or processing biological material associated with certain tissue types, or using spectroscopy to selectively diagnose the presence of certain tissue types.

**[0002]** US2009028193 discloses a broadband light source which includes one or more laser diodes that are capable of generating a pump signal having a wavelength shorter than 2.5 microns, a pulse width of at least 100 picoseconds and a pump optical spectral width. US20080015557 discloses a fractional treatment system with an adjustable mechanism which can be used to adjust the beam shape, beam numerical aperture, beam focus depth and/or beam size to affect the treatment depths and or the character of the resulting lesions.

### Overview

**[0003]** Many of the lasers that are used in healthcare, medical or bio-technology applications operated on the basis of absorption of the light in water. However, since water pervades most biological tissue, the medical lasers tend not to be selective to a particular tissue type. During medical procedures using such non-selective lasers, there can be additional risk and complications from unwanted collateral damage. Also, for laser wavelengths that are significantly absorbed by water, the light may not penetrate very far into the tissue. Consequently, lasers tend to treat only the surface of the tissue exposed to the light. Therefore, there exists a need for lasers and procedures based on light sources or lasers that can be selective and that can penetrate deeper into tissue.

**[0004]** Mid-infrared lasers, such as lasers that operate between approximately 1 and 10 microns, preferably between 1.2 and 4.5 microns, can be implemented that operate near absorption peaks of various tissues, such as adipose (e.g., fat, cholesterol, lipids), collagen and elastin. Moreover, the wavelength of the lasers can be selected to minimize water absorption and scattering through tissue. Thus, mid-infrared lasers tuned to optical absorption in particular tissue constituents can be used in one embodiment for selective damage in therapeutic procedures. In another embodiment, the optical absorption or reflection spectroscopy can be used as a diagnostic technique to differentiate between different tissue types. Moreover, by operating at mid-infrared wavelengths with less water absorption and tissue scattering, the penetration depth for the light can be increased to several millimeters, as an example. These features of mid-infrared light can be beneficial in a number of medical fields, including but not limited to ophthalmology, dermatology, cardiology and neurology as well as treatment of

type 2 diabetes and other ailments associated with obesity.

**[0005]** The following U.S. patent references are related to at least one example, embodiment of the present invention: 5,618,284; 5,779,696, 6,159,205; 6,605,080; 6,986,764; 7,060,061; 7,633,673; and 2009/0054879.

**[0006]** In a system embodiment, a system for selectively processing biological target material characterized by an absorptive coefficient in a therapeutic procedure is provided. The system includes a laser subsystem for generating an output laser beam along a propagation path which extends through an opening in a body and into an interior body cavity. The beam has optical and temporal properties and a predetermined wavelength based on the absorptive coefficient of the target material. The system also includes a beam delivery and focusing subsystem disposed in the propagation path and that accepts the output laser beam and relatively positions the beam into a plurality of focused spots on the target material for a duration sufficient to allow laser energy to be absorbed by the target material and converted to heat to produce a desired physical change in the target

**[0007]** US 2008/132886 a system according to the preamble of claim 1. Further relevant documents are held to be US 2008/059793 and US 2008/269735.

### Summary of the Invention

**[0008]** The present invention relates to a system for selectively processing biological target material according to independent claim 1. The dependent claims therefrom highlight additional preferred embodiments.

**[0009]** The claimed invention can be better understood in view of the embodiments of the system described hereinafter. In general, the described concepts describe related examples and preferred embodiments of the invention. The attentive reader will note, however, that some aspects of the described embodiments extend beyond the scope of the claims. To the respect that the described embodiments indeed extend beyond the scope of the claims, the described embodiments are to be considered supplementary background information and do not constitute definitions of the invention per se. This also holds for the subsequent "Brief Description of the Drawings" as well as the "Detailed Description of Example Embodiments."

### Brief Description Of The Drawings

**[0010]** For a more complete understanding of the present invention, and for further features and advantages thereof, reference is now made to the following description taken in conjunction with the accompanying drawings, in which:

FIGURE 1 illustrates the optical absorbance spectrum for four types of collagen in the mid-infrared wavelength range between 1200nm (1.2 microns)

and 2400nm (2.4 microns); the upper left curve corresponds to the absorbance for collagen I, the upper right curve corresponds to the absorbance for collagen II, the lower left curve corresponds to the absorbance for collagen III, and the lower right curve corresponds to the absorbance for collagen IV;

FIGURE 2 illustrates the optical absorbance of elastin in the mid-infrared wavelength range between approximately 1200nm, and 2400nm;

FIGURE 3 overlaps the absorption coefficients of adipose tissue with collagen I and elastin; vertical lines are also drawn to highlight the wavelengths near 1210nm and 1720nm; the adipose absorption coefficient is shown on a calibrated scale, while the collagen and elastin are in arbitrary units;

FIGURE 4 illustrates separately the exemplary water absorption and scattering loss; the top of FIGURE 4 is the reduced scattering coefficient through tissue such as dermis, while the bottom of FIGURE 4 is the absorption coefficient of water;

FIGURE 5 illustrates exemplary the combined water absorption and scattering loss curves; FIGURE 5 adds the two curves of FIGURE 4 to provide the resulting water absorption and scattering loss;

FIGURE 6 illustrates the overlap of the absorption coefficients for water, adipose, collagen and elastin; vertical lines are also drawn to highlight the wavelengths near 1210nm and 1720nm; the adipose and water absorption coefficients are shown on a calibrated scale, while the collagen and elastin are in arbitrary units;

FIGURE 7 illustrates the overlap of the absorption coefficients for water and tissue scattering, adipose, collagen and elastin; vertical lines are also drawn to highlight the wavelengths near 1210nm and 1720nm; the adipose and water absorption coefficients as well as the scattering loss are shown on a calibrated scale, while the collagen and elastin are in arbitrary units;

FIGURE 8 illustrates a block diagram of one embodiment of a mid-infrared fiber laser operating near 1720nm;

FIGURE 9 shows details of one specific example of a mid-infrared fiber laser operating at approximately 1708nm; the top part of the figure illustrates one embodiment of the pump fiber laser, and the bottom part of the figure illustrates one embodiment of the cascaded Raman oscillator or cascaded Raman wavelength shifter;

FIGURE 10A illustrates a block diagram yet another embodiment of a mid-infrared fiber laser operating near 1210nm;

FIGURE 10B shows details of one specific example of a mid-infrared fiber laser operating at approximately 1212nm; the top part of the figure illustrates one embodiment of the pump fiber laser, and the bottom part of the figure illustrates one embodiment of the cascaded Raman oscillator or cascaded Raman wavelength shifter;

FIGURE 11A illustrates a block diagram of one embodiment of a mid-infrared super-continuum fiber laser;

FIGURE 11B shows a particular example of a mid-infrared super-continuum laser that can generate relatively high powers;

FIGURE 12A illustrates details of different exemplary super-continuum lasers; the top of the figure provides details of an SC source that can provide light from approximately 1400nm to 1800nm or broader, while the bottom of the figure provides details of an SC source that can provide light from about 1900nm to 2500nm or broader;

FIGURE 12B illustrates one embodiment of a thulium-doped fiber laser operating near a center wavelength around 1720 to 1750nm or longer; the top left curve shows exemplary absorption bands for thulium in fused silica fiber, and the top right curve shows exemplary absorption and emission bands for thulium in the wavelength range between approximately 1400 and 2100nm; the bottom configuration illustrates one embodiment of the thulium-doped fiber laser operating in the mid-infrared wavelength range;

FIGURE 13 illustrates experimental results for the depth of damage obtained in an in-vitro human skin sample plotted as a function of laser fluence at about 1708nm incident on the skin sample;

FIGURE 14 illustrates a cross-sectional view of the human eye; the right side of the diagram is an enlarged view of the various layers comprising the cornea;

FIGURE 15 is a schematic of some of the main layers of the human skin; for example, the dermis comprises collagen and elastin;

FIGURE 16 shows an exemplary sketch of human skin and the definitions of a skin line, skin wrinkle and skin fold;

FIGURE 17 provides a schematic of a normal artery (left) and an artery with atherosclerotic plaque build-up on the inside walls (right);

FIGURE 18 illustrates exemplary measured optical spectra of constituents in atherosclerotic plaque and normal artery walls between the wavelengths of approximately 2600nm and 3800nm; some of the constituents of normal artery include: (a) endothelium cell and (b) smooth muscle cell; some of the constituents of atherosclerotic plaque include: (c) macrophage, (d) fat tissue, and (e) foam cells;

FIGURE 19 illustrates the optical absorption of egg yolk and endothelial cells; for example, by using light in the wavelength range near 3300 to 3600nm, the egg yolk can be selectively damaged compared with endothelial cells;

FIGURE 20 illustrates an exemplary laparoscopic device for use for introducing light into the abdominal region; in one embodiment, such a laparoscopic device could be used to remove visceral adipose tissue;

FIGURE 21 shows a schematic for an exemplary probe or catheter that can be used for inspection into an artery;

FIGURE 22 illustrates the transmission (one minus the absorbance) through fatty tissue, aorta and heart muscle or myocardium without endo- or epi-cardium; the longer arrows indicate some of the water absorption bands, while the shorter arrows indicate some of the approximate absorption bands in fatty tissue; and

FIGURE 23 illustrates near-infrared spectroscopy data for diagnosing colorectal or pancreatic cancer; the top left hand side shows near-infrared spectra for normal and cancerous pancreas and colorectal tissue, while the bottom left hand side enhances the changes by differentiating the reflectance to show the missing lipid lines ; the right hand side enlarges the data in the wavelength range between approximately 1670 and 1790nm, which illustrates the contrast between normal and cancerous colorectal tissue.

#### Detailed Description Of Example Embodiments

**[0011]** Mid-infrared light sources can be used for diagnostics and therapeutics in a number of medical applications. For example, broadband light sources can advantageously be used for diagnostics, while narrower band light sources can advantageously be used for therapeutics. In one embodiment, selective absorption or damage can be achieved by choosing the laser wavelength to lie approximately at an absorption peak of particular tissue

types. Also, by using mid-infrared wavelengths that minimize water absorption peaks and longer wavelengths that have lower tissue scattering, larger penetration depths into the biological tissue can be obtained. As an example, tissues such as adipose, collagen and elastin have absorption peaks in the mid-infrared wavelengths. In this disclosure, we define mid-infrared wavelengths as wavelengths in the range of 1 to 10 microns, more preferably wavelengths between about 1.2 and 4.5 microns.

**[0012]** As used throughout this document, the term "couple" and or "coupled" refers to any direct or indirect communication between two or more elements, whether or not those elements are physically connected to one another. In this disclosure, the term "damage" refers to affecting a tissue or sample so as to render the tissue or sample inoperable. For instance, if a particular tissue normally emits certain signaling chemicals, then by "damaging" the tissue is meant that the tissue reduces or no longer emits that certain signaling chemical. The term "damage" and or "damaged" may include ablation, melting, charring, killing, or simply incapacitating the chemical emissions from the particular tissue or sample. In one embodiment, histology or histochemical analysis may be used to inspect if a tissue or sample has been damaged.

**[0013]** As used throughout this disclosure, the term "spectroscopy" means that a tissue or sample is inspected by comparing different features, such as wavelength (or frequency), spatial location, transmission, absorption, reflectivity, scattering, refractive index, or opacity. In one embodiment, "spectroscopy" may mean that the wavelength of the light source is varied, and the transmission, absorption or reflectivity of the tissue or sample is measured as a function of wavelength. In another embodiment, "spectroscopy" may mean that the wavelength dependence of the transmission, absorption or reflectivity is compared between different spatial locations on a tissue or sample. As an illustration, the "spectroscopy" may be performed by varying the wavelength of the light source, or by using a broadband light source and analyzing the signal using a spectrometer, wavemeter, or optical spectrum analyzer.

**[0014]** As used throughout this document, the term "fiber laser" refers to a laser or oscillator that has as an output light or an optical beam, wherein at least a part of the laser comprises an optical fiber. For instance, the fiber in the "fiber laser" may comprise one of or a combination of a single mode fiber, a multi-mode fiber, a mid-infrared fiber, a photonic crystal fiber, a doped fiber, a gain fiber, or, more generally, an approximately cylindrically shaped waveguide or light-pipe. In one embodiment, the gain fiber may be doped with rare earth material, such as ytterbium, erbium, thulium. In another embodiment, the mid-infrared fiber may comprise one or a combination of fluoride fiber, ZBLAN fiber, chalcogenide fiber, tellurite fiber, or germanium doped fiber. In yet another embodiment, the single mode fiber may include standard single-mode fiber, dispersion shifted fiber, non-zero dispersion shifted fiber, high-nonlinearity fiber, and

small core size fibers.

**[0015]** As used throughout this disclosure, the term "pump laser" refers to a laser or oscillator that has as an output light or an optical beam, wherein the output light or optical beam is coupled to a gain medium to excite the gain medium, which in turn may amplify another input optical signal or beam. In one particular example, the gain medium may be a doped fiber, such as a fiber doped with ytterbium, erbium or thulium. In one embodiment, the "pump laser" may be a fiber laser, a solid state laser, a laser involving a nonlinear crystal, an optical parametric oscillator, a semiconductor laser, or a plurality of semiconductor lasers that may be multiplexed together. In another embodiment, the "pump laser" may be coupled to the gain medium by using a fiber coupler, a dichroic mirror, a multiplexer, a wavelength division multiplexer, a grating, or a fused fiber coupler.

**[0016]** As used throughout this document, the term "super-continuum" and or "supercontinuum" and or "SC" refers to a broadband light beam or output that comprises a plurality of wavelengths. In a particular example, the plurality of wavelengths may be adjacent to one-another, so that the spectrum of the light beam or output appears as a continuous band when measured with a spectrometer. In one embodiment, the broadband light beam may have a bandwidth or at least 10nm. In another embodiment, the "super-continuum" may be generated through nonlinear optical interactions in a medium, such as an optical fiber or nonlinear crystal. For example, the "super-continuum" may be generated through one or a combination of nonlinear activities such as four-wave mixing, the Raman effect, modulational instability, and self-phase modulation.

**[0017]** As used throughout this disclosure, the terms "optical light" and or "optical beam" and or "light beam" refer to photons or light transmitted to a particular location in space. The "optical light" and or "optical beam" and or "light beam" may be modulated or unmodulated, which also means that they may or may not contain information. In one embodiment, the "optical light" and or "optical beam" and or "light beam" may originate from a fiber, a fiber laser, a laser, a light emitting diode, a lamp, a pump laser, or a light source.

**[0018]** As used throughout this document, the term "near 1720nm" refers to one or more wavelengths of light with a wavelength value anywhere between approximately 1680nm and 1760nm. In a preferred embodiment, the term "near 1720nm" refers to one or more wavelengths of light with a wavelength value anywhere between approximately 1700nm and 1740nm. Similarly, as used throughout this document, the term "near 1210nm" refers to one or wavelengths of light with a wavelength value anywhere between approximately 1170nm and 1250nm. In a preferred embodiment, the term "near 1210nm" refers to one or wavelengths of light with a wavelength value anywhere between approximately 1190nm and 1230nm.

**[0019]** To better understand the diagnostic and thera-

peutic applications, the optical spectra of a number of tissue types or tissue constituents are first reviewed.

#### *Optical Spectra For Different Tissue Constituents*

**[0020]** FIGURE 1 illustrates the optical absorbance for different types of collagen 100 in the mid-infrared wavelength range between approximately 1200 and 2400nm, which also corresponds to 1.2 to 2.4 microns. The upper left curve 101 is exemplary the absorption spectrum for collagen I, which can be one of the main constituents in the dermis of the skin as well as the cornea of the eye. Curve 102 corresponds to the absorbance for collagen II, curve 103 corresponds to the absorbance for collagen III, and curve 104 to the absorbance for collagen IV. In cardiology, the aorta comprises mostly type I and type III collagen. To be specific when discussing collagen spectra in this disclosure, the spectra for collagen 1101 will be used, unless stated otherwise. In the particular case of collagen I, there are local absorbance peaks near 1210nm and 1720nm. As further discussed below, these wavelength windows can be particularly interesting because of lower water absorption at these wavelengths.

**[0021]** FIGURE 2 illustrates the optical absorbance of elastin 201 in the mid-infrared wavelength range between approximately 1200nm and 2400nm. Elastin can be one of the main constituents of the dermis, and it gives the skin some of the elasticity and springy properties. Elastin can have a unique optical spectrum 200 that differentiates it from collagens 100. Despite the difference in absorbance shape from collagen I, there is also a local absorbance peak near 1720nm.

**[0022]** FIGURE 3 better illustrates similarities and differences in the mid-infrared spectra for collagen 1302 and elastin 303. The two absorbance curves are in arbitrary units, so the shapes and peaks in absorption can be compared, but the amplitudes of the absorption coefficient are arbitrary. Also shown are vertical lines demarking the wavelengths of approximately 1210nm 304 and 1720nm 305. Near 1720nm, both the elastin and collagen have local absorption peaks that nearly coincide in wavelength. Whereas collagen has another local absorption peak near 1210nm, the elastin local peak is about 25nm shorter at approximately 1185nm.

**[0023]** Another tissue type of interest is adipose, which includes fatty tissue and acids, lipids, and cholesterol. FIGURE 3 overlaps the absorption coefficient of adipose tissue 301 with collagen 302 and elastin 303. It can be noted that adipose, collagen and elastin all show a local absorption peak near 1720nm. Also, adipose and collagen have a local absorption peak near 1210nm, although elastin has the local absorption peak closer to 1185nm.

**[0024]** Blood is prevalent throughout the body, and it may be desirable to avoid absorption in blood to achieve selective absorption in certain tissue types. Most of the absorption in blood can be in the visible and ultraviolet wavelengths, and the absorption in hemoglobin is approximately transparent by approximately 1200nm. Be-

yond this wavelength range in the mid-infrared, the absorption coefficient of blood closely resembles the absorption coefficient of water.

**[0025]** In general, to understand the propagation through and penetration into biological tissue, water absorption 402 and scattering loss 401 should be considered. FIGURE 4 illustrates these two contributions to light attenuation separately, and then FIGURE 5 adds the two curves to provide the resulting total absorption and reduced scattering coefficient 501. The bottom of FIGURE 4 plots the absorption coefficient of water 402 in the mid-infrared wavelength range between 1200 and 1900nm, and local peaks in water absorption are seen exemplary near 1450nm and 1940nm. In addition, the top of FIGURE 4 plots the reduced scattering coefficient 401 as measured propagating through the dermis. In accordance with scattering theory, the scattering loss follows an approximate scaling law of the inverse of the square of the wavelength. Therefore, one advantage of using longer wavelengths can be that the scattering loss is reduced. FIGURE 5, which is the sum of the two curves in FIGURE 4, shows that there are relative minima in the total absorption and scattering 501 near 1210nm (approximately  $6.8 \text{ cm}^{-1}$ ) and 1720nm (approximately  $8.25 \text{ cm}^{-1}$ ).

**[0026]** FIGURE 6 illustrates the overlap of the absorption coefficients for water 601, adipose 602, collagen 603 and elastin 604. Note that the absorption curves for water 601 and adipose 602 are calibrated, whereas the absorption curves for collagen 603 and elastin 604 are in arbitrary units. Also shown are vertical lines demarcating the wavelengths near 1210nm 605 and 1720nm 606. As an example, the absorption coefficient for adipose 602 exceeds the water absorption 601 in the wavelength windows near 1210nm and 1720nm. However, near 1210nm there is a local maximum in water absorption, while near 1720nm the wavelength is in the vicinity of a minimum in water absorption. There are peaks in water absorption near 970nm, 1190nm, 1450nm and 1940nm, and there is also a large water peak near 3000nm. Also, in general, the water absorption increases with increasing wavelength. With the increasing absorption beyond about 2000nm, it may be difficult to achieve deeper penetration into biological tissue in the mid-infrared wavelengths beyond 2000nm.

**[0027]** Although FIGURE 6 can be useful for determining the material in which light of a certain mid-infrared wavelength will be absorbed, to determine the penetration depth of the light of a certain wavelength may also require the addition of scattering loss to the curves. For example, FIGURE 7 modifies the figure by also including the scattering loss curve to the water absorption 701 (i.e., uses FIGURE 5 rather than just the water absorption in the bottom of FIGURE 4). Since the scattering loss can be significantly higher at shorter wavelengths, the comparison of adipose absorption 702 to loss propagating through water and tissue scattering 701 can be altered, particularly for wavelengths below approximately 1400nm. In one embodiment, near the wavelength of

1720nm (vertical line 706 shown in FIGURE 7), the adipose absorption 702 can still be higher than the water plus scattering loss 701. For tissue that contains adipose, collagen and elastin, such as the dermis of the skin, the total absorption can exceed the light energy lost to water absorption and light scattering at 1720nm. On the other hand, at 1210nm the adipose absorption 702 can be considerably lower than the water plus scattering loss 701, particularly since the scattering loss can be dominant at these shorter wavelengths. As in FIGURE 6, in FIGURE 7 the absorption curves for water, scattering and adipose are calibrated, whereas the absorption curves for collagen and elastin are in arbitrary units.

**[0028]** One further consideration in choosing the laser wavelength is known as the "eye safe" window. In particular, wavelengths in the eye safe window may not transmit down to the retina of the eye, and therefore, these wavelengths may be less likely to create permanent eye damage. The mid-infrared wavelengths have the potential to be dangerous, because the eye cannot see the wavelengths (as it can in the visible), yet they can penetrate and cause damage to the eye. Even if a practitioner is not looking directly at the laser beam, the practitioner's eyes may receive stray light from a reflection or scattering some surface. Hence, it can always be a good practice to use eye protection when working around lasers.

**[0029]** Since wavelengths longer than about 1400nm are substantially not transmitted to the retina or substantially absorbed in the retina, this wavelength range is known as the eye safe window. For wavelengths longer than 1400nm, in general only the cornea of the eye may receive or absorb the light radiation. Thus, for example, wavelengths near 1210nm do not fall in the eye safe window, while wavelengths near 1720nm are within the eye safe window. Although the pump lasers or intermediate orders in the laser system may not fall within the eye safe wavelength range, these wavelengths may be substantially blocked or filtered within the laser unit. Consequently, to achieve an eye safe laser even operating at a wavelength such as 1720nm, the residual intermediate and pump wavelengths should be substantially filtered before the fiber or free space output.

#### 45 *Mid-Infrared Fiber Lasers*

**[0030]** As an example, FIGURES 6 and 7 illustrate that there could be novel selective damage to tissue constituents or spectroscopy to detect particular tissue constituents, which could lead to novel medical diagnostics or therapeutics. In one embodiment, relatively narrow band lasers can be constructed near 1210nm or 1720nm by using cascaded Raman oscillators. These lasers could be beneficial for therapeutic medical procedures and can generate relatively high spectral density at wavelengths of interest. In another embodiment, super-continuum (SC) light sources or lasers can be implemented that can be broadband in the mid-infrared wavelength range and

that could be beneficial for diagnostic medical procedures. The broadband light can be helpful for procedures based on spectroscopy, which, for example, can rely on the wavelength characteristics of different constituents to identify the constituents' presence through an algorithm such as spectral fingerprinting. Below some examples of cascaded Raman oscillators and super-continuum light sources are provided, along with examples of fiber lasers based on single-mode or double-clad fibers. These are exemplary mid-infrared fiber lasers, but other mid-infrared lasers, such as solid state lasers or semiconductor lasers, can also be used consistent with this disclosure.

**[0031]** In one embodiment, a mid-infrared laser can be constructed by using a pump fiber laser to generate a pump signal, and then to wavelength shift the pump signal to a longer wavelength using a cascaded Raman oscillator. In a preferred embodiment, the cascaded Raman oscillator can be a fiber surrounded by a plurality of gratings. As an example, the fiber laser can be a ring laser cavity or a linear laser cavity. For example, a ring laser cavity can be made with couplers surrounding a gain fiber. In another example, a linear laser cavity can comprise one or more optical gratings surrounding a gain fiber. In a preferred embodiment, the gain fiber can be a doped fiber, such as a ytterbium-doped fiber, an erbium-doped fiber, an erbium/ytterbium doped fiber, or a thulium doped fiber. Also, higher powers can be generated by using a gain fiber that is a cladding pumped fiber or a double clad fiber. Alternatively, the gain fiber could potentially be a photonic crystal fiber. Although particular examples are provided for doping and fiber types, different combinations or alternatives can be used consistent with this disclosure.

**[0032]** FIGURE 8 illustrates a block diagram of one embodiment of a mid-infrared fiber laser 800 operating near 1720nm. One advantage of such a configuration can be that all of the fiber parts can be spliced together to result in an all-fiber, monolithically integrated, no moving parts light source. In this particular example, the pump fiber laser 804 can be a cladding pumped fiber amplifier 801 with a feedback loop 802 around the amplifier to cause lasing. In one non-limiting example, an isolator 803 can be placed in the ring cavity of the pump laser to cause the lasing to be unidirectional. In this case, the cladding pumped fiber amplifier 801 can be an erbium/ytterbium doped amplifier operating near 1550nm. The pump laser light can then be coupled to a cascaded Raman oscillator 805, where the fiber 806 can be a single-mode fiber and two sets of Bragg gratings 807 can be used to wavelength shift out to near 1720nm.

**[0033]** In one embodiment, a specific example of the mid-infrared fiber laser operating at approximately 1708nm is shown in detail in FIGURE 9. The top part of the figure illustrates one embodiment of the pump fiber laser 900 details, while the bottom part of the figure illustrates one embodiment of the cascaded Raman oscillator 950 details. In the pump fiber laser, the gain fiber 901

can exemplary be an erbium-ytterbium doped, double clad fiber. In one embodiment, the length of the gain fiber can be between 3 and 6 meters. One or more pump laser diodes 902 can be used to excite the gain fiber 901. In one embodiment, the pump lasers 902 can operate at wavelengths between approximately 935nm and 980nm, and between 2 and 18 pump laser diodes may be used. The one or more pump laser diodes 902 can be combined using a power combiner 903, and then the combined pump laser diode power can be coupled to the gain fiber 901. In this particular example, the pump laser diodes 902 can be coupled into the gain fiber 901 in a counter-propagating direction to the signal in the oscillator. However, the pump laser diodes could also co-propagate with the direction of the signal in the oscillator. After the pump combiner 903, a part of the output of the gain fiber can be separated at a power tap 904 and then feed back to the input using a feedback loop fiber 907. In the loop, an isolator 905 can also be inserted to permit unidirectional operation and lasing (in this particular example, the pump fiber laser 900 resonates in a counter-clockwise direction). Other elements may also be inserted into the ring cavity, such as additional taps 906. Although one particular example of a pump fiber laser 900 is described, any number of changes in elements or their positions can be made consistent with this disclosure. For example, the pump laser can be a high powered semiconductor laser, a solid state laser, a nonlinear crystal laser, or any combination of these.

**[0034]** The bottom of FIGURE 9 illustrates one embodiment of a cascaded Raman oscillator 950 for shifting the pump fiber laser output wavelength to a longer signal wavelength 951. The center of the oscillator is a Raman gain fiber 952, which in this particular embodiment can be a standard single mode fiber SMF. The length of the SMF can be in the range of 300m to 10km, and as an example in this embodiment may be closer to approximately 5km. Any number of fiber types, including high nonlinearity fibers, mid-infrared fibers, high numerical aperture fibers, or photonic crystal fibers, can be used consistent with this disclosure. The Raman gain fiber 952 can be surrounded by a plurality of fiber Bragg gratings FBG, 953, 954 and 955. In this particular embodiment, two cascaded Raman orders are used to transfer the pump output wavelength 908 near 1550nm to the longer signal wavelength near 1708nm. Hence, in FIGURE 9 there can be two sets of fiber Bragg gratings.

**[0035]** As an example, the inner grating set 953 can be designed to provide high reflectivity near 1630nm. The reflectivity can be in the range of 70 to 90 percent, and in this particular embodiment can be closer to 98%. The outer grating set 954 and 955 can be designed to reflect light near 1708nm (i.e., the desired longer signal wavelength). The first fiber Bragg grating 954 can have high reflectivity, for example in the range of 70 to 90 percent, more preferably closer to 98%. The second fiber Bragg grating 955 also serves as the output coupler, and hence should have a lower reflectivity value. As an example,

the reflectivity of grating 955 can be in the range of 8 to 50 percent, more preferably closer to 12%.

**[0036]** Moreover, to remove the residual shifted pump light from the first or intermediate orders of Raman shifting, WDM couplers can be used surrounding the oscillator, such as 956 and 957. In this particular embodiment, the WDM couplers 956 and 957 are 1550/1630 couplers (i.e., couplers that pass light near 1550nm but that couple across or out wavelengths near 1630nm). Such couplers can help to avoid feedback into the pump fiber laser 900 as well as minimize the residual intermediate orders in the longer signal wavelength 951. It may also be beneficial to add an isolator between the pump fiber laser 900 and the cascaded Raman oscillator 950 to minimize the effects of feedback. Although one specific example is provided for the cascaded Raman oscillator 950, any number of changes in the components or values or additional components can be made and are intended to be covered in this disclosure.

**[0037]** FIGURE 10A illustrates a block diagram of yet another embodiment of a mid-infrared fiber laser 1000 that operates near 1212nm. Whereas FIGURES 8 and 9 use a ring cavity pump fiber laser, FIGURE 10 uses a linear cavity pump fiber laser. Either of these configurations or other versions of the pump fiber laser can be used consistent with this disclosure. In this particular example, the pump fiber laser 1004 can be a cladding pumped fiber amplifier 1001 surrounded by fiber Bragg gratings 1002 and 1003 around the amplifier to cause lasing. In this case, the cladding pumped fiber amplifier 1001 can be a ytterbium doped amplifier operating approximately in the wavelength range between 1050 and 1120nm. The pump laser light can then be coupled to a cascaded Raman oscillator 1005, where the fiber 1006 can be a single-mode fiber and two sets of Bragg gratings 1007 are used to wavelength shift out to near 1212nm.

**[0038]** In yet another embodiment, a specific example of the mid-infrared fiber laser operating at approximately 1212nm is shown in detail in FIGURE 10B. The top part of the figure illustrates one embodiment of the pump fiber laser 1050 details, while the bottom part of the figure illustrates one embodiment of the cascaded Raman oscillator 1075 details. In the pump fiber laser, the gain fiber 1051 can exemplarily be a ytterbium doped, double clad fiber. In one embodiment, the length of the gain fiber can be between 3 and 10 meters. One or more pump laser diodes 1052 can be used to excite the gain fiber 1051. In one embodiment, the pump lasers 1052 can operate at wavelengths between approximately 850nm and 980nm, and between 2 and 18 pump laser diodes may be used. The one or more pump laser diodes 1052 can be combined using a power combiner 1053, and then the combined pump laser diode power can be coupled to the gain fiber 1051. After the pump combiner 1053, it may be beneficial to use one or more isolators 1055 to avoid feedback into the pump laser diodes 1052.

**[0039]** The pump fiber laser can be formed by using a set of gratings 1054 and 1056 around the gain fiber 1051.

In one embodiment, the fiber Bragg gratings 1054 and 1056 can have reflecting at a wavelength near 1105nm. The reflectivity of 1054 can be in the range of 70 to 90 percent, and in this particular embodiment can be closer to 98%. The second fiber Bragg grating 1056 can also serve as the output coupler, and hence may have a lower reflectivity value. As an example, the reflectivity of grating 1056 can be in the range of 5 to 50 percent, more preferably closer to 10%. Other elements may also be inserted into the linear resonator cavity, such as additional taps. Although one particular example of a pump fiber laser 1050 is described, any number of changes in elements or their positions can be made consistent with this disclosure.

**[0040]** The bottom of FIGURE 10B illustrates one embodiment of a cascaded Raman oscillator 1075 for shifting the pump fiber laser output wavelength to a longer signal wavelength 1076. The center of the oscillator is a Raman gain fiber 1077, which in this particular embodiment can be a HI-1060 fiber, which operates at a single spatial mode at the wavelengths of the ytterbium amplifier. The length of the Raman gain fiber 1077 can be in the range of 300m to 10km, and as an example in this embodiment may be closer to approximately 1km. Any number of fiber types, including high nonlinearity fibers, mid-infrared fibers, high numerical aperture fibers, or photonic crystal fibers, can be used consistent with this disclosure. The Raman gain fiber 1077 can be surrounded by a plurality of fiber Bragg gratings FBG, 1078, 1079 and 1080. In this particular embodiment, two cascaded Raman orders are used to transfer the pump output wavelength 1057 near 1105nm to the longer signal wavelength near 1212nm. Hence, in FIGURE 10B there can be two sets of fiber Bragg gratings.

**[0041]** As an example, the inner grating set 1078 can be designed to provide high reflectivity near 1156nm. The reflectivity can be in the range of 70 to 90 percent, and in this particular embodiment can be closer to 99%. The outer grating set 1079 and 1080 can be designed to reflect light near 1212nm (i.e., the desired longer signal wavelength). The first fiber Bragg grating 1079 can have high reflectivity, for example in the range of 70 to 90 percent, more preferably closer to 99%. The second fiber Bragg grating 1080 can also serve as the output coupler, and hence may have a lower reflectivity value. As an example, the reflectivity of grating 1080 can be in the range of 8 to 50 percent, more preferably closer to 25%.

**[0042]** Moreover, to remove the residual shifted pump light from the first or intermediate orders of Raman shifting, WDM couplers can be used surrounding the oscillator, such as 1081 and 1082. In this particular embodiment, the WDM couplers 1081 and 1082 are 1100/1160 couplers (i.e., couplers that pass light near 1100nm but that couple across or out wavelengths near 1160nm). Such couplers can help to avoid feedback into the pump fiber laser 1050 as well as minimize the residual intermediate orders in the longer signal wavelength 1076. It may also be beneficial to add an isolator between the

pump fiber laser 1050 and the cascaded Raman oscillator 1075 to minimize the effects of feedback. Although one specific example is provided for the cascaded Raman oscillator 1075, any number of changes in the components or values or additional components can be made and are intended to be covered in this disclosure.

#### *Super-Continuum Light Sources Or Lasers*

**[0043]** The cascaded Raman oscillators, such as in FIGURES 8-10, can be particularly useful when significant power is desired in a relatively narrow bandwidth, such as for use in a therapeutic procedure. On the other hand, it can be valuable to have a broadband source or a tunable source to observe either through absorption or reflection of the spectral features associated with a particular type of tissue, such as might be done in a diagnostic procedure. A super-continuum (SC) light source or laser can be used for generating broadband light. In an SC laser, a MOPA (master oscillator optical amplifier) type configuration can be used for pumping, which can comprise a seed laser followed by optical amplifiers to boost the power. Then, the broadband light can be generated in an optical fiber using the nonlinear mechanisms in the fiber. For wavelengths shorter than about 2.6 microns, fused silica fibers can be used for SC generation, such as standard single-mode fiber, high-nonlinearity fiber, high-NA fiber, dispersion shifted or dispersion compensating fiber. For wavelengths extending beyond 2.6 microns, the SC generation can be achieved in a mid-infrared fiber, such as fluorides, chalcogenides, ZBLAN, tellurite or germanium oxides.

**[0044]** FIGURE 11A illustrates a block diagram of one embodiment of a mid-infrared SC fiber laser 1100. In this example, the pump laser comprises a seed laser diode 1101 followed by several stages of amplification in fiber amplifiers 1102 and 1105. Then, the SC can be generated in this embodiment in a standard single-mode fiber 1106 followed by a mid-infrared ZBLAN fiber 1108. The output 1109 from this source can range in power up to about 10W or 40W time averaged power, and the spectral width at the output can range between approximately 800nm and 4500nm. As another example, if the super-continuum fiber 1108 is instead a fused silica fiber, then the range of the super-continuum can range from approximately 1600 to 1800nm in one embodiment. The seed laser diode 1101 can be a telecom-grade, distributed feedback laser diode operating in the telecom band, which can span for instance 1500 to 1600nm. The pre-amplifier 1102 can be made in a single-mode erbium-doped fiber amplifier. The power amplifier 1105 can generate relatively high powers by using a doped cladding-pumped or double clad amplifier fiber, doped for example with erbium/ytterbium. Although two stages of amplification are shown in FIGURE 11A, any number of stages can be used, including adding one or more stages of intermediate amplifiers. Also, it can be advantageous to place band-pass filters 1103 and isolators 1104 between

amplifier stages to control the background noise level and to avoid feedback into the amplifiers.

**[0045]** A particular example of a mid-infrared SC laser 1150 that can generate relatively high powers is illustrated in FIGURE 11B. In one embodiment, a 10 mW distributed feedback (DFB) laser diode 1151 emitting at 1542 nm can be driven by electronic circuits 1152 to provide 400 ps to 2 ns pulses at variable repetition rates. The electronic circuits 1152 can also drive the laser diode to output a pre-programmed pulse pattern instead of fixed repetitive pulses. Also, in this example the optical pulses can be amplified by three stages of fiber amplifiers—an erbium-doped fiber amplifier (EDFA) pre-amplifier 1154 followed by erbium/ytterbium doped fiber amplifier (EYFA) mid-stage 1155 and power amplifiers 1156. In one embodiment, the pre-amplifier can use a length of single mode erbium doped gain fiber 1157, where the length may be between 0.5m and 5m, preferably close to 1m in length. In this embodiment, the mid-stage amplifier 1155 can employ a length of larger core cladding-pumped gain fiber 1158, where the length can be between 0.5 and 5m, preferably close to 1.5m in length. The EDFA 1157 can be co-propagation or forward pumped using a pump laser diode 1162, preferably operating around 980nm. The cladding pumped EYFA 1158 can also be counter-propagation or backward pumped with a laser diode 1163, preferably operating between 935nm and 980nm.

**[0046]** In a multi-stage amplifier such as 1155, the noise performance, i.e. amplified spontaneous emission (ASE), can be determined by the upstream stages before the power amplifier. To lower the ASE, it can be advantageous to separate the amplifier into a pre-amplifier 1157 and a mid-stage amplifier 1158. Therefore, the ASE after the first stage can be filtered by a bandpass filter 1159, such as a 100 GHz filter, and the signal gain in each amplifier stage can be reduced. Optical isolators 1160 and 1161 are also advantageously placed between the stages to protect the system from back-reflection damage as well as reduce the noise figure and improve the efficiency of the combined amplifier system. In one preferred embodiment, a ~20 dB gain can be obtained in both the pre- and mid-amplifier for the optical signal while the ASE-to-signal ratio can be measured to be less than 1%. The nonlinear broadening of the optical pulses before the power amplifier can also be negligible. In addition, an optical tap may be used to sample the output power of the pre-amplifier and to enable the signal feedback control 1153.

**[0047]** In one particular embodiment, the power from the mid-amplifier 1155 is boosted in an all-fiber-spliced, cladding-pumped, EYFA 1156 or 1164 before coupling into the SC fiber 1167 and 1169. A cladding-pumped fiber amplifier 1164 can be advantageously used to increase the gain volume and enable the coupling of multiple pump diodes 1166. In addition, to minimize the nonlinear effects in the amplifier, a short length of gain fiber with a large core diameter and a high doping concentration can be used.

**[0048]** In one embodiment of a 10 W SC generation experiment, the gain fiber 1164 is designed with a core diameter of between 8 to 25 microns, preferably around 15  $\mu\text{m}$ , and an effective NA in the range of 0.1 to 0.2, preferably closer to 0.15; thus, the mode field size can be close to that of the SMF fiber. The EYFA 1164 can be several meters in length, as an example ~5 m in length. In one embodiment, ten 8 W 976 nm and two 8 W 940 nm uncooled multimode pump diodes 1166 can be coupled into the gain fiber through an  $18\times 1$  pump combiner 1165. Single spatial mode operation can be maintained in the EYFA by carefully splicing the gain fiber to the signal-input SMF fiber and the pump combiner. In this example, the output spectrum after the SMF fiber can be broadened and red-shifted to ~2.2  $\mu\text{m}$  primarily due to the break-up of the nanosecond pulses through modulation instability (MI) followed by soliton self-frequency shifting. In another embodiment, a 12/130  $\mu\text{m}$  core/cladding diameter erbium/ytterbium co-doped fiber with a 0.20 NA can be used as the gain fiber 1164 in the final stage power amplifier 1156.

**[0049]** As a particular example, the SC output 1170 can be generated in a two-stage process. In the first stage SMF fiber 1167, modulation instability (MI) can be utilized to break up the nanosecond pulses into femtosecond pulse trains to enhance the nonlinear optical effects and red-shift the optical spectrum to beyond 2  $\mu\text{m}$ . The SC spectrum can then be broadened in the following ZBLAN fiber 1169 through the interplay of self-phase modulation, Raman scattering and parametric four-wave mixing.

**[0050]** In one embodiment, the SC can be generated by butt coupling 1168 the light from the 2 m length of SMF fiber 1167 after the EYFA into a piece of ZBLAN fluoride fiber 1169. Two ZBLAN fluoride fibers have been used exemplary in the experiments. In the 10.5 W high power SC experiment, the ZBLAN fiber 1169 can be 7 m long and can have a core diameter of 8.9  $\mu\text{m}$ , a cladding diameter of 125  $\mu\text{m}$  and an NA of 0.21. In another example, the ZBLAN fiber 1169 can have a length of ~15 m with a core diameter of 10.6  $\mu\text{m}$ , a cladding diameter of 125  $\mu\text{m}$  and an NA of 0.2. Advantageously, all ends of SMF 1167 and ZBLAN 1169 fibers can be angle-cleaved to avoid light back reflected into the pump system. Although one particular example of mid-infrared SC generation has been shown in FIGURE 11, any number of elements can be added or positions changed or parameter values changed consistent with this disclosure.

**[0051]** The configuration of FIGURE 11 can lead to broadband light covering several octaves, exemplary from about 800nm to approximately 4500nm. However, narrower bandwidth SC may in some cases be desired at wavelengths shorter than about 2.5 microns. Several examples of SC sources are illustrated in FIGURE 12A. The top SC source of FIGURE 12A can lead to bandwidths ranging from about 1400nm to 1800nm or broader, while the lower SC source of FIGURE 12A can lead to bandwidths ranging from about 1900nm to 2500nm or broader. Since these wavelength ranges are shorter than

about 2500nm, the SC fiber can be based on fused silica fiber. Exemplary SC fibers include standard single-mode fiber SMF, high-nonlinearity fiber, high-NA fiber, dispersion shifted fiber, dispersion compensating fiber, and photonic crystal fibers. Non-fused-silica fibers can also be used for SC generation, including chalcogenides, fluorides, ZBLAN, tellurites, and germanium oxide fibers.

**[0052]** In one embodiment, the top of FIGURE 12A illustrates a block diagram for an SC source 1200 capable of generating light exemplary between approximately 1400 and 1800nm or broader. As an example, a pump fiber laser similar to FIGURE 11 can be used as the input to a SC fiber 1209. The seed laser diode 1201 can comprise a DFB laser that generates, exemplary, several milli-watts of power around 1553nm. The fiber pre-amplifier 1202 can comprise an erbium-doped fiber amplifier. In this example a mid-stage amplifier 1203 can be used, which can comprise an erbium/ytterbium doped double-clad fiber. A bandpass filter 1205 and isolator 1206 may be used between the pre-amplifier 1202 and mid-stage amplifier 1203. The power amplifier stage 1204 can comprise a larger core size erbium/ytterbium doped double-clad fiber, and another bandpass filter 1207 and isolator 1208 can be used before the power amplifier 1204. The output of the power amplifier can be coupled to the SC fiber 1209 to generate the SC output 1210. This is just one exemplary configuration for an SC source, and other configurations or elements can be used consistent with this disclosure.

**[0053]** In yet another embodiment, the bottom of FIGURE 12A illustrates a block diagram for an SC source 1250 capable of generating light exemplary between approximately 1900 and 2500nm or broader. As an example, the seed laser diode 1251 can comprise a DFB or DBR laser that generates, exemplary, several milli-watts of power around 1553nm. The fiber pre-amplifier 1252 can comprise an erbium-doped fiber amplifier. In this example a mid-stage amplifier 1253 can be used, which can comprise an erbium/ytterbium doped double-clad fiber. A bandpass filter 1255 and isolator 1256 may be used between the pre-amplifier 1252 and mid-stage amplifier 1253. The power amplifier stage 1254 can comprise a thulium doped double-clad fiber, and another isolator 1257 can be used before the power amplifier 1254. Note that the output of the mid-stage amplifier 1253 can be approximately near 1553nm, while the thulium-doped fiber amplifier 1254 can amplify wavelengths longer than approximately 1900nm and out to about 2100nm. Therefore, for this configuration wavelength shifting may be required between 1253 and 1254. In one embodiment, the wavelength shifting can be accomplished using a length of standard single-mode fiber 1258, which can exemplary have a length between approximately 5 and 50 meters. The output of the power amplifier 1254 can be coupled to the SC fiber 1259 to generate the SC output 1260. This is just one exemplary configuration for an SC source, and other configurations or elements can be used consistent with this disclosure. For example, the various

amplifier stages can comprise different amplifier types, such as erbium doped fibers, ytterbium doped fibers, erbium/ytterbium co-doped fibers and thulium doped fibers. One advantage of the SC lasers illustrated in Figures 11 and 12 are that they may use all-fiber components, so that the SC laser can be all-fiber, monolithically integrated with no moving parts. The all-integrated configuration can consequently be robust and reliable.

**[0054]** As yet another example of a mid-infrared light source that can generate light around 1720nm to 1800nm, FIGURE 12B illustrates a thulium doped cladding-pumped fiber laser, along with the absorption and emission bands for thulium-doped fibers. The top left side of FIGURE 12B shows an exemplary absorption spectrum 1270 for thulium doping in a single-mode silica fiber. As an example, one efficient band 1271 to pump the fiber can be around 790nm, where high-power semiconductor pump lasers are available. The top right side 1275 of FIGURE 12B illustrates the absorption cross-section 1276 and emission cross-section 1277 for a typical thulium doped fiber in the wavelength range between 1400nm and 2000nm. As 1275 shows, the cross-over wavelength where the absorption and emission intersect 1278 can be approximately 1720nm, and this can mean that a thulium-doped fiber laser could potentially be made between approximately 1720nm and 2100nm.

**[0055]** In a preferred embodiment, a thulium-doped fiber laser 1280 can be implemented as illustrated in the bottom of FIGURE 12B for mid-infrared selective damage. One or more pump laser diodes 1281 can be used, where the pump laser diode wavelengths can be near the absorption band 1271 around 790nm. The pump lasers can be combined using a pump combiner 1282, and then the combined light can be coupled to the gain fiber 1286. Optionally, one or more isolators or spectral filters 1283 can be used to minimize feedback into the pump laser diodes 1281. The gain fiber 1286 can be a thulium-doped fiber amplifier, and in one preferred embodiment the gain fiber 1286 can be a double-clad fiber or a cladding-pumped fiber. The resonator 1280 can be formed by placing reflectors surrounding the gain fiber 1286, where the reflector on the left (e.g., 1284) can transmit the pump wavelengths but reflect the lasing output wavelength 1287. The reflector on the right (e.g., 1285) can also serve as the output coupler and should be at least partially transmitting and partially reflecting at the lasing output wavelength 1287. In the particular embodiment to FIGURE 12B, a fiber Bragg grating 1284 can be used on the left side, and another fiber Bragg grating 1285 that also serves as the output coupler can be used on the right side of the cavity surrounding the gain fiber 1286. Although one embodiment of a thulium-doped fiber laser 1280 is illustrated in FIGURE 12B, the various elements in the configuration can be placed at alternative locations, and other elements may also be added or removed from this configuration consistent with this disclosure.

**[0056]** In one particular example, it may be advantageous to have the thulium-doped fiber laser 1280 operate

at wavelengths near 1720nm or out to 1750nm, such as when the absorption in adipose, collagen and/or elastin have a local maximum. Since these wavelengths are close to the cross-over 1278 between absorption and emission in thulium, several additional procedures or elements may be considered for the laser 1280 so as to push the wavelengths to shorter than approximately 1750nm. In one embodiment, a shorter gain fiber may be used, and the pump power can be maintained fairly high through the gain fiber to nearly fully invert the gain fiber. For example, a nearly fully inverted gain fiber will have more emission than absorption. In another embodiment, the fiber Bragg grating 1284 and 1285 reflecting wavelengths can be selected at the shorter wavelengths desired. Moreover, the output coupling ratio for the output coupler 1285 may be selected to optimize lasing at the shorter wavelengths. In yet another embodiment, a lossy element may be introduced into the laser cavity 1280, wherein the lossy element has a higher loss at the longer wavelengths such as 1750-2100nm and lower loss at the shorter wavelengths such as 1700-1750nm. In a further embodiment, bends may be introduced on sections of the fiber in the laser cavity 1280 to introduce bend-induced loss, since it is known that bend-induced loss usually increases with increasing wavelength. In an alternative embodiment, a seed laser signal may be introduced toward the shorter wavelengths around 1720-1750nm, thereby effectively decreasing the loss at these wavelengths. Any one of these or combinations of these techniques may be used to cause the thulium-doped fiber oscillator 1280 to operate in the wavelengths closer to 1720 to 1750nm.

**[0057]** Based on the scattering through tissue and water absorption shown for example in FIGURES 4 and 5, one advantage of using wavelengths near 1210nm or 1720nm can be the deeper penetration depths that can be achieved. To explore this advantage, the fiber laser configuration of FIGURE 9 was exemplary used on in vitro human skin tissue samples. In one embodiment, FIGURE 13 illustrates the depth of damage 1301 obtained in the in-vitro human skin samples plotted as a function of laser fluence at 1708nm incident on the skin sample. The curve 1301 shows that the damage depth can increase with increased fluence at 1708nm, and that the penetration depth can approach approximately 1.4mm in the skin sample. Thus, some of the advantages of using mid-infrared wavelengths can be demonstrated using the various laser configurations of FIGURES 8 through 12.

**[0058]** Although cascaded Raman wavelength shifters, fiber lasers, and super-continuum lasers have been described as some exemplary lasers for generating mid-infrared light between approximately 1 and 10 microns, a myriad of other laser systems exist and are intended to be included within the scope of this disclosure. In one embodiment, different combinations of the laser such as described in FIGURES 8 through 12 can be used beneficially. For instance, the output from a cascaded Raman

wavelength shifter operating near 1210nm can be combined with the output from a cascaded Raman wavelength shifter operating near 1720nm. One benefit of such a combination might be that different penetration depths into a biological tissue can be obtained using the different wavelengths. In another embodiment, it may be advantageous to combine one or more cascaded Raman wavelength shifters with one or more super-continuum lasers. For example, one advantage of such a configuration may be the ability for the laser system to perform both diagnostics and therapeutic procedures. In addition, different types of optical amplifiers and fibers can be used in the different configurations such as shown in FIGURES 8-12. Optical amplifier materials include fibers doped with different constituents, such as erbium, ytterbium, and thulium or co-doped materials such as erbium/ytterbium. Also, different kinds of fibers can be used in any of these configurations, and exemplary fibers can be made at least in part from fused silica, chalcogenides, fluorides, telluride, ZBLAN, photonic crystal fibers, etc.

**[0059]** Alternative laser systems can also be used for mid-infrared light generation. For example, other types of fiber lasers can be used, including modelocked lasers, MOPA or master oscillator followed by amplifiers, and fiber oscillators. In one embodiment, solid state lasers can be used that comprise materials including thulium, holmium, erbium, prysadinium, ytterbium, and chromium. In another embodiment, different types of semiconductor lasers can be used, including optically pumped semiconductor lasers, lead-salt diode lasers, antimonide diode lasers, lasers based on III-IV and II-VI semiconductor materials, as well as intra-band lasers, such as quantum cascade lasers. In yet another embodiment, gas lasers may be used, including carbon dioxide and carbon monoxide lasers. In a further embodiment, mid-infrared light sources can be based on nonlinear frequency conversion, such as optical parametric oscillators and amplifiers, difference frequency generation and parametric frequency conversion. As an example, such nonlinear frequency conversion techniques can use quasi-phase matched materials, including periodically-poled lithium niobate PPLN, gallium arsenide GaAs, lithium tantalite, and ferroelectric crystals of the potassium titanyl phosphate family. These mid-infrared lasers as well as any combinations of these can be used in the exemplary medical procedures described below.

#### *Laser Beam Output Parameters*

**[0060]** The laser beam output that may be used in the healthcare, medical or bio-technology applications can have a number of parameters, including wavelength, energy or fluence, spatial spot size, and pulse temporal shape and repetition rate. Some exemplary ranges for these parameters and some of the criteria for selecting the ranges are discussed below. These are only meant to be exemplary ranges and considerations, and the particular combination used may depend on the details and

goals of the desired procedure.

**[0061]** Whereas it may be advantageous in a diagnostic procedure to use a broadband laser such as a super-continuum source, for various therapeutic procedures the wavelength for the laser may be selected on the basis of a number of considerations. In one embodiment, for selective damage it may be advantageous to reduce or minimize the absorption due to water and blood as well as scattering through tissue. As an example, from FIGURE 5 advantageous windows can be from 1200 to 1350nm or 1600 to 1800nm.

**[0062]** In another embodiment, it may be advantageous to tune the wavelength to near an absorption peak in a particular type of tissue. For example, FIGURES 6 and 7 illustrate that wavelengths near 1210nm or 1720nm can coincide with local absorption maxima for adipose, collagen and elastin. Also, from FIGURES 6 and 7 it can be seen that the wavelength window near 1720nm falls near a local minimum in water absorption and scattering loss. In one embodiment, having lower water absorption and scattering loss, such as near 1720nm, can advantageously permit deeper penetration of the laser light into the tissue. For example, near 1720nm the penetration depth into skin or typical tissue may be in the range between 0.5mm to several millimeters, up to perhaps 3 to 4 millimeters. As one example, FIGURE 13 illustrates that light near 1708nm can penetrate approximately 1.4mm in skin tissue.

**[0063]** In yet another embodiment, it may be advantageous to have the laser wavelength fall in the so-called eye-safe wavelength range. For instance, wavelengths longer than approximately 1400nm can fall within the eye safe window. So, from an eye safety consideration there may be an advantage of using the wavelength window near 1720nm rather than the window near 1210nm. Thus, some of the considerations in selecting the laser wavelength range from selective tissue absorption, water absorption and scattering loss, penetration depth into tissue and eye safe operation. From a combination of these criteria, the wavelength near 1720nm may be particularly advantageous for selectively damaging adipose, collagen and elastin. However, other criteria or considerations may also be used in selecting the particular wavelength, and in this disclosure the wavelengths near 1720nm are merely selected as a non-limiting example. For instance, a combination of 1210nm and 1720nm may be used to obtain different penetration depths or to control the power density profile into the dermis or other tissue.

**[0064]** Another parameter for the laser can be the energy, fluence, or pulse power density. The fluence is the energy per unit area, so it can have the units of Joules/cm<sup>2</sup>. As an example, in dermatological applications it can be advantageous to use fluences less than approximately 250J/cm<sup>2</sup> to avoid burning or charring the epidermis layer. As illustrated in FIGURE 13, diagnostic procedures may benefit from having fluences less than about 50J/cm<sup>2</sup>, while therapeutic procedures may benefit from having fluences in the range of approximately 30 to

250J/cm<sup>2</sup>, preferably in the range of 50 to 200J/cm<sup>2</sup>. In another embodiment, it may even be advantageous to use lower fluence levels for therapeutic procedures to impart less pain to patients, for example in the range of approximately 30J/cm<sup>2</sup> or less. These types of fluence levels may typically correspond to time averaged powers from the laser exceeding approximately 10W, preferably in the power range of 10 to 30W, perhaps as high as 50W or more. Although particular fluence and power ranges are provided by way of example, other powers and fluences can be used consistent with this disclosure.

**[0065]** Although the output from a fiber laser may be from a single or multi-mode fiber, different spatial spot sizes or spatial profiles may be beneficial for different applications. For example, for applications where adipose tissue may be damaged around an organ, it may be advantageous to either collimate or focus the laser light onto the adipose. In one embodiment, it may also be beneficial to have a line scan rather than individual laser spots exposing the adipose tissue. On the other hand, for applications such as dermatology or where light may be exposed onto an external part of the body, it may be desirable to have a collimated or expanded beam size. To expand and/or collimate the beam, one or more lenses or curved mirrors may be used after the delivery fiber. In one example, the beam waist or spot size can be 3mm or more, preferably 1cm or even larger. The larger spot sizes can permit faster procedure times. For example, a spot size with a diameter in the range of 3mm to 1cm can lead to scanning over a patients face within 15 minutes by a dermatologist. In yet another embodiment, although the output from a fiber is typically a Gaussian-shaped profile, it may be advantageous to have a spatial beam shape that is more square-like. As an example, the square-like spatial mode can be achieved by using an aperture at the output of the fiber and blocking the wings of the Gaussian-like beam. One reason that the square-like beam shape may be desirable is that it can have a more uniform light intensity across the beam. Another advantage of the square-like beam may be that the area of the body that is to be treated can be set up or marked as a grid, and then the laser beam can be moved from one grid location to another. Although particular spatial mode shapes and sizes have been described, any number of other shapes and sizes may be used consistent with this disclosure.

**[0066]** Various types of damage mechanisms are possible in biological tissue. In one embodiment, the damage may be due to multi-photon absorption, in which case the damage can be proportional to the intensity or peak power of the laser. For this embodiment, lasers that produce short pulses with high intensity may be desirable, such as the output from modelocked lasers. Alternative laser approaches also exist, such as Q-switched lasers, cavity dumped lasers, and active or passive modelocking.

**[0067]** In another embodiment, the damage may be related to the optical absorption in the material, such as

the optical absorption curves illustrated in FIGURES 1 through 7. For this embodiment, the damage can be proportional to the fluence or energy of the pulses, perhaps also the time-averaged power from the laser. The laser power may be absorbed in the particular tissue types, such as adipose, collagen and elastin, and the absorbed energy may then lead to heating within the tissue. For this example, continuous wave, pulsed, or externally modulated lasers may be used, such as those exemplified in FIGURES 8 through 12. In one embodiment, laser pulses that are longer than approximately 100 nanoseconds to as long as 10 seconds or longer may be employed.

**[0068]** Particularly in the example when the damage may be related to the optical absorption, it may be beneficial to also consider the thermal diffusion into the surrounding tissue. As an example, the thermal diffusion time into tissue may be in the millisecond to second time range. Therefore, for pulses shorter than about several milliseconds, the heat may be generated locally and the temperature rise can be calculated based on the energy deposited. On the other hand, when longer pulses that may be several seconds long are used, there can be adequate time for thermal diffusion into the surrounding tissue. In this example, the diffusion into the surrounding tissue should be considered to properly calculate the temperature rise in the tissue. For these longer pulses, the particular spot exposed to laser energy will reach closer to thermal equilibrium with its surroundings. In one embodiment corresponding to the data in FIGURE 13, pulse widths of approximately 3sec to 10sec have been used. The local temperature achieved can also be affected by cooling. As described in the next section, when a cold window or cryo-spray is used, the cooling can remove heat from the top surface of the exposed tissue. Even with surface cooling, the laser power level may be adjusted so the heating depth reaches the area of interest while the cooling protects the regions above this area. Moreover, another adjustable parameter for the laser pulses may be the rise and fall times of the pulses. However, these may be less important when longer pulses are used and the damage is related to the energy or fluence of the pulses.

**[0069]** Beyond having a pulse width, the laser output can also have a preferred repetition rate. For pulse repetition rates above around 10MHz, where multiple pulses fall within a thermal diffusion time, the tissue response may be more related to the energy deposited or the fluence of the laser beam. The separation between pulses or a sub-group of pulses may also be selected so that the tissue sample can reach thermal equilibrium between pulses. Also, the pulse pattern may or may not be periodic. In one embodiment, there may be several pulses used per spot, where the pulse pattern is selected to obtain a desired thermal profile. The laser beam may then be moved to a new spot and then another pulse train delivered to that spot. In one embodiment, there can be several seconds of pre-cooling, the laser can be exposed

on the tissue for several seconds, and then there may also be post-cooling. Although particular examples of laser duration and repetition rate are described, other values may also be used consistent with this disclosure.

*Laser Beam Delivery, Cooling And Fractionated Beam*

**[0070]** A laser beam delivery assembly can advantageously be coupled to the mid-infrared laser, such as those shown in FIGURES 8-12. The design of the laser beam delivery system can be tailored to the ergonomic and comfortable usage by a medical practitioner. For example, there can be handles for easy gripping, switches or triggers that can be controlled by foot or fingers, and a flexible cord connecting the delivery head to the laser system. In one embodiment, the flexible cord can comprise a single-mode or multi-mode fiber, which may be used to couple the laser output to the delivery head or output port of the delivery assembly. The fiber in the flexible cord may be coupled using a connector to the laser output, and this can have the advantage that any damage in the delivery fiber may not require replacing the fiber in the laser system. Also, by using such a flexible cord and fiber assembly, the laser system can be located remotely from the delivery arm, such as under a table or on the floor, perhaps even in a different room than where the procedure is performed. In one preferred embodiment, a visible wavelength beam, such as from a helium neon laser, a light emitting diode or a semiconductor laser diode, may also be coupled to the delivery fiber. Since the mid-infrared wavelengths are not easily viewed by the medical practitioner, the visible beam can serve as a tracer beam, permitting the medical practitioner to observe where the laser beam may be incident on the tissue sample.

**[0071]** The laser beam delivery assembly may be non-invasive (e.g., applied externally to the body, such as in dermatology or ophthalmology) or minimally invasive (e.g., percutaneous or inserted into the body, such as to reach an organ or cardiology applications). In one embodiment, a non-invasive delivery arm may have light guided through a fiber in the flexible arm, and then the delivery head may have mirrors or lenses at the end to collimate or focus the light beam from the fiber onto the sample of interest. In a particular embodiment relating to dermatology, it may be desirable to have a spot size onto the tissue ranging in diameter from approximately 3mm to 1 cm or more. In another embodiment relating to ophthalmology, it may be desirable to have a focusing arrangement at the delivery head. For example, the delivery head may have a tip that can be placed on the surface of the eyeball, and the focusing arrangement may be adjusted to focus the light from the mid-infrared laser into the cornea in a controlled manner such that the focus of the radiation can be at a predetermined depth. As one non-limiting example, the focusing elements may focus the laser to a depth of less than about 450 microns in the corneal tissue. In another preferred embodiment, the fo-

cusing element may create a beam waist at a depth of about 300 to 400 microns below the anterior of the corneal surface.

**[0072]** In one embodiment where the laser beam delivery assembly is used for applying light to the skin, eyeballs or externally to other organs, it may be advantageous to also have a cooling mechanism at the delivery head. For example, the cooling can protect the top layer of the skin, eyeball or organ and can remove heat from the top layers as light penetrates into the sample. In the dermatology example, the cooling can be used to protect the epidermis and the top layer of the dermis. For instance, the mid-infrared light may be used to cause selective damage at a depth of 1 to 3mm, while the cooling protects the epidermis and top layer of the dermis. In one embodiment, the cooling can be achieved by using a cold window at the end of the delivery head. For example, the cold window can be a sapphire window. One advantage of sapphire material is that it can have a relatively high thermal conductivity and it can also be transparent in the mid-infrared wavelength range. Cooling can be achieved by flowing chilled water or other cooling fluid from a pumping system to the window at the end of the delivery head. As an example, the temperature at the head may be controlled by the flow rate or the temperature of the fluid bath at the pumping system. In yet another embodiment, a cryogenic spray system may be used to cool the tissue in the vicinity of the delivery head, and the timing of the sprays can be adjusted to achieve the desired cooling. In either case, there can be pre-cooling, simultaneous cooling, and/or post-cooling at the time of laser exposure to the tissue.

**[0073]** There may also be alternative designs for the laser beam delivery assembly for percutaneous or minimally invasive procedures, such as those used to reach an organ or artery in the body. The catheter or system for snaking into the body should be made relatively thin, and the flexible assembly should be capable of being manipulated by the medical professional external to the body to guide the catheter to the appropriate location. In one embodiment, there may be a radio opaque material at or near one end of the catheter, so the catheter can be guided using an x-ray or some other imaging system. The catheter may also comprise mirrors or lenses to collimate or focus the light either straight or at some desired angle. In some instances, it may also be desirable to have the catheter be rotatable over a range of angles. In another embodiment, the catheter may also have a camera or imaging system, so the medical professional can view on a monitor the image at the end of the catheter. In yet another embodiment, the catheter may also have a suction or removal system for removing debris or damaged tissue from in front of the catheter tip or surroundings. For example, it may be desirable to have a suction system to remove melted or damaged fat from around the catheter. This may be useful so the damaged adipose does not become self-limiting, in the sense that the fat in front of the laser beam can prevent the laser from further

penetrating into the tissue. Although particular details of laser beam delivery have been discussed, additional elements or combinations can be used consistent with this disclosure.

**[0074]** For either the non-invasive or minimally invasive laser beam delivery system, other modifications may also be made, such as using a fractionated laser beam. In one embodiment, a fractional beam may thermally alter approximate microscopic treatment columns in the tissue, while leaving intervening areas of the tissue between the columns substantially undamaged. In this example, since only a fraction of the tissue can be modified, untreated areas may be able to repopulate the treatment columns, thereby reducing recovery time and avoiding adverse events. In one example, the fractionated laser beam can lead to beneficial procedures in dermatology. In one particular embodiment of skin tightening or rejuvenation, in the approximate columns where the laser beam is exposed, the exposed tissue may be in tension due to shrinkage of collagen by the heat generated by the laser beam. This tension then may close the voids, tightening the skin and reducing the wrinkles. Thus, in some embodiments the fractional laser beam treatment can shorten the wound healing process by allowing the tissue between the areas of the laser exposed to help in the recovery.

**[0075]** The fractionated laser beam may be added to the laser delivery assembly or delivery head in a number of ways. In one embodiment, a screen-like spatial filter may be placed in the pathway of the beam to be delivered to the biological tissue. The screen-like spatial filter can have opaque regions to block the light and holes or transparent regions, through which the laser beam may pass to the tissue sample. The ratio of opaque to transparent regions may be varied, depending on the application of the laser. In another embodiment, a lenslet array can be used at or near the output interface where the light emerges. In yet another embodiment, at least a part of the delivery fiber from the mid-infrared laser system to the delivery head may be a bundle of fibers, which may comprise a plurality of fiber cores surrounded by cladding regions. The fiber cores can then correspond to the exposed regions, and the cladding areas can approximate the opaque or areas not to be exposed to the laser light. As an example, a bundle of fibers may be excited by at least a part of the laser system output, and then the fiber bundle can be fused together and perhaps pulled down to a desired diameter to expose to the tissue sample near the delivery head. In yet another embodiment, a photonic crystal fiber may be used to create the fractionated laser beam. In one non-limiting example, the photonic crystal fiber can be coupled to at least a part of the laser system output at one end, and the other end can be coupled to the delivery head. In a further example, the fractionated laser beam may be generated by a heavily multi-mode fiber, where the speckle pattern at the output may create the high intensity and low intensity spatial pattern at the output. When referring to "coupling" in this disclosure, it

is intended to cover both the cases of directly coupling and indirectly coupling (i.e., there can be additional intervening elements). Although several exemplary techniques are provided for creating a fractionated laser beam, other techniques that can be compatible with optical fibers are also intended to be included by this disclosure.

**[0076]** The discussion to this point in the disclosure has been more about the tissue properties, laser designs, laser output parameters, and delivery of the laser to a patient. In the following, applications of the laser to different medical fields and different tissue types will be described in more detail.

#### 15 *Collagen Shrinkage With Heating*

**[0077]** Collagen connective tissue is ubiquitous in the human body and demonstrates several unique characteristics, including strength and resilience in various tissue types. It can provide the cohesiveness and tenacity of the musculo-skeletal system, the structural integrity of the viscera, as well as the elasticity of the integument. Collagen fibers are composed of a triple helix of protein chains, with inter-chain bonds creating a crystalline structure for the collagen. When heated sufficiently, collagen can transform from the crystalline triple helical structure to an amorphous, random coil structure through the breakage of the hydrogen bonds linking the protein strands of the triple helix. This can create a thickening and shortening of the collagen fibers as the chains fold and assume a more stable configuration. Temperature elevation can result in contraction of the fiber to about two-thirds of their original lineal dimension (i.e., shrinkage by a third of the original dimension) without changing the structural integrity of the connective tissue. This collagen contraction can be used for a number of beneficial applications in vast areas including, but not limited to, ophthalmology and dermatology.

**[0078]** There is not necessarily a specific shrinkage temperature for collagen reaction. It is believed that the amount of collagen contraction could be related to a combination of the time and temperature. For example, for relatively long exposures of several seconds, the shrinkage temperature can be in the range of 60 to 70 degrees Celsius. It is believed that normal stabilized collagen fibers are stable up to a temperature of about 58 to 60 degrees Celsius. Also, normal tendon collagen can have a shrinkage temperature threshold which is about 2 to 4 degrees Celsius less than the corresponding threshold for skin collagen. Therefore, one aspect of this disclosure can be to raise the temperature of the collagen in the temperature range of approximately 60 to 70C to create thermal shrinkage but not to raise the temperature too much higher, which could result in thermal damage to the collagen. Since the normal body temperature is about 37C (98.6F), this means the laser energy absorbed could raise the temperature between approximately 10 to 33C, more preferably 23 to 33C, or in one preferred embodi-

ment between 23 to 28C.

*Application Of Collagen Contraction To Ophthalmology*

**[0079]** The cornea of the eye is a unique example of collagen connective tissue with the cornea stroma, which accounts for about 90% of the total thickness of the cornea, demonstrating a high transparency of cross-oriented sheets or lamellae of collagen (mostly type I collagen). To better understand this application, a review is first provided of the human eye structure. Figure 14 (left side) is a horizontal section of an eye 1400 having a roughly spherical structure with a transparent cornea 1401 at the forward central portion, the remainder of the sphere of the "eyeball" being white and opaque sclera 1402 (often called the whites of the eye) that is attached to and blends in with the cornea periphery. The eye's light-sensitive retina 1403 extends along the rear and part of the forward inner surface of the sclera, and it is connected to an optical nerve 1404 that extends to the brain. The eye 1400 is disposed within any eye socket or orbit typically behind an eyelid.

**[0080]** Positioned behind the cornea is a crystalline lens 1405 supported by zonular ligaments 1406, and the lens is capable of shape changes that enable the eye to focus on objects at various ranges. The eye's iris 1407 is positioned between the cornea and lens to divide the space forward of the lens into an anterior chamber 1408 and posterior chamber 1409 that are filled with aqueous humor. The space behind the lens is filled with a clear gel-like body 1410 called the vitreous humor.

**[0081]** The right side 1450 of Figure 14 is an enlargement of the corneal cross-section 1401 to show the various layers of the cornea. The outermost or anterior layer is the epithelium 1451 and its base membrane. The epithelium is typically about 50 microns thick and accounts for about ten percent of the total corneal thickness. The next layer is Bowman's membrane 1452, which is non-regenerative and which is about 10-13 microns thick in the human eye. The main body of the cornea is the stroma 1453, which accounts for about 90 percent of the total corneal thickness. The stroma is composed of clear sheets of collagenous material, and most of this is type I collagen. The stroma is backed by Descemet's membrane 1454, which is about 5-10 microns in thickness. Finally, the innermost or posterior layer of the cornea is the endothelium 1455, which is a single layer of non-reproducing flattened cells of about 4-5 microns thickness.

**[0082]** Although the geometry of the cornea is complex, it has surfaces that are approximately concentric and spherical, the radius of curvature of the outer or anterior surface typically being about 8 millimeters. The corneal diameter is about 11mm, and the total thickness at the corneal center is about 0.55mm (550 microns). Thus, the thickness of the stroma is in the range of 450 to 500 microns.

**[0083]** About three-fourths of the eye's refractive power

can be determined by corneal curvature, and shape modification of this element of the eye's optical system thus provides a useful tool for correction of refractive errors. The change in shape can be provided by heating the collagen-rich stroma. However, a problem with heating the eye can arise in the possibility of damage to the epithelium and Bowman's membrane on the anterior side of the cornea, as well as Descemet's membrane and the endothelium on the corneal posterior. Therefore, it may be desirable to minimize the heating effects in these sensitive membranes while still obtaining the desired 60C to 70C temperature range in the stroma. Thus, it can be advantageous to have a laser wavelength that may be selectively absorbed in the collagen-rich stroma, such as mid-infrared wavelengths in the vicinity of 1720nm. Other wavelengths can be used consistent with this disclosure as well, such as 1210nm or around 2300nm as non-limiting examples.

**[0084]** In one embodiment, an optional supplement to the mid-infrared laser exposure is to borrow on techniques similar to that used in Laser Assisted in-Situ Keratomileusis (LASIK) surgery. For example, in LASIK a corneal flap is created in some examples using a mechanical blade or a femto-second laser. In exemplary instances, the flap thickness may range between approximately 150 and 200 microns. Thus, the residual stroma left after the flap is of order of or greater than 250 microns. Then, in many cases an excimer laser is used to ablate at least a portion of the stroma to achieve the desired reshaping of the cornea.

**[0085]** Borrowing from these LASIK techniques, in one embodiment the corneal flap may be created, thus sparing the epithelium 1451 and vulnerable Bowman's membrane 1452 from the laser heating. With the flap lifted or put aside, the remaining corneal stroma 1453 may then be exposed to the mid-infrared radiation to achieve the desired collagen shrinkage to reshape the cornea. The selectivity can still be advantageous, so that the heating can be localized and damage to the Descemet's membrane 1454 and endothelium 1455 may be avoided.

**[0086]** Because of the selectivity in absorbing in the collagen-rich areas, one advantage of using mid-infrared wavelengths for light exposure could be that a flap-less LASIK type procedure could be performed, which would be relatively non-invasive. For example, most of the complications of LASIK surgery currently are associated with the cutting of the flap and healing of the flap after surgery. Also, infections of the eye can result from the cutting of the corneal flap. By exposing the corneal tissue and having absorption of the light energy directly in the cornea without cutting off the corneal flap, many of the complications of LASIK could be minimized. Although the amount of refractive index correction in the cornea may be more limited using the flap-less LASIK procedure, the non-invasive nature of the procedure should be attractive in many instances. Also, the flap-less LASIK procedure could benefit from top layer cooling using a cold window, as further described below.

**[0087]** Beyond using the selectivity of the mid-infrared wavelengths for ophthalmology procedures, it could also be beneficial to use surface cooling or a cold window to cool the surface of the eye before, during, and after exposing the laser light. This could still be a non-invasive procedure, since the cold window or surface cooling could be applied directly to the surface of the eye. As laser light is incident on the eye, the light energy may be highest near the outer surface, and then the light energy will decrease as the light penetrates further into the eye because of absorption and scattering. Hence, it is very likely that the outer layers of the eye are more vulnerable to heating damage. By surface cooling or placing a cold window next to the eye, the heat can be removed from the top layers, thereby lowering the possibility of thermal damage in the unwanted areas. This can enhance the collagen heating in the corneal stroma, while avoiding damage particularly in the epithelium and Bowman's membrane, as an example. Although surface cooling is described, many other embodiments to cool the top layers or conduct heat away could be used consistent with the disclosure. For example, a cryogenic spray could be used, where cold gases or emission is sprayed onto the surface of the eye.

**[0088]** Although several examples are provided for alternative techniques for mid-infrared laser usage in an ophthalmology procedure, there are numerous other techniques in ophthalmology that can benefit from using a mid-infrared laser for collagen shrinkage or localized, selective heating or damage. Another benefit of using mid-infrared laser light in ophthalmology applications, particularly at wavelengths near 1720nm, can be that the wavelength lies in the eye safe wavelength range. For example, since the aqueous humor and vitreous humor do not transmit effectively wavelengths beyond approximately 1400nm, using the mid-infrared light near 1720nm can avoid or minimize risk of damage to the retina from residual radiation from the corneal reshaping procedure.

**[0089]** Also, other modifications to the laser exposure can be made and are included as parts of this disclosure. For example, the collagen shrinkage using mid-infrared light can be preceded by application of a reagent to the collagen tissue for reduction of the shrinkage threshold temperature. Examples of preferred reagents include hyaluronidase and lysozyme. It has been reported that with application of such reagents that the collagen shrinkage temperature can be lowered by 10C to 12C. This has advantages because it means less laser energy can be deposited in the stroma. Thus, there can be less chance of damage to the surrounding tissue. Moreover, the gap between collagen shrinkage energy and collagen damage energy can be enlarged. Although one example is shown of modifying the collagen shrinkage procedure, any number of improvements in terms of spatial focusing, additional chemical applications, or laser alternations can be made consistent with this disclosure and are intended to be covered by this disclosure.

**[0090]** In yet another embodiment, the mid-infrared light treatment may be accompanied by techniques to prevent or minimize regression of collagen shrinkage. If the collagen of the stroma or other sections of the eye are damaged sufficiently, then the body may react using, for example, its natural wound healing processes. Consequently, loss of the collagen shrinkage effect as a function of time, otherwise known as regression of the desired effect, can result from the wound repair process. Several techniques may be used to try to minimize the regression. In one example, by controlling the exposure time and power level or fluence of the mid-infrared appropriately, collagen shrinkage might be obtained without the damage that leads to the wound repair mechanisms. In this instance it may be advantageous that the light can be absorbed selectively in the collagen-rich stroma and that by being near the peak of the local absorption, the heating can be accomplished more efficiently. In addition, the cooling of the outer layers of the eye may also be advantageous, since damage in the outer layers may be avoided, thereby not leading to the body initiating a wound healing process. In a further embodiment, preheating or pre-cooling may lead to a shock response in the eye, which then increases the tolerance of the eye to laser treatment, thereby increasing the threshold for the wound healing processes. In yet another embodiment, chemicals may be applied to the eye that may counter-act or inhibit the wound healing mechanisms in the eye. The goals of such procedures may be to increase the time or permanence of the collagen shrinkage effect.

#### *Treatment Examples In Ophthalmology*

**[0091]** Keratoconus can be one example of applying the above concepts to the field of ophthalmology. Keratoconus is a degenerative disorder of the eye where structural changes within the cornea cause it thin and change to a more conical shape than its normal gradual curve. It is typically diagnosed in the patient's adolescent years and attains its most severe state in the twenties and thirties. Keratoconus is the most common dystrophy of the cornea, affecting around one person in a thousand. Also, between 10% and 25% of cases of Keratoconus will progress to a point where vision correction is no longer possible, thinning of the cornea becomes excessive, or scarring as a result of contact lens wear causes problems of its own.

**[0092]** Alternative laser-based procedures are needed because LASIK can be incompatible with Keratoconus and other corneal thinning conditions as removal of corneal stromal tissue will further damage an already thin and weak cornea. Contact lenses are the primary treatment for most patients with Keratoconus. Severe cases may require corneal transplantation. This is a surgical procedure that replaces the Keratoconus cornea with healthy donor tissue. In this process much of the central cornea of the Keratoconus patient is removed and is replaced with the cornea of a recently deceased person.

**[0093]** Some newer technologies may use high frequency radio energy, where the energy shrinks the edges of the cornea, which in turn pulls the central area back to a more normal shape. The procedure is known as Conductive Keratoplasty, which uses radiofrequency to strategically heat and shrink tiny parts of the collagen in the cornea. However, the radio frequency energy cannot be highly focused, and the radio frequency heating may heat anything with water content, which may not be selective to the stroma. Also, this is not a non-invasive procedure, since needles or antennas are inserted into the eye to localize the RF energy in certain regions.

**[0094]** An advantageous treatment for Keratoconus that may avoid the need for corneal transplantation could be to use the collagen shrinkage techniques described above. For example, the mid-infrared light can be focused using an appropriate lens system, and the beam waist could be tailored to lie around the middle of the stroma, in one embodiment in the range of 300 to 400 microns depth below the anterior corneal surface. Also, the mid-infrared light could be focused around the edges of the cornea in the stroma, collagen-rich areas, so that the collagen shrinkage may shrink the edges of the cornea and pull the cornea back to a more normal shape. In an alternate embodiment, the mid-infrared light could be focused closer to the center of the corneal stroma, thereby, for example, shrinking the center peak in the cornea. In one example, the stroma could be heated to a temperature in the range of 60C to 70C, while minimizing heating in the surrounding sensitive membranes, particularly in the endothelium.

**[0095]** The stroma can be selectively heated using a combination of two effects. First, selecting a wavelength corresponding to a collagen peak with less water absorption can cause more heating in the collagen-rich stroma. Second, by focusing the mid-infrared laser beam toward the center thickness of the stroma, the light intensity (power per unit area) can be higher in the stroma than in the surrounding membranes. In one preferred embodiment, the laser beam can have a beam waist that is approximately centered on the stroma central thickness, and the focal spot size can be adjusted so that the confocal parameter or Rayleigh range (i.e., the distance over which the beam diffracts to twice its smallest beam waist) is adjusted to be approximately less than the thickness of the corneal stroma, which is of order of 450 microns. Earlier reports claim that the collagen shrinkage appears to be permanent, with the potential of little or no lasting opacity of the treated site resulting from the mid-infrared light exposure. If the collagen shrinkage is not permanent, then the non-invasive procedure can be repeated after some length of time. For example, a Keratoconus patient may return for mid-infrared laser treatment every six months to touch-up any reshaping of the corneal layer. In yet another embodiment, some of the techniques described earlier for preventing regression can be used in conjunction with the collagen shrinkage procedure.

**[0096]** Although Keratoconus is described as one non-

limiting example, there are many other ophthalmology procedures where the collagen shrinkage with laser exposure can be advantageously used. For example, in one embodiment the collagen shrinkage with heating could be useful for promoting collagen cross-linking. In the collagen cross-linking, new bonds can form across adjacent collagen strands in the stromal layer of the cornea, which recovers and preserves some of the cornea's mechanical strength. In one embodiment, the cross-linking could be used to attach cornea transplants or to join segments of cornea that are separated for any reason.

**[0097]** In yet another embodiment, different refractive index changes in the cornea or "refractive power correction" can be corrected by proper spatial placement of the laser beam exposed regions. For example, to correct for hyperopia (far-sightedness or long-sightedness), it may be advantageous to have the laser beam focused at locations on the side or periphery of the cornea. For example, in hyperopia it may be desirable to increase the steepness of the cornea to increase the refractive lens power. On the other hand, to correct for myopia (near-sightedness or short-sightedness) it may be advantages to have the laser beam focused closer to the center of the cornea. For instance, for myopia treatment it may be desirable to flatten the center of the cornea to decrease the refractive power of the cornea, and in one embodiment a diameter of approximately 6mm may be used around the center of the cornea. Since myopia is among the most common eye ailments, treating myopia using mid-infrared light in an approximately non-invasive procedure may have a large impact. However, since the center of the cornea is more likely to be exposed to mid-infrared radiation in treating myopia, it may be important to control the laser exposure time, power level or fluence, so that damage and opacity can be avoided in the cornea and surrounding areas. As the collagen shrinkage is accomplished using the mid-infrared light, some of the issues to monitor include the clarity of the corneal layer after laser treatment and any damage to the outer layers, such as the epithelium or Bowman's membrane. Surface cooling or application of a cold window, for example, could also help in avoiding damage to the outer layers.

**[0098]** Although LASIK is a widely used procedure, it is contraindicated in any of the corneal thinning conditions, or conditions where the cornea is weakened. Consequently, one general area where collagen shrinkage with mid-infrared light exposure can be advantageously used is in procedures involving a thinned or weakened corneal layer. Also, since the mid-infrared light exposure can be non-invasive (e.g., it does not necessarily require the moving back of a corneal flap, such as in LASIK), the collagen shrinkage procedures can be performed on patients to trim or slightly modify the corneal shape. The non-invasive procedure may also be accompanied by surface cooling or a cold window to avoid damage to the eye. Also, some of the techniques for avoiding regression may also advantageously be used. One advantage of the collagen shrinkage technique may be the reversibility

of the change, so long as the collagen shrinkage is achieved without damage. This may be valuable if, for example, proper refractive power correction is not achieved during the procedure.

**[0099]** It will be appreciated that there are many other corneal procedures that can benefit from this non-invasive technique. For example, astigmatism may be corrected by having laser light resonant with the collagen absorption. As one other non-limiting example, the collagen shrinkage may be beneficial in treating presbyopia. Presbyopia is often called "old eye" and is experienced in many people starting around the age of 40-50 years. With presbyopia, it often becomes harder to focus on small objects at close distance. As one ages, the lens 1405 can become less malleable or the capsule less elastic; consequently, the lens 1405 may not assume a greater curvature in spite of the reduced tension of the zonules 1411 upon the lens.

**[0100]** The ciliary muscle or body 1412 is a smooth muscle in the eye that controls the eye's accommodation for viewing objects at varying distances. The circular ciliary muscle fibers 1412 affect zonular fibers 1411 in the eye (fibers that suspend the lens in position during accommodation), thereby enabling changes in lens shape for light focusing. For example, when the ciliary muscle 1412 contracts, it pulls itself forward and can move the frontal region toward the axis of the eye. This can release the tension of on the lens by the zonular fibers 1411, thus causing the lens to become more spherical and able to adapt to shorter range focus. On the other hand, relaxation of the ciliary muscle 1412 can cause the zonular fibers 1411 to become taut, flattening the lens, and thus increasing the long range focus.

**[0101]** In one particular embodiment, an at least partial treatment for presbyopia can result by exposing at least parts of the ciliary muscle or body 1412 and/or the zonular fibers 1411 to mid-infrared light. By utilizing the shrinkage of collagen connective tissue at the site of the ciliary muscle 1411 and zonular fibers 1412, the ability to control the curvature of the lens 1405 or to accommodate an enlarged lens 1405 could be improved.

**[0102]** For instance, by shortening or shrinking the tendinous portions of the ciliary musculature 1411 to increase its mechanical advantage, it may be possible to overcome the physiologic laxity in the accommodative function brought about by presbyopia. Moreover, the collagen shrinkage could also assist in more accommodating motion of the lens 1405 by tightening the trabecular meshwork of the aqueous filtration mechanisms in the region near the ciliary 1411. Note, however, that these regions of the eye lie below the sclera tissue 1402. One potential advantage of using mid-infrared light that may be selectively absorbed in collagen can be that the light can transmit through the sclera 1402 to the regions near or surrounding the collagen tissue in the ciliary muscle 1411 and zonular fibers 1412. Consequently, the procedure to treat presbyopia could be substantially non-invasive. The mid-infrared light treatment can be combined

with any number of the techniques described in this specification. For example, it may be advantageous to also use surface cooling over the sclera 1402 to avoid thermal damage in this tissue layer. Also, chemicals, drugs or other techniques to avoid or minimize regression may be used advantageously with the mid-infrared light treatment.

### *Selective Damage In Dermatology*

**[0103]** Another example of the application of mid-infrared lasers for selective damage to the human body is in dermatology. Before describing this application in more detail, a review is first provided of the skin, which is the largest organ in the body and comprises about 15 percent of the body weight. The skin 1500 is composed on three main layers: epidermis 1501, dermis 1502, and subcutaneous tissue 1503 (FIGURE 15). The epidermis 1501 is the topmost layer of the skin, and it comprises three types of cells: keratinocytes, melanocytes and Langerhans cells. Keratinocytes, the cells that make the protein keratin, are the predominant type of cells in the epidermis. The total thickness of the epidermis is in the range of 0.1 to 1mm, depending on the location on the body. At the lowermost portion of the epidermis are immature, rapidly dividing keratinocytes. As they mature, keratinocytes lose water, flatten out, and move upwards. At the end of their life cycle, they reach the uppermost layer of the epidermis call the stratum corneum. The stratum corneum is made up mostly of dead keratinocytes, hardened proteins (keratin) and lipids, thereby forming a protective crust. Dead cells from the stratum corneum continuously fall off and are replaced by new ones coming from below. In fact, the skin completely renews itself every three to five weeks.

**[0104]** Another group of cells in the epidermis 1501 are the melanocytes, which produce melanin, the pigment responsible for skin tone and color. Finally, Langerhans cells are part of the immune system of the epidermis, and they prevent unwanted foreign substances from penetrating the skin.

**[0105]** The dermis 1502 is the middle layer of the skin located between the epidermis and subcutaneous tissue. It is the thickest of the skin layers and comprises a tight, sturdy mesh of collagen 1507 and elastin fibers 1508. Both collagen 1507 (mostly Type I) and elastin 1508 play a big role in the skin function: collagen is responsible for the structural support and elastin for the resilience of the skin. The fibroblasts in the dermis synthesize collagen, elastin and other structural molecules.

**[0106]** The dermis also contains capillaries and lymph nodes. The former help to oxygenate and nourish the skin, while the latter help to protect the skin from invading microorganisms. In addition, the dermis contains sebaceous glands 1505, sweat glands 1506, hair follicles 1504, as well as a relatively small number of nerve and muscle cells. Sebaceous glands 1505 are lipid-rich glands, which are located around hair follicles 1504. The

sebaceous glands 1505 produce sebum, which is an oily protective substance that lubricates and waterproofs the skin and hair. Overproduction of sebum can lead to skin ailments, such as oily skin or acne.

**[0107]** Subcutaneous tissue 1503 is the innermost layer of the skin located under the dermis 1502 and comprising mostly fat or adipose. The predominant type of cells in the subcutaneous tissue 1503 is adipocytes or fat cells. Subcutaneous fat 1503 acts as a shock absorber and heat insulator, protecting underlying tissues from cold and mechanical trauma.

**[0108]** The dermis 1502, 1602 is the layer of the skin 1600 responsible for the skin's structural integrity, elasticity, and resilience. Wrinkles 1605 arise and develop in the dermis (FIGURE 16). Wrinkles 1605 are mainly formed by the distortion of the dermis 1602 due to loss of elasticity induced by decrease of collagen and elastin fibers. Therefore, an anti-wrinkle treatment can be effective in one embodiment only if the treatment can reach as deep as the dermis. For example, light treatments that use a wavelength of light that do not penetrate down to the dermis will probably not be efficacious in treating wrinkles 1605. Also, typical collagen and elastin topical creams are not generally effective because collagen and elastin molecules are too large to penetrate the epidermis 1601.

#### *Non-Ablative Skin Rejuvenation, Tightening, Wrinkle Removal*

**[0109]** Non-ablative, non-invasive skin tightening, skin rejuvenation and wrinkle removal could be advantageously accomplished using mid-infrared light. The dermis 1501, 1602 is composed mainly of collagen 1507, elastin 1508 and sebum. Both collagen 1507 and elastin 1508 can be responsible for renewing skin cells and maintaining a youthful appearance of the skin. Skin tightening has been achieved in earlier systems, for example, using either radio frequency or flash lamp systems. In the radio frequency systems, the RF is absorbed in the subcutaneous fat layer 1503, and the heat generated from this transfers to the dermis 1502 and is used for stimulating collagen growth. On the other hand, flash lamp systems with light covering approximately 1100 to 1800nm have been used for skin rejuvenation, but these systems try to trigger new collagen growth by using collagen contraction through heating of the surrounding water in the dermis 1502 and then transfer of this heat to the collagen. However, both of these systems can be inefficient and may deliver too much energy to the skin, leading to potential unnecessary harm to the epidermis 1501 or pain to the patients undergoing the treatment.

**[0110]** In one embodiment, a more efficient use of the laser light can be achieved by using wavelengths in the vicinity of local peaks in absorption of the constituents of interest in the dermis 1502, 1602. For example, as FIGURE 7 illustrates, collagen 703 elastin 704 and adipose 702 all can have a local peak absorption near 1720nm

706. This window also can correspond to a local minimum in water absorption 701, and the scattering can also be low at the longer wavelengths. Another exemplary wavelength window can be in the neighborhood of 1210nm 705: however, the peaks may not be as precisely lined up, the absorption of collagen 703, elastin 704 and adipose 702 appears to be considerably weaker, the water 701 can have a local peak in absorption in this window, and the scattering through the tissue can be higher at this shorter wavelength.

**[0111]** In the embodiment using mid-infrared light near 1720nm 706, the light can be preferentially absorbed in the collagen 703, elastin 704, and adipose or sebum/adipose 702, leading to the desired heat generation in the dermis. The heat generated can then lead to collagen contraction as well as rejuvenation of the collagen 1507 and elastin 1508 tissue. The heated collagen can transform from the crystalline triple helical structure to an amorphous, random-coil structure through the breakage of the hydrogen bonds linking the strands of the triple helix. Hence, non-ablative skin rejuvenation, skin tightening and/or wrinkle removal can be achieved with potential efficient use of the optical energy.

**[0112]** Another advantageous aspect of using mid-infrared light for skin treatment can be that a deeper penetration into the skin can be achieved. The epidermis 1501 may be of order 0.1mm thick, while the dermis 1502, 1602 can be about 4 mm in thickness. For treatment of the dermis 1502, 1602, it may be desirable for the heat penetration depth to be about 1 to 2mm, perhaps with some heating down as far as 4 or 5mm. In one particular embodiment, penetration of laser light in the depth range of approximately 0.5mm to 1.5mm may be desirable. In another preferred embodiment, the heating can reach down to the middle or bottom of the dermis layer 1502, 1602. Based on the water absorption 402 and scattering 401 through skin tissue (FIGURE 4), the penetration depth into the skin 1500 can be estimated. For example, as shown in FIGURE 5, the total absorption and scattering coefficient 501 can be approximately  $6.8 \text{ cm}^{-1}$  at 1210nm, which corresponds to an absorption length (inverse of the coefficient) of about 1.47mm. Thus, the light penetration at 1210nm can be of order one to three absorption lengths, or approximately 1.5mm to 4.5 mm in depth. On the other hand, the total absorption and scattering coefficient 501 can be approximately  $8.25 \text{ cm}^{-1}$  at 1720nm, which corresponds to an absorption length of about 1.2mm. Thus, the light penetration at 1720nm can be approximately 1.2mm to 3.6mm, which should be comfortably within the mid-range of the dermal layer 1502, 1602. As an example, one advantage of heating to a depth of 1 to 2mm can be that the dermal collagen fibers 1507 can be targeted while allowing a cooling mechanism to protect the epidermis 1501.

**[0113]** The curves in FIGURE 7 can lead to preferred embodiments for selective damage using mid-infrared lasers in the wavelength window near 1210nm 705 or 1720nm 706. Of these two window options, in some in-

stances it may be advantageous to select the longer wavelength window near 1720nm 706. For example, one reason for selecting this longer wavelength window may be to operate in the so-called "eye-safe" wavelength range, which can correspond to wavelengths longer than approximately 1400nm. A second advantage of the longer wavelength window near 1720nm 706 for dermatology applications can be that the peaks for the major constituents of dermis - namely, collagen, adipose and elastin -- all approximately line up near 1720nm 706. Therefore, the heat generation can be synergistic from optical absorption in all these constituents. Finally, for dermatology the efficiency of the optical energy delivery can be better at 1720nm 706 than at 1210nm 705. For example, the efficiency can be higher when the loss or absorption length (inverse of the absorption coefficient) is approximately matched for the propagation through skin tissue from water absorption and scattering 701 and, for example, the absorption length in adipose tissue 702. At 1720nm 706, for instance, the absorption length from water absorption and scattering can be 1.2mm (8.25 cm<sup>-1</sup> absorption coefficient), while the absorption length for adipose can be approximately 1.12mm (8.5 cm<sup>-1</sup>). On the other hand, at 1210nm 705, the absorption length from water absorption and scattering can be 1.47mm (6.8 cm<sup>-1</sup>), while the absorption length for adipose can be approximately 5mm (2 cm<sup>-1</sup>). For light excitation of adipose, 1720nm 706 can be more efficient than at 1210nm 705. At 1210nm the light can be lost more rapidly due to water absorption and scattering 701 in the tissue, and because of the weaker absorption in adipose more light energy will probably be required. To achieve the same results, a higher laser power exposure will probably be required at 1210nm 705, which could also mean that the epidermis 1501 and upper dermis layers 1502 are more susceptible to damage or scarring.

#### *Other Advantageous Dermatology Applications*

**[0114]** Yet another embodiment of a procedure that could benefit from using a mid-infrared selective laser is stretch mark or striae removal. Stretch marks, also called striae, are a common problem affecting a majority of women who have had children. For example, during pregnancy the skin of the abdomen stretches to many times its normal size as the baby grows. After the baby is delivered, the skin's elasticity in the dermis contracts to bring the abdomen skin back to its normal shape. During skin stretching, if the dermis expands too much or too fast, the dermis can break, split or rupture. These breaks in the dermis of the skin cause a wide depressed scar, which is called a stretch mark or striae.

**[0115]** Also, in recent years, the use of steroids has caused stretch marks in many young men who have worked very hard at body building and fitness. The use of steroid medications also causes striae even without tension or pulling on the skin. The mechanism of the striae caused by steroids can be a direct damage or dissolv-

ing of collagen in the dermis by the steroid medication. In addition, rapid growth spurts during adolescence or even in adults who are weight lifting and have rapid muscle expansion, can also cause rupture of the dermis and striae.

**[0116]** In one embodiment, repairing stretch marks and striae can require building new collagen 1507 in the dermis 1502, 1602 of the skin to replace the lost collagen and tightening of the skin to bring the stretched skin back together. This may be accomplished by heating using a mid-infrared laser system. For example, when the collagen is heated to a temperature in the range of 60-70C, the collagen can shrink and tighten, and the collagen can be stimulated to remodel and grow new collagen. It can also be advantageous to have a treatment where the laser heating penetrates sufficiently deep into the dermis 1502, 1602, for example in the range of 1 to 2mm. The dermis layers 1502, 1602 are where the collagen regeneration and elasticity of the skin can be most effective to recover from the stretch marks or striae.

**[0117]** Another aspect of this disclosure is that the selective absorption in collagen, elastin and adipose can be advantageously used for laser skin resurfacing to treat various kinds of skin flaws, such as sunburns, wrinkles, acne and acne scar removal. Such skin flaws are often treated using dermabrasion, which entails removing the topmost layer of the skin via a sanding procedure. However, this procedure is quite painful, often requiring the use of local anesthesia while applying to a patient. After such a procedure the skin can be raw and painfully tender, and new skin could take months to grow back. An alternative procedure may be to use chemical peels, which can use chemicals that cause the skin to blister and finally peel off.

**[0118]** A non-ablative laser procedure could be less painful and more efficacious for patients with skin flaws. A mid-infrared, non-ablative, laser procedure could work beneath the skin 1500, 1600 surface, stimulating collagen production and tightening the overall tissue. Another advantage of a laser-based technique can be that the laser beam can be targeted or localized to the region of interest, for example on the face or body of the patient. Yet another advantage of a selective laser damage technique can be that the patient can have a faster recovery time and less redness of the treated region, since the selective laser can lead to less damage to vascular fibroblast.

**[0119]** In one non-limiting example, the selective laser procedure can be used with patients afflicted with acne and the resulting acne scar tissue. The root cause of acne can be excess sebum production in the lipid-rich sebaceous glands 1505, which lie near the side or bottom of a hair follicle 1504. The sebaceous glands 1505 that cause acne typically lie in the region about 0.25 to 1.5mm below the skin surface. Incidentally, the excess sebum production can also lead to other skin ailments, such as oily skin. Unfortunately, acne can leave behind unsightly and even disfiguring scars. Patients afflicted with acne

and the resulting scars may benefit from a mid-infrared skin treatment that can selectively target and comprise light absorbed in collagen, elastin and adipose. In one embodiment, mid-infrared light near 1720nm can be advantageously used, since the penetration depth can be well matched to the depths of the sebaceous glands 1505. In one non-limiting example, the mid-infrared light can be selectively absorbed in the sebaceous glands 1505, thereby halting the excess sebum production. In addition, the selective absorption in the collagen 1507 and elastin 1508 of the dermis can be used to help repair the skin flaws. For example, with the collagen shrinkage and stimulating collagen production, the acne scar tissue can be replaced with new skin. Therefore, the selective absorption of the mid-infrared light in the dermis has the potential to treat the root cause of acne as well as repair the acne scar tissue.

**[0120]** Although a few dermatology applications have been described, there are many other applications of the mid-infrared light in dermatology that are intended to be covered by this disclosure. Therefore, the listed procedures are provided by way of example, but the disclosure could also cover many other dermatology applications. For example, yet another dermal application that can benefit from mid-infrared light resonant with the collagen, elastin and adipose is wound healing or dermal remodeling. For example, stimulation of collagen bio-synthesis is often desirable in the early stages of wound healing. The heating through selective absorption in the collagen, elastin and adipose near the wound region can lead to collagen contraction and skin rejuvenation.

#### *Combining Mid-Infrared Light With Other Dermal Techniques*

**[0121]** In describing the dermatology applications, the above description has just described using the mid-infrared laser light (exemplary near 1720nm, possibly 1210nm) directly to the skin to have selective absorption in the dermis in the collagen, elastin and adipose. However, this disclosure is intended to cover combining the mid-infrared laser treatment with any number of temporal, spatial or procedural techniques that are known to be used in dermatology. In one embodiment, it is contemplated that the laser treatment can be done at different time periods. For example, it can be likely that the non-invasive tissue mechanisms relate both to the immediate as well as delayed effects on collagen. Although initial research studies presumed the collagen shrinkage to be irreversible, newer evidence suggests that the melting temperature of collagen can be actually lower than 37C, and that there may be a tendency for reversibility. Collagen melting occurs at body temperature but the time intervals are relatively long. Consequently, the collagen shrinkage effect may be reversed after several weeks or months. Therefore, it may be necessary to repeat the collagen shrinkage every several weeks or every several months, depending in part on the severity of the skin

changes.

**[0122]** In yet another embodiment of combining different dermatological procedures, it is likely that the mid-infrared light exposure may have to be combined with protecting the epidermis 1501 and top layer of the dermis 1502 using external cooling, such as a cold window or cryospray. In most non-invasive, non-ablative laser dermatology procedures, external cooling is used to protect the epidermis 1501 and top layer of the dermis 1502. There can be pre-cooling, cooling in parallel with the laser exposure, and post-cooling. Therefore, the cooling of the skin top layer is contemplated as part of this disclosure of applying mid-infrared light to the skin to selectively absorb. One benefit of selective absorption in collagen, elastin and adipose can be that the procedure may result in less pain to the patient. For example, techniques that rely on absorption in water often require more energy and can also be more painful, since water is throughout the skin. With the selective absorption at the mid-infrared wavelengths, less collateral heating can occur, which can reduce the pain level experienced by the patient. Nonetheless, it still may be desirable to use a local anesthetic to lower the pain felt by a patient when exposing the laser light.

**[0123]** Another embodiment of using the mid-infrared laser treatment may also be to combine the selective absorption with a fractionated laser beam. The fractionated laser beam comprises an array of microscopic beams. With this array pattern for the beam, the laser can be adapted to make tiny wounds in the dermis layer to trigger the nature healing abilities of the body. Although several laser procedures may be required, it is believed that making the micro-laser damage spots may enhance the recovery of the skin because the undamaged skin surrounding the laser spots will aid in the recovery. It is contemplated that using a fractionated laser beam with the mid-infrared light near wavelengths such as 1210nm or 1720nm can be within the scope of this disclosure.

**[0124]** Yet another embodiment of using mid-infrared laser can be to combine the laser exposure with topical creams or other substances applied to the skin surface. For example, in some procedures it might be desirable to apply keratin or a related compound to the skin surface, which can also aid in the collagen or elastin rejuvenation. In another example, polypeptide growth factors may be applied to the skin, as they are believed to play a role in skin healing. In yet another example, local anesthetics may be applied to the skin or a cool pack to relieve pain associated with the light exposure.

**[0125]** In yet another embodiment, the time exposure of the mid-infrared laser may be varied to obtain different effects. For example, in some instances the pain felt by the patient can be reduced by using lower fluence (one example being in the range of less than 30 J/cm<sup>2</sup>) but for longer periods of time, for example of order 10 seconds. If the time of exposure to the laser is very short compared to the time required for heat to diffuse out of the area exposed, namely the thermal relaxation time, then the

temperature rise at any depth in the exposed tissue can probably be proportional to the energy absorbed at that depth. On the other hand, if the pulse width is comparable or longer to the thermal relaxation time of the exposed tissue, then the profile of temperature rise may not be as steep. Conduction of thermal energy can occur at a rate proportional to the temperature gradient in the exposed tissue. Consequently, lengthening the exposure time may reduce the maximum temperature rise in exposed tissue. Different temporal patterns for the mid-infrared light are intended to be covered in this disclosure.

**[0126]** Although several embodiments of combining the mid-infrared laser exposure with other dermatology techniques are described, other combinations are also intended to be covered by this disclosure. Also, combinations of these techniques can also be used consistent with this disclosure.

#### *Adipose Tissue And Type 2 Diabetes*

**[0127]** With the growing epidemic of obesity in much of the industrialized countries, a growing number of human ailments are associated with adipose tissue (i.e., fatty tissue) building up excessively both inside and outside organs, arteries, and other parts of the body. One alarming statistic is that the prevalence of obesity in children has increased fairly dramatically over the last 20 to 30 years. Moreover, the prevalence of type 2 diabetes has also increased rapidly over the last 20 years. For example, the incidence of type 2 diabetes in adolescents has been estimated to increase ten-fold from 1982 to 1994 in the greater Cincinnati area. In addition, a significant number of obese youth have abnormally severe insulin resistance with an attendant increased risk of developing type 2 diabetes mellitus. In fact, there is a growing recognition that visceral or intra-peritoneal fat can be strongly associated with insulin resistance and other factors. In one embodiment, the mid-infrared light could be used to melt or damage the visceral or intra-peritoneal fat, thereby potentially reducing the risks associated with and incidence of type 2 diabetes in children, adolescents and adults. The mid-infrared light could also be used to render the adipose tissue inactive, in the sense that cytokines are no longer generated by at least some of the adipose tissue.

**[0128]** In humans, adipose tissue is located beneath the skin (subcutaneous fat), around internal organs (visceral fat), and in the bone marrow (yellow bone marrow). Adipose tissue is found in specific locations, which are referred to as 'adipose depots.' Adipose tissue contains several cell types, with the highest percentage of cells being adipocytes, which contain fat droplets. In the integumentary system, which includes the skin, adipose accumulates in the deepest level, the subcutaneous layer, providing insulation from heat and cold. Around organs, it provides protective padding.

**[0129]** Visceral fat or abdominal fat, which is also known as organ fat or intra-abdominal fat, can be located

inside the abdominal cavity, packed in between internal organs and torso. The visceral fat is composed of several adipose depots including mesenteric, perigonadal, epididymal white adipose tissue and perirenal depots. An excess of visceral fat is known as central obesity, or "belly fat", in which the abdomen protrudes excessively. There is a strong correlation between central obesity and cardiovascular disease. For example, adipose tissue secrete a type of cytokines (cell-to-cell signaling proteins) called adipokines or adipocytokines, which play a role in obesity-associated complications and cardiovascular diseases.

**[0130]** Central obesity is associated with a statistically higher risk of heart disease, hypertension, insulin resistance and type 2 diabetes mellitus. It is speculated that central obesity predisposes individuals to insulin resistance, and it may also be that the adipokines secreted by abdominal fat may impair glucose tolerance. Insulin resistance is a major feature of type 2 diabetes, and central obesity is correlated with both insulin resistance and type 2 diabetes. For example, increased obesity raises serum resistin levels, which in turn correlates with insulin resistance. Studies have also confirmed a correlation between resistin levels and type 2 diabetes.

**[0131]** In one embodiment, a mid-infrared fiber laser could be used to remove or damage at least some amount of visceral or abdominal fat, thereby reducing the probability of type 2 diabetes and insulin resistance. The removal or damage of the adipose can also reduce the cytokines and/or serum resistin secretion or generation, which can also potentially reduce some of the type 2 diabetes and cardiovascular complications. The selectivity of using mid-infrared wavelengths can be valuable, because the desire is to remove or damage the adipose without damaging the organs that are surrounded by the adipose or surrounding blood vessels. For example, it has been contemplated to use a liposuction type technique for removing visceral fat. In such a procedure, however, extreme care would be required to avoid damaging or accidentally removing parts of the organs below the adipose layers or damaging blood vessels. Moreover, most laser wavelengths used in medical procedures usually rely on water absorption, and then transferring the heat to the adipose tissue. Adipose tissue actually has very little water content. Therefore, use of these other laser wavelengths would heat the organ tissue or blood, which could lead to damaging the organ tissue or blood vessels while trying to remove the adipose surrounding the organ. Compared with using liposuction or other laser wavelengths relying in on water absorption, using lasers at wavelengths where the adipose tissue absorption exceeds water absorption (e.g., around 1210nm, 1720nm or 2300nm) could be advantageous for removing adipose around organs while minimizing damage to the organs or blood vessels.

**[0132]** In one preferred embodiment, a cascaded Raman oscillator operating near 1720nm may be used to the first overtone band of the fatty acid band (c.f. FIGURE

19). In another embodiment, a cascaded oscillator operating near 1210nm or 2300nm could also be used to remove or damage the adipose tissue. A light source near 3400-3500nm could also be used, although in this wavelength range has more water absorption, so care should be taken to avoid water between the laser emission point and the adipose tissue. Although cascaded Raman oscillators are mentioned, other lasers could also be used consistent with the disclosure. For example, laser diodes, fiber lasers, quantum cascade lasers, solid state lasers, or modelocked lasers could also be used in the therapeutic procedures.

**[0133]** In one preferred embodiment, the mid-infrared laser light can be injected into the adipose tissue around an organ through a catheter or laparoscopic device. For example, FIGURE 20 illustrates a laparoscopic device 2000 that might be used to access the visceral fat depots. In this embodiment, three exemplary devices are used: a camera probe for visualization 2001, 2002, a tweezer system for grabbing or holding tissue 2003, 2004, and a catheter 2005, 2006 with a light source with a fiber 2007 and possibly a suction pipe 2008. The catheter 2005, 2006 can include a fiber optic cable to guide the mid-infrared light from the laser system to the end of the catheter probe, and this fiber should be able to transmit the laser wavelengths. There can also be a lens system at the end of the fiber optic cable 2007 to collimate or focus the light at a desired distance from the probe end. The catheter can be guided to the area of interest in the body using an imaging system, such as an x-ray system or a camera based system. In one embodiment, as shown in Figure 21, the catheter probe can include a radio opaque tip to help identify the catheter location using x-rays. It may be advantageous to also have a camera system in the catheter, similar to what is usually used in endoscopes. That way the operator can watch on an external monitor as the fatty tissue is damaged or melted and as the interface with the organ surface is reached. In one embodiment where the catheter may be used with relatively large pockets of fatty tissue, it may also be advantageous to have a pipe and vacuum system (e.g., a liposuction apparatus) to remove the melted or damaged fat from in front of the catheter. For example, this can avoid the self-limiting of the damage or melting process, since the fat in front may block further penetration by the mid-infrared laser light.

**[0134]** Beyond using mid-infrared lasers for visceral fat, there are many examples of lipid, adipose, or fat accumulation or growth on the outside of organs that could also benefit from laser treatment. As another example, there is much clinical data that suggests that obese patients grow a layer of adipose tissue around the heart. This epicardial adipose tissue is believed to be responsible for many of the heart ailments associated with obese patients. It is also believed that the body may react to the additional adipose tissue or the adipose tissue itself may emit different chemicals, such as cytokines or macrophages. By using laser light near one of the absorption

peaks in adipose tissue, the adipose tissue can be damaged or melted. One concern in such a procedure is that the fat is damaged with minimal damage to the heart muscle. Thus, a procedure is desired that melts the fat, but that can be reasonably halted before reaching the heart muscle.

**[0135]** In the case of melting or damaging adipose tissue around the heart, the selectivity of the laser and its wavelength is desirable to distinguish between the adipose tissue and the cardiac muscle. Cardiac muscle is a type of involuntary striated muscle found in the walls of the heart, specifically called the myocardium. As an example, the transmission (1 minus the absorption in the sample) 2200 through myocardium (heart muscle) 2201, fatty tissue (adipose) 2202 and aorta 2203 is shown in FIGURE 22 (note that the scale is in arbitrary units). As shown in FIGURE 7, the fatty tissue has an absorption peak around 1720nm. FIGURE 22 shows, however, that the myocardium 2201 has a local dip in absorption (i.e., local peak in transmission) between approximately 1600nm and 1800nm. Also, most of the dips in the transmission spectra from myocardium 2201 and aorta 2203 can be attributed to water absorption bands at 0.97, 1.19, 1.45 and 1.94 microns (pointed out by the longer arrows in FIGURE 22). On the other hand, fatty tissue has different spectral signatures with dips near 0.93, 1.04, 1.21, 1.39, 1.72, 1.76, 1.92 and 2.14 microns, which are indicated by the shorter arrows in FIGURE 22. Therefore, selective damage or ablation of fatty tissue 2202 can be done in the wavelength window near 1720nm, since the myocardium 2201 has a local minimum in absorption around this range. In one embodiment, the laser power near 1720nm can be reduced as the interface between the adipose and the heart muscle is approached. With the difference in absorption between the adipose and myocardium, the damage to the myocardium can be at least minimized. In another embodiment, it may also be desirable to introduce local cooling, so that the heat transfer into the myocardium tissue from the adipose is also reduced.

#### *Applications In Cardiology For Diagnostics And Therapeutics*

**[0136]** As another example, obesity and excess adipose tissue can also lead to many cardiovascular disorders. For example, atherosclerosis is one example of an ailment associated with plaque build-up in the arteries. In 2009, it is estimated that atherosclerosis causes 650,000 deaths in the US annually, and approximately 17 million deaths worldwide. Most existing techniques for examining plaque are based on morphology of plaques, such as the constriction of the arteries. However, it is estimated that only about 15% of the heart attacks result from plaque that grows to the point of constricting blood flow.

**[0137]** By using wavelengths in the mid-infrared, particularly wavelengths between about 1.5 microns and 4.5

microns, in one embodiment it may be possible to perform diagnostics of atherosclerosis by examining chemical signatures more so than morphology. To detect so-called vulnerable plaque, the chemical signatures could be used to distinguish normal aorta walls from plaque, even potentially distinguish stable from unstable plaque.

**[0138]** In one particular embodiment, a mid-infrared SC light source has been used to perform diagnostic spectroscopy of the constituents of atherosclerotic plaque. For example, FIGURE 17 illustrates some of the differences between normal artery 1700 and atherosclerotic plaque build-up in an artery 1750. A normal tissue 1700 has smooth muscle cell 1701 with an endothelium layer 1702 on the inside of the artery 1700. In an artery with atherosclerotic plaque 1750, the endothelium layer 1751 may be damaged, and there can also be a thin layer of fibrous cap 1752 separating the endothelium 1751 from the plaque 1753. The atherosclerotic plaque 1753 comprises a number of constituents, including smooth muscle cells 1754, active macrophages and foam cells 1755 and lipids, calcium and cellular debris. Thus, a normal artery 1700 has a different composition than atherosclerotic artery 1750, and the two may be distinguished based on different optical absorption spectra. Moreover, light that is selectively absorbed in the lipid-rich plaque 1753 may be able to damage the plaque, or at least render it less active in creating biochemical reactions in the body.

**[0139]** In one non-limiting example, mid-IR absorption spectra of the components of normal artery, which includes endothelial cells 1801 and smooth muscle cells 1802, are illustrated in FIGURES 18(a) and (b). As the compositional elements of the normal artery, endothelial cells 1801 and smooth muscle cells 1802 exhibit similar absorption features in the 2.6-3.8  $\mu\text{m}$  wavelength range. A broad absorption feature ranging from 2.8-3.2  $\mu\text{m}$  and peaking at  $\sim 3050$  nm is observed, and this can be attributed to the vibrational bands of O-H stretching in the hydroxyl group and N-H stretching present in the protein amino acids.

**[0140]** The absorption spectra for some of the constituents of plaque, including macrophages 1803, adipose tissue 1804, and foam cells 1805 are illustrated in FIGURE 18(c), (d) and (e). In the lipid-rich samples, including adipose tissue 1804 and foam cells 1805, the individual absorption lines can be distinguished in the 3.2-3.6  $\mu\text{m}$  windows, e.g. =CH stretching vibration at  $\sim 3330$  nm,  $\text{CH}_3$  stretching vibration at  $\sim 3390$  nm, and  $\text{CH}_2$  stretching vibration at  $\sim 3420$  nm and  $\sim 3510$  nm. In addition, while the macrophages 1803 exhibit a similar absorption spectrum as compared to the normal artery cells 1801 and 1802, prominent spectral characters between  $\sim 3.2$  to  $3.6$   $\mu\text{m}$  with two absorption peaks at  $\sim 3420$  nm and  $\sim 3510$  nm are observed in the macrophages-transformed foam cells 1805 and adipose tissue 1804 absorption spectra. Such spectral pattern may arise from the absorptions of hydrocarbon chains, e.g.  $\text{CH}_2$  and  $\text{CH}_3$  bonds, present in both the fatty acids and cholesterol esters, both of

which fall in the adipose tissue category. Therefore, the spectral difference between the macrophages 1803 and foam cells 1805 is consistent with the pathological relationship between these two cell types, i.e. macrophages engulf lipid-rich substances to become foam cells.

**[0141]** To further investigate the composition properties of the constituents of plaque, the absorption spectrum has been measured of egg yolk 1901, which is considered to be a conventional composite model of atherogenic lipoprotein. The spectral character of egg yolk 1901 (FIGURE 19), shares many similarities with that of foam cells 1805 (see FIGURE 18(e)). Compared to endothelial cells 1902 and smooth muscle cells 1802, which form the normal artery, egg yolk 1901 shows distinct lipid-rich absorption features in 3.2-3.6  $\mu\text{m}$  wavelength range while having comparable absorptions in the 2.8-3.2  $\mu\text{m}$  O-H and N-H vibrational bands.

**[0142]** Although the example of FIGURES 18 and 19 show that a large absorption peak can be observable from adipose tissue between approximately 3400 to 3500nm, one problem with performing diagnostic in this wavelength range is that the water and blood absorption can be very strong (in this wavelength range, the absorption for blood and water are approximately equal). For instance, at 3400nm the water absorption is approximately  $700\text{cm}^{-1}$ , and even at 3500 nm the water absorption is about  $334\text{cm}^{-1}$ . Therefore, it might be difficult to perform spectroscopy of the atherosclerotic plaque without either putting the probe directly in contact with the endothelium layer or pausing the blood and water flow through the artery.

**[0143]** In a preferred embodiment, the diagnostics or spectroscopy of the plaque can be performed in the first overtone wavelength range, for example in the wavelength range between 1300 and 1900nm, more preferably in the wavelength range between 1700nm and 1750nm. Similar to FIGURES 18 and 19, spectral features will be observable in this first overtone window, but one advantage can be that the water and blood absorption may be considerably weaker. For example, the water absorption coefficient at 1700nm is about  $5.15\text{cm}^{-1}$ , while at 1750nm the absorption coefficient is approximately  $6.4\text{cm}^{-1}$ . The lower water and blood absorption can make it more likely to perform spectroscopy in this wavelength range.

**[0144]** As another embodiment of diagnostics or spectroscopy in cardiovascular medicine, broadband sources in the mid-IR can also be used with abdominal aortic aneurysms (AAA). An abdominal aortic aneurysm is exemplary when the large blood vessel that supplies blood to the abdomen, pelvis and legs becomes abnormally large or balloons outward. The type of plaque considered most vulnerable to disruption is a thin-capped fibroatheroma with increased inflammatory cell content. A thin-capped fibroatheroma typically has a cap thickness of less than 100 microns and a lipid core accounting for greater than 40% of the plaque's total volume. Plaque rupture is among the most frequent type of plaque complication,

accounting for an excess of 70% of fatal acute myocardial infarctions and sudden coronary deaths.

**[0145]** Collagen and elastin are major structural components of vessel walls that have been widely implicated in aneurysm formation, progression and rupture. For example, the most prevalent structural modification associated with human AAA's that has been reported is a reduction in elastin concentration in the aortic wall. Also, increased collagen concentration is another matrix modification that has been widely observed in human AAA's. It can be noted that Collagens I and III are the principal collagen components of the aorta. The mid-infrared spectra for collagens and elastins are illustrated in FIGURE 7, and changes in the optical spectra could be used to potentially diagnose the presence of plaque and changes associated with AAA in the aorta walls. For example, as the ratio of collagen to elastin changes, the optical spectrum in the wavelength range above 1000nm will also change. In a preferred embodiment, the optical spectrum between 1400nm and 1800nm can be measured, and changes in the spectral shapes can be correlated with the ratio of collagen to elastin. For example, spectral fingerprinting or some sort of principal component analysis can be performed on absorption, transmission or reflection data to distinguish between different ratios of collagen and elastin.

**[0146]** As yet another example of using light from SC sources for diagnostics, SC light in the near-infrared can be used to screen for or diagnose colorectal cancer or pancreatic cancer. Colorectal cancer is the fourth most common form of cancer in the U.S. and the third leading cause of cancer-related death in the Western world. One area in need of improvement is accuracy in detection of flat polyps, or fat dysplasia that does not necessarily protrude out of the mucosa. Whereas adenomatous polyps can readily be detected visually using the fiber optic and CCD cameras in endoscopes, flat polyps can be missed, thus increasing the risk of colorectal cancer despite early screening. Moreover, there are diseases such as ulcerative colitis, which is a form of inflammatory bowel disease that do not lead to the outgrowth of polyps. If this disease is suspected, the only diagnostic is to acquire many biopsy samples. Therefore, a technique is required for detecting flat polyps based on their chemical or compositional signatures to distinguish normal mucosa from cancerous tissue.

**[0147]** Colorectal cancer can be distinguished from the normal mucosa by examining the chemical differences in tissue composition using reflection spectroscopy in the near-infrared wavelength range. The differences in tissue composition between colorectal cancer and normal tissues have been extensively analyzed using chemical, histochemical, biochemical and immunohistochemical studies. It has been shown that adenoma and carcinoma of colorectal tissues have altered compositions in fatty acids, carbohydrates, glycosaminoglycans, glycoproteins and glycolipids. In particular, the lipid near-infrared absorption bands provide diagnostic markers useful for

colorectal and pancreatic cancer diagnosis. More specifically, due to the rapid proliferation of cancerous cells, there is reduced lipid content in adenoma and carcinoma colorectal tissues.

5 **[0148]** Prior studies have looked for the missing lipid lines through spectroscopy either in the mid-infrared (e.g., 2000 to 5000nm) or near-infrared (e.g., 1600 to 1800nm). The mid-infrared light shows strong signals at the fundamental absorption bands, but the water absorption is much stronger and prevents imaging in a realistic endoscopic setting. In contrast, although absorption changes are smaller in the near-infrared wavelength range, the near-infrared light can transmit through water. Moreover, near-infrared spectroscopy can use standard glass fiber used in the telecommunications industry, which makes it much simpler to transport through the endoscope by addition of a fiber or a bundle of fibers.

10 **[0149]** In one embodiment, a screen for colorectal cancer may be achieved by adding to an endoscope or a colonoscopy device fibers for reflection spectroscopy in the near-infrared wavelength range. In one embodiment, one or more fibers may be used for illuminating the sample, and then one or more fibers may be used for capturing the reflected signal and bringing back through the endoscope. At the end of the illumination fiber, mirrors or lens may be used to focus or collimate light onto the walls of the colon or large intestines. In a particular example, the illumination and return fibers may form a fiber bundle. In another example, the same fiber may be used for illumination and return of the signal. Once the reflected signal is transported back through the endoscope, the signal can be analyzed using a series of detectors or a spectrometer followed by one or more detectors. For example, an optical spectrum analyzer might be used to look at the signal strength as a function of wavelength.

15 **[0150]** In a particular embodiment, the spectroscopy can be conveniently performed using a near-infrared SC laser such as in FIGURE 12 that can generate light between 1600 and 1800nm, a wavelength window with multiple C-H first overtone absorption lines and a minimum in water absorption and scattering. With the broadband light, spectral fingerprinting can be performed for inspection of the lipid lines, and the sensitivity can be improved by taking the derivative of the reflected light as a function of wavelength. For example, the SC laser can be coupled to a transmission or illumination fiber, which is used to transport the light from the SC laser to the end of the endoscope for sample inspection. The output from the fiber-based SC laser can be conveniently coupled to a fiber, and a separate fiber is used for illumination any contamination from the endoscope or sample does not affect the SC laser. This permits, for example, the illumination and reflected sample fibers to be used on a patient and then discarded.

20 **[0151]** As an example, the first overtone of the lipid absorption lines fall in the near-infrared, and vibrational spectroscopy shows weaker but distinct changes between 1670 and 1790nm. In particular, normal tissue can

show distinct lipid lines, but the lines reduce in strength for cancerous tissue. For instance, FIGURE 23 illustrates the changes in the near-infrared reflection data between normal 2301 and cancerous 2302 pancreatic tissue, and between normal 2303 and cancerous 2304 colorectal tissue. The differences can be further enhanced by taking a derivative of the data. For instance, for pancreatic tissue the derivatives for normal 2305 and cancerous 2306 tissue are shown, while for colorectal tissue the derivatives for normal 2307 and cancerous 2308 tissue are shown. In one embodiment for colorectal cancer, the inset 2309 overlays the derivative data between approximately 1670nm and 1790nm for normal 2311 and cancerous tissue 2310. Moreover, the inset 2302 shows derivative spectra for colorectal cancer for different degrees of progress toward cancer. In this example, the normal tissue spectrum is 2313, the cancerous tissue spectrum is 2314, and different curves in between represent different degrees of progress toward a cancerous state. Thus, for the case of colorectal or pancreatic cancer in this example, the spectral signature falls within a minimum in water scattering and absorption from FIGURES 6 or 7, so the spectral data should be observable through a colonoscopy procedure.

**[0152]** Spectroscopy, similar to that of FIGURES 18 and 19 in either the fundamental wavelength window between 2600nm and 3800nm or the first overtone can be performed using supercontinuum lasers based on fibers. For spectroscopy in the fundamental range around 2600-3800nm, a ZBLAN-fiber based SC source can be used. On the other hand, for spectroscopy in the first overtone window between approximately 1400 and 1800nm, a fused-silica or high-nonlinearity fiber based SC source can be used. Alternatively, other broadband lasers with the appropriate wavelength ranges can also be used. In one embodiment, the SC laser light can be coupled to a catheter, which can then be inserted into the artery to perform the diagnostic spectroscopy. In one preferred embodiment, to inspect for plaque inside an artery, a periscope-type catheter that can be rotated approximately 360 degrees may be required.

**[0153]** In one preferred embodiment, absorption or reflection spectroscopy could be performed by coupling the SC light into a catheter 2100 designed using primarily reflective optics. One advantage of using reflective optics is that it can be broadband, and, therefore, be compatible with SC light. As an example, FIGURE 21 illustrates a single-mode ZBLAN fiber 2101 based endoscopic catheter 2100 that uses achromatic reflective optics 2102 and allows noncontact measurement. If wavelengths beyond 2.5 microns are used, then mid-infrared fibers, such as ZBLAN, tellurite, fluorides or chalcogenides, can be used advantageously in the probe. If wavelengths shorter than 2.5 microns are used, then the single-mode fiber can be made out of more standard material, such as fused silica. In addition, a radio opaque tip 2104 could be installed in the front end of the catheter 2100 for the position guidance. For instance, x-ray or some other type of imaging

system could be used to monitor the position of the catheter tip 2104 and to guide it to the desired location in the body.

**[0154]** The catheter of FIGURE 21 comprises at least three main components, i.e. a single mode fiber 2101, a 90 degree off-axis micro concave mirror 2102, and a rotational micro-motor 2103. In this embodiment, the mid-IR light emitting from the angle-cleaved fiber tip 2105 can be first re-directed by 90 degrees and collimated by the concave mirror 2102. If it is desired to confine the collimated beam diameter to the order of ~100-200  $\mu\text{m}$ , the radius curvature of the micro concave mirror could be ~250  $\mu\text{m}$ . In one embodiment, the micro-mirrors could be fabricated and implemented by MEMS techniques on silicon substrate with gold coating. The concave mirror 2102 could be mounted onto a 1 mm diameter rotational micro-motor to enable the 360-degree peripheral optical scan. As an example, the miniature catheter of FIGURE 21, which could also be disposable, with an outer diameter of ~1 mm could be mechanically coupled to the output pigtail of a SC laser to construct an integrated, minimally invasive *in vivo* reflective absorption spectroscopy and laser ablation system. Although one example is provided of a catheter probe 2100, other designs could be used consistent with the elements of this disclosure. For example, other mid-IR catheters include hollow glass waveguide catheters, germanium oxide fiber catheters, or catheters employing large core multimode fibers.

**[0155]** Beyond reflection or absorption spectroscopy, other types of optical measurements can also be used. In one non-limiting example, an interferometric system can be used to measure thickness of various elements, thereby providing morphological information in addition to chemical composition information. For instance, an optical coherence tomography system, which is basically a Michelson interferometer, can be used with the SC light source to measure the thickness of the fibrous cap. As described above, when the fibrous cap becomes thinner than about 100 microns, there is an increased risk of rupture. More particularly, a fibrous cap thickness of order of 65 microns is considered to be of high risk, potentially being in the category of so-called vulnerable plaque.

**[0156]** To perform therapeutic procedures, it may be more desirable to use narrower-band, higher power (or higher spectral density) lasers. For example, to perform the diagnostics or spectroscopy, a broadband laser is advantageous, and a supercontinuum light source is one example of a convenient light source. On the other hand, for therapeutics, where the desire may be to damage selectively on or more compositional elements, it may be more desirable to use a narrower band, higher power light source such as a cascaded Raman oscillator. As an illustration, one therapeutic procedure may be to damage selectively the lipid-rich plaque core lying under the endothelium and fibrous cap (FIGURE 17). In one preferred embodiment, a cascaded Raman oscillator operating near 1720nm may be used to the first overtone band of the fatty acid band (c.f. FIGURE 19). A light source near

3400-3500nm could also be used, although in this wavelength range has more water absorption, so care should be taken to avoid water between the laser emission point and the plaque. Although cascaded Raman oscillators are mentioned, other lasers could also be used consistent with the disclosure. For example, laser diodes, fiber lasers, thulium-doped fiber lasers, quantum cascade lasers, solid state lasers, or modelocked lasers could also be used in the therapeutic procedures.

**[0157]** Although the above discussion has described one example of using the mid-infrared laser light in cardiovascular organs, there are many other situations where the laser procedure can be beneficial by selectively absorbing in adipose, collagen or elastin. In yet another embodiment, there is a growing need for percutaneous valve replacement, for example with the aortic or pulmonary valves. When an artificial stent or valve is placed in the body, it may also be desirable for the collagen to cross-link and secure the stent or valve in place. By using mid-infrared light near the stent or valve, collagen contraction can occur locally, and the heat generated in the collagen can also promote collagen cross-linking. There may be a further advantage of also heating the elastin locally in the vicinity of the stent or valve.

**[0158]** In yet another embodiment, the mid-infrared laser light could be used to minimize collateral damage for procedures in the brain. For example, mid-infrared laser light could be used for selective laser ablation for removing tissue obstructions in shunt catheters used in hydrocephalus. Hydrocephalus is defined as an excessive accumulation of cerebrospinal fluid (CSF) within the cavities of the brain known as ventricles. Hydrocephalus is one of the more common childhood brain disorders, with an incidence as high as 1/500 births. Hydrocephalus is usually a lifelong condition, and the standard treatment involves diverting ventricular CSF through a surgically implanted silicone catheter with a pressure-controlled valve (shunt) into the abdominal cavity, where it is reabsorbed along the belly wall. The number one problem of the shunt is blockage due to tissue growing into the drainage holes, which line the side of the silicone tube. Because of the side placement of the drainage holes, it is virtually impossible to clear the blockage mechanically. Moreover, the same blockage problem is common to any catheter implanted in the body, such as those also used to deliver drugs along the spinal cord or drain abscesses.

**[0159]** As an example, using the mid-infrared light a fiber-based "rotor-rooter" can be implemented to clear the blockage in the shunts by using the selective absorption in the blockage material versus silicone rubber shunts. In fact, silicone rubber can be fairly transparent out to wavelengths longer than 8.58 microns. Standard fiber with 125 micron cladding and 250 micron diameter with coating should easily fit within most of the shunts, which are typically 1-2 mm inner diameter. Moreover, the end of the fiber can be etched or cleaved to emit light at 45 degrees, enabling light delivery to the drainage holes. In one embodiment, a tip design similar to FIGURE 21

could be used. By selectively ablating the tissue blocking the shunt drainage holes, the blockage can be removed without requiring surgical removal of the shunt and without damaging the walls of the shunt. It is desirable also not to damage brain tissue just outside the drainage holes.

**[0160]** As yet another example, the mid-infrared light could be used to detect cancerous tumors in the brain. In particular, brain tissue is characterized by high lipid content. The amount of lipids decreases, and its composition changes in the most frequent primary brain tumor, the glioma. For example, spectroscopy of brain tissue has shown that gliomas are characterized by increased water content and decreased lipid content. Based on the different spectra from lipids and water, such as shown in FIGURES 6 and 7, spectral changes should be present for gliomas versus normal brain tissue. In one embodiment, a fiber probe could be inserted into suspect areas of the brain, and light from the brain tissue could be reflected (potentially transmitted, if, for example, two probes are used) to perform reflection spectroscopy. The light could be from a super-continuum fiber laser operating in the range of approximately 1600 to 1800nm, and the reflected light could be analyzed using a spectrometer. The changes in spectra could also be enhanced by taking a derivative of the reflection data as a function of wavelength. Reflection data from different parts of the brain tissue could be compared. As an example, the normal brain tissue should have lipid lines in the spectra, while the glioma regions should have reduced lipid lines and enhanced water lines. By performing such differential spectroscopy, the boundary between normal and tumor brain tissue could be better demarcated.

**[0161]** Beyond detecting cancerous regions in the brain or central nervous system, mid-infrared light could also be used to cut brain or central nervous system tissue with minimal collateral damage. The precise cuts could be achieved by tuning into lipid lines, and then cutting tissue that is lipid rich. In contrast, many laser cutting procedures rely on absorption in water. First, relying on water can be non-selective, since most tissue has significant water content. Second, as the water in cells is heated, the water in the cells expands as it turns to vapor, causing the cells to rupture. Consequently, water-based heating can lead to significant collateral damage in the surrounding tissue, which would be particularly undesirable for operation in brain tissue or nervous system tissue.

**[0162]** In one embodiment, more precise cuts for tissue of the central nervous system or brain tissue could be accomplished by using a laser tuned near 1720nm or one of the other wavelength peaks in adipose absorption. As an example, myelin is a dielectric material that forms a layer, the so-called myelin sheath, usually around the axon of a neuron. Myelin made by different cell types varies in chemical composition and configuration, but it still performs the same kind of insulating function. Myelinated axons are white in appearance, hence the term

"white matter" of the brain. In particular, myelin is composed of about 80% lipid and about 20% protein. As a consequence, a laser tuned to one of the lipid absorption peaks (FIGURES 6 and 7) could be used to cut myelin regions of the brain or central nervous system with higher precision than a laser tuned to a water line. For example, a fiber could be directed to the region of interest for performing the cut in the tissue. Then, using a cascaded Raman wavelength shifter that emits light near 1720nm, the light could be used to heat the adipose-rich tissue and provide a clean cut. There should result less damage to the surrounding tissue with less lipid content, resulting in less collateral damage. As an alternative, it may also be desirable to use another wavelength tuned to adipose, such as wavelengths near 2300nm (c.f. FIGURE 7). Because of the higher absorption near the 2300nm wavelength, the penetration depth can be less, leading again to a more precise cut. This is just one example of accomplishing a clean cut based on tuning to one of the absorption resonances of particular tissue types, such as adipose, collagen or elastin. There are many other parts of the body which can benefit from the precise cuts beyond the brain.

**[0163]** Described herein are just some examples of the beneficial use of mid-infrared laser treatment based on the selective absorption in adipose, collagen and elastin. However, many other medical procedures can use the mid-infrared light consistent with this disclosure and are intended to be covered by the disclosure.

**[0164]** Some features of at least some examples of embodiments of the invention are as follows:

1. catheter based procedure for treatment of obesity related ailments

a. laser light selectively absorbed in adipose tissue surrounding internal organs, wherein the wavelength of the laser light coincides approximately with a local maximum in absorption in adipose

b. local minimum in loss from water absorption and scattering in tissue

c. operate at eye safe wavelengths, operate at wavelength near 1720nm

d. light is generated by a fiber laser pumped by laser diodes

e. catheter includes fiber optic cable capable of transmitting the light and piping to remove adipose damaged in procedure

2. fiber laser is a thulium-doped fiber laser or an erbium-doped fiber laser followed by a cascaded Raman wavelength shifter

3. remove or damage adipose without substantially damaging tissue of organ

4. visceral fat, intra-peritoneal fat, and abdominal fat

5. fat associated with ailments associated with type 2 diabetes or cardiovascular ailments or diseases

6. local cooling to localize damage

7. damage to adipose tissue results in reduction or stopping of cytokines and other chemicals being emitted by adipose tissue

8. catheter also includes lens system, imaging system, camera system

9. light based procedure for treatment of obesity related ailments

a. laser light selectively absorbed in adipose tissue surrounding internal organs, wherein the wavelength of the laser light coincides approximately with a local maximum in absorption in adipose

b. local minimum in loss from water absorption and scattering in tissue

c. remove or damage adipose without substantially damaging tissue of organ

d. damage to adipose tissue results in reduction or stopping of cytokines and other chemicals being emitted by adipose tissue

10. visceral fat, intra-peritoneal fat, and abdominal fat, fat associated with ailments associated with type 2 diabetes or cardiovascular ailments or diseases

11. organ is heart, and adipose tissue is damaged without substantial damage to myocardium and smooth muscle cells

12. laser wavelength is approximately 1720nm in the eye safe zone

13. light is generated by a fiber laser pumped by laser diodes

14. (13+) fiber laser is a thulium-doped fiber laser or an erbium-doped fiber laser followed by a cascaded Raman wavelength shifter

15. catheter used for percutaneous procedure, catheter includes fiber optic for delivering mid-infrared light, imaging or camera system, and suction means for removing damaged adipose tissue

16. catheter based procedure for treatment of obesity related ailments

- a. laser light selectively absorbed in adipose tissue surrounding internal organs, wherein the wavelength of the laser light coincides approximately with a local maximum in absorption in adipose as well as approximately local maximum in absorption for collagen and elastin 5
- b. local minimum in loss from water absorption and scattering in tissue 10
- c. operate at eye safe wavelengths, operate at wavelength near 1720nm 15
- d. remove or damage adipose without substantially damaging tissue of organ
- e. catheter includes fiber optic cable capable of transmitting the light and piping to remove adipose damaged in procedure 20

17. light is generated by a fiber laser pumped by laser diodes, fiber laser is a thulium-doped fiber laser or an erbium-doped fiber laser followed by a cascaded Raman wavelength shifter 25

18. damage to adipose tissue results in reduction or stopping of cytokines and other chemicals being emitted by adipose tissue 30

19. visceral fat, intra-peritoneal fat, and abdominal fat, fat associated with ailments associated with type 2 diabetes or cardiovascular ailments or diseases 35

20. organ is heart, and adipose tissue is damaged without substantial damage to myocardium and smooth muscle cells 40

**[0165]** Although the present invention has been described in several embodiments, a myriad of changes, variations, alterations, transformations, and modifications may be suggested to one skilled in the art, and it is intended that the present disclosure encompass such changes, variations, alterations, transformations, and modifications as falling within the scope of the appended claims. 45

### Claims

1. A system for selectively processing biological target material, the system comprising:

- a catheter or laparoscopic device (2000, 2005, 2006),
- a laser subsystem (1050) configured to gener-

ate an output light beam along a propagation path, wherein the laser system (1050) comprises a plurality of laser diodes (1052) coupled to a proximal end of an optical fiber (1051), wherein the optical fiber comprises the proximal end and a distal end, and wherein the beam comprises one or more wavelengths being in an approximate range of 1170 to 1250nm, and a delivery head for locating a beam delivery and focusing subsystem relative to the target material, wherein the beam delivery and focusing subsystem is coupled to the distal end of the optical fiber (1051) and is disposed in the propagation path and accepts the output light beam and relatively positions the beam into a plurality of focused spots on the target material, **characterised by** the laser subsystem (1050) comprising an optical gain fiber (1051) and a plurality of pump laser diodes (1052) configured to excite the gain fiber (1051) and combined using a power combiner (1053), the combined pump laser diode power being coupled to the proximal end of the optical gain fiber (1051), and the catheter or laparoscopic device (2000, 2005, 2006) comprising the propagation path with the optical fiber.

2. The system as claimed in claim 1 where the target material is adipose tissue.

3. The system as claimed in claim 1 where the target material is collagen tissue.

4. The system as claimed in any preceding claim wherein the system further comprises a cooling mechanism for cooling the target material.

5. The system as claimed in any of claims 1-3, wherein the system further comprises a cooling mechanism disposed at the delivery head.

6. The system as claimed in any preceding claim wherein the system is configured to generate the output light beam with a pulse width of between approximately 3 and 10 seconds.

7. The system as claimed in any preceding claim wherein the laser subsystem includes at least one wavelength shifter (1075) that shifts the wavelength of the laser diode (1052) to the wavelength range of approximately 1170 to 1250nm.

8. The system as claimed in any preceding claim wherein the system comprises a laparoscopic device (2000, 2005, 2006) comprising a camera probe (2001, 2002) for visualization, a tweezer system (2003) for grabbing and holding tissue, and a suction

pipe (2008).

### Patentansprüche

1. System zur selektiven Verarbeitung eines biologischen Zielmaterials, wobei das System umfasst:

einen Katheder oder ein Laparoskop (2000, 2005, 2006),  
 ein Laser-Subsystem (1050), welches dazu konfiguriert ist, einen Ausgangslichtstrahl entlang eines Ausbreitungsweges zu erzeugen, wobei das Lasersystem (1050) mehrere Laserdioden (1052) enthält, welche an einem proximalen Ende einer optischen Faser (1051) gekoppelt sind, wobei die optische Faser das proximale Ende und ein distales Ende hat, und wobei der Strahl ein oder mehrere Wellenlängen hat, welche in einem ungefähren Bereich zwischen 1170 und 1250 nm sind, und einen Zuführkopf zum Positionieren eines Strahlzufuhr- und Fokussierungs-Subsystems in Relation zum Zielmaterial, wobei das Strahlzufuhr- und Fokussierungs-Subsystem am distalen Ende von der optischen Faser (1051) gekoppelt ist und im Ausbreitungsweg angeordnet ist und die Ausgabe des Lichtstrahls zulässt und den Strahl in eine Mehrzahl von fokussierten Punkten auf dem Zielmaterial in Relation positioniert, **dadurch gekennzeichnet, dass** das Laser-Subsystem (1050) eine optische Verstärkungsfaser (1051) und mehrere PumpLaserdioden (1052) enthält, welche dazu konfiguriert sind, die Verstärkungsfaser (1051) anzuregen und zusammen einen Leistungskoppler (1053) zu verwenden, wobei die kombinierte PumpLaserdiodenleistung an das proximale Ende von der optischen Verstärkungsfaser (1051) gekoppelt wird, und wobei der Katheder oder das Laparoskop (2000, 2005, 2006) den Ausbreitungsweg mit der optischen Faser hat.

2. System nach Anspruch 1, wobei das Zielmaterial ein Fettgewebe ist.
3. System nach Anspruch 1, wobei das Zielmaterial ein Kollagen Gewebe ist.
4. System nach einem der vorhergehenden Ansprüche, wobei das System ferner einen Kühlmechanismus zum Kühlen des Zielmaterials enthält.
5. System nach einem der Ansprüche 1 bis 3, wobei das System ferner einen Kühlmechanismus enthält, welcher am Zuführkopf angeordnet ist.

6. System nach einem der vorhergehenden Ansprüche, wobei das System dazu konfiguriert ist, den Ausgangslichtstrahl mit einer Impulsbreite zwischen ungefähr 3 und 10 Sekunden zu erzeugen.

7. System nach einem der vorhergehenden Ansprüche, wobei das Laser-Subsystem zumindest einen Wellenlängenschieber (1075) enthält, welcher die Wellenlänge von der Laserdiode (1052) auf den Wellenlängenbereich von ungefähr 1170 bis 1250 nm verschiebt.

8. System nach einem der vorhergehenden Ansprüche, wobei das System ein Laparoskop (2000, 2005, 2006) enthält, welches eine Kamerasonde (2001, 2002) zur Visualisierung, eine Pinzette (2003) zum Ergreifen und Halten von Gewebe, und eine Saugröhre (2008) enthält.

### Revendications

1. Système pour traiter sélectivement un matériau biologique cible, le système comprenant :

un cathéter ou un dispositif laparoscopique (2000, 2005, 2006),  
 un sous-système à laser (1050) configuré pour générer un faisceau de lumière sortant le long d'un trajet de propagation, dans lequel le système à laser (1050) comprend une pluralité de diodes laser (1052) couplées à une extrémité proximale d'une fibre optique (1051), dans lequel la fibre optique comprend l'extrémité proximale et une extrémité distale, et dans lequel le faisceau comprend une ou plusieurs longueurs d'onde qui se trouvent dans une plage approximative de 1170 à 1250 nm, et  
 une tête de distribution pour localiser un sous-système de distribution de faisceau et de focalisation par rapport au matériau cible, dans lequel le sous-système de distribution de faisceau et de focalisation est couplé à l'extrémité distale de la fibre optique (1051) et est disposé dans le trajet de propagation, et accepte le faisceau de lumière sortant, et positionne relativement le faisceau en une pluralité de taches focalisées sur le matériau cible, **caractérisé en ce que** le sous-système à laser (1050) comprend une fibre à gain optique (1051) et une pluralité de diodes laser pompées (1052) configurées pour exciter la fibre à gain (1051), et combinées en utilisant un combineur de puissance (1053), la puissance des diodes laser pompées combinées étant couplée à l'extrémité proximale de la fibre à gain optique (1051), et le cathéter ou dispositif laparoscopique (2000, 2005, 2006) comprenant le trajet de propagation

avec la fibre optique.

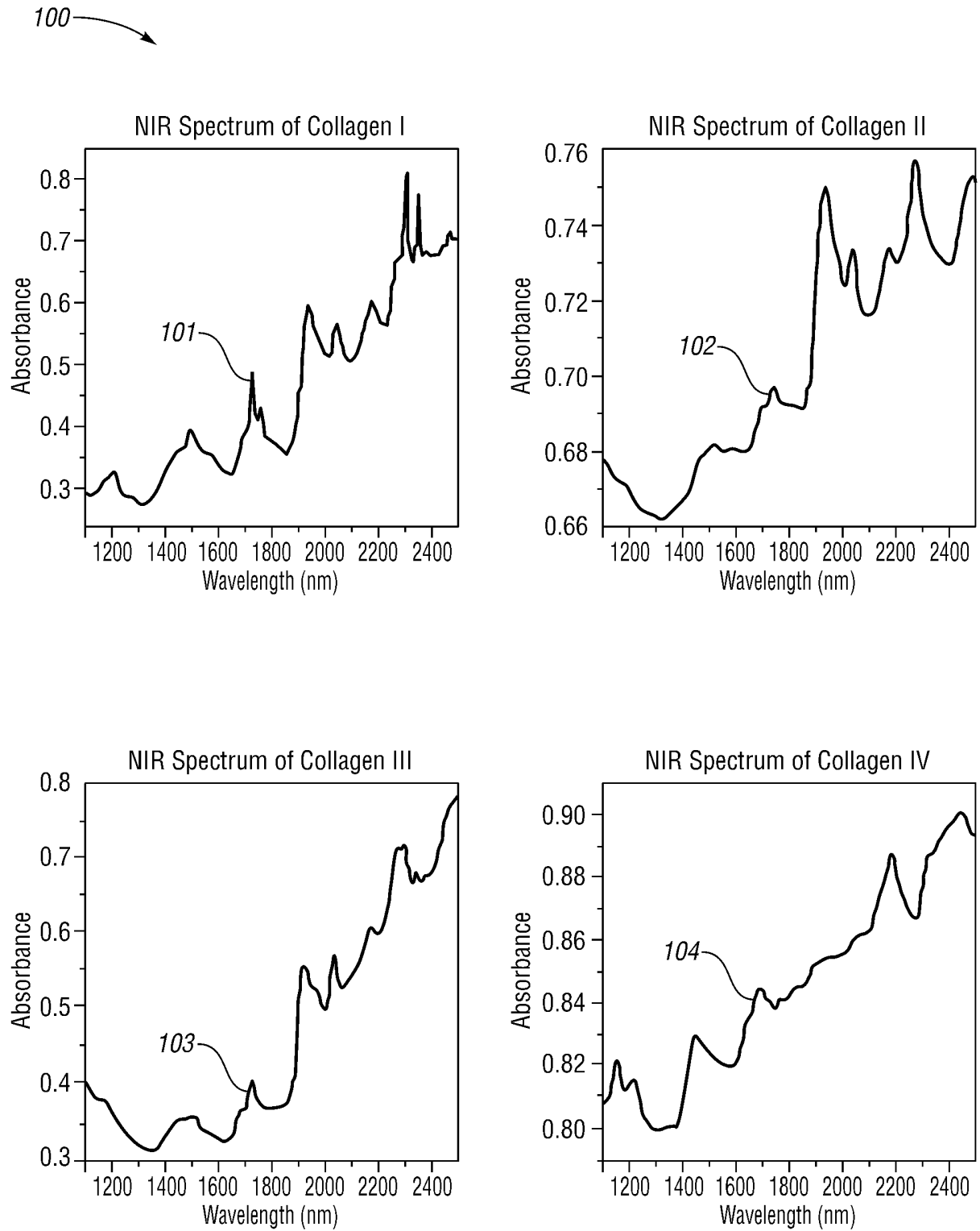
2. Système selon la revendication 1, dans lequel le matériau cible est un tissu adipeux. 5
3. Système selon la revendication 1, dans lequel le matériau cible est un tissu collagène.
4. Système selon l'une quelconque des revendications précédentes, ledit système comprenant en outre un mécanisme de refroidissement pour refroidir le matériau cible. 10
5. Système selon l'une quelconque des revendications 1 à 3, dans lequel le système comprend en outre un mécanisme de refroidissement disposé au niveau de la tête de distribution. 15
6. Système selon l'une quelconque des revendications précédentes, dans lequel le système est configuré pour générer le faisceau de lumière sortant avec une largeur d'impulsion entre approximativement 3 et 10 secondes. 20
7. Système selon l'une quelconque des revendications précédentes, dans lequel le sous-système à laser inclut au moins un dispositif de décalage de longueur d'onde (1075) qui décale la longueur d'onde de la diode laser (1052) vers la plage des longueurs d'onde d'approximativement 1170 à 1250 nm. 25 30
8. Système selon l'une quelconque des revendications précédentes, dans lequel le système comprend un dispositif laparoscopique (2000, 2005, 2006) comprenant une sonde à caméra (2001, 2002) pour la visualisation, un système à pincette (2003) pour creuser et pour tenir des tissus, et un tube de succion (2008). 35

40

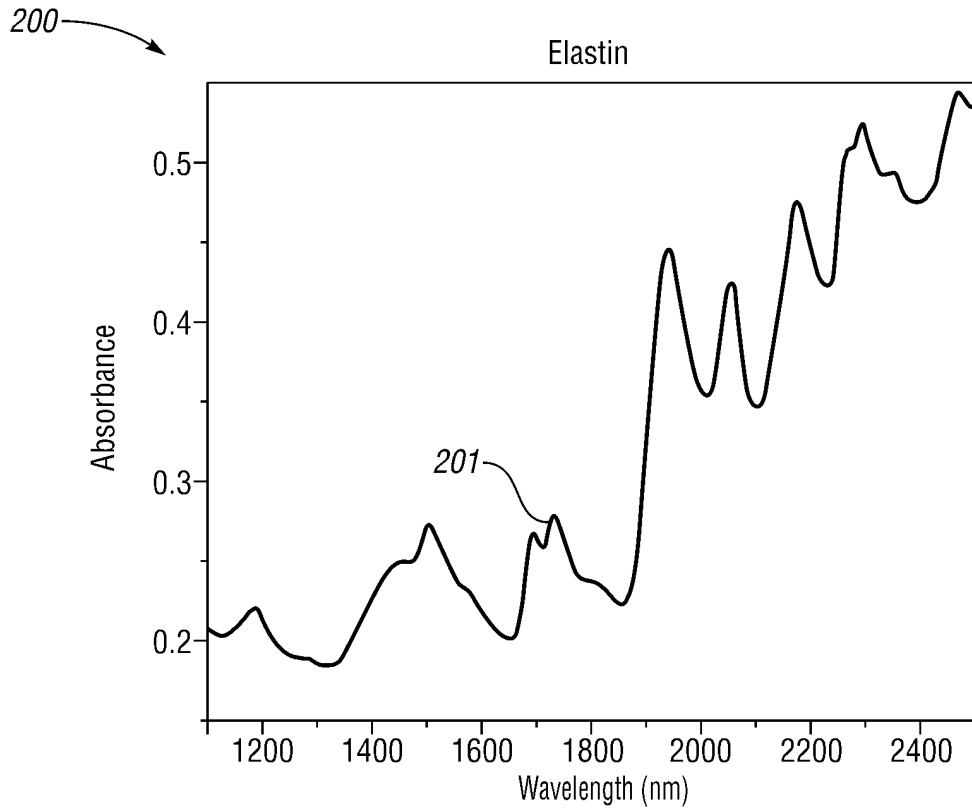
45

50

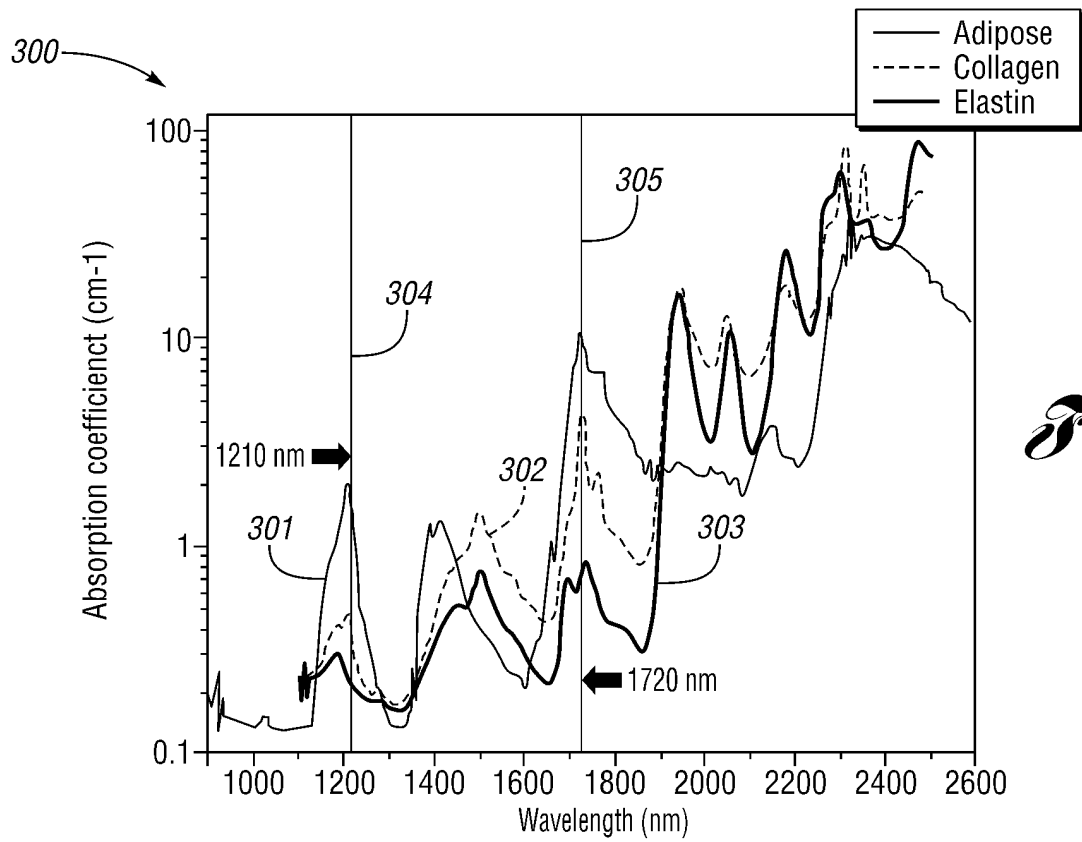
55



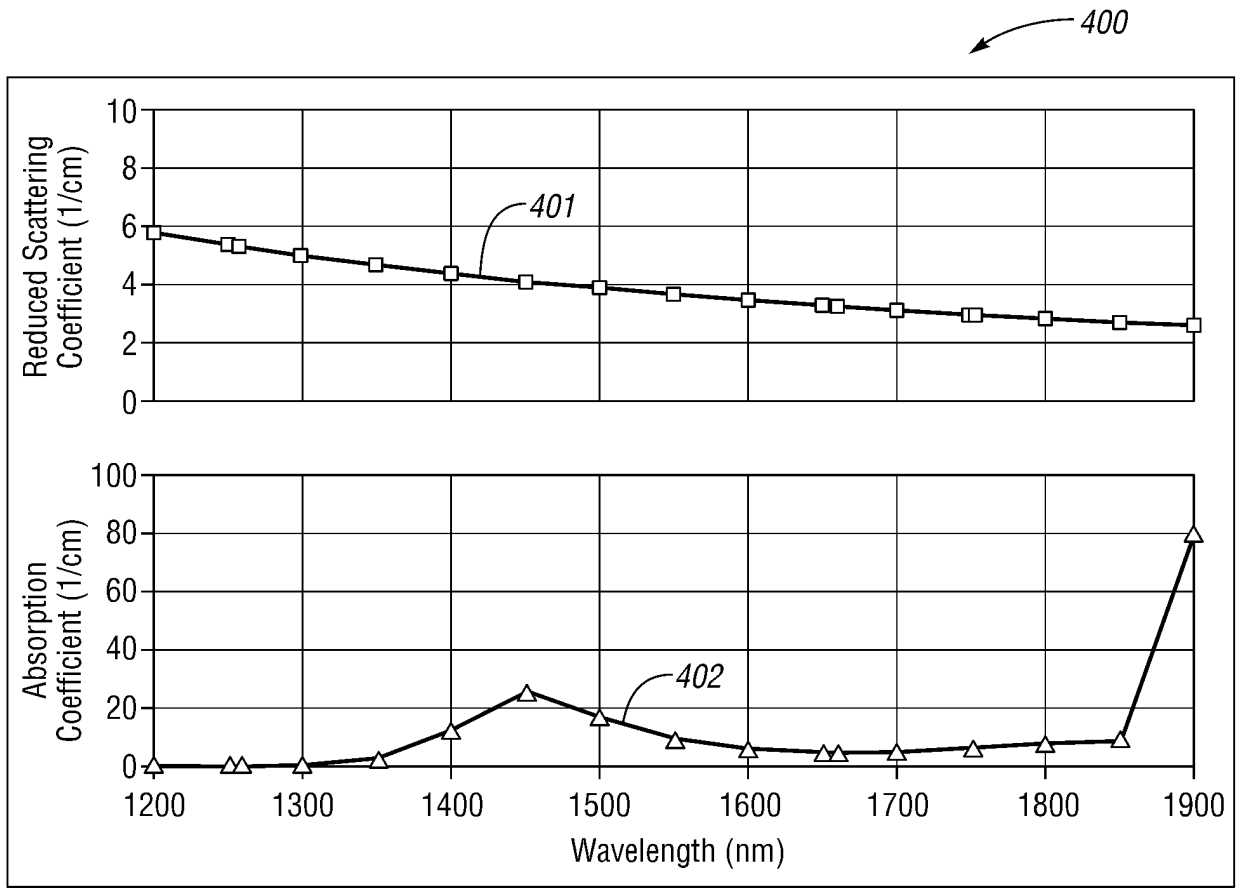
*Fig. 1*



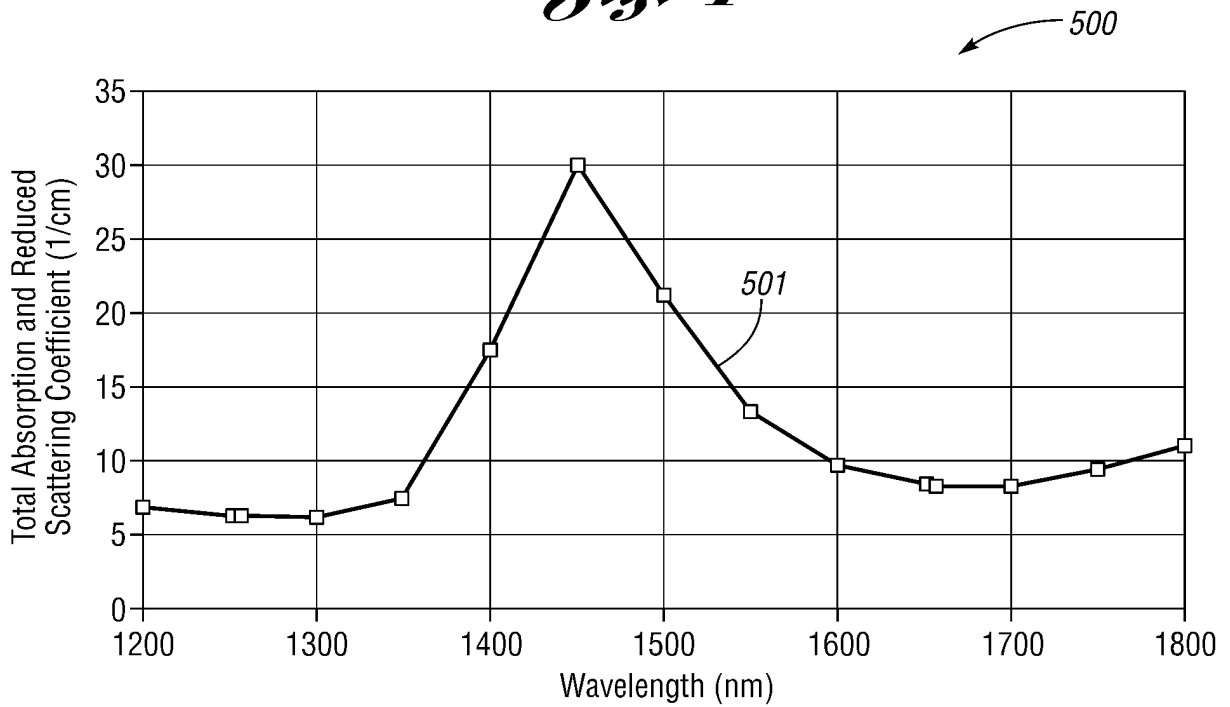
*Fig. 2*



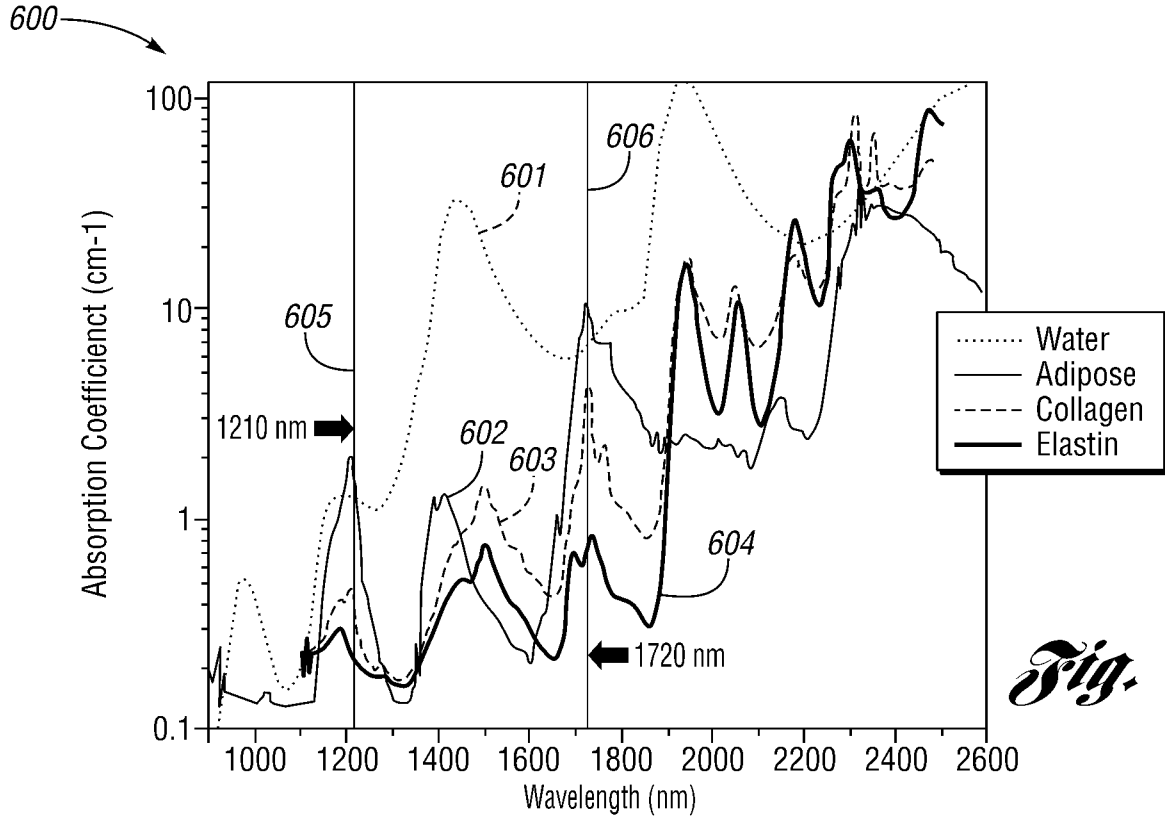
*Fig. 3*



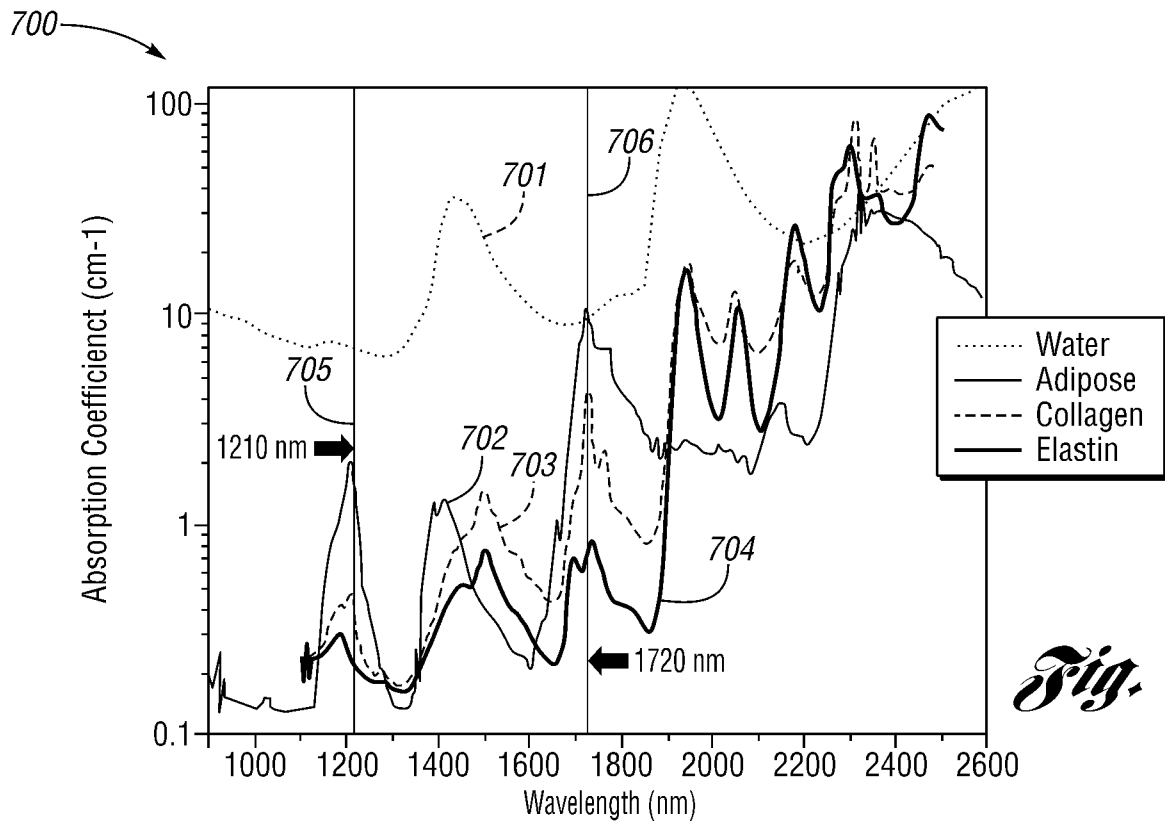
*Fig. 4*



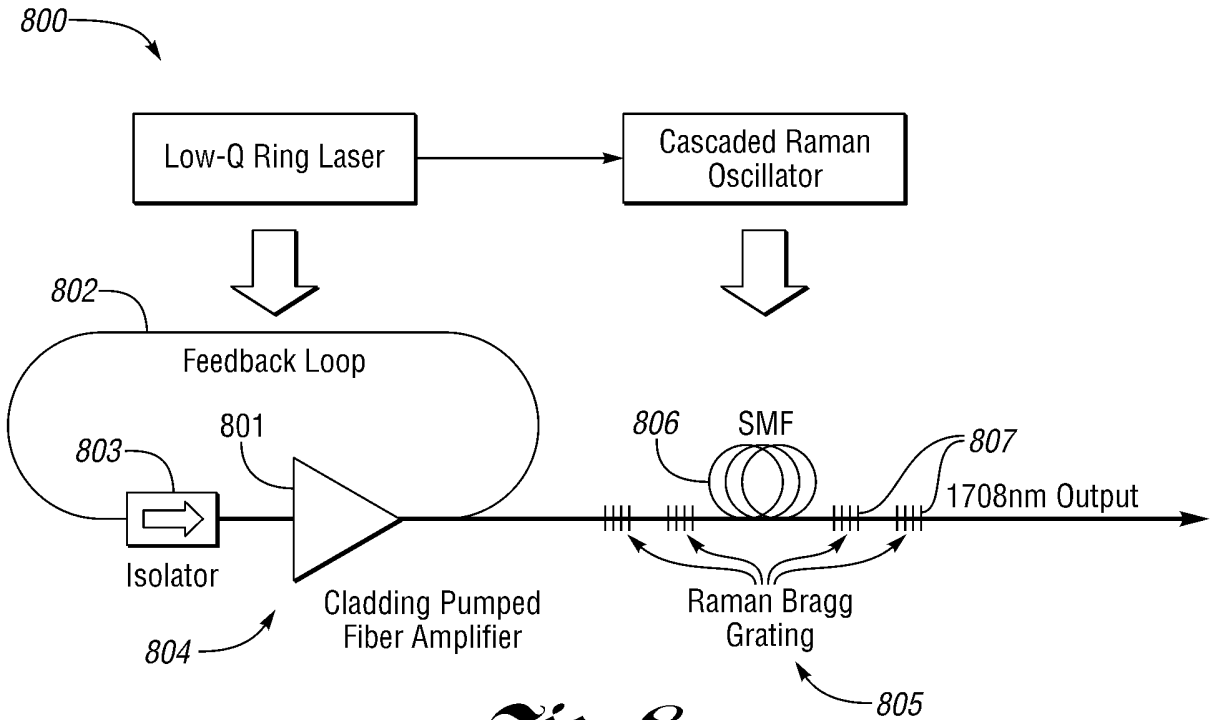
*Fig. 5*



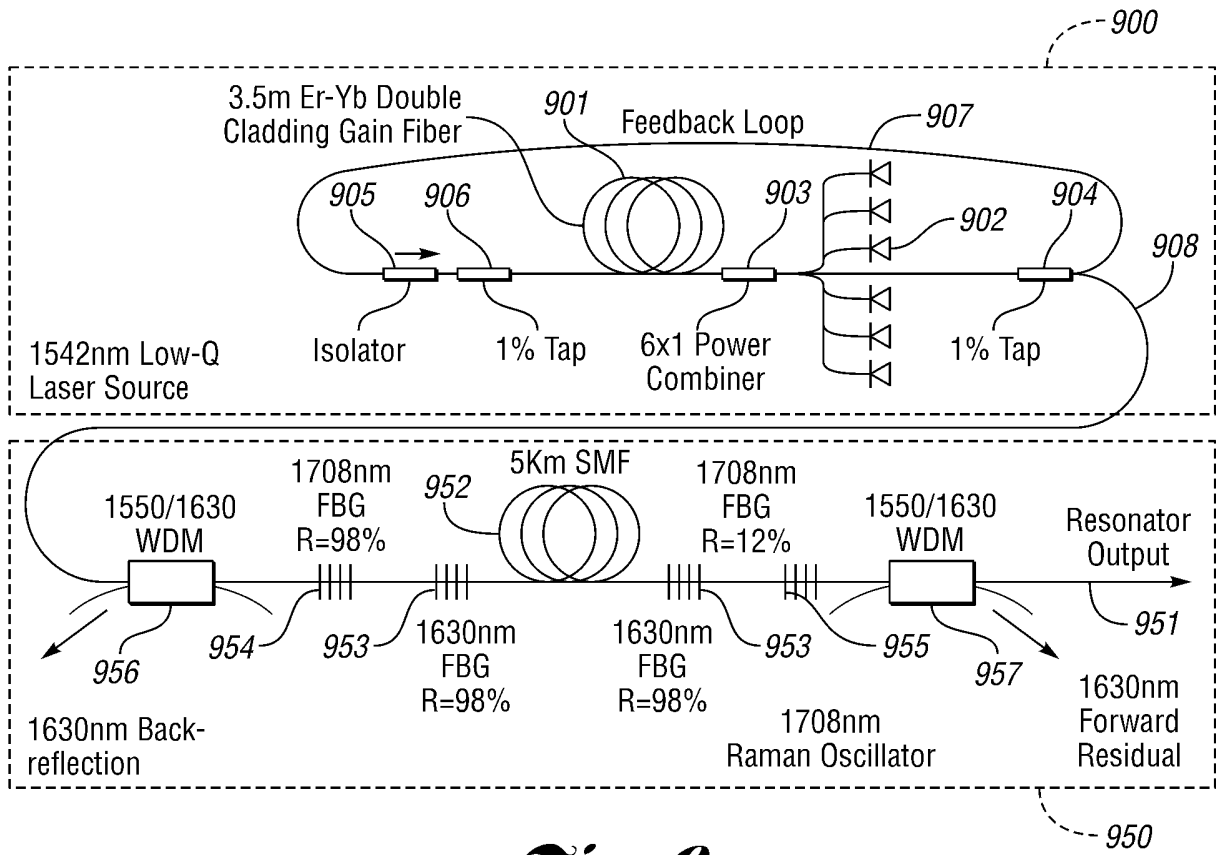
*Fig. 6*



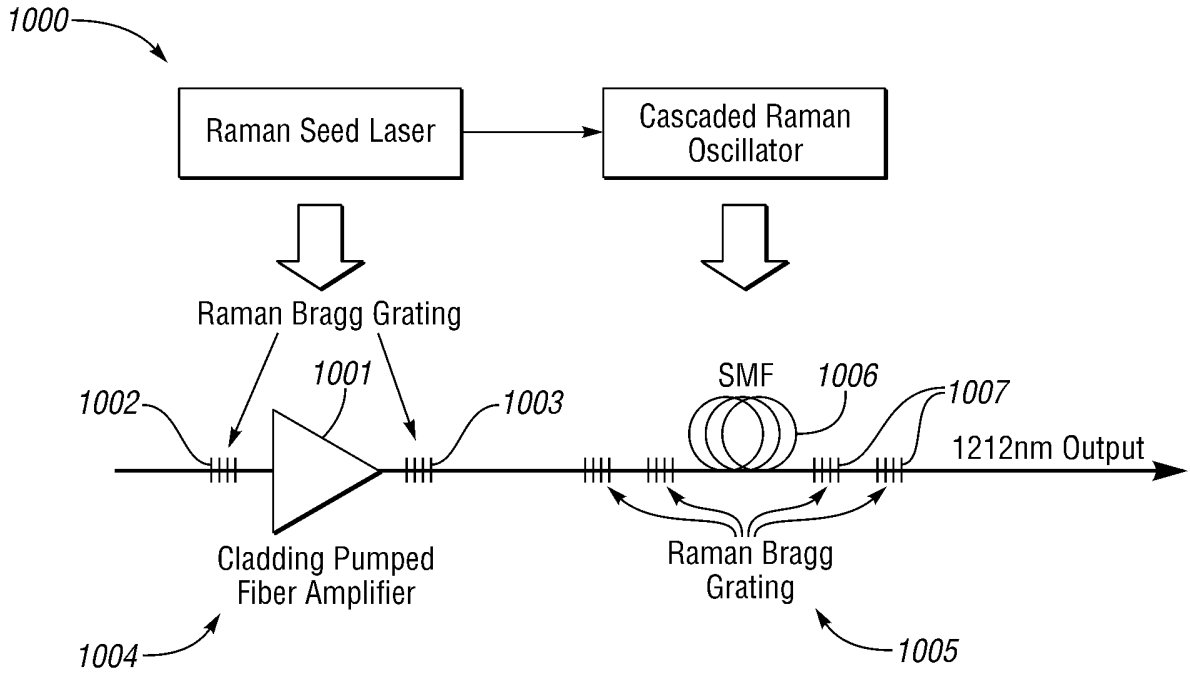
*Fig. 7*



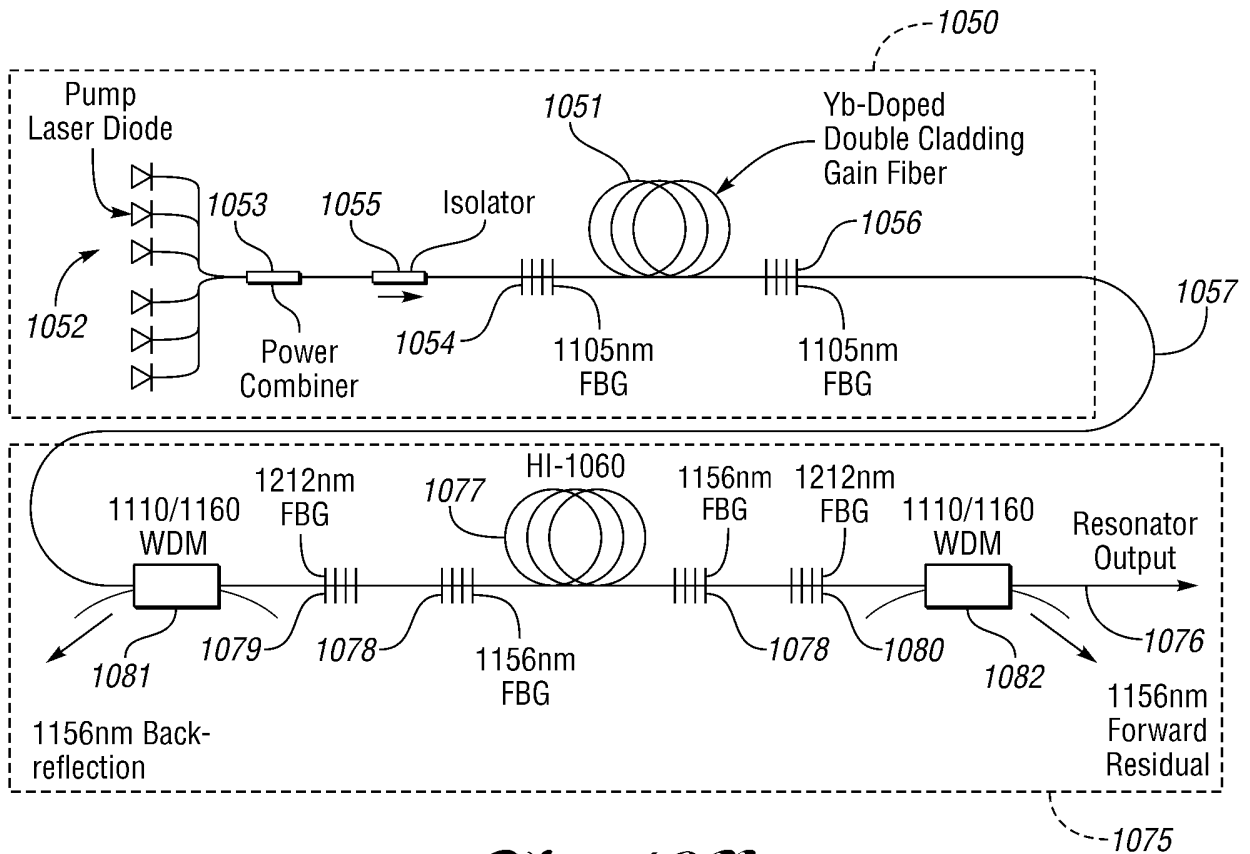
*Fig. 8*



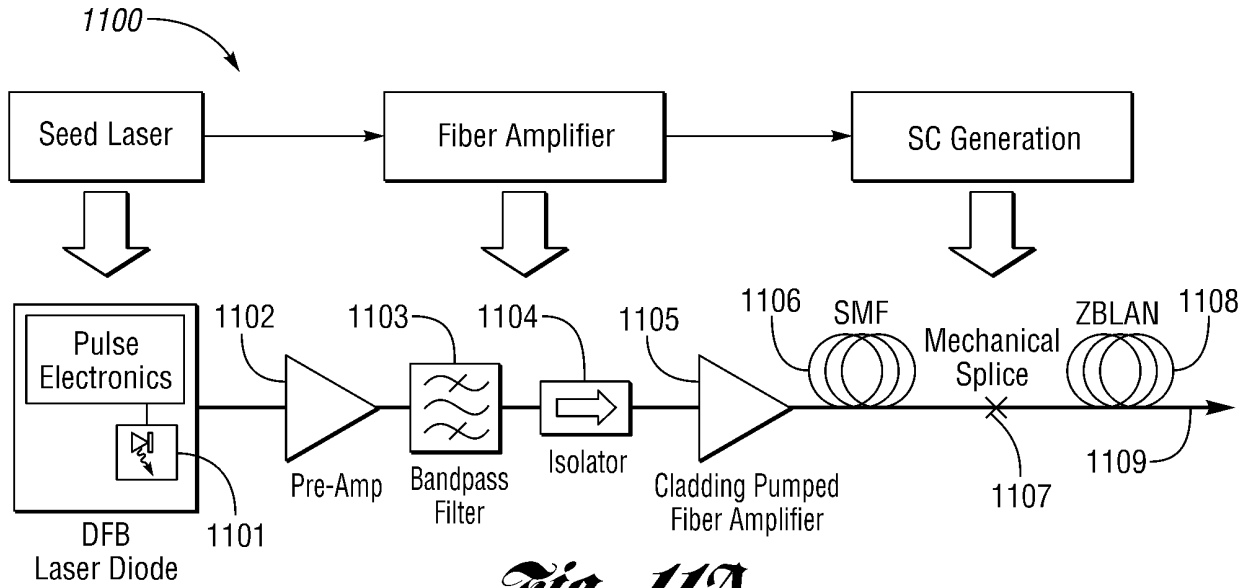
*Fig. 9*



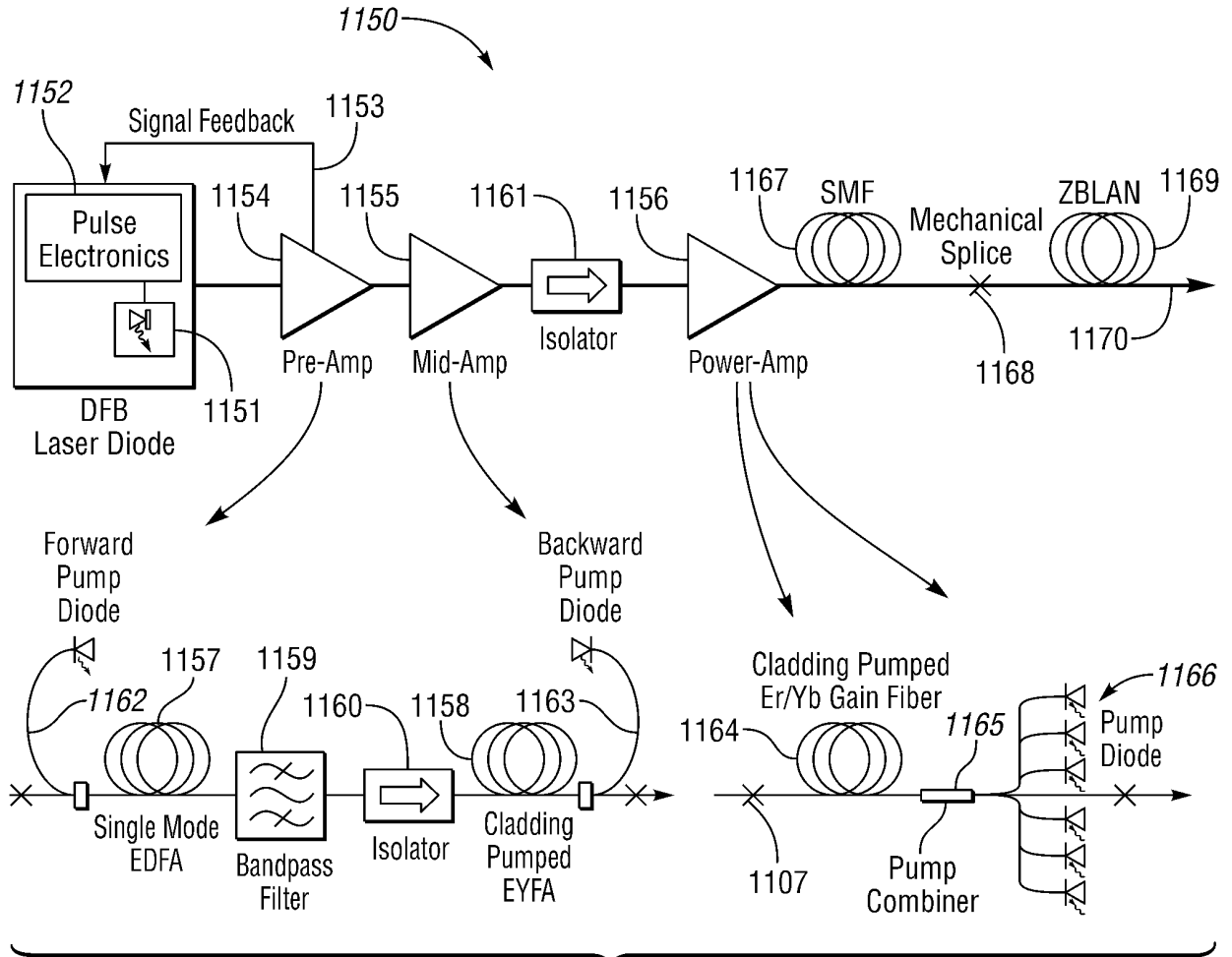
*Fig. 10A.*



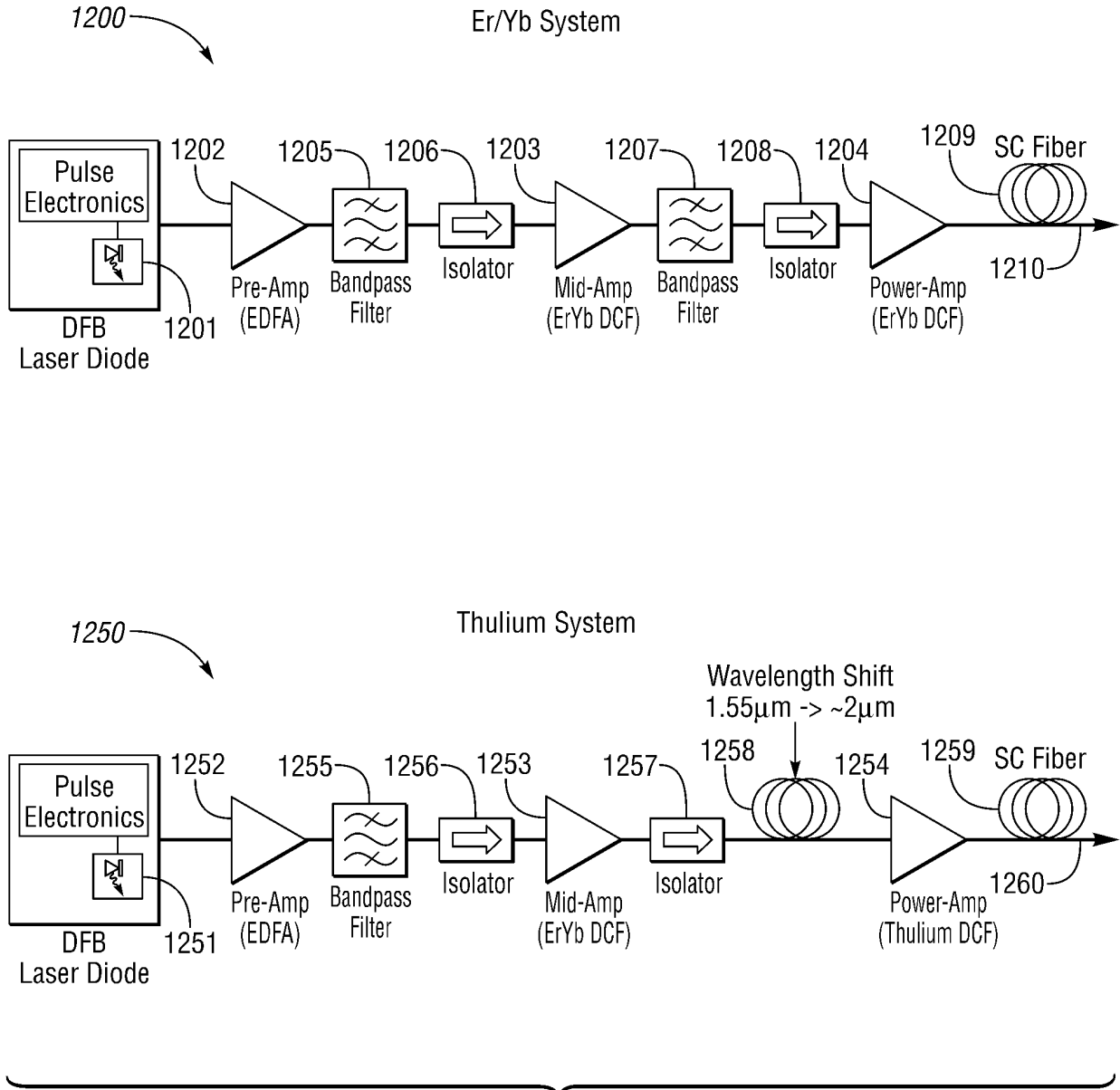
*Fig. 10B.*



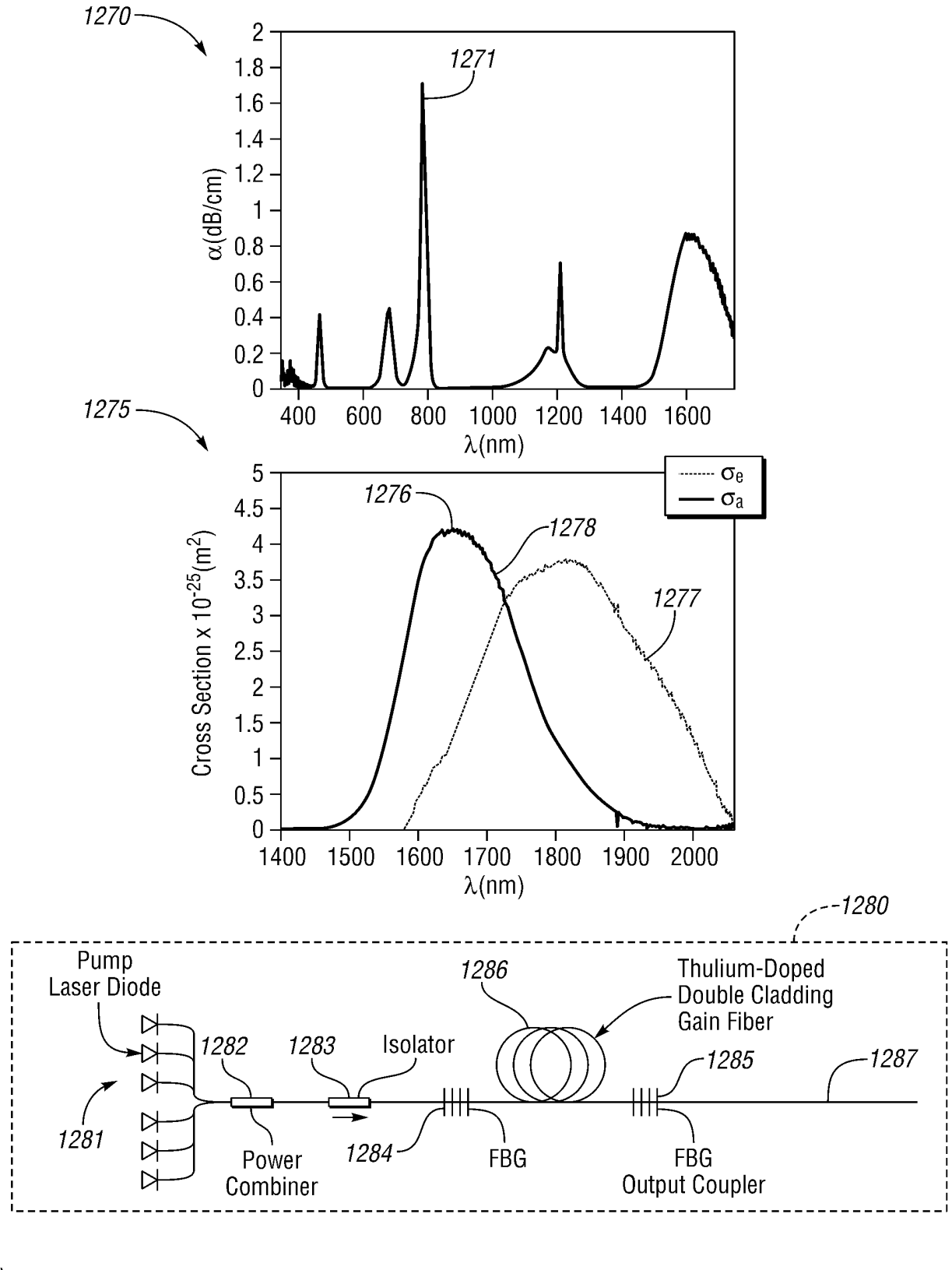
*Fig. 11A*



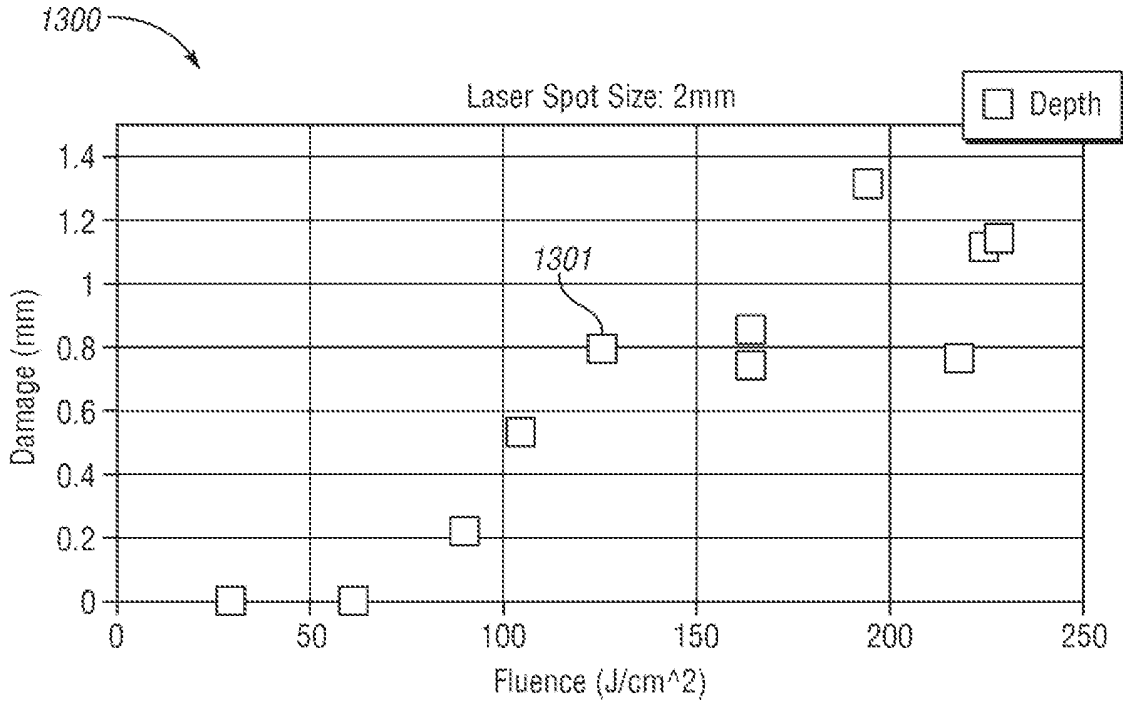
*Fig. 11B*



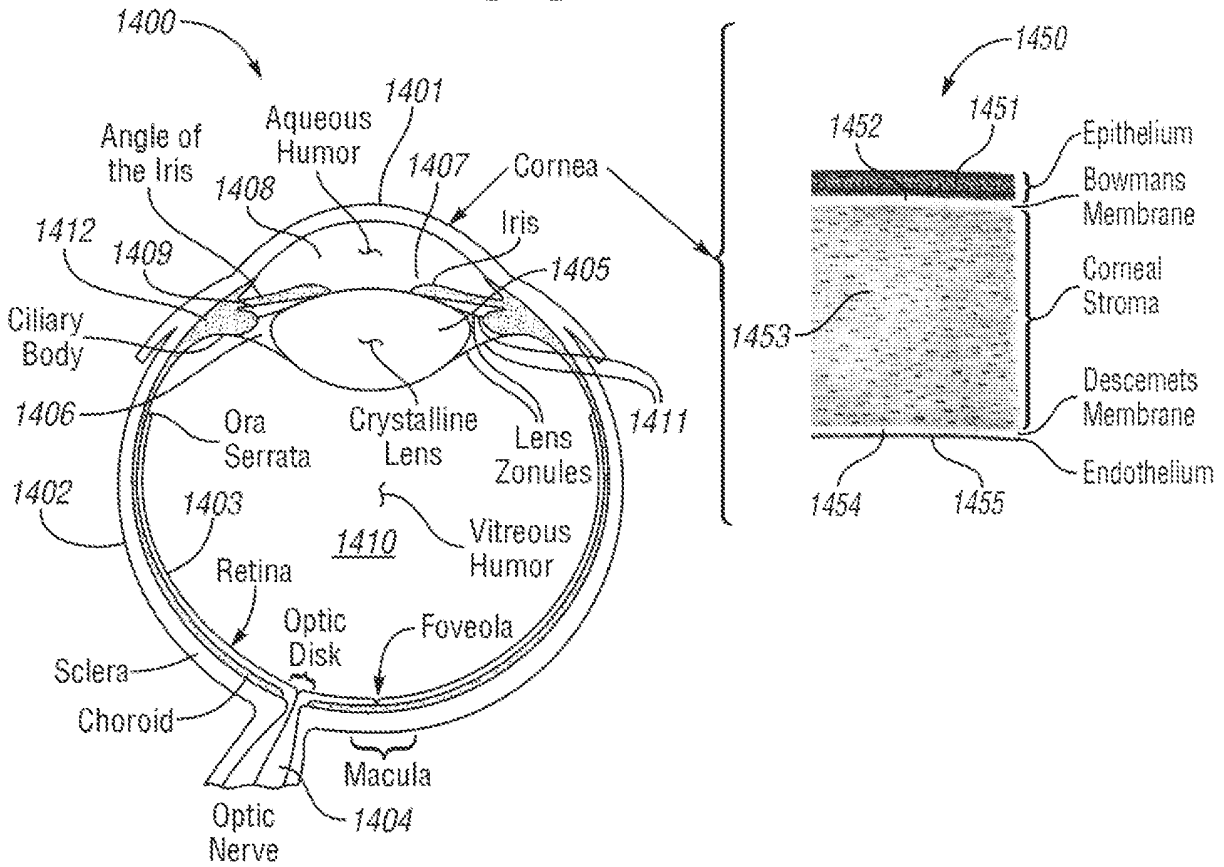
*Fig. 12A.*



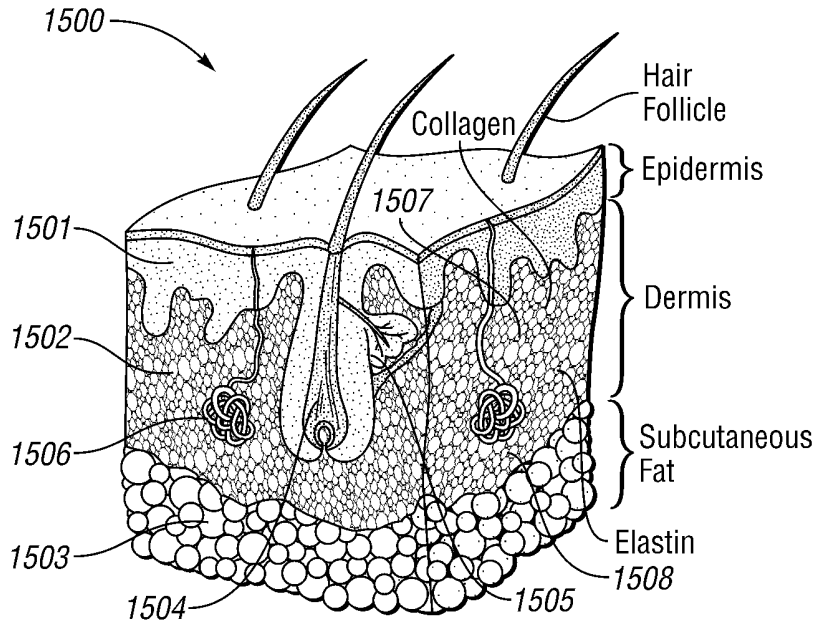
**Fig. 123**



*Fig. 13*

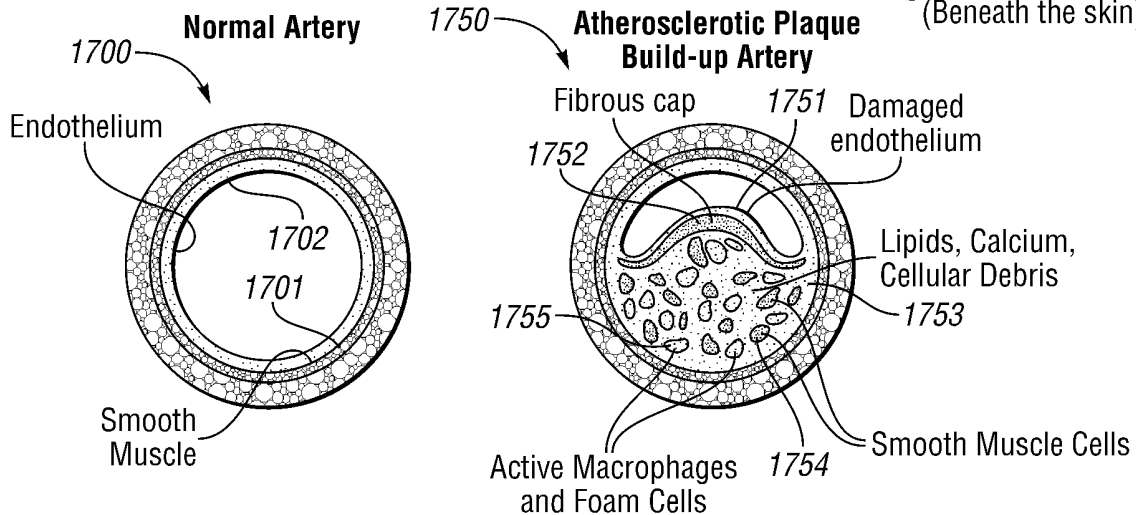
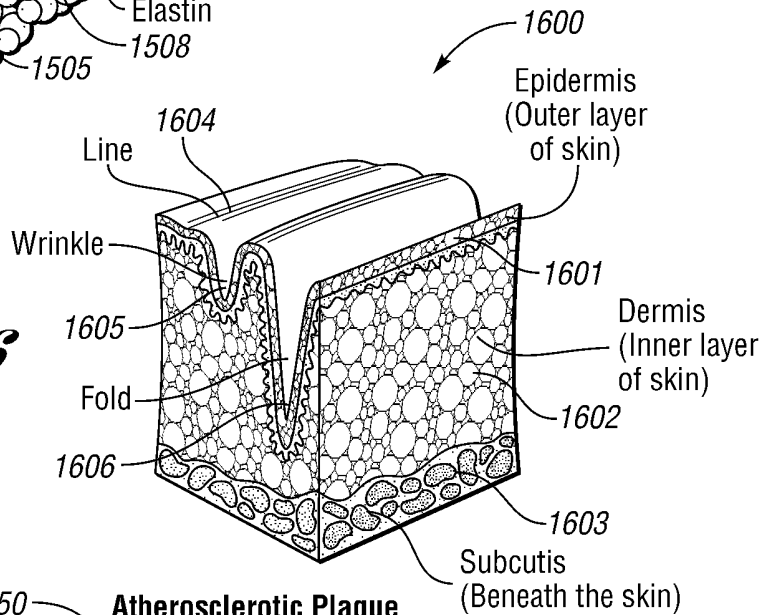


*Fig. 14*

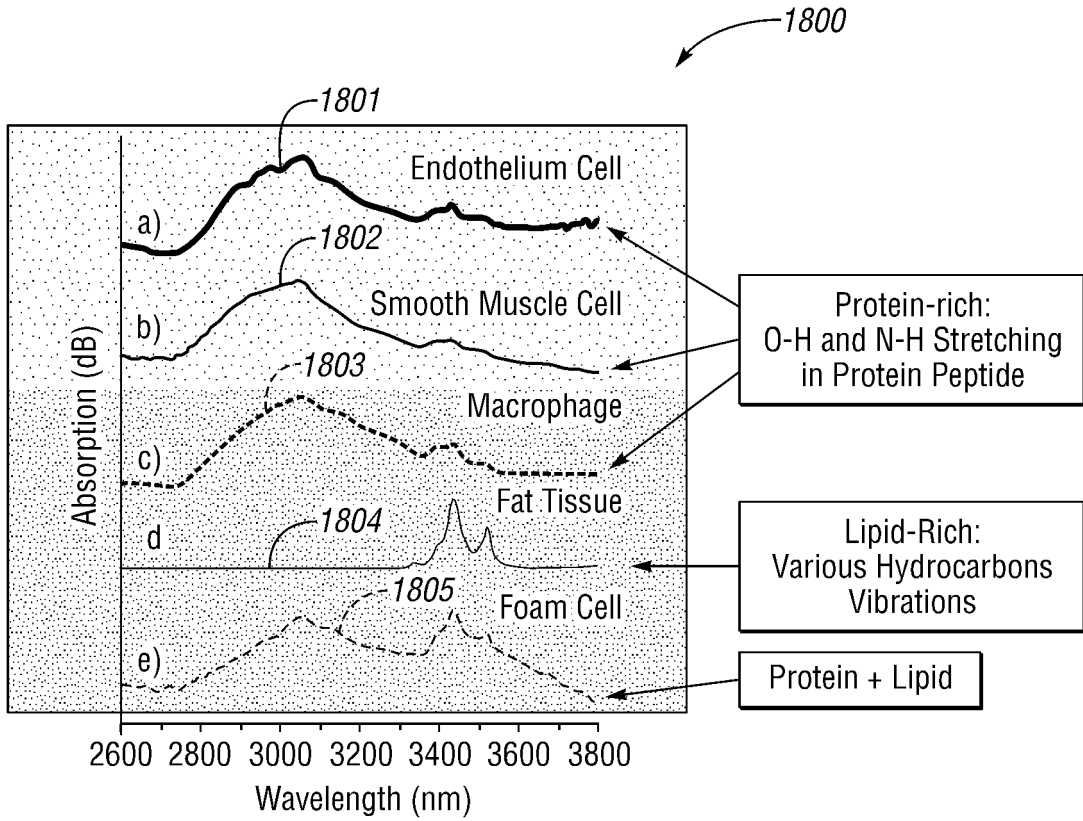


*Fig. 15*

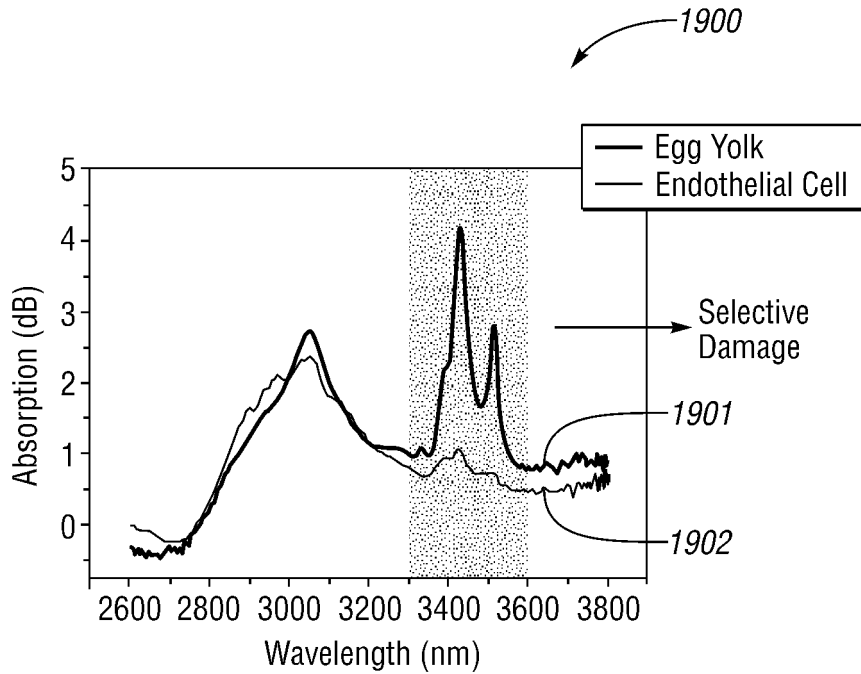
*Fig. 16*



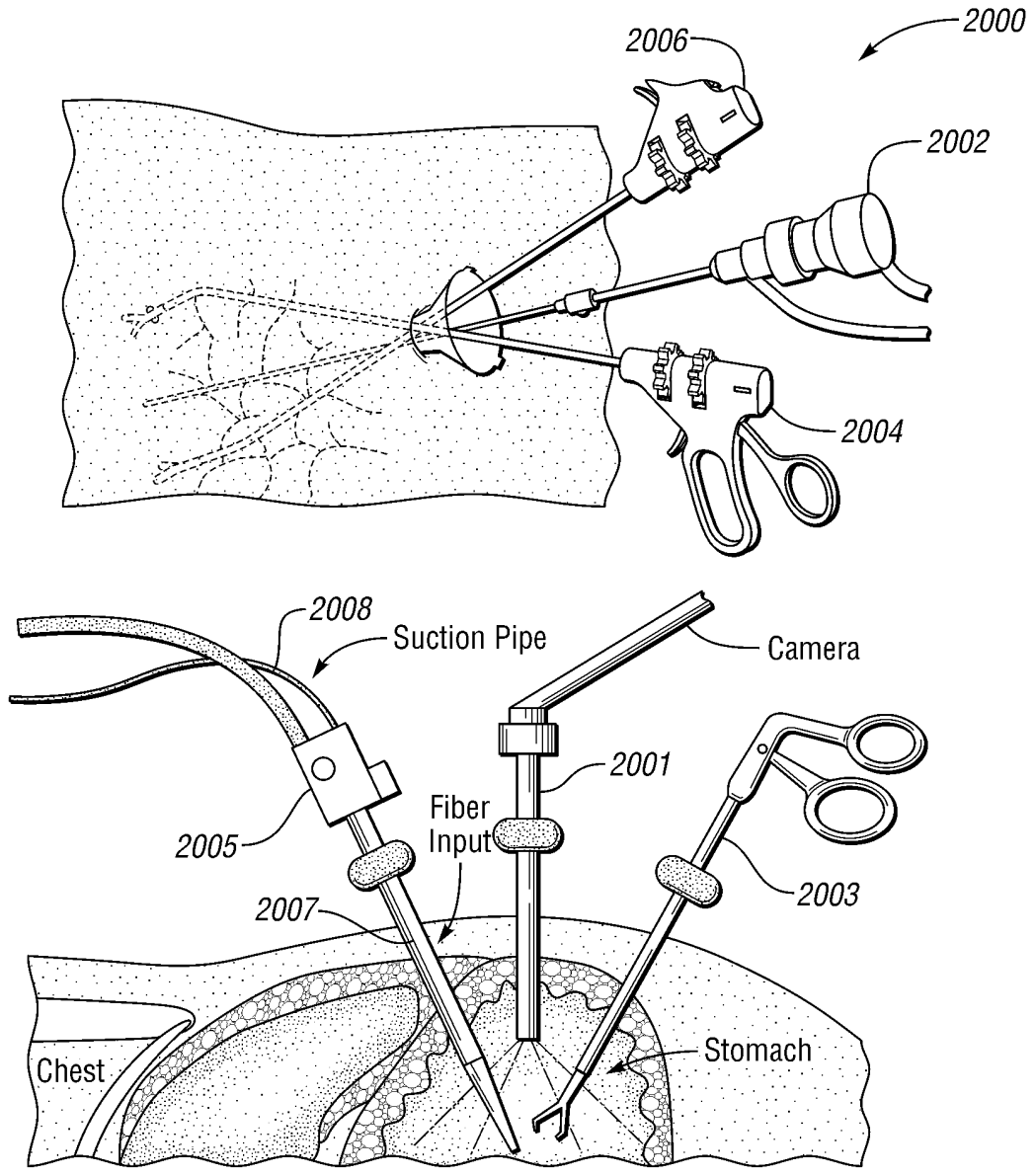
*Fig. 17*



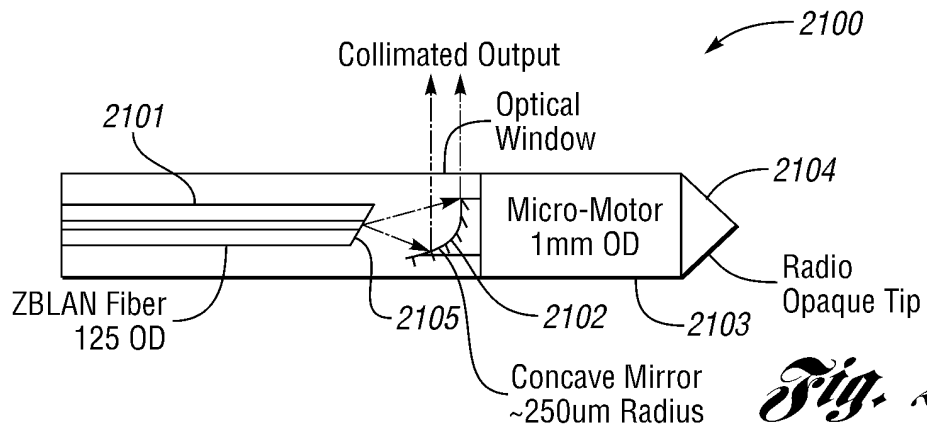
*Fig. 18*



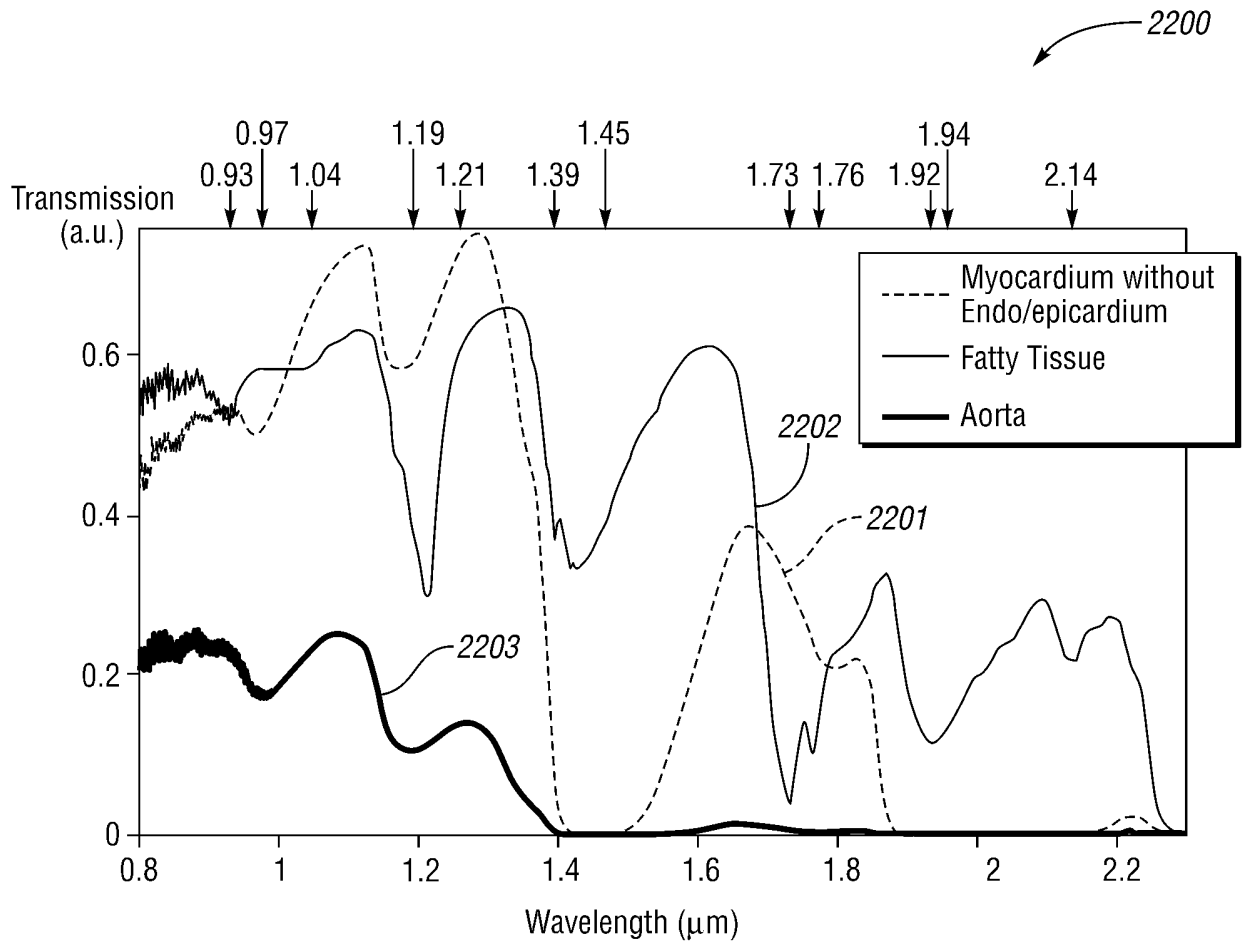
*Fig. 19*



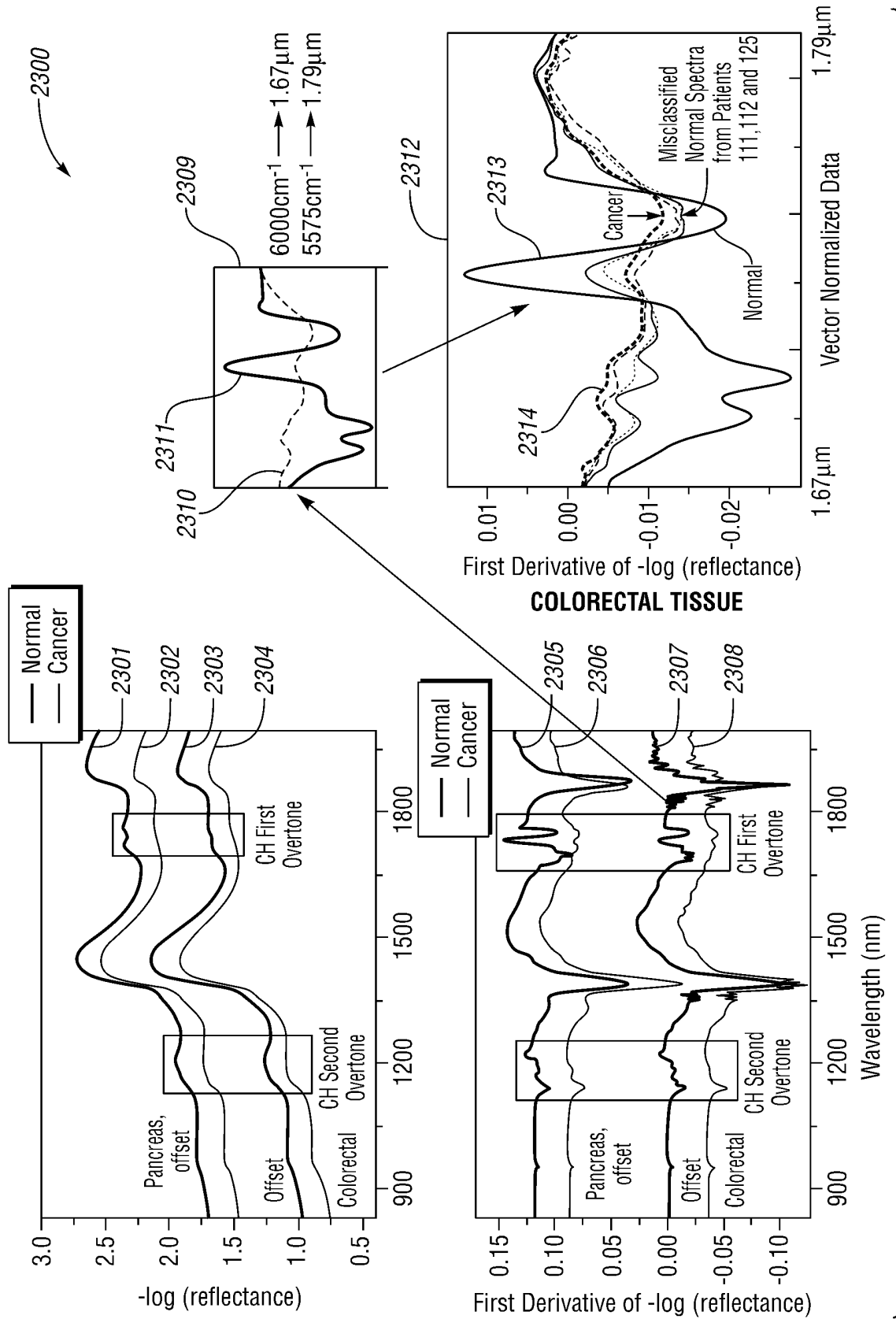
*Fig. 20*



*Fig. 21*



*Fig. 22*



*Fig. 23*

**REFERENCES CITED IN THE DESCRIPTION**

*This list of references cited by the applicant is for the reader's convenience only. It does not form part of the European patent document. Even though great care has been taken in compiling the references, errors or omissions cannot be excluded and the EPO disclaims all liability in this regard.*

**Patent documents cited in the description**

- US 2009028193 A [0002]
- US 20080015557 A [0002]
- US 5618284 A [0005]
- US 5779696 A [0005]
- US 6159205 A [0005]
- US 6605080 B [0005]
- US 6986764 B [0005]
- US 7060061 B [0005]
- US 7633673 B [0005]
- US 20090054879 A [0005]
- US 2008132886 A [0007]
- US 2008059793 A [0007]
- US 2008269735 A [0007]

专利名称(译)	用于选择性生物组织处理和光谱学的方法和系统中的光纤激光器和中红外光源		
公开(公告)号	<a href="#">EP2521505B1</a>	公开(公告)日	2017-09-06
申请号	EP2010798941	申请日	2010-12-30
[标]申请(专利权)人(译)	CHEETAH OMNI		
申请(专利权)人(译)	CHEETAH OMNI, LLC		
[标]发明人	ISLAM MOHAMMED N		
发明人	ISLAM, MOHAMMED N.		
IPC分类号	A61B18/20 A61B18/22 A61F9/008		
CPC分类号	A61B18/20 A61B2018/00464 A61B2018/2065 A61B2018/2244 A61F9/008 A61F9/00804 A61F9/00814 H01S3/0064 H01S3/0078 H01S3/0675 H01S3/06758 H01S3/094042 H01S3/1616 H01S3/1618 H01S3/302		
代理机构(译)	PARKER, 安杰		
优先权	61/335456 2010-01-07 US 61/335455 2010-01-07 US 61/335440 2010-01-07 US		
其他公开文献	EP2521505A2		
外部链接	<a href="#">Espacenet</a>		

摘要(译)

提供了一种用于选择性地处理患者体内的靶组织材料的激光方法和系统以及用于其中的光学导管组件。该系统包括用于产生输出激光束的激光子系统。该系统还包括导管组件，该导管组件包括至少一根光纤，该光纤具有连接到激光子系统的近端，用于沿着传播路径引导输出激光束。光束具有光学和时间特性以及预定的选定波长。导管组件的尺寸设计成延伸穿过患者的第一部分中的开口并延伸到患者体内的组织材料加工部位。导管组件包括光束传递和聚焦子系统，其具有可调焦距并设置在传播路径中接收输出激光束并基于距离传播路径上的预定点到目标组织材料的距离，将光束可调节地定位在设置在患者的第二部分内的目标组织材料上的至少一个聚焦点上。该部位的持续时间足以使激光能量被目标组织材料吸收并转换成热量以在目标组织材料中产生所需的物理变化，而不会对设置在第二部分内的相邻非目标材料造成不希望的变化。患者。靶组织材料的特征在于吸收系数。选择预定波长以实现进入患者的第二部分的穿透深度约为1毫米或更小更多。

