

(19)



(11)

EP 2 228 705 B1

(12)

EUROPEAN PATENT SPECIFICATION

(45) Date of publication and mention of the grant of the patent:
09.10.2013 Bulletin 2013/41

(51) Int Cl.:
G05G 1/445 ^(2008.04) **A61B 17/00** ^(2006.01)
G05G 9/02 ^(2006.01) **G05G 1/30** ^(2008.04)
G05G 1/42 ^(2008.04)

(21) Application number: **09161919.7**

(22) Date of filing: **04.06.2009**

(54) **Pedal input device with three rotational degrees of freedom**

Pedaleingabevorrichtung mit drei drehbaren Freiheitsgraden

Dispositif d'entrée à pédale avec trois degrés de liberté en rotation

(84) Designated Contracting States:
**AT BE BG CH CY CZ DE DK EE ES FI FR GB GR
HR HU IE IS IT LI LT LU LV MC MK MT NL NO PL
PT RO SE SI SK TR**

- **Bach, Du-Jin**
Gyeonggi-do (KR)
- **Im, Hye Won**
Gyeonggi-do (KR)
- **Kim, Young Woo**
Gyeonggi-do (KR)

(30) Priority: **12.03.2009 KR 20090021232**

(43) Date of publication of application:
15.09.2010 Bulletin 2010/37

(74) Representative: **Jenkins, Peter David**
Page White & Farrer
Bedford House
John Street
London WC1N 2BF (GB)

(73) Proprietor: **National Cancer Center**
Ilsandong-gu
Goyang-si, Gyeonggi-do (KR)

(56) References cited:
EP-A2- 0 570 765 WO-A1-2008/052321
US-A- 4 168 707

(72) Inventors:
• **Jo, Yung Ho**
Gyeonggi-do (KR)

EP 2 228 705 B1

Note: Within nine months of the publication of the mention of the grant of the European patent in the European Patent Bulletin, any person may give notice to the European Patent Office of opposition to that patent, in accordance with the Implementing Regulations. Notice of opposition shall not be deemed to have been filed until the opposition fee has been paid. (Art. 99(1) European Patent Convention).

Description

Field of the Invention

[0001] The present invention relates to a pedal input device with three rotational degrees of freedom and, more specifically, to a pedal input device for use in a mechanical, pressure- operated or electric manipulation apparatus operable with a minimized motion of the user's foot. With the pedal input device, a user can easily operate a drive member so as to make three- degree- of- freedom movement including translational movement, namely the combination of roll, pitch and z- axis translation and the combination of X- axis translation, y- axis translation and yaw, which is more difficult to perform with the foot than with the hand.

Background of the Invention

[0002] There have been already developed and used various kinds of devices which can be turned on or off with a foot switch and in which the work speed can be controlled with the foot switch. Such foot-switch-operated devices are essential when the user's hands need to be used for other tasks or when a user is not permitted to simultaneously use the feet and the hands for safety purposes.

[0003] For example, during the process of a modern surgical operation such as a laparoscopic operation or an ophthalmic operation, a foot switch is additionally operated by a surgeon to cause various kinds devices to perform different functions thereof.

[0004] Conventional foot switches are disclosed in U.S. Patent Nos. 6,132,313 and 5,787,760. The foot switches disclosed in these patents have two rotational degrees of freedom (pitch and yaw) and can make forward and backward movement. However, they are structurally complicated and bulky. In case of the foot switch of the '313 patent, it is necessary to use two different pivot elements because the axes of yaw and pitch are not aligned with each other. An additional space is also required to permit the forward and backward movement. In case of the foot switch of the '760 patent, linear guides have to be used in order to accurately control the movement. Also required is an additional space to permit the forward and backward movement.

[0005] WO 2008/052321 A1 discloses also a pedal input device comprising: a base plate ; a rotation center portion provided at the center of the base plate; a contacting plate rotatably and tiltably fitted to the rotation center portion.

[0006] A need has existed for a pedal input device capable of easily realizing three degrees of freedom, while enjoying a simplified structure and a reduced volume.

Disclosure of the Invention

[0007] In view of the above- noted problems, it is an

object of the present invention to provide a pedal input device with three rotational degrees of freedom in which three- degree- of- freedom movement occurs about a single rotation center, thereby accomplishing a simplified structure and a reduced size.

[0008] Another object of the present invention is to provide a pedal input device with three rotational degrees of freedom in which the translational movement of a drive member is caused by rotation of a pedal plate, thereby rendering the device operable with a minimized motion of the user's foot.

[0009] In accordance with an embodiment of the present invention, there is provided a pedal input device including: a base plate; a rotation center portion provided at the center of the base plate; a contacting plate rotatably and tiltably fitted to the rotation center portion, the contacting plate having a yaw switch contacting portion protruding downwards from lower surface of the contacting plate; a pedal plate carried by the contacting plate and foot- operated so as to cause a drive member to make three- degree- of- freedom rotational movement (roll, pitch and yaw), three- degree- of- freedom translational movement (x- axis or left- and- right translation, Y- axis or back- and- forth translation and Z- axis or up- and- down translation), the combination of two- degree- of- freedom translation and one- degree- of- freedom rotation (x- axis translation, y- axis translation and yaw), and the combination of two- degree- of- freedom rotation and one- degree- of- freedom translation (roll, pitch and z- axis translation) ; a pair of pitch switches installed on the base plate in an opposing relationship with each other so that the pitch switches can be alternately contacted to the contacting plate of the pedal plate; a pair of roll switches installed on the base plate in a perpendicular relationship to the pitch switches so that the roll switches can be alternately contacted to the contacting plate of the pedal plate; and a pair of yaw switches installed on the base plate in a spaced- apart relationship with each other so that the yaw switches can be alternately contacted to the yaw switch contacting portion as the pedal plate rotates.

[0010] Preferably, the contacting plate is fixedly secured to the pedal plate so that the pedal plate and the contacting plate can move together.

[0011] It is preferred that the rotation center portion includes a ball race provided at the center of the base plate and a ball joint attached to the contacting plate, the ball joint being coupled with the ball race for rotational and pivotal movement relative to the ball race.

[0012] Further, the rotation center portion may include a universal joint installed at the center of the base plate for making two- degree- of- freedom rotation (roll and pitch) and a thrust bearing coupled with the universal joint for making one- degree- of- freedom rotation (yaw), the thrust bearing being attached to the contacting plate.

[0013] Preferably, the base plate includes a peripheral edge portion, a support rim portion extending along the peripheral edge portion and one or more return spring

portions arranged along the support rim portion in a pre-determined interval to resiliently bias the pedal plate into an original position.

[0014] Further, the base plate includes a peripheral edge portion and a support rim portion extending along the peripheral edge portion, the contacting plate being connected to the support rim portion by a plurality of radially extending tension springs.

[0015] It is preferred that the pitch switches, the roll switches and the yaw switches are electric switches each having a contacting piece.

[0016] Preferably, the drive member is a manipulator for actuating a laparoscope used in a laparoscopic operation and a robotic surgery, the manipulator being configured to make three- degree- of- freedom movement including roll, pitch and z- axis translation.

[0017] With the present pedal input device with three rotational degrees of freedom, the three- degree- of- freedom movement occurs about a single rotation center, which makes it possible to accomplish a simplified structure and a reduced size. Furthermore, the translational movement of a drive member is caused by rotation of a pedal plate, which makes it possible to minimize the motion of the user's foot.

Brief Description of the Drawings

[0018]

Fig. 1 is an exploded perspective view showing a pedal input device in accordance with one embodiment of the present invention.

Fig. 2 is a plan view for explaining the yaw movement performed by the pedal input device in accordance with one embodiment of the present invention.

Figs. 3 and 4 are cross sectional views for explaining the pitch and roll movement performed by the pedal input device in accordance with one embodiment of the present invention.

Detailed Description of the Preferred Embodiments

[0019] Hereinafter, one preferred embodiment of the present invention will be described with reference to the accompanying drawings. The following description is made for illustrative purposes to enable a person skilled in the art to carry out the invention with ease but is not intended to limit the scope of the invention.

[0020] Fig. 1 is an exploded perspective view showing a pedal input device in accordance with one embodiment of the present invention. Fig. 2 is a plan view for explaining the yaw movement performed by the pedal input device in accordance with one embodiment of the present invention. Figs. 3 and 4 are cross sectional views for explaining the pitch and roll movement performed by the pedal input device in accordance with one embodiment of the present invention.

[0021] As shown in Fig. 1, the pedal input device 100

with three rotational degrees of freedom includes a base plate 110, a rotation center portion 120 about which the roll, pitch and yaw movement is made, pitch, roll and yaw switches 140, 150 and 160 arranged on the base plate 110 for generating electric signals needed to operate a drive member 1, and a pedal plate 130 rotatably and tiltably fitted to the rotation center portion 120 and foot-operated to selectively contact the pitch, roll and yaw switches 140, 150 and 160.

[0022] The base plate 110 has a circular or polygonal shape and is provided with a flat bottom surface so that it can be placed on the floor. The base plate 110 is made of a metal or a synthetic resin. A rubber member may be attached to the bottom surface of the base plate 110 to enhance the frictional contact of the bottom surface with the floor.

[0023] The rotation center portion 120 is installed in the central area of the base plate 110. The rotation center portion 120 ensures that the roll, pitch and yaw movement of the pedal plate 130 is made on one center point. The rotation center portion 120 includes a ball race 122 having a concave groove at its center and a ball joint 124 having a ball portion coupled with the concave groove of the ball race 122. The ball portion makes rolling contact with the concave groove for pivotal and rotational movement.

[0024] As an alternative example not shown in the drawings, the rotation center portion 120 may include a universal joint installed at the center of the base plate 110 for making two- degree- of- freedom rotation (roll and pitch) and a thrust bearing coupled with the universal joint for making one- degree- of- freedom rotation (yaw) .

[0025] A disk-shaped contacting plate 132 is attached to the upper end of the ball joint 124 which is rotatably and tiltably fitted to the rotation center portion 120. The pedal plate 130 is brought into close contact with the upper surface of the contacting plate 132 so that the pedal plate 130 and the contacting plate 132 can move together about the rotation center portion 120.

[0026] The contacting plate 132 has a diameter suitable for allowing the contacting plate 132 to make contact with the pitch switches 140, the roll switches 150 and the yaw switches 160. The pedal plate 130 is touched and operated by the user's foot and may have the same area and contour as that of the base plate 110.

[0027] The pedal plate 130 and the contacting plate 132 may be fixed together by screws or other fastening means. Arrows or other indicia for indicating the pitch, roll and yaw movement may be provided on the upper surface of the pedal plate 130.

[0028] The pitch switches 140 are arranged on the base plate 110 substantially at twelve o'clock and six o'clock positions in Figs. 1 and 2 in a diametrically opposing relationship with each other. The pitch switches 140 include elastic contacting pieces 141 extending radially inwards. The contacting pieces 141 are electrically connected to the pitch switches 140 so that they can be contacted to the contacting plate 132 in an alternating manner.

[0029] The pitch switches 140 are electric units that cause the drive member 1 to make back- and- forth translational movement or pitch movement while the drive member 1 is kept stationary or moving. Although the drive member 1 taken as an example in the illustrated embodiment is a laparoscope manipulator, the present invention may apply to other mechanisms if they can make three-degree- of- freedom rotation (roll, pitch and yaw), three-degree- of- freedom translation (x- axis or left- and- right translation, Y- axis or back- and- forth translation and Z- axis or up- and- down translation), the combination of two- degree- of- freedom translation and one- degree- of- freedom rotation (x- axis translation, y- axis translation and yaw) and the combination of two- degree- of- freedom rotation and one- degree- of- freedom translation (roll, pitch and z- axis translation) . Although not shown in the drawings, it may be possible to employ a control unit for controlling electric signals for roll, pitch and yaw movement and a drive unit such as a cylinder or the like.

[0030] The roll switches 150 are arranged on the base plate 110 substantially at three o'clock and nine o'clock positions in Figs. 1 and 2 in a perpendicular relationship to the pitch switches 140. The roll switches 150 include elastic contacting pieces 151 extending radially inwards. The contacting pieces 151 are electrically connected to the roll switches 150 so that they can be contacted to the contacting plate 132 in an alternating manner.

[0031] The roll switches 150 are electric units that cause the drive member 1 to make left-and-right translational movement or roll movement while the drive member 1 is kept stationary or moving.

[0032] The yaw switches 160 are arranged on the base plate 110 substantially at one o'clock and eleven o'clock positions in Figs. 1 and 2 in an adjoining relationship with the pitch switch 140 arranged at the twelve o'clock position.

[0033] The yaw switches 160 include contacting pieces 161 provided on the opposing side surfaces thereof. The contacting plate 132 includes a yaw switch contacting portion 134 extending downwards from the lower surface of the contacting plate 132. The yaw switch contacting portion 134 is interposed between the contacting pieces 161 of the yaw switches 160 so that the contacting pieces 161 can make contact with the yaw switch contacting portion 134 in an alternating manner.

[0034] In other words, if the contacting plate 132 makes yaw movement out of a horizontal posture, the yaw switch contacting portion 134 is alternately contacted to one of the yaw switches 160, thus causing the drive member 1 to make up-and-down translational movement or yaw movement.

[0035] The base plate 110 includes an annular support rim portion 112 extending along the peripheral edge portion thereof and protruding upwards at a specified height. One or more return spring portions 114 are arranged along the support rim portion 112. Preferably, the return spring portions 114 are arranged in an interval of about 45 degrees. Each of the return spring portions 114 is

inserted in respective hole in the annular support rim portion 112 and includes a compression spring and a cap mounted thereon. The return spring portions 114 acts to return the pedal plate 130 to an original position at the end of pitch and roll movement.

[0036] Tension springs 116 are radially retained between the contacting plate 132 and the support rim portion 112 in order to return the pedal plate 130 and the contacting plate 132 to an original position at the end of yaw movement, i.e., horizontal rotation. The tension springs 116 are circumferentially spaced apart from one another in an interval of about 90 degrees. In addition, the support rim portion 112 may have a cutout for engagement with a connector of the drive member 1.

[0037] The pedal input device with three rotational degrees of freedom operates as follows.

[0038] Referring to Figs. 2 through 4, during the course of, e.g., a laparoscopic operation or a robotic surgery, a doctor operates a laparoscope with the pedal input device 100 while holding operation instruments with the hands.

[0039] As shown in Fig. 3, the pedal plate 130 is kept horizontal by the return spring portions 114 when the user's foot is not placed on the pedal plate 130. At this time, the contacting plate 132 remains in contact with the contacting pieces 141 and 151 of the pitch switches 140 and the roll switches 150, in which each switch is turned off.

[0040] When there is a need to operate the drive member 1, e.g., a laparoscope manipulator, capable of making three- degree- of- freedom movement, namely the combination of roll, pitch and z- axis translation, the user operates the drive member 1 by placing his or her foot on the pedal plate 130.

[0041] In order to cause the drive member 1 to make linear up-and-down translational movement, the user rotates the pedal plate 130 to left or right about the rotation center portion 120 in a horizontal posture. As the pedal plate 130 rotates, the yaw switch contacting portion 134 of the contacting plate 132 presses the contacting piece 161 of one of the yaw switches 160, thereby turning on the corresponding one of the yaw switches 160. Thereafter, the pedal plate 130 is returned back to an original position under the biasing force of the tension spring 116 retained between the contacting plate 132 and the support rim portion 112.

[0042] If it is necessary to cause the drive member 1 to make pitch movement during its translational movement or stoppage, the pedal plate 130 is tilted forwards or backwards about the rotation center portion 120. In response, the contacting plate 132 presses the contacting piece 141 of one of the pitch switches 140, thereby turning on the corresponding one of the pitch switches 140. At this time, the return spring portions 114 near the pressed pitch switch 140 are compressed and then released to keep the pedal plate 130 horizontal.

[0043] Similarly, if it is necessary to cause the drive member 1 to make roll movement during its translational

movement or stoppage, the pedal plate 130 is tilted to left or right about the rotation center portion 120. In response, the contacting plate 132 presses the contacting piece 151 of one of the roll switches 150, thereby turning on the corresponding one of the roll switches 150. At this time, the return spring portions 114 near the pressed roll switch 150 are compressed and then released to keep the pedal plate 130 horizontal.

[0044] The translation, pitch and roll movement of the drive member 1 is repeatedly and continuously made as the pedal plate 130 is operated by the user in the above-noted manner.

[0045] Although the combination of two-degree-of-freedom rotational movement and one-degree-of-freedom translational movement (roll, pitch and z-axis translation) has been described above, the present invention is not limited thereto. By operating the pedal plate 130 about the rotation center portion 120 with three rotational degrees of freedom, it is possible for the drive member 1 to perform three-degree-of-freedom rotational movement (roll, pitch and yaw), three-degree-of-freedom translational movement (x-axis or left-and-right translation, Y-axis or back-and-forth translation and Z-axis or up-and-down translation), and the combination of two-degree-of-freedom translation and one-degree-of-freedom rotation (x-axis translation, y-axis translation and yaw) .

[0046] With the present pedal input device described above, the three-degree-of-freedom rotation movement occurs about a single rotation center, which makes it possible to accomplish a simplified structure and a reduced size. Furthermore, the translational movement of a drive member is caused by rotation of a pedal plate, which makes it possible to minimize the motion of the user's foot.

[0047] While one preferred embodiment of the present invention has been described hereinabove, the present invention is not limited thereto. It will be apparent to those skilled in the art that many different changes and modifications may be made without departing from the scope of the invention defined in the claims.

Claims

1. A pedal input device comprising:

- a base plate (110);
- a rotation center portion (120) provided at the center of the base plate;
- a contacting plate (132) rotatably and tiltably fitted to the rotation center portion, the contacting plate having a yaw switch (134) contacting portion protruding downwards from lower surface of the contacting plate;
- a pedal plate (130) carried by the contacting plate and foot-operated causing a drive member (1) to make three-degree-of-freedom rotational

movement, roll, pitch and yaw, three-degree-of-freedom translational movement, x-axis or left-and-right translation, Y-axis or back-and-forth translation and Z-axis or up-and-down translation, the combination of two-degree-of-freedom translation and one-degree-of-freedom rotation, x-axis translation, y-axis translation and yaw, and the combination of two-degree-of-freedom rotation and one-degree-of-freedom translation, roll, pitch and z-axis translation;

a pair of pitch switches (140) installed on the base plate in an opposing relationship with each other so that the pitch switches can be alternately contacted to the contacting plate of the pedal plate;

a pair of roll switches (150) installed on the base plate in a perpendicular relationship to the pitch switches so that the roll switches can be alternately contacted to the contacting plate of the pedal plate; and

a pair of yaw switches (160) installed on the base plate in a spaced-apart relationship with each other so that the yaw switches can be alternately contacted to the yaw switch contacting portion as the pedal plate rotates.

2. The pedal input device of claim 1, wherein the contacting plate is fixedly secured to the pedal plate so that the pedal plate and the contacting plate can move together.
3. The pedal input device of claim 1, wherein the rotation center portion includes a ball race provided at the center of the base plate and a ball joint attached to the contacting plate, the ball joint being coupled with the ball race for rotational and pivotal movement relative to the ball race.
4. The pedal input device of claim 1, wherein the rotation center portion includes a universal joint installed at the center of the base plate for making two-degree-of-freedom rotation (roll and pitch) and a thrust bearing coupled with the universal joint for making one-degree-of-freedom rotation (yaw), the thrust bearing being attached to the contacting plate.
5. The pedal input device of claim 1, wherein the base plate includes a peripheral edge portion, a support rim portion extending along the peripheral edge portion and one or more return spring portions arranged along the support rim portion in a predetermined interval to resiliently bias the pedal plate into an original position.
6. The pedal input device of claim 1, wherein the base plate includes a peripheral edge portion and a support rim portion extending along the peripheral edge

portion, the contacting plate being connected to the support rim portion by a plurality of radially extending tension springs.

7. The pedal input device of claim 1, wherein the pitch switches, the roll switches and the yaw switches are electric switches each having a contacting piece.
8. The pedal input device of claim 1, wherein the drive member is a manipulator for actuating a laparoscope used in a laparoscopic operation and a robotic surgery, the manipulator being configured to make three- degree- of- freedom movement including roll, pitch and z- axis translation.

Patentansprüche

1. Ein Pedal-Eingabegerät, bestehend aus:

einer Grundplatte (110);
 einem Drehzentrumsbereich (120) in der Mitte der Grundplatte;
 einer am Drehzentrumsbereich befestigten dreh- und kippbaren Kontaktplatte (132), die mit einem Gierschalter- (134) Kontaktbereich versehen ist, der von der unteren Fläche der Kontaktplatte nach unten vorsteht;
 einer von der Kontaktplatte getragenen, fußbetätigten Pedalplatte (130), die verursacht, dass ein Antriebsglied (1) die folgenden Bewegungen ausführt: eine Drehbewegung mit drei Freiheitsgraden, Roll, Nick und Gier, eine translatorische Bewegung mit drei Freiheitsgraden, X- Achsen- Translation bzw. Translation links und rechts, Y- Achsen- Translation bzw. Translation zurück und vorwärts und Z- Achsen- Translation bzw. Translation nach oben und nach unten, die Kombination der Translation mit zwei Freiheitsgraden und der Drehung mit einem Freiheitsgrad, X- Achsen- Translation, Y- Achsen- Translation und Gierung, sowie die Kombination von Drehung mit zwei Freiheitsgraden und Translation mit einem Freiheitsgrad, Roll-, Nick- und Z- Achsen- Translation;
 einem Paar Neigungsschalter (140), die in einer gegensätzlichen Beziehung zueinander auf der Grundplatte installiert sind, damit die Neigungsschalter abwechselnd mit der Kontaktplatte der Pedalplatte einen Kontakt herstellen können;
 einem Paar Roll-Schalter (150), die senkrecht zu den Neigungsschaltern auf der Grundplatte installiert sind, damit die Roll-Schalter abwechselnd mit der Kontaktplatte der Pedalplatte einen Kontakt herstellen können; und
 einem Paar Gierschalter (160), die so voneinander entfernt auf der Grundplatte installiert sind, dass die Gierschalter abwechselnd einen

Kontakt mit dem Gierschalter-Kontaktabschnitt herstellen können, während sich die Pedalplatte dreht.

- 5 2. Das Pedal-Eingabegerät nach Anspruch 1, worin die Kontaktplatte an der Pedalplatte fest gesichert ist, damit sich die Pedalplatte und die Kontaktplatte gemeinsam bewegen können.
- 10 3. Das Pedal-Eingabegerät nach Anspruch 1, worin der Drehzentrumsbereich einen Kugelkäfig in der Mitte der Grundplatte und ein an der Kontaktplatte angebautes Kugelgelenk umfasst; das Kugelgelenk ist zur Ausführung von Drehbewegungen und Drehverschiebungen in Bezug auf den Kugelkäfig mit dem Kugelkäfig gekoppelt.
- 15 4. Das Pedal-Eingabegerät nach Anspruch 1, worin der Drehzentrumsbereich ein in der Mitte der Grundplatte installiertes Kardangelenke zur Ausführung einer Drehung mit zwei Freiheitsgraden (Roll und Nick) sowie ein mit dem Kardangelenke gekoppeltes, an der Kontaktplatte befestigtes Axiallager zur Ausführung einer Drehung mit einem Freiheitsgrad (Gier) umfasst.
- 20 5. Das Pedal-Eingabegerät nach Anspruch 1, worin die Grundplatte Folgendes umfasst: einen peripheren Kantenbereich, einen entlang des peripheren Kantenbereiches führenden Tragerahmenbereich und einen oder mehrere Rückholfederbereiche entlang des Tragerahmenbereiches, die in einem vorbestimmten Abstand so angeordnet sind, dass sie die Pedalplatte in einer ursprünglichen Position elastisch vorspannen.
- 25 6. Das Pedal-Eingabegerät nach Anspruch 1, worin die Grundplatte einen peripheren Kantenbereich und einen Tragerahmenbereich umfasst, der sich entlang des peripheren Kantenbereiches erstreckt, wobei die Kontaktplatte durch eine Vielzahl von sternförmig erweiterbaren Spannfedern mit dem Tragerahmenbereich verbunden ist.
- 30 7. Das Pedal-Eingabegerät nach Anspruch 1, worin es sich bei den Neigungs-, Roll- und Gierschaltern um elektrische Schalter handelt, von denen jeder ein Kontaktelement hat.
- 35 8. Das Pedal-Eingabegerät nach Anspruch 1, worin das Antriebsglied ein Manipulator für die Betätigung eines in der laparoskopischen Chirurgie und in der roboter-assistierten Chirurgie verwendeten Laparoscops ist, wobei der Manipulator so konfiguriert wird, dass er eine Bewegung mit drei Freiheitsgraden ausführt, einschließlich Roll-, Nick- und Z-Achsen- Translation.
- 40
- 45
- 50
- 55

Revendications

1. Un dispositif d'entrée à pédale comprenant :

une plaque de base (110) ;
 une partie centrale de rotation (120) pourvue au centre de la plaque de base ;
 une plaque de contact (132) fixée de manière rotative et inclinable à la partie centrale de rotation, la plaque de contact possédant une partie de contact d'interrupteur de lacet (134) faisant saillie vers le bas depuis la surface inférieure de la plaque de contact ;
 un patin de pédale (130) porté par la plaque de contact et commandé au pied amenant un élément d'entraînement (1) à effectuer un mouvement de rotation de trois degrés de liberté, roulis, tangage et lacet, un mouvement de translation de trois degrés de liberté, axe des x ou translation gauche et droite, axe des y ou translation d'avance et de recul et axe des z ou translation montante et descendante, la combinaison de translation de deux degrés de liberté et de rotation d'un degré de liberté, translation d'axe des x, translation d'axe des y et lacet, et la combinaison de rotation de deux degrés de liberté et translation d'un degré de liberté, roulis, tangage et translation d'axe des z ;
 une paire d'interrupteurs de tangage (140) installés sur la plaque de base à l'opposé l'un par rapport à l'autre de façon à ce que les interrupteurs de tangage puissent établir un contact de manière alternative à la plaque de contact du patin de pédale ;
 une paire d'interrupteurs de roulis (150) installés sur la plaque de base perpendiculairement aux interrupteurs de tangage de façon à ce que les interrupteurs de roulis puissent établir un contact de manière alternative à la plaque de contact du patin de pédale ; et
 une paire d'interrupteurs de lacet (160) installés sur la plaque de base de manière espacée l'un par rapport à l'autre de façon à ce que les interrupteurs de lacet puissent établir un contact de manière alternative à la partie de contact d'interrupteur de lacet lors de la rotation du patin de pédale.

2. Le dispositif d'entrée à pédale de la revendication 1, dans lequel la plaque de contact est attachée de manière fixe au patin de pédale de façon à ce que le patin de pédale et la plaque de contact puissent se déplacer ensemble.

3. Le dispositif d'entrée à pédale de la revendication 1, dans lequel la partie centrale de rotation comprend un chemin de roulement à billes pourvu au centre de la plaque de base et un joint à rotule attaché à la

plaque de contact, le joint à rotule étant couplé avec le chemin de roulement à billes pour un mouvement par rotation et pivotement en relation au chemin de roulement à billes.

4. Le dispositif d'entrée à pédale de la revendication 1, dans lequel la partie centrale de rotation comprend un joint universel installé au centre de la plaque de base pour effectuer de la rotation de deux degrés de liberté (roulis et tangage) et un palier de butée couplé avec le joint universel pour effectuer de la rotation d'un degré de liberté (lacet), le palier de butée étant attaché à la plaque de contact.

5. Le dispositif d'entrée à pédale de la revendication 1, dans lequel la plaque de base inclut une partie de bord périphérique, une partie de jante de support s'étendant le long de la partie de bord périphérique et une ou plusieurs parties de ressorts de rappel agencés le long de la partie de jante de support dans un intervalle prédéterminé pour rappeler élastiquement le patin de pédale dans une position initiale.

6. Le dispositif d'entrée à pédale de la revendication 1, dans lequel la plaque de base inclut une partie de bord périphérique et une partie de jante de support s'étendant le long de la partie de bord périphérique, la plaque de contact étant connectée à la partie de jante de support par une pluralité de ressorts de tension s'étendant radialement.

7. Le dispositif d'entrée à pédale de la revendication 1, dans lequel les interrupteurs de tangage, les interrupteurs de roulis et les interrupteurs de lacet sont des interrupteurs électriques chacun possédant une pièce de contact.

8. Le dispositif d'entrée à pédale de la revendication 1, dans lequel l'élément d'entraînement est un manipulateur pour actionner un laparoscope utilisé dans une opération par laparoscopie et une chirurgie robotique, le manipulateur étant configuré pour effectuer un mouvement de trois degrés de liberté incluant roulis, tangage et translation d'axe des z.

FIG. 1

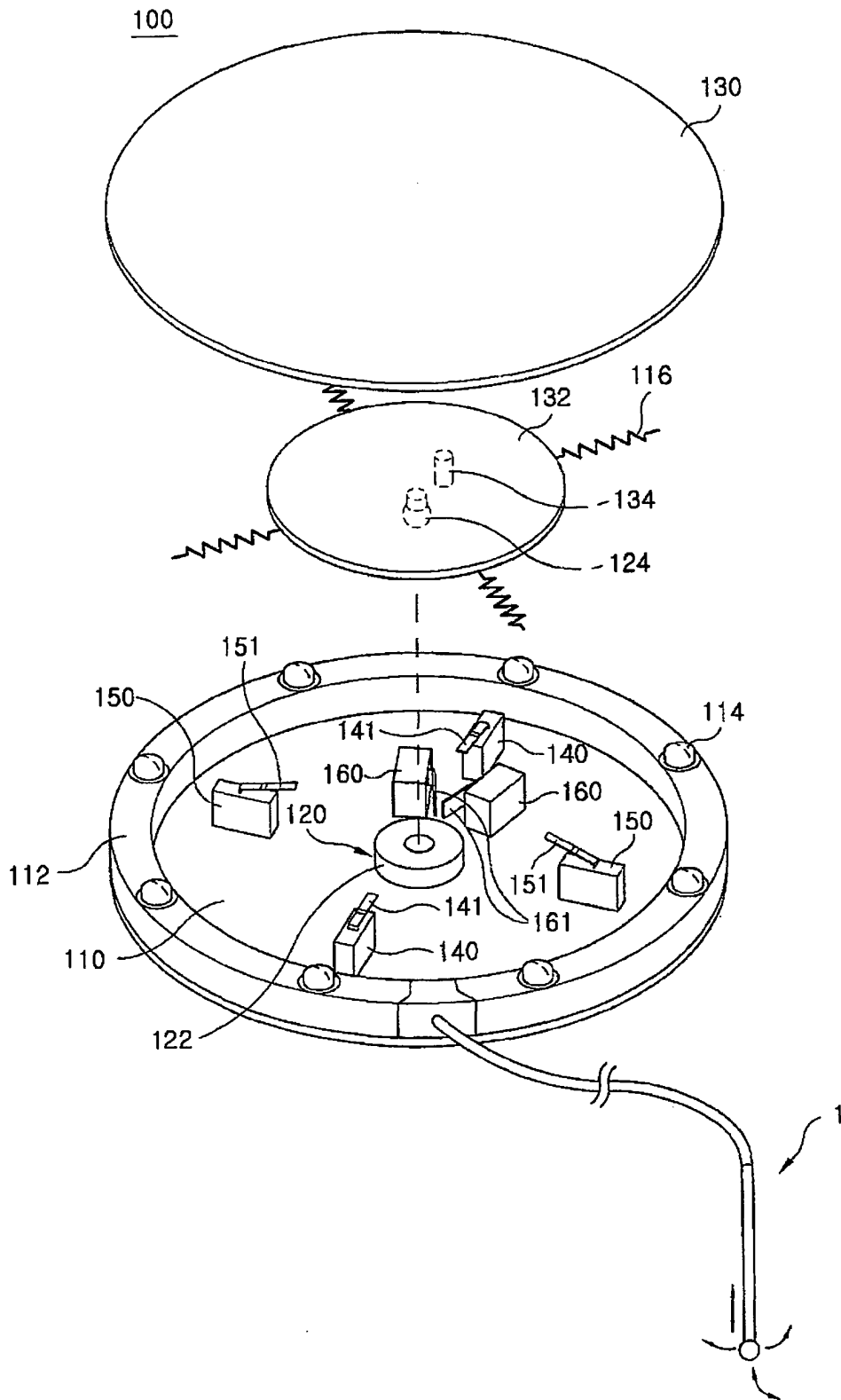

FIG. 2

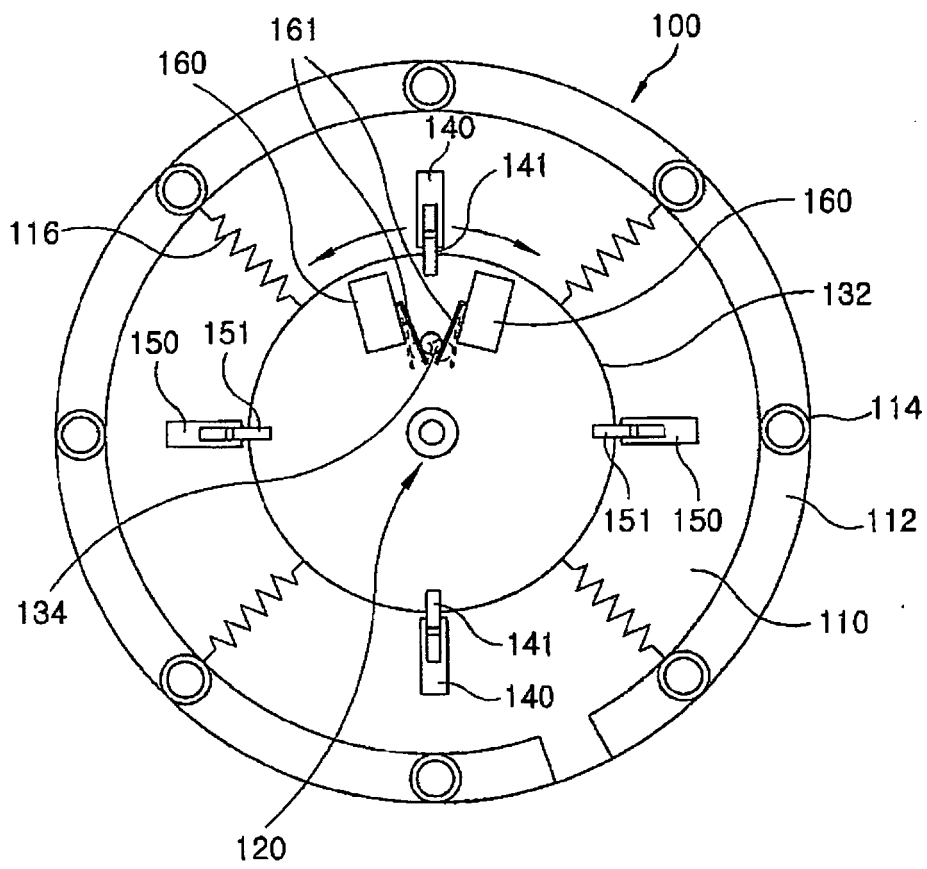

FIG. 3

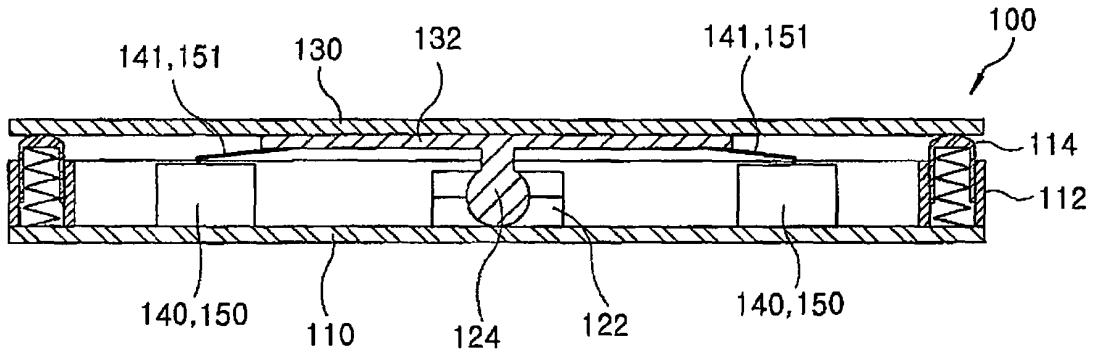
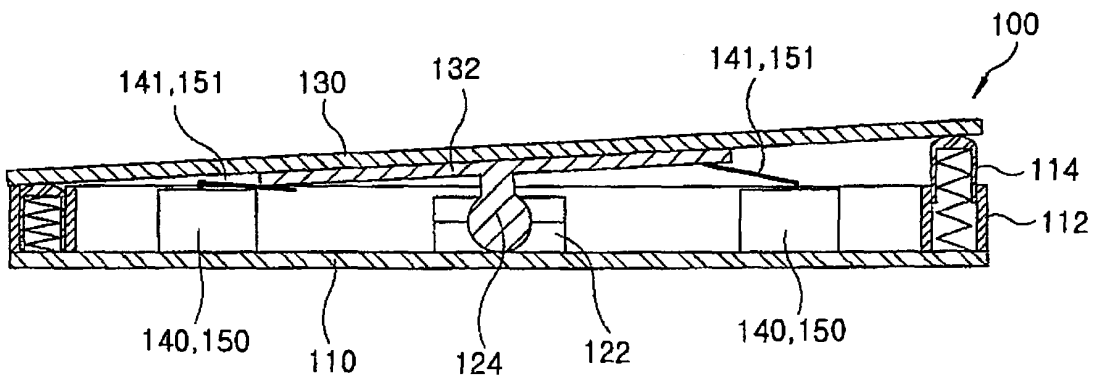

FIG. 4



REFERENCES CITED IN THE DESCRIPTION

This list of references cited by the applicant is for the reader's convenience only. It does not form part of the European patent document. Even though great care has been taken in compiling the references, errors or omissions cannot be excluded and the EPO disclaims all liability in this regard.

Patent documents cited in the description

- US 6132313 A [0004]
- US 5787760 A [0004]
- WO 2008052321 A1 [0005]

专利名称(译)	踏板输入装置具有三个旋转自由度		
公开(公告)号	EP2228705B1	公开(公告)日	2013-10-09
申请号	EP2009161919	申请日	2009-06-04
[标]申请(专利权)人(译)	NAT癌症CENT		
申请(专利权)人(译)	国家癌症中心		
当前申请(专利权)人(译)	国家癌症中心		
[标]发明人	JO YUNG HO BACH DU JIN IM HYE WON KIM YOUNG WOO		
发明人	JO, YUNG HO BACH, DU-JIN IM, HYE WON KIM, YOUNG WOO		
IPC分类号	G05G1/445 A61B17/00 G05G9/02 G05G1/30 G05G1/42		
CPC分类号	G05G1/445 A61B2017/00973 G05G1/30 Y10T74/20528		
代理机构(译)	JENKINS , PETER DAVID		
优先权	1020090021232 2009-03-12 KR		
其他公开文献	EP2228705A2 EP2228705A3		
外部链接	Espacenet		

摘要(译)

踏板输入装置 (100) 包括底板 (110) ; 旋转中心部分 (120) 设置在底板的中心; 接触板, 具有从接触板的下表面向下突出的偏航开关接触部分; 踏板 (130) , 由接触板承载并进行脚踏操作, 以使驱动构件进行三自由度运动; 一对变桨开关 (140) , 它们以相对的关系安装在底板 (110) 上; 一对滚动开关 (150) 以与俯仰开关 (140) 垂直的关系安装在底板 (110) 上, 使得滚动开关 (150) 可以交替地接触踏板的接触板; 一对偏航开关 (160) 以彼此间隔开的关系安装在基板上, 使得当踏板旋转时, 偏航开关 (160) 可以交替地接触偏航开关接触部分。

