



(11) **EP 2 083 706 B1**

(12) **EUROPEAN PATENT SPECIFICATION**

(45) Date of publication and mention of the grant of the patent:
01.02.2012 Bulletin 2012/05

(21) Application number: **07863898.8**

(22) Date of filing: **05.11.2007**

(51) Int Cl.:
A61B 17/04 (2006.01) A61B 17/28 (2006.01)

(86) International application number:
PCT/US2007/083617

(87) International publication number:
WO 2008/058067 (15.05.2008 Gazette 2008/20)

(54) **DELIVERING SUTURES**

NAHTFREISETZUNG

RÉALISATION DE SUTURES

(84) Designated Contracting States:
AT BE BG CH CY CZ DE DK EE ES FI FR GB GR HU IE IS IT LI LT LU LV MC MT NL PL PT RO SE SI SK TR

(30) Priority: **07.11.2006 US 857615 P**

(43) Date of publication of application:
05.08.2009 Bulletin 2009/32

(73) Proprietor: **Boston Scientific Limited**
Christ Church (BB)

(72) Inventors:
• **CHU, Michael S. H.**
Brookline, Massachusetts 02446 (US)

• **BIALOBRZESKI, Robert W.**
Hampton, New Hampshire 03842 (US)

(74) Representative: **Golkowsky, Stefan et al**
Pfenning, Meinig & Partner GbR
Patent- und Rechtsanwälte
Joachimstaler Strasse 10-12
10719 Berlin (DE)

(56) References cited:
WO-A-98/48713 WO-A-03/105701
US-A- 5 386 818 US-A1- 2003 045 900
US-A1- 2005 251 167 US-A1- 2006 041 263

EP 2 083 706 B1

Note: Within nine months of the publication of the mention of the grant of the European patent in the European Patent Bulletin, any person may give notice to the European Patent Office of opposition to that patent, in accordance with the Implementing Regulations. Notice of opposition shall not be deemed to have been filed until the opposition fee has been paid. (Art. 99(1) European Patent Convention).

Description**Technical Field**

[0001] The invention generally relates to placing sutures. Embodiments according to the invention can be used to navigate tortuous pathways for the purpose of accessing difficult-to-reach treatment areas within the body of a patient.

Background Information

[0002] Suturing body tissue is a time consuming aspect of many surgical procedures. For many surgical procedures, it is necessary to make a large opening in the human body to expose the area that requires surgical repair. There are instruments available, such as endoscopes, that allow viewing of certain areas of the human body through a small puncture wound without exposing the entire body cavity. Endoscopes can be used in conjunction with specialized surgical instruments to detect, diagnose, and repair areas of the body that previously required open surgery to access.

[0003] Some surgical instruments used in endoscopic procedures are limited by the manner in which they access the areas of the human body in need of repair. In particular, the instruments may not be able to access tissue or organs located deep within the body or that are in some way obstructed. Also, many of the instruments are limited by the way they grasp tissue, apply a suture, or recapture a needle and suture. Furthermore, many of the instruments are complicated and expensive to produce due to the numerous parts and/or subassemblies required to make them function properly.

[0004] Suturing instruments, and more specifically suturing instruments used in endoscopic procedures, are generally rigid and do not provide the operator a range of motion to access difficult-to-reach parts of the anatomical region requiring sutures. Accordingly, multiple instruments of various configurations and sizes typically are used to access all of the necessary tissue areas. These limitations of known suturing instruments complicate the endoscopic procedure for the surgeon by requiring the insertion and removal of multiple instruments from a surgical site as the target suturing area changes during the course of the surgical procedure.

[0005] WO 03/105701 A, which discloses the device according to the preamble of claim 1, describes a suturing instrument for placing one or more sutures through tissue of a patient's body. The suturing instrument includes a distal end that is deflectable and/or pivotably coupled to the remainder of the instrument. The distal end deflects or pivots in response to a user manipulating internal mechanisms of the instrument, such as control levers

[0006] US 2006/041263 A1 describes an instrument for performing a surgical procedure, such as passing a suture. The instrument includes a distal portion that is pivotally coupled to an elongate member of the instru-

ment. The distal portion pivots in response to a user manually depressing a button disposed on a handle of the instrument, which causes a push rod to slide distally within the elongate member and manipulate the position of the distal portion.

Summary of the Invention

[0007] The invention generally relates to suturing instruments with improved maneuverability, efficiency, and functionality for use during a surgical procedure such as an endoscopic or laparoscopic procedure, and particularly a suturing instrument capable of delivering a suture to a treatment area wherein the treatment area is located in a difficult-to-reach area within the body of a patient.

[0008] This object according to the invention is achieved by a suturing instrument which comprises the features of claim 1. Preferred embodiments of this instrument are defined in the subclaims.

[0009] Various medical procedures require a substantially linear instrument in order to reach the treatment area and a non-linear instrument once the instrument reaches the treatment area. For example, the body of the instrument must be fairly linear in order to fit through the cannula of a trocar assembly. The transformation from a substantially linear instrument to a non-linear instrument can be achieved with, for example, an instrument including a head that can be positioned straight or at an angle relative to the shaft of the instrument.

[0010] A suturing instrument includes a suturing head that is coupled to the shaft of an elongate body member by a connector member which may be biased in either a linear orientation along the longitudinal axis of the shaft or any one of a variety of non-linear orientations with respect to the shaft's longitudinal axis. The elongate body member includes a handle at a proximal portion that is engaged to a suturing head at a distal portion by a connector member, the suturing head including a needle carrier and a needle catch. The connector member can comprise a resilient material such that an external force may be applied to the suturing head and move the suturing head from a biased orientation (e.g., linear) to an unbiased orientation (e.g., non-linear). Once the external force is removed, the resiliency of the connector member allows the suturing head to return from the unbiased orientation to the biased orientation. Therefore, a user may adjust the shape of the instrument by applying or removing an external force on the suturing head, such as, for example, pressing the suturing head against the pelvic floor, or placing the suturing head and connector member within the confines of a cannula. A needle is partially disposed within a needle carrier, with a suture attached on one end and a tissue-penetrating tip on the other end. An actuator is used to deliver the needle from the needle carrier to the needle catch. In another embodiment, the suturing instrument can hold and deploy a plurality of suturing needles. In a further embodiment, each suturing needle can be attached to a distinct suture, thereby al-

lowing for the placement of a plurality of sutures prior to removal of the suturing device. The suturing head can define a recess of its surface adjacent to the concave side of the needle carrier. Alternatively, the suturing head does not define such a recess, remaining relatively flat on the surface adjacent to the concave side of the needle carrier to improve its suturing performance in certain circumstances. One such circumstance can include the anastomosis of a lumen (such as a urethra) in which the suturing head is disposed within the lumen, and the suturing needle traverses from the inside to the outside wall of the lumen.

[0011] In one embodiment, the connector member can comprise a spring or a plurality of springs, the spring being either in linear orientation or in a pre-formed non-linear or 'bent' orientation. In another embodiment, the connector member can be constructed of a polymer or a flexible plastic.

[0012] The elongate body, connector member and suturing head of the suturing instrument can fit and move rotationally and slidably within a cannula. The cannula can comprise, for example, a laparoscopic trocar assembly.

[0013] The suturing head is movable independently of the elongate body member in response to an external force. The elongate body, connector member and suturing head can be slidably disposed within a cannula.

[0014] The flexible connector member can be biased such that the elongate body member is in a non-linear orientation with respect to the suturing head. The suturing head can be aligned with the elongate body member by an externally applied force, such as when it is placed within a cannula.

Brief Description of the Drawings

[0015] The disclosed embodiments will be further explained with reference to the attached drawings, wherein like structures are referred to by like numerals throughout the several views. The drawings are not necessarily to scale, the emphasis having instead been generally placed upon illustrating the principles of the invention and the disclosed embodiments.

[0016] FIG. 1A is a schematic plan view of one embodiment of a suturing instrument in accordance with the invention;

[0017] FIGS. 1B and 1C are schematic cross-sectional views of a proximal portion and a distal portion of the suturing instrument of FIG. 1A;

[0018] FIG. 2 is an embodiment of the presently disclosed suturing instrument;

[0019] FIG. 3A. shows the suturing instrument of FIG. 2 traveling to a treatment area. FIG. 3B shows the suturing instrument of FIG. 2 engaging the treatment area. FIG. 3C shows the suturing instrument of FIG. 2 being removed from the treatment area;

[0020] FIG. 4 shows an embodiment wherein the suturing instrument is rotated about an axis of an elongate

body member;

[0021] FIG. 5A shows an embodiment of the presently disclosed suturing instrument wherein the suturing head is biased in a non-linear orientation with respect to the elongate body member. FIG. 5B shows the suturing instrument of FIG. 5A being delivered to a treatment area wherein the instrument has been surrounded by a cannula from, for example, a trocar assembly. FIG. 5C shows the suturing instrument of FIG. 5A wherein the suturing head exits the cannula at the treatment area and thereby regains the initial non-linear orientation with respect to the elongate body member;

[0022] FIG. 6A is an enlarged cross-sectional view of the distal portion of the suturing instrument of FIG. 1A;

[0023] FIG. 6B is a schematic top view of the suturing instrument of FIG. 6A taken at line B-B;

[0024] FIG. 7A is a schematic plan view of a needle coupled to a suture for use in a suturing instrument in accordance with the invention;

[0025] FIG. 7B is a schematic perspective view of a needle catch for use with the suturing instrument of FIG. 1A;

[0026] FIGS. 8A-8E are partial schematic cross-sectional views of the distal portion of the Suturing instrument of FIG. 1A during various operational phases;

[0027] FIG. 9 is a 3-dimensional view of a suturing head of an instrument in which the suturing head does not define a recess adjacent to the inside arc of the needle carrier. This embodiment is useful, for example, in the anastomosis procedure depicted in FIGS. 10-19.

[0028] FIG. 10 is a 3-dimensional perspective view of a suturing instrument (such as the instrument of FIG. 9) with the suturing head angled with respect to the long axis of the instrument and inserted into the lumen of a body structure (such as a urethra).

[0029] FIG. 11 is a side-view schematic illustration of the suturing instrument of FIG. 10 inserted into the abdominal cavity, with the suturing head inserted into the proximal end of a transected urethra. In this illustration, the upper portion of the body is located on the right.

[0030] FIG. 12 is a side-view schematic illustration of the suturing instrument of FIG. 10 in the abdominal cavity oriented away from the transected urethra, with the suturing head inserted into the urethral orifice of the neck of the bladder.

[0031] FIG. 13 is a schematic illustration of the suturing material having been threaded through the urethra and the neck of the bladder, with the suture ends brought out through the laparoscopic trocar cannula for subsequent tying and approximation of the urethra with the bladder. In this illustration, the upper portion of the body is located on the left.

Description

[0032] Illustrative embodiments according to the invention are directed towards a suturing instrument including a suturing head that is coupled to the shaft of an

elongate body member of the instrument by a connector member which may be biased in either a linear orientation along the longitudinal axis of the shaft or any one of a variety of non-linear orientations with respect to the shaft's longitudinal axis. The connector member can comprise a resilient material such that an external force may be applied to the suturing head and move the suturing head from a biased orientation (e.g., linear) to an unbiased orientation (e.g., non-linear). Once the external force is removed, the resiliency of the connector member allows the suturing head to return from the unbiased orientation to the biased orientation. Therefore, a user may adjust the shape of the instrument by applying or removing an external force on the suturing head.

[0033] As will be discussed below, the external force may be supplied by an operator (such as a surgeon or other medical professional) manipulating the shaft of the instrument, or more typically a handle connected to the shaft, to cause the suturing head to contact a treatment area within the body of a patient. The operator then applies a force that causes the connector member to give and the head to deflect. Alternatively, the external force may be applied to the suturing head by surrounding the instrument with the cannula of a trocar assembly. Any one of a wide range of external forces may be used to adjust the position and orientation of the suturing head.

[0034] By relying on an external force to adjust the suturing head as opposed to mechanically adjusting the suturing head directly (see, for example, co-owned U.S. Patent No. 6,955,643 issued October 18, 2005, and U.S. Patent No. 6,936,054 issued August 30, 2005), the suturing head may more easily travel a tortuous pathway to a treatment area because the head will deflect when coming into contact with tissue on the way to the treatment area. As such, the presently disclosed embodiments may lead to reduced tissue damage. In addition, the presently disclosed embodiments are easier and less expensive to construct as compared to a suturing instrument wherein movement of the suturing head is controlled by mechanically coupling the suturing head to a handle of the instrument.

[0035] FIG. 1A depicts a presently disclosed embodiment of a suturing instrument 100 including a handle 102, an elongate body member 104, and a needle deployment mechanism 110. The suturing instrument 100 also includes a distal portion 106 and a proximal portion 108. A suturing head 107 is located at the distal portion 106. The various components of the suturing head 107 will be discussed in detail below. The elongate body member 104 is mechanically coupled to the handle 102 at the proximal portion 108 and the suturing components are at least partially disposed within the suturing head 107 of the suturing instrument 100. The suturing instrument 100 comprises a connector member 114 which allows the suturing head 107 to move independently of the elongate body member 104.

[0036] The handle 102 could take a variety of forms, for example, the handle 102 could be one of the types

used with Boston Scientific Corporation suturing systems, in particular the Capiro® Push & Catch suturing system. Generally, the needle deployment mechanism 110 extends longitudinally through the elongate body member 104 to the distal portion 106 of the suturing instrument 100, where the needle deployment mechanism 110 is coupled to a needle 128 (FIG. 6A). The needle deployment mechanism 110 moves the needle 128 between a retracted position and a deployed position. The needle deployment mechanism 110 is shown in greater detail in FIGS. 1B and 1C.

[0037] Referring to FIG. 1B, the proximal portion 108 of the suturing instrument 100 includes the handle 102, the elongate body member 104, a suture clip 144, and the needle deployment mechanism 110. The suture clip 144 may be coupled to the handle 102 or the elongate body member 104 and is used to hold an end of one or more sutures prior to placement in a patient. The needle deployment mechanism 110 includes an actuator 112 (button 117, shaft 116), a bearing 118, a button end 119, and a hole 121. The bearing 118 rides along a cylindrical surface 105 that is formed by the inside diameter of the elongate body member 104. A wireform 103 is inserted into the hole 121, coupling it to the actuator button 117. A spring 115 encircles the wireform 103, abuts the button end 119, and is compressed between the button end 119 and a spring washer 113. The spring washer 113 is seated upon a center tube 107. The center tube 107 is housed by the cylindrical surface 105 and is constrained in the distal portion 106. A pusher wire 111 is attached to the wireform 103 by means of a weld, a coupling, adhesive or other means, and is slidably disposed within a guidance sleeve 109, the sleeve 109 being disposed within a cylindrical surface 123 formed by the inside diameter of the center tube 107. In one embodiment, the pusher wire 111 is constructed of nitinol, so chosen for its combination of properties that allow for bendability and high column strength when constrained. Nitinol is a nickel-titanium alloy. Those skilled in the art will recognize that the wire may comprise various materials; these materials are all within the spirit and scope of the present invention.

[0038] Referring to FIG. 1C, the suturing head 107 of the suturing instrument 100 of FIG. 1A includes the elongate body member 104, the needle deployment mechanism 110, a connector member 114, a curved portion 126, and a needle catch 122. Referring again to the needle deployment mechanism 110, the pusher wire 111 is attached by welding or other means to a coupling 150, which is slidably disposed within a track 152. The coupling 150 is attached to a carrier wire 154, which by virtue of its attachment to the coupling 150 is also slidably disposed within the track 152. The carrier wire 154 is mechanically coupled to an extendable needle carrier 124 by means of a weld, a coupling, adhesives, or other means. The coupling 150 abuts a backstop washer 156 that is slidably disposed about the pusher wire 111 and is contained within a pocket 160 that includes a back wall 162, against which the backstop washer 156 rests. The

track 152 terminates distally in a pocket 164 that includes a wall 166. A downstop washer 158 is slidably disposed about the carrier wire 154 and constrained within the pocket 164.

[0039] Various medical procedures require the suturing instrument 100 to enter the body in a linear or substantially linear shape, assume a non-linear shape once the instrument has reached the treatment area, and subsequently revert to a linear or substantially linear shape prior to being removed from the body. In addition, several medical procedures require an instrument capable of traveling a tortuous pathway with minimal damage to healthy tissue. The presently disclosed suturing instrument 100 comprises a connector member 114 which allows for the suturing instrument 100 to transform from a linear shape to a non-linear shape in response to an external force applied to the suturing head 107 of the suturing device 100. In addition, the presence of the connector member 114 allows for the suturing head 107 to easily deflect when engaging a healthy tissue while traveling to the treatment area.

[0040] FIG. 2 shows various aspects of an embodiment of the presently disclosed suturing instrument 100. The suturing instrument 100 comprises an elongate body member 104 wherein the elongate body member 104 comprises a handle 102 at a proximal portion 108. At a distal portion 106, the elongate body member 104 comprises a suturing head 107 engaged to the elongate body member 104 by a connector member 114.

[0041] The suturing instrument 100 allows for the suturing head 107 to move independently of the elongate body member 104 by essentially decoupling the suturing head 107 from the elongate body member 104 at the connector member 114. This decoupling allows the suturing head 107 to maintain a linear orientation relative to the elongate body member 104 while the suturing instrument 100 is being delivered to the treatment area and assume a non-linear orientation relative to the elongate body member 104 once the suturing instrument 100 arrives at the treatment area and is subjected to an external force.

[0042] In an embodiment, the connector member 114 comprises a flexible spring. In an embodiment, the spring is free to bend in any direction relative to the elongate body member 104. In an embodiment, the spring is covered with a shrink wrap material (or any other suitable material) to prevent matter from entering the suturing instrument 100 through the coils of the spring.

[0043] In an embodiment, the connector member 114 comprises a plurality of springs. In an embodiment, each of the plurality of springs comprises a distinct strength and/or stiffness.

[0044] In an embodiment, the connector member 114 comprises a flexible inner-tube and a straight outer spring. The inner-tube prevents the nitinol wire from buckling when in compression. The suturing head 107 assumes an angle with respect to the elongate body member 104 when the suturing head 107 is pressed

against a treatment area, such as the pelvic floor or inside the urethra.

[0045] In an embodiment, the connector member 114 comprises a flexible inner tube and a curved outer spring. The curved outer spring maintains an angled orientation with respect to the elongate body member 104, unless an external force is applied to place the suturing head 107 in a linear orientation with the elongate body member 104. Such an external force can occur, for example, when the suturing head 107, the connector 114 and the elongate body member 104 are confined within a cannula as the suturing instrument 100 is inserted into or withdrawn from a body cavity. When the suturing head 107 is in a linear orientation with the elongate body member 104, rotating the needle deployment mechanism 110 about the axis of the elongate body member 104 of the suturing instrument 100 will cause the suturing head 107 to also rotate about the axis of the elongate body member 104. On the other hand FIG. 10 shows that when the suturing head 107 is in an angled position relative to the elongate body member 104, rotating the needle deployment mechanism 110 in a direction of rotation "A" about the axis "X" of the suturing instrument 100 will cause the suturing head 107 to rotate in a direction of rotation "B" about its own axis "Y". As a result, the suturing head 107 can be made to rotate to a different suturing position while remaining within the lumen of the structure being sutured (such as the urethra), as depicted in FIG. 10.

[0046] In an embodiment, the connector member 114 comprises a flexible polymer. In an embodiment, the connector member 114 comprises a flexible plastic. Those skilled in the art will recognize that any resilient material capable of allowing the suturing head 107 to move relative to the elongate body member 104 is within the scope of the present invention.

[0047] FIG. 3A shows an embodiment wherein the suturing instrument 100 is being delivered to a treatment area. In an embodiment, the treatment area is the pelvic floor. As shown in FIG. 3A, the suturing head 107 is substantially linear with respect to the elongate member 104 of the suturing instrument 100 as the suturing instrument 100 navigates a tortuous path to the treatment area. In various medical procedures, a linear device is necessary to reach the treatment area; more specifically, a non-linear device could not navigate the small diameter openings (for example, the cannula of a laparoscopic trocar assembly) through which the suturing instrument 100 needs to travel to reach a desired area. However, once the suturing instrument 100 reaches the treatment area, a non-linear device is required to perform the necessary procedure; i.e., the placement of sutures 136.

[0048] FIG. 3B shows the suturing instrument 100 reaching the treatment area (i.e., the pelvic floor). As shown, the suturing head 107 engages the pelvic floor and is pushed against the pelvic floor. As the pelvic floor supplies an external force to the suturing head 107, the suturing head 107 assumes a non-linear orientation with respect to the elongate body member 104. The non-linear

orientation is possible because the suturing head 107 is decoupled from the elongate body member 104 at the connector member 114. As discussed above, the connector member 114 comprises a flexible material allowing the suturing head 107 to bend relative to the elongate body member 104 in response to an external force. Once the non-linear orientation is assumed, the suturing instrument 100 is ready to supply sutures 136 to the treatment area (as discussed in detail below).

[0049] FIG. 3C shows the removal of the suturing instrument 100 from the treatment area. As the suturing instrument 100 is withdrawn, the external force acting on the suturing head 107 is removed (i.e., the pelvic floor is no longer exerting a force on the suturing head 107). With the removal of this external force, the suturing head 107 resumes the initial linear orientation with respect to the elongate body member 104. The connector member 114 comprises a resilient, flexible material which allows the suturing head 107 to move in all directions relative to the elongate body member 104 in response to an external force; however, the resiliency of the connector member 114 allows the suturing head 107 to resume the initial linear orientation to the elongate body member 104 once the external force is removed. Once the suturing head 107 has resumed a substantially linear orientation with respect to the elongate body member 104, the suturing instrument 100 may be retracted from the treatment area and out of the body.

[0050] FIG. 10 shows an embodiment wherein the needle deployment mechanism 110 is rotated in the "A"-direction (as shown by an arrow) about an "X" axis of the elongate body member 104. By rotating inner tube within the elongate body member 104 about the "X"-axis in the direction of arrow "A", the suturing head 107 rotates about an axis "Y" in the direction of arrow "B". The flexible inner tube can be a flexible spring 115 situated within a larger flexible polymer connector member 114. Rotation of the needle deployment mechanism 110 causes rotation of the suturing head 107 about its axis "Y" through the rotation of the flexible inner tube within the connector member 114. A further embodiment shown in FIG. 10 includes a ratchet assembly 210 to maintain the axial orientation suturing head 107 during insertion of the suturing instrument 100 through a cannula. In an embodiment, the suturing head 107 is rotated prior to inserting the instrument 100 into a body.

[0051] FIG. 5A shows an embodiment wherein the suturing head 107 is biased towards a substantially non-linear orientation with respect to the elongate body member 104 of the suturing instrument 100. The initial non-linear orientation is possible because the connector member 114 is pre-formed at an angle such that in the absence of an exterior force, the suturing head 107 remains in a substantially non-linear orientation with respect to the elongate body member 104.

[0052] In an embodiment, the connector member 114 is a pre-formed bent spring. In an embodiment, the connector member 114 comprises a pre-formed polymer. In

an embodiment, the connector member 114 comprises a pre-formed plastic. Those of skill in the art will recognize that the connector member 114 may comprise various materials and remain within the scope of the present invention.

[0053] FIG. 5B shows the suturing instrument 100 of FIG. 5A wherein the suturing instrument 100 has been partially surrounded by the cannula 29 of a trocar assembly. (As used herein, a trocar assembly consists of an obturator and a cannula, in which the obturator has a pointed end and can slide within the lumen of the cannula, and can penetrate the skin or wall of an organ, allowing the cannula to be subsequently left in place). The cannula 29 produces an external force on the connector member 114 which substantially straightens the connector member 114 thereby resulting in a substantially linear relationship between the suturing head 107 and the elongate body member 104.

[0054] In an embodiment, the cannula 29 comprises a bio-compatible plastic. In an embodiment, the cannula 29 comprises a bio-compatible polymer. In an embodiment, the cannula 29 is a laparoscopic cannula 29. The cannula 29 comprises a material capable of supplying an external force on the suturing instrument 100 which results in a substantially linear relationship between the suturing head 107 and the elongate body member 104 of the suturing instrument 100. Therefore, the suturing instrument 100 surrounded by the cannula 29 may be delivered to the treatment area while maintaining a substantially linear relationship between the suturing head 107 and the elongate body member 104.

[0055] Once the cannula 29 reaches the treatment area, the suturing instrument 100 resumes a non-linear orientation by exiting the cannula 29. FIG. 5C shows the suturing instrument 100 exiting the cannula 29 at the distal cannula opening 31. Once the connector member 114 substantially exits the cannula 29, the cannula 29 is no longer supplying an external force on the connector member 114; therefore, the connector member 114 is free to reassume a pre-formed bent configuration wherein the suturing head 107 assumes a non-linear orientation as compared to the elongate body member 104. Once the suturing procedure is complete, the suturing head 107 is withdrawn into the cannula 29 and regains the substantially linear orientation. Once inside the cannula 29, the suturing instrument 100 may be withdrawn from the body.

[0056] Referring to FIGS. 6A and 6B, the curved portion 126 defines a channel 178, an opening (or needle exit port 120) including a tunnel or (needle compartment 140), a needle input/output slot 142, and a suture slot 146. The curved portion 126 also defines a recess 176 for receiving tissue (FIG. 1C). The curved portion 126 also includes a knot pusher 184. The needle carrier 124 is disposed within the channel 178 in the curved portion 126. A distal portion 180 of the needle carrier 124 defines a lumen 138 for holding a needle 128a, 128b, or 128c (generally needle 128). An alternative embodiment is

shown in FIG. 9, in which the suturing head 107 does not define a recess 176 as shown in FIG. 1C and FIG. 8A. Instead, the contour of the suturing head at 176A of FIG. 9 is relatively flat. Absence of the recess 176 helps to prevent the prolapse of tissue inward within the inside arc of the needle carrier 124 when the suturing head 107 is placed within a lumen to suture through the wall of the lumen. The distortion created by the prolapse of tissue could otherwise disturb the proper placement of the needle 128. This design is useful, for example, in the anastomosis of the transected urethra to the urethral orifice of the neck of the bladder during radical prostatectomy surgery, as described later and schematically illustrated in FIGS. 10 to 13.

[0057] Referring to FIG. 7A, in one embodiment, the needle 128 includes a tip 130 and a shaft 134 coupled to the tip 130, thereby forming a shoulder 132. The shaft 134 is coupled to a suture 136a, 136b, 136c (generally suture 136). The needle 128 is inserted into the lumen 138 and held by a slight friction fit. The suture 136 extends out of a needle carrier suture slot 148 and the suture slot 146. Needles 128b and 128c are stored in the needle compartment 140 prior to being deployed.

[0058] Referring again to FIGS. 1B, 1C, 6A, and 6B, in operation, a user (such as a physician or other medical personnel) actuates the needle deployment mechanism 110 by pushing on the button 117, which via the attachment to the wireform 103 which is attached to the pusher wire 111, moves the coupling 150 along the track 152 concomitantly moving the carrier wire 154, which slidably moves the needle carrier 124 through the needle exit port 120. The user continues to push the button 117 until the needle 128 enters the needle catch 122. The needle catch 122, as shown in FIG. 7B, includes openings 170 defined by successive ribs 172. The needle catch 122 receives the needle 128 (coupled to the suture 136) through opening 170, the ribs 172 deflect slightly to allow the needle 128 to pass through. After the formed shoulder 132 has passed the ribs 172, the ribs 172 spring back to their original position defining the openings 170, and the needle 128 remains captured in the needle catch 122. The user releases the button 117 and the spring 115 urges the button 117 proximally, moving the pusher wire 111, the coupling 150, the carrier wire 154, and the needle carrier 124 proximally along with the button 117 to the retracted position. As the needle carrier 124 moves back to the retracted position, the needle 128 slides out of the lumen 138. The openings 170 are chosen to be smaller in dimension than the formed shoulder 132. This causes the needle catch 122 to retain the needle 128 because the flat rear surface of the shoulder 132 prevents the needle 128 from passing back through the opening 170. When it is necessary to remove the needle 128 from the needle catch 122, the needle 128 may be moved toward an enlarged portion 174 of opening 172. The enlarged portion 174 is sized to allow the formed shoulder 132 to pass through without resistance. The needle catch 122 is preferably constructed of thin stainless steel of

high temper, such as ANSI 301 full hard. The needle catch 122 may be fabricated by means of stamping, laser machining, or chemical etching.

[0059] The suturing instrument's component materials should be biocompatible. For example, the handle 102, the elongate body member 104, and portions of the needle deployment mechanism 110 may be fabricated from extruded, molded, or machined plastic material(s), such as polypropylene, polycarbonate, or glass-filled polycarbonate. Other components, for example the needle 128, may be made of stainless steel. Other suitable materials will be apparent to those skilled in the art. The material (s) used to form the suture should be biocompatible. The surgeon will select the length, diameter, and characteristics of the suture to suit a particular application. Additionally, the mechanical components and operation are similar in nature to those disclosed in U.S. Pat. Nos. 5,364,408 and 6,048,351 .

[0060] Referring to FIGS. 6A-6B and 8A-8E, the present invention enables a user to place multiple sutures 136 in a patient without removing the suturing instrument 100 from the patient. The user loads the suture 136c through the first suture slot 146a until the suture 136c emerges from the second suture slot 146b. The user then inserts the needle 128c through the needle input/output slot 142 into the needle compartment 140. The user repeats this process for additional sutures 136 and needles 128. The user can repeat this process for loading the first suture 136a and the first needle 128a, or the user can insert the first needle 128a directly into the needle carrier 124. In either case, the sutures 136a, 136b, 136c extend out of the second suture slot 146b. If the needle 128a is loaded into the needle compartment 140, the user pulls on the first suture 136a (held by the suture clip 144) to cause the first needle 128a to slide down an inclined needle shelf 204 and out of the needle compartment 140 through the needle output slot 142 into the lumen 138 of the needle carrier 124. The suture 136a extends out of the needle suture slot 148 and the second suture slot 146b.

[0061] In another embodiment, the suture 136a could be pulled by attaching the suture 136a to a spool mounted on the elongate body member 104 and winding the spool. In still other embodiments, the suture 136a could be pulled by other mechanical means known in the art, such as by a lever, for example. After the needles 128a, 128b, 128c and sutures 136a, 136b, 136c are loaded into the suturing instrument 100, portions of the sutures 136a, 136b, 136c extending out the suture slot 146b are held by the suture clip 144 (FIG. 1B). The needle carrier 124, which is part of the needle deployment mechanism 110, is sequentially connectable to the needles 128 stored in the needle compartment 140. This means that each needle 128 stored in the needle compartment 140 is connected to, and then deployed by, the needle carrier 124 one at a time in the order the needles 128 are dispensed from the needle compartment 140.

[0062] The user then inserts the elongate body mem-

ber 104 into a patient and orients the elongate body member 104 so that the needle exit port 120 is proximate to or in contact with the tissue 206 to be sutured. The user then pushes the button 117 (FIG. 1B), as described above. Pushing the button 117 causes the needle carrier 124 (holding the first needle 128a) to extend out of the needle exit port 120 and push the needle 128a through the tissue 206. As the first needle 128a is pushed through the tissue 206, the first needle 128a pulls the first suture 136a through the tissue 206. As the user continues to push the button 117, the needle carrier 124 continues to advance out of the needle exit port 120 and directs the first needle 128a and the first suture 136a toward the needle catch 122. The user continues to push the button 117 until the first needle 128a contacts and becomes captured by the needle catch 122 (FIG. 8B). The user then retracts the needle carrier 124 by releasing the button 117, as previously described.

[0063] After the user retracts the needle carrier 124, the first needle 128a and the first suture 136a are left captured within the needle catch 122, with the first suture 136a extending through the tissue 206 (FIG. 8C). When the needle carrier 124 returns to a fully retracted position, the user pulls on the second suture 136b to cause the second needle 128b to slide down the inclined needle shelf 204 and out of the needle compartment 140 through the needle input/output slot 142 and into the lumen 138 of the needle carrier 124. The second suture 136b extends out of the needle carrier suture slot 148 and the second suture slot 146b. The user then advances the needle carrier 124 as described above until the second needle 128b is captured by the needle catch 122 (FIG. 8D). The user then retracts the needle carrier 124 as described above leaving the second needle 128b and the second suture 136b captured by the needle catch 122 (FIG. 8E). This procedure can be repeated for the third needle 128c, or for as many needles as may be stored in the needle compartment 140.

[0064] After one or more sutures 136 have been placed, the user withdraws the suturing instrument 100 from the patient. The user detaches the suture(s) 136 from the needle(s) 128 and ties a knot or knots into the suture(s) 136. The user can then use the knot pusher 184 (shown in FIG. 1C) to push the knot(s) into the patient as the knot(s) is tightened.

[0065] FIGS. 10-13 schematically show an embodiment of the medical device 100 being used for laparoscopic radical prostatectomy, in which the transected urethra is anastomosed to the urethral orifice of the neck of the bladder. Because of the flexibility of the connector member 114, the surgeon can insert the suturing instrument 100 through the cannula of a trocar in the anterior abdominal wall. Once inside the abdominal cavity, the suturing head 107 bends at an angle relative to the elongate body member 104, either from externally applied force against the pelvic floor, or from the intrinsic properties of the connector member 114 (comprising, for example, either a pre-formed bent spring or polymeric ma-

terial). As shown in FIG. 10, the suturing head 107 can then be inserted into the lumen of the transected urethra 213. Rotating the button 117 of the needle deployment mechanism causes the inner tube within the elongated body 104 to rotate about the long axis "X" of the elongate body member 104. This rotational movement is transmitted within the connector 114 through a ratchet assembly 210 in the suturing head 107 and rotates the suturing head 107 about its own axis "Y". The surgeon then actuates the needle deployment mechanism 110 by pushing on the button 117, deploying a suture in an inside-out fashion through the wall of the urethra, as shown in FIG. 11. In an embodiment, the outside surface of the suturing head 107 can be formed with a ridge 212 on at least one side that will stop the insertion of the suturing head 107 into the urethral lumen 213 at a pre-defined depth, allowing the instrument to reliably take an optimally sized 'bite' of tissue with the suturing needle. As shown in FIG. 12, after placement of a suture through the urethra, the suturing instrument 100 is turned in a proximal direction and inserted into the urethral orifice of the neck of the bladder 214. A second suture can then be placed, again in an inside-out fashion. In an embodiment, a single line of suture material is equipped with a needle on each end (double-armed suture), so that a single suture thread can be deployed between the distal urethra and the proximal bladder neck - one end first through the urethra, and the other end next through the urethral orifice of the bladder neck. As shown in FIG. 13, once the suture is placed through the urethra 213 and the bladder neck 214, the suturing instrument can then be withdrawn through the laparoscopic cannula 29, pulling the ends of the deployed suture material out of the abdominal cavity. At that point, each needle 128 (as shown in FIG. 7A) can then be detached from the suture material 136, and a knot can be tied between the two ends of each suture 136. The surgeon can then use a knot pusher to slide the knot down into the surgical field, and approximate the urethra 213 to the bladder neck 214 by applying tension on the knotted thread.

[0066] Certain embodiments according to the invention have been disclosed. These embodiments are illustrative of, and not limiting on, the invention. Other embodiments, as well as various modifications and combinations of the disclosed embodiments, are possible and are within the scope of the claims.

Claims

1. A suturing instrument (100) comprising:

- a handle (102);
- an elongate body member (104) extending from the handle (102) and having a distal end, the elongate body member (104) extending along a longitudinal axis;
- a connector member (114);

a suturing head (107) extending from the distal end of the connector member (114), the suturing head (107) including a needle carrier (124) and a needle catch (122);

a needle (128) partially disposed within the needle carrier (124), the needle (128) engaging a suture (136) at first end and including a tissue-penetrating tip at a second end; and an actuator (112) capable of delivering the needle (128) from the needle carrier (124) to the needle catch (122),

characterized in that

the connector member (114) comprises at least one spring or a flexible polymer and extends from the distal end of the elongate body member (104), and is resiliently deflectable off of the longitudinal axis of the elongate shaft member (104) such that the suturing head (107) is manipulatable between a linear or substantially linear orientation relative to the longitudinal axis of the elongate body member (104) and a non-linear orientation relative to the longitudinal axis of the elongate body member (104) by application of a force external to the suturing instrument (100) without manipulating internal mechanisms of the suturing instrument (100).

2. The suturing instrument of claim 1, wherein the connector member (114) comprises a pre-formed non-linear spring.
3. The suturing instrument of claim 2, further comprising a trocar for surrounding a length of the suturing instrument.
4. The suturing instrument of claim 3, wherein the trocar comprises a laparoscopic trocar.
5. The suturing instrument of claim 1, further comprising a plurality of needles (128a-c).
6. The suturing instrument of claim 5, wherein each needle (128) engages a distinct suture (136) thereby allowing for the placement of a plurality of sutures prior to removal of the suturing device.

Patentansprüche

1. Nähinstrument (100), welches aufweist:

einen Handgriff (102);
ein längliches Körperteil (104), das sich von dem Handgriff (102) erstreckt und ein distales Ende hat, welches längliche Körperteil (104) sich entlang einer Längsachse erstreckt;
ein Verbinderteil (114);
einen Nähkopf (107), der sich von dem distalen

Ende des Verbinderteils (114) erstreckt, welcher Nähkopf (107) einen Nadelträger (124) und einen Nadelfang (122) enthält;

eine Nadel (128), die teilweise innerhalb des Nadelträgers (124) angeordnet ist, wobei die Nadel (128) an einem ersten Ende mit einem Faden (136) in Eingriff ist und an einem zweiten Ende eine in Gewebe eindringende Spitze enthält; und

ein Betätigungsteil (112), das in der Lage ist, die Nadel (128) von dem Nadelträger (124) zu dem Nadelfang (122) hin zu befördern,

dadurch gekennzeichnet, dass

das Verbinderteil (114) zumindest eine Feder oder ein flexibles Polymer aufweist und sich von dem distalen Ende des länglichen Körperteils (104) erstreckt, und elastisch aus der Längsachse des länglichen Körperteils (104) heraus derart auslenkbar ist, dass der Nähkopf (107) betätigbar ist zwischen einer linearen oder im Wesentlichen linearen Orientierung relativ zu der Längsachse des länglichen Körperteils (104) und einer nichtlinearen Orientierung relativ zu der Längsachse des länglichen Körperteils (104) durch Ausüben einer externen Kraft auf das Nähinstrument (100) ohne Betätigung innerer Mechanismen des Nähinstruments (100).

2. Nähinstrument nach Anspruch 1, bei dem das Verbinderteil (114) eine vorgeformte nichtlineare Feder aufweist.
3. Nähinstrument nach Anspruch 2, weiterhin aufweisend ein Trochar, um eine Länge des Nähinstruments zu umgeben.
4. Nähinstrument nach Anspruch 3, bei dem das Trochar ein laparoskopisches Trochar aufweist.
5. Nähinstrument nach Anspruch 1, weiterhin aufweisend mehrere Nadeln (128a-c).
6. Nähinstrument nach Anspruch 5, bei dem jede Nadel (128) mit einem getrennten Faden (136) in Eingriff tritt, wodurch die Anordnung mehrerer Fäden vor der Entfernung der Nähvorrichtung ermöglicht wird.

Revendications

1. Instrument de suture (100) comprenant :

une poignée (102) ;
un élément de corps allongé (104) s'étendant depuis la poignée (102) et comprenant une extrémité distale, l'élément de corps allongé (104) s'étendant le long d'un axe longitudinal ;
un élément de connecteur (114) ;

une tête de suture (107) s'étendant depuis l'extrémité distale de l'élément de connecteur (114), la tête de suture (107) incluant un support d'aiguille (124) et un cran d'aiguille (122) ;
 une aiguille (128) partiellement disposée dans le support d'aiguille (124), l'aiguille (128) engageant une suture (136) au niveau d'une première extrémité et incluant une pointe de pénétration de tissu au niveau d'une seconde extrémité ; et
 un actionneur (112) capable de délivrer l'aiguille (128) depuis le support d'aiguille (124) jusqu'au cran d'aiguille (122),

caractérisé en ce que

l'élément de connecteur (114) comprend au moins un ressort ou un polymère flexible et s'étend depuis l'extrémité distale de l'élément de corps allongé (104), et peut être fléchi de façon élastique hors de l'axe longitudinal de l'élément d'arbre allongé (104) de telle sorte que la tête de suture (107) soit manipulable entre une orientation linéaire ou sensiblement linéaire par rapport à l'axe longitudinal de l'élément de corps allongé (104) et une orientation non linéaire par rapport à l'axe longitudinal de l'élément de corps allongé (104) par application d'une force externe à l'instrument de suture (100) sans manipuler un mécanisme interne de l'instrument de suture (100).

2. Instrument de suture selon la revendication 1, dans lequel l'élément de connecteur (114) comprend un ressort non linéaire pré-formé.
3. Instrument de suture selon la revendication 2, comprenant en outre un trocart pour entourer une longueur de l'instrument de suture.
4. Instrument de suture selon la revendication 3, dans lequel le trocart comprend un trocart laparoscopique.
5. Instrument de suture selon la revendication 1, comprenant en outre une pluralité d'aiguilles (128a-c).
6. Instrument de suture selon la revendication 5, dans lequel chaque aiguille (128) engage une suture distincte (136) permettant ainsi le placement d'une pluralité de sutures avant l'enlèvement du dispositif de suture.

55

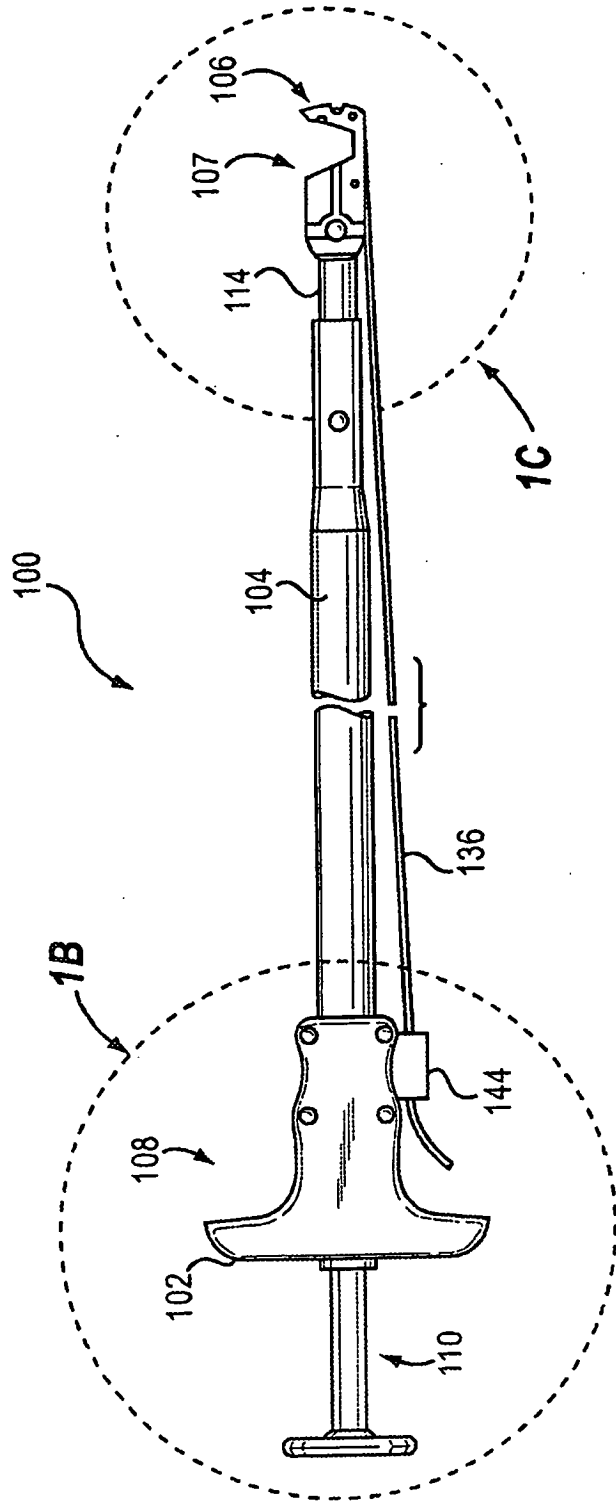

Fig.1A

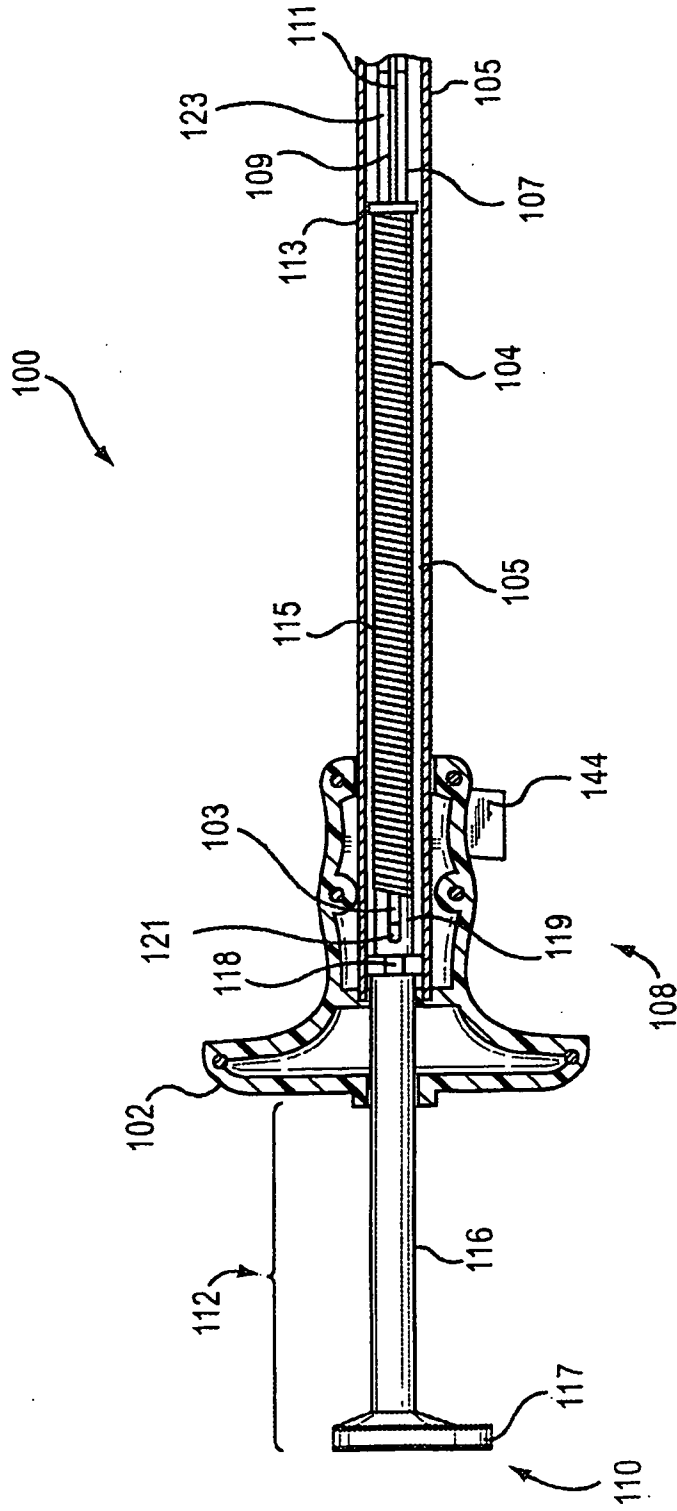

Fig.1B

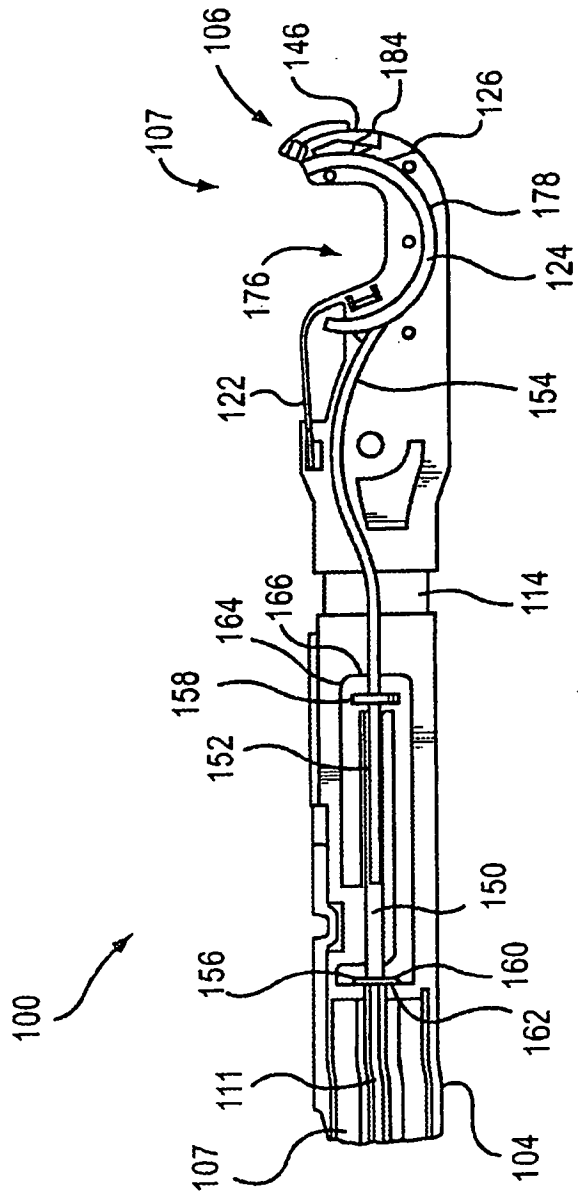

Fig. 1C

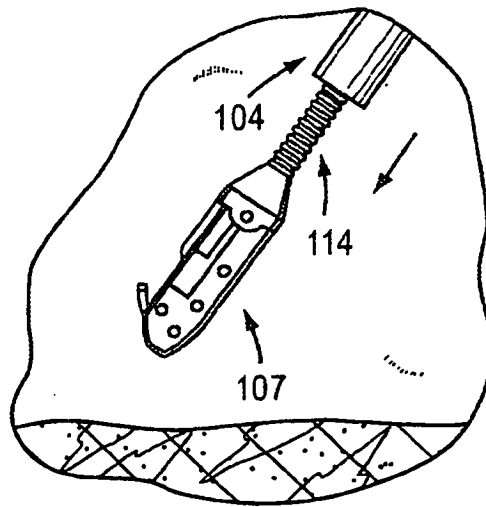
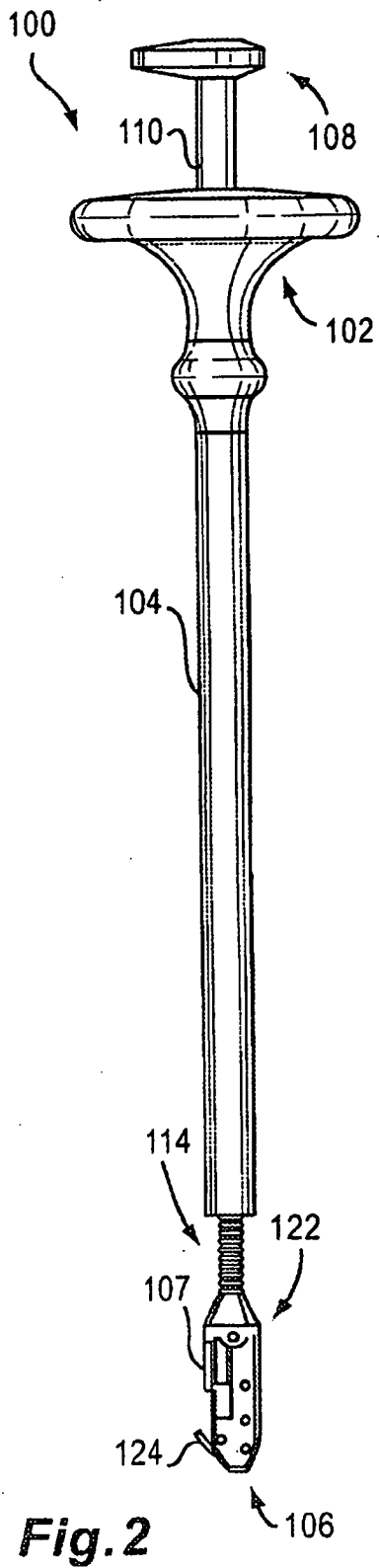

Fig. 3A

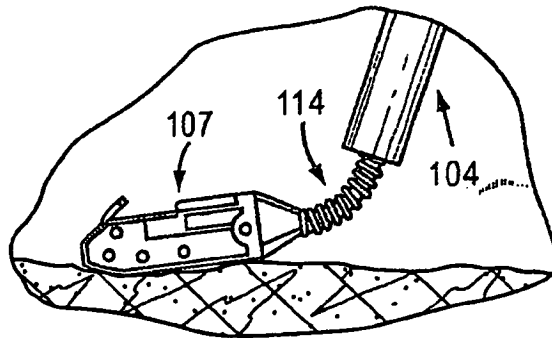

Fig. 3B

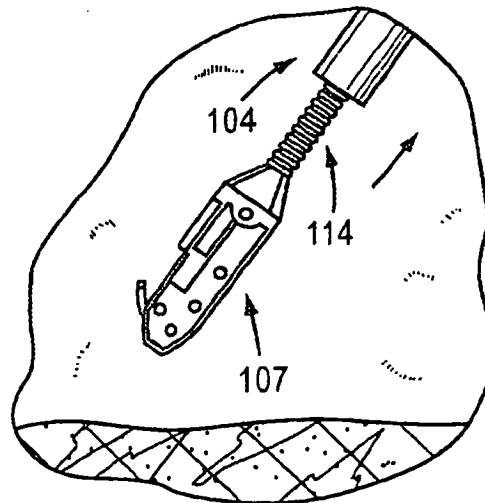

Fig. 3C

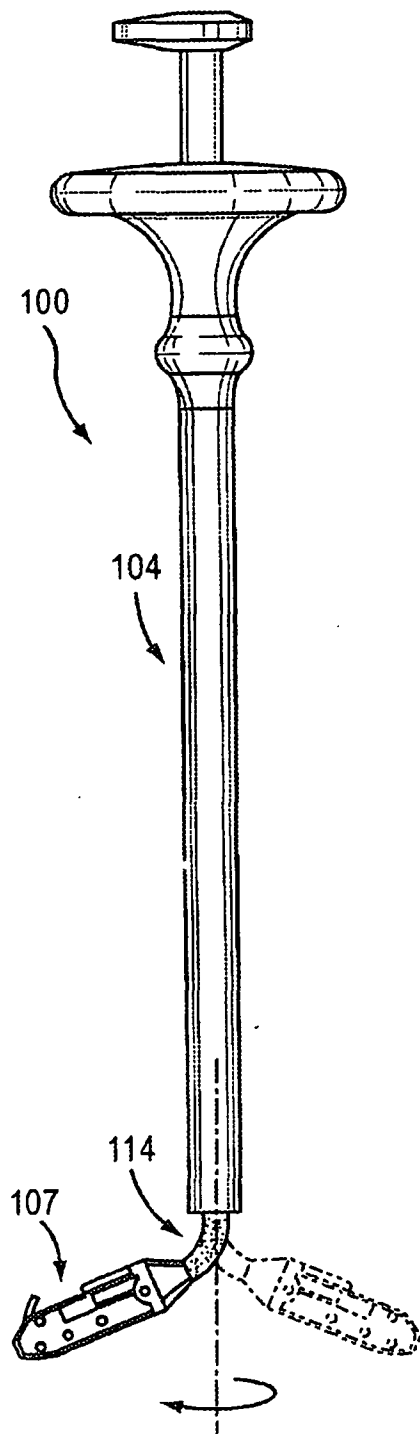

Fig. 4

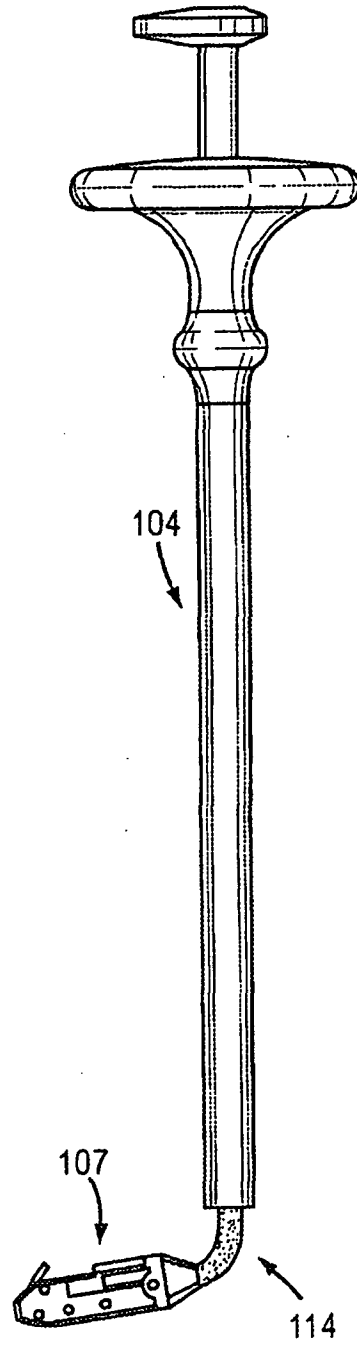

Fig. 5A

Fig.5B

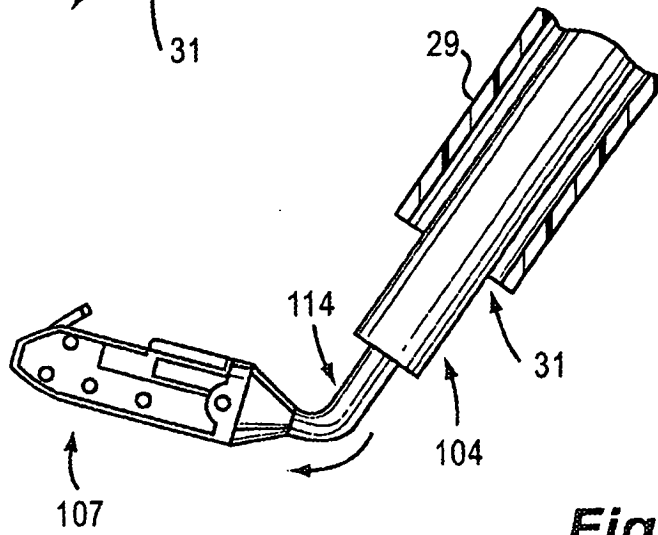
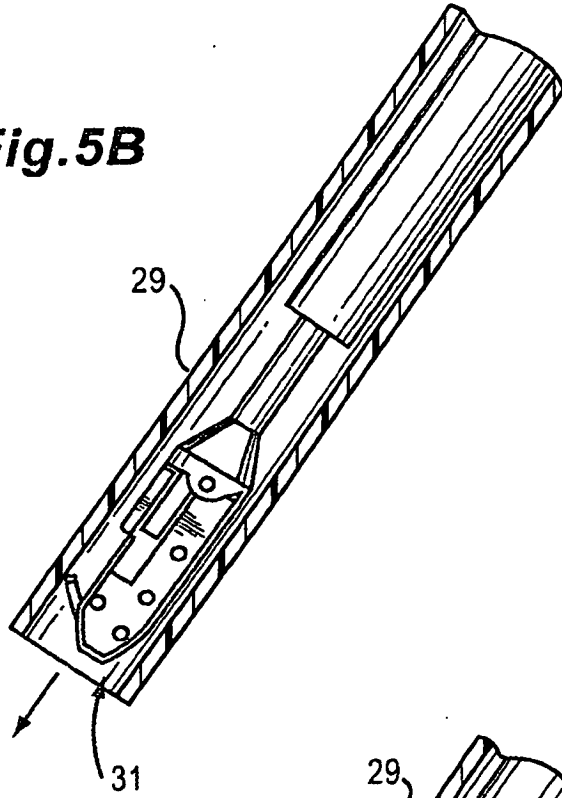

Fig.5C

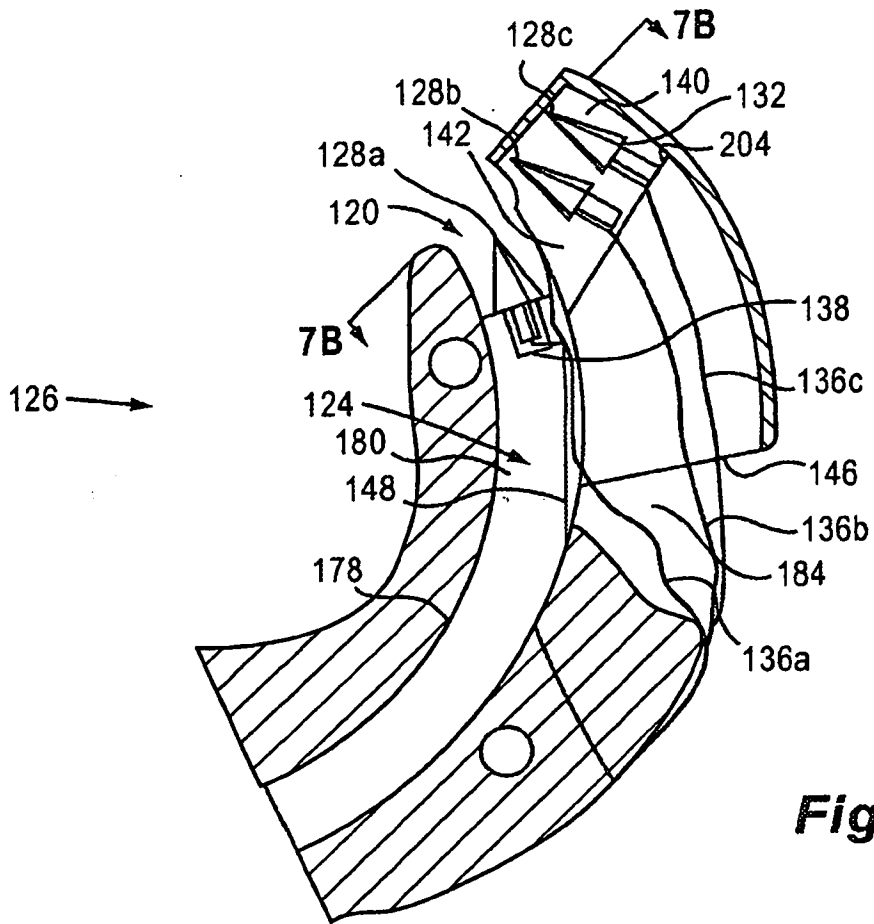

Fig. 6A

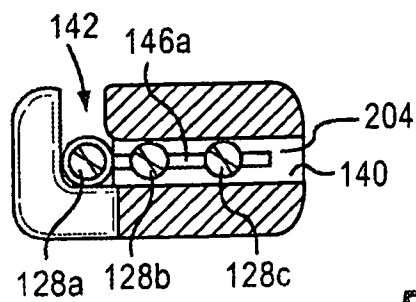

Fig. 6B

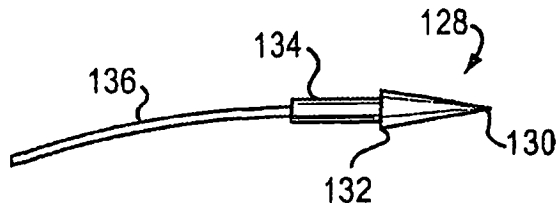

Fig. 7A

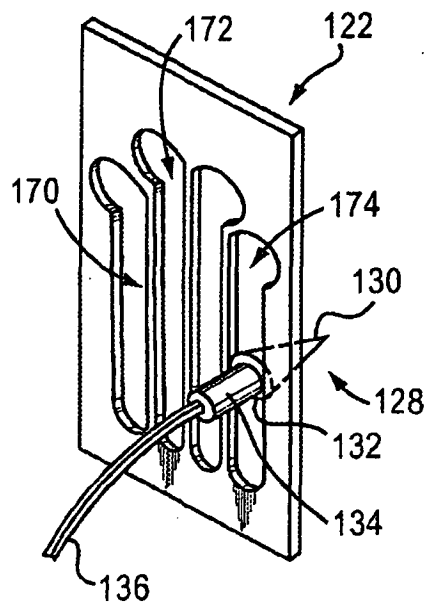

Fig. 7B

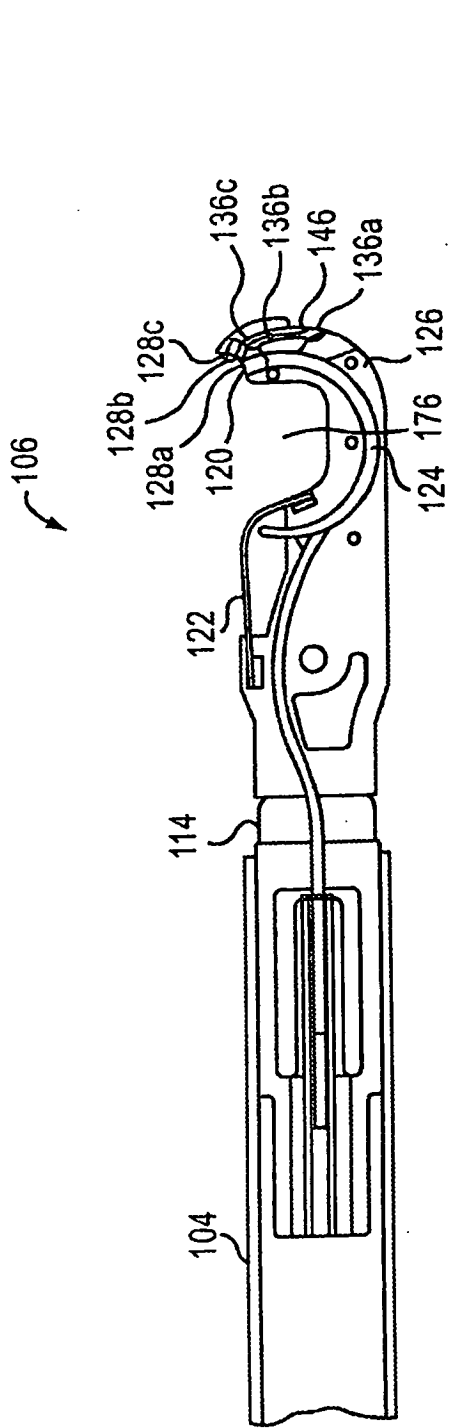

Fig. 8A

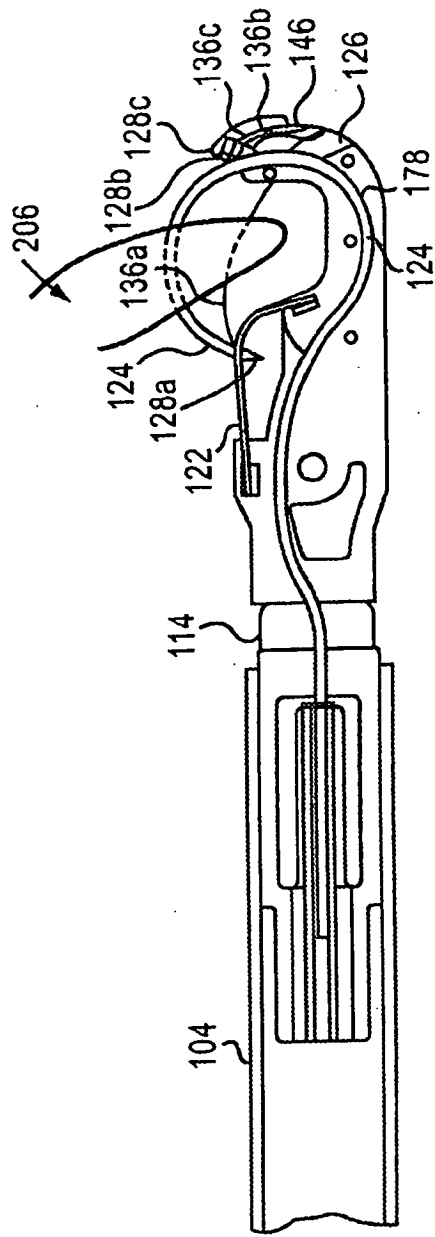

Fig. 8B

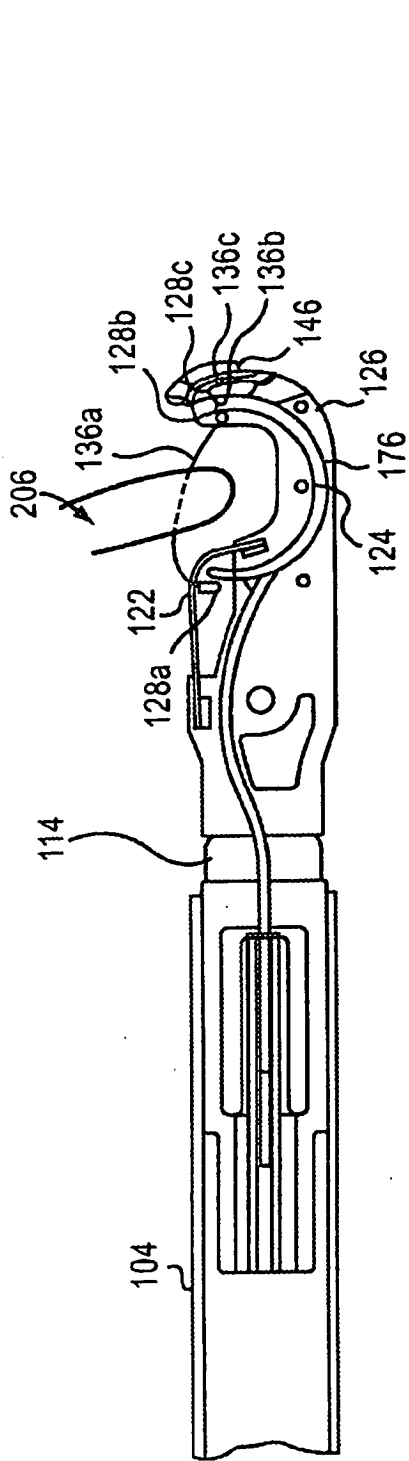

Fig. 8C

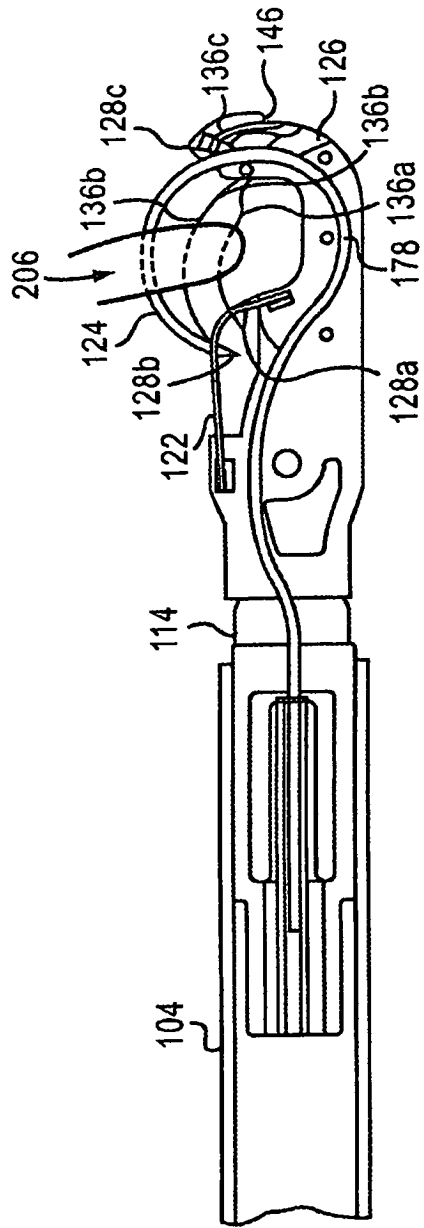

Fig. 8D

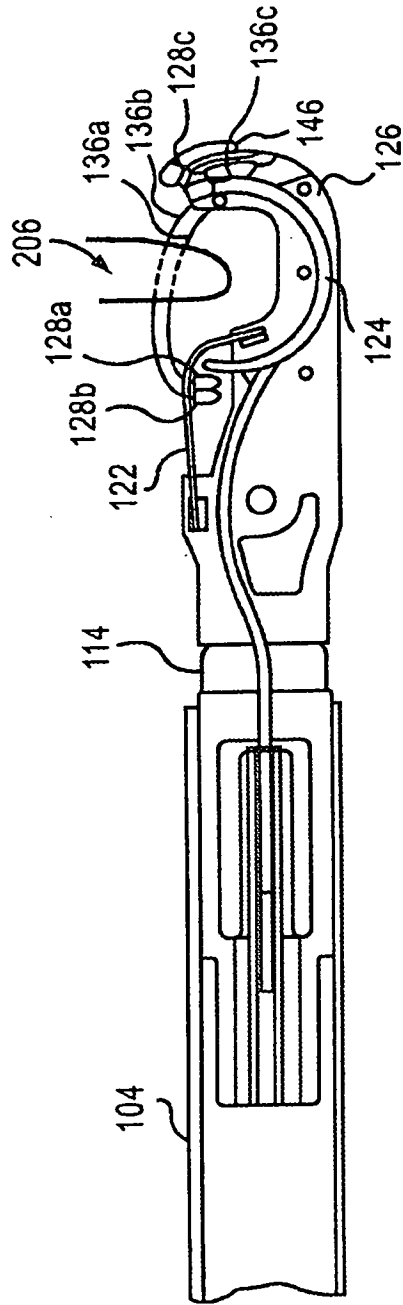

Fig. 8E

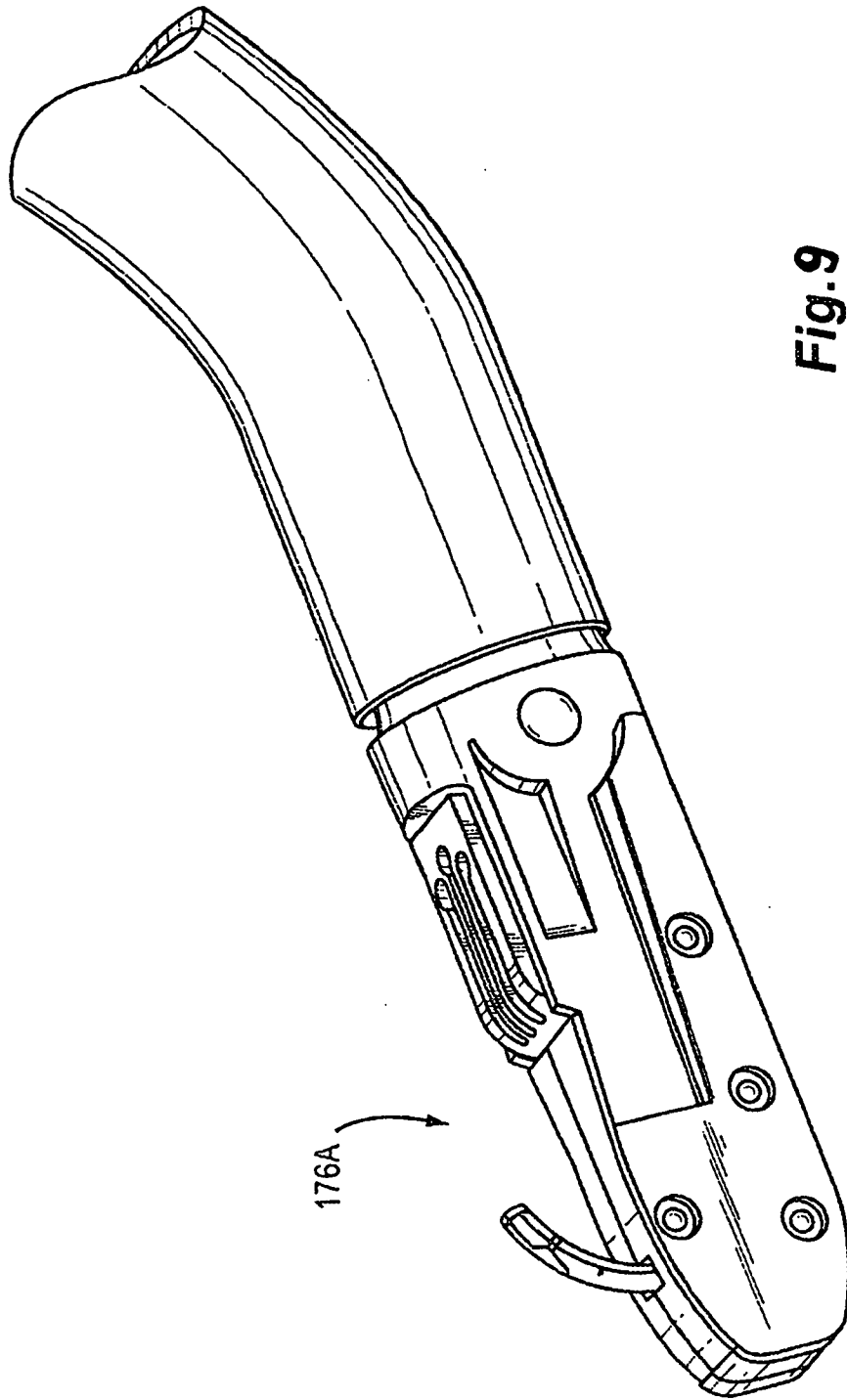

Fig. 9

Fig. 10

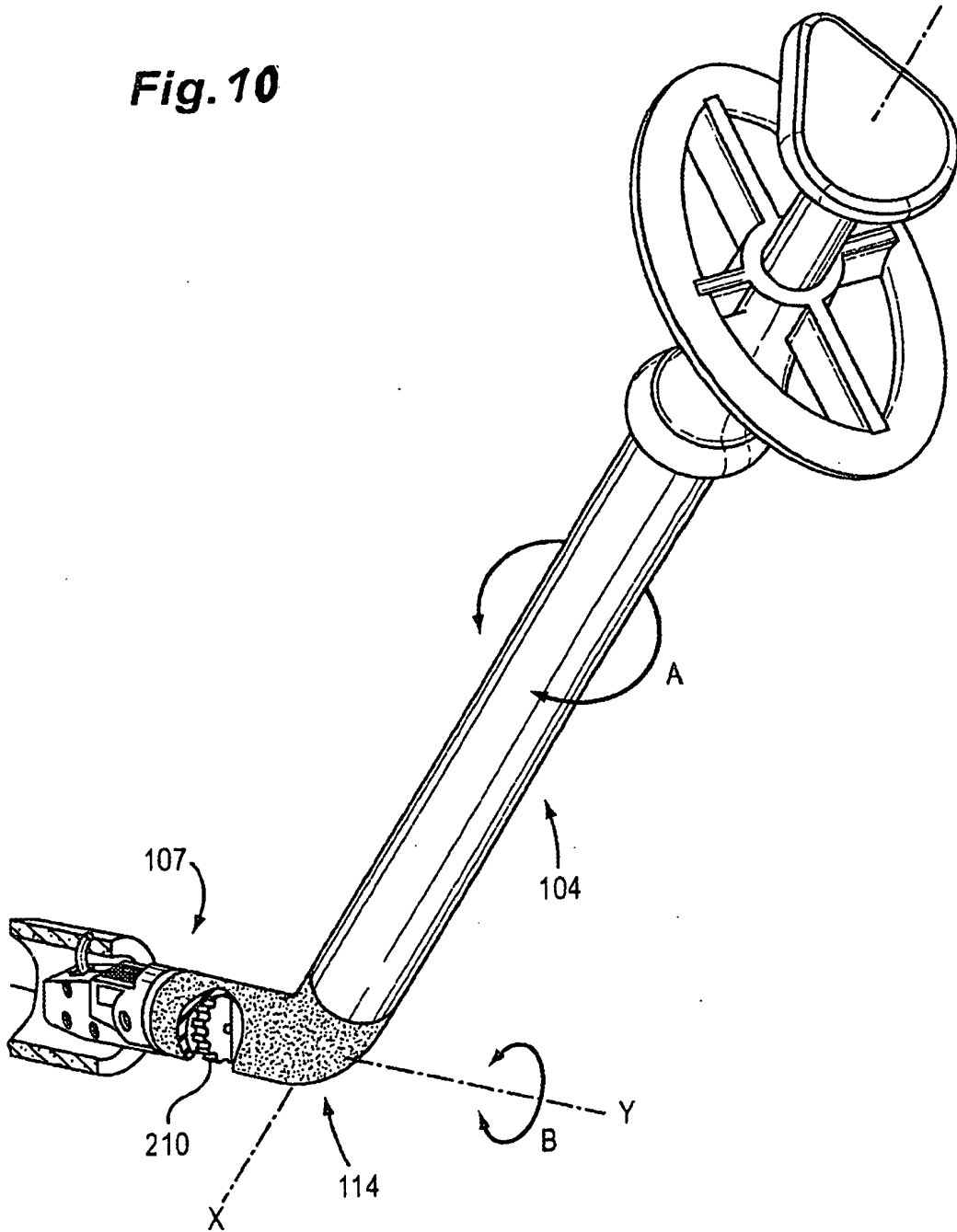

Fig.11

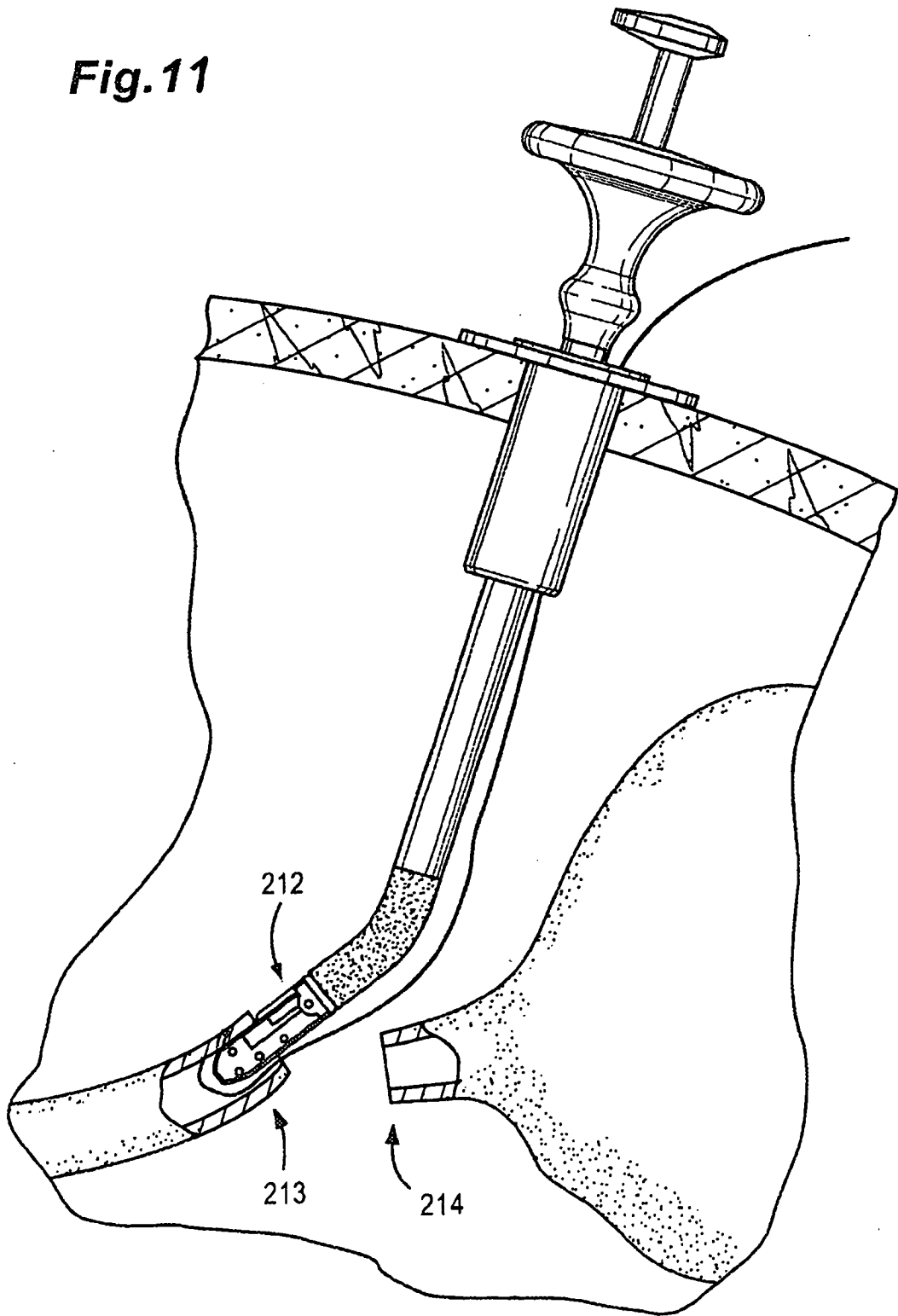
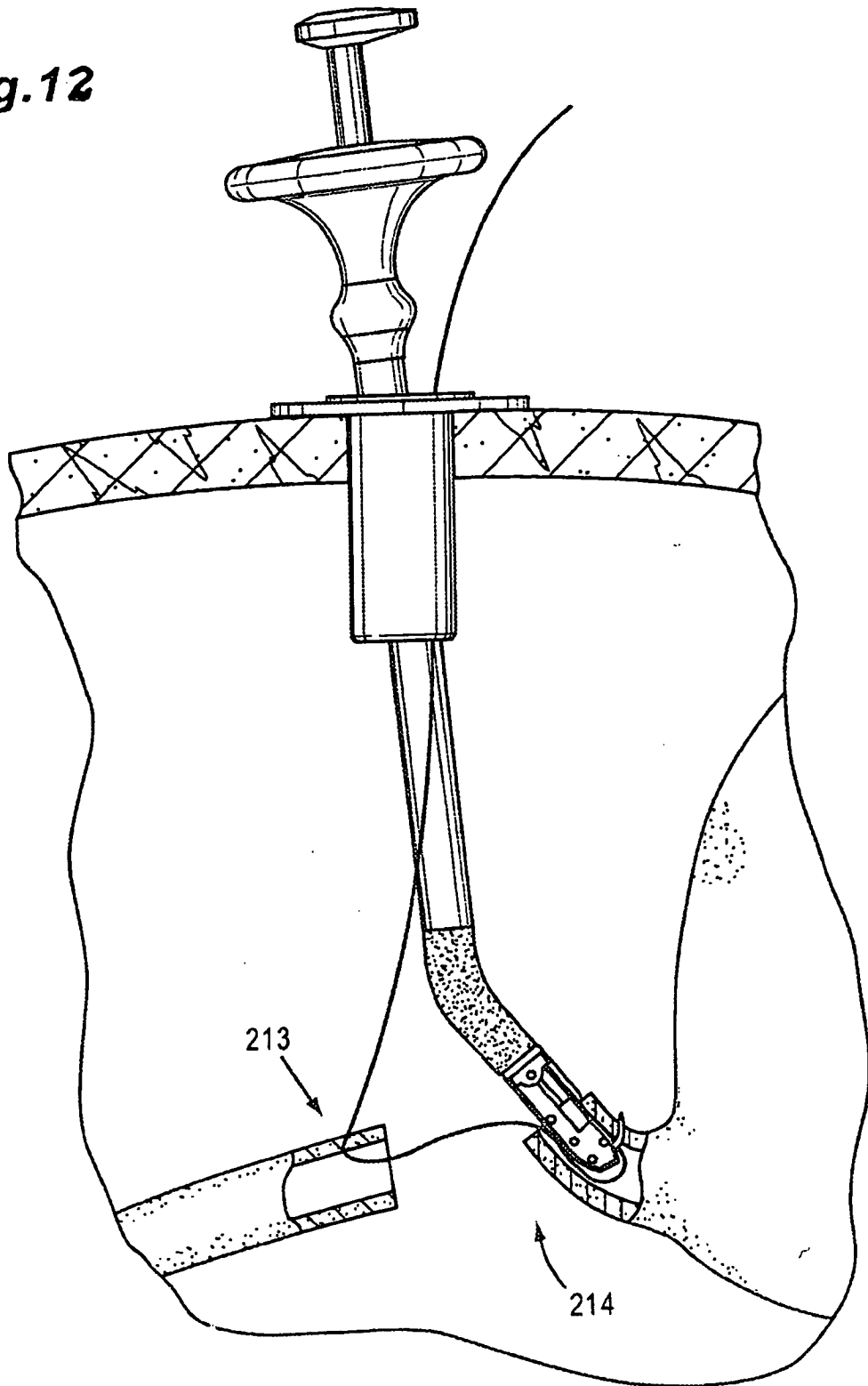

Fig.12



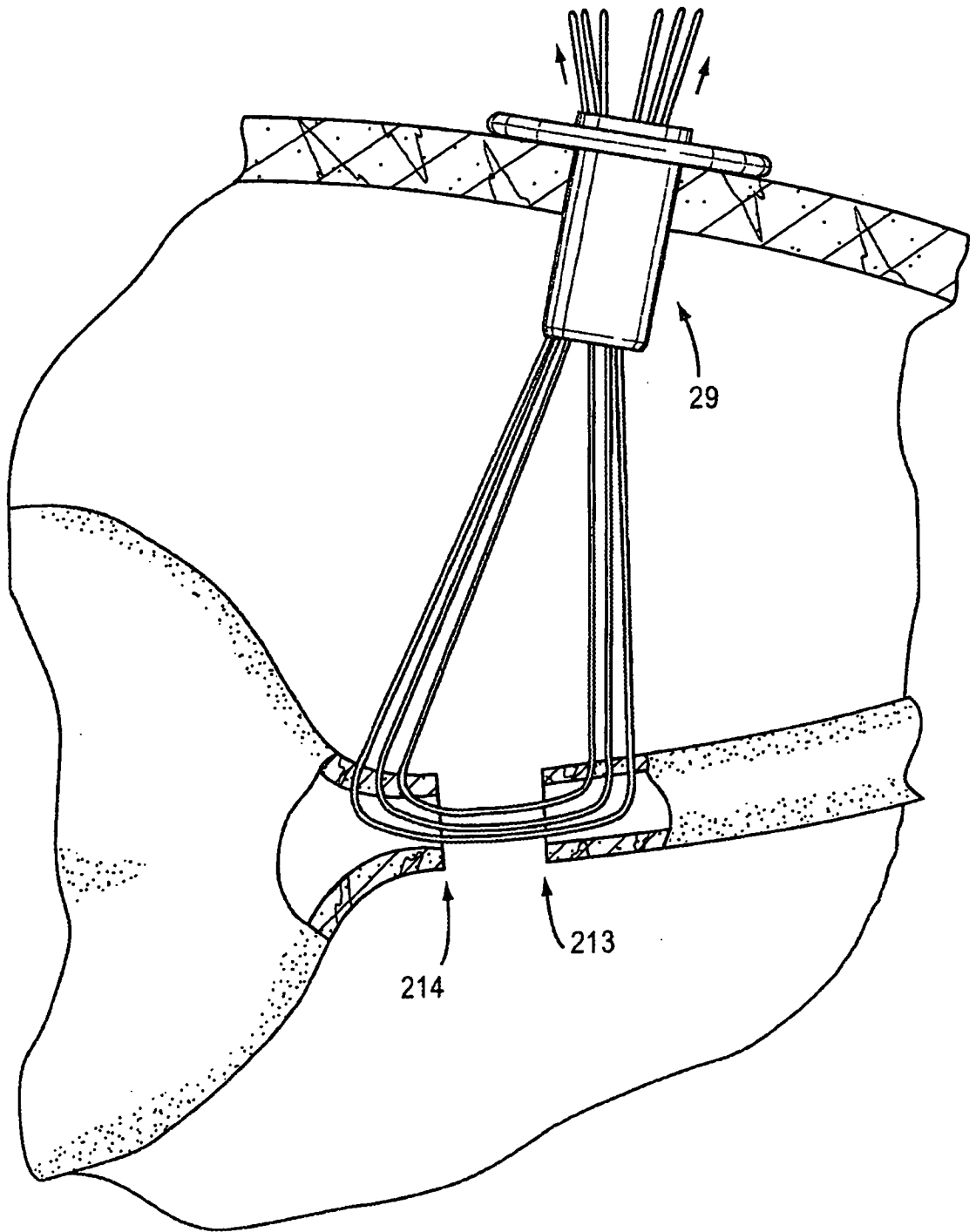

Fig.13

REFERENCES CITED IN THE DESCRIPTION

This list of references cited by the applicant is for the reader's convenience only. It does not form part of the European patent document. Even though great care has been taken in compiling the references, errors or omissions cannot be excluded and the EPO disclaims all liability in this regard.

Patent documents cited in the description

- WO 03105701 A [0005]
- US 2006041263 A1 [0006]
- US 6955643 B [0034]
- US 6936054 B [0034]
- US 5364408 A [0059]
- US 6048351 A [0059]

专利名称(译)	缝合线		
公开(公告)号	EP2083706B1	公开(公告)日	2012-02-01
申请号	EP2007863898	申请日	2007-11-05
[标]申请(专利权)人(译)	波士顿科学有限公司		
申请(专利权)人(译)	BOSTON SCIENTIFIC LIMITED		
当前申请(专利权)人(译)	BOSTON SCIENTIFIC LIMITED		
[标]发明人	CHU MICHAEL S H BIALOBRZESKI ROBERT W		
发明人	CHU, MICHAEL S. H. BIALOBRZESKI, ROBERT W.		
IPC分类号	A61B17/04 A61B17/28		
CPC分类号	A61B17/0469 A61B17/1114 A61B2017/047 A61B2017/0472 A61B2017/2905 A61B2017/2927		
优先权	60/857615 2006-11-07 US		
其他公开文献	EP2083706A1		
外部链接	Espacenet		

摘要(译)

缝合器械包括缝合头，该缝合头通过连接器构件联接到器械的细长主体构件的轴上，该连接器构件可以沿着轴的纵向轴线或者各种非中的任何一个以线性取向偏置。相对于轴的纵向轴线的线性取向。连接器构件可包括弹性材料，使得外力可施加到缝合头并使缝合头从偏置取向（例如，线性）移动到无偏置取向（例如，非线性）。一旦移除外力，连接器构件的弹性允许缝合头从无偏置取向返回到偏置取向。因此，用户可以通过在缝合头上施加或移除外力来调整器械的形状。

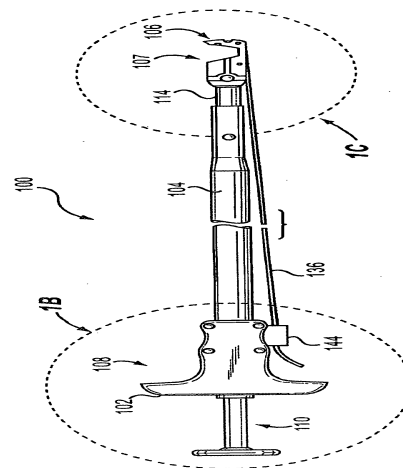

Fig. 1A