

(19)



(11)

EP 1 804 905 B1

(12)

EUROPEAN PATENT SPECIFICATION

(45) Date of publication and mention of the grant of the patent:
17.02.2016 Bulletin 2016/07

(51) Int Cl.:
A61N 1/36 (2006.01) A61B 18/14 (2006.01)
A61N 1/05 (2006.01) A61N 1/32 (2006.01)

(21) Application number: **05811851.4**

(86) International application number:
PCT/US2005/035693

(22) Date of filing: **04.10.2005**

(87) International publication number:
WO 2006/041847 (20.04.2006 Gazette 2006/16)

(54) APPARATUS FOR RENAL NEUROMODULATION

GERÄT FÜR DIE RENALE NEUROMODULATION

APPAREIL POUR LA NEUROMODULATION RENALE

(84) Designated Contracting States:
AT BE BG CH CY CZ DE DK EE ES FI FR GB GR HU IE IS IT LI LT LU LV MC NL PL PT RO SE SI SK TR

- **GELFAND, Mark**
Palo Alto, CA 94303 (US)
- **DEMARAIS, Denise**
Los Gatos, CA (US)
- **GIFFORD, Hanson, III**
Woodside, CA (US)
- **LEVIN, Howard, R.**
Teaneck, NJ 07666 (US)
- **SUTTON, Douglas**
Pacifica, CA (US)
- **CLARK, Benjamin, J.**
Redwood city, CA 94062 (US)

(30) Priority: **05.10.2004 US 616254 P**
02.11.2004 US 624793 P
13.05.2005 US 129765
25.07.2005 US 189563

(43) Date of publication of application:
11.07.2007 Bulletin 2007/28

(74) Representative: **Zimmermann & Partner**
Patentanwälte mbB
Postfach 330 920
80069 München (DE)

(60) Divisional application:
12168134.0 / 2 517 755

(73) Proprietor: **Medtronic Ardian Luxembourg S.à.r.l.**
2124 Luxembourg (LU)

(56) References cited:
WO-A-92/20291 WO-A-03/082080
US-A1- 2003 216 792 US-A1- 2004 082 978
US-B1- 6 219 577 US-B2- 6 845 267

(72) Inventors:
• **DEEM, Mark**
Mountain View, CA (US)

EP 1 804 905 B1

Note: Within nine months of the publication of the mention of the grant of the European patent in the European Patent Bulletin, any person may give notice to the European Patent Office of opposition to that patent, in accordance with the Implementing Regulations. Notice of opposition shall not be deemed to have been filed until the opposition fee has been paid. (Art. 99(1) European Patent Convention).

Description

TECHNICAL FIELD

[0001] The present invention relates to apparatus for renal neuromodulation. More particularly, the present invention relates to apparatus for achieving renal neuromodulation via a pulsed electric field and/or electroporation or electrofusion.

BACKGROUND

[0002] Congestive Heart Failure ("CHF") is a condition that occurs when the heart becomes damaged and reduces blood flow to the organs of the body. If blood flow decreases sufficiently, kidney function becomes impaired and results in fluid retention, abnormal hormone secretions and increased constriction of blood vessels. These results increase the workload of the heart and further decrease the capacity of the heart to pump blood through the kidney and circulatory system.

[0003] This reduced capacity further reduces blood flow to the kidney. It is believed that progressively decreasing perfusion of the kidney is a principal non-cardiac cause perpetuating the downward spiral of CHF. Moreover, the fluid overload and associated clinical symptoms resulting from these physiologic changes are predominant causes for excessive hospital admissions, terrible quality of life and overwhelming costs to the health care system due to CHF.

[0004] While many different diseases may initially damage the heart, once present, CHF is split into two types: Chronic CHF and Acute (or Decompensated-Chronic) CHF. Chronic Congestive Heart Failure is a longer term, slowly progressive, degenerative disease. Over years, chronic congestive heart failure leads to cardiac insufficiency. Chronic CHF is clinically categorized by the patient's ability to exercise or perform normal activities of daily living (such as defined by the New York Heart Association Functional Class). Chronic CHF patients are usually managed on an outpatient basis, typically with drugs.

[0005] Chronic CHF patients may experience an abrupt, severe deterioration in heart function, termed Acute Congestive Heart Failure, resulting in the inability of the heart to maintain sufficient blood flow and pressure to keep vital organs of the body alive. These Acute CHF deteriorations can occur when extra stress (such as an infection or excessive fluid overload) significantly increases the workload on the heart in a stable chronic CHF patient. In contrast to the stepwise downward progression of chronic CHF, a patient suffering acute CHF may deteriorate from even the earliest stages of CHF to severe hemodynamic collapse. In addition, Acute CHF can occur within hours or days following an Acute Myocardial Infarction ("AMI"), which is a sudden, irreversible injury to the heart muscle, commonly referred to as a heart attack.

[0006] As mentioned, the kidneys play a significant role in the progression of CHF, as well as in Chronic Renal Failure ("CRF"), End-Stage Renal Disease ("ESRD"), hypertension (pathologically high blood pressure) and other cardio-renal diseases. The functions of the kidney can be summarized under three broad categories: filtering blood and excreting waste products generated by the body's metabolism; regulating salt, water, electrolyte and acid-base balance; and secreting hormones to maintain vital organ blood flow. Without properly functioning kidneys, a patient will suffer water retention, reduced urine flow and an accumulation of waste toxins in the blood and body. These conditions resulting from reduced renal function or renal failure (kidney failure) are believed to increase the workload of the heart. In a CHF patient, renal failure will cause the heart to further deteriorate as the water build-up and blood toxins accumulate due to the poorly functioning kidneys and, in turn, cause the heart further harm.

[0007] The primary functional unit of the kidneys that is involved in urine formation is called the "nephron." Each kidney consists of about one million nephrons. The nephron is made up of a glomerulus and its tubules, which can be separated into a number of sections: the proximal tubule, the medullary loop (loop of Henle), and the distal tubule. Each nephron is surrounded by different types of cells that have the ability to secrete several substances and hormones (such as renin and erythropoietin). Urine is formed as a result of a complex process starting with the filtration of plasma water from blood into the glomerulus. The walls of the glomerulus are freely permeable to water and small molecules but almost impermeable to proteins and large molecules. Thus, in a healthy kidney, the filtrate is virtually free of protein and has no cellular elements. The filtered fluid that eventually becomes urine flows through the tubules. The final chemical composition of the urine is determined by the secretion into, and reabsorption of substances from, the urine required to maintain homeostasis.

[0008] Receiving about 20% of cardiac output, the two kidneys filter about 125 ml of plasma water per minute. Filtration occurs because of a pressure gradient across the glomerular membrane. The pressure in the arteries of the kidney pushes plasma water into the glomerulus causing filtration. To keep the Glomerular Filtration Rate ("GFR") relatively constant, pressure in the glomerulus is held constant by the constriction or dilatation of the afferent and efferent arterioles, the muscular walled vessels leading to and from each glomerulus.

[0009] In a CHF patient, the heart will progressively fail, and blood flow and pressure will drop in the patient's circulatory system. During acute heart failure, short-term compensations serve to maintain perfusion to critical organs, notably the brain and the heart that cannot survive prolonged reduction in blood flow. However, these same responses that initially aid survival during acute heart failure become deleterious during chronic heart failure.

[0010] A combination of complex mechanisms contrib-

ute to deleterious fluid overload in CHF. As the heart fails and blood pressure drops, the kidneys cannot function and become impaired due to insufficient blood pressure for perfusion. This impairment in renal function ultimately leads to the decrease in urine output. Without sufficient urine output, the body retains fluids, and the resulting fluid overload causes peripheral edema (swelling of the legs), shortness of breath (due to fluid in the lungs), and fluid retention in the abdomen, among other undesirable conditions in the patient.

[0011] In addition, the decrease in cardiac output leads to reduced renal blood flow, increased neurohormonal stimulus, and release of the hormone renin from the juxtaglomerular apparatus of the kidney. This results in avid retention of sodium and, thus, volume expansion. Increased renin results in the formation of angiotensin, a potent vasoconstrictor. Heart failure and the resulting reduction in blood pressure also reduce the blood flow and perfusion pressure through organs in the body other than the kidneys. As they suffer reduced blood pressure, these organs may become hypoxic, resulting in a metabolic acidosis that reduces the effectiveness of pharmacological therapy and increases a risk of sudden death.

[0012] This spiral of deterioration that physicians observe in heart failure patients is believed to be mediated, at least in part, by activation of a subtle interaction between heart function and kidney function, known as the renin-angiotensin system. Disturbances in the heart's pumping function results in decreased cardiac output and diminished blood flow. The kidneys respond to the diminished blood flow as though the total blood volume was decreased, when in fact the measured volume is normal or even increased. This leads to fluid retention by the kidneys and formation of edema, thereby causing the fluid overload and increased stress on the heart

[0013] Systemically, CHF is associated with an abnormally elevated peripheral vascular resistance and is dominated by alterations of the circulation resulting from an intense disturbance of sympathetic nervous system function. Increased activity of the sympathetic nervous system promotes a downward vicious cycle of increased arterial vasoconstriction (increased resistance of vessels to blood flow) followed by a further reduction of cardiac output, causing even more diminished blood flow to the vital organs.

[0014] In CHF via the previously explained mechanism of vasoconstriction, the heart and circulatory system dramatically reduce blood flow to the kidneys. During CHF, the kidneys receive a command from higher neural centers via neural pathways and hormonal messengers to retain fluid and sodium in the body. In response to stress on the heart, the neural centers command the kidneys to reduce their filtering functions. While in the short term, these commands can be beneficial, if these commands continue over hours and days they can jeopardize the person's life or make the person dependent on artificial kidney for life by causing the kidneys to cease functioning.

[0015] When the kidneys do not fully filter the blood, a huge amount of fluid is retained in the body, which results in bloating (fluid retention in tissues) and increases the workload of the heart. Fluid can penetrate into the lungs, and the patient becomes short of breath. This odd and self-destructive phenomenon is most likely explained by the effects of normal compensatory mechanisms of the body that improperly perceive the chronically low blood pressure of CHF as a sign of temporary disturbance, such as bleeding.

[0016] In an acute situation, the body tries to protect its most vital organs, the brain and the heart, from the hazards of oxygen deprivation. Commands are issued via neural and hormonal pathways and messengers. These commands are directed toward the goal of maintaining blood pressure to the brain and heart, which are treated by the body as the most vital organs. The brain and heart cannot sustain low perfusion for any substantial period of time. A stroke or a cardiac arrest will result if the blood pressure to these organs is reduced to unacceptable levels. Other organs, such as the kidneys, can withstand somewhat longer periods of ischemia without suffering long-term damage. Accordingly, the body sacrifices blood supply to these other organs in favor of the brain and the heart.

[0017] The hemodynamic impairment resulting from CHF activates several neurohormonal systems, such as the renin-angiotensin and aldosterone system, sympatho-adrenal system and vasopressin release. As the kidneys suffer from increased renal vasoconstriction, the GFR drops, and the sodium load in the circulatory system increases. Simultaneously, more renin is liberated from the juxtaglomerular of the kidney. The combined effects of reduced kidney functioning include reduced glomerular sodium load, an aldosterone-mediated increase in tubular reabsorption of sodium, and retention in the body of sodium and water. These effects lead to several signs and symptoms of the CHF condition, including an enlarged heart, increased systolic wall stress, an increased myocardial oxygen demand, and the formation of edema on the basis of fluid and sodium retention in the kidney. Accordingly, sustained reduction in renal blood flow and vasoconstriction is directly responsible for causing the fluid retention associated with CHF.

[0018] CHF is progressive, and as of now, not curable. The limitations of drug therapy and its inability to reverse or even arrest the deterioration of CHF patients are clear. Surgical therapies are effective in some cases, but limited to the end-stage patient population because of the associated risk and cost. Furthermore, the dramatic role played by kidneys in the deterioration of CHF patients is not adequately addressed by current surgical therapies.

[0019] The autonomic nervous system is recognized as an important pathway for control signals that are responsible for the regulation of body functions critical for maintaining vascular fluid balance and blood pressure. The autonomic nervous system conducts information in the form of signals from the body's biologic sensors such

as baroreceptors (responding to pressure and volume of blood) and chemoreceptors (responding to chemical composition of blood) to the central nervous system via its sensory fibers. It also conducts command signals from the central nervous system that control the various innervated components of the vascular system via its motor fibers.

[0020] Experience with human kidney transplantation provided early evidence of the role of the nervous system in kidney function. It was noted that after transplant, when all the kidney nerves were totally severed, the kidney increased the excretion of water and sodium. This phenomenon was also observed in animals when the renal nerves were cut or chemically destroyed. The phenomenon was called "denervation diuresis" since the denervation acted on a kidney similar to a diuretic medication. Later the "denervation diuresis" was found to be associated with vasodilatation of the renal arterial system that led to increased blood flow through the kidney. This observation was confirmed by the observation in animals that reducing blood pressure supplying the kidneys reversed the "denervation diuresis."

[0021] It was also observed that after several months passed after the transplant surgery in successful cases, the "denervation diuresis" in transplant recipients stopped and the kidney function returned to normal. Originally, it was believed that the "renal diuresis" was a transient phenomenon and that the nerves conducting signals from the central nervous system to the kidney were not essential to kidney function. Later discoveries suggested that the renal nerves had a profound ability to regenerate and that the reversal of "denervation diuresis" could be attributed to the growth of new nerve fibers supplying the kidneys with necessary stimuli.

[0022] Another body of research focused on the role of the neural control of secretion of the hormone renin by the kidney. As was discussed previously, renin is a hormone responsible for the "vicious cycle" of vasoconstriction and water and sodium retention in heart failure patients. It was demonstrated that an increase or decrease in renal sympathetic nerve activity produced parallel increases and decreases in the renin secretion rate by the kidney, respectively.

[0023] In summary, it is known from clinical experience and the large body of animal research that an increase in renal sympathetic nerve activity leads to vasoconstriction of blood vessels supplying the kidney, decreased renal blood flow, decreased removal of water and sodium from the body, and increased renin secretion. It is also known that reduction of sympathetic renal nerve activity, e.g., via denervation, may reverse these processes.

[0024] It has been established in animal models that the heart failure condition results in abnormally high sympathetic stimulation of the kidney. This phenomenon was traced back to the sensory nerves conducting signals from baroreceptors to the central nervous system. Baroreceptors are present in the different locations of the vascular system. Powerful relationships exist between

baroreceptors in the carotid arteries (supplying the brain with arterial blood) and sympathetic nervous stimulus to the kidneys. When arterial blood pressure was suddenly reduced in experimental animals with heart failure, sympathetic tone increased. Nevertheless, the normal baroreflex likely is not solely responsible for elevated renal nerve activity in chronic CHF patients. If exposed to a reduced level of arterial pressure for a prolonged time, baroreceptors normally "reset," i.e., return to a baseline level of activity, until a new disturbance is introduced. Therefore, it is believed that in chronic CHF patients, the components of the autonomic-nervous system responsible for the control of blood pressure and the neural control of the kidney function become abnormal. The exact mechanisms that cause this abnormality are not fully understood, but its effects on the overall condition of the CHF patients are profoundly negative.

[0025] End-Stage Renal Disease is another condition at least partially controlled by renal neural activity. There has been a dramatic increase in patients with ESRD due to diabetic nephropathy, chronic glomerulonephritis and uncontrolled hypertension. Chronic Renal Failure slowly progresses to ESRD. CRF represents a critical period in the evolution of ESRD. The signs and symptoms of CRF are initially minor, but over the course of 2-5 years, become progressive and irreversible. While some progress has been made in combating the progression to, and complications of, ESRD, the clinical benefits of existing interventions remain limited.

[0026] It has been known for several decades that renal diseases of diverse etiology (hypotension, infection, trauma, autoimmune disease, etc.) can lead to the syndrome of CRF characterized by systemic hypertension, proteinuria (excess protein filtered from the blood into the urine) and a progressive decline in GFR ultimately resulting in ESRD. These observations suggest that CRF progresses via a common pathway of mechanisms and that therapeutic interventions inhibiting this common pathway may be successful in slowing the rate of progression of CRF irrespective of the initiating cause.

[0027] To start the vicious cycle of CRF, an initial insult to the kidney causes loss of some nephrons. To maintain normal GFR, there is an activation of compensatory renal and systemic mechanisms resulting in a state of hyperfiltration in the remaining nephrons. Eventually, however, the increasing numbers of nephrons "overworked" and damaged by hyperfiltration are lost. At some point, a sufficient number of nephrons are lost so that normal GFR can no longer be maintained. These pathologic changes of CRF produce worsening systemic hypertension, thus high glomerular pressure and increased hyperfiltration. Increased glomerular hyperfiltration and permeability in CRF pushes an increased amount of protein from the blood, across the glomerulus and into the renal tubules. This protein is directly toxic to the tubules and leads to further loss of nephrons, increasing the rate of progression of CRF. This vicious cycle of CRF continues as the GFR drops with loss of additional nephrons leading to

further hyperfiltration and eventually to ESRD requiring dialysis. Clinically, hypertension and excess protein filtration have been shown to be two major determining factors in the rate of progression of CRF to ESRD.

[0028] Though previously clinically known, it was not until the 1980s that the physiologic link between hypertension, proteinuria, nephron loss and CRF was identified. In the 1990s the role of sympathetic nervous system activity was elucidated. Afferent signals arising from the damaged kidneys due to the activation of mechanoreceptors and chemoreceptors stimulate areas of the brain responsible for blood pressure control. In response, the brain increases sympathetic stimulation on the systemic level, resulting in increased blood pressure primarily through vasoconstriction of blood vessels. When elevated sympathetic stimulation reaches the kidney via the efferent sympathetic nerve fibers, it produces major deleterious effects in two forms. The kidneys are damaged by direct renal toxicity from the release of sympathetic neurotransmitters (such as norepinephrine) in the kidneys independent of the hypertension. Furthermore, secretion of renin that activates Angiotensin II is increased, which increases systemic vasoconstriction and exacerbates hypertension.

[0029] Over time, damage to the kidneys leads to a further increase of afferent sympathetic signals from the kidney to the brain. Elevated Angiotensin II further facilitates internal renal release of neurotransmitters. The feedback loop is therefore closed, which accelerates deterioration of the kidneys.

[0030] Document US-B-6 219 577 discloses the most relevant prior art.

[0031] In view of the foregoing, it would be desirable to provide methods and apparatus for the treatment of congestive heart failure, renal disease, hypertension and/or other cardio-renal diseases via renal neuromodulation and/or denervation.

SUMMARY

[0032] The invention is defined in claim 1.

[0033] The present disclosure provides methods and apparatus for renal neuromodulation (e.g., denervation) using a pulsed electric field (PEF). Several aspects of the disclosure apply a pulsed electric field to effectuate electroporation and/or electrofusion in renal nerves, other neural fibers that contribute to renal neural function, or other neural features. Several embodiments of the disclosure are extravascular devices for inducing renal neuromodulation. The apparatus and methods described herein may utilize any suitable electrical signal or field parameters that achieve neuromodulation, including denervation, and/or otherwise create an electroporative and/or electrofusion effect. For example, the electrical signal may incorporate a nanosecond pulsed electric field (nsPEF) and/or a PEF for effectuating electroporation. One specific embodiment comprises applying a first course of PEF electroporation followed by a second

course of nsPEF electroporation to induce apoptosis in any cells left intact after the PEF treatment, or vice versa. An alternative embodiment comprises fusing nerve cells by applying a PEF in a manner that is expected to reduce or eliminate the ability of the nerves to conduct electrical impulses. When the methods and apparatus are applied to renal nerves and/or other neural fibers that contribute to renal neural functions, the inventors of the present invention believe that urine output will increase, renin levels will decrease, urinary sodium excretion will increase and/or blood pressure will be controlled in a manner that will prevent or treat CHF, hypertension, renal system diseases, and other renal anomalies.

[0034] Several aspects of particular embodiments can achieve such results by selecting suitable parameters for the PEFs and/or nsPEFs. Pulsed electric field parameters can include, but are not limited to, field strength, pulse width, the shape of the pulse, the number of pulses and/or the interval between pulses (e.g., duty cycle). Suitable field strengths include, for example, strengths of up to about 10,000 V/cm. Suitable pulse widths include, for example, widths of up to about 1 second. Suitable shapes of the pulse waveform include, for example, AC waveforms, sinusoidal waves, cosine waves, combinations of sine and cosine waves, DC waveforms, DC-shifted AC waveforms, RF waveforms, square waves, trapezoidal waves, exponentially-decaying waves, combinations thereof, etc. Suitable numbers of pulses include, for example, at least one pulse. Suitable pulse intervals include, for example, intervals less than about 10 seconds. Any combination of these parameters may be utilized as desired. These parameters are provided for the sake of illustration and should in no way be considered limiting. Additional and alternative waveform parameters will be apparent.

[0035] Several embodiments are directed to extravascular systems for providing long-lasting denervation to minimize acute myocardial infarct ("AMI") expansion and for helping to prevent the onset of morphological changes that are affiliated with congestive heart failure. For example, one embodiment of the disclosure comprises treating a patient for an infarction, e.g., via coronary angioplasty and/or stenting, and performing an extravascular pulsed electric field renal denervation procedure under, for example, Computed Tomography ("CT") guidance. PEF therapy can, for example, be delivered in a separate session soon after the AMI has been stabilized. Renal neuromodulation also may be used as an adjunctive therapy to renal surgical procedures. In these embodiments, the anticipated increase in urine output, decrease in renin levels, increase in urinary sodium excretion and/or control of blood pressure provided by the renal PEF therapy is expected to reduce the load on the heart to inhibit expansion of the infarct and prevent CHF.

[0036] Several embodiments of extravascular pulsed electric field systems described herein may denervate or reduce the activity of the renal nervous supply immediately post-infarct, or at any time thereafter, without leav-

ing behind a permanent implant in the patient. These embodiments are expected to increase urine output, decrease renin levels, increase urinary sodium excretion and/or control blood pressure for a period of several months during which the patient's heart can heal. If it is determined that repeat and/or chronic neuromodulation would be beneficial after this period of healing, renal PEF treatment can be repeated as needed and/or a permanent implant may be provided.

[0037] In addition to efficaciously treating AMI, several embodiments of systems described herein are also expected to treat CHF, hypertension, renal failure, and other renal or cardio-renal diseases influenced or affected by increased renal sympathetic nervous activity. For example, the systems may be used to treat CHF at any time by extravascularly advancing the PEF system to a treatment site, for example, under CT-guidance. Once properly positioned, a PEF therapy may be delivered to the treatment site. This may, for example, modify a level of fluid offload.

[0038] The use of PEF therapy for the treatment of CHF, hypertension, end-stage renal disease and other cardio-renal diseases is described in detail hereinafter in several different extravascular system embodiments. The systems can be introduced into the area of the renal neural tissue under, for example, CT, ultrasonic, angiographic or laparoscopic guidance, or the systems can be surgically implanted using a combination of these or other techniques. The various elements of the system may be placed in a single operative session, or in two or more staged sessions. For instance, a percutaneous therapy might be conducted under CT or CT/angiographic guidance. For a partially or fully implantable system, a combination of CT, angiographic or laparoscopic implantation of leads and nerve contact elements might be paired with a surgical implantation of the subcutaneous contact element or control unit. The systems may be employed unilaterally or bilaterally as desired for the intended clinical effect. The systems can be used to modulate efferent or afferent nerve signals, as well as combinations of efferent and afferent signals.

[0039] In one variation, PEF therapy is delivered at a treatment site to create a non-thermal nerve block, reduce neural signaling, or otherwise modulate neural activity. Alternatively or additionally, cooling, cryogenic, pulsed RF, thermal RF, thermal or non-thermal microwave, focused or unfocused ultrasound, thermal or non-thermal DC, as well as any combination thereof, may be employed to reduce or otherwise control neural signaling.

[0040] Several embodiments of the PEF systems may completely block or denervate the target neural structures, or the PEF systems may otherwise modulate the renal nervous activity. As opposed to a full neural blockade such as denervation, other neuromodulation produces a less-than-complete change in the level of renal nervous activity between the kidney(s) and the rest of the body. Accordingly, varying the pulsed electric field parameters will produce different effects on the nervous

activity.

[0041] Any of the embodiments of the present disclosure described herein optionally may be configured for infusing agents into the treatment area before, during or after energy application. The infused agents may create a working space for introduction of PEF system elements, such as electrodes. Additionally or alternatively, the infused agents may be selected to enhance or modify the neuromodulatory effect of the energy application. The agents also may protect or temporarily displace non-target cells, and/or facilitate visualization.

[0042] Several embodiments of the present disclosure may comprise detectors or other elements that facilitate identification of locations for treatment and/or that measure or confirm the success of treatment. For example, temporary nerve-block agents, such as lidocaine, bupivacaine or the like, might be infused through a percutaneous needle injection or through an infusion port built into a partially or fully implantable system to ensure proper location of neural contact elements prior to delivering PEF therapy. Alternatively or additionally, the system can be configured to also deliver stimulation waveforms and monitor physiological parameters known to respond to stimulation of the renal nerves. Based on the results of the monitored parameters, the system can determine the location of renal nerves and/or whether denervation has occurred. Detectors for monitoring of such physiological responses include, for example, Doppler elements, thermocouples, pressure sensors, and imaging modalities (e.g., fluoroscopy, intravascular ultrasound, etc.). Alternatively, electroporation may be monitored directly using, for example, Electrical Impedance Tomography ("EIT") or other electrical impedance measurements or sensors. Additional monitoring techniques and elements will be apparent. Such detector(s) may be integrated with the PEF systems or they may be separate elements.

[0043] In some embodiments, stimulation of the nerve plexus may be utilized to determine whether repeat therapy is required. For example, stimulation may be used to elicit a pain response from the renal nerves. If the patient senses this stimulation, then it is apparent that nerve conduction has returned, and repeat therapy is warranted. This method optionally may be built into any of the systems described hereinafter - percutaneous, partially implantable or fully implantable.

[0044] Still other specific embodiments include electrodes configured to align the electric field with the longer dimension of the target cells. For instance, nerve cells tend to be elongate structures with lengths that greatly exceed their lateral dimensions (e.g., diameter). By aligning an electric field so that the directionality of field propagation preferentially affects the longitudinal aspect of the cell rather than the lateral aspect of the cell, it is expected that lower field strengths can be used to kill or disable target cells. This is expected to conserve the battery life of implantable devices, reduce collateral effects on adjacent structures, and otherwise enhance the ability to modulate the neural activity of target cells.

[0045] Other embodiments of the disclosure are directed to applications in which the longitudinal dimensions of cells in tissues overlying or underlying the nerve are transverse (e.g., orthogonal or otherwise at an angle) with respect to the longitudinal direction of the nerve cells. Another aspect of these embodiments is to align the directionality of the PEF such that the field aligns with the longer dimensions of the target cells and the shorter dimensions of the non-target cells. More specifically, arterial smooth muscle cells are typically elongate cells which surround the arterial circumference in a generally spiraling orientation so that their longer dimensions are circumferential rather than running longitudinally along the artery. Nerves of the renal plexus, on the other hand, run along the outside of the artery generally in the longitudinal direction of the artery. Therefore, applying a PEF which is generally aligned with the longitudinal direction of the artery is expected to preferentially cause electroporation in the target nerve cells without affecting at least some of the non-target arterial smooth muscle cells to the same degree. This may enable preferential denervation of nerve cells (target cells) in the adventitia or periarterial region without affecting the smooth muscle cells of the vessel to an undesirable extent.

[0046] It should be understood that the PEF systems described in this application are not necessarily required to make physical contact with the tissue or neural fibers to be treated. Electrical energy, such as thermal RF energy and non-thermal pulsed RF, may be conducted to tissue to be treated from a short distance away from the tissue itself. Thus, it may be appreciated that "nerve contact" comprises both physical contact of a system element with the nerve, as well as electrical contact alone without physical contact, or as a combination of the two.

[0047] In one embodiment of an extravascular pulsed electric field system, a laparoscopic or percutaneous system is utilized. For example, a percutaneous probe may be inserted in proximity to the track of the renal neural supply along the renal artery or vein and/or within the Gerota's fascia, under, e.g., CT or radiographic guidance. Once properly positioned, pulsed electric field therapy may be applied to target neural fibers via the probe, after which the probe may be removed from the patient to conclude the procedure.

[0048] It is expected that such therapy would reduce or alleviate clinical symptoms of CHF, hypertension, renal disease and/or other cardio-renal diseases, for several months (e.g., potentially up to six months or more). This time period might be sufficient to allow the body to heal, for example, this period might reduce a risk of CHF onset after an acute myocardial infarction, thereby alleviating a need for subsequent re-treatment. Alternatively, as symptoms reoccur, or at regularly scheduled intervals, the patient might return to the physician or self-administer a repeat therapy. As another alternative, repeat therapy might be fully automated.

[0049] The need for a repeat therapy optionally might be predicted by monitoring of physiologic parameters,

for example, by monitoring specific neurohormones (plasma renin levels, etc.) that are indicative of increased sympathetic nervous activity. Alternatively, provocative maneuvers known to increase sympathetic nervous activity, such as head-out water immersion testing, may be conducted to determine the need for repeat therapy.

[0050] In addition or as an alternative to laparoscopic or percutaneous PEF systems, partially implantable PEF systems may be utilized. For example, an external control box may connect through or across the patient's skin to a subcutaneous element. Leads may be tunneled from the subcutaneous element to a nerve cuff or a nerve contact element in proximity to Gerota's fascia, the renal artery, vein and/or hilum. PEF therapy may be conducted from the external control box across or through the skin to the subcutaneous element and to the nerve cuff or nerve contact element to modulate neural fibers that contribute to renal function.

[0051] The PEF may be transmitted across or through the skin via direct methods, such as needles or trocars, or via indirect methods such as transcutaneous energy transfer ("TET") systems. TET systems are used clinically to recharge batteries in rechargeable implantable stimulation or pacing devices, left ventricular assist devices, etc. In one TET embodiment of the present disclosure the subcutaneous system may have a receiving coil to gather transmitted energy, a capacitor or temporary storage device to collect the charge, control electronics to create a waveform, as well as leads and nerve electrode(s) to deliver the energy waveform to the renal nerves.

[0052] In another TET embodiment, a PEF signal itself may be transmitted telemetrically through the skin to a subcutaneous receiving element. Passive leads connecting the subcutaneous receiving element to nerve electrodes may conduct the signal to the nerves for treatment, thereby eliminating a need for a receiving battery or capacitor, as well as signal processing circuitry, in the implanted portion of the PEF system.

[0053] In other partially implanted embodiments, the implanted subcutaneous elements may be entirely passive. The subcutaneous elements may include an implantable electrical connector that is easily accessible via a simple needle, leads to the nerve electrodes, and the nerve electrodes themselves. The implanted system might also incorporate an infusion lumen to allow drugs to be introduced from a subcutaneous port to the treatment area. A control box, a lead and a transcutaneous needle or trocar electrical connector may be disposed external to the patient.

[0054] In addition or as an alternative to non-implanted PEF systems, or partially implantable PEF systems, fully implantable PEF systems may be utilized. An implantable control housing containing signal generation circuitry and energy supply circuitry may be attached to leads which are tunneled to a renal nerve cuff or renal nerve contact electrodes. Power may be provided by a battery included with the implantable housing. The battery may, for ex-

ample, require surgical replacement after a period of months or years, or may be rechargeable via a TET system. When therapy is required, a PEF signal is applied to the nerves using the contact electrodes, with the control housing serving as the return electrode.

[0055] The need for repeat therapy may be tested by the implantable system. For example, a lower-frequency stimulation signal may be applied to the nerves periodically by the system. When the nerve has returned toward baseline function, the test signal would be felt by the patient, and the system then would be instructed to apply another course of PEF therapy. This repeat treatment optionally might be patient or physician initiated. If the patient feels the test signal, the patient or physician might operate the implantable system via electronic telemetry, magnetic switching or other means to apply the required therapeutic PEF.

[0056] Alternatively, the system could be programmed in an open-loop fashion to apply another PEF treatment periodically, for example, once every six months. In still another embodiment, monitoring methods that assess parameters or symptoms of the patient's clinical status may be used to determine the need for repeat therapy.

[0057] The nerve contact elements of any of the percutaneous, partially implantable or fully implantable systems may comprise a variety of embodiments. For instance, the implanted elements might be in the form of a cuff, basket, cupped contact, fan-shaped contact, space-filling contact, spiral contact or the like. Implantable nerve contact elements may incorporate elements that facilitate anchoring and/or tissue in-growth. For instance, fabric or implantable materials such as Dacron or ePTFE might be incorporated into the design of the contact elements to facilitate in-growth into areas of the device that would help anchor the system in place, but repel tissue in-growth in undesired areas, such as the electrical contacts. Similarly, coatings, material treatments, drug coatings or drug elution might be used alone or in combination to facilitate or retard tissue in-growth into various segments of the implanted system as desired.

BRIEF DESCRIPTION OF THE DRAWINGS

[0058] Several embodiments of the present disclosure will be apparent upon consideration of the following detailed description, taken in conjunction with the accompanying drawings, in which like reference characters refer to like parts throughout, and in which:

Figure 1 is a schematic view illustrating human renal anatomy.

Figure 2 is a schematic detail view showing the location of the renal nerves relative to the renal artery.

Figures 3A and 3B are schematic side- and end-views, respectively, illustrating a direction of electri-

cal current flow for selectively affecting renal nerves.

Figure 4 is a schematic view illustrating a percutaneous or laparoscopic method and apparatus for renal neuromodulation.

Figure 5 is a schematic view illustrating another percutaneous or laparoscopic method and apparatus for renal neuromodulation comprising a spreading electrode for at least partially surrounding renal vasculature.

Figure 6 is a schematic view illustrating a percutaneous or laparoscopic method and apparatus for renal neuromodulation comprising a spiral electrode configured to surround renal vasculature.

Figure 7 is a schematic view illustrating a percutaneous or laparoscopic method and apparatus for renal neuromodulation comprising a ring electrode configured to at least partially surround renal vasculature.

Figure 8 is a schematic view illustrating another percutaneous or laparoscopic method and apparatus for renal neuromodulation comprising a spreading electrode configured for positioning near the renal hilum.

Figure 9 is a schematic view illustrating a percutaneous or laparoscopic method and apparatus for renal neuromodulation comprising a space-occupying electrode configured for positioning near the renal hilum.

Figure 10 is a schematic view illustrating a percutaneous or laparoscopic method and apparatus for accessing Gerota's fascia.

Figures 11A and 11B are schematic views illustrating methods and apparatus for mechanically anchoring a delivery system or electrode within Gerota's fascia.

Figure 12 is a schematic view illustrating a method and apparatus for positioning electrodes along a patient's renal artery within an annular space between the artery and Gerota's fascia in order to achieve renal neuromodulation.

Figures 13A-13C are schematic detail views of various embodiments of the electrodes of Figure 12.

Figures 14A-14C are schematic views and a detail view illustrating another method and apparatus for positioning electrodes along the patient's renal artery.

Figures 15A and 15B are a schematic view and a

detail view illustrating yet another method and apparatus for positioning electrodes.

Figure 16 is a schematic view illustrating still another method and apparatus for positioning electrodes along the patient's renal artery.

Figures 17A and 17B are schematic views illustrating another method and apparatus for positioning electrodes along the patient's renal artery.

Figure 18 is a schematic view illustrating a method and apparatus for positioning implantable electrodes along the patient's renal artery.

Figures 19A and 19B are schematic views illustrating methods and apparatus for renal neuromodulation via partially implantable systems.

Figure 20 is a schematic view illustrating a method and apparatus for renal neuromodulation via a fully implantable system.

Figures 21A and 21B are schematic views illustrating a method and apparatus for positioning electrodes relative to a renal neural structure in accordance with another embodiment of the disclosure.

Figures 22A and 22B are schematic views illustrating a method and apparatus for positioning electrodes relative to a patient's renal neural structure in accordance with still another embodiment of the disclosure.

Figure 23 is a schematic view illustrating a method and apparatus for positioning electrodes relative to a patient's renal neural structure in accordance with yet another embodiment of the disclosure.

A. Overview

[0059] The present disclosure relates to methods and apparatus for renal neuromodulation and/or other neuromodulation. More particularly, the present disclosure relates to methods and apparatus for renal neuromodulation using a pulsed electric field to effectuate electroporation or electrofusion. used herein, electroporation and lectropermeabilization are methods of manipulating the cell membrane or intracellular apparatus. For example, short high-energy pulses cause pores to open in cell membranes. The extent of porosity in the cell membrane (e.g., size and number of pores) and the duration of the pores (e.g., temporary or permanent) are a function of the field strength, pulse width, duty cycle, field orientation, cell type and other parameters. In general, pores will generally close spontaneously upon termination of lower strength fields or shorter pulse widths (herein defined as "reversible electroporation"). Each cell type has

a critical threshold above which pores do not close such that pore formation is no longer reversible; this result is defined as "irreversible electroporation," "irreversible breakdown" or "irreversible damage." At this point, the cell membrane ruptures and/or irreversible chemical imbalances caused by the high porosity occur. Such high porosity can be the result of a single large hole and/or a plurality of smaller holes. Certain types of electroporation energy parameters also appropriate for use in renal neuromodulation are high voltage pulses with a duration in the submicrosecond range (nanosecond pulsed electric fields, or nsPEF) which may leave the cellular membrane intact, but alter the intracellular apparatus or function of the cell in ways which cause cell death or disruption. Certain applications of nsPEF have been shown to cause cell death by inducing apoptosis, or programmed cell death, rather than acute cell death. Also, the term "comprising" is used throughout to mean including at least the recited feature such that any greater number of the same feature and/or additional types features are not precluded.

[0060] Several embodiments of the present disclosure provide extravascular devices or systems for inducing renal neuromodulation, such as a temporary change in target nerves that dissipates over time, continuous control over neural function, and/or denervation. The apparatus and methods described herein may utilize any suitable electrical signal or field parameters, e.g., any electric field, that will achieve the desired neuromodulation (e.g., electroporative effect). To better understand the structures of the extravascular devices and the methods of using these devices for neuromodulation, it is useful to understand the renal anatomy in humans.

B. Selected Embodiments of Methods for Neuromodulation

[0061] With reference now to Figure 1, the human renal anatomy includes kidneys K that are supplied with oxygenated blood by renal arteries RA, which are connected to the heart by the abdominal aorta AA. Deoxygenated blood flows from the kidneys to the heart via renal veins RV and the inferior vena cava IVC. Figure 2 illustrates a portion of the renal anatomy in greater detail. More specifically, the renal anatomy also includes renal nerves RN extending longitudinally along the lengthwise dimension L of renal artery RA generally within the adventitia of the artery. The renal artery RA has smooth muscle cells SMC that surround the arterial circumference and spiral around the angular axis 0 of the artery. The smooth muscle cells of the renal artery accordingly have a lengthwise or longer dimension extending transverse (i.e., non-parallel) to the lengthwise dimension of the renal artery. The misalignment of the lengthwise dimensions of the renal nerves and the smooth muscle cells is defined as "cellular misalignment."

[0062] Referring to Figure 3, the cellular misalignment of the renal nerves and the smooth muscle cells may be

exploited to selectively affect renal nerve cells with reduced effect on smooth muscle cells. More specifically, because larger cells require less energy to exceed the irreversibility threshold of electroporation, several embodiments of electrodes of the present disclosure are configured to align at least a portion of an electric field generated by the electrodes with or near the longer dimensions of the cells to be affected. In specific embodiments, the extravascular device has electrodes configured to create an electrical field aligned with or near the lengthwise dimension L of the renal artery **RA** to affect renal nerves **RN**. By aligning an electric field so that the field preferentially affects the lengthwise aspect of the cell rather than the diametric or radial aspect of the cell, lower field strengths may be used to necrose cells. As mentioned above, this is expected to reduce power consumption and mitigate effects on non-target cells in the electric field.

[0063] Similarly, the lengthwise or longer dimensions of tissues overlying or underlying the target nerve are orthogonal or otherwise off-axis (e.g., transverse) with respect to the longer dimensions of the nerve cells. Thus, in addition to aligning the PEF with the lengthwise or longer dimensions of the target cells, the PEF may propagate along the lateral or shorter dimensions of the non-target cells (i.e., such that the PEF propagates at least partially out of alignment with non-target smooth muscle cells **SMC**). Therefore, as seen in Figure 3, applying a PEF with propagation lines L_i generally aligned with the longitudinal dimension L of the renal artery **RA** is expected to preferentially cause electroporation, electrofusion, denervation or other neuromodulation in cells of the target renal nerves **RN** without unduly affecting the non-target arterial smooth muscle cells **SMC**. The pulsed electric field may propagate in a single plane along the longitudinal axis of the renal artery, or may propagate in the longitudinal direction along any angular segment θ through a range of 0° - 360° .

[0064] Embodiments of the method shown in Figure 3 may have particular application with the extravascular methods and apparatus of the present disclosure. For instance, a PEF system placed exterior to the renal artery may propagate an electric field having a longitudinal portion that is aligned to run with the longitudinal dimension of the artery in the region of the renal nerves **RN** and the smooth muscle cell **SMC** of the vessel wall so that the wall of the artery remains at least substantially intact while the outer nerve cells are destroyed.

C. Embodiments of Systems and Additional Methods for Neuromodulation

[0065] Figure 4 shows one embodiment of an extravascular pulsed electric field apparatus 200 in accordance with the present disclosure that includes one or more electrodes configured to deliver a pulsed electric field to renal neural fibers to achieve renal neuromodulation. Apparatus 200 comprises a laparoscopic or percutaneous

PEF system having probe 210 configured for insertion in proximity to the track of the renal neural supply along the renal artery or vein or hilum and/or within Gerota's fascia under, e.g., CT or radiographic guidance. The proximal section of probe 210 generally has an electrical connector to couple the probe to pulse generator 100, and the distal section has at least one electrode 212.

[0066] Pulsed electric field generator 100 is located external to the patient, and the electrode(s) 212 are electrically coupled to the generator via probe 210 and wires 211. The generator 100, as well as any of the electrode embodiments described herein, may be utilized with any embodiment of the present disclosure described hereinafter for delivery of a PEF with desired field parameters. It should be understood that electrodes of embodiments described hereinafter may be electronically connected to the generator, even if the generator is not explicitly shown or described with each embodiment.

[0067] The electrode(s) 212 can be individual electrodes, a common but segmented electrode, or a common and continuous electrode. A common but segmented electrode may, for example, be formed by providing a slotted tube fitted onto the electrode, or by electrically connecting a series of individual electrodes. Individual electrodes or groups of electrodes 212 may be configured to provide a bipolar signal. Electrodes 212 may be dynamically assignable to facilitate monopolar and/or bipolar energy delivery between any of the electrodes and/or between any of the electrodes and external ground pad 214. Ground pad 214 may, for example, be attached externally to the patient's skin, e.g., to the patient's leg or flank.

[0068] As seen in Figure 4, electrode 212 may comprise a single electrode that is used in conjunction with separate patient ground pad 214 located external to the patient and coupled to generator 100 for monopolar use. Probe 210 optionally may comprise a conductive material that is insulated in regions other than its distal tip, thereby forming distal tip electrode 212. Alternatively, electrode 212 may, for example, be delivered through a lumen of probe 210. Probe 210 and electrode 212 may be of the standard needle or trocar-type used clinically for pulsed RF nerve block, such as those sold by Valleylab (a division of Tyco Healthcare Group LP) of Boulder, Colorado. Alternatively, apparatus 200 may comprise a flexible and/or custom-designed probe for the renal application described herein.

[0069] In Figure 4, percutaneous probe 210 has been advanced through percutaneous access site **P** into proximity within renal artery **RA**. Once properly positioned, pulsed electric field therapy may be applied to target neural fibers across electrode 212 and ground pad 214. After treatment, apparatus 200 may be removed from the patient to conclude the procedure.

[0070] It is expected that such therapy will alleviate clinical symptoms of CHF, hypertension, renal disease and/or other cardio-renal diseases for a period of months, potentially up to six months or more. This time period

might be sufficient to allow the body to heal, for example, this period might reduce the risk of CHF onset after an acute myocardial infarction, thereby alleviating a need for subsequent re-treatment. Alternatively, as symptoms reoccur, or at regularly scheduled intervals, the patient might return to the physician for a repeat therapy.

[0071] The need for a repeat therapy optionally might be predicted by monitoring of physiologic parameters, for example, by monitoring specific neurohormones (plasma renin levels, etc.) that are indicative of increased sympathetic nervous activity. Alternatively, provocative maneuvers known to increase sympathetic nervous activity, such as head-out water immersion testing, may be conducted to determine the need for repeat therapy.

[0072] In some embodiments, apparatus 200 may comprise a probe having an introducer with an expandable distal segment having one or more electrodes. After insertion in proximity to target neural fibers, the distal segment may be opened or expanded into an expanded configuration. In one embodiment, this expanded configuration would follow a contour of the renal artery and/or vein to treat a number of neural fibers with a single application of PEF therapy. For example, in the expanded configuration, the distal segment may partially or completely encircle the renal artery and/or vein. In another embodiment, the expanded configuration may facilitate mechanical dissection, for example, to expand Gerota's fascia and create a working space for placement of the electrodes and/or for delivery of PEF therapy. The distal segment optionally may be translated independently of the probe or introducer.

[0073] When utilized as an electrode, the distal segment may, for example, be extended out of an introducer placed near the treatment area. The conducting distal segment maybe advanced out of the sheath until a desired amount of renal neural tissue is contacted, and then PEF therapy may be delivered via the distal segment electrode. Alternatively, the conducting distal segment may be allowed to reform or expand into a spiral of one or more loops, a random space-occupying shape, or another suitable configuration. Mesh, braid, or conductive gels or liquids could be employed in a similar manner.

[0074] Figure 5 illustrates another embodiment of apparatus 200 comprising an expandable distal segment. In Figure 5, apparatus 200 comprises introducer probe 220 and electrode element 230 with a distal segment 232 that may be expandable. Probe 220 may, for example, comprise a standard needle or trocar. Electrode element 230 is proximally coupled to generator 100 and is configured for advancement through probe 220. Distal segment 232 of the electrode element may be delivered to a treatment site in a closed or contracted configuration within probe 220 and then opened or expanded to a treatment configuration at or near the treatment site. For example, the distal segment 232 can be expanded by advancing segment 232 out of probe 220 and/or by retracting the probe relative to the distal segment. The embodiment of the distal segment 232 shown in Figure 5 com-

prises a basket or cup-shaped element in a deployed configuration 234 for delivering treatment. The distal segment 232 preferably self-expands to the treatment configuration. The apparatus 200 can further include one or more electrodes 233 coupled to distal segment 232.

[0075] As seen in Figure 5, distal segment 232 partially or completely encircles or surrounds renal artery RA in the deployed configuration 234. PEF therapy delivered through electrode element 230 to electrodes 233 in a bipolar or monopolar fashion may achieve a more thorough or complete renal neuromodulation than a PEF therapy delivered from electrodes along only one side of the artery or at an electrode at a single point along the artery. Electrode element 230 optionally may be electrically isolated from probe 220 such that the probe and electrodes 233 form two parts of a bipolar system in which the probe 220 is a return electrode.

[0076] With reference to Figure 6, distal segment 232 alternatively may comprise a spiral element 236 in the treatment configuration. The distal segment may, for example, be pre-formed into a spiral configuration. The spiral might be straightened through a number of different mechanisms (e.g., positioning within probe 220, pull wires to actuate segment 232 between straight and spiraled, a shape-memory material, etc.) for insertion into proximity, e.g., with the renal vasculature. Once near a target vessel, the spiral may be actuated or allowed to reform in order to more fully encircle the vessel, thereby facilitating treatment of a greater number of neural fibers with a single application of PEF therapy.

[0077] The spiral or helical element 236 of distal segment 232 is configured to appose the vessel wall and bring electrode(s) 233 into close proximity to renal neural structures. The pitch of the helix can be varied to provide a longer treatment zone or to minimize circumferential overlap of adjacent treatments zones, e.g., in order to reduce a risk of stenosis formation. This pitch change can be achieved, for example, via (a) a heat-set, (b) combining a plurality of segments of different pitches to form segment 232, (c) adjusting the pitch of segment 232 through the use of internal pull wires, (d) adjusting mandrels inserted into the segment, (e) shaping sheaths placed over the segment, or (f) any other suitable means for changing the pitch either in-situ or before introduction into the body.

[0078] As with previous embodiments, the electrode(s) 233 along the length of distal segment 232 can be individual electrodes, a common but segmented electrode, or a common and continuous electrode. A common and continuous electrode may, for example, comprise a conductive coil formed into or placed over the helix of distal segment 232. Individual electrodes or groups of electrodes 233 may be configured to provide a bipolar signal, or any configuration of the electrodes may be used together at a common potential in conjunction with a separate external patient ground for monopolar use. Electrodes 233 may be dynamically assignable to facilitate monopolar and/or bipolar energy delivery between any

of the electrodes and/or between any of the electrodes and an external ground. Distal segment 232 optionally may be insulated on a side facing away from the renal artery such that at least portions of the side of the segment configured to face the renal artery are exposed to form electrode(s) 233.

[0079] Distal segment 232 of electrode element 230 may be delivered in proximity to renal artery **RA** in a low profile delivery configuration within probe 220. Once positioned in proximity to the artery, distal segment 232 may self-expand or may be expanded actively, e.g., via a pull wire or a balloon, into the spiral configuration 236 about the wall of the artery. The distal segment may, for example, be guided around the vessel, e.g., via steering and blunt dissection, and activated to take on the tighter-pitch coil of the spiral configuration 236. Alternatively or additionally, the distal segment might be advanced relative to probe 220 and snaked around the artery via its predisposition to assume the spiral configuration. Positioning the distal segment within Gerota's fascia might facilitate placement of distal segment 232 around the artery.

[0080] Once properly positioned, a pulsed electric field then may be generated by the PEF generator 100, transferred through electrode element 230 to electrodes 233, and delivered via the electrodes to renal nerves located along the artery. In many applications, the electrodes are arranged so that the pulsed electric field is aligned with the longitudinal dimension of the artery to modulate the neural activity along the renal nerves (e.g., denervation). This may be achieved, for example, via irreversible electroporation, electrofusion and/or inducement of apoptosis in the nerve cells.

[0081] Referring to Figure 7, another percutaneous or laparoscopic method and apparatus for renal neuromodulation is described. In Figure 7, distal segment 232 of electrode element 230 of apparatus 200 comprises electrode 233 having ring or cuff configuration 238. The ring electrode may partially surround renal artery **RA**, as shown. Electrode 233 optionally may comprise retractable pin 239 for closing the ring to more fully or completely encircle the artery once the electrode has been placed about the artery. A PEF therapy may be delivered via the electrode to achieve renal neuromodulation. As an alternative to laparoscopic placement, ring electrode 238 optionally may be surgically placed.

[0082] Figure 8 illustrates another percutaneous or laparoscopic method and apparatus for renal neuromodulation comprising a spreading electrode configured for positioning near the renal hilum. As seen in Figure 8, distal segment 232 of electrode element 230 may comprise fan-shaped member 240 having a plurality of fingers that may be collapsed or constrained within probe 220 during percutaneous introduction to, and/or retraction from, a treatment site. One or more electrodes 233 may be positioned along the fingers of the distal segment. Once in the area of the renal vasculature and/or renal hilum **H**, the fan may be extended, or probe 220 may be retracted, to deploy distal segment 232. The fingers, for

example, spread out to cover a larger treatment area along the vasculature or renal hilum that facilitates treatment of a greater number of target neural fibers and/or creates a working space for subsequent introduction of electrodes 233.

[0083] In Figure 8, a distal region of probe 220 is positioned in proximity to renal hilum **H**, and the fan-shaped distal segment 232 has been expanded to the deployed configuration. PEF therapy then may be delivered via electrodes 233 to neural fibers in that region for renal neuromodulation.

[0084] With reference to Figure 9, distal segment 232 alternatively may comprise a tufted element 242 having one or more strands with electrodes 233. Distal segment 232 may be positioned in proximity to renal hilum **H** within probe 220, and then the tufted element 242 can be expanded to a space-occupying configuration. Electrodes 233 then may deliver PEF therapy to renal nerves.

[0085] With reference to Figure 10, probe 220 optionally may pierce fascia **F** (e.g. Gerota's fascia) that surrounds kidney **K** and/or renal artery **RA**. Distal segment 232 may be advanced through probe 220 between the fascia and renal structures, such as hilum **H** and artery **RA**. This may position electrodes 233 into closer proximity with target renal neural structures. For example, when distal segment 232 comprises the fan-shaped member 240 of Figure 8 or the tufted element 242 of Figure 9, expansion of the distal segment within fascia **F** may place electrodes 233 into proximity with more target renal neural structures and/or may create a working space for delivery of one or more electrodes 233 or of conducting gels or liquids, etc.

[0086] Referring to Figures 11A and 11B, methods and apparatus for mechanically anchoring probe 220, distal segment 232 of electrode element 230, and/or electrode(s) 233 within fascia **F** are described. Figures 11A and 11B illustrate mechanical anchoring element 250 in combination with distal segment 232 of electrode element 230, but this should in no way be construed as limiting because the apparatus 200 does not need to include the anchoring element 250. In embodiments with the anchoring element, distal segment 232 may be expandable or non-expandable.

[0087] In the embodiment of Figure 11A, distal segment 232 comprises anchoring element 250 having collar 252 disposed about the distal segment. Self-expanding wire loops 254 of the anchoring element extend from the collar. The loops 254 may be collapsed against the shaft of distal segment 232 while the distal segment is disposed within probe 220 (as illustrated in dotted profile in Figure 11A). Probe 220 may pierce the fascia near a treatment site, thereby positioning a distal tip of the probe within the fascia. The probe then may be retracted relative to electrode element 230 (and/or the electrode element may be advanced relative to the probe) to position distal segment 232 distal of the probe. The loops 254 self-expand in a manner that mechanically anchors distal segment 232 within the fascia. Alternatively, anchoring

element 250 may be actively expanded, e.g., in a mechanical fashion.

[0088] The loops 254 optionally may be covered with an elastic polymer, such as silicone, CFlex, urethane, etc., such that the anchoring element 250 at least partially seals an entry site into fascia **F**. This may facilitate immediate infusion of fluids through probe 220 or electrode element 230 without leakage or with reduced leakage. Additionally or alternatively, when electrode element 230 is configured for longer-term implantation, anchoring element 250 may be covered in a porous material, such as a polyester fabric or mesh, that allows or promotes tissue in-growth. Tissue in-growth may enhance the anchoring providing by element 250 for maintaining the position of distal segment 232 and/or electrode(s) 233. Tissue in-growth may also enhance sealing at the entry site into the **fascia**.

[0089] In the embodiment of Figure 11B, distal segment 232 is cut in the longitudinal direction to create a series of flaps 256 around the catheter that form an alternative anchoring element 250. Pull-wire 258 may, for example, extend along the exterior of electrode element 230 or may be disposed within a lumen of the electrode element, and is coupled to distal segment 232 distal of flaps 256. Once distal segment 232 is positioned within fascia **F**, pull-wire 258 is moved proximally to extend the flaps 256 and anchor the distal segment within the fascia. Alternatively, other expandable members incorporating wires, baskets, meshes, braids or the like may be mechanically expanded to provide anchoring.

[0090] With anchoring element 250 expanded, an infusate optionally may be infused through slits 256. Furthermore, as with the embodiment of Figure 11A, anchoring element 250 of Figure 11B optionally may be covered with an elastic polymer covering to create a gasket for sealing the entry site into the fascia. In such a configuration, infusion holes may be provided distal of the anchoring element. Alternatively, a proximal portion of the slit section of anchoring element 250 may be covered with the elastic polymer, while a distal portion remains uncovered, for example, to facilitate infusion through slits 256. In another embodiment, anchoring element 250 of Figure 11B may comprise a porous material to facilitate tissue in-growth, as described previously. As with the elastic polymer, the porous material optionally may cover only a portion of the anchoring element to facilitate, for example, both tissue in-growth and infusion.

[0091] Figure 12 shows a method and apparatus for renal neuromodulation in which electrodes are positioned along a patient's renal vasculature within an annular space between the vasculature and the surrounding fascia. The electrodes may be positioned in proximity to the renal artery and/or the renal vein by guiding a needle within fascia **F** using, for example, Computed Tomography ("CT") guidance. The needle may comprise introducer probe 220, or the probe may be advanced over and exchanged for the needle after placement of the needle within the fascia.

[0092] When the probe 220 is within the Gerota's fascia, the electrode element 230 is delivered through the probe in close proximity to renal vasculature (e.g., the renal artery **RA**). The electrode element optionally may be advanced along the length of the artery toward the patient's aorta to bluntly dissect a space for the electrode element as the electrode element is advanced. The electrode element 230 may comprise a catheter, and electrodes 233 coupled to the electrode element 230 may deliver PEF therapy or other types of therapy to renal neural structures located along the renal artery. Bipolar or monopolar electrode(s) may be provided as desired.

[0093] With reference to Figures 13A-C, various additional embodiments of electrodes 233 and distal segment 232 of electrode element 230 are described. In Figure 13A, electrodes 233 comprise a pair of bipolar electrode coils disposed about distal segment 232. In Figure 13B, electrodes 233 comprise a pair of bipolar electrodes having contoured metal plates disposed on the side of distal segment 232 facing renal artery **RA** to face target renal neural structures. This is expected to preferentially direct PEF therapy delivered between electrodes 233 towards the renal artery. As seen in Figure 13C, distal segment 232 and/or electrodes 233 may comprise a concave profile so that more surface area of the electrodes is juxtaposed with the wall of the renal artery. When the pulsed electric field delivered by electrodes 233 is strong enough, suitably directed and/or in close enough proximity to target neural structures, it is expected that the electrodes may achieve a desired level of renal neuromodulation without fully encircling the renal artery.

[0094] Figures 14A-C show another method and apparatus for positioning electrodes along the patient's renal artery. In addition to probe 220 and electrode element 230, apparatus 200 of Figures 14A-C comprises catheter 300. Electrode element 230 is positioned within catheter 300 and optionally may comprise an atraumatic tip of the catheter. As seen in Figure 14A, catheter 300 may be advanced through probe 220 within the annular space between the fascia **F** and the renal vasculature shown as renal artery **RA**. The catheter and/or the probe optionally may be advanced over a guidewire. Various agents may be infused through the catheter to create a working space for advancement of the catheter and/or to facilitate placement of electrodes 233.

[0095] Once positioned as desired at a treatment site, the catheter may be retracted relative to the electrode element to expose electrodes 233 along distal segment 232 of the electrode element, as in Figure 14B. The electrodes 233 in Figures 14A-C may comprise a bipolar pair of expandable electrodes that may be collapsed for delivery within catheter 300. The electrodes may, for example, be fabricated from a self-expanding material, such as spring steel or Nitinol. Although electrodes 233 illustratively are on a common electrode element 230, it should be understood that multiple electrode elements 230 each having one or more electrodes 233 may be delivered through catheter 300 and positioned as desired

along the renal vasculature.

[0096] In the expanded configuration of Figure 14B, electrodes 233 at least partially surround or encircle renal artery **RA**. It is expected that at least partially encircling the renal artery during PEF therapy will enhance the efficacy of renal neuromodulation or denervation. The electrodes may be used to deliver PEF therapy and/or to stimulate a physiologic response to test or to challenge an extent of neuromodulation, as well as to apply energy to disrupt, modulate or block renal nerve function. Various agents may be infused in the vicinity of electrodes 233 prior to, during or after energy delivery, for example, to aid in conduction (e.g., saline and hypertonic saline), to improve electroporative effect (e.g., heated solutions) or to provide protection to non-target cells (e.g., cooling solutions or Poloxamer-188).

[0097] Electrodes 233 may, for example, comprise coils, wires, ribbons, polymers, braids or composites. Polymers may be used in combination with conductive materials to direct a pulsed electric field into and/or along target tissue while insulating surrounding tissue. With reference to Figure 14C, distal segment 232 of electrode element 230 may comprise insulation I that is locally removed or omitted along an inner surface of electrodes 233 where the electrodes face or contact renal vasculature.

[0098] Referring now to Figures 15A-B, another embodiment of the apparatus and method of Figures 14A-C is described. As seen in Figure 15A, electrode(s) 233 may comprise an undulating or sinusoidal configuration that extends along the renal vasculature. The sinusoidal configuration of electrodes 233 may provide for greater contact area along the vessel wall than do electrodes 233 of Figures 14A-C, while still facilitating sheathing of electrode element 230 within catheter 300 for delivery and/or retrieval. Electrode(s) 233 may comprise a unitary electrode configured for monopolar energy delivery, or distal segment 232 of electrode element 230 may comprise insulation that is locally removed or omitted to expose electrodes 233. Alternatively, as seen in Figure 15B, the electrodes may comprise discrete wire coils or other conductive sections attached to the undulating distal segment 232. Electrodes 233 may be energized in any combination to form a bipolar electrode pair.

[0099] Figure 16 is a schematic view illustrating yet another embodiment of the method and apparatus of Figures 14A-C. In Figure 16, catheter 300 comprises multiple lumens 304 through which electrode elements 230 may be advanced and electrodes 233 may be collapsed for delivery. When positioned at a treatment site, electrode elements 230 may be advanced relative to catheter 300 and/or the catheter 300 may be retracted relative to the electrode elements, such that electrodes 233 expand to the configuration of Figure 16 for at least partially encircling renal vasculature. In Figure 16, apparatus 200 illustratively comprises two electrode elements 230, each having an expandable electrode 233. The two electrodes 233 may be used as a bipolar electrode pair during PEF

therapy. Electrode elements 230 may be translated independently, such that a separation distance between electrodes 233 may be altered dynamically, as desired.

[0100] Figures 17A-B show still another embodiment of the method and apparatus of Figures 14A-C. In Figure 17A, electrode 233 comprises a panel that may be rolled into scroll for low-profile delivery within catheter 300. As seen in Figure 17B, the catheter may be retracted relative to the electrode, and/or the electrode may be advanced relative to the catheter, such that panel unfurls or unrolls, preferably in a self-expanding fashion, to partially or completely encircle renal artery **RA**. PEF therapy may be delivered through electrode 233 in a monopolar fashion, or the electrode may be segmented to facilitate bipolar use. Alternatively, a second electrode may be delivered in proximity to electrode 233 for bipolar PEF therapy.

[0101] Any of the electrode embodiments 212 or 233 of Figures 5-17B may be configured for use in a single PEF therapy session, or may be configured for implantation for application of follow-on PEF therapy sessions. In implantable embodiments, leads may, for example, extend from electrodes 212 or 233 to a subcutaneous element controllable through the skin or to an implantable controller.

[0102] With reference to Figure 18, when electrodes 233 are configured for implantation, distal segment 232 of electrode element 230 may, for example, be detachable at a treatment site, such that electrodes 233 are implanted in the annular space between renal artery **RA** and fascia F, while a proximal portion of electrode element 230 is removed from the patient. As seen in Figure 18, electrode element 230 may comprise leads 260 for tunneling to a subcutaneous element or to an implantable controller. The electrode element further comprises detachment mechanism 270 disposed just proximal of distal segment 232 for detachment of the distal segment at the treatment site. Distal segment 232 optionally may comprise elements configured to promote tissue in-growth in the vicinity of electrodes 233.

[0103] With reference to Figures 19A-20, partially and completely implantable PEF systems are described. Figures 19A-B illustrate partially implantable systems having a pulsed electric field generator 100 connected either directly or indirectly to a subcutaneous element 400 through or across the patient's skin. Subcutaneous element 400 may be placed, for example, posteriorly, e.g., in the patient's lower back. In Figures 19A-B, the subcutaneous element 400 is attached to leads 260, and the leads 260 are electrically coupled to implanted electrodes 233 positioned in proximity to the renal artery, renal vein, renal hilum, Gerota's fascia or other suitable structures. Electrodes 233 can be located bilaterally, i.e., in proximity to both the right and left renal vasculature, but alternatively may be positioned unilaterally. Furthermore, multiple electrodes may be positioned in proximity to either or both kidneys for bipolar PEF therapy, or monopolar electrodes may be provided and used in combination with a return electrode, such as external ground pad 214 or

a return electrode integrated with subcutaneous element 400.

[0104] As seen in Figure 19A, subcutaneous element 400 may comprise a subcutaneous port 402 having an electrical contact 403 comprising one or more connecting or docking points for coupling the electrical contact(s) to generator 100. In a direct method of transmitting a PEF across the patient's skin, a transcutaneous needle, trocar, probe or other element 410 that is electrically coupled to generator 100 pierces the patient's skin and releasably couples to contact 403. Transcutaneous element 410 conducts PEF therapy from the generator 100 across or through the patient's skin to subcutaneous contact 403 and to electrodes 233 for modulating neural fibers that contribute to renal function. The implanted system might also incorporate an infusion lumen to allow drugs to be introduced from subcutaneous port 402 to the treatment area.

[0105] In addition to direct methods of transmitting PEF signals across the patient's skin, such as via transcutaneous element 410, indirect methods alternatively may be utilized, such as transcutaneous energy transfer ("TET") systems. TET systems are used clinically to recharge batteries in rechargeable implantable stimulation or paving devices, left ventricular assist devices, etc. In the TET embodiment of Figure 19B, subcutaneous element 400 comprises subcutaneous receiving element 404, and external TET transmitting element 420 is coupled to generator 100. A PEF signal may be transmitted telemetrically through the skin from external transmitting element 420 to subcutaneous receiving element 404. Passive leads 260 connect the subcutaneous receiving element to nerve electrodes 233 and may conduct the signal to the nerves for treatment.

[0106] With reference to Figure 20, a fully implantable PEF system is described. In Figure 20, subcutaneous receiving element 404 is coupled to a capacitor or other energy storage element 430, such as a battery, which in turn is coupled to implanted controller 440 that connects via leads 260 to electrodes 233. External transmitting element 420 is coupled to external charger and programmer 450 for transmitting energy to the implanted system and/or to program the implanted system. Charger and programmer 450 need not supply energy in the form of a PEF for transmission across the patient's skin from external element 420 to receiving element 404. Rather, controller 440 may create a PEF waveform from energy stored within storage element 430. The controller optionally may serve as a return electrode for monopolar-type PEF therapy.

[0107] The embodiment of Figure 20 illustratively is rechargeable and/or reprogrammable. However, it should be understood that the fully implanted PEF system alternatively may be neither rechargeable nor programmable. Rather, the system may be powered via storage element 430, which, if necessary, may be configured for surgical replacement after a period of months or years after which energy stored in the **storage element** has been **deplet-**

ed.

[0108] When using a percutaneous or implantable PEF system, the need for repeat therapy, the location for initial therapy and/or the efficacy of therapy, optionally may be determined by the system. For example, an implantable system periodically may apply a lower-frequency stimulation signal to renal nerves; when the nerve has returned toward baseline function, the test signal would be felt by the patient, and the system would apply another course of PEF therapy. This repeat treatment optionally might be patient initiated: when the patient feels the test signal, the patient would operate the implantable system via electronic telemetry, magnetic switching or other means to apply the required therapeutic PEF.

[0109] As an alternative or in addition to eliciting a pain response, the responses of physiologic parameters known to be affected by stimulation of the renal nerves may be monitored. Such parameters comprise, for example, renin levels, sodium levels, renal blood flow and blood pressure. When using stimulation to challenge denervation and monitor treatment efficacy, the known physiologic responses to stimulation should no longer occur in response to such stimulation.

[0110] Efferent nerve stimulation waveforms may, for example, comprise frequencies of about 1-10 Hz, while afferent nerve stimulation waveforms may, for example, comprise frequencies of up to about 50 Hz. Waveform amplitudes may, for example, range up to about 50V, while pulse durations may, for example, range up to about 20 milliseconds. Although exemplary parameters for stimulation waveforms have been described, it should be understood that any alternative parameters may be utilized as desired.

[0111] The electrodes used to deliver PEFs in any of the previously described variations of the present disclosure also may be used to deliver stimulation waveforms to the renal vasculature. Alternatively, the variations may comprise independent electrodes configured for stimulation. As another alternative, a separate stimulation apparatus may be provided.

[0112] As mentioned, one way to use stimulation to identify renal nerves is to stimulate the nerves such that renal blood flow is affected - or would be affected if the renal nerves had not been denervated or modulated. As stimulation acts to reduce renal blood flow, this response may be attenuated or abolished with denervation. Thus, stimulation prior to neural modulation would be expected to reduce blood flow, while stimulation after neural modulation would not be expected to reduce blood flow to the same degree when utilizing similar stimulation parameters and location(s) as prior to neural modulation. This phenomenon may be utilized to quantify an extent of renal neuromodulation.

[0113] Embodiments of the present disclosure may comprise elements for monitoring renal blood flow or for monitoring any of the other physiological parameters known to be affected by renal stimulation. Renal blood flow optionally may be visualized through the skin (e.g.,

using an ultrasound transducer). An extent of electroporation additionally or alternatively may be monitored directly using Electrical Impedance Tomography ("EIT") or other electrical impedance measurements or sensors, such as an electrical impedance index.

[0114] In addition or as an alternative to stimulation, other monitoring methods which check for measures of the patient's clinical status may be used to determine the need for repeat therapy. These monitoring methods could be completely or partially implantable, or they could be external measurements which communicate telemetrically with implantable elements. For instance, an implantable pressure sensor of the kind known in the field (e.g., sensors developed by CardioMEMS of Atlanta, GA) could measure right atrial pressure. Increasing right atrial pressure is a sign of fluid overload and improper CHF management. If an increase in right atrial pressure is detected by the sensor, a signal might be sent to controller 440 and another PEF treatment would be delivered. Similarly, arterial pressure might be monitored and/or used as a control signal in other disease conditions, such as the treatment of high blood pressure. Alternatively, invasive or non-invasive measures of cardiac output might be utilized. Non-invasive measures include, for example, thoracic electrical bioimpedance.

[0115] In yet another embodiment, weight fluctuation is correlated with percentage body fat to determine a need for repeat therapy. It is known that increasing patient weight, especially in the absence of an increase in percent body fat, is a sign of increasing volume overload. Thus, the patient's weight and percentage body fat may be monitored, e.g., via a specially-designed scale that compares the weight gain to percentage body fat. If it is determined that weight gain is due fluid overload, the scale or other monitoring element(s) could signal controller 440, e.g., telemetrically, to apply another PEF treatment.

[0116] When using partially or completely implantable PEF systems, a thermocouple, other temperature or impedance monitoring elements, or other sensors, might be incorporated into subcutaneous elements 400. External elements of the PEF system might be designed to connect with and/or receive information from the sensor elements. For example, in one embodiment, transcutaneous element 410 connects to subcutaneous electrical contact 403 of port 402 and can deliver stimulation signals to interrogate target neural tissue to determine a need, or parameters, for therapy, as well as to determine impedance of the nerve and nerve electrodes. Additionally, a separate connector to mate with a sensor lead may be extended through or alongside transcutaneous element 410 to contact a corresponding subcutaneous sensor lead.

[0117] Alternatively, subcutaneous electrical contact 403 may have multiple target zones placed next to one another, but electrically isolated from one another. A lead extending from an external controller, e.g., external generator 100, would split into several individual transcuta-

neous needles, or individual needle points coupled within a larger probe, which are inserted through the skin to independently contact their respective subcutaneous target zones. For example, energy delivery, impedance measurement, interrogative stimulation and temperature each might have its own respective target zone arranged on the subcutaneous system. Diagnostic electronics within the external controller optionally may be designed to ensure that the correct needle is in contact with each corresponding subcutaneous target zone.

[0118] Elements may be incorporated into the implanted elements of PEF systems to facilitate anchoring and/or tissue in-growth. For instance, fabric or implantable materials, such as Dacron or ePTFE, might be incorporated into the design of the subcutaneous elements 400 to facilitate in-growth into areas of the elements that would facilitate anchoring of the elements in place, while optionally repelling tissue in-growth in undesired areas, such as along electrodes 233. Similarly, coatings, material treatments, drug coatings or drug elution might be used alone or in combination to facilitate or retard tissue in-growth into various elements of the implanted PEF system, as desired.

[0119] Any of the embodiments of the present disclosure described herein optionally may be configured for infusion of agents into the treatment area before, during or after energy application, for example, to create a working space to facilitate electrode placement, to enhance or modify the neurodestructive or neuromodulatory effect of applied energy, to protect or temporarily displace non-target cells, and/or to facilitate visualization. Additional applications for infused agents will be apparent. If desired, uptake of infused agents by cells may be enhanced via initiation of reversible electroporation in the cells in the presence of the infused agents. The infusate may comprise, for example, fluids (e.g., heated or chilled fluids), air, CO₂, saline, heparinized saline, hypertonic saline, contrast agents, gels, conductive materials, space-occupying materials (gas, solid or liquid), protective agents, such as Poloxamer-188, anti-proliferative agents, or other drugs and/or drug delivery elements. Variations of the present disclosure additionally or alternatively may be configured for aspiration.

[0120] Figures 21A and 21B illustrate another embodiment of the apparatus 200 in accordance with the disclosure. Referring to Figure 21A, the apparatus 200 includes the probe 220 and a catheter 300 received within the probe 220. The catheter 300 includes an anchoring mechanism 251 having a first collar 280, a second collar 282 located distally relative to the first collar 280, and an expandable member 284 connected to the first and second collars 280 and 282. The expandable member 284 can be a braid, mesh, woven member or other device that expands as the distance between the first and second collars 280 and 282 is reduced. The expandable member 284 can include polyesters, Nitinol, elgiloy, stainless steel, composites and/or other suitable materials. The collars 280 and 282, and/or the expandable

member 284, may be at least partially covered in an expandable polymer to form a seal with the patient. The apparatus 200 can further include a plurality of electrodes 230 located at the expandable member 284 and/or the first or second collars 280 or 282.

[0121] The anchoring mechanism 250 operates by moving at least one of the collars 280 and 282 toward the other to reduce the distance between the collars. For example, the first collar 280 can be slidable along the catheter 300, and the second collar 282 can be fixed to the catheter 300. Referring to Figure 21B, the expandable member 284 can be expanded by pulling back on the catheter 300 to engage the proximal collar 280 with the distal end of the probe 220. As the catheter 300 is withdrawn proximally relative to the probe 220, the distal end of the probe 220 drives the first collar 280 toward the second collar 282 to move the anchoring mechanism 251 from a collapsed position shown in Figure 21A to an expanded configuration illustrated in Figure 21B. Alternatively, the apparatus 200 can include an actuator that can be advanced distally to drive the first collar 280 toward the second collar 282. The actuator, for example, can be a coaxial sleeve around the catheter 300 that may be operated from the proximal end of the probe 220.

[0122] Figures 22A and 22B illustrate another embodiment of the apparatus 200 in accordance with the disclosure. In this embodiment, the apparatus 200 includes a probe 220 and a catheter 300 that moves through the probe 220 as described above with reference to Figures 11A-B. The apparatus 200 of this embodiment further includes an anchoring mechanism 253 having a first collar 281, a second collar 283 located distally along the catheter 300 relative to the first collar 281, and an expandable member 285 attached to the first and second collars 281 and 283. In one embodiment, the first collar 281 is slidably movable along the catheter 300, and the second collar 283 is fixed to the catheter 300. Alternatively, the first collar 281 can be fixed to the catheter 300 and the second collar 283 can be movable along the catheter 300. The expandable member 285 is a self-contracting member that is actively stretched into a collapsed configuration to be contained within the probe 220 for delivery to the desired treatment site in the patient. Figure 22A illustrates the expandable member 285 stretched into an elongated state to be constrained within the probe 220. Referring to Figure 22B, the apparatus 200 is deployed in the patient by moving the probe 220 proximally relative to the catheter 300 and/or moving the catheter 300 distally relative to the probe 220 until the expandable member 285 is outside of the probe 220. Once the expandable member 285 is outside of the probe 220, the expandable member 285 draws the movable collar toward the fixed collar to allow the expandable member 285 to expand outwardly relative to the radius of the catheter shaft 300.

[0123] The expandable member 285 can be a spring formed from a polyester, stainless steel, composites or other suitable materials with sufficient elasticity to inher-

ently move into the expanded configuration shown in Figure 22B. Alternatively, the expandable member can be formed from a shaped memory metal, such as Nitinol or elgiloy, that moves from the collapsed configuration illustrated in Figure 22A to the expanded configuration illustrated in Figure 22B at a given temperature. In either embodiment the apparatus 200 can further include electrodes (not shown) located along the expandable member for delivering the pulsed electric field to the renal nerve or other structure related to renal/cardio activity.

[0124] Figure 23 illustrates yet another embodiment of a method and apparatus for positioning an electrode relative to a renal structure to deliver a PEF for neuromodulation. In this embodiment, the apparatus includes a first percutaneous member 510, a second percutaneous member 520, an electrode assembly 530, and a retriever 540. The first percutaneous member 510 can be a first trocar through which the electrode assembly 530 is delivered to the renal artery **RA** or other renal structure, and the second percutaneous member 520 can be a second trocar through which the retriever 540 is delivered to the general region of the electrode assembly 530. In the embodiment shown in Figure 23, the electrode assembly 530 includes an electrode 532, and the retriever 540 is a snare configured to capture the electrode assembly. In operation, the first percutaneous member 510 is inserted into the patient and the electrode assembly 530 is passed through the first percutaneous member 510 until the electrode 532 is at or near a desired location relative to the renal structure. The second percutaneous member 520 is also inserted into the patient so that the retriever 540 can engage the electrode assembly 530. The retriever 540 can be used to hold the electrode 532 at the desired location during delivery of a PEF to the patient and/or to remove the electrode assembly 530 after delivering the PEF.

[0125] Although preferred illustrative variations of the present invention are described above, it will be apparent to those skilled in the art that various changes and modifications may be made thereto without departing from the invention. For example, although the variations primarily have been described for use in combination with pulsed electric fields, it should be understood that any other electric field may be delivered as desired.

Claims

1. Apparatus configured for renal neuromodulation, e.g. renal denervation, the apparatus comprising:

an introducer probe (220) configured for percutaneous insertion and extravascular placement proximate a renal nerve and within Gerota's fascia under guidance, and
an electrode element (230) with an expandable distal segment having one or more electrodes, wherein the electrode element is configured for

- advancement through the probe, wherein the distal segment is configured to be arranged in (a) a reduced delivery configuration for placement adjacent to a renal vasculature and (b) an expanded treatment configuration for delivering the electric field to the renal nerve, and wherein the distal segment is configured to be expanded into a space-occupying shape, and wherein the one or more electrodes are configured to be electrically coupled to an electric field generator, and to deliver an electric field to the renal nerve while being located proximate the renal nerve.
2. The apparatus of claim 1, wherein the distal segment is configured to at least partially encircle the renal vasculature in the expanded treatment configuration.
 3. The apparatus of claim 1, wherein the distal segment is configured to at least partially encircle a renal artery of the patient.
 4. The apparatus of claim 1, wherein the distal segment is configured for placement in an annular space between renal fascia and renal vasculature.
 5. The apparatus of claim 1, wherein the apparatus is configured to orient a longitudinal portion of the electric field with a longitudinal dimension of at least one of the renal nerve and the renal vasculature.
 6. The apparatus of claim 1, wherein the one or more electrodes comprise a bipolar electrode pair.
 7. The apparatus of claim 1, wherein the one or more electrodes comprise an active electrode, and wherein the apparatus further comprises a ground electrode located remote from the renal nerve, such that the active electrode is configured to deliver the electric field to the renal nerve in a monopolar fashion.
 8. The apparatus of claim 7, wherein the ground electrode is configured for exterior attachment to the patient.
 9. The apparatus of claim 1, wherein the electric field generator is configured to produce a pulsed electric field that induces irreversible electroporation of the renal nerve.
 10. The apparatus of claim 1, wherein the electric field generator is configured to produce a pulsed electric field that induces electrofusion of the renal nerve.
 11. The apparatus of claim 1, wherein the one or more electrodes and the electric field generator are further configured to deliver a stimulation electric field to the renal nerve.
 12. The apparatus of claim 1, wherein the apparatus comprises an element for monitoring the response of at least one physiological parameter to stimulation of the renal nerve.
 13. The apparatus of claim 12, wherein the element is chosen from the group consisting of ultrasound sensors, electrodes, thermocouples, temperature sensors, pressure sensors, imaging modalities, electrical impedance sensors and combinations thereof.
 14. The apparatus of claim 1, wherein the one or more electrodes are chosen from the group consisting of basket-shaped electrodes, cup-shaped electrodes, spiral electrodes, helical electrodes, ring electrodes, cuff electrodes, fan-shaped electrodes, space-occupying electrodes, undulating electrodes, sinusoidal electrodes, coil electrodes, wire electrodes, arcuate electrodes, concave electrodes, curved electrodes, ribbon electrodes, braid electrodes, composite electrodes, expandable electrodes and combinations thereof.
 15. The apparatus of claim 1 wherein the apparatus further comprises an infusion element configured to create a working space to facilitate placement of the electrodes.
 16. The apparatus of claim 1 further comprising an implanted subcutaneous element electrically coupled to the electrode via tunneled leads.
 17. The apparatus of claim 16, wherein the implanted subcutaneous element comprises a subcutaneous electrical contact, the apparatus further comprising a transcutaneous probe electrically coupled to the electric field generator and configured for reversible placement across skin of the patient for electrically coupling the transcutaneous probe to the subcutaneous electrical contact.
 18. The apparatus of claim 16, wherein the implanted subcutaneous element comprises a transcutaneous energy transfer receiving element, the apparatus further comprising a transcutaneous energy transfer transmission element electrically coupled to the electric field generator and configured to non-invasively transmit energy transcutaneously to the receiving element.
 19. The apparatus of claim 16, wherein the implanted subcutaneous element comprises the electric field generator.
 20. The apparatus of claim 19, wherein the implanted subcutaneous element further comprises an energy

storage device electrically coupled to the electric field generator.

21. The apparatus of claim 20, wherein the energy storage device is configured for recharging. 5
22. The apparatus of claim 21, further comprising an external charger configured to transcutaneously recharge the energy storage device. 10
23. The apparatus of claim 20, wherein the implanted subcutaneous element further comprises a controller. 15
24. The apparatus of claim 23, wherein the controller further comprises a programmable controller. 20
25. The apparatus of claim 24, further comprising an external programmer configured to transcutaneously program the controller. 25
26. The apparatus of claim 1, wherein the guidance comprises guidance chosen from the group consisting of visual, computed tomographic, radiographic, ultrasonic, angiographic, laparoscopic, and combinations thereof. 30
27. The apparatus of claim 1, wherein the probe is electrically coupled to the electric field generator, and wherein the electrode is attached to the probe. 35
28. The apparatus of claim 1, wherein the one or more electrodes are configured for extravascular placement through the probe proximate the renal nerve. 40
29. The apparatus of claim 1, wherein the probe is chosen from the group consisting of needles, trocars and combinations thereof. 45
30. The apparatus of claim 1, further comprising a catheter configured for advancement through the probe, wherein the one or more electrodes are attached to the catheter. 50

Patentansprüche

1. Für die renale Neuromodulation, z. B. renale Dener-
vierung, konfigurierte Vorrichtung, wobei die Vor-
richtung umfasst: 50
- eine Einführsonde (220)
konfiguriert für die perkutane Einführung und ex-
travaskuläre Platzierung in der Nähe eines re-
nalen Nervs und innerhalb der Gerota-Faszie
unter Führung, und 55
- ein Elektrodenelement (230)
mit einem erweiterbaren distalen Segment mit

einer oder mehreren Elektroden, wobei das Elektrodenelement zum Vortreiben durch die Sonde konfiguriert ist, wobei das distale Segment zur Anordnung in (a) einer reduzierten Zuführkonfiguration zur Anordnung in der Nähe einer renalen Vaskulatur und (b) einer erweiterten Behandlungskonfiguration zur Zuführung des elektrischen Feldes an den renalen Nerv konfiguriert ist, und wobei das distale Segment konfiguriert ist, zu einer raumbeanspruchenden Form erweitert zu werden, und wobei die eine oder mehreren Elektroden zur elektrischen Kopplung an einen elektrischen Feldgenerator und zur Abgabe eines elektrischen Feldes an den renalen Nerv konfiguriert sind, während sie in der Nähe des renalen Nervs angeordnet sind.

2. Vorrichtung nach Anspruch 1, wobei das distale Segment so konfiguriert ist, dass es die renale Vaskulatur in der erweiterten Behandlungskonfiguration zumindest teilweise umschließt.
3. Vorrichtung nach Anspruch 1, wobei das distale Segment so konfiguriert ist, dass es eine renale Arterie des Patienten zumindest teilweise umschließt.
4. Vorrichtung nach Anspruch 1, wobei das distale Segment zur Anordnung in einem ringförmigen Raum zwischen renaler Faszie und renaler Vaskulatur konfiguriert ist.
5. Vorrichtung nach Anspruch 1, wobei die Vorrichtung zur Ausrichtung eines longitudinalen Teils des elektrischen Feldes mit einer longitudinalen Ausdehnung von mindestens einem des renalen Nervs und der renalen Vaskulatur konfiguriert ist.
6. Vorrichtung nach Anspruch 1, wobei die eine oder mehreren Elektroden ein bipolares Elektrodenpaar umfassen.
7. Vorrichtung nach Anspruch 1, wobei die eine oder mehreren Elektroden eine aktive Elektrode umfassen, und wobei die Vorrichtung weiter eine Masseelektrode umfasst, die sich entfernt vom renalen Nerv befindet, sodass die aktive Elektrode so konfiguriert ist, dass sie das elektrische Feld auf monopolare Weise an den renalen Nerv zuführt.
8. Vorrichtung nach Anspruch 7, wobei die Masseelektrode zur äußeren Anbringung am Patienten konfiguriert ist.
9. Vorrichtung nach Anspruch 1, wobei der elektrische Feldgenerator so konfiguriert ist, dass er ein gepulstes elektrisches Feld erzeugt, das irreversible Elektroporation des renalen Nervs induziert.

10. Vorrichtung nach Anspruch 1, wobei der elektrische Feldgenerator so konfiguriert ist, dass er ein gepulstes elektrisches Feld produziert, das Elektrofusion des renalen Nervs induziert.
11. Vorrichtung nach Anspruch 1, wobei die eine oder mehreren Elektroden und der elektrische Feldgenerator weiter so konfiguriert sind, dass sie dem renalen Nerv ein elektrisches Feld zur Stimulation zuführen.
12. Vorrichtung nach Anspruch 1, wobei die Vorrichtung ein Element zur Überwachung der Reaktion von mindestens einem physiologischen Parameter auf die Stimulation des renalen Nervs umfasst.
13. Vorrichtung nach Anspruch 12, wobei das Element aus der Gruppe ausgewählt wird, die aus Ultraschallsensoren, Elektroden, Thermoelementen, Temperatursensoren, Drucksensoren, Bildgebungsverfahren, elektrischen Impedanzsensoren und Kombinationen davon besteht.
14. Vorrichtung nach Anspruch 1, wobei die eine oder mehreren Elektroden aus der Gruppe ausgewählt werden, die aus korbformigen Elektroden, becherformigen Elektroden, Spiralelektroden, helixförmigen Elektroden, Ringelektroden, Manschettenelektroden, fächerförmigen Elektroden, raumbeanspruchenden Elektroden, wellenförmigen Elektroden, sinusförmigen Elektroden, Spulenelektroden, Drahtelektroden, bogenförmigen Elektroden, konkaven Elektroden, gebogenen Elektroden, Bandlektroden, Flechtelektroden, Compositelektroden, erweiterbaren Elektroden und Kombinationen davon besteht.
15. Vorrichtung nach Anspruch 1, wobei die Vorrichtung weiter ein Infusionselement umfasst, das so konfiguriert ist, dass es einen Arbeitsbereich zur Vereinfachung der Anordnung der Elektroden schafft.
16. Vorrichtung nach Anspruch 1, weiter umfassend ein implantiertes subkutanes Element, das über getunnelte Leitungen elektrisch an die Elektrode gekoppelt ist.
17. Vorrichtung nach Anspruch 16, wobei das implantierte subkutane Element einen subkutanen elektrischen Kontakt umfasst, wobei die Vorrichtung weiter eine transkutane Sonde umfasst, die elektrisch an den elektrischen Feldgenerator gekoppelt und zur reversiblen Anordnung über der Haut des Patienten zur elektrischen Kopplung der transkutanen Sonde an den subkutanen elektrischen Kontakt konfiguriert ist.
18. Vorrichtung nach Anspruch 16, wobei das implantierte subkutane Element ein transkutanes Energieübertragungsempfangelement umfasst, wobei die Vorrichtung weiter ein transkutanes Energieübertragungstransmissionselement umfasst, das elektrisch an den elektrischen Feldgenerator gekoppelt und so konfiguriert ist, dass es nicht-invasiv Energie transkutan auf das Empfangselement überträgt.
19. Vorrichtung nach Anspruch 16, wobei das implantierte subkutane Element den elektrischen Feldgenerator umfasst.
20. Vorrichtung nach Anspruch 19, wobei das implantierte subkutane Element weiter ein elektrisch an den elektrischen Feldgenerator gekoppeltes Energiespeichergerät umfasst.
21. Vorrichtung nach Anspruch 20, wobei das Energiespeichergerät zum Wiederaufladen konfiguriert ist.
22. Vorrichtung nach Anspruch 21, weiter umfassend ein externes Ladegerät, das zum transkutanen Wiederaufladen des Energiespeichergeräts konfiguriert ist.
23. Vorrichtung nach Anspruch 20, wobei das implantierte subkutane Element weiter eine Steuerung umfasst.
24. Vorrichtung nach Anspruch 23, wobei die Steuerung weiter eine programmierbare Steuerung umfasst.
25. Vorrichtung nach Anspruch 24, weiter umfassend einen externen Programmierer, der zur transkutanen Programmierung der Steuerung konfiguriert ist.
26. Vorrichtung nach Anspruch 1, wobei die Führung eine aus der Gruppe ausgewählte Führung umfasst, die aus visuell, computertomographisch, radiographisch, Ultraschall, angiographisch, laparoskopisch und Kombinationen davon besteht.
27. Vorrichtung nach Anspruch 1, wobei die Sonde elektrisch an den elektrischen Feldgenerator gekoppelt ist, und wobei die Elektrode an der Sonde befestigt ist.
28. Vorrichtung nach Anspruch 1, wobei die eine oder mehreren Elektroden zur extravaskulären Anordnung durch die Sonde in der Nähe des renalen Nervs konfiguriert sind.
29. Vorrichtung nach Anspruch 1, wobei die Sonde aus der Gruppe ausgewählt wird, die aus Nadeln, Trokaren und Kombinationen davon besteht.
30. Vorrichtung nach Anspruch 1, weiter umfassend einen zum Vortreiben durch die Sonde konfigurierten

Katheter, wobei die eine oder mehreren Elektroden am Katheter befestigt sind.

Revendications

1. Appareil configuré pour la neuromodulation rénale, par exemple la dénervation rénale, l'appareil comprenant :

une sonde d'introduction (220) configurée pour l'insertion percutanée et le placement extravasculaire à proximité d'un nerf rénal et au sein du fascia de Gerota sous guidage, et un élément d'électrode (230) avec un segment distal extensible ayant une ou plusieurs électrodes, dans lequel l'élément d'électrode est configuré pour l'avancement à travers la sonde, dans lequel le segment distal est configuré pour être arrangé dans (a) une configuration de mise en place à profil réduit pour le placement adjacent à un réseau vasculaire rénal et (b) une configuration de traitement déployé pour administrer le champ électrique au nerf rénal, et dans lequel le segment distal est configuré pour être étendu en une forme occupant l'espace, et dans lequel lesdites une ou plusieurs électrodes sont configurées pour être électriquement couplées à un générateur de champ électrique, et pour administrer un champ électrique au nerf rénal pendant qu'il se trouve à proximité du nerf rénal.

2. Appareil selon la revendication 1, dans lequel le segment distal est configuré pour entourer au moins partiellement le réseau vasculaire rénal dans la configuration de traitement déployé.
3. Appareil selon la revendication 1, dans lequel le segment distal est configuré pour entourer au moins partiellement une artère rénale du patient.
4. Appareil selon la revendication 1, dans lequel le segment distal est configuré pour le placement dans un espace annulaire entre le fascia rénal et le réseau vasculaire rénal.
5. Appareil selon la revendication 1, dans lequel l'appareil est configuré pour orienter une portion longitudinale du champ électrique avec une dimension longitudinale d'au moins l'un du nerf rénal et du réseau vasculaire rénal.
6. Appareil selon la revendication 1, dans lequel lesdites une ou plusieurs électrodes comprennent une paire d'électrodes bipolaires.
7. Appareil selon la revendication 1, dans lequel lesdi-

tes une ou plusieurs électrodes comprennent une électrode active, et dans lequel l'appareil comprend en outre une électrode de masse localisée à distance du nerf rénal, de telle sorte que l'électrode active est configurée pour administrer le champ électrique au nerf rénal suivant un mécanisme monopolaire.

8. Appareil selon la revendication 7, dans lequel l'électrode de masse est configurée pour la fixation extérieure sur le patient.
9. Appareil selon la revendication 1, dans lequel le générateur de champ électrique est configuré pour produire un champ électrique à impulsions qui induit une électroporation irréversible du nerf rénal.
10. Appareil selon la revendication 1, dans lequel le générateur de champ électrique est configuré pour produire un champ électrique à impulsions qui induit une électrofusion du nerf rénal.
11. Appareil selon la revendication 1, dans lequel lesdites une ou plusieurs électrodes et le générateur de champ électrique sont en outre configurés pour administrer un champ électrique de stimulation au nerf rénal.
12. Appareil selon la revendication 1, dans lequel l'appareil comprend un élément pour surveiller la réponse d'au moins un paramètre physiologique à la stimulation du nerf rénal.
13. Appareil selon la revendication 12, dans lequel l'élément est choisi dans le groupe comprenant des capteurs ultrasonores, des électrodes, des thermocouples, des capteurs de température, des capteurs de pression, des modalités d'imagerie, des capteurs d'impédance électrique et des combinaisons de ceux-ci.
14. Appareil selon la revendication 1, dans lequel lesdites une ou plusieurs électrodes sont choisies dans le groupe comprenant des électrodes en forme de panier, des électrodes en forme de coupelles, des électrodes spiralées, des électrodes hélicoïdales, des électrodes annulaires, des électrodes souples, des électrodes en forme d'éventail, des électrodes occupant l'espace, des électrodes ondulantes, des électrodes sinusoïdales, des fils-électrodes, des électrodes en fil, des électrodes arquées, des électrodes concaves, des électrodes courbes, des électrodes en ruban, des électrodes tressées, des électrodes composites, des électrodes extensibles et des combinaisons de celles-ci.
15. Appareil selon la revendication 1, dans lequel l'appareil comprend en outre un élément de perfusion configuré pour créer un espace de travail afin de

- faciliter le placement des électrodes.
- 16.** Appareil selon la revendication 1, comprenant en outre un élément sous-cutané implanté électriquement couplé à l'électrode par l'intermédiaire de dérivations formant un tunnel. 5
- 17.** Appareil selon la revendication 16, dans lequel l'élément sous-cutané implanté comprend un contact électrique sous-cutané, l'appareil comprenant en outre une sonde transcutanée électriquement couplée au générateur de champ électrique et configurée pour le placement réversible sur la peau du patient pour le couplage électrique de la sonde transcutanée au contact électrique sous-cutané. 10
- 18.** Appareil selon la revendication 16, dans lequel l'élément sous-cutané implanté comprend un élément de réception du transfert d'énergie transcutané, l'appareil comprenant en outre un élément de transmission du transfert d'énergie transcutané électriquement couplé au générateur de champ électrique et configuré pour transmettre de manière non invasive l'énergie par voie transcutanée à l'élément de réception. 15
- 19.** Appareil selon la revendication 16, dans lequel l'élément sous-cutané implanté comprend le générateur de champ électrique. 20
- 20.** Appareil selon la revendication 19, dans lequel l'élément sous-cutané implanté comprend en outre un dispositif de stockage d'énergie électriquement couplé au générateur de champ électrique. 25
- 21.** Appareil selon la revendication 20, dans lequel le dispositif de stockage d'énergie est configuré pour la recharge. 30
- 22.** Appareil selon la revendication 21, comprenant en outre un chargeur externe configuré pour recharger par voie transcutanée le dispositif de stockage d'énergie. 35
- 23.** Appareil selon la revendication 20, dans lequel l'élément sous-cutané implanté comprend en outre un contrôleur. 40
- 24.** Appareil selon la revendication 23, dans lequel le contrôleur comprend en outre un contrôleur programmable. 45
- 25.** Appareil selon la revendication 24, comprenant en outre un programmeur externe configuré pour programmer par voie transcutanée le contrôleur. 50
- 26.** Appareil selon la revendication 1, dans lequel le guidage comprend le guidage choisi dans le groupe comprenant le guidage visuel, tomographique informatisé, radiographique, ultrasonore, angiographique, laparoscopique, et des combinaisons de ceux-ci. 55
- 27.** Appareil selon la revendication 1, dans lequel la sonde est électriquement couplée au générateur de champ électrique, et dans lequel l'électrode est fixée à la sonde.
- 28.** Appareil selon la revendication 1, dans lequel lesdites une ou plusieurs électrodes sont configurées pour le placement extravasculaire à travers la sonde à proximité du nerf rénal.
- 29.** Appareil selon la revendication 1, dans lequel la sonde est choisie dans le groupe comprenant des aiguilles, des trocarts et des combinaisons de ceux-ci.
- 30.** Appareil selon la revendication 1, comprenant en outre un cathéter configuré pour l'avancement à travers la sonde, dans lequel lesdites une ou plusieurs électrodes sont fixées au cathéter.

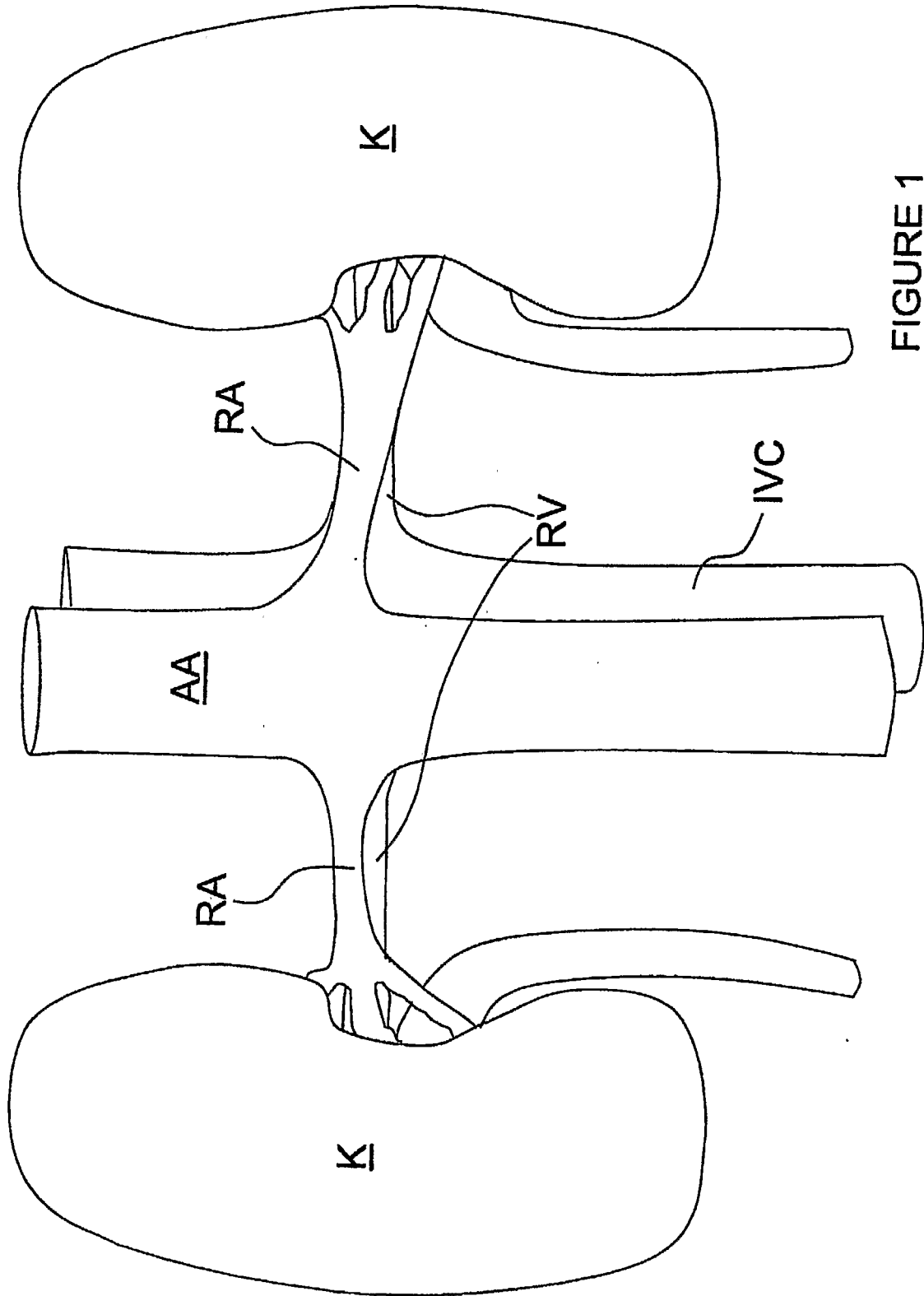

FIGURE 1

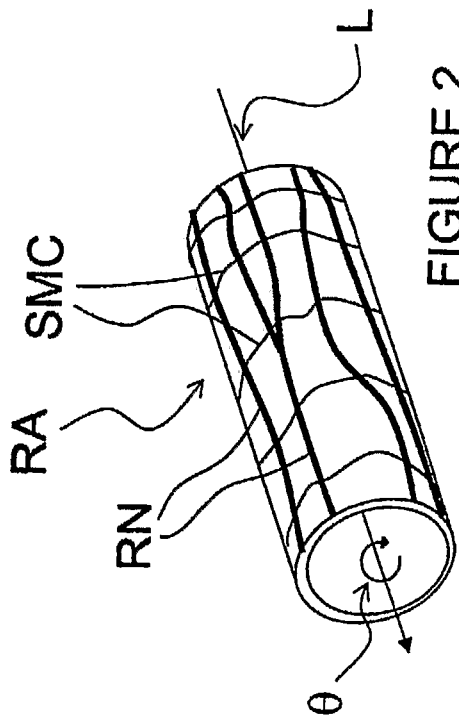

FIGURE 2

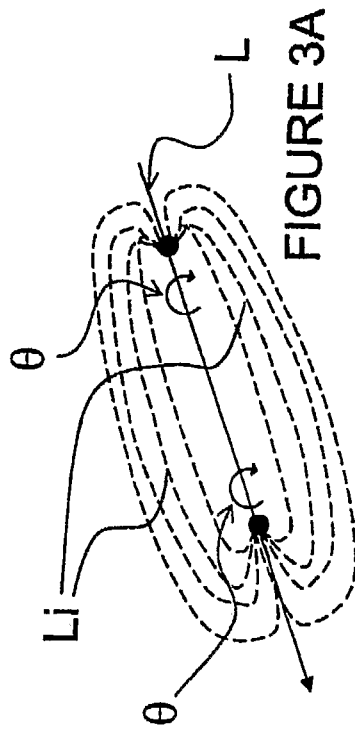

FIGURE 3A

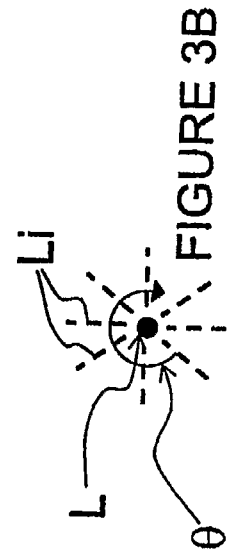

FIGURE 3B

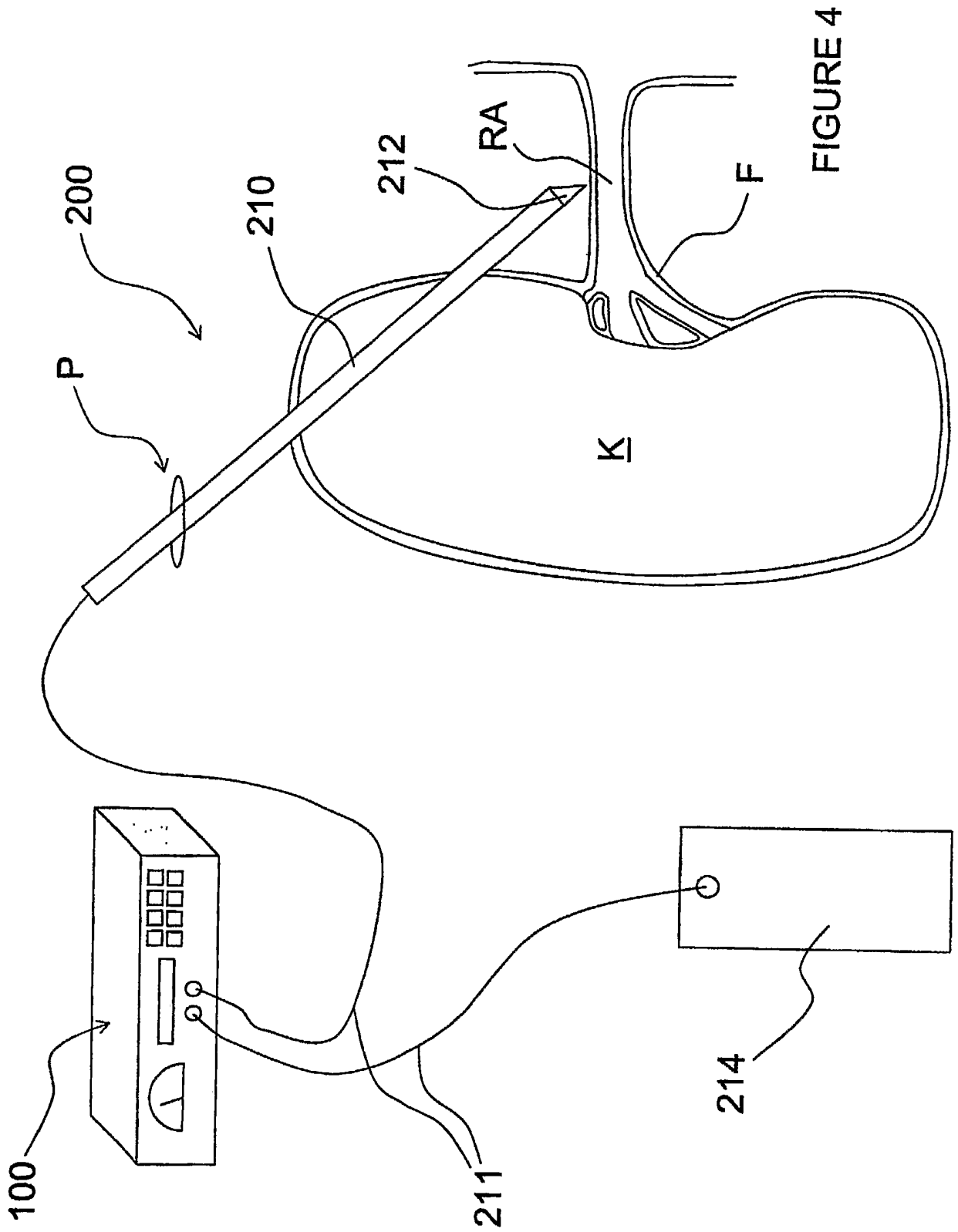

FIGURE 4

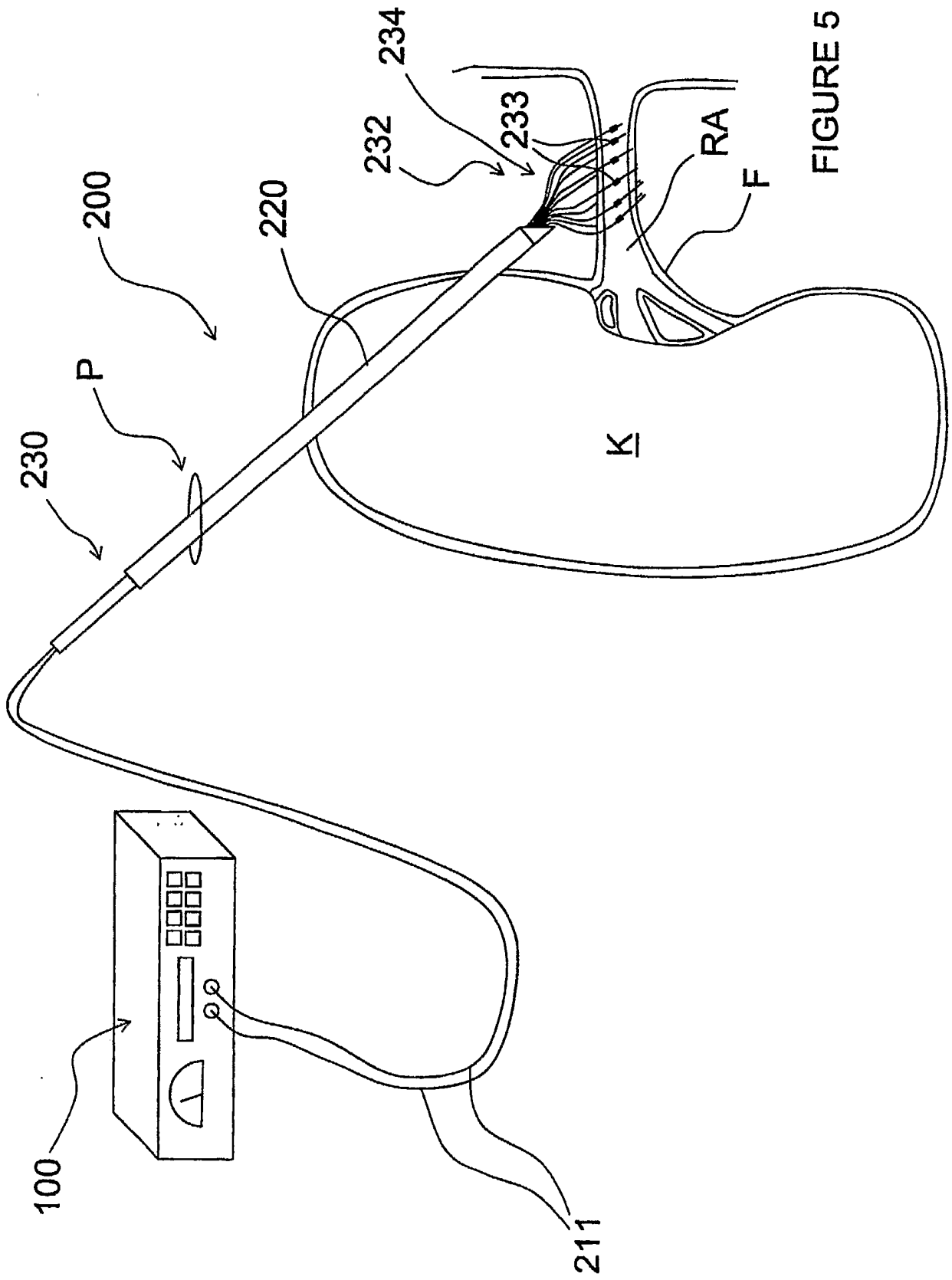
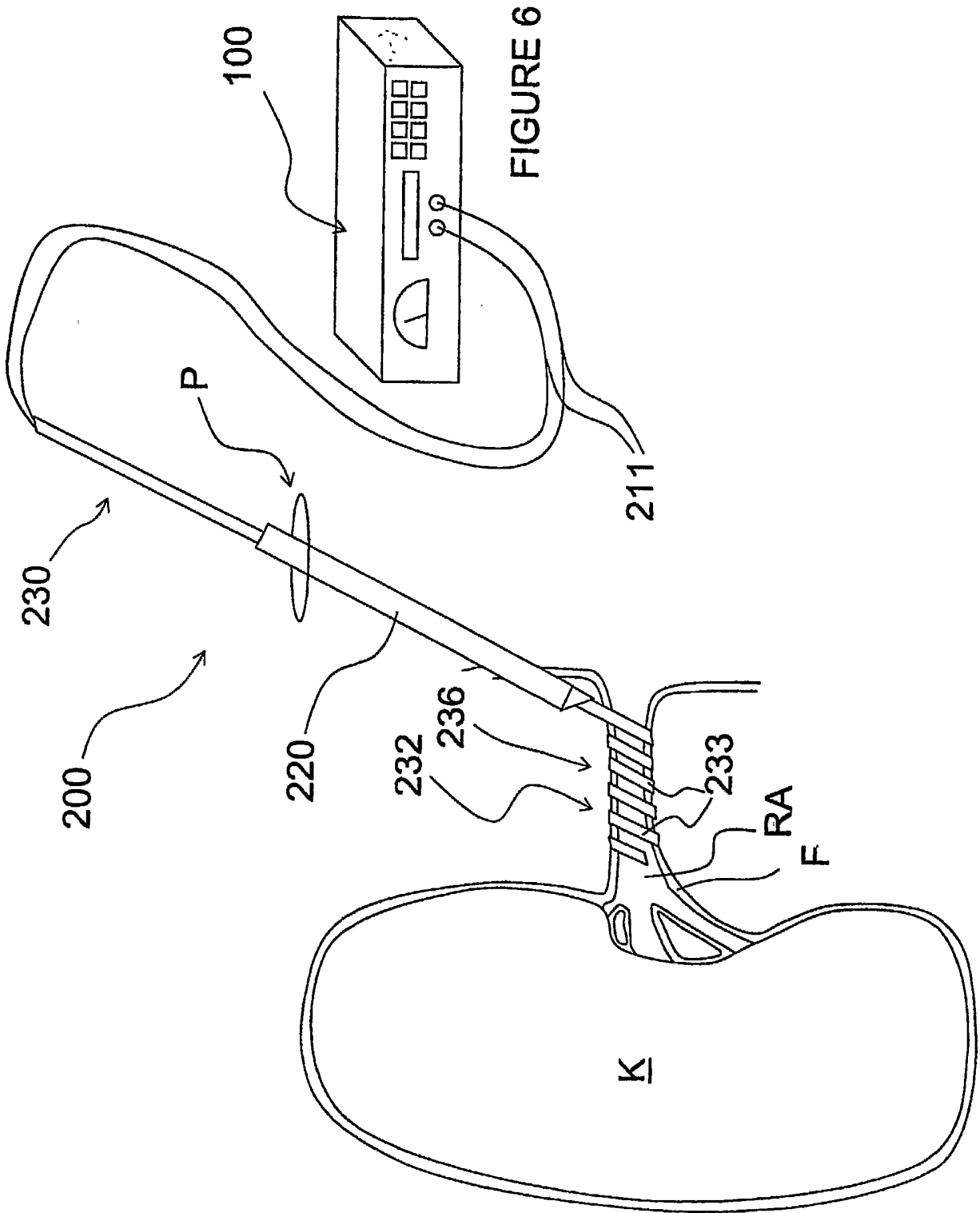

FIGURE 5



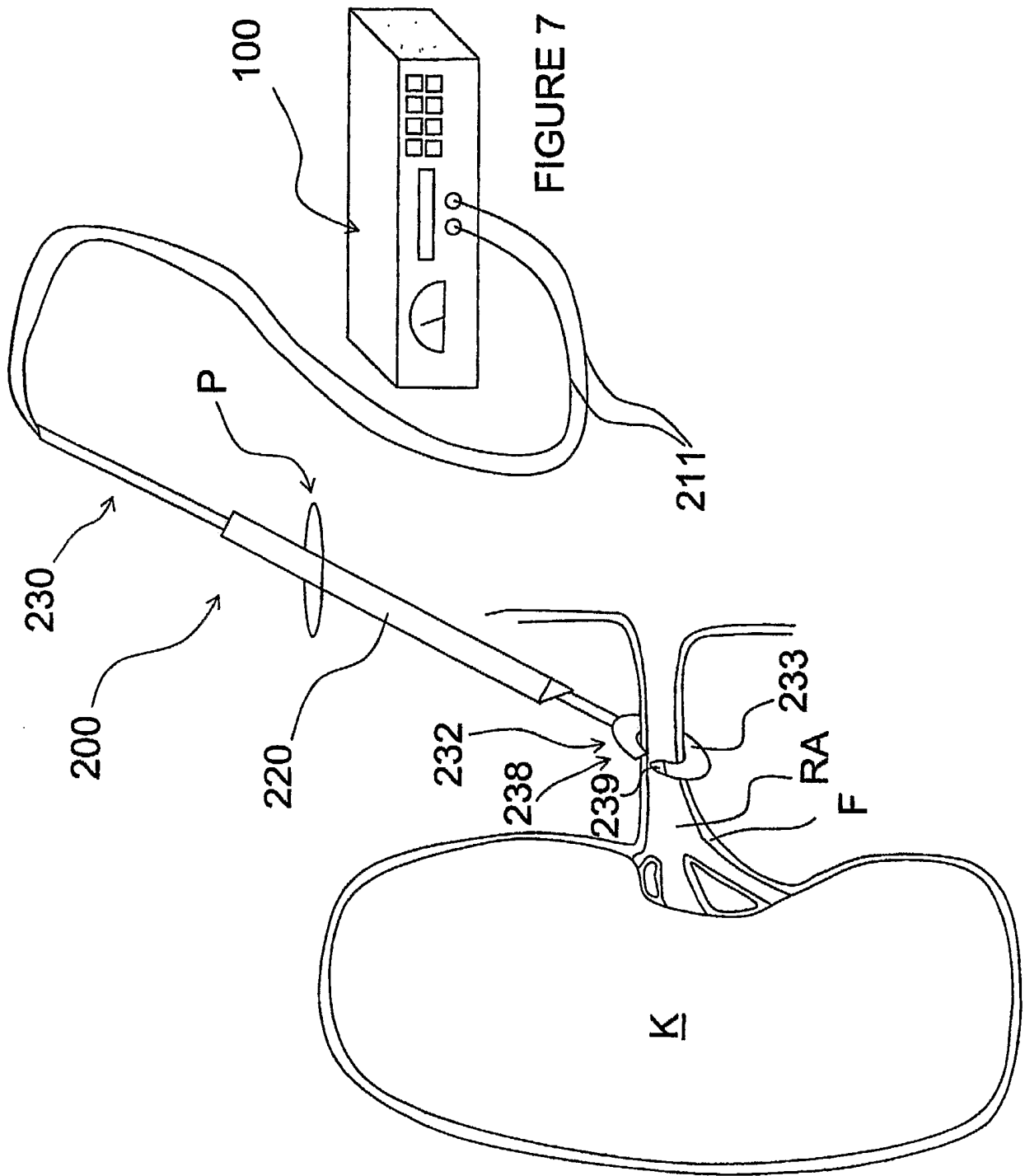
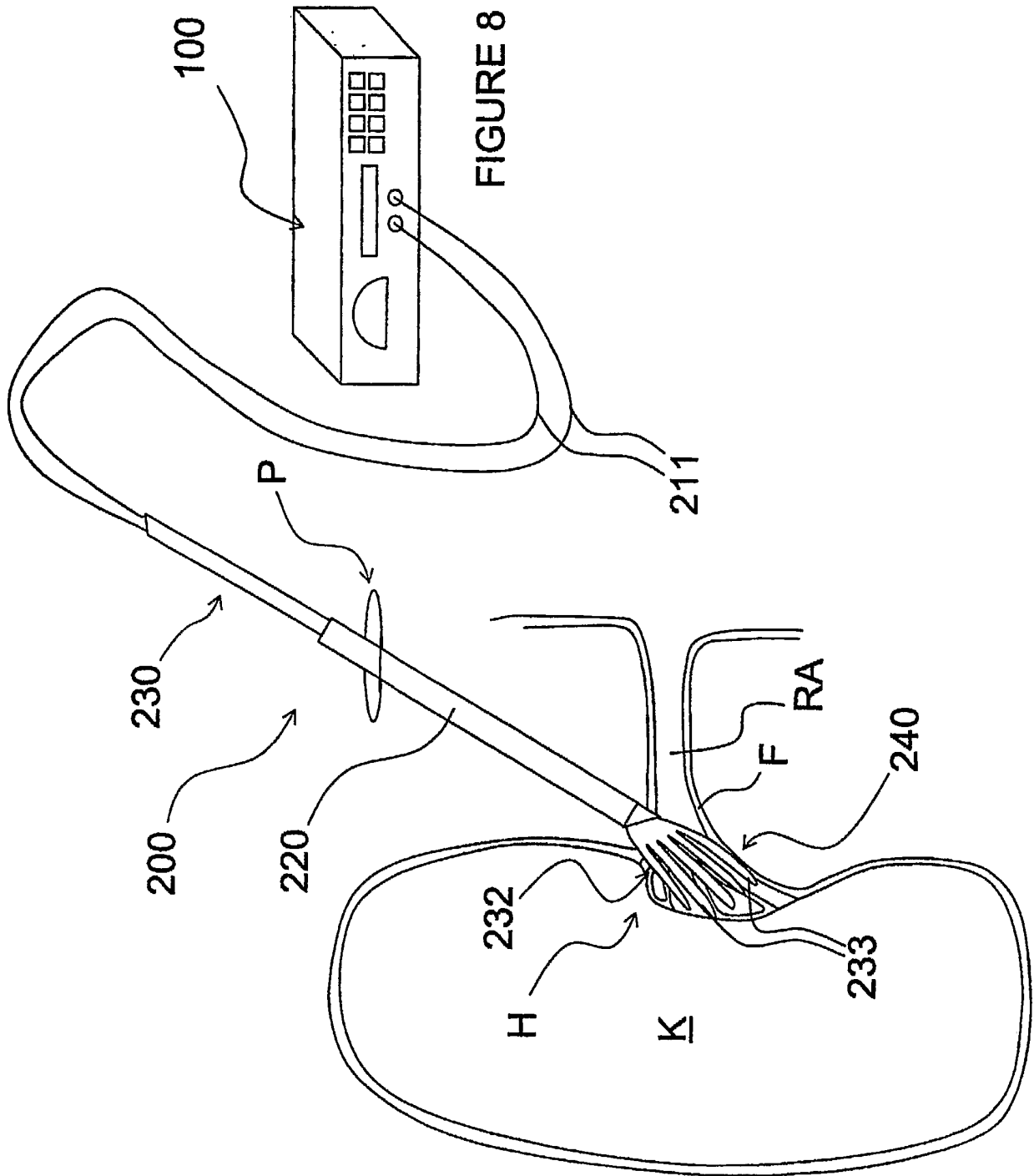
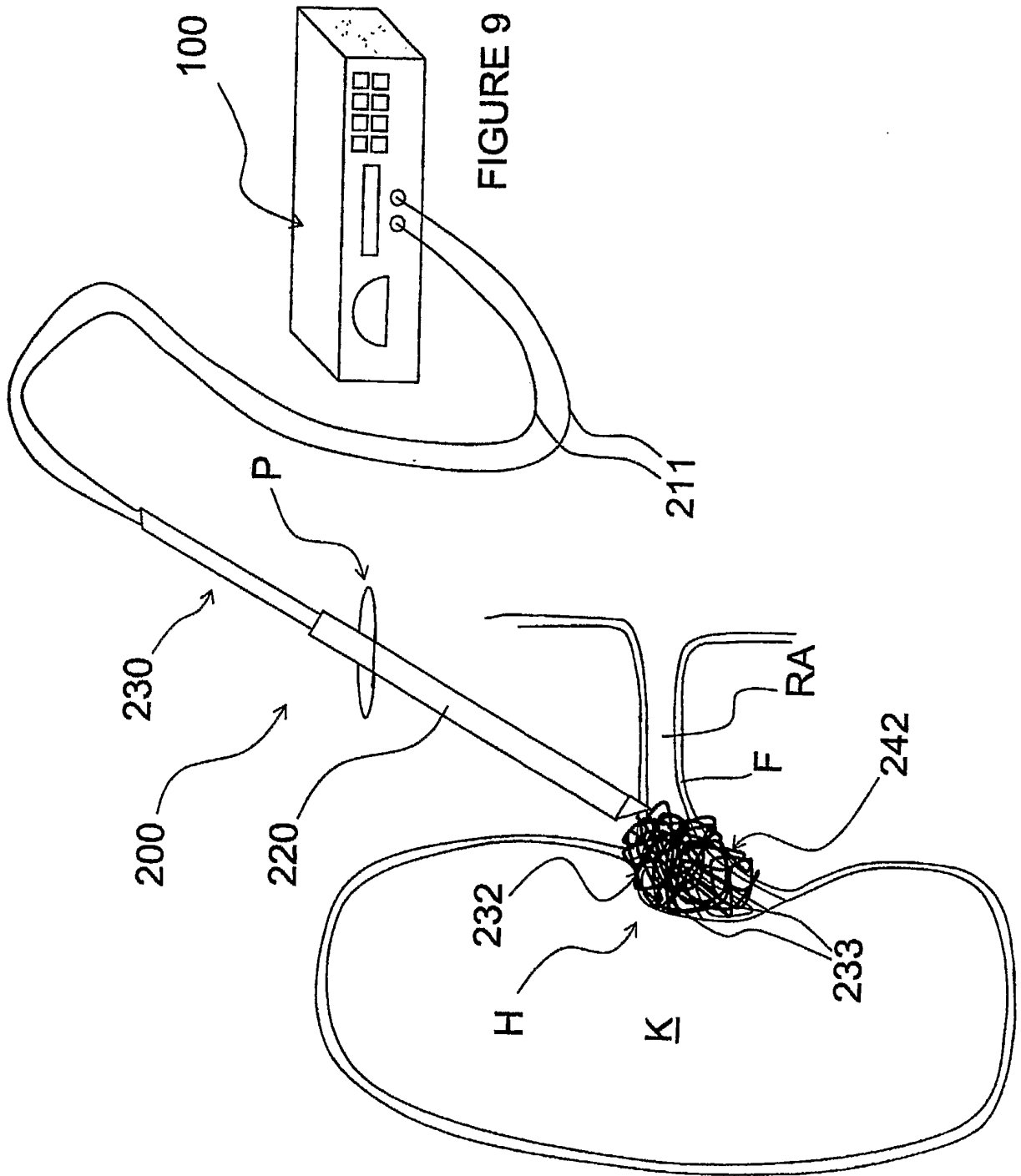

FIGURE 7





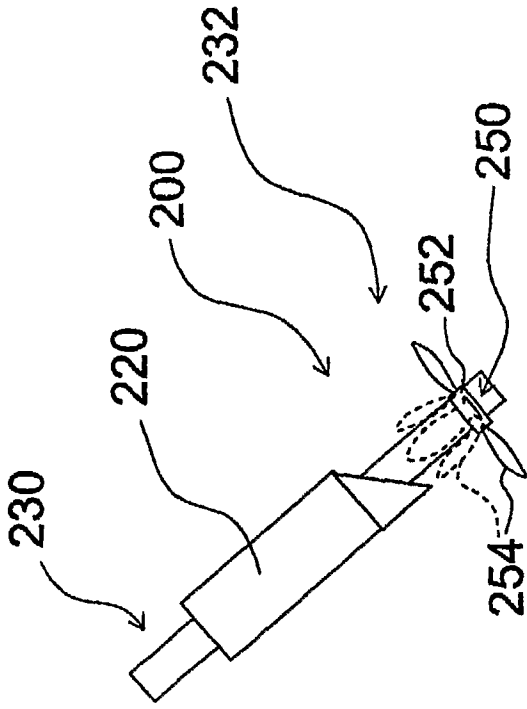

FIGURE 11A

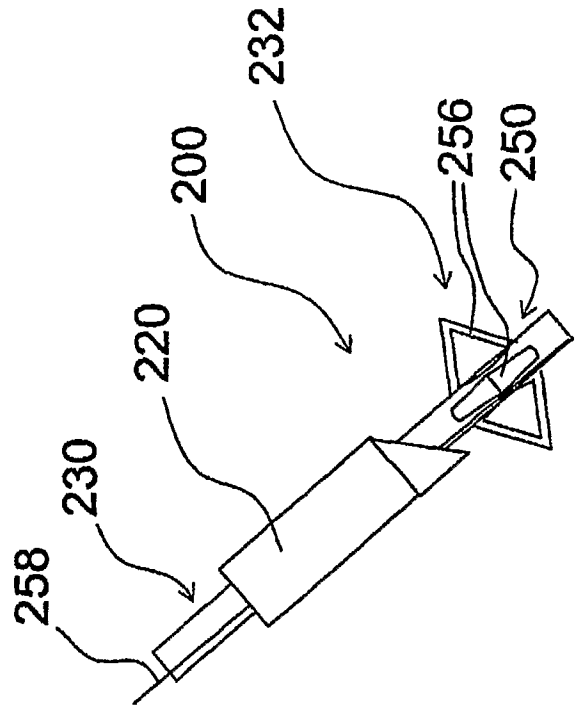

FIGURE 11B

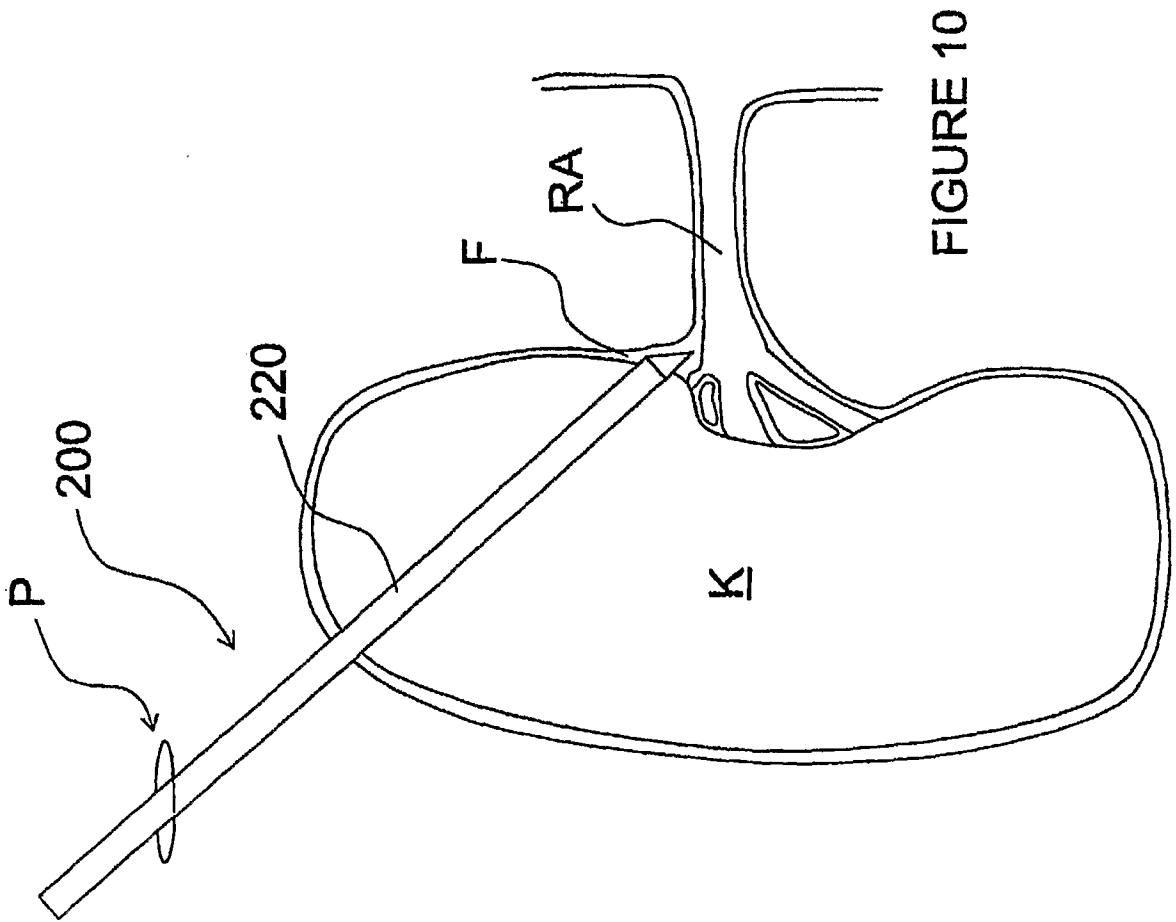

FIGURE 10

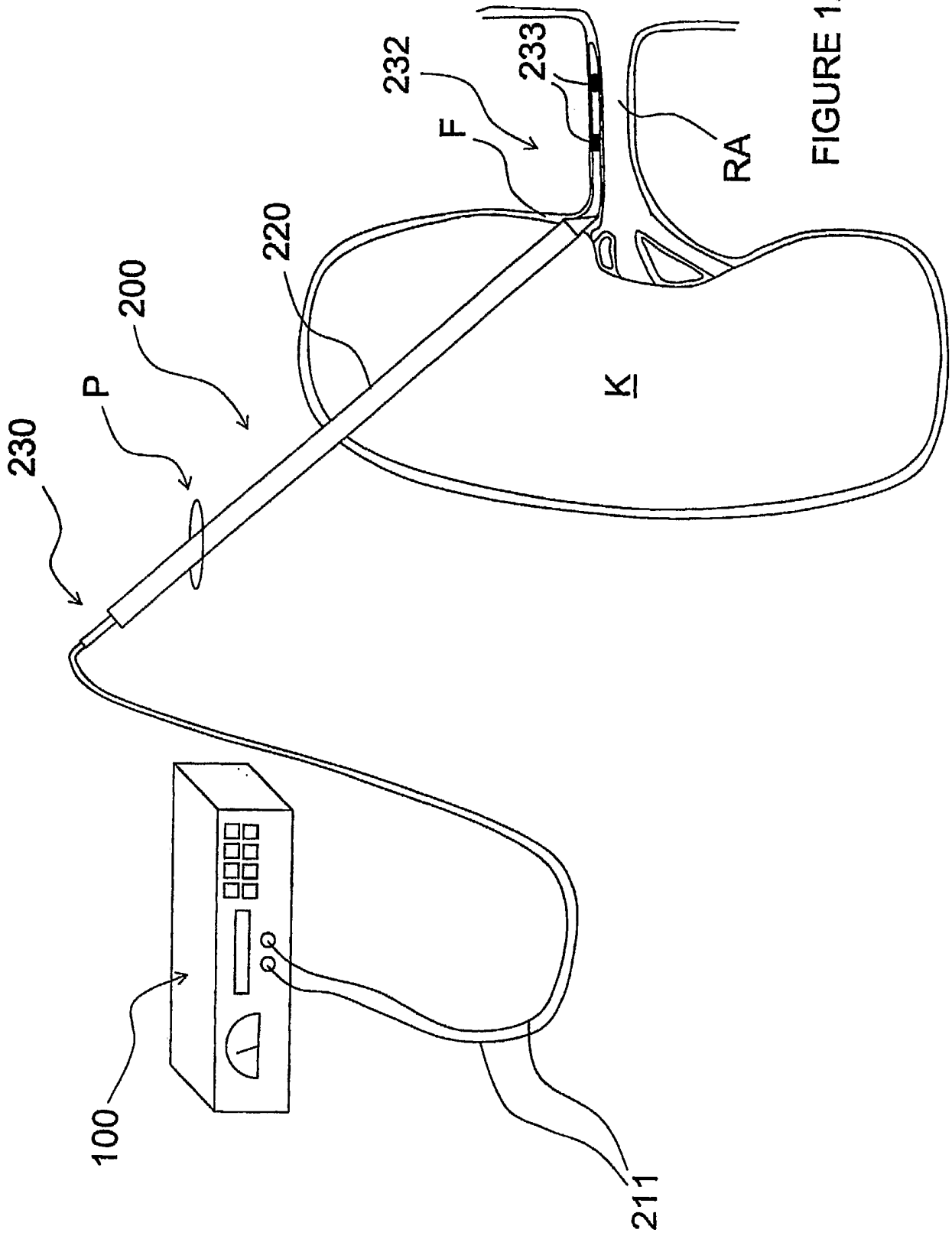

FIGURE 12

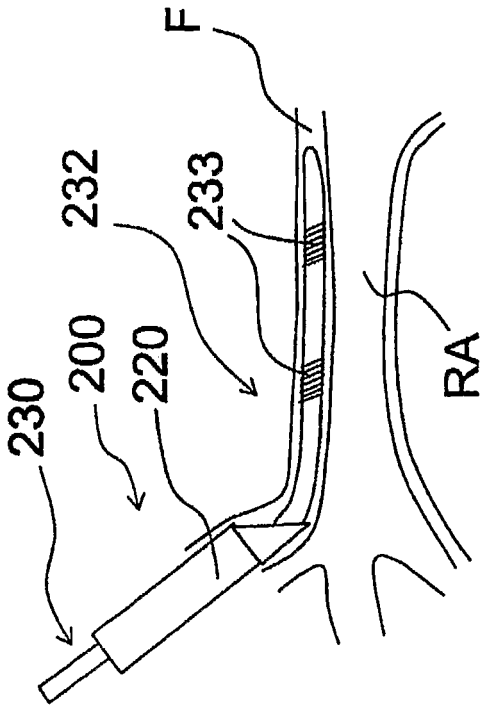

FIGURE 13A

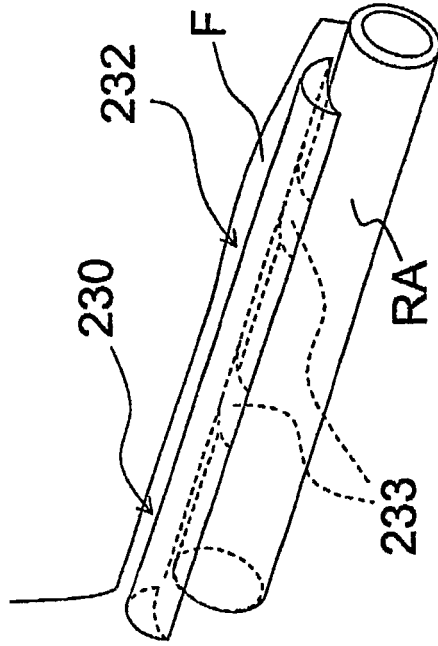

FIGURE 13C

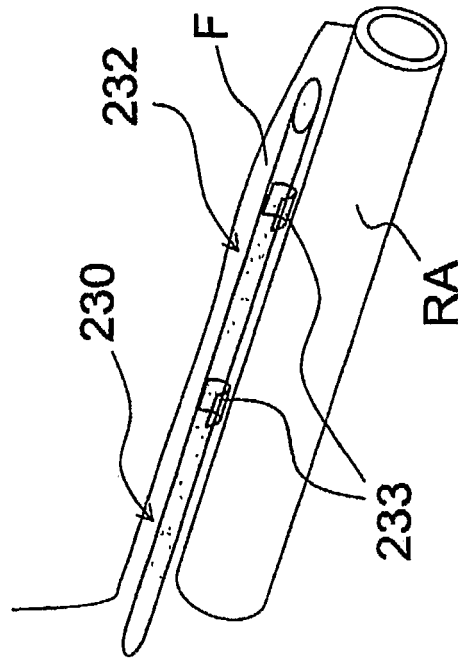

FIGURE 13B

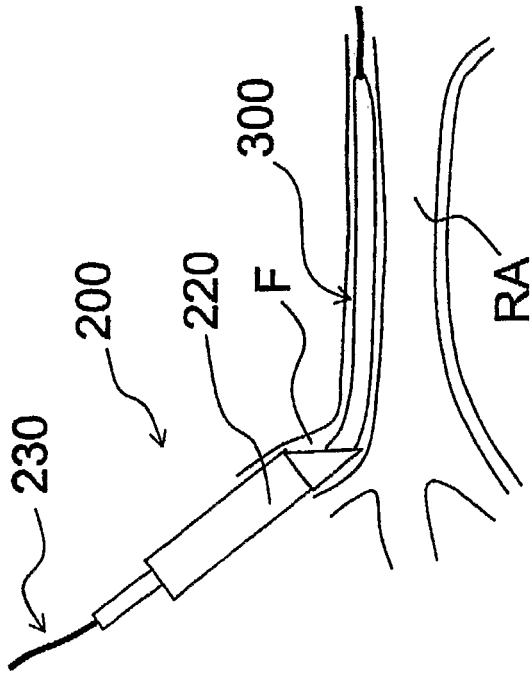

FIGURE 14A

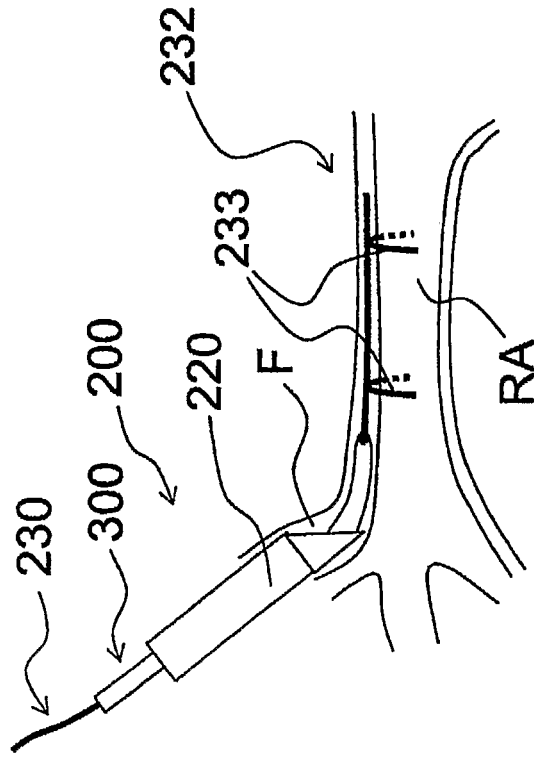

FIGURE 14B

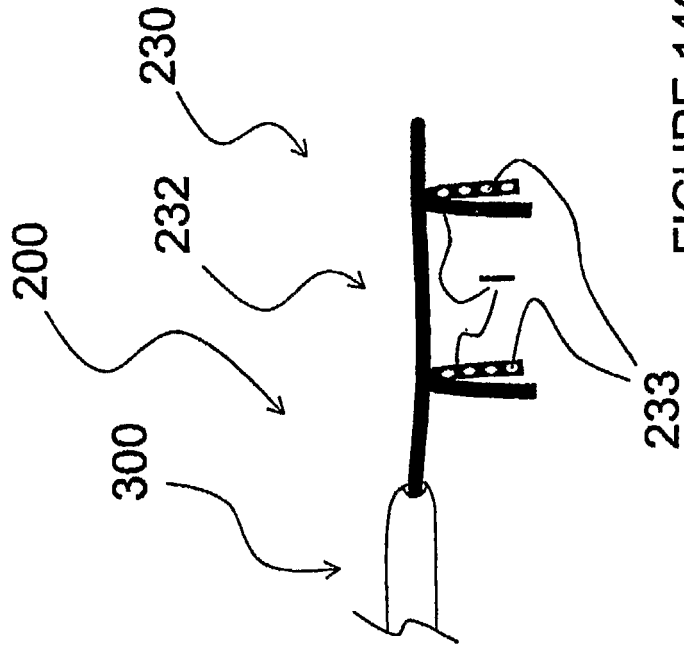

FIGURE 14C

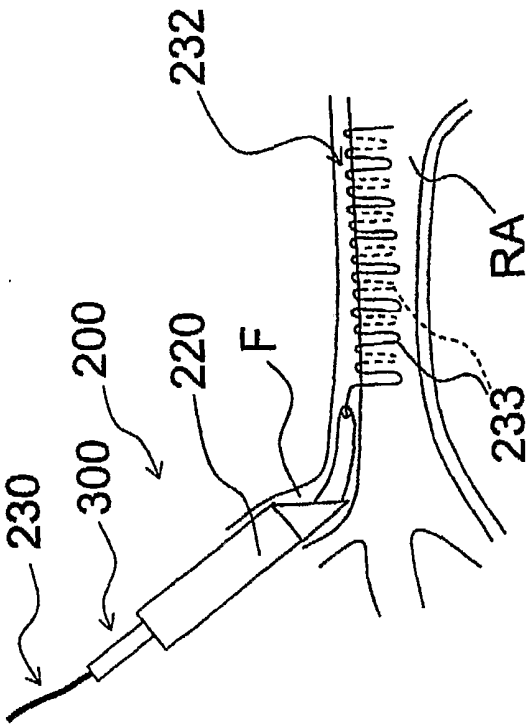

FIGURE 15A

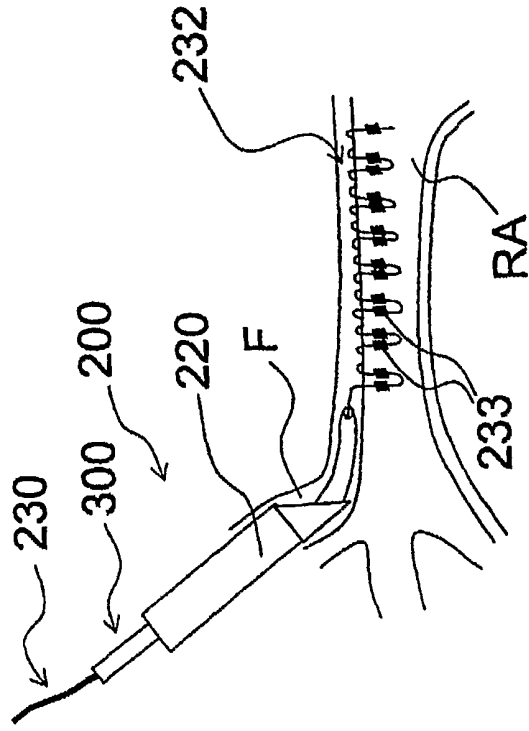

FIGURE 15B

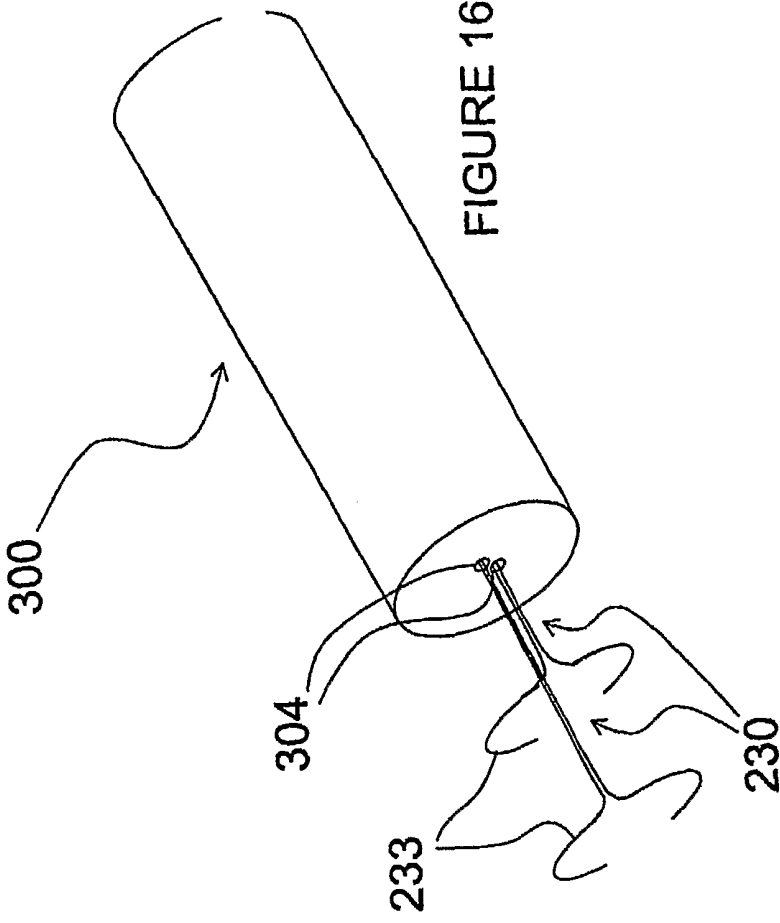
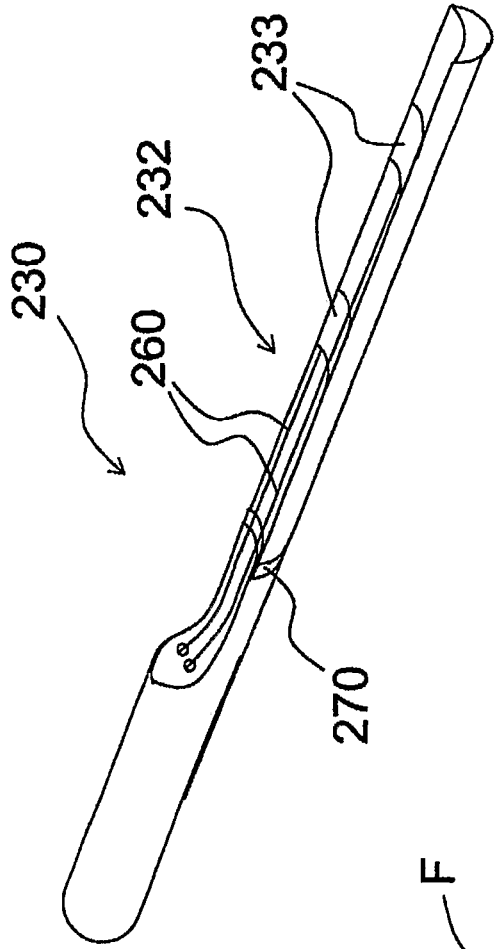
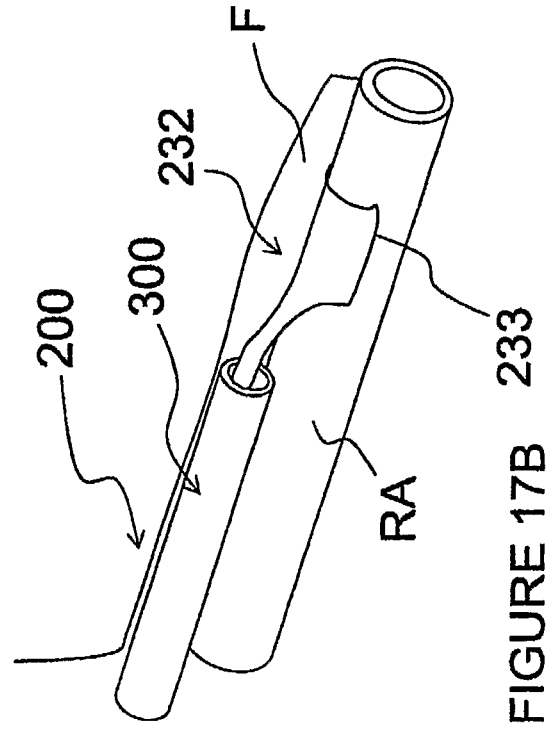
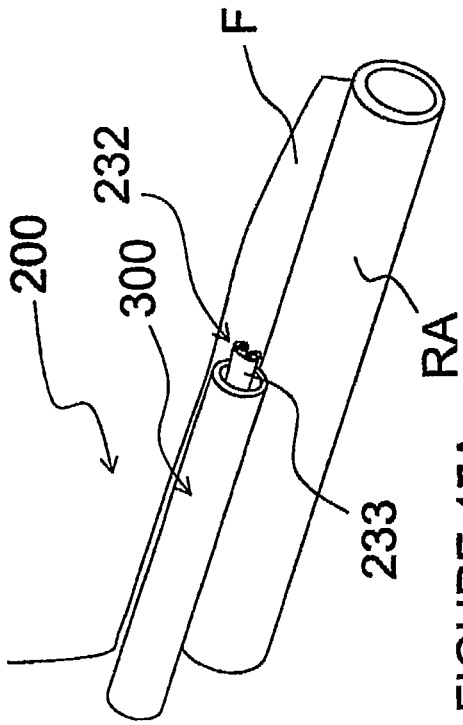

FIGURE 16



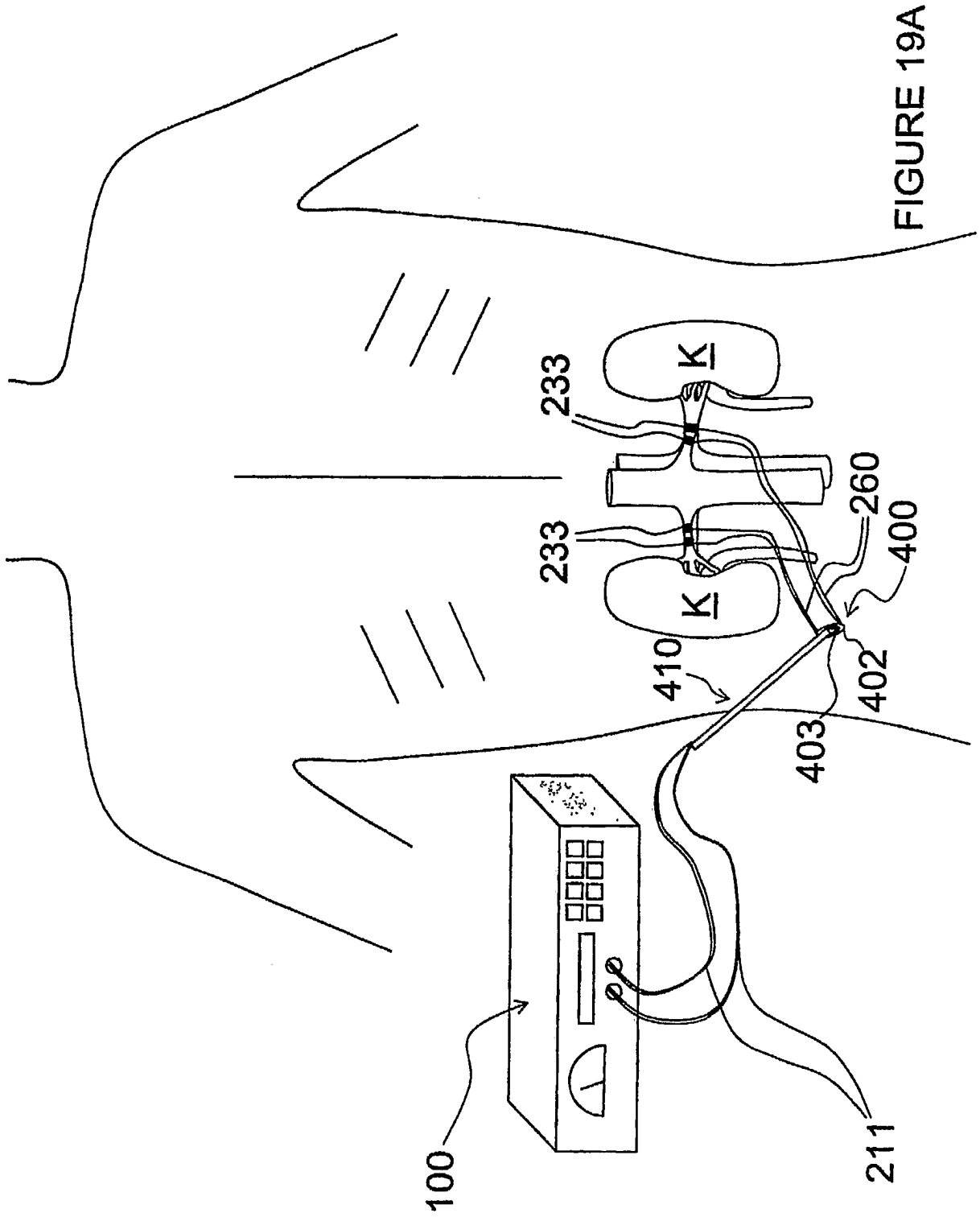

FIGURE 19A

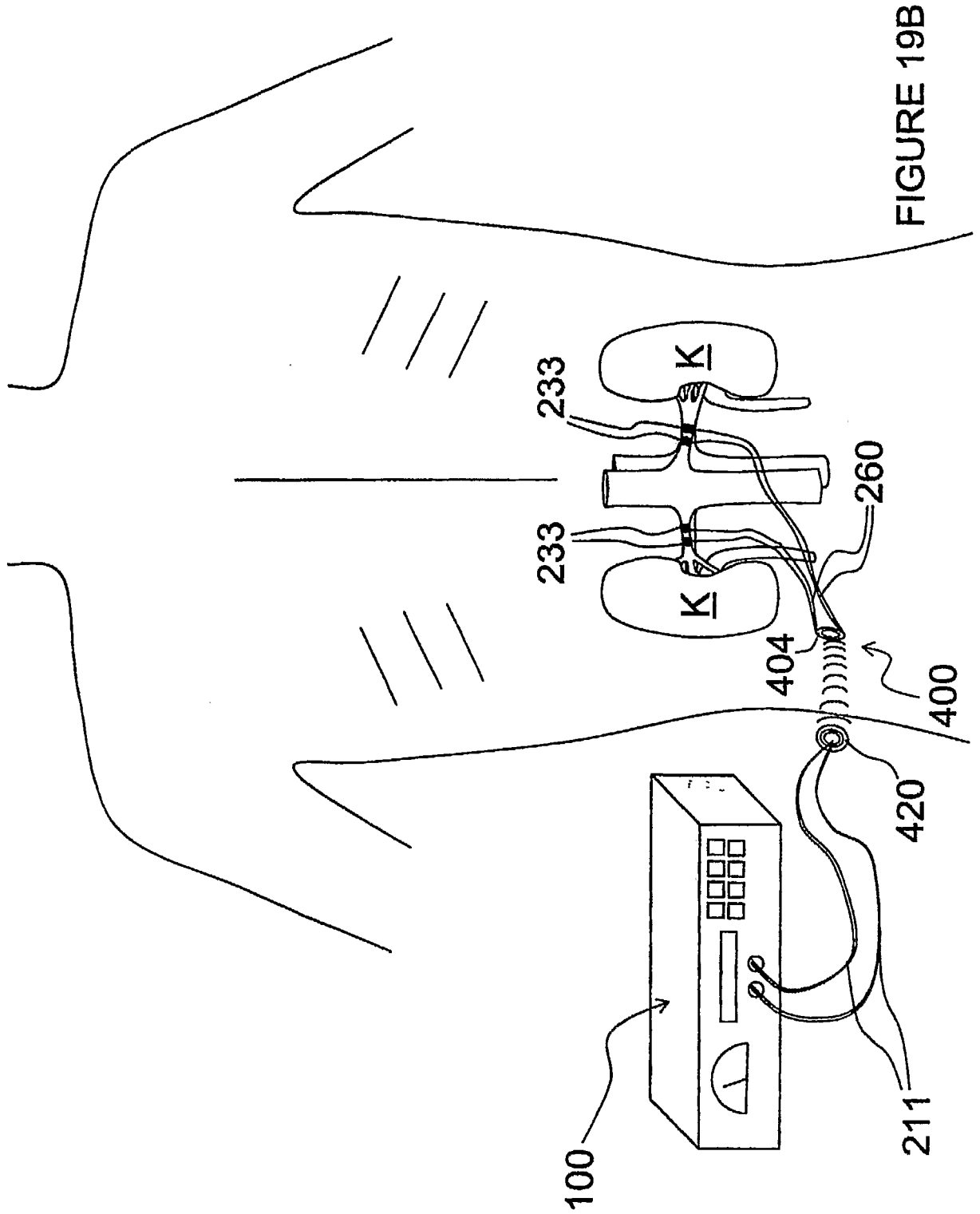
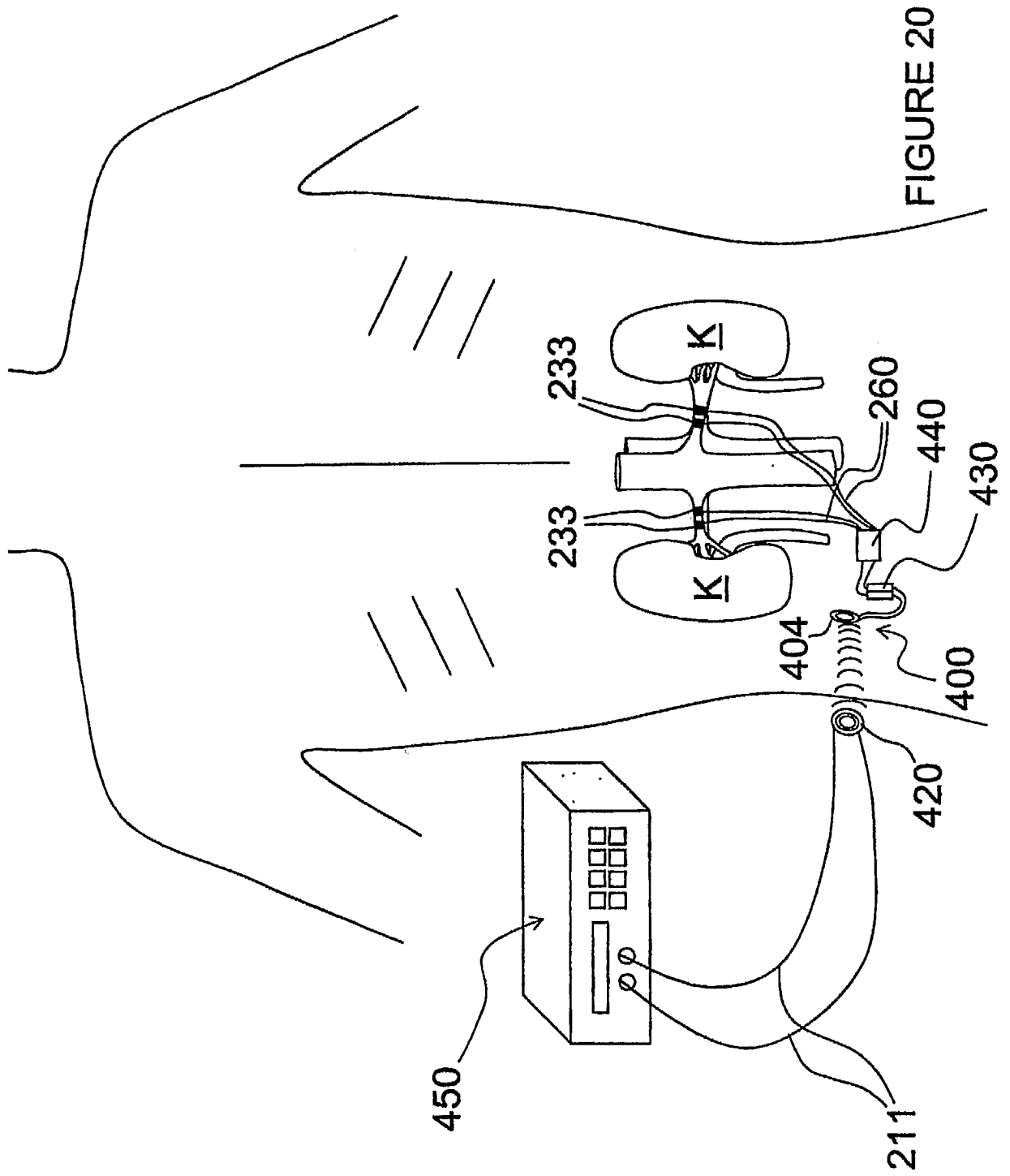
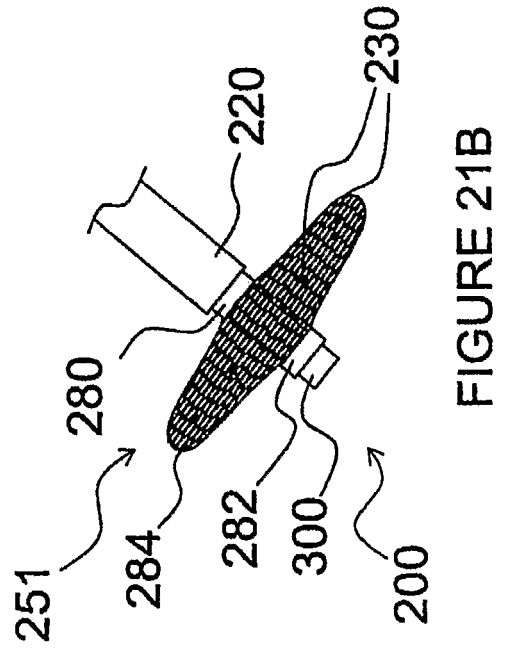
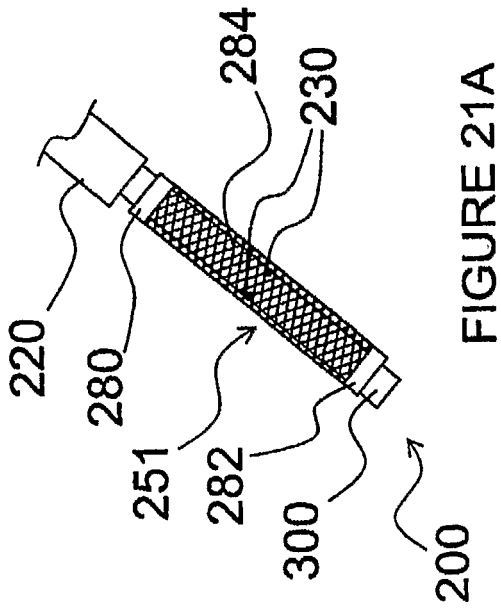
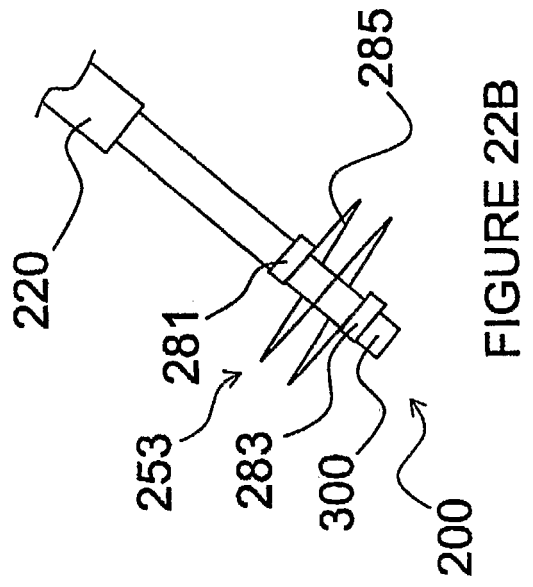
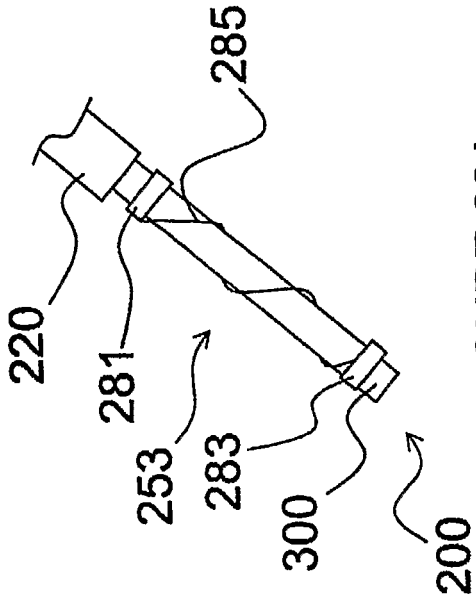

FIGURE 19B





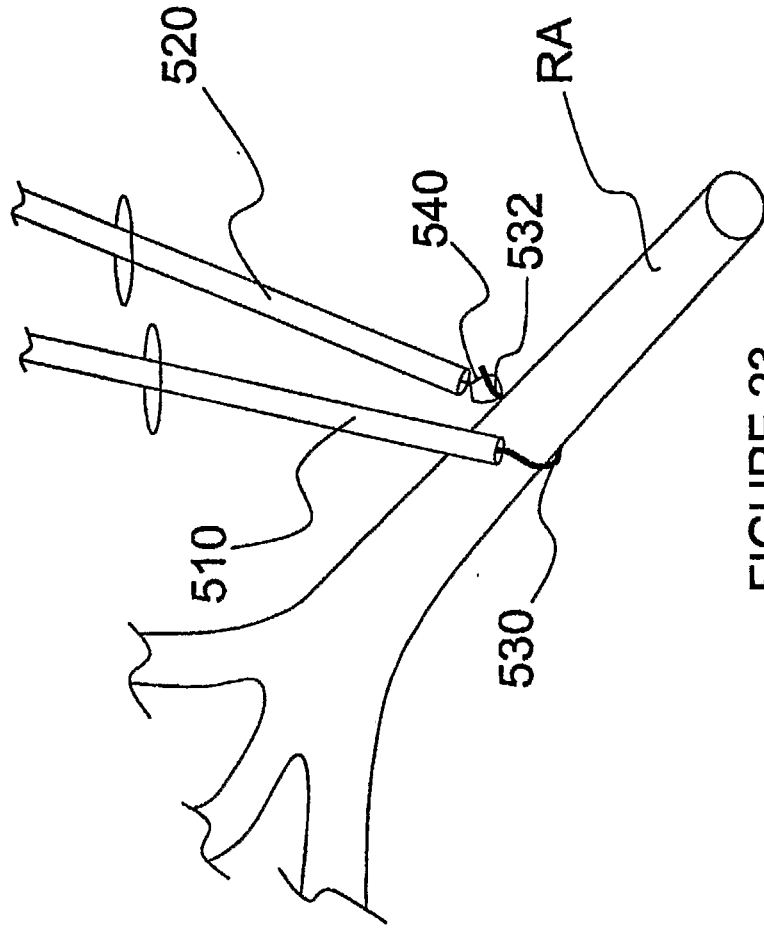

FIGURE 23

REFERENCES CITED IN THE DESCRIPTION

This list of references cited by the applicant is for the reader's convenience only. It does not form part of the European patent document. Even though great care has been taken in compiling the references, errors or omissions cannot be excluded and the EPO disclaims all liability in this regard.

Patent documents cited in the description

- US 6219577 B [0030]

专利名称(译)	用于肾神经调节的装置		
公开(公告)号	EP1804905B1	公开(公告)日	2016-02-17
申请号	EP2005811851	申请日	2005-10-04
[标]申请(专利权)人(译)	ARDIAN		
申请(专利权)人(译)	ARDIAN INC.		
当前申请(专利权)人(译)	美敦力公司ARDIAN卢森堡S.A.R.L.		
[标]发明人	DEEM MARK GELFAND MARK DEMARAIS DENISE GIFFORD HANSON III LEVIN HOWARD R SUTTON DOUGLAS CLARK BENJAMIN J		
发明人	DEEM, MARK GELFAND, MARK DEMARAIS, DENISE GIFFORD, HANSON, III LEVIN, HOWARD, R. SUTTON, DOUGLAS CLARK, BENJAMIN, J.		
IPC分类号	A61N1/36 A61B18/14 A61N1/05 A61N1/32		
CPC分类号	A61N1/36007 A61B18/1492 A61B2018/00214 A61B2018/00404 A61B2018/00434 A61B2018/00511 A61N1/0551 A61N1/0558 A61N1/327 A61N1/36114 A61N1/36117		
优先权	11/189563 2005-07-25 US 60/616254 2004-10-05 US 60/624793 2004-11-02 US 11/129765 2005-05-13 US		
其他公开文献	EP1804905A4 EP1804905A1		
外部链接	Espacenet		

摘要(译)

提供了使用脉冲电场进行肾神经调节以实现电穿孔或电融合的方法和装置 (232)。预期肾神经调节 (例如, 去神经支配) 可以减少急性心肌梗塞的扩张, 减少或防止伴随充血性心力衰竭的形态变化的发生, 和/或有效治疗充血性心力衰竭。晚期肾脏疾病。本发明的实施例被配置用于脉冲外电场的血管外输送以实现神经调节。

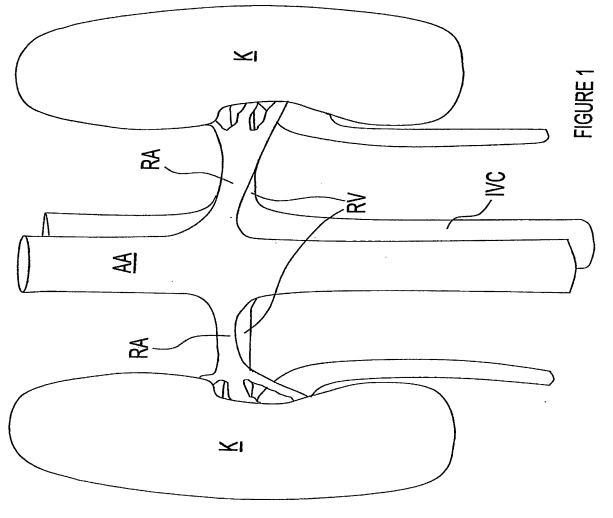

FIGURE 1