

(19)



(11)

**EP 1 689 307 B1**

(12)

**EUROPEAN PATENT SPECIFICATION**

(45) Date of publication and mention of the grant of the patent:  
**10.03.2010 Bulletin 2010/10**

(51) Int Cl.:  
**A61B 18/18 (2006.01) A61B 18/14 (2006.01)**

(21) Application number: **04819100.1**

(86) International application number:  
**PCT/US2004/037680**

(22) Date of filing: **10.11.2004**

(87) International publication number:  
**WO 2005/048863 (02.06.2005 Gazette 2005/22)**

(54) **THERMAL CAUTERY DEVICES WITH IMPROVED HEATING PROFILES**

THERMISCHE KAUSTIKVORRICHTUNGEN MIT VERBESSERTEN HEIZPROFILEN

DISPOSITIFS DE CAUTERISATION THERMIQUE A PROFILS DE CHAUFFAGE AMELIORES

(84) Designated Contracting States:  
**AT BE BG CH CY CZ DE DK EE ES FI FR GB GR HU IE IS IT LI LU MC NL PL PT RO SE SI SK TR**

- **BOUDIN, Donielle**  
Saratoga, CA 95070 (US)
- **CARLOTTO, Peter**  
Saratoga, CA 95070 (US)
- **LE, Huy**  
Saratoga, CA 95070 (US)

(30) Priority: **14.11.2003 US 713490**  
**14.11.2003 US 713341**

(74) Representative: **Nordic Patent Service**  
**Pilestræde 58**  
**1112 Copenhagen K (DK)**

(43) Date of publication of application:  
**16.08.2006 Bulletin 2006/33**

(73) Proprietor: **Starion Instruments Corporation**  
**Saratoga, CA 95070 (US)**

(56) References cited:  
**EP-A- 0 170 482 WO-A-02/087454**  
**US-A- 4 686 980 US-A- 5 496 317**  
**US-A- 5 704 377 US-A- 5 766 166**  
**US-A- 5 893 846 US-A1- 2003 109 876**  
**US-B1- 6 221 069**

(72) Inventors:  

- **MCGAFFIGAN, Thomas, H.**  
Saratoga, CA 95070 (US)
- **ECHEVERRY, Jan, M.**  
Saratoga, CA 95070 (US)

**EP 1 689 307 B1**

Note: Within nine months of the publication of the mention of the grant of the European patent in the European Patent Bulletin, any person may give notice to the European Patent Office of opposition to that patent, in accordance with the Implementing Regulations. Notice of opposition shall not be deemed to have been filed until the opposition fee has been paid. (Art. 99(1) European Patent Convention).

**Description**Field of the Inventions

**[0001]** The inventions described below relate to instruments.

Background of the Inventions

**[0002]** The devices described below provide for improved heat transfer and sealing performance for our Starion® line of thermal cautery forceps and thermal ligating shears, and in instruments such as those disclosed in Treat, et al., Electrothermal Instrument For Sealing And Joining Or Cutting Tissue, U.S. Patent 6,626,901 (Sep. 30, 2003).

Summary

**[0003]** The thermal cautery and thermal ligating devices disclosed in U.S. Patent 6,626,901 are improved by the addition of a thermally conductive plate proximate to the resistive heating element used in those devices. Document EP 0170482 discloses a device as described in the preamble of claim 1.

Brief Description of The Drawings**[0004]**

Figures 1 and 2 illustrate laparoscopic thermal ligating shears designed to provide thermal ligation and division in numerous endoscopic procedures.

Figure 3 illustrates a forceps embodiment of a thermal cautery device.

Figure 4 illustrates the prior art construction of the distal tip of a thermal cautery device.

Figures 5 and 6 are cross sections of thermal cautery or thermal ligating devices with a thermally conductive plate interposed between the resistive heating element and the grasping face of the distal tip of the grasping arm of the device.

Figure 7 illustrates the effect of the thermal cautery or thermal ligating devices on a segment of body tissue.

Figures 8 and 9 illustrate embodiments of the heating element and thermally conductive plate.

Figure 10 illustrates a method of testing the thermal cautery or thermal ligating devices, said method is not an embodiment of the application.

Detailed Description of the Inventions

**[0005]** Figures 1 and 2 illustrate laparoscopic thermal ligating shears of the type marketed by Starion Instruments, Inc. with the improved heating assembly described below. These shears are designed to provide thermal ligation and division in numerous endoscopic procedures. The shears **1** comprises distal end **2** with remotely operable grasping assembly **3** and a proximal end **4** with a pistol grip actuator **5**. The distal end is adapted for insertion into the body of a patient through a laparoscopic access port. The grasping assembly comprises small grasping arms **6** and **7**, operably connected to the pistol grip actuator through the pivot section (hinge **8**) and actuator rod **9** running through the rigid tube **10**, such that operation of the actuator causes the grasping arms to open and close, thereby moving the respective grasping faces into apposition to each other. A resistive heating element (a heater wire or tube) **11** is fixed to the grasping face of the first grasping arm, running over the grasping face from the distal end to the proximal end of the grasping face. The first grasping arm is also covered with a resilient, non-stick, thermally insulative sleeve **12** to provide a resilient pad **13** on the grasping face under the heater wire, between the heater wire and the grasping face. A resilient, thermally insulative sleeve **14** covers the second grasping arm to provide a resilient pad on the grasping face of the second arm. A small thermally conductive but electrically insulative plate or sheet **15** is disposed over the first grasping face, extending laterally across the grasping face and longitudinally under the heating element.

**[0006]** Figure 2 provides a close up view of the grasping assembly **3**, showing the heater wire **11** thermally insulative sleeve **12** on the first grasping arm. Suitable materials for the sleeves and/or resilient pads include polytetrafluoroethylene (PTFE), KAPTON, mica, or silicone. Each sleeve serves to even out pressure applied to tissue and insulates the surfaces of grasping arms electrically and thermally. The thermally conductive but electrically insulative plate is visible between the heating element **11** and the resilient pad **12**. As shown in the figure, the plate may be curved and contoured to match the curvature of the grasping face, which in this case is arcuate in the distal-to-proximal aspect, and rounded laterally across the grasping face. This plate serves as a heat spreader to broaden the zone of heat application as illustrated below. The plate may be constructed of a high thermal conductivity metal such as aluminum, copper (and metals of lesser thermal conductivity such as titanium) and the like, a high thermal conductivity ceramics such as boron nitride or aluminum nitride or the like, or a plastic material incorporating a high thermal conductivity metal or ceramic. If the heat spreader is constructed of a material that is an electrical conductor, the heat spreader must be electrically isolated from the resistive heating element. Thus, if comprised of metal, the plate and resistive heating element must be electrically insu-

lated with a high temperature electrical insulator. This may be accomplished with an electrically insulative layer formed of an oxidized surface on the metal plate, such as can be done with metals such as titanium or aluminum. These materials may be covered by a thick layer of oxide of the metal, or by anodizing the metal plate, or with an electrically nonconductive coating on the metal plate or under the resistive wire.

**[0007]** Figure 3 illustrates thermal cautery forceps of the type marketed by Starion Instruments, Inc. with the addition of the improved heating assembly. The forceps **21** comprises grasping arms in the form of elongate forceps arms **22** and **23** with proximal ends **24** and **25** resiliently mounted to a pivot section (handle section **26**). The outer surfaces of forceps arms **22** and **23** are fitted with finger grips **27** and **28** to assist the operator in holding and activating the forceps. The opposing surfaces of the distal tips **29** and **30** of the forceps establish grasping faces which are aligned on each grasping arm so as to meet the grasping face of the other grasping arm upon closure of the grasping arms. Closure of the grasping arms is accomplished manually. The forceps arms may be formed of a suitable resilient material such as stainless steel, plastic, composites, etc. that have the desired combination of stiffness and resilience.

**[0008]** The distal tips include the various elements of the heating assembly. A resistive heating element (a heater wire) **34** is disposed on the grasping face of distal tip **30**, secured to the distal end of the grasping arm **23** and extending proximally over the grasping face of the grasping arm toward the proximal end of the grasping arm. The distal tip **30** is also covered with a resilient, non-stick, thermally insulative sleeve **35** to provide a resilient pad **36** on the grasping face under the heater wire, between the heater wire and the grasping face. The grasping face of the opposing distal tip **29** may also be covered by a resilient, non-stick, thermally insulative surface **37**, provided as a portion of sleeve **38** disposed over the distal tip **29**, in order to provide an anvil surface upon which the heating element acts during operation. The thermally conductive but electrically insulative plate **39** is disposed between the heating element **34** and the resilient pad **36**.

**[0009]** Additional elements of the forceps are also shown in Figure 3. The a finger-operated switch **40** preferably comprises a multi-directional post-in-tube design with a control button **41** and a contact switch disposed in opposition to one of the grasping arms which is operably connected with the power supply (not shown) and the heating element such power cannot be supplied to the heating element unless the contact switch is engaged when a user squeezes the grasping arms.

**[0010]** Figure 4 is a cross section illustrating a prior art construction of the distal tip of a thermal cautery device, while Figure 5 is a cross section of a thermal cautery device with a thermally conductive plate interposed between the resistive heating element and the grasping face of the distal tip of the grasping arm of the device. The components of the heating assembly components

shown in Figure 3 appear in both figures, with the exception of the plate **39**. As discussed in reference to Figure 3, the grasping face of the distal tip **30** is covered with the resilient pad **36** (which, as illustrated, is a portion of resilient sleeve **35** (the resilient sleeve may also establish a fluid-filled (air or liquid) gap over the outer surface of the distal tip, which helps prevent thermal damage to body tissue in the vicinity of the tissue to be cauterized and ligated)), and the resistive heating element **34** is disposed over the grasping face, over the resilient pad, so that it is located between the grasping faces. The distal tip **29** is covered by the resilient sleeve **38** to establish the resilient pad **37** on the grasping face of this distal tip.

**[0011]** In addition to the structure shown in Figure 4, Figure 5 shows the placement of the plate **39**, interposed between the heating element and the grasping face of the forceps arm **23**. The plate is arcuate, such that it bulges away from the grasping face of forceps arm **23** along its long distal-to-proximal centerline and bows away from the opposing grasping face toward the lateral sides of the device. A typical length of body tissue **42** is shown, held between the grasping faces. In Figure 4, the extent of heat affected zone in the body tissue is indicated by arrow **43**. The high heat generated by the heating wire, combined with light pressure exerted on the body tissue, results in division at line **44**. In comparison, as shown in Figure 5, the extent of heat affected zone in the body tissue, when the plate **39** is used, is indicated by arrow **45**. The wide lateral extent of heat affected zone results in a more secure seal of the tissue.

**[0012]** In Figure 6, which shows the grasping face of the distal tip **30** of the active grasping arm **23**, covered by the resilient pad **36**, the resistive heating element **34** disposed over the grasping face and the distal tip **29** of the opposing grasping arm with its resilient sleeve **38**, along with the plate **39** interposed between the heating element and the grasping face of the active grasping arm **23**. In this figure, the distal tip **30** of the active grasping arm **23** is cylindrical, with a substantially circular radial cross section. The resilient sleeve **35** surrounds and closely conforms to the cylindrical grasping arm, and the thermally conductive plate **39** is semi-cylindrical, and is disposed over the sleeve, between the sleeve and the resistive heating element. This embodiment provides for improved contact between the heat spreader and thicker tissues. The resultant divided tissue is shown in Figure 7, which shows the small area of division on either side of line **44**, and the wide lateral extent of thermally sealed tissue boundaries **46** and **47**.

**[0013]** Figures 8 and 9 illustrate the heating element and thermally conductive plate in additional detail. Figure 8 illustrates the laterally arcuate shape of the plate **39**, with a round wire heating element **34** overlying the plate. Figure 9 illustrates an oval cross-section wire heating element **51** physically and thermally intimate with or joined to the plate with channel beam **52**. The channel beam and plate of Figure 9 may be integrally formed, or formed of discrete components.

**[0014]** The plate greatly increases the amount of heat energy that can be delivered to the tissue prior to cutting the tissue. This increases the seal size (the amount of tissue that is sealed) and the integrity of the seal. With direct contact between the heating element and the thermally conductive plate, sufficient heat energy is conducted to the thermally conductive plate to heat the entire plan area of the tissue in contact with the thermally conductive plate to sealing temperatures. Sealing temperatures, which are generally between 60°C and 100°C, are achieved quickly because of the intimate contact between the heating element and the thermally conductive plate and the high thermal conductivity of the thermally conductive plate. Thermally isolating the thermally conductive plate from the forceps arms (a function provided by the sleeve) adds to the ability of the thermally conductive plate to quickly come up to temperature. The thermal resistance between the heating element and the thermally conductive plate results in temperatures that are always lower in the thermally conductive plate than in the heating element. This promotes tissue sealing in the thermally conductive plate area and tissue cutting in the heating element area. An added benefit of the thermally conductive plate is that it promotes even heating element temperatures due to increasing the effective longitudinal thermal conductivity of the heating element. Because the heating element and the thermally conductive plate are in intimate contact with very little thermal resistance between them the heating element longitudinal thermal conductivity is effectively improved because of the good longitudinal conductivity of the thermally conductive plate. This is very important when the heating element has uneven heat loads, as is usually the case. The high thermal conductivity of the thermally conductive plate allows it to transfer heat from one portion of the heating element to another colder portion of the heating element/thermally conductive plate assembly. This action pulls up the temperatures in the low spots and brings down the temperatures in the high spots. Bringing down the high temperatures is a benefit as very high temperatures, such as those in excess of 500°C, are undesirable. If temperatures below 300° C are maintained, non-stick components such as PTFE or ePTFE (Teflon®) coatings will survive for the life of the device. Temperatures in excess of 300°C will quickly destroy these components, and temperatures in excess of 600°C may melt an aluminum heat spreader.

**[0015]** Current Starion® device heating element plan areas are 0.022" (0,56 mm) wide by 0.75" (19,05 mm) long or 0.010" (0,254 mm) wide by 0.750" (19,05 mm) long. Using the thermally conductive plate with these existing heating elements, at power level of about 10 watts, results in heated plan areas which can be increased by 5 times or more over the prior device. Heat spreader dimensions of 0.065 (1,65 mm) to .100" (2,54 mm) wide have proven effective in testing.

**[0016]** Dimensions of the various components and the appropriate power levels for the thermal cautery devices

incorporating the heating element and heat spreader have been developed through testing on natural live tissue which closely approximates the sealing behavior of vascularized human body tissue. Specifically, live earthworms have been used in testing to develop the heat spreader design, thus making it quite convenient and inexpensive to test prototypes as necessary to optimize the geometry and material characteristics of the various components. As illustrated in Figure 9, live red worms **53** of 2 to 5 mm diameter (approximating the thickness of tissues of interest such as veins and arteries) were sealed and divided, at positions between the clitellum **54** and the mouth **55**. Prior to testing with the new devices, a number of earthworms in various conditions were tested with Starion® cautery forceps with well known effect on human and animal body tissue (having been tested with more expensive and burdensome animal testing and having been used commercially for some time) to determine their suitability. The earth worms proved to accurately model the response of live human tissue. To test the effectiveness of the thermal cautery devices, and to devise optimum component sizes and materials, live earth worms were sealed and divided with thermal cautery devices of various design. Earth worms of about 2 to 5 mm in diameter were used to model human vessels of 2 to 5 mm in diameter. The effectiveness of the thermal cautery devices was judged by the lateral extent of the sealed tissue, the width of the division (vaporized tissue at the line of division, and seal strength. The strength of the seal was judged by dividing a worm at two locations to form a worm segment with seals at both ends, and then pressurizing the worm segment to ascertain that certain predetermined internal pressure would overcome the seal. Successful sealing and division of the earth worm models translated directly into successful sealing and division of animal and human tissue. The use of the earth worm as a model for tissue in the testing of cautery devices thus provides an inexpensive and convenient method of bench testing cautery devices. The method may be used with cautery devices comprising the resistive heating element and heat spreader disclosed above, RF cautery devices, and various other means for thermally affecting body tissue.

**[0017]** In use, the thermal cautery device is manipulated to grasp body tissue, such as a blood vessel, a small section of fat, or other tissue as necessitated by the desired surgery. With the grasping arms on either side of the target tissue, surgeons gently close the grasping arms or forceps, as the case may be, to bring the grasping faces into apposition, with the target tissue held between the faces. While applying pressure to the tissue with the grasping faces, the surgeon energizes the device to provide a DC current to the heating wire. The heating wire itself heats up to temperatures above about 200°C, thus vaporizing the tissue immediately between the heating wire and the opposing grasping face (and a small lateral extent of tissue). Heat is applied for a period of time, in the range of 5 seconds to 20 seconds, thus al-

lowing heat from the heating element to conductively heat the heat spreader plate. Heat from the heat spreader plate, which typically reaches temperatures of 60°C to 100°C, is thereby applied to the tissue trapped between the heat spreader plate and the opposing grasping face, resulting in a thermal seal of the tissue with a width closely corresponding to the plan area of the plate (less the small vaporized section).

**[0018]** The improvements to the thermal cautery device have been described in relation to laparoscopic ligation devices and forceps devices, but they may be applied to open surgical forceps and clamps, catheter-based devices, and various other embodiments of thermal cautery and thermal ligation devices. Thus, while the preferred embodiments of the devices have been described in reference to the environment in which they were developed, they are merely illustrative of the principles of the inventions. Other embodiments and configurations may be devised without departing from the scope of the appended claims.

## Claims

### 1. A surgical device comprising:

opposable first and second grasping arms (6,7) extending from a pivot section, said first and second grasping arms being resiliently mounted to the pivot section to allow closure of the grasping arms, said first and second grasping arms each having a distal end with a grasping face, said grasping face on each grasping arm aligned to meet the grasping face of the other grasping arm upon closure of the grasping arms;

a resistive heating element (34) disposed upon the grasping face of the first grasping arm so that it lies between the grasping face of the first grasping arm and the grasping face of the second grasping arm upon closure of the grasping arms, said resistive heating element being operably connected to a source of electrical power; and

**characterized in that** said device comprises a thermally conductive plate (39) disposed between the resistive heating element (34) and the grasping face (35) of the first grasping arm.

2. The device of claim 1 wherein the plate is 1.65 mm (0,065 inches) to 2.54 mm (0,10 inches) wide.

3. The device of claim 1 further comprising an electrically insulative layer disposed between the resistive heating element and the plate.

4. The device of claim 3 wherein the electrically insulative layer comprises a coating on the thermally conductive plate.

5. The device of claim 3 wherein the thermally conductive plate comprises a metal and the electrically insulative layer comprises an oxide of the metal.

5 6. The device of claim 3 wherein the thermally conductive plate and electrically insulative layer comprise an anodized metal plate.

10 7. The device of claim 1 wherein the thermally conductive plate comprises a thermally conductivity ceramic.

15 8. The device of claim 1 wherein the thermally conductive plate comprises a plastic incorporating a high thermal conductivity metal or ceramic.

9. The device of claim 1 wherein the thermally conductive plate is arcuate relative to the transverse cross section of the grasping arms.

20 10. The device of claim 1, wherein the grasping face of the first grasping arm is substantially convex and the plate is substantially semi-cylindrical.

25 11. The device of claim 1, wherein the first grasping arm is substantially cylindrical and the plate is substantially semi-cylindrical.

30 12. The device of claim 1 further comprising:

a resilient surface on the grasping face of the first grasping arm, between the thermally conductive plate and the grasping face of the arm.

35 13. The device of claim 1 further comprising:

a thermally insulative surface on the grasping face of the first grasping arm, between the thermally conductive plate and the grasping face of the arm.

40

14. The device of claim 1 further comprising:

a sleeve covering the distal end of the first grasping arm, thereby forming a thermally insulative surface on the grasping face of the second grasping arm.

45

50 15. The device of claim 1 further comprising:

a resilient sleeve covering the distal end of the second grasping arm, thereby forming a resilient surface on the grasping face of the second grasping arm.

55

16. The device of claim 1 further comprising:

a resilient surface on the grasping face of each

of the first and second grasping arms.

17. The device of claim 1 further comprising:

a sleeve covering the distal end of the first grasping arm, thereby forming a surface on the grasping face of the first grasping arm, between the wire and the grasping face of the arm, and a resilient sleeve covering the distal end of the second grasping arm, thereby forming a resilient surface on the grasping face of the second grasping arm.

18. The device of claim 1 wherein the first and second grasping arms extend from a pivot section, said first and second grasping arms being resiliently mounted to the pivot section to allow closure of the grasping arms, whereby the first and second grasping arms and pivot section comprise a pair of tweezers.

19. The device of claim 1 wherein the first and second grasping arms extend from a pivot section, said first and second grasping arms being mounted to the pivot section to allow closure of the grasping arms, whereby the first and second grasping arms and pivot section comprise a forceps.

20. The device of claim 1 wherein the first and second grasping arms extend from a pivot section, and said first and second in grasping arms and pivot section are mounted on a rod adapted for insertion into the body through a laparoscopic access port, and said device further comprises a handle section operably connected to the pivot section for remotely operating the grasping faces.

### Patentansprüche

1. Chirurgische Einrichtung, umfassend:

einen gegenüberstellbaren ersten und zweiten Greifarm (6, 7), die sich von einem Schwenkteilabschnitt erstrecken, wobei der erste und zweite Greifarm federnd an dem Schwenkteilabschnitt befestigt sind, um ein Schließen der Greifarme zu ermöglichen, wobei der erste und zweite Greifarm jeweils ein distales Ende mit einer Greiffläche aufweisen, wobei die Greiffläche an jedem Greifarm ausgerichtet ist, um beim Schließen der Greifarme auf die Greiffläche des anderen Greifarms zu treffen;  
ein Widerstandsheizelement (34), das an der Greiffläche des ersten Greifarms angeordnet ist, sodass es beim Schließen der Greifarme zwischen der Greiffläche des ersten Greifarms und der Greiffläche des zweiten Greifarms liegt, wobei das Widerstandsheizelement wirksam mit

einer Quelle für elektrische Leistung verbunden ist; und

**dadurch gekennzeichnet, dass** die Einrichtung eine thermisch leitende Platte (39) umfasst, die zwischen dem Widerstandsheizelement (34) und der Greiffläche (35) des ersten Greifarms angeordnet ist.

2. Einrichtung nach Anspruch 1, wobei die Platte 1,65 mm (0,065 Inch) bis 2,54 mm (0,10 Inch) breit ist.

3. Einrichtung nach Anspruch 1, ferner umfassend eine elektrisch isolierende Schicht, die zwischen dem Widerstandsheizelement und der Platte angeordnet ist.

4. Einrichtung nach Anspruch 3, wobei die elektrisch isolierende Schicht eine Beschichtung an der thermisch leitenden Platte umfasst.

5. Einrichtung nach Anspruch 3, wobei die thermisch leitende Platte ein Metall umfasst und die elektrisch isolierende Schicht ein Oxid des Metalls umfasst.

6. Einrichtung nach Anspruch 3, wobei die thermisch leitende Platte und die elektrisch isolierende Schicht eine anodisierte Metallplatte umfassen.

7. Einrichtung nach Anspruch 1, wobei die thermisch leitende Platte eine Keramik mit thermischer Leitfähigkeit umfasst.

8. Einrichtung nach Anspruch 1, wobei die thermisch leitende Platte einen Kunststoff umfasst, der ein Metall oder eine Keramik mit hoher thermischer Leitfähigkeit umfasst.

9. Einrichtung nach Anspruch 1, wobei die thermisch leitende Platte relativ zum Querschnitt der Greifarme gekrümmt ist.

10. Einrichtung nach Anspruch 1, wobei die Greiffläche des ersten Greifarms im Wesentlichen konvex ist und die Platte im Wesentlichen halbzyylinderförmig ist.

11. Einrichtung nach Anspruch 1, wobei der erste Greifarm im Wesentlichen zylinderförmig ist und die Platte im Wesentlichen halbzyylinderförmig ist.

12. Einrichtung nach Anspruch 1, ferner umfassend:

eine elastische Oberfläche an der Greiffläche

- des ersten Greifarms zwischen der thermisch leitenden Platte und der Greiffläche des Arms.
13. Einrichtung nach Anspruch 1, ferner umfassend:
- 5 eine thermisch isolierende Oberfläche an der Greiffläche des ersten Greifarms zwischen der thermisch leitenden Platte und der Greiffläche des Arms.
14. Einrichtung nach Anspruch 1, ferner umfassend:
- 10 eine Hülse, die das distale Ende des ersten Greifarms bedeckt, wodurch eine thermisch isolierende Oberfläche an der Greiffläche des zweiten Greifarms ausgebildet wird.
15. Einrichtung nach Anspruch 1, ferner umfassend:
- 15 eine elastische Hülse, die das distale Ende des zweiten Greifarms bedeckt, wodurch eine elastische Oberfläche an der Greiffläche des zweiten Greifarms ausgebildet wird.
16. Einrichtung nach Anspruch 1, ferner umfassend:
- 25 eine elastische Oberfläche an der Greiffläche des ersten und zweiten Greifarms.
17. Einrichtung nach Anspruch 1, ferner umfassend:
- 30 eine Hülse, die das distale Ende des ersten Greifarms bedeckt, wodurch eine Oberfläche an der Greiffläche des ersten Greifarms zwischen dem Draht und der Greiffläche des Arms ausgebildet wird, und
- 35 eine elastische Hülse, die das distale Ende des zweiten Greifarms bedeckt, wodurch eine elastische Oberfläche an der Greiffläche des zweiten Greifarms ausgebildet wird.
- 40
18. Einrichtung nach Anspruch 1, wobei sich der erste und zweite Greifarm von einem Schwenkteilabschnitt erstrecken, wobei der erste und zweite Greifarm federnd an dem Schwenkteilabschnitt befestigt sind, um ein Schließen der Greifarme zu ermöglichen, wodurch der erste und zweite Greifarm und der Schwenkteilabschnitt eine Pinzette umfassen.
- 45
19. Einrichtung nach Anspruch 1, wobei sich der erste und zweite Greifarm von einem Schwenkteilabschnitt erstrecken, wobei der erste und zweite Greifarm an dem Schwenkteilabschnitt befestigt sind, um ein Schließen der Greifarme zu ermöglichen, wodurch der erste und zweite Greifarm und der Schwenkteilabschnitt eine Zange umfassen.
- 55

20. Einrichtung nach Anspruch 1, wobei sich der erste und zweite Greifarm von einem Schwenkteilabschnitt erstrecken und der erste und zweite Greifarm und der Schwenkteilabschnitt an einem Stab befestigt sind, der für ein Einführen in den Körper durch eine laparoskopische Zugangsöffnung geeignet ist, und wobei die Einrichtung ferner einen Griffteilabschnitt umfasst, der wirksam mit dem Schwenkteilabschnitt verbunden ist, um die Greifflächen aus der Ferne zu betätigen.

## Revendications

1. Dispositif chirurgical comprenant :
- des premier et second bras de saisie opposables (67) s'étendant à partir d'une section pivot, les premier et second bras de saisie étant montés de façon résiliente à la section pivot afin de permettre la fermeture des bras de saisie, les premier et second bras de saisie présentant chacun une extrémité distale et une face de saisie, la face de saisie sur chaque bras de saisie étant alignée de telle sorte qu'elle rejoint la face de saisie de l'autre bras de saisie lors de la fermeture des bras de saisie,
- un élément de chauffage résistif (34) disposé sur la face de saisie du premier bras de saisie de telle sorte qu'il repose entre la face de saisie du premier bras de saisie et la face de saisie du second bras de saisie lors de la fermeture des bras de saisie, l'élément de chauffage résistif étant connecté de manière opérationnelle à une source de courant électrique, et
- caractérisé en ce que** le dispositif comprend une plaque conductrice thermique (39) disposée entre l'élément de chauffage résistif (34) et la face de saisie (35) du premier bras de saisie.
2. Dispositif selon la revendication 1, dans lequel la plaque présente une largeur comprise entre 1,65 mm (0,06 pouces) et 2,54 mm (0,10 pouces).
3. Dispositif selon la revendication 1, comprenant en outre une couche électriquement isolante disposée entre l'élément de chauffage résistif et la plaque.
- 50 4. Dispositif selon la revendication 3, dans lequel la couche électriquement isolante comprend un revêtement sur la plaque thermiquement conductrice.
5. Dispositif selon la revendication 3, dans lequel la plaque thermiquement conductrice comprend un métal et la couche électriquement isolante comprend un oxyde du métal.

6. Dispositif selon la revendication 3, dans lequel la plaque thermiquement conductrice et la couche électriquement isolante comprennent une plaque en métal anodisé.
7. Dispositif selon la revendication 1, dans lequel la plaque thermiquement conductrice comprend une céramique thermiquement conductrice.
8. Dispositif selon la revendication 1, dans lequel la plaque thermiquement conductrice comprend un plastique incorporant un métal ou une céramique présentant un degré élevé de conductivité thermique.
9. Dispositif selon la revendication 1, dans lequel la plaque thermiquement conductrice est arquée par rapport à la section transversale des bras de saisie.
10. Dispositif selon la revendication 1, dans lequel la face de saisie du premier bras de saisie est sensiblement convexe et la plaque est sensiblement semi-cylindrique.
11. Dispositif selon la revendication 1, dans lequel le premier bras de saisie est sensiblement cylindrique et la plaque est sensiblement semi-cylindrique.
12. Dispositif selon la revendication 1, comprenant en outre :
- une surface résiliente sur la face de saisie du premier bras de saisie, entre la plaque thermiquement conductrice et la face de saisie du bras.
13. Dispositif selon la revendication 1, comprenant en outre :
- une surface thermiquement isolante sur la face de saisie du premier bras de saisie, entre la plaque thermiquement conductrice et la face de saisie du bras.
14. Dispositif selon la revendication 1, comprenant en outre :
- un manchon recouvrant l'extrémité distale du premier bras de saisie, formant ainsi une surface thermiquement isolante sur la face de saisie du second bras de saisie.
15. Dispositif selon la revendication 1, comprenant en outre :
- un manchon résilient recouvrant l'extrémité distale du second bras de saisie, formant ainsi une surface résiliente sur la face de saisie du second bras de saisie.
16. Dispositif selon la revendication 1, comprenant en outre :
- une surface résiliente sur la face de saisie de chacun des premier et second bras de saisie.
17. Dispositif selon la revendication 1, comprenant en outre :
- un manchon recouvrant l'extrémité distale du premier bras de saisie, formant ainsi une surface sur la face de saisie du premier bras de saisie, entre le fil conducteur et la face de saisie du bras, et
- un manchon résilient recouvrant l'extrémité distale du second bras de saisie, formant ainsi une surface résiliente sur la face de saisie du second bras de saisie.
18. Dispositif selon la revendication 1, dans lequel les premier et second bras de saisie s'étendent à partir d'une section pivot, les premier et second bras de saisie étant montés de façon résiliente sur la section pivot afin de permettre la fermeture des bras de saisie, et dans lequel les premier et second bras de saisie et la section pivot comprennent une paire de brucelles.
19. Dispositif selon la revendication 1, dans lequel les premier et second bras de saisie s'étendent à partir d'une section pivot, les premier et second bras de saisie étant montés sur la section pivot afin de permettre la fermeture des bras de saisie, et dans lequel les premier et second bras de saisie et la section pivot comprennent des pinces.
20. Dispositif selon la revendication 1, dans lequel les premier et second bras de saisie s'étendent à partir d'une section pivot, les premier et second bras de saisie et la section pivot étant montés sur une tige adaptée à l'insertion dans le corps par l'intermédiaire d'un port d'accès laparoscopique, et le dispositif comprenant également une section poignée connectée de façon opérationnelle à la section pivot afin de contrôler à distance les faces de saisie.

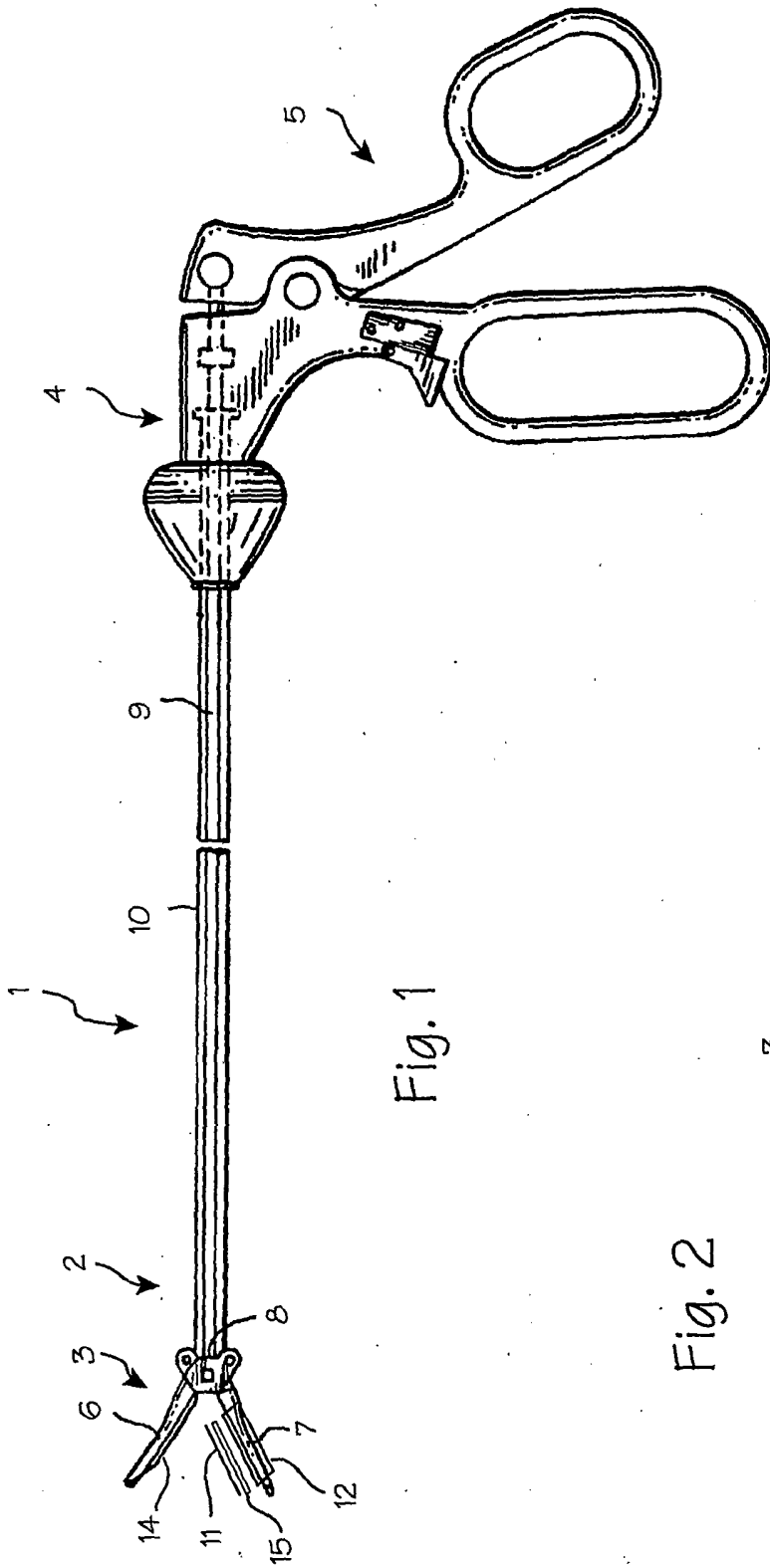
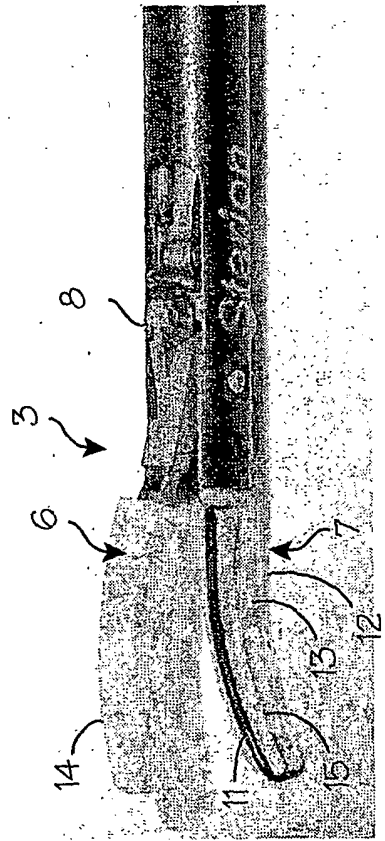

Fig. 1

Fig. 2







**REFERENCES CITED IN THE DESCRIPTION**

*This list of references cited by the applicant is for the reader's convenience only. It does not form part of the European patent document. Even though great care has been taken in compiling the references, errors or omissions cannot be excluded and the EPO disclaims all liability in this regard.*

**Patent documents cited in the description**

- US 6626901 B [0002] [0003]
- EP 0170482 A [0003]

专利名称(译)	具有改进的加热曲线的热烧灼装置和测试热烧灼装置的方法		
公开(公告)号	<a href="#">EP1689307A4</a>	公开(公告)日	2008-05-28
申请号	EP2004819100	申请日	2004-11-10
[标]申请(专利权)人(译)	STARION INSTR		
申请(专利权)人(译)	STARION仪器公司		
当前申请(专利权)人(译)	STARION仪器公司		
[标]发明人	MCGAFFIGAN THOMAS H ECHEVERRY JAN M BOUDIN DONIELLE CARLOTTO PETER LE HUY		
发明人	MCGAFFIGAN, THOMAS, H. ECHEVERRY, JAN, M. BOUDIN, DONIELLE CARLOTTO, PETER LE, HUY		
IPC分类号	A61B18/18 A61B18/00 A61B18/08 A61B18/14		
CPC分类号	A61B18/085 A61B2018/00095		
代理机构(译)	VAN WALSTIJN , BARTHOLOMEUS G. G.		
优先权	10/713490 2003-11-14 US 10/713341 2003-11-14 US		
其他公开文献	EP1689307B1 EP1689307A1		
外部链接	<a href="#">Espacenet</a>		

摘要(译)

热烧灼和热结扎装置 ( 1 ) 通过在这些装置中使用的电阻加热元件 ( 11 ) 附近添加导热板而得到改善。

