



- (51) International Patent Classification:  
A61B 18/26 (2006.01) A61B 17/221 (2006.01)  
A61B 17/22 (2006.01) A61B 90/00 (2016.01)
- (21) International Application Number:  
PCT/US2017/029914
- (22) International Filing Date:  
27 April 2017 (27.04.2017)
- (25) Filing Language: English
- (26) Publication Language: English
- (30) Priority Data:  
15/141,458 28 April 2016 (28.04.2016) US
- (71) Applicant: **CALCULA TECHNOLOGIES, INC.**  
[US/US]; 959 Peralta Ave., San Francisco, CA 94110 (US).
- (72) Inventors: **BONNEAU, Raymond, Arthur**; 59 Molimo Drive, San Francisco, CA 94127 (US). **GAL, David**; 1155 Hayes Street, #2, San Francisco, CA 94127 (US).
- (74) Agent: **BRUESS, Steven, C.**; Merchant & Gould P.C., P.O. Box 2903, Minneapolis, MN 55402-0903 (US).
- (81) Designated States (unless otherwise indicated, for every kind of national protection available): AE, AG, AL, AM, AO, AT, AU, AZ, BA, BB, BG, BH, BN, BR, BW, BY, BZ, CA, CH, CL, CN, CO, CR, CU, CZ, DE, DJ, DK, DM, DO, DZ, EC, EE, EG, ES, FI, GB, GD, GE, GH, GM, GT, HN, HR, HU, ID, IL, IN, IR, IS, JP, KE, KG, KH, KN, KP, KR, KW, KZ, LA, LC, LK, LR, LS, LU, LY, MA, MD, ME, MG, MK, MN, MW, MX, MY, MZ, NA, NG, NI, NO, NZ, OM, PA, PE, PG, PH, PL, PT, QA, RO, RS, RU, RW, SA, SC, SD, SE, SG, SK, SL, SM, ST, SV, SY, TH, TJ, TM, TN, TR, TT, TZ, UA, UG, US, UZ, VC, VN, ZA, ZM, ZW.

(54) Title: BASKET AND EVERTING BALLOON WITH SIMPLIFIED DESIGN AND CONTROL

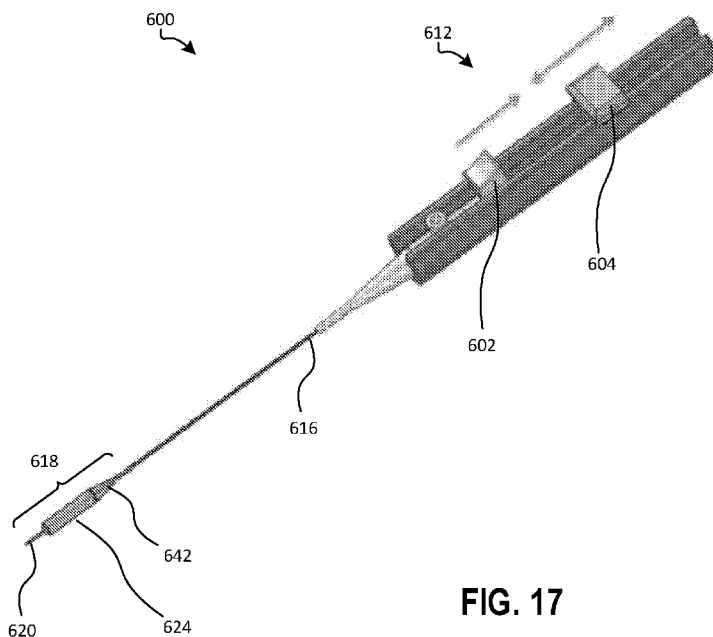

FIG. 17

(57) Abstract: Disclosed systems, methods, and devices may include a system for removing a kidney stone from a ureter. The system may have an inner shaft extending coaxially within an outer shaft, a stone retention member shaft having a stone retention member and extending coaxially within the inner shaft, a wall protection member coupled to the outer shaft and the inner shaft, and a handle coupled with proximal ends of the outer shaft, the inner shaft, and the stone retention member shaft. The handle may include an eversion mechanism coupled to the inner shaft and configured to actuate the inner shaft, thereby everting the wall protection member to form a pocket adapted to receive a kidney stone. The system may also include a retention member mechanism coupled to the stone retention member shaft and configured to actuate the stone retention member shaft.



**(84) Designated States** (*unless otherwise indicated, for every kind of regional protection available*): ARIPO (BW, GH, GM, KE, LR, LS, MW, MZ, NA, RW, SD, SL, ST, SZ, TZ, UG, ZM, ZW), Eurasian (AM, AZ, BY, KG, KZ, RU, TJ, TM), European (AL, AT, BE, BG, CH, CY, CZ, DE, DK, EE, ES, FI, FR, GB, GR, HR, HU, IE, IS, IT, LT, LU, LV, MC, MK, MT, NL, NO, PL, PT, RO, RS, SE, SI, SK, SM, TR), OAPI (BF, BJ, CF, CG, CI, CM, GA, GN, GQ, GW, KM, ML, MR, NE, SN, TD, TG).

**Published:**

— *with international search report (Art. 21(3))*

## BASKET AND EVERTING BALLOON WITH SIMPLIFIED DESIGN AND CONTROL

This application is being filed on 27 April 2017, as a PCT International  
5 patent application, and claims priority to U.S. Patent Application No. 15/141,458,  
filed April 28, 2016, the disclosure of which is hereby incorporated by reference  
herein in its entirety.

### CROSS-REFERENCE TO RELATED APPLICATIONS

[0001] Also, the priority application (15/141,458) is a a continuation-in-part of  
10 U.S. Patent Application No. 14/977,087, filed December 21, 2015, entitled “Devices  
for Removing Kidney Stones,” which is a continuation of U.S. Patent Application  
No. 14/205,026, filed March 11, 2014 and issued as U.S. Patent No. 9,232,956,  
which claims priority to U.S. Provisional Application Nos. 61/897,769, filed  
October 30, 2013, and 61/860,140, filed July 30, 2013 and 61/812,511, filed April  
15 16, 2013. This application also claims priority to U.S. Provisional Application No.  
62/154,586, filed April 29, 2015, entitled “Inverting Balloon with Simplified Design  
and Control.” The entireties of each application above are herein incorporated by  
reference for any and all purposes.

[0002] This application is related to co-pending U.S. Patent Application Nos.  
20 14/605,814, filed January 25, 2015, entitled “Method for Removing Kidney Stones”  
and 14/205,217, filed March 11, 2014, entitled “Method for Removing Kidney  
Stones.” The entireties of each co-pending application above are herein  
incorporated by reference for any and all purposes.

### TECHNICAL FIELD

25 [0003] The present disclosure relates to medical devices and methods. More  
specifically, the disclosure relates to devices and methods for removing kidney  
stones.

### BACKGROUND

[0004] Kidney stones (known as ureteral calculi in medical terminology) are a  
30 significant burden on society and health care systems. Kidney stones form in the  
body when the amount of various minerals in urine exceeds an amount that can be

eliminated (the metastable limit), and the excess minerals form a precipitate. Most kidney stones are comprised of calcium and oxalate, though uric acid, struvite, cysteine, and other stone compositions are also common.

5 [0005] Kidney stones typically form in the parts of the kidney known as the renal pelvis or calyces and can stay there for years. When a stone dislodges, it makes its way down the upper urinary tract towards the bladder. Stones often get stuck en route to the bladder in the ureter. One reason for this is that mechanical rubbing of the sharp stone on the ureter's mucosal lining causes an inflammatory response and swelling (or "edema"), which inhibits the stone's ability to pass. This obstruction  
10 impedes the passage of urine from the kidney to the bladder, which results in increased internal pressure in the kidney. This pressure rise causes nerve fibers in the kidney to stretch, which in turn results in the excruciating pain well known to accompany stones. Clinically, this pain is known as "renal colic" and comes in unexpected bursts lasting 2–18 hours, until the internal pressure of the kidney is  
15 reduced. As long as the stone remains in the urinary tract, a patient will be at risk for renal colic. Female patients describe stones as worse than natural childbirth, while male patients describe it as the most excruciating experience of their lives.

[0006] Pain relief from kidney stones typically occurs instantly after stone passage or removal. Waiting for kidney stones to pass, however, can be a long and painful  
20 process. Currently, three general types of kidney stone removal methods are used, all of which have at least some shortcomings.

[0007] Extracorporeal Shockwave Lithotripsy (ESWL) is a procedure in which shockwaves are transmitted through the body in the direction of a kidney stone, in an attempt to fragment the stone into smaller pieces. For the ESWL procedure, a  
25 patient lies on a special bed (which costs approximately \$750,000), is given sedation anesthesia, and is bombarded with 45–90 shocks per minute over the course of 45 minutes to one hour. The shocks are so intense that they must be synchronized with the patient's heartbeat so as not to cause cardiac arrhythmias. ESWL outcomes are mixed: 33% of patients have a successful outcome and pass "sand," 33% of patients  
30 pass several smaller stones with excruciating pain, and 33% of patients are unaffected by the treatment. Recent studies have raised concerns about potential long-term complications of ESWL, including hypertension and diabetes. Due to the uncertain outcomes, required sedation anesthesia, and potentially hazardous

mechanism of the treatment, ESWL is indicated only for patients with 8–13 mm stones located in the kidney itself. Generally, stones of this size and location are asymptomatic.

5 [0008] Ureteroscopy (URS) is a procedure in which a urologist inserts an endoscope up the urethra, into the bladder, and up the ureter to the site of the stone. Using a laser, the urologist fragments the stone into smaller pieces and retracts the fragments with a retention member. The procedure requires general anesthesia, high skill level from the urologist, and anywhere from 20 minutes to one hour. The endoscope, laser source, and fluoroscopy require an investment of approximately  
10 \$225,000 in capital equipment alone. The ureteroscopes themselves cost approximately \$15,000 and can typically be used in only about 15 procedures before needing to be replaced or repaired. The typical amount of manipulation of the ureteroscope within the ureter during the procedure, as well as the overall time spent in the ureter, can induce ureteral stricture (blockages of the ureter caused by a  
15 process similar to scarring). The procedure outcome is generally highly effective, but due to the risk of complications and required general anesthesia, URS is generally recommended only for stones that are 8–15 mm in size.

[0009] Percutaneous Nephrectomy Lithotripsy (PCNL) is a surgical procedure in which a tube is inserted through the back into the kidney. Stones are removed  
20 through the tube, using lasers, graspers, and aspiration. Though PCNL is highly effective, its invasiveness renders it applicable only to stones larger than 15 mm.

[0010] As described above, the currently available procedures for kidney stone removal are generally quite invasive and require (1) at least sedation anesthesia and in many cases general anesthesia, (2) expansive, specialized capital equipment, and  
25 (3) experienced and knowledgeable urologists to perform the procedures.

Furthermore, most small kidney stones ultimately pass without any intervention.

Therefore, despite the incredible, debilitating pain involved in passing kidney stones naturally, that is typically the method of choice, since kidney stone removal methods have such significant drawbacks.

30 [0011] Thus, it would be advantageous to have additional treatment options for kidney stone removal. Ideally, these options would be less invasive, less expensive, less prone to side effects, and/or require less physician expertise to perform. It would also be ideal if some of the additional treatment options could be used, or

adapted for use, in other parts of the body to remove other obstructions. At least some of these objectives will be met by the embodiments described herein.

#### SUMMARY

5 [0012] Technologies are generally described that include systems, methods, and devices.

[0013] An example system may include an inner shaft extending coaxially within an outer shaft. The system may further include a stone retention member shaft having a stone retention member and extending coaxially within the inner shaft. The system may further include a wall protection member coupled to the outer shaft and the inner shaft. The system may further include a handle coupled with proximal 10 ends of the outer shaft, the inner shaft, and the stone retention member shaft. The handle may include an eversion mechanism coupled to the inner shaft and configured to actuate the inner shaft, thereby everting the wall protection member to form a pocket adapted to receive a kidney stone. The handle may further include a retention member mechanism coupled to the stone retention member shaft and 15 configured to actuate the stone retention member shaft.

[0014] In another example, a system may include an inner shaft extending coaxially within an outer shaft. The system may also include a stone retention member shaft having a stone retention member and extending coaxially within the 20 inner shaft, the stone retention member configured to capture a kidney stone. The system may further include a wall protection member coupled to the outer shaft and the inner shaft. The system may further include a handle coupled with proximal ends of the outer shaft, the inner shaft, and the stone retention member shaft, the handle comprising a retention member mechanism coupled to the stone retention 25 member shaft and configured to move the stone retention member shaft. The wall protection member may be configured to evert and form a pocket responsive to axial force of proximal movement of the stone retention member having a captured kidney stone.

[0015] In another example, a method may include advancing a distal end of an 30 elongate, flexible kidney stone removal device into the ureter to a location near the kidney stone. The method may further include advancing, using a retention member mechanism at a handle of the device, a shaft of an expandable stone retention member through an inner shaft of the device to expose an expandable, stone

retention portion of the stone retention member out of a distal end of the inner shaft. The method may further include trapping the kidney stone in the stone retention portion of the stone retention member. The method may further include everting a portion of the wall protection member to form a pocket. The method may further  
5 include retracting, using the retention member mechanism, the retention portion having the trapped kidney stone into the pocket. The method may further include removing the kidney stone removal device from the ureter while the stone retention member and the kidney stone are at least partially within the pocket.

10

### BRIEF DESCRIPTION OF THE DRAWINGS

**[0016]** Certain preferred embodiments and modifications thereof will become apparent to those skilled in the art from the detailed description below having reference to the figures that follow.

**[0017]** FIGS. 1A and 1B are perspective and side views, respectively, of a system  
15 for removing kidney stones from ureters or other obstructions from other body lumens, according to one embodiment;

**[0018]** FIGS. 2A and 2B are perspective views of a distal portion of the system of FIGS. 1A and 1B, illustrating a portion of a method for retaining a kidney stone in the system, according to one embodiment;

**[0019]** FIGS. 3A and 3B are side cross-section and end-on cross-section views,  
20 respectively, of a kidney stone removal system similar to the system of FIGS. 1A, 1B, 2A and 2B;

**[0020]** FIGS. 4A–4E are schematic side views of a ureter and kidney stone,  
25 illustrating a method for removing a stone from a ureter using a system such as that described in FIGS. 1A, 1B, 2A, 2B, 3A and 3B, according to one embodiment;

**[0021]** FIGS. 5A–5F are schematic side views of a ureter and kidney stone,  
illustrating a method for removing a stone from a ureter using a system such as that described in FIGS. 1A, 1B, 2A, 2B, 3A and 3B, according to an alternative embodiment;

**[0022]** FIGS. 6A and 6B are perspective views of a distal portion of a kidney  
30 stone removal system having an expandable basket and a funnel member, according to an alternative embodiment;

[0023] FIGS. 7A and 7B are perspective and close-up views, respectively, of an expandable grasper that may be a part of a kidney stone removal system, according to an alternative embodiment;

5 [0024] FIGS. 8A and 8B are perspective views of a distal portion of a kidney stone removal system (FIG. 7B shown within a ureter with a kidney stone) having an expandable grasper and a compliant membrane, according to an alternative embodiment;

10 [0025] FIG. 9 is a side view of a distal portion of a kidney stone removal system having an expandable grasper and an inflatable balloon, according to an alternative embodiment;

[0026] FIG. 10 is a perspective view of a distal portion of a kidney stone removal system having an expandable grasper, a compliant membrane and a camera, according to an alternative embodiment;

15 [0027] FIGS. 11A and 11B are side views of a distal portion of a kidney stone removal system having an expandable mesh basket and an inflatable balloon, according to an alternative embodiment;

[0028] FIG. 12 is a perspective view of a distal portion of a kidney stone removal system having an expandable mesh basket and a webbing between the mesh, according to an alternative embodiment;

20 [0029] FIGS. 13A and 13B are perspective and side views, respectively, of a distal portion of a kidney stone removal system having a balloon, according to one embodiment;

[0030] FIG. 14A is a perspective view of a distal portion of a kidney stone removal system having a balloon, according to an alternative embodiment; and

25 [0031] FIG. 14B is a perspective view of a distal portion of a kidney stone removal system having a balloon, according to another alternative embodiment.

[0032] FIGS. 15A and 15B are side cross-section and end-on cross-section views, respectively, of a kidney stone removal system according to some embodiments.

30 [0033] FIGS. 16A and 16B are side cross-section and end-on cross-section views, respectively, of a kidney stone removal system according to some embodiments.

[0034] FIG. 17 illustrates an example kidney stone removal system according to some embodiments.

[0035] FIGS. 18A–18D illustrate an example movement of shafts of a kidney stone removal system according to some embodiments.

5 [0036] FIGS. 19A–19E illustrate an example movement of shafts of a kidney stone removal system according to some embodiments.

#### DETAILED DESCRIPTION

[0037] This application describes a number of embodiments of devices, systems  
10 and methods for removing obstructions from body lumens and passageways. Although the embodiments are described primarily for use in removing kidney stones from the urinary tract, at least some of the embodiments may also be used, or may be adapted for use, in other parts of the body to remove other obstructions. Therefore, the following description should not be interpreted as limiting the scope  
15 of this application to kidney stone removal, since any embodiment described may be used or adapted for other uses. The terms “kidney stone,” “stone” and “obstruction” may be used interchangeably herein. Additionally, although many of the descriptions below focus on removal of a kidney stone from the ureter, other parts of the body and/or other obstructions may be addressed in other embodiments. The  
20 terms “lumen” and “vessel,” for example, may be used generally and interchangeably to refer to areas in which obstructions may be located.

[0038] Generally, this application describes devices, systems and methods for removing kidney stones from ureters (or other obstructions from other body lumens). In some embodiments, kidney stone removal may be performed without fragmenting  
25 the stones before removal. Alternatively, some embodiments may be used to remove fragmented stones. The various embodiments of devices, systems and methods described herein typically include one or more elongate, flexible shafts, arranged coaxially relative to one another, one or more end effectors at the distal end of the shaft(s) for removing the kidney stone, and a handle at the proximal end of the  
30 shaft(s) for manipulating the shaft(s) and end effector(s). The inventors of the devices, systems and methods described herein have found that it may be advantageous to include, in each embodiment, at least two of the following three

aspects. It may be most advantageous to include all three aspects in a given embodiment, and some embodiments do include all three, but that is not a requirement.

5 **[0039]** Obstruction retention. This refers to a mechanism for retaining or otherwise applying a force to the kidney stone or other obstruction for the purpose of retaining, manipulating and eventually removing the obstruction. Several examples of obstruction retention members described below include, but are not limited to, expandable graspers, expandable baskets and expandable balloons with cavities for trapping obstructions.

10 **[0040]** Ureter wall protection. This refers to a mechanism for protecting the ureteral wall (or wall of another lumen or vessel) from trauma caused by the stone or other obstruction rubbing against the wall during removal. In some but not all embodiments, ureter/vessel wall protection may involve ureteral/vessel dilation. Such embodiments may include a mechanism to provide dilation around the  
15 obstruction to reduce friction and eliminate trauma to the lumen wall caused by contact of the obstruction surface with the lumen wall. Generally, embodiments may involve any soft, compliant or low-friction material that may be positioned between the stone and the ureter wall. Several examples of ureter wall protection members described below include, but are not limited to, expandable balloons,  
20 shafts, and hydrodilation members that emit fluid to expand the ureter/vessel/lumen.

**[0041]** Obstruction detection and/or identification. This refers to a mechanism to identify the obstruction location and ensure retention and/or dilation is applied in the proper location relative to the obstruction. Detection may also be used to ensure  
25 removal of the stone and for general navigational purposes in the lumen or other orifice. One example of an obstruction detection member described below includes, but is not limited to, a fiber optic camera incorporated into an obstruction removal device. As another example, fluoroscopy may be used to visualize one or more aspects of a procedure, including device navigation.

**[0042]** Many of the embodiments of devices, systems and methods described  
30 below may include one mechanism from each of the three categories above—obstruction retention, ureter wall protection and obstruction detection. This combination may be advantageous in providing for effective kidney stone removal with minimal trauma to the ureter. In many embodiments, it will be possible to

combine different mechanisms from one category with different mechanisms from another category to form an alternative embodiment. For clarity, the descriptions below will not always repeat details about various mechanisms from each category for each embodiment. For example, if a fiber optic camera is described in relation to one embodiment as a stone detection mechanism, that same camera need not be described again in detail for use with another embodiment. Mechanisms from each of the three categories may be combined with each other in any suitable way to form various alternative embodiments.

**[0043]** Referring to FIGS. 1A–1B, in one embodiment, a kidney stone removal system 10 may include a handle 12, a handle extension 14, an outer shaft 16 and an end effector 18. In one embodiment, end effector 18 may include an expandable stone retention member 20 (also referred to in this embodiment as “basket 20”), a visualization device 22 (also referred to in this embodiment as “camera 22”), and a wall protection member 24 (also referred to in this embodiment as “inflatable balloon 24”). Handle extension 14, as mentioned above, is simply a sliding portion of handle 12, which slides out of and back into the distal end of handle 12. It is an optional feature. In this embodiment, handle extension 14 is coupled with a balloon fill port 26, an irrigation port 28 and a shaft slider 30. Handle 12 may include a retention member slider 32 and may be coupled with a camera proximal portion 34, which may include an imaging sensor (and electronics) and/or a light source in some embodiments. Many of these features are described in further detail below.

**[0044]** In various embodiments, end effector 18 may include a number of variations, such as different components, differently sized components, and the like. For ease of description, end effector 18 is referred to here as a distal portion of system 10, which includes multiple different kidney stone removal components. Alternatively, the term “end effector” may be used elsewhere herein to refer to one component at or near the distal end of system 10. In the embodiment illustrated in FIGS. 1A and 1B, end effector 18 includes stone retention member 20, which includes a retention member shaft (not visible in FIGS. 1A and 1B) and an expandable, stone retention portion extending distally from a distal end of the retention member shaft. In this embodiment, the stone retention portion is an expandable basket. Again, the terms “stone retention member 20” and “basket 20” may be used interchangeably herein, although the stone retention member may

comprise a one-piece or attached retention member shaft and expandable stone retention portion. In alternative embodiments, the stone retention portion of stone retention member 20 may be something other than an expandable basket, such as an expandable cup, tongs or the like.

- 5 [0045] Basket 20 may be made of Nitinol, spring stainless steel, shape memory polymer, or any other suitable shape-memory material. Basket 20 may be an extension of (or alternatively attached to) a distal end of the retention member shaft, which may be disposed within an inner shaft (not visible in FIGS. 1A and 1B). The inner shaft, in turn, is located within outer shaft 16. The various relationships of the shafts, according to at least one embodiment, are described in further detail below, 10 in relation to FIGS. 3A and 3B. Generally, basket 20 is housed within the inner shaft during advancement of shaft 16 into and through the ureter. Basket 20 is then advanced distally out of the inner shaft to be released from constraint. Upon release from constraint, basket 20 expands and may then be used to trap a kidney stone.
- 15 Basket 20 may include any suitable number of struts, such as but not limited to the four struts illustrated in FIGS. 1A and 1B.

[0046] In some embodiments, end effector 18 may also include visualization device 22 (or “camera 22”) for detection and visualization of kidney stones. Visualization device 22 refers generally to the entire device used in system 10 for 20 visualization and not just the distal tip of device 22 that is illustrated in FIGS. 1A and 1B. For example, camera 22 typically extends from a distal end, located at or near a distal end of the inner shaft, through the inner shaft, to camera proximal portion 34, which is attached to handle 12. Camera 22 may be any suitable small camera, such as but not limited to a fiber optic camera, a CCD (charge-coupled 25 device) image sensor or a CMOS (complementary metal–oxide–semiconductor) camera. Camera proximal portion 34 may be attached via a cable with one or more conductors to an image-processing console (not shown), which displays an image on a viewing screen. Alternatively, camera proximal portion 34 may contain an eyepiece, through which an image may be observed and/or magnified using other 30 techniques common in the art of endoscopy. The distal, viewing end of camera 22 is located in end effector 18, so that it may be used to visualize a kidney stone located in the ureter in front of system 10. In some embodiments, camera 22 is located coaxially within the retention member shaft (again, not shown in FIGS. 1A and 1B

but illustrated later), with its distal end positioned at or near a distal end of the inner shaft and/or the retention member shaft. The retention member shaft extends distally to form basket 20, and the distal tip of camera 22, in these embodiments, generally faces directly into the expandable portion of basket 20.

- 5 [0047] In some embodiments, the distal end of camera 22 may be fixed in place, relative to the distal tip of the inner shaft. Camera 22 extends from its distal end, proximally through the retention member shaft to camera proximal portion 34, which is coupled with handle 12. In various embodiments of system 10, any suitable camera 22 currently available or as yet to be invented may be used.
- 10 Furthermore, although visualization device 22 is referred to herein as a “camera,” any other suitable visualization device may be used in alternative embodiments. In some embodiments, system 10 may include camera 22, while in other embodiments, system 10 may be provided without camera 22, and any of a number of available cameras may be added to system 10.
- 15 [0048] Finally, end effector 18 may also include wall protection member 24, also referred to as inflatable balloon 24, which is used both for protecting the ureteral wall from trauma and also to aid in stone retention. In alternative embodiments, some of which are described below, wall protection member 24 may be something other than an inflatable balloon, such as a compliant cup or other form of compliant
- 20 material. Thus, use of the term “balloon” in describing the present embodiment should not be interpreted as limiting. Balloon 24 may also be used to help maintain a position of system 10 relative to the ureter, once it is inflated. Additionally, balloon 24 may be used during advancement or withdrawal of system 10 into or out of the ureter, to expand a portion of the ureter, for example to expand a constriction
- 25 or other narrowing of the ureter. Balloon 24 may be made of any suitable polymer, polymeric blend or other material or combination of materials. Generally, such material(s) will be relatively atraumatic to the ureteral wall and ideally will have a low-friction and/or hydrophilic outer surface or coating that facilitates sliding along the wall. In some embodiments, balloon 24 may be coated with a lubricious coating
- 30 and/or may include one or more small holes for allowing a lubricating fluid to escape.
- [0049] As will be described in further detail below, in one embodiment, end effector 18 may be advanced through the ureter to a location near the kidney stone.

The small, inner shaft, containing basket 20, may be extended out of outer shaft 16 during all, or at least part of, this advancement, and the whole device may be advanced until a distal end of the inner shaft is advanced beyond the stone. Basket 20 may then be advanced out of the inner shaft to allow it to expand, and the whole device may be pulled back to capture the stone. Camera 22 is coaxially located within the retention member shaft (or "basket shaft") and is positioned with its distal end at or near a distal end of the inner shaft and/or the retention member shaft, so that it faces into basket 20 to help visualize the stone and the process of capturing the stone. Once the stone is trapped in basket 20, inflatable balloon 24 may be inflated, typically until it contacts the inner wall of the ureter. Basket 20 and stone may then be pulled back proximally into the distal end of balloon 24, such that balloon 24 invaginates to receive and envelop at least part of basket 20 and stone. At this point, system 10 may be withdrawn from the ureter, with balloon 24 helping to prevent trauma to the ureteral wall and reducing the amount of force required to remove the stone. In some embodiments, irrigation fluid for enhancing visualization and/or lubrication may also be introduced into the ureter during the method. Although suction may also be used in some embodiments to help trap and/or retain the stone in basket 20, it is not a necessary component of the system or method. This is only one embodiment of a method for stone removal, and this embodiment and alternative embodiments are described in further detail below.

**[0050]** In one embodiment, handle extension 14 slides at least partially into and out of handle 12 to advance and retract one or more of the shafts of system 10. Handle extension 14 is an optional feature, and in alternative embodiments it may be eliminated. Additionally, the movements of the various shafts of system 10 described herein are exemplary in nature and should not be interpreted as limiting. Some shafts move relative to other shafts, and some shafts may be fixed relative to handle 12 or handle extension 14. For example, in one embodiment, camera 22 may be fixed to handle 12, so that it does not move during use of system 10, and instead, other parts move around it. This relationship may be advantageous, because it may reduce wear and tear on camera 22, which in some embodiments may be reusable. The inner shaft, which again will be shown and described in greater detail below, may also be fixed to handle 12 in one embodiment, so that the inner shaft covers most or all of the long, thin, flexible portion of camera 22 at all times. In alternative

embodiments, however, the various relative movements and relationships described herein may be changed, without significantly changing the overall function of system 10. Therefore, the descriptions of shaft movements, actuators, movement of handle extension 14 and the like should not be interpreted as limiting the scope of the invention as it is described in the claims.

**[0051]** In one embodiment, handle extension 14 is fixedly attached to outer shaft 16, such that handle extension 14 and outer shaft move together, relative to handle 12 and the inner shaft that houses basket 20. Handle extension 14 may slide in and out of handle 12 by manipulating shaft slider 30, which is fixedly attached to extension 14. Handle extension 14 may also include balloon fill port 26, which may be coupled with a source of balloon inflation fluid, such as but not limited to saline solution, water or contrast agent.

**[0052]** Handle extension 14 may also include irrigation port 28, which may be coupled with a source of irrigation fluid, such as but not limited to saline solution, water or a solution including a pharmaceutical agent, such as lidocaine. The irrigation fluid may exit system 10 near the distal (viewing) end of camera 22, for example out of a space between the distal end of the inner shaft and the distal end of the retention member shaft, or alternatively, through one or more irrigation fluid apertures on the inner shaft, the wall retention member or the like. Irrigation fluid may be used, for example, to help enhance visualization by keeping the distal end of the camera 22 clean and/or expanding a collapsed ureteral lumen, thus increasing the ability to visualize the lumen itself. Additionally, irrigation fluid may help to reduce friction while removing the kidney stone, to reduce pain, for example when lidocaine is used as lubricant, and/or for any combination of these or other purposes. In some embodiments, irrigation fluid may be passed out of the distal end aperture(s) or channel(s) at a low flow rate—for example, less than 5 cc/min. This low flow rate might be lower, for example, than flow rates typically used with currently available endoscopes for irrigation.

**[0053]** In one alternative embodiment, irrigation port 28 and balloon fill port 26 may be combined into a common port fluid infusion port. For example, in one embodiment, inflation fluid may also act as irrigation fluid by exiting out of the inflated balloon through one or more small apertures. Alternatively, fluid may enter

the combined port and may then be directed into a balloon inflation lumen and an irrigation fluid lumen.

5 [0054] Handle 12 couples with camera proximal portion 34 and also may include retention member slider 32, which is attached to the proximal end of the retention member shaft. Retention member slider 32 may be used to advance and/or retract basket 20 out of and/or into the inner shaft. Handle 12 also provides a portion of system 10 that a user may conveniently grasp with one hand. Slider(s) 30 and/or 32 may be manipulated with the same hand that holds handle 12 or with the opposite hand. Handle 12 and handle extension 14 may be made of metal, polymer, a  
10 combination of metal and polymer, or any other suitable material or combination of materials. Outer shaft 16 may be made of any suitable, biocompatible, flexible polymer. In some embodiments, system 10 may be fully disposable. In alternative embodiments, camera 22 may be reusable, and the rest of system 10 may be disposable. Finally, it may be possible that in some embodiments all of system 10  
15 may be reusable and sterilizable, such as by autoclave or other sterilization processes.

[0055] In some embodiments, the proximal end of outer shaft 16 may removably attach to the distal end of handle extension 14, for example by a snap-on fit in one embodiment. This snap-on configuration may have two primary advantages. First, outer shaft 16 may be attached to handle 12 after shaft 16 has been advanced into the  
20 ureter through an endoscope (such as but not limited to a cystoscope or steerable shaft) to position the distal end of shaft 16 in a desired location for stone removal. This allows the physician user to remove the endoscope after positioning the outer shaft 16 and prior to operation, improving patient comfort and ease of use. Second, handle 12 may be reusable, even if some or all of the rest of system 10 is disposable.

25 [0056] Referring now to FIGS. 2A and 2B, a distal portion of system 10 is illustrated in greater detail. In these figures, a kidney stone *S* is shown trapped inside basket 20. In some embodiments, balloon 24 may have several distinct portions, such as a proximal attachment portion 35 attached to outer shaft 16, a proximal tapered portion 36, a middle portion 37, a distal tapered portion 38 and a  
30 distal attachment portion 39 attached to a wall protection member shaft 42. Generally, it may be advantageous for proximal tapered portion 36 to have a more gradual taper than distal tapered portion 38. For example, in some embodiments, proximal tapered portion 36 may have a taper angle of between about 5 degrees and

about 25 degrees, and ideally between about 10 degrees and about 15, relative to a longitudinal axis of balloon 24. Distal tapered portion 38 may have a taper angle of between about 30 degrees and about 90 degrees, and ideally between about 40 degrees and about 70 degrees, relative to the longitudinal axis of balloon 24. In one  
5 specific example, distal tapered portion 38 may have a taper angle of about 45 degrees, and proximal tapered portion 36 may have a taper angle of about 10 degrees. The “steeper” taper angle of distal tapered portion 38 relative to that of proximal tapered portion 36 will cause distal tapered portion 38 to preferentially collapse into balloon 24 (or “invaginate”) when basket 20 and stone *S* are pulled back into distal  
10 tapered portion 38, rather than having any proximal tapered portion 36 collapse. Additionally, the steeper taper angle of distal tapered portion 36 may facilitate engulfing the stone with balloon 24 with less relative movement between outer shaft 16 and the inner balloon shaft.

**[0057]** FIG. 2B illustrates this preferential invagination of distal tapered portion  
15 38. Although distal tapered portion 38 is not visible in FIG. 2B, it has been pulled back into balloon 24 by basket 20 and stone *S*, which middle portion 37 and proximal tapered portion 36 remain relatively in the same configuration. As basket 20 and stone *S* are pulled further into balloon 24, part of middle portion 24 may be made to invaginate into the interior of balloon 24, and in this way all or part of stone  
20 *S* may be encircled by balloon 24. Basket 20 and stone *S* may be pulled proximally by sliding the retention member shaft (not visible here, because it is within wall protection member shaft 42 and the inner shaft) proximally, for example via a slider on handle 12 or handle extension 14. Pulling basket 20 and stone *S* proximally into  
25 balloon 24 invaginates. In some embodiments, distal attachment portion 39 and proximal attachment portion 35 may be of approximately equal lengths. Alternatively, they may have different lengths.

**[0058]** Balloon 24 may serve a number of different functions. For example, balloon 24 may reduce friction against the ureter wall by the trapped stone during  
30 removal, it may reduce trauma of the ureter wall by sharp edges of a trapped stone, and/or it may help retain the stone within system 10 in general. The retaining function may occur if balloon 24 surrounds the stone partially or completely and

thus helps with the trapping/retaining of the stone. In other words, balloon 24 and basket 20 may work together to trap and retain the stone.

**[0059]** In some embodiments, as an alternative or in addition to having different taper angles, distal tapered portion 38 and proximal tapered portion 36 may also have different thicknesses, be made of different materials, include one or more rigidity and/or flexibility features, and/or the like. In one embodiment, for example, proximal tapered portion 36 may be thicker than distal tapered portion 38, again to promote preferential collapse/invagination of distal tapered portion 38 before any other portion of balloon 24. In one embodiment, for example, a thicker balloon wall of proximal tapered portion 36 may be achieved in a dipping manufacturing process by dipping proximal tapered portion 36 more times than distal tapered portion 38. In another embodiment, where balloon 24 is formed using a balloon blowing process, an additional layer at proximal tapered portion 36 may be added after formation of balloon 24. This layer may be a simple adhesive, additional balloon material, or some other material that will bond to the blown balloon surface. Additionally or alternatively, the blown balloon 24 may be preferentially stretched to form a thinner distal tapered portion 38, thus creating the same or similar effective “strength differential” as might be achieved via a thicker proximal tapered portion 36.

**[0060]** In yet another alternative embodiment, proximal tapered portion 36 may include multiple rigidity features, such as longitudinally oriented ribs (not pictured). Such ribs may be formed, for example, during the blowing/dipping balloon formation process, by adding grooves in a mandrel used to form balloon 24. Alternatively, ribs may be added after balloon formation by applying axial lines of adhesive or other material that bond to the outer surface of balloon 24. Examples of such materials may include, but are not limited to, UV cure adhesive and polyurethane, nylon, and polyether block amide dissolved in a solvent solution. Alternatively, ribs made from polymer or metal strips may be bonded to outside of balloon 24. Ribs may be made out of a variety of materials and may provide additional proximal eversion resistance through increased thickness and/or by using a material of increased rigidity, stiffness and/or durometer.

**[0061]** FIG. 2A illustrates the fact that an optional feature of system 10 is one or more irrigation ports, apertures, openings or the like (not visible in the drawing) for providing irrigation fluid 40 at or near the distal end of system 10. Irrigation fluid

40 may serve the purpose, for example, of helping clean the lens of camera 22, clear the field of vision of camera 22, lubricate contact between system 10 and a ureteral wall and thus reduce friction during stone removal, and/or reduce pain in the case where lidocaine or some other anesthetic is infused into the site. In various  
5 embodiments, for example, fluid 40 may exit out of a distal end of system 10 via one or more small apertures in balloon 24 (for example laser-drilled holes that allow fluid to slowly weep out of balloon 24), via an irrigation lumen formed as a space between the inner shaft and the retention member shaft, between camera 22 and the inner shaft, or between the inner shaft and wall protection member shaft 42, or any  
10 other suitable fluid lumen or aperture(s). It may be advantageous, for example, to provide irrigation fluid close to the distal end of the camera, for clearing the field of view of the camera. This may be achieved, in some embodiments, by passing irrigation fluid through a space between the inner shaft and the retention member shaft.

15 **[0062]** Typically, only a low pressure of less than 1 atm is used to inflate balloon 24. This low pressure inflation enhances the ability of balloon 24 to invaginate and in some embodiments to be advanced around the obstruction. Lower pressures are also advantageous in preventing ureteral trauma associated with higher pressure and/or balloon diameters.

20 **[0063]** Once the obstruction is enveloped, it may often be easiest to remove the obstruction with balloon 24 partially or entirely deflated. In one embodiment, using the constant force of a passive syringe, coupled with removal system 10 and balloon 24 (via balloon inflation port 26), it is possible to allow balloon 24 to deflate automatically due to the force placed on balloon 24 when basket 20 and stone *S* are  
25 pulled back into balloon 24. In other words, the force and volume of basket 20 and stone *S* being pulled into balloon 24 reduces the capacity of balloon 24 to hold fluid volume, which in turn pushes the fluid back up the balloon inflation lumen toward balloon fill port 26 and an attached syringe (or other fluid infusion source). In the case where the infusion source is a syringe, this fluid pressure will be sufficient to  
30 push an unobstructed syringe plunger back, allowing balloon 24 to passively deflate. Other configurations employing stop valves and/or pressure monitoring are also possible, in alternative embodiments.

[0064] In some embodiments, to aid in detection, it may be beneficial to expand the ureter between the obstruction and the removal device. In particular, if the ureter is collapsed, then expanding it allows for better visualization. In the ureter, for example, about 1–2 cc of fluid can often provide a small amount of passive dilation  
5 (about 1–3 mm in a naturally closed orifice), which allows greater obstruction visualization. The dilation fluid used may be water, saline, or a combination of either with an analgesic agent. The fluid may be introduced into the lumen/vessel in a variety of ways. For example, a kidney stone removal device may emit a layer of fluid through relatively low-flow rate nozzles to dilate the ureter (“hydrodilation”).  
10 In various embodiments, for example, the flow rates used may be less than 20 cc/min. This fluid buffer/hydrodilation may be used, for example, to prevent body luminal wall trauma during obstruction removal. A number of nozzle profiles and hydrodilation techniques are described in Patent Application Serial No. 13/761,001, which was previously incorporated by reference. The infused liquid (or liquids) may  
15 include water, saline, lidocaine and/or other suitable liquid(s).

[0065] Additional dilation may also be achieved through small perforations in balloon 24, in some embodiments. Perforations on the order of 0.006” or smaller provide adequate dilation without necessarily flooding the lumen with fluid. In the case of the ureter, this implies minimizing renal pressure. Additionally, small  
20 perforations combined with a compliant balloon material allow for the perforations to effectively “seal” under lower pressures, allowing balloon 24 to inflate to a relatively low pressure without liquid leakage. As the pressure is increased, the balloon diameter and fluid pressure increase, allowing liquid to pass through the perforations and into the surrounding ureter or other vessel. This configuration may  
25 be advantageous for several reasons. First, it may help prevent over-inflation of balloon 24, by acting as a pressure release mechanism. Second, the released fluid may act as a lubricant, which will further facilitate stone removal. Third, the apertures may facilitate invagination of balloon 24.

[0066] A similar perforated design could be used in a non-compliant surface with  
30 smaller perforations. In this case, the increased water pressure alone would force the liquid from the non-compliant structure. In such embodiments, portions of the device on which it may be advantageous to add perforations include the instrument shaft, grasper shaft, or inner lumen side-wall, among others.

[0067] In various alternative embodiments, a smaller amount and/or flow rate of fluid may be introduced, for example to enhance visualization. This type of fluid introduction/irrigation may provide some amount of passive or slight dilation of the ureter but is not typically designed to provide hydrodilation.

5 [0068] With reference now to FIGS. 3A and 3B, one embodiment of system 10 is illustrated in side cross section and end-on cross section, respectively. Number labels for the components of system 10 are carried over to FIGS. 3A and 3B from those prior figures. Furthermore, neither FIGS. 3A and 3B nor any prior or subsequent figures are necessarily drawn to scale. Referring again to FIGS. 3A and  
10 3B, and moving from outside to inside, system 10 first includes outer shaft 16, which is attached at its distal end to proximal attachment portion 35 of balloon 24, and wall protection member shaft 42 (or “balloon shaft”), which is attached at its distal end to distal attachment portion 39 of balloon 24. Moving inward, the next component is an inner shaft 44, which has been referred to above but is not visible  
15 on previous figures. The next shaft moving inward is a retention member shaft 46, which extends distally into basket 20. As discussed above, retention member shaft 46 and basket 20 (or “stone retention portion”) may be referred to herein generally as a “stone retention member.” In some embodiments, such as the one illustrated in FIGS. 3A and 3B, the stone retention member is one piece, with retention member  
20 shaft 46 extending from a proximal end of system 10 to basket 20 at its distal end. In other embodiments, a separate retention member shaft piece may be attached to a separate stone retention portion piece to form the stone retention member.

[0069] Camera 22 is housed coaxially within retention member shaft 46, so that its distal end faces into basket 20. In at least one embodiment, camera 22 and inner  
25 shaft 44 are both fixed to handle 12, such that the distal end of camera 22 is positioned at or near the distal end of inner shaft. Retention member shaft 46, in this embodiment, is free to slide proximally and distally over camera 22 and within inner shaft 44. This allows basket 20 to be advanced out of, and pulled back into, inner shaft 44, while keeping camera 22 in a fixed position, thus reducing wear and tear on  
30 camera 22.

[0070] Some of the components of system 10 are movable, relative to other components. One embodiment is described here, but this is only one of a number of potential embodiments. In alternative embodiments, movement of components may

be entirely or partially changed, without departing from the scope of the invention. In one embodiment, outer shaft 16 may be fixed to handle extension 14 and thus may slide back and forth relative to handle 12 as handle extension 14 slides back and forth. Wall protection member shaft 42 may be attached to a slider on handle 12 or  
5 handle extension 14. In some embodiments, wall protection member shaft 42 may tightly contact the inner wall of outer shaft 16 and may simply move in conjunction with outer shaft 16 via friction force and/or may slide proximally when the stone and basket 20 are pulled into balloon 24. As mentioned above, inner shaft 44 may be fixedly coupled with handle 12, so that it does not move relative to handle 12.  
10 Finally, retention member shaft 46 (or “basket shaft”) may be coupled proximally with slider 32 on handle 12, so that retention member shaft 46 may be advanced to advance basket 20 out of inner shaft 44. Inner shaft 44, in turn, may be exposed out of the distal end of outer shaft 16 by pulling back on handle extension 14 to pull outer shaft 16 proximally relative to inner shaft 44. In one embodiment, system 10  
15 may be advanced through the ureter with inner shaft 44 extended out of the distal end of outer shaft 16. Alternatively, outer shaft 16 may be retracted later in the process, for example when system is already advanced to a treatment location, to expose inner shaft 44. Either way, the entire system 10 may then be advanced, once inner shaft 44 is extended out of outer shaft 16, to pass the distal end of inner shaft  
20 44 around and past the stone. Basket shaft 46 may then be advanced to expose basket out of the distal end of inner shaft 44. The whole system 10 may then be retracted to trap the stone in basket 20. Camera 22, meanwhile, may be fixedly, though removably, coupled with handle 12, so that it remains in a fixed position relative to the moving components during the process. These and other steps of one  
25 method embodiment will be described in further detail below.

**[0071]** As mentioned previously, wall protection member shaft 42 may be mobile relative to outer shaft 16. For example, it may be possible to retract wall protection member shaft 42 as basket 20 and stone are pulled back into balloon 24. Alternatively or additionally, wall protection member shaft 42 may passively move  
30 back as basket 20 and stone are pulled into balloon 24. Moving at least some of the components of system 10 relative to other components allows kidney stone removal (or other obstruction removal from other body lumens) using the method briefly

described above and described in more detail below. The various components may be made of any suitable materials, such as flexible polymers.

[0072] As mentioned above, this combination of moving parts of system 10 may be altered in alternative embodiments. For example, it may be possible in one  
5 embodiment to fix outer shaft 16 to handle 12 and have inner shaft 44 slide in and out of outer shaft 16. This is just one potential change that might be made, and the embodiment described here is simply to provide an example.

[0073] FIGS. 4A–4E illustrate one embodiment of a method for using system 10 to remove a kidney stone from a ureter (or other obstructions from other lumens, in  
10 alternative embodiments). FIGS. 4A–4E are not drawn to scale. First, as illustrated in FIG. 4A, the distal end of the kidney stone removal system 10, here shown as outer shaft 16 and balloon 24, is advanced into a ureter U to a position near a kidney stone S, just below the obstruction. Shaft 16 and balloon 24 may be advanced  
15 through any suitable endoscope device, steerable shaft, catheter or other introducer device, such as but not limited to a cystoscope (not shown). In some embodiments, camera 22 may be used to visualize/detect the kidney stone S and monitor advancement of system 10 to a desired location in the ureter U relative to the stone S. Next, as illustrated in FIG. 4B, balloon 24 may be inflated, which may help maintain a position of shaft 16 in the ureter U. Then, inner shaft 44, containing basket 20,  
20 retention member shaft 46 and camera 22, is advanced past the stone S. Camera 22 may be used to visualize this advancement as well.

[0074] As shown in FIG. 4C, basket 20 may next be advanced out of inner shaft 44, allowing basket 20 to expand. Again, camera 22 may be used to visualize advancement and expansion of basket 20. Next, as illustrated in FIG. 4D, basket 20  
25 may be drawn back proximally (retracted toward outer shaft 16) to capture the stone S by retracting the entire system 10. This step may also be visualized using camera 22. Finally, as illustrated in FIG. 4E, the stone S and basket 20 may be pulled back into balloon 24, by pulling retention member shaft 46 proximally, thus causing balloon 24 to invaginate and at least partially surround the stone S. Balloon 24 will  
30 help prevent damage to the wall of the ureter as the stone S is removed, by enveloping the sharp edges of the stone S and thus providing a low-friction surface. The stone S may then be removed by pulling shaft 16 and balloon 24 out of the

ureter. Due to the location of camera 22 at or near the distal end of inner shaft 44, any or all of these steps may be visualized via camera 22.

5 [0075] One optional step may involve dilating one or more areas of the ureter by inflating balloon 24 at any point during the stone capture and/or stone removal process. This may be useful, for example, if the system 10 is being removed from the ureter and a constricted or narrowed area is encountered. In one embodiment, balloon 24 may be inflated to dilate at such an area, and then the inflation device, such as a syringe, may be used to actively deflate balloon 24 partially, or alternatively it may simply be allowed to automatically retract to deflate balloon 24  
10 to a nominal pressure for continued removal of system 10 from the ureter.

[0076] In some embodiments, handle 12 may include a coupler for coupling camera 22 with inner shaft 44, so that camera 22 is always located at the tip of the inner shaft 44. This ensures full visualization, while preventing having camera 22 protrude beyond the distal end and thus risk being damaged. Some embodiments  
15 may also include a frictional fit of basket 20 in inner shaft 44, such that basket motion will be coupled to camera 22 and shaft 44 when not actively controlled by the user, thus eliminating the need to move two sliders at once, while de-coupling the two when active, independent basket control is required. Other unique features of handle 12 are the dual-slider configuration and overall handle shape, which allow  
20 single-handed actuation. Yet another feature is the balloon inversion/invagination that is caused by sliding retention member slider 32 until the captured stone is pulled against the tip of wall protection member shaft 42. Further motion of basket slider 32 causes wall protection member shaft 42 to slide proximally relative to the stationary outer shaft 16, which in turn causes balloon 24 to invaginate/invert. This  
25 design eliminates the need for an additional “invagination slider.” In some embodiments, however, wall protection member shaft 42 will, in fact, be attached to a slider. In some embodiments, this slider may be used to return balloon 24 to its original pre-invagination shape. Such a slide may also be used, of course, to invaginate balloon 24 if necessary.

30 [0077] With reference now to FIGS. 5A–5F, another embodiment of a method for removing a kidney stone using system 10 is illustrated. In this embodiment, as illustrated in FIG. 5A, the distal end of the kidney stone removal system 10 is advanced through a ureter U with inner shaft 44 already extended out of the distal

end of outer shaft 16 and with balloon 24 deflated. As illustrated in FIG. 5B, all of system 10 may then be advanced further, to position a distal end of inner shaft 44 past the stone *S*. Still, balloon 24 is in a deflated configuration. As shown in FIG. 5C, basket 20 may next be advanced out of inner shaft 44, allowing basket 20 to expand. Next, as illustrated in FIG. 5D, basket 20 may be drawn back proximally (retracted toward outer shaft 16), by retracting the entire system 10, to capture the stone *S*. At this point, as illustrated in FIG. 5E, balloon 24 may be inflated. Finally, as shown in FIG. 5F, basket 24 and stone *S* may be pulled back into balloon 24.

**[0078]** In some cases, this embodiment of the method may be simpler and/or easier to perform than the embodiment described previously. As should be evident from these embodiment descriptions, however, any given method embodiment may include any suitable number of steps and order of steps. Some steps may be eliminated and/or added in various alternative embodiments, without departing from the scope of the invention.

**[0079]** With reference now to FIGS. 6A and 6B, in an alternative embodiment, a kidney stone removal system 110 may include an end effector 118 that has a compliant funnel 124 (or “obstruction shaft”), rather than a balloon, to provide protection for the ureteral wall. End effector 118 may also include an expandable basket 120, a camera 122 and one or more irrigation ports for providing irrigation fluid 140. System 110 may include an outer shaft 116 and some or all of the other components described above in relation to other embodiments. Due to the substitution of funnel 124 for a balloon, however, the design of system 110 may be somewhat simpler. For example, system would not include a wall protection member shaft or a balloon inflation port. Funnel 124 acts in the place of the balloon as a guard against ureter wall trauma during stone removal. As such, funnel 124 may be made of any suitable polymer or other material that helps reduce or minimize friction and/or that can serve as a protective layer to reduce trauma from sharp edges of kidney stones. As illustrated in FIG. 6B, basket 120 and stone *S* may be drawn back proximally into funnel 124, just as in the embodiment with the balloon, except that funnel 124 does not invaginate or invert. Camera 122 may be positioned at or near the distal end of funnel 124, for visualizing the removal procedure. In alternative embodiments, funnel 124 may be replaced with any other suitable protective, friction/trauma reducing device, such as a shaft, cup, sock,

lubricated surface or the like. Optionally, system 110 may include additional ports or apertures, for example at or near the juncture of funnel 124 and shaft 116, for providing lubricating fluid to further facilitate stone removal.

5 [0080] Expandable basket 120 may have a shape that facilitates the expansion of compliant funnel 124 around the stone *S* and basket 120. As illustrated in FIG. 6A, in some embodiments, expandable basket 120 may have a tapered shape from the portion that retains the stone *S* toward the connection of basket 120 with the basket shaft (not shown). The tapered shape may help align and expand compliant funnel 124 around the kidney stone *S* or other obstruction. The expansion of basket 120  
10 may also be used to expand compliant funnel 124 around the obstruction. Using basket 120 to expand compliant funnel 124 makes funnel 124 a passive component, reducing overall complexity of system 110.

[0081] Prior to use, compliant funnel 124 often needs to be retained in such a way that it does not catch or rub on either the working channel of the introducing device  
15 (cystoscope or other endoscope, for example) or the wall of the body lumen during advancement. One solution would be to provide system 110 with an outer shaft that can slide over funnel 124 to prevent it from expanding prior to capturing the obstruction. Due to space constraints, however, it may be advantageous to eliminate an external shaft from the device assembly. One such solution is to invert funnel  
20 124 inside outer shaft 116 around basket 120 during advancement to the obstruction. When basket 120 is advanced out of the main assembly, funnel 124 is deployed into position (as in FIG. 6A). A variety of variations to this deployment method using other aspects of catheter assembly (camera lumen or fluid introduction lumen, for example) may be possible and will all function in an essentially equivalent manner  
25 to the above embodiment.

[0082] The embodiments thus far have involved systems in which expandable baskets are used to trap a stone and pull it back into a protective element, such as a balloon or compliant funnel. A different group of embodiments eliminates the expandable basket and instead traps the stone or other obstruction from the side of  
30 approach of the device toward the stone. For example, these embodiments typically involve expandable graspers or expandable funnels that are advanced directly over/around the stone and thus used to pull the stone out of the ureter. Some of

these embodiments may also involve the use of suction to help pull the stone into the grasper. Several examples of such embodiments are described further below.

**[0083]** With reference now to FIGS. 7A and 7B, one example of an expandable grasper 210 that may be used to retain a stone or obstruction may include multiple struts 213, each having a hooked distal tip 214. As illustrated in FIG. 7A, the struts 213 are typically joined together at a proximal end 215. (FIG. 7B is a close-up view of several struts 213 and distal tips 214.) Expanding grasper 210 may include any suitable number of struts 213, and struts 213 may include any of a number of differently shaped distal tips 214, according to various alternative embodiments. In some embodiments, distal tips 214 of struts 213 of expandable grasper 210 may be folded inward to form hooks or “teeth,” to help retain the kidney stone within grasper 210. Typically, although not necessarily, grasper 210 will be combined with some form of protective coating, membrane, balloon or other protective component to reduce or minimize trauma to the ureteral wall during stone removal. When grasper 210 is advanced out of a shaft in which it is housed, it will expand to a diameter sufficient to grasp a kidney stone. When grasper 210 is then at least partially retracted (drawn back) into the shaft, grasper 210 will contract at least slightly to grasp and hold the kidney stone.

**[0084]** In some embodiments, expanding grasper 210 may be configured to expand automatically when released from a shaft. In such embodiments, for example, expanding grasper 210 may be made by shape setting Nitinol or pre-bending an elastic material such as spring steel or PEEK into the desired expanded geometry. The geometry can then be elastically compressed into a much smaller (unexpanded) shape within the shaft (for example, catheter shaft having a diameter of 6 French or smaller). Expanding grasper 210 may be deployed by advancing grasper 210 out of the shaft and/or sliding the shaft back from the grasper 210. Both result in less constraint on the grasper 210, causing struts 213 to spread apart at their distal ends, thus increasing the diameter of the distal end of grasper 210.

**[0085]** Referring to FIGS. 8A and 8B, another alternative embodiment of a stone removal device 220 may include an outer shaft 216, an expandable grasper 226, with multiple struts and curved distal tips 228, and a protective membrane 224 positioned around grasper 226. FIG. 8B shows device 220 in place within a ureter U and partially surrounding a kidney stone S. In various embodiments, membrane 224

may be made of any suitable polymer or other flexible material and may be configured to prevent trauma to an inner wall of the ureter *U* once the kidney stone *S* is captured therein. In various embodiments, membrane 224 may be one layer of material, multiple layers of material, an inflatable balloon, a funnel, a cup, a sock or the like. In some embodiments, grasper 226 and membrane 224 may be housed within outer shaft 216 during advancement of device 220 through the ureter, and then advanced out of the end of outer shaft 216 to expand and then trap a kidney stone *S*. In some embodiments, and with reference to FIG. 7B, grasper 226 and membrane 224 may expand until they match or slightly exceed the horizontal diameter of the kidney stone *S* to be removed. In some embodiments, grasper 226 may be advanced out of outer shaft 216 by an amount that achieves a desired diameter.

**[0086]** FIG. 8B illustrates part of a method for removing a kidney stone *S* from a ureter *U*, using removal system 220. As illustrated here, system 220 is advanced to a location in the ureter *U* adjacent the stone *S*. Expandable grasper 226 is then advanced out of outer shaft 216 (and/or outer shaft 216 may be retracted back from grasper 226), to allow grasper 226 to expand to its expanded, default configuration, such that distal tips 228 are configured in a diameter as wide or wider than the stone *S*. Grasper 226 may then be advanced over the stone *S*, thus capturing the stone *S* in grasper 226. Protective membrane 224 acts to protect the inner wall of the ureter *U* while removal system 220 is used to pull the stone *S* out of the ureter *U*.

**[0087]** In some embodiments, a kidney stone removal system may include, or may be used in a system including, a mechanism for dilating the ureter. For example, in one embodiment, a stone removal system may include a balloon that encases grasper 210 or 226. The balloon may be infused with air, water, saline, a biocompatible lubricant, a local anesthetic (such as lidocaine), any other suitable substance, or a combination of any of these substances, to achieve a desired viscosity, cost, and/or performance. The balloon may provide a smooth surface around the obstruction, reducing removal friction and facilitating passage. In addition, the balloon can be integrated in such a way that inflation causes an additional retention force on the obstruction by inflating the side of the balloon on the inside of struts around the stone.

**[0088]** In alternative embodiments, dilation of the ureter (or other body lumen in other embodiments) may be performed via hydrodilation, without the use of a balloon. Numerous embodiments of devices and methods for hydrodilation of body lumens, such as the ureters, are described in pending U.S. Patent Application Serial  
5 No. 13/716,001 (Pub No. 2013/0165944), entitled “Apparatus, Systems, and Methods for Removing Obstructions in the Urinary Tract,” the full disclosure of which is hereby incorporated by reference herein. Many of the embodiments described in the above-reference patent application use jets to propel fluid against the wall of the ureter to provide hydrodilation. These embodiments may be  
10 combined with the embodiments described herein, such that the hydrodilation jets may be used to dilate up and around a kidney stone from the proximal end (or “base”) of an expandable grasper, for example. Alternatively, in one embodiment, hydrodilation may be achieved by ejecting fluid out of hollow tines of an expandable grasper (not illustrated)—i.e., using hollow grasping members as water channels  
15 with holes near the tips for water ejection.

**[0089]** Referring to FIG. 9, in another alternative embodiment, a kidney stone removal device 230 may include an expandable grasper having multiple struts 234 with hooked distal tips 238, a dilation balloon 232 coupled with struts 234, and a shaft 236 for containing the grasper and balloon 234 during delivery into the ureter.  
20 Dilation balloon 232 may include multiple apertures 240 (or “holes” or “perforations”) to allow fluid 242 to pass from balloon 232 into the region around the obstruction. For example, a local anesthetic may be used to numb the region around the obstruction, a lubricant may be desired for further reduction of friction around the stone, and/or any of the fluids mentioned above may be used to provide  
25 hydrodilation force around balloon 232 to reduce friction and/or tissue trauma.

**[0090]** In the embodiment illustrated in FIG. 9, balloon 232 is positioned on removal device 230 on the outside of struts 234. Balloon 232 may be infused with air, water, saline, a biocompatible lubricant, a local anesthetic (such as lidocaine), any other suitable substance and/or a combination of substances. Attaching balloon  
30 232 to the outside surface of struts 234 allows struts 234 to have hooks 238 (or teeth, etc.) to increase the retention force on the stone, without risk of balloon perforation.

**[0091]** Referring now to FIG. 10, as mentioned above, any of the embodiments of obstruction removal devices described herein may include, or may be used with a

system that includes, one or more obstruction detection components. These obstruction detection components may be specifically configured for kidney stone detection in some embodiments. FIG. 10 illustrates another embodiment of a kidney stone removal device 250, including an expandable grasper having multiple struts 254 with hooked distal tips 258, a compliant membrane 252 coupled with struts 254, one hollow strut 262, a small camera 260 extending through the lumen of hollow strut 262, and a shaft 256, which the other components are advanced out of and retracted back into. In one embodiment, for example, hollow strut 262 may have a lumen with an inner diameter of about 0.4 mm. This lumen is large enough for a small fiber camera 260 to visualize a kidney stone directly. Illumination for small fiber camera 260 may be provided, in some embodiments, around the sides of camera 260. Alternatively, illumination may be provided via a light source, such as a fiber, directed through a central lumen of shaft 256. In various alternative embodiments, fiber camera 260 may be either reusable or disposable. In other alternative embodiments, an inductance coil or impedance sensor may be included for detection purposes, for example for use in smaller lumens.

**[0092]** Referring now to FIGS. 11A and 11B, in another embodiment, a kidney stone removal device 270 may include an expandable mesh grasper 272, positioned inside an inflatable balloon 274 (or alternatively a membrane or other friction reducing/protective member), and a shaft 276 for housing both. In one embodiment, expandable mesh grasper 272 may be made of a shape-memory material and may have a configuration similar to that of a vascular stent. Grasper 272 may be constructed from a number of highly compliant materials, such as Nitinol, spring stainless steel, or PEEK plastic, among others. The geometry can then be elastically compressed into a much smaller (unexpanded) shape within shaft 276 (for example, a 6 French catheter shaft). Grasper 272 may then be deployed by advancing grasper 272 out of shaft 276 and/or sliding shaft 276 back from the grasper 272. Either of these methods results in reduced constraint on the expandable member 272, causing the tip diameter to increase. This diameter can then be expanded until it matches the horizontal diameter of the stone. In some embodiments, the tips of expandable grasper 272 may be turned/folded inward to form “teeth” to help retain the stone, similar to the hooks/teeth described above. As mentioned above, in various

alternative embodiments, expandable grasper 272 may be combined with any other suitable protective member in place of balloon 274.

**[0093]** Referring to FIG. 11B, in some embodiments, balloon 274 may be infused with air, water, saline, a biocompatible lubricant, or a local anesthetic (such as lidocaine). A combination of any of the above may also be used to achieve a desired viscosity, cost, clinical performance, functional performance, and/or the like. Balloon 274 creates a smooth surface around the obstruction, reducing removal friction and facilitating passage. In addition, balloon 274 may be integrated in such a way that inflation causes an additional retention force on the stone by inflating the side of balloon 274 on the inside of mesh grasper 272 around the stone. As described above in relation to other embodiments, balloon 274 may also include apertures or perforations to allow fluid to pass from balloon 274 into the region around the obstruction. For example, a local anesthetic may be used to numb the region around the obstruction, a lubricant may be desired to reduce the friction of the obstruction on the surrounding wall, or any of a number of fluids may be used to provide a hydrodilation force around balloon 274 to reduce friction and/or tissue trauma.

**[0094]** As illustrated in FIG. 11B, in some embodiments, balloon 274 may be positioned on the outside surface of mesh grasper 272. Having the balloon attached solely to the outside surface of balloon 274 allows grasper 272 to have “teeth” to increase the retention force on the stone without risk of balloon perforation.

**[0095]** Referring now to FIG. 12, in another alternative embodiment, a stone removal device may include an expandable mesh grasper 280 that includes a mesh 282 and webbing 284 disposed between or over mesh 282. Webbing 284 may comprise a highly compliant material, which may be applied to mesh 282 via a dipping process, for example, thus forming a smooth surface for the natural dilation created by grasper 280, and thus reducing the friction required for obstruction removal. In one embodiment, a hydrodilation fluid may be emitted from a portion of webbing 284. Alternatively, hydrodilation fluid may be provided using any of the methods described above. In one embodiment, webbing 284 may serve as the protective element, eliminating the need for an additional element, such as a balloon, funnel-shaped membrane or the like.

[0096] Referring now to FIGS. 13A and 13B, a distal portion of another alternative embodiment of a kidney stone removal device 290, including a protective balloon 292 is illustrated. Device 290 may include balloon 292, an outer shaft 298, and an inner shaft 296 that moves in and out of shaft 298. Balloon 292 may include  
5 a distal tapered portion 293 and an inner, stone entrapment space 294. When inner shaft 296 is fully advanced, stone entrapment space 294 is rolled outwards and becomes tapered portion 293 (as in FIG. 13A). When inner shaft 296 is pulled back/retracted proximally, back into outer shaft 298, tapered portion 293 rolls inward (or “invaginates”) to form stone entrapment space 294.

10 [0097] In one embodiment, a method for using device 290 may involve advancing the distal end of device 290 into the ureter to a position near a kidney stone. Balloon 292 may then be partially inflated and then advanced around the obstruction from the direction of approach of device 290, such that the kidney stone becomes trapped in entrapment space 294. Balloon 292 may then optionally be inflated further, using  
15 any suitable inflation medium provided via a central lumen or specified inflation lumen(s) of shaft 298. This method of approaching and capturing the kidney stone is advantageous, because it eliminates the complexity of manipulating the device past the obstruction. This embodiment of device 290 may also reduce body lumen trauma and friction that results from the catheter lumen placement adjacent to the  
20 stone. Balloon 292 (or other compliant material member in alternative embodiments) will typically have a tapered shape and thickness configured to facilitate enveloping the stone without necking or forcing the stone out of balloon 292 during deployment. In various embodiments, for example, balloon 292 may include a tapered portion at its distal end with an angle of between about 2 degrees and about 45 degrees.  
25

[0098] FIG. 13A shows device 290 with inner shaft 296 extended out of shaft 298 to its maximum extent. FIG. 13B shows inner shaft 296 retracted to pull back on the distal end of balloon 292, thus forming entrapment space 294. In some  
embodiments, balloon 292 may be rolled over a stone or other obstruction by  
30 retracting inner shaft 296 and advancing outer shaft 298. Alternatively, it may be possible to achieve the same or similar effect by only retracting inner shaft 296 or only advancing outer shaft 298. Whichever method is used, entrapment space 294 may be formed to entrap the kidney stone for removal.

**[0099]** With reference now to FIG. 14A, in an alternative embodiment, a kidney stone removal device 300 may include a balloon 302, an outer shaft 308, and an inner shaft 306 that moves in and out of shaft 308. Balloon 302 may include an inner, stone entrapment space 304 and a distal, tapered portion 303. Inner shaft 306  
5 may include a rigid, distal ring 307 or platform, which connects shaft 306 to the inside edge of a slightly inverted balloon 302. The outside of balloon 302, attached to movable inner shaft 306, can be extended around the kidney stone or other obstruction. Ring 307 may be positioned to sit on the bottom of the stone/obstruction, and balloon 302 may be advanced around the stone to enclose the  
10 stone in entrapment space 304. Ring 307 may help prevent the bottom portion of the inverted balloon 302 from “necking down,” which may help facilitate obstruction entrapment by balloon 302. The phenomenon of “necking down” refers to the narrowing of balloon 302 in the area where it connects to shaft 66, which can be seen in FIG. 13B.

**[0100]** With reference now to FIG. 14B, an alternative embodiment of a stone removal device 300' with a differently shaped ring 307' is illustrated. In all other ways, device 300' is the same as shown in FIG. 14A and includes a balloon 302' with a tapered portion 303' and an inner space 304', an outer shaft 308', and an inner shaft 306' that moves in and out of shaft 308'. In this embodiment, ring 307'  
20 may have an atraumatic configuration so that when inner shaft 306' is fully advanced, ring 307' will not inadvertently damage other structures. In one embodiment, a tapered compliant material could be attached to the tip of balloon 302' to increase the rigidity of the tip section relative to balloon 302'. This tapered section will provide additionally rigidity to the tip, and can prevent balloon 302' from necking down to a small diameter as it is deployed over the obstruction, similar  
25 to the function of ring 307' at its attachment with balloon 302'. This material may also serve as an atraumatic trip during catheter deployment, and may be superior in the case of tapered balloon 302', as it will conform to the balloon shape.

**[0101]** In any of the above-described embodiments, suction force may be used to  
30 help draw a kidney stone or other obstruction into the entrapment space in the balloon. In some embodiments, suction force may be applied via a central lumen in the inner shaft of the obstruction removal device, so that the suction force is applied directly inside the entrapment space of the balloon.

[0102] It is possible to combine any of the above-described removal methods. A combination of the above may be preferable in some embodiments, depending on the obstruction location, size, required retention force and/or other factors.

[0103] In all the embodiments described above in relation to FIGS. 13A, 13B, 5 14A and 14B, the retention member, namely the balloon, also acts as the wall protection member. The two-sided compliant material, which is described above as a balloon but which may have other configurations in alternative embodiments, may be partially infused with air, water, saline, a biocompatible lubricant, or a local anesthetic (such as lidocaine) then rolled or linearly extended past the stone. In 10 some embodiments, as mentioned above, the dilation balloon may be perforated to allow at least some of the fluid to pass into the region around the obstruction. For example, a local anesthetic may be used to numb the region around the obstruction, a lubricant may be desired to reduce the friction of the obstruction on the surrounding wall, or the fluid may be used to provide a hydrodilation force around 15 the balloon to reduce friction and/or tissue trauma.

[0104] Any of the embodiments described above in relation to FIGS. 13A, 13B, 14A and 14B may also include some form of visualization component. In some 20 embodiments, for example, a visualization device may extend through a central lumen of the moveable inner shaft, thus providing visualization into the entrapment space of the balloon. In a 6F catheter, a typical size deployed through the working channel of an endoscope, this inner lumen could be upwards of 1 mm (3 F). This would allow both a light source and fiber camera to be deployed down the central lumen for visualization.

[0105] In some embodiments, a stone removal system may be configured without 25 one or more of the previously-described shafts. Such embodiments may have a simpler design than that of previously-described embodiments, which may facilitate simpler articulation of the device and reduced overall complexity. Further, such embodiments may have a smaller diameter, which may provide advantages in deployment and usage, such as reduced procedure times, reduced cost, and increased 30 usability.

[0106] FIGS. 15A and 15B illustrate one alternative embodiment of a stone removal system 410. Stone removal system 410 and its components may include characteristics of the previously described stone removal systems, including but not

limited to those shown and described with regard to FIGS. 3A and 3B. For example, stone removal system 410 may include an outer shaft 416, a retention member 420, a camera 422, a wall protection member 424, an inner shaft 442 and a retention member shaft 446. Wall protection member 424 may be connected between outer shaft 416 and inner shaft 442. An attachment point 443 between inner shaft 442 and wall protection member 424 may be located at approximately distance  $d$  away from a distal end of inner shaft 442. In some embodiments, stone removal system 410 may include one fewer shaft than device 10 of FIGS. 3A and 3B. Such embodiments may facilitate a reduction in diameter of outer shaft 416 by approximately 1 French (approximately 0.33 mm), compared to device 10.

[0107] In some embodiments, one or more shafts may have multiple functions, thereby facilitating a reduction in the total number of shafts. For example, inner shaft 442 may act as a sheath for retention member 420 and may have attachment point 443 for wall protection member 424. In some embodiments, a distal portion of wall protection member 424 may be attached to a distal portion of inner shaft 442 at attachment point 443. Attachment point 443 may be located at a number of different locations on inner shaft 442, such as on an inner surface or an outer surface of inner shaft 442, proximally spaced from the distal end of inner shaft 442, or at the distal tip of inner shaft 442. In the embodiment shown in FIG. 15A, attachment point 443 is located on an outer surface of inner shaft 442, proximally spaced from the distal end of inner shaft 442 by distance  $d$ . Locating attachment point 443 on an outer surface of inner shaft 442 may help avoid interference with deployment of retention member 420, as compared to an embodiment in which attachment point 443 is located on the inner surface of inner shaft 442. Further, spacing attachment point 443 by distance  $d$  may advantageously allow for the tip of system 410 to be advanced past a stone without having to also advance wall protection member 424 past the stone. Distance  $d$  may be selected to provide sufficient distance for the distal end of inner shaft 442 to be advanced past a stone with additional distance to allow some margin for manipulation of system 410. In some embodiments distance  $d$  is about 5 mm to about 20 mm, about 8 mm to about 15 mm, about 8 mm to about 10 mm, or other distances. In some embodiments, it may be advantageous for distance  $d$  to be no longer than necessary to advance the distal end of inner shaft 442 past a stone without also advancing attachment point 443 to or past the stone.

Shorter distances  $d$  may make balloon invagination easier because, in some embodiments, increasing distance  $d$  may correspondingly increase the distance the stone is retracted before it reaches wall protection member 424. [Regarding the distance between the distal tip of the inner shaft and attachment point 443 of wall protection member 424, is there a particular distance that should be described? What advantage is provided by this spacing?]

[0108] FIGS. 16A and 16B illustrate another alternative embodiment of a stone removal system 510, including an outer shaft 516, a retention member 520, a wall protection member 524, an inner shaft 542, and a retention member shaft 546. The configuration of stone removal system 510 of FIGS. 16A and 16B may facilitate a reduction in size of stone removal system 510 compared to other embodiments. Wall protection member 524 may be connected between outer shaft 516 and inner shaft 542, and there may be an attachment point 543 between inner shaft 542 and wall protection member 524 located at approximately distance  $d$  away from distal tip of inner shaft 542. In some embodiments, stone removal system 510 may have a diameter of approximately 3 French (approximately 1 mm). Some embodiments do not include a camera inserted through retention member shaft 546. This enables retention member shaft 546 to be configured with a reduced size. In addition, retention member shaft 546 may be configured as one or more wires or solid shafts as opposed to, for example, a tubular luminal structure. This further enables reduction of diameter of outer shaft 516.

[0109] Using one or more designs described above (e.g., by removing a camera), the catheter diameter (e.g., the diameter of outer shaft 516) may be reduced to approximately 3 F (1 mm) in diameter, between approximately 2.5 F and 6 F in diameter, or other sizes. The overall diameter of stone removal system 510 may be selected based on a particular working channel through which it may be fed. Some embodiments may be configured such that a catheter may operate with existing 3 F to 4 F working channel endoscopes, such as flexible ureteroscopes, which may have a working channel with a size of approximately 3.4 F, approximately 3.2 F to approximately 3.8 F, or other sizes. In another example, stone removal system 510 may be adapted to be fed through the working channel of a cystoscope that has a working diameter of approximately 6 F. Some embodiments may be operated in conjunction with ancillary visualization such as direct vision provided by a

ureterscope or fluoroscopy. Such ancillary visualization could be used in addition to or instead of direct visualization provided by the embodiment itself.

5 [0110] In some embodiments, a stone removal system (e.g., stone removal system 410 or stone removal system 510) may include a guide wire, laser fiber, or other component. Such components may be in addition to or instead of a camera (e.g., camera 422).

10 [0111] For example, a system may include a guide wire port and a lumen compatible with a guide wire (e.g., a standard size guide wire, such as a 0.018" diameter guide wire). The guide wire may facilitate the use of the system to with fluoroscopy. In some embodiments, the guide wire may run coaxially with the other components of the system to a stone retention member. In some embodiments, the guide wire may run adjacent to another component of the system, such as through a central lumen. In some embodiments, a catheter of a system with a guide wire may have an outer shaft diameter of approximately 3.5 F to 4F, approximately 4 F to 5 F, or another size.

15 [0112] As another example, a system may include a laser fiber port and a lumen compatible with a laser fiber. The laser fiber may be configured to apply laser energy to a stone or other target as part of, for example, laser lithotripsy. In some embodiments, the laser fiber may be a 100–200 micron laser fiber. The system may include a lumen (e.g., a hypotube) having an inner diameter of approximately 0.005" to 0.009" to accommodate the laser fiber. The laser fiber may run coaxially with other components of the system to a stone retention member. In some embodiments, the laser fiber may run adjacent to and/or coaxially with another component of the system, such as through a central lumen. The laser fiber may be configured to allow an obstruction (e.g., a stone) to be grasped and fragmented. This could help provide a more efficient use of an endoscope's working channel in embodiments where systems 410 and 510 are deployed through a working channel of another endoscope.

20 [0113] FIG. 17 illustrates another embodiment of a stone removal system 600, including an eversion mechanism 602, a retention member mechanism 604, a handle 612, an outer shaft 616, an end effector 618, a retention member 620, a wall protection member 624, and an inner shaft 642. Retention member 620 may be connected to retention member shaft 646 (not shown). Stone removal system 600

may include one or more characteristics of systems disclosed herein, including but not limited to systems 410, 510.

5 [0114] Actuation of eversion mechanism 602 or retention member mechanism 604 may cause actuation of one or more shafts of system 600. Eversion mechanism 602 may be configured to actuate wall protection member 624 to cause at least partial eversion of wall protection member 624. The words “invert” and “evert” may be used interchangeably herein to describe the invagination of a wall protection member 624 or other component disclosed herein. Eversion mechanism 602 may be connected to inner shaft 642 (to which wall protection member 624 may be attached),  
10 such that actuation of eversion mechanism 602 causes movement of inner shaft 642 relative to one or more of the other shafts. Retention member mechanism 604 may be connected to retention member 620 and/or retention member shaft 646, and actuation of retention member mechanism 604 may cause movement of retention member 620 and/or retention member shaft 646 relative to one or more of the other  
15 shafts. In some embodiments, the mechanism may be a lever, a knob, a wheel, a slider, a button, or other mechanism by which input may be received. In some embodiments, the user does not directly engage with the mechanism. Instead, for example, the movement of other portions of system 600 may provide input to actuate the mechanism without the user directly manipulating the mechanism.

20 [0115] In some embodiments, there may be one or more other mechanisms for actuating one or more other shafts or components. For example, handle 612 may include a mechanism configured to move outer shaft 616 or a mechanism configured to move a camera 622 or other component inserted into a lumen of system 610. Handle 612 may include a mechanism configured to move two or more of the shafts  
25 or other components. For example, handle 612 may include a mechanism configured to move any combination of two of, three of, four of, or five or more of outer shaft 616, camera, wall protection member 624, inner shaft 642, retention member shaft 646, or other components.

[0116] In some embodiments, the components of system 600 may be adapted such  
30 that the components are kept stationary by a friction fit and the movement of the mechanisms actuates one or more components and overcomes the friction fit. In some embodiments, the friction fit may be created in the fit between a mechanism and handle 612. In some embodiments, the friction fit may be created in a fit

between a gasket (e.g., a rubber gasket) and a mechanism or a shaft. In some embodiments, eversion mechanism 602 is held stationary by friction through a seal used for a wall protection member infusion port.

5 [0117] In some embodiments, the friction fit may be configured such that retention member mechanism 604 and retention member shaft 646 are stationary relative to eversion mechanism 602 and inner shaft 642 such that a user needs to control only one mechanism at a time. The friction may be such that the user's hand can provide enough force to overcome the friction and actuate retention member mechanism 604, but other movements, such as the movement of eversion mechanism 602 would not  
10 result in retention member 620 substantially moving relative to inner shaft 642. In this manner, the user would not need to continuously prevent movement of retention member mechanism 604 during actuation of eversion mechanism 602. In some embodiments, the components of system 600 may be held in positions by a lock, and the movement of the mechanisms disengages the lock and allows movement of one  
15 or more shafts.

[0118] In some embodiments, system 600 may be placed in an insertion configuration for inserting the distal end of the device into a lumen of a patient and navigating to a target site. In this configuration, eversion mechanism 602 and retention member mechanism 604 may be in particular positions. In an embodiment,  
20 eversion mechanism 602 may be in a distal-most position and retention member mechanism 604 may be in a proximal-most position. In this configuration of mechanisms 602, 604, retention member 620 may be positioned within inner shaft 642 such that retention member 620 is sheathed within inner shaft 642. In some embodiments, retention member 620 may be self-expanding and the confines of  
25 inner shaft 642 may prevent retention member 620 from expanding. The distal ends of outer shaft 616 and inner shaft 642 may be spaced apart such that wall protection member 624 is in an insertion configuration. For example, in configurations where wall protection member 624 is a balloon, the balloon may be deflated to facilitate insertion.

30 [0119] During a procedure, end effector 618 may be positioned near a target site (e.g., near a stone to be removed). In an embodiment, end effector 618 is positioned such that retention member 620 may capture a stone. For example, end effector 618 may be positioned such that the stone is between the distal end of inner shaft 642

and the distal end of wall protection member 624 (e.g., approximately within distance  $d$ ). System 600 may then be brought into a configuration for capturing a stone. To reach this configuration, retention member mechanism 604 may be actuated (e.g., moved distally) to advance stone retention member 620 out of inner shaft 642 and into an expanded configuration for capturing the stone. In addition, wall protection member 624 may be deployed (e.g., wall protection member 624 may be a balloon and may be expanded). From the configuration for capturing the stone, stone retention member 620 may be retracted to capture the stone. In some embodiments (e.g., where eversion of wall protection member 624 is decoupled from movement of stone retention member 620) a user may then actuate eversion mechanism 602 to cause eversion of wall protection member 624. In some embodiments (e.g., where interference between a captured stone and inner shaft 642 causes eversion), further retraction of stone retention member 620 causes eversion of wall protection member 624. The eversion of wall protection member 624 creates a pocket into which the stone may be drawn for ease of removal. In some embodiments, wall protection member 624 includes a balloon and eversion of wall protection member 624 causes deflation of the balloon. With the stone stowed in wall protection member 624, end effector 618 may then be removed from the lumen of the patient.

20 [0120] FIGS. 18A–18D illustrate an exemplary movement of shafts by articulating mechanisms 602, 604. In FIG. 18A, end effector 618 is positioned near a stone  $S$  to be captured. In FIG. 18B, a user actuates retention member mechanism 604 (e.g., by moving retention member mechanism 604 distally), which causes retention member 620 to advance distally out of inner shaft 642. Once advanced out of inner shaft 642, retention member 620 may be exposed and expanded. Retention member 620 may then capture stone  $S$ . For example, the user may retract retention member mechanism 604 to retract retention member 620 around stone  $S$ , capturing stone  $S$  in retention member 620. In FIG. 18C, wall protection member 624 is placed in an expanded configuration for receiving stone  $S$ . The user actuates retention member mechanism 604 to retract stone  $S$  towards wall protection member 624. In FIG. 18D, the user actuates eversion mechanism 602, causing wall protection member 624 to evert and form a pocket into which retention member 620 and stone  $S$  can be drawn (e.g., by further retraction of retention member mechanism 604). The user

may actuate eversion mechanism 602 by moving eversion mechanism 602 proximally. In some embodiments, wall protection member 624 may at least partially evert prior to stone *S* being drawn into the pocket (e.g. prior to stone being partially covered by wall protection member 624). With stone *S* captured and held  
5 in wall protection member 624, end effector 618 may be withdrawn from the lumen of the patient.

[0121] FIGS. 19A–19E illustrate an example movement of shafts by articulating retention member mechanism 604. In some embodiments, such as the one illustrated in FIGS. 19A–19E, system 600 may have a simplified handle actuation  
10 configuration such that actuation of retention member mechanism 604 alone may capture a stone *S* and evert wall protection member 624. In this embodiment, the axial force of stone retention member 620 containing a captured stone *S* on inner shaft 642 creates eversion force that may cause inner shaft 642 to move relative to outer shaft 616 causing wall protection member to evert. In this manner, the  
15 embodiment may have only a single mechanism with which the user interacts to capture the stone and evert wall protection member 624.

[0122] To evert wall protection member 624, retention member 620 may overcome the friction force in the proximal end created by a wall protection member seal. As a result, retention member shaft 646 may have a tendency to stretch rather  
20 than cause eversion if the axial stiffness of retention member shaft 646 is too low. In this embodiment, inner shaft 642 and retention member shaft 646 may be configured with sufficient stiffness to prevent substantial luminal stretching. One solution is to use a nitinol or stainless steel wire or hypotube for the retention member shaft 646. These shaft materials may have sufficient stiffness to induce  
25 eversion without stretching while also being flexible enough for deployment in tortuous anatomy. A nitinol or stainless steel wire with a diameter of at least 0.005” may have sufficient axial strength to prevent stretching, as does a stainless steel hypotube of at least 0.002” of wall thickness. These configurations of wire or hypotubes may be sufficient for typical working lengths of about 0.8 m to about 1.6  
30 m and other lengths.

[0123] In the embodiment illustrated in FIGS. 19A–19E, eversion mechanism 602 is located within handle 612 and does not have an external interface for direct actuation of the user. Actuation of retention member mechanism 604 directly or

indirectly causes physical interference with eversion mechanism 602, causing eversion mechanism 602 to move without direct actuation by user. In an example, the physical interference is directly between eversion mechanism 602 and retention member mechanism 604. In another example, interference between a captured stone and inner shaft 642 may cause movement of eversion mechanism 602. In some embodiments, there is a friction fit between eversion mechanism 602 and handle 612 to resist movement of eversion mechanism 602 and thereby resist eversion/eversion of wall protection member 624. The physical interference may need to overcome this friction before wall protection member 624 is everted.

10 [0124] In FIG. 19A, end effector 618 of system 600 is positioned near a stone *S* to be captured. FIG. 19B shows stone *S* captured in retention member 620. To capture stone *S*, a user may, for example, actuate stone retention member mechanism 604 (e.g., by moving retention member mechanism 604 distally, as indicated by the arrow), which causes retention member 620 to advance out of inner shaft 642. Then  
15 the retention member 620 may be used to capture stone *S*. A portion of retention member mechanism 604 abuts eversion mechanism 602 within the handle 612, preventing further distal movement of retention member mechanism 604. FIG. 19C shows wall protection member 624 in an expanded (e.g., inflated) configuration. The user actuates retention member mechanism 604 (e.g., by moving retention  
20 member mechanism 604 proximally, as indicated by the arrow) to move the captured stone *S* toward expanded wall protection member 624. In FIG. 19D, continued actuation of retention member mechanism 604 (e.g., proximally, as indicated by the dark arrow) causes movement of eversion mechanism 602 (e.g., proximally, as indicated by the light arrow). For example, the retraction of captured stone *S* may  
25 cause physical interference between stone *S* and inner shaft 642 and/or wall protection member 624, thereby causing eversion of wall protection member 624. In another example, retention member shaft 646 may be coupled to inner shaft 642, such that retraction of retention member shaft 646 with a captured stone causes retraction of inner shaft 642, thereby causing eversion of wall protection member  
30 624. In another example, the retraction of stone *S* causes movement of eversion mechanism 602, which causes eversion of wall protection member 624. The everted wall protection member 624 forms a pocket into which stone *S* may be captured and

held. With stone *S* captured and held in wall protection member 624, end effector 618 may be withdrawn from the lumen of the patient.

5 [0125] FIG. 19E illustrates an example un-eversion step. In particular, FIG. 19E shows un-eversion actuation (e.g., distal movement) of retention member mechanism 604 after stone *S* is captured in a partially everted wall protection member 624. In an example, this articulation may cause physical interference of fittings within handle 612, thereby causing wall protection member 624 to un-evert. In another example, this actuation may cause physical interference between retention member mechanism 604 and eversion mechanism 602, thereby causing wall protection member 624 to start to un-evert. Continued un-eversion actuation may cause stone retention member 620 to be advanced out of wall protection member 624. Such an un-eversion step may be used, for example, to repeat eversion for any reason. In another example, the un-eversion step may be performed after the device is removed from the patient in order to retrieve stone *S*.

15 [0126] Although this invention has been disclosed in the context of certain embodiments and examples, the present invention extends beyond the specifically disclosed embodiments to other alternative embodiments and/or uses of the invention and modifications and equivalents thereof. Thus, the foregoing description should not be interpreted as limiting the scope of the present invention as described by the following claims.

20

## CLAIMS

What is claimed is:

1. A system for removing a kidney stone from a ureter, the system comprising:  
5 an inner shaft extending coaxially within an outer shaft;  
a stone retention member shaft having a stone retention member and  
extending coaxially within the inner shaft;  
a wall protection member coupled to the outer shaft and the inner shaft; and  
a handle coupled with proximal ends of the outer shaft, the inner shaft, and  
10 the stone retention member shaft, the handle comprising:  
an eversion mechanism coupled to the inner shaft and configured to  
actuate the inner shaft, thereby everting the wall protection  
member to form a pocket adapted to receive a kidney stone;  
and  
15 a retention member mechanism coupled to the stone retention  
member shaft and configured to actuate the stone retention  
member shaft.
2. The system of claim 1, further comprising an elongate, flexible  
20 camera positioned coaxially within the stone retention member shaft, such that a  
distal end of the camera is located near a distal end of the inner shaft.
3. The system of claim 1, further comprising a guide wire extending  
coaxially within the stone retention member shaft.  
25
4. The system of claim 1, further comprising a laser fiber extending  
coaxially within the stone retention member shaft.
5. The system of claim 1, wherein the wall protection member  
30 comprises an expandable balloon and the handle further comprises a balloon  
infusion port configured to expand the balloon.

6. The system of claim 1, wherein the wall protection member is coupled to the inner shaft at an attachment point located on an outer circumference of the inner shaft, the attachment point proximally spaced from a distal tip of the inner shaft.

5

7. The system of claim 1, further comprising a friction fit adapted to resist movement of one of the inner shaft or the stone retention member shaft when the other shaft is actuated.

10 8. A system for removing a kidney stone from a ureter, the system comprising:

an inner shaft extending coaxially within an outer shaft;

a stone retention member shaft having a stone retention member and

extending coaxially within the inner shaft, the stone retention member

15 configured to capture a kidney stone;

a wall protection member coupled to the outer shaft and the inner shaft; and

a handle coupled with proximal ends of the outer shaft, the inner shaft, and

the stone retention member shaft, the handle comprising a retention

member mechanism coupled to the stone retention member shaft and

20 configured to move the stone retention member shaft,

wherein the wall protection member is configured to evert and form a pocket

responsive to axial force of proximal movement of the stone retention

member having a captured kidney stone.

25 9. The system of claim 8, wherein the stone retention member shaft comprises a solid shaft.

10. The system of claim 8, wherein the retention member mechanism is the only shaft articulation mechanism that the handle comprises.

30

11. The system of claim 8, wherein the system is configured to capture a kidney stone in the stone retention member, retract the stone retention member, and evert the wall protection member using the retention member mechanism.

12. The system of claim 8, wherein the wall protection member is coupled to the inner shaft at an attachment point located on an outer circumference of the inner shaft, the attachment point proximally spaced from a distal tip of the inner shaft.

5

13. The system of claim 8, wherein the stone retention member shaft has sufficient axial stiffness to cause eversion of the wall protection member without the stone retention member shaft substantially stretching.

10

14. The system of claim 13, wherein the stone retention member shaft having sufficient axial stiffness comprises a stainless steel or nitinol wire having a diameter of at least 0.005" or a stainless steel hypotube having a wall thickness of 0.002".

15

15. The system of claim 8, wherein the wall protection member is an expandable balloon and the handle further comprises a balloon infusion port configured to expand the balloon.

20

16. The system of claim 8, further comprising an eversion mechanism disposed within the handle.

17. A method for removing a kidney stone from a ureter, the method comprising:

25

advancing a distal end of an elongate, flexible kidney stone removal device into the ureter to a location near the kidney stone;

advancing, using a retention member mechanism at a handle of the device, a shaft of an expandable stone retention member through an inner shaft of the device to expose an expandable, stone retention portion of the stone retention member out of a distal end of the inner shaft;

30

trapping the kidney stone in the stone retention portion of the stone retention member;

everting a portion of the wall protection member to form a pocket;

retracting, using the retention member mechanism, the retention portion having the trapped kidney stone into the pocket; and

removing the kidney stone removal device from the ureter while the stone retention member and the kidney stone are at least partially within the pocket.

5           **18.**     The method of claim 17, wherein the wall protection member everting and forming a pocket is caused by the retraction of the retention portion.

**19.**     The method of claim 17, wherein the retention member mechanism is the only mechanism for actuating the shafts of the kidney stone removal device.

10

**20.**     The method of claim 17, wherein the wall protection member comprises an inflatable balloon, and the handle of the device comprises a port configured to inflate the balloon.

15           **21.**     The method of claim 20, further comprising inflating the balloon, wherein the balloon partially deflates responsive to a portion of the wall protection member everting.

20           **22.**     The method of claim 20, further comprising dilating a portion of the ureter by inflating the balloon.

**23.**     The method of claim 17, wherein everting a portion of the wall protection member to form a pocket comprises articulating a protection member mechanism to move an inner shaft coupled to the wall protection member.

25

**24.**     The method of claim 17, further comprising advancing a distal end of the elongate, flexible kidney stone removal device into a lumen of a ureteroscope.

30           **25.**     The method of claim 17, wherein everting the portion of the wall protection member to form a pocket is caused, in part, by physical interference between the trapped kidney stone and the inner shaft.

**26.**     The method of claim 17, further comprising uneverting the everted portion of the wall protection member, wherein the uneverting is caused, in part, by

35

physical interference between fittings within a handle of the flexible kidney stone removal device.

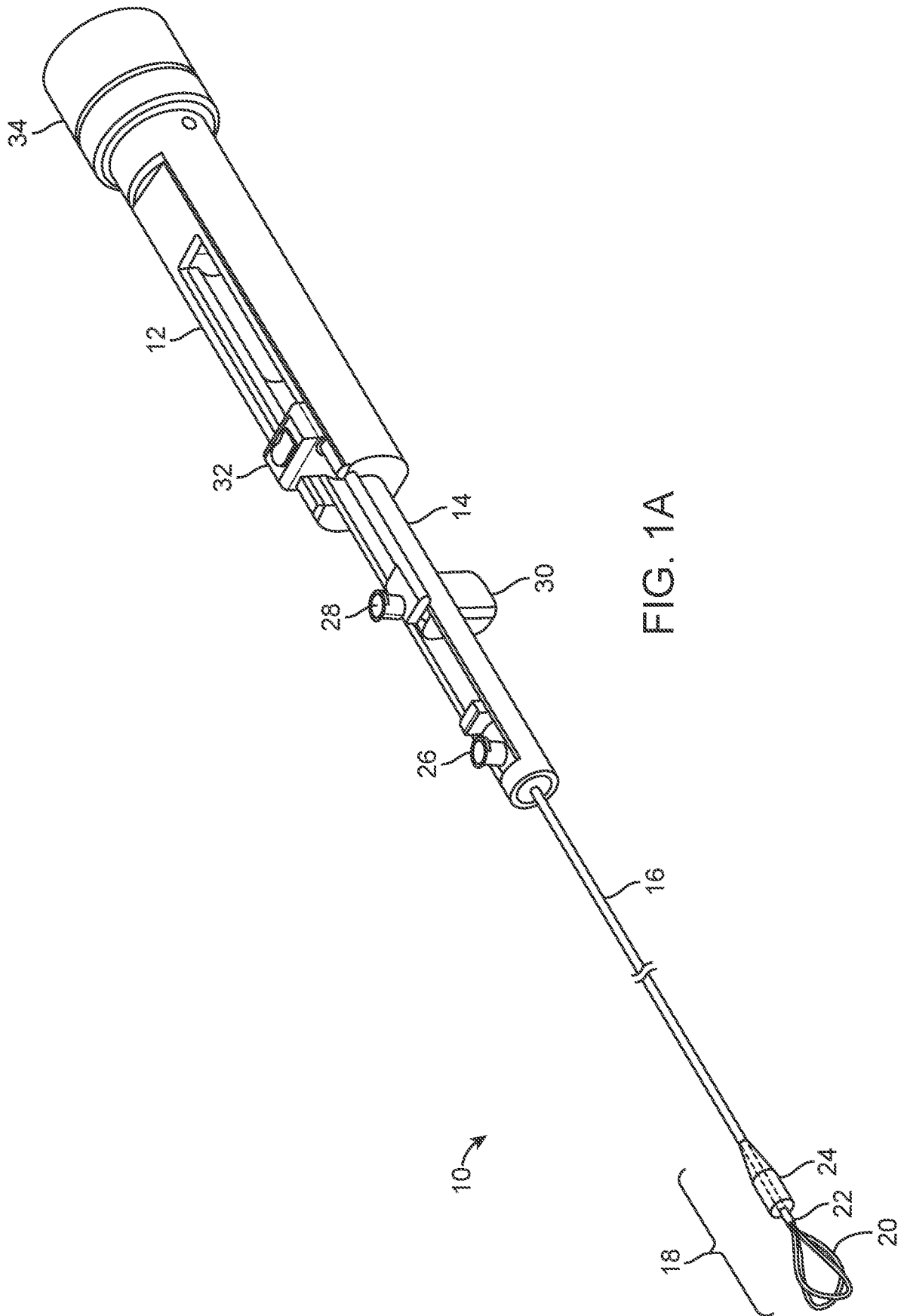

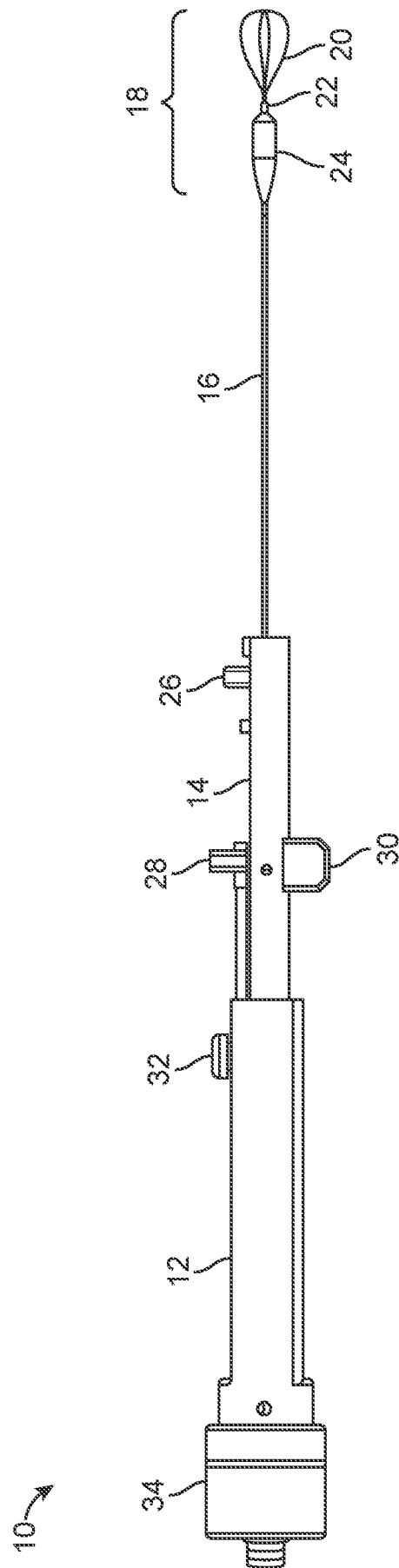

FIG. 1B

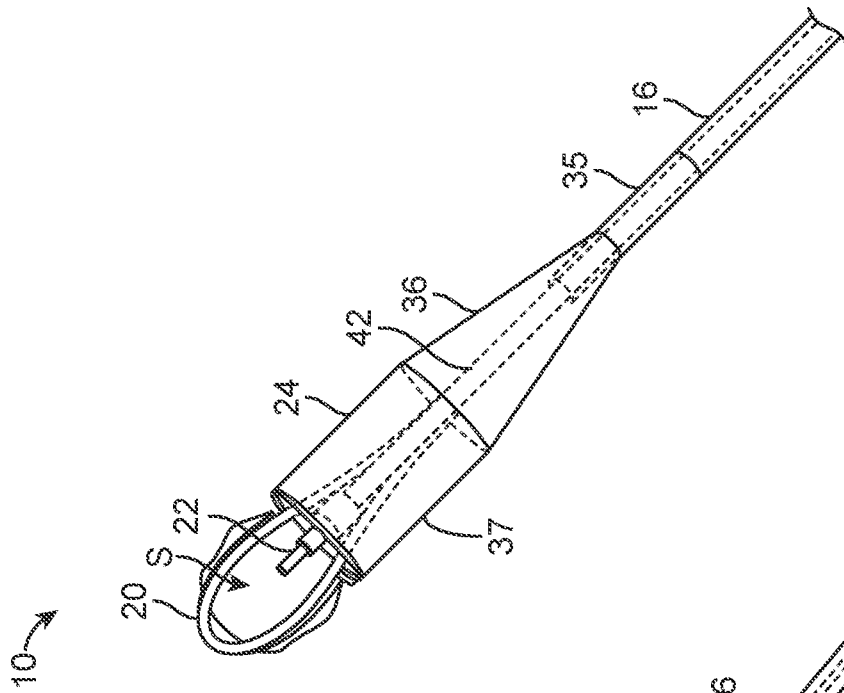

FIG. 2A

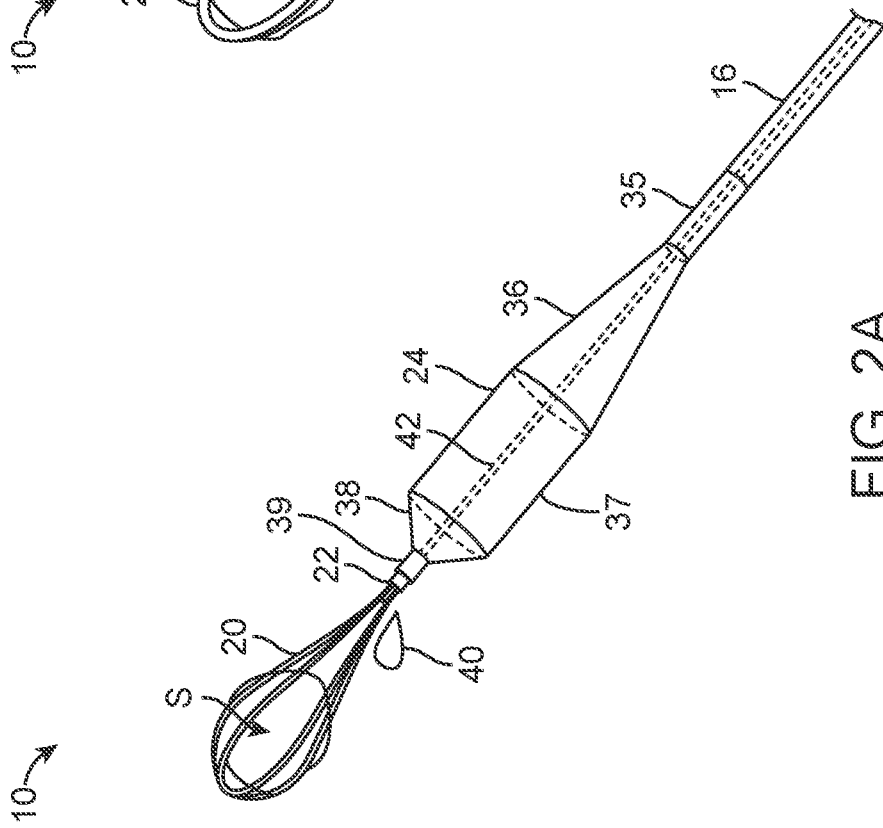

FIG. 2B

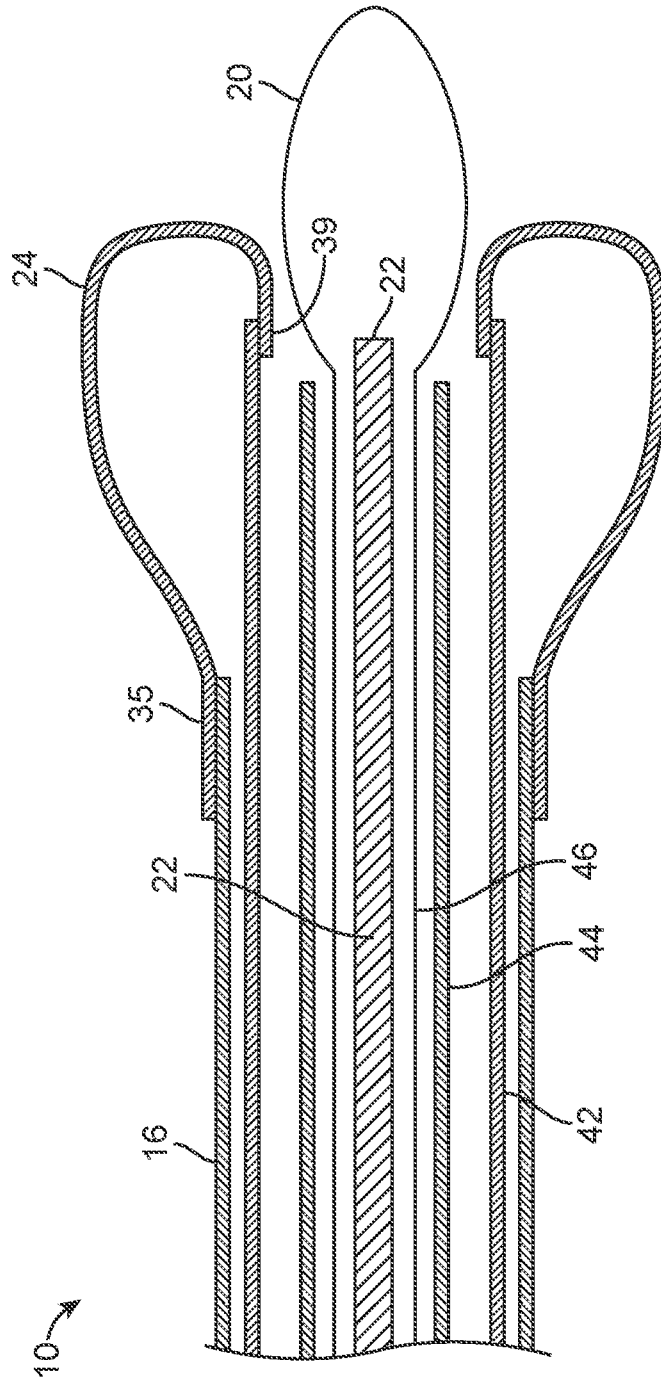

FIG. 3A

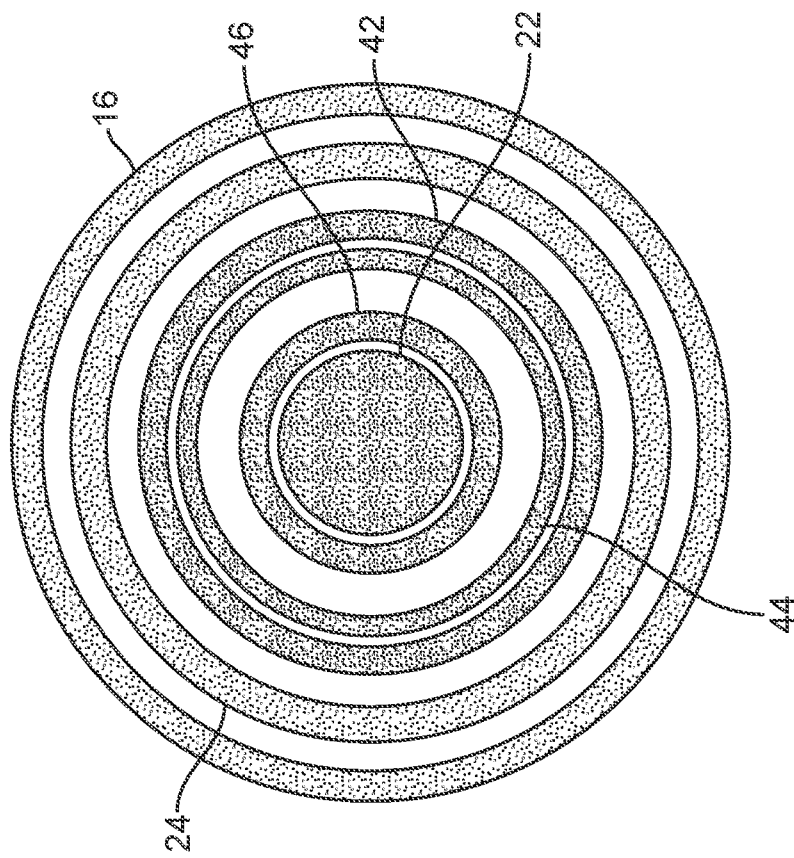
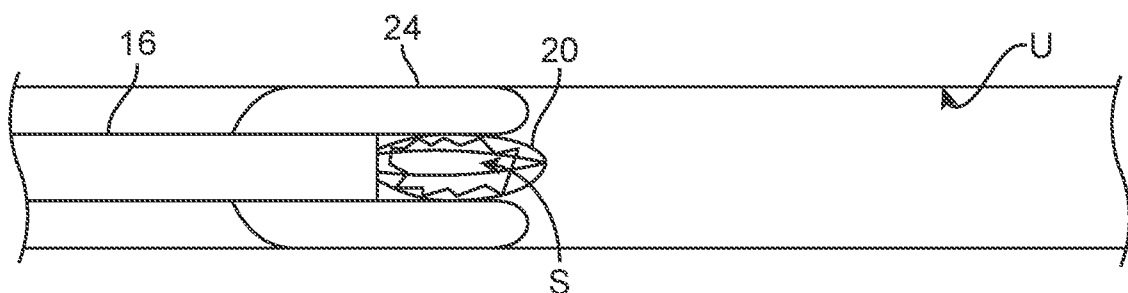
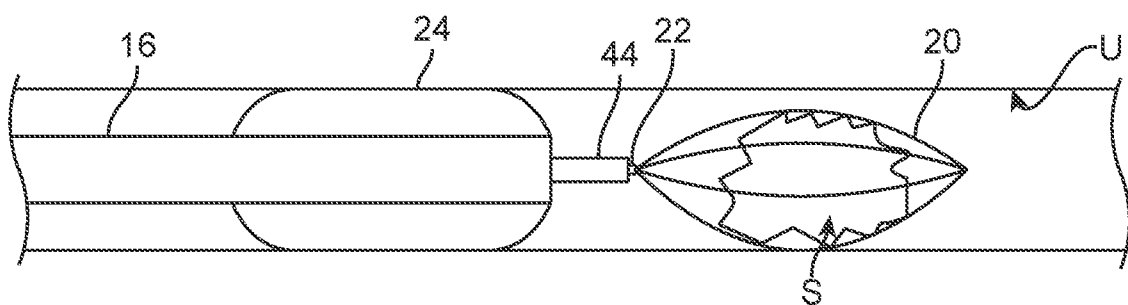
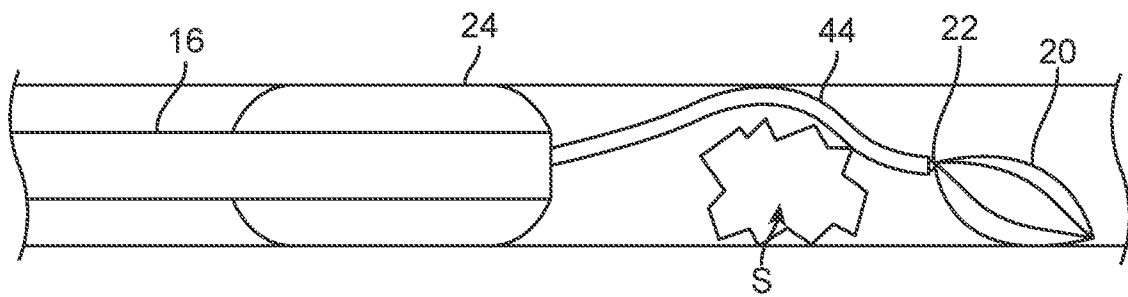
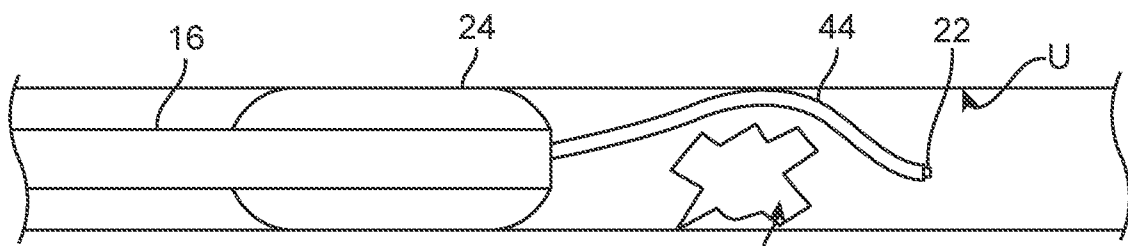
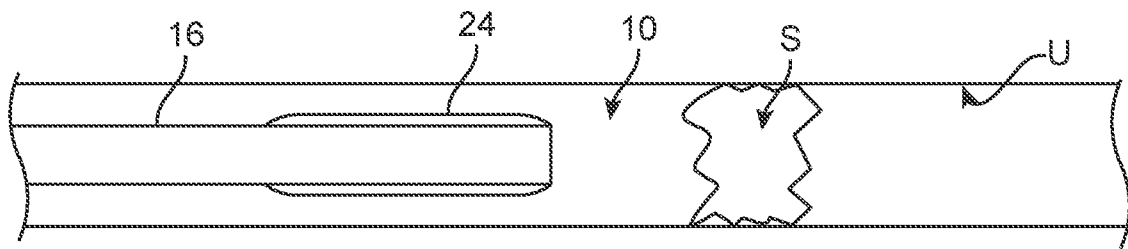

FIG. 3B



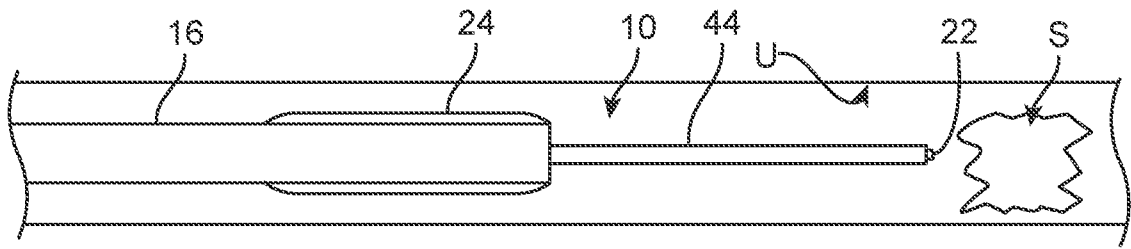

FIG. 5A

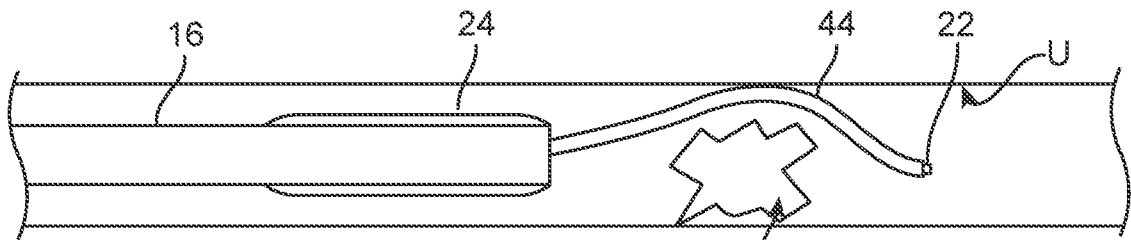

FIG. 5B

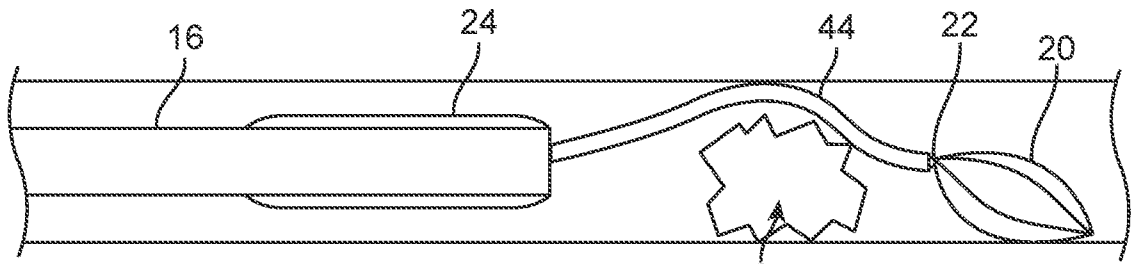

FIG. 5C

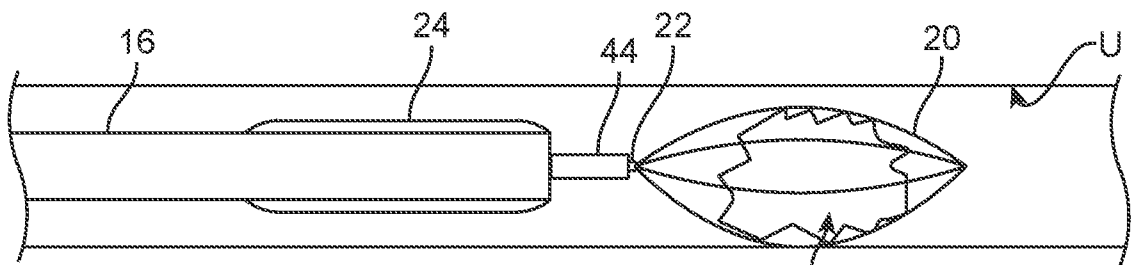

FIG. 5D

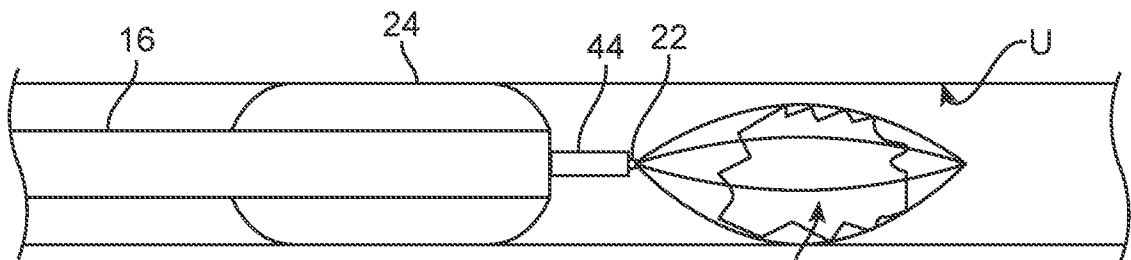

FIG. 5E

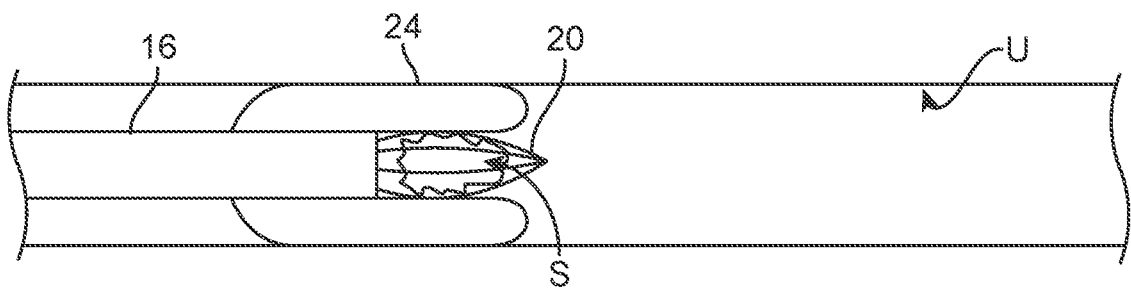

FIG. 5F

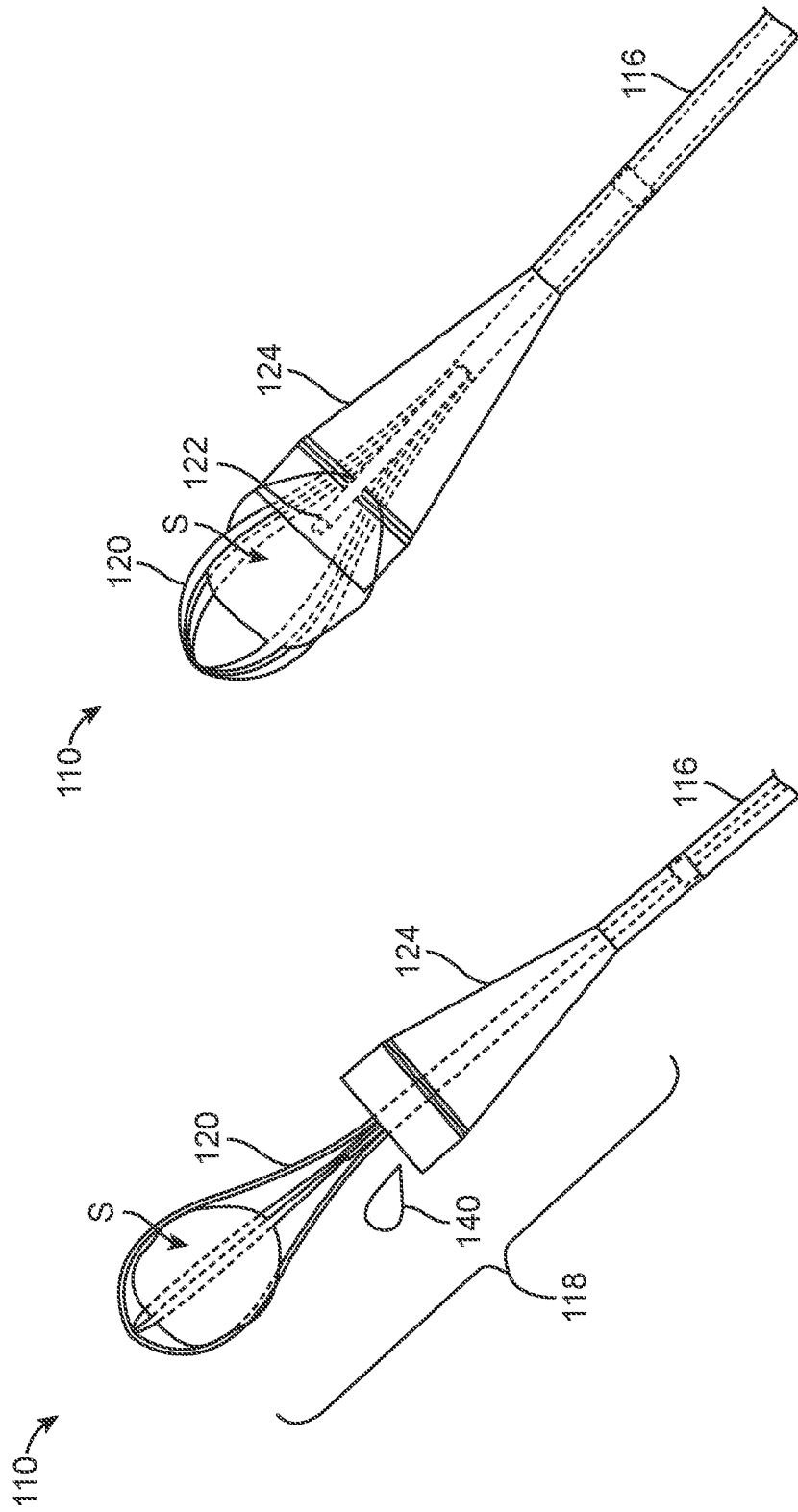

FIG. 6B

FIG. 6A

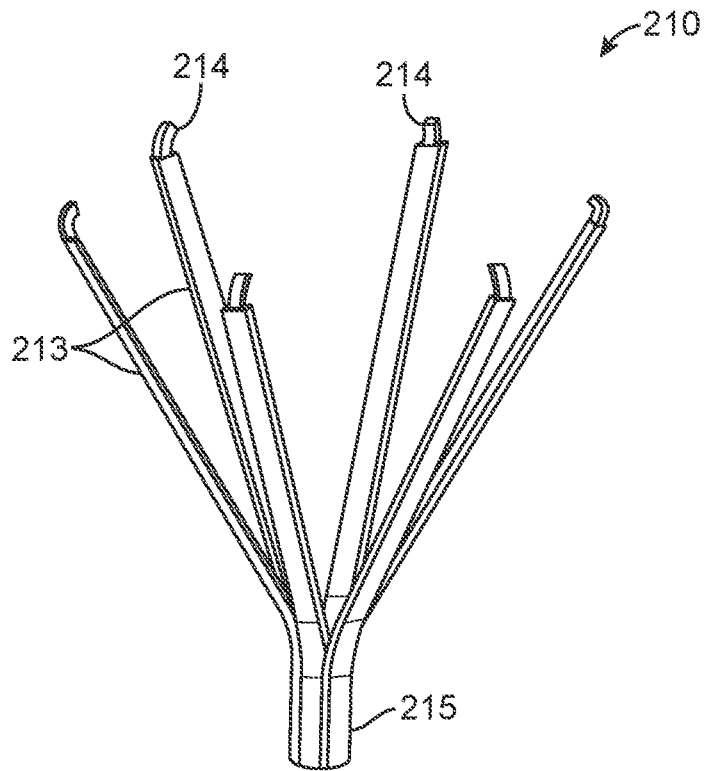

FIG. 7A

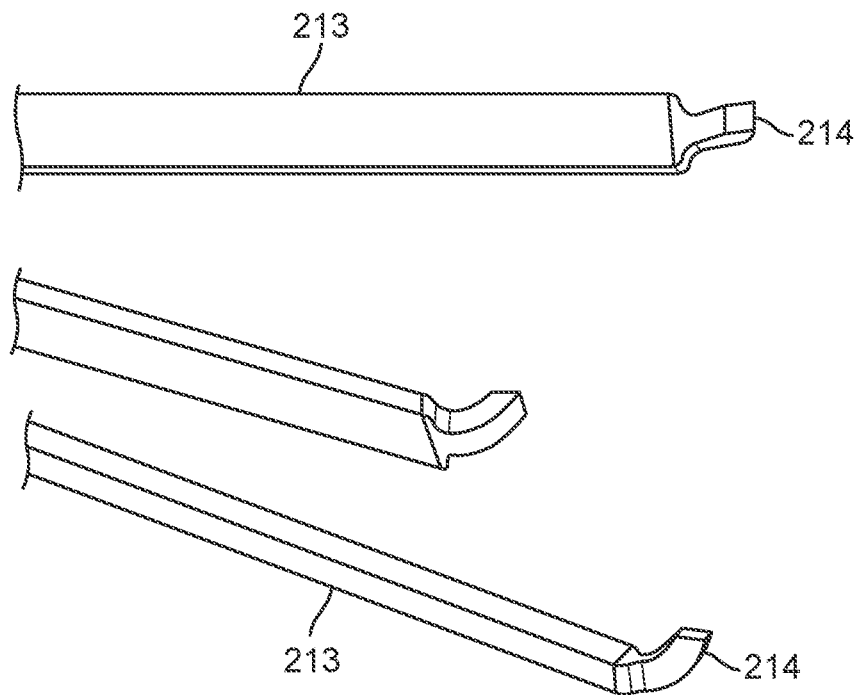

FIG. 7B

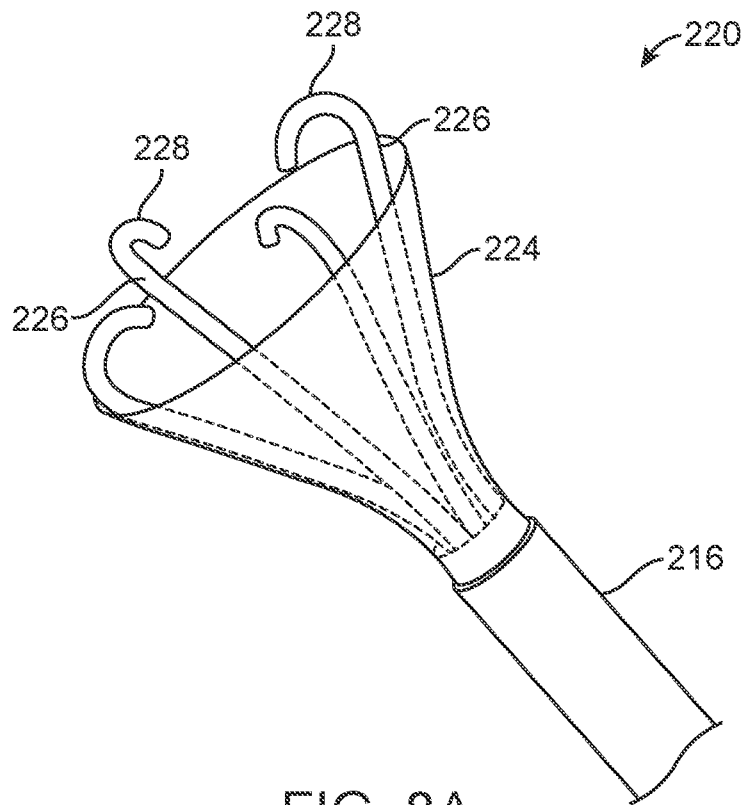

FIG. 8A

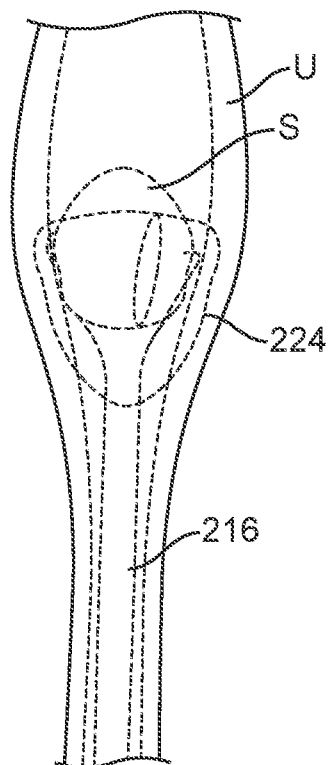

FIG. 8B

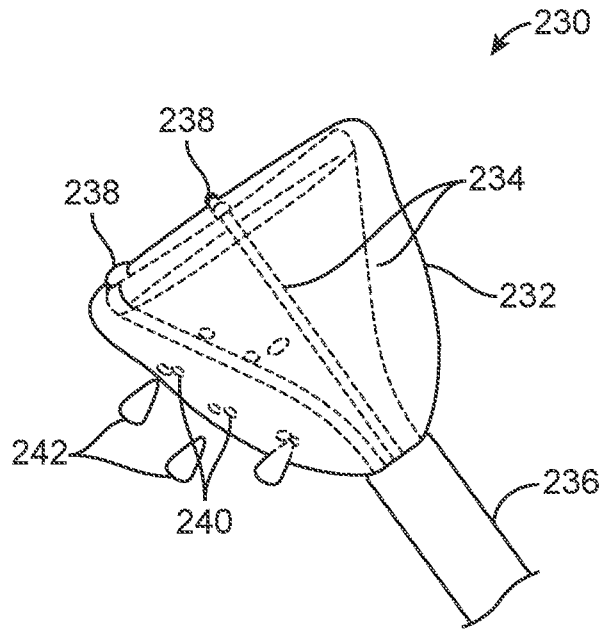

FIG. 9

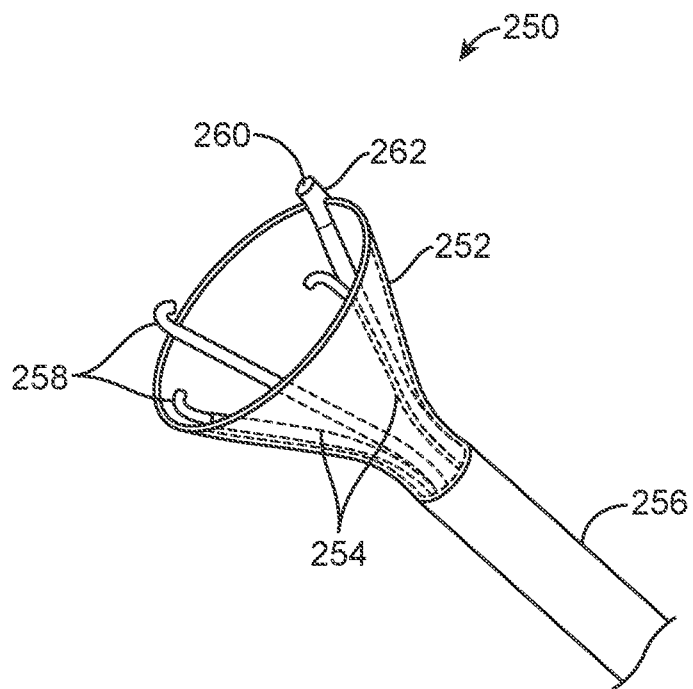

FIG. 10

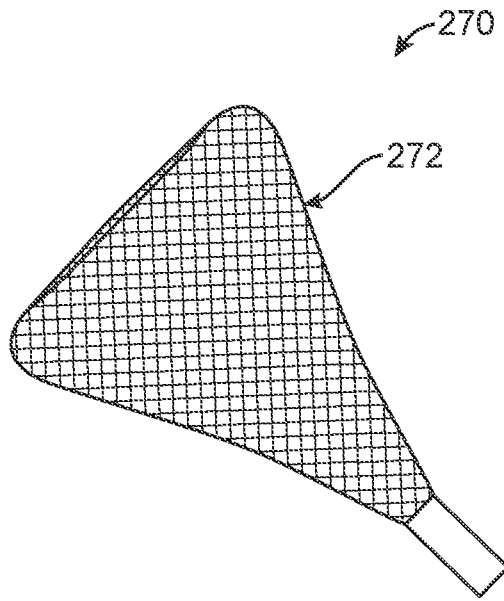

FIG. 11A

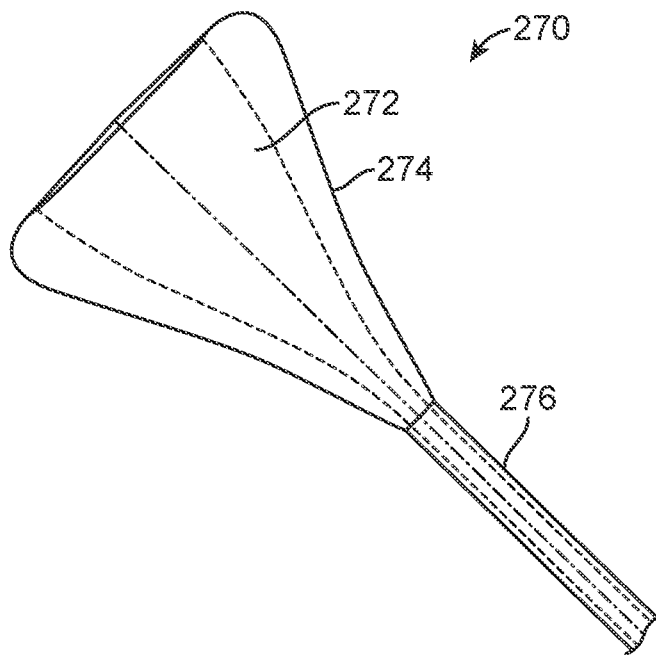

FIG. 11B

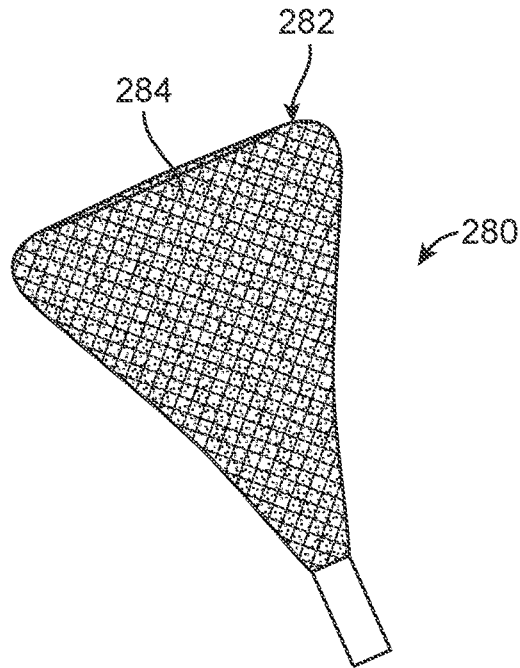

FIG. 12

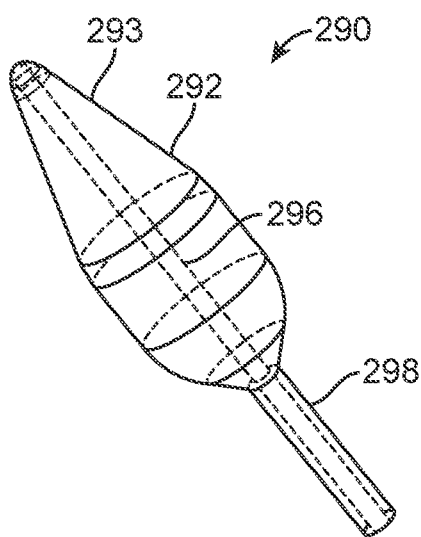

FIG. 13A

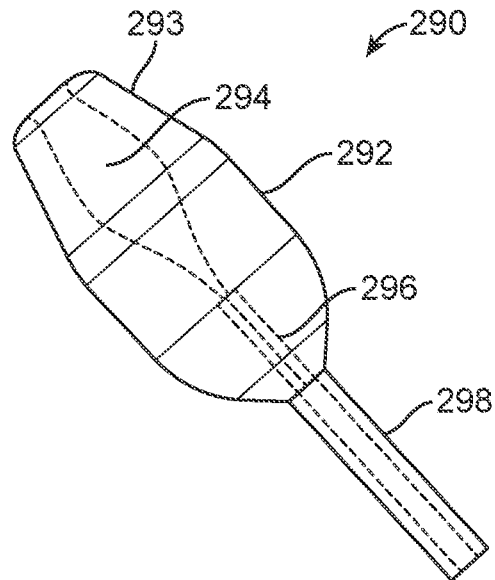

FIG. 13B

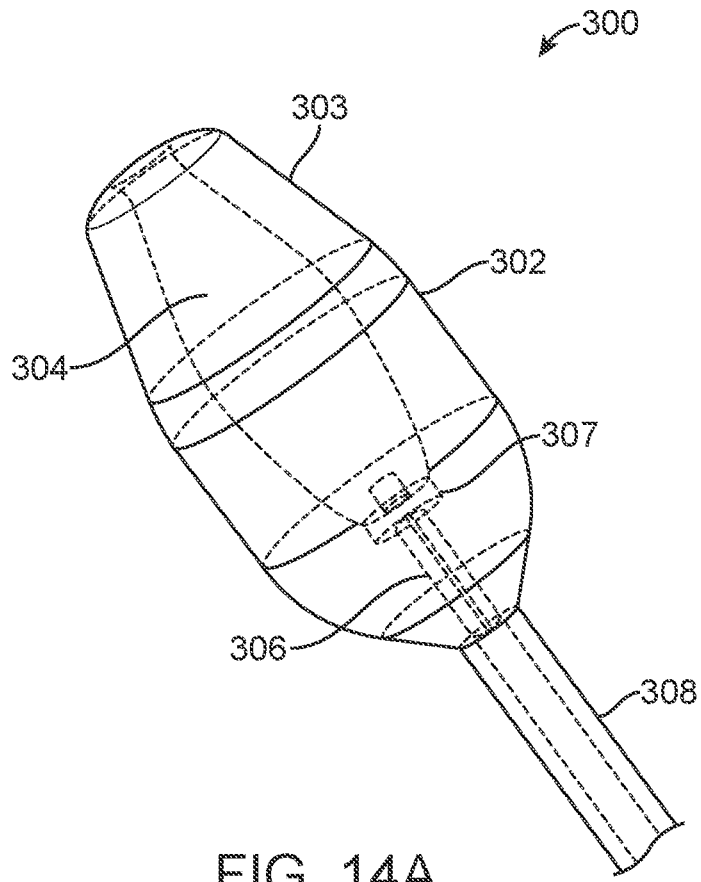

FIG. 14A

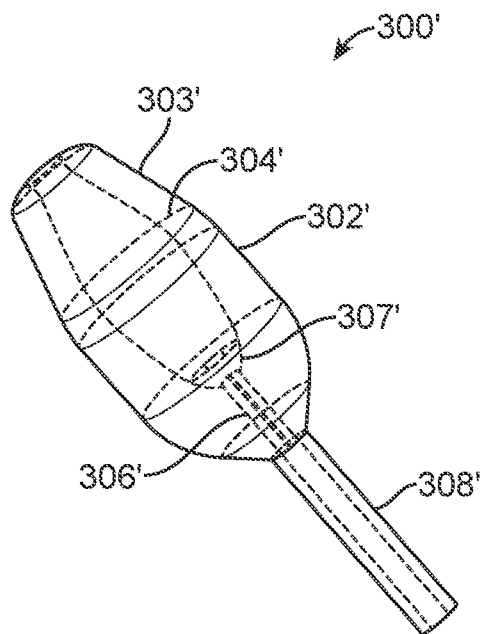

FIG. 14B

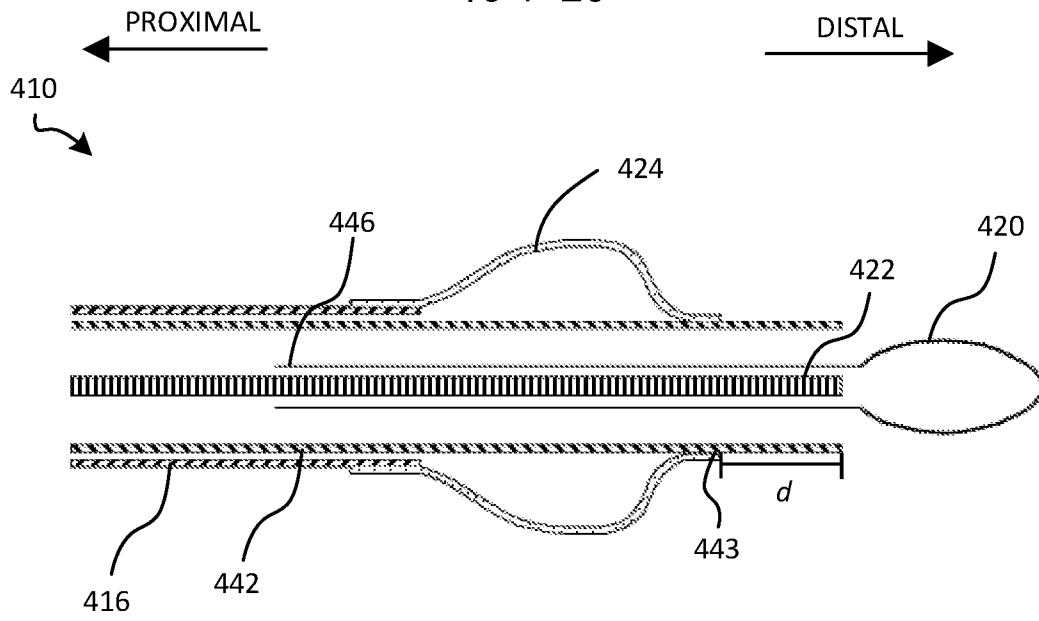

FIG. 15A

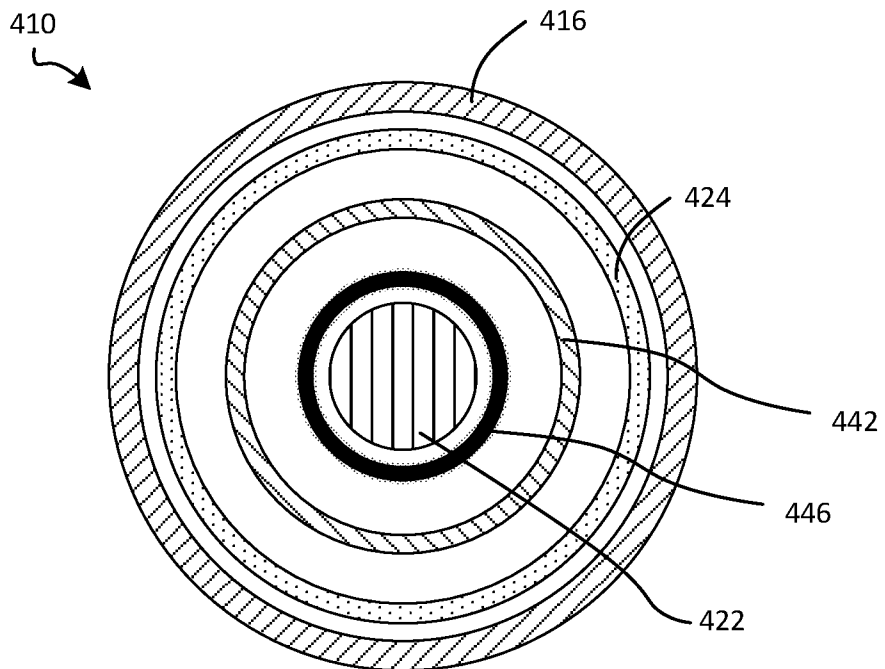

FIG. 15B

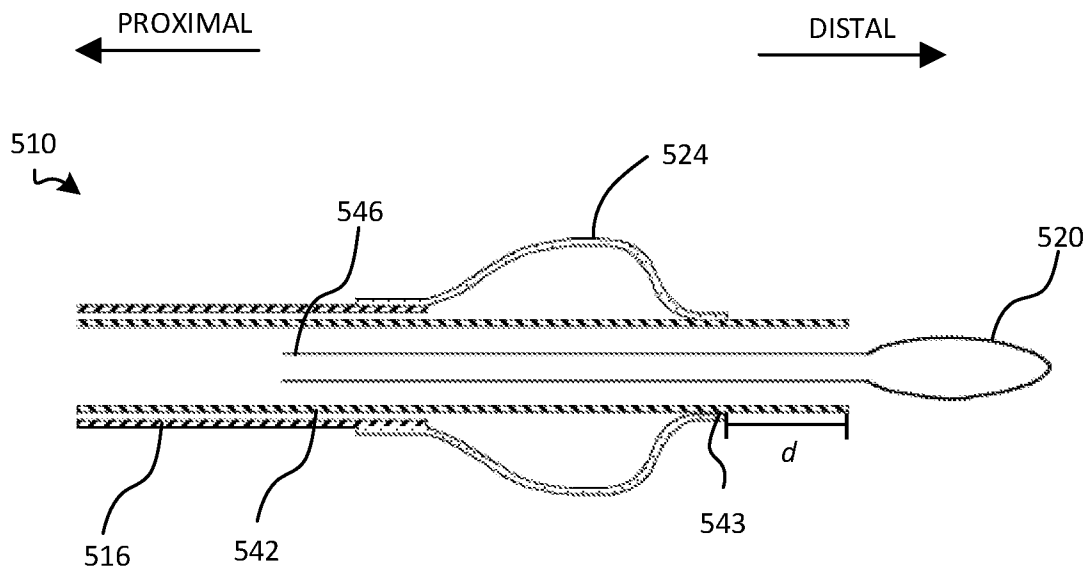

FIG. 16A

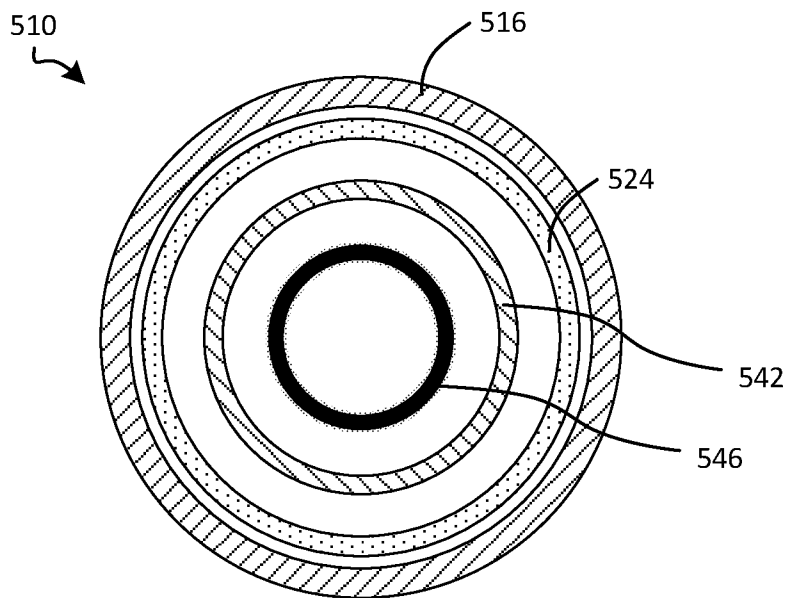

FIG. 16B

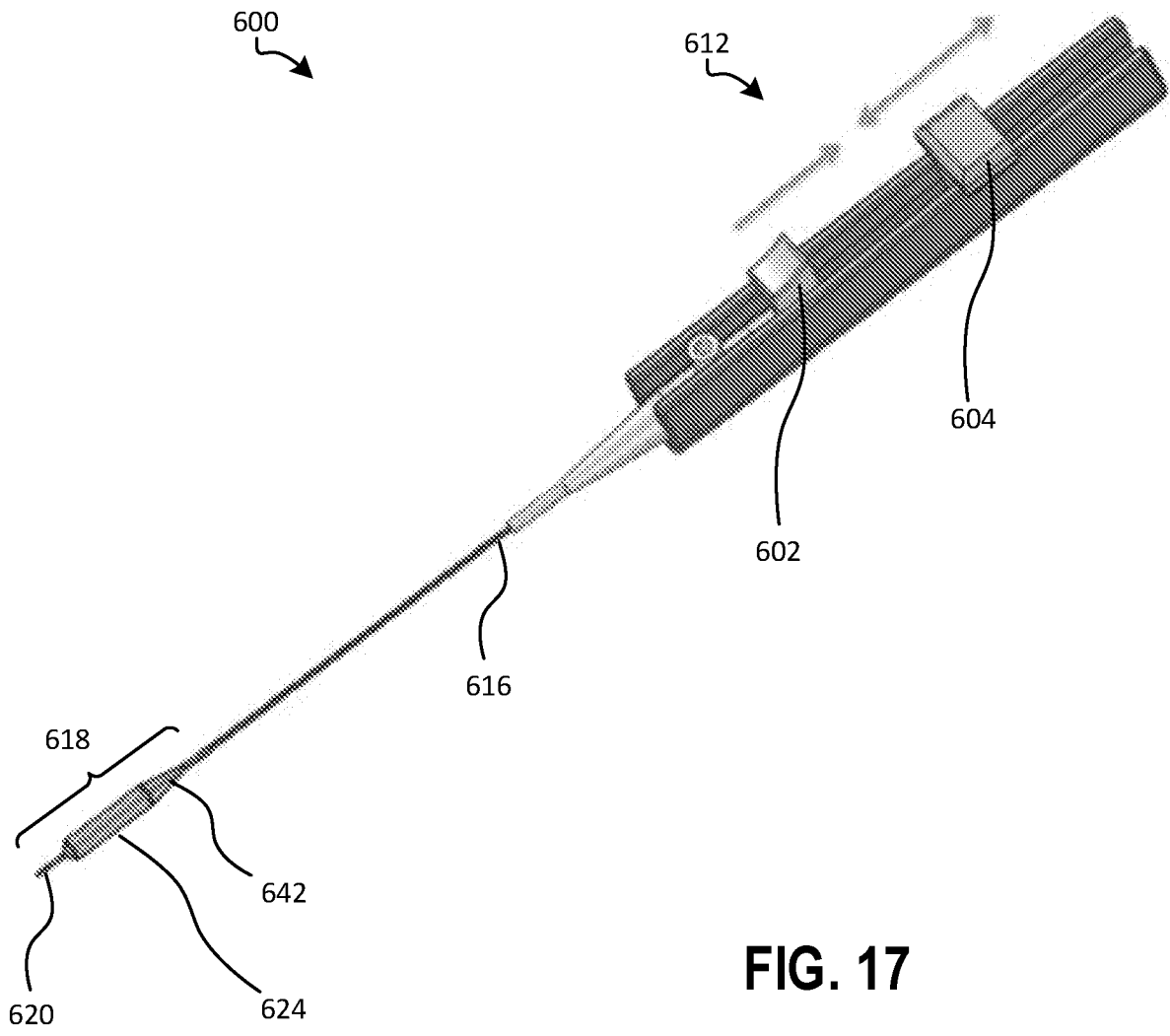
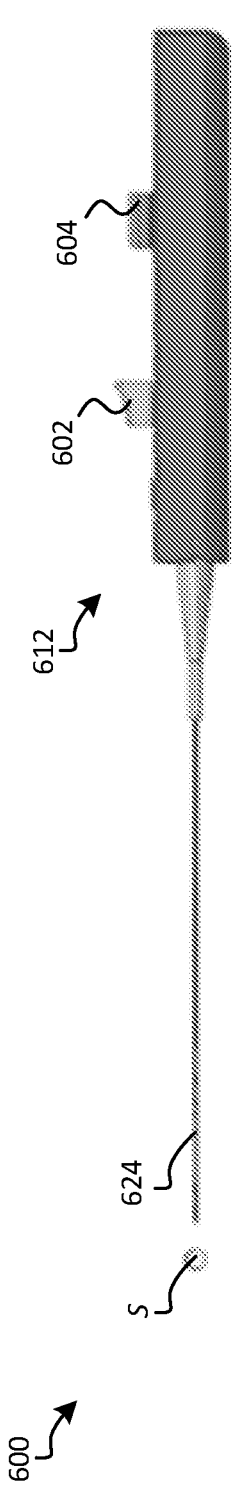
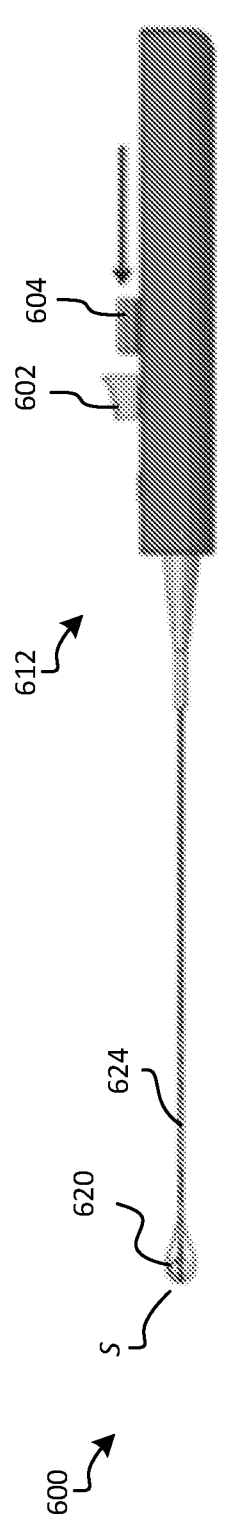

FIG. 17

**FIG. 18A**



**FIG. 18B**



**FIG. 18C**

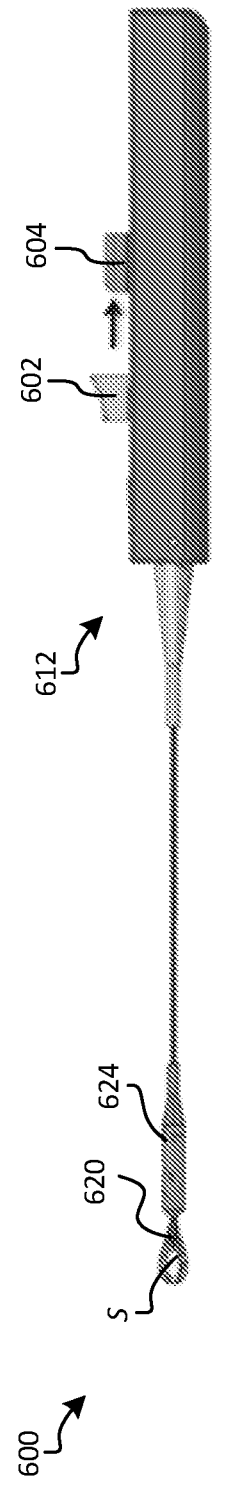

**FIG. 18D**

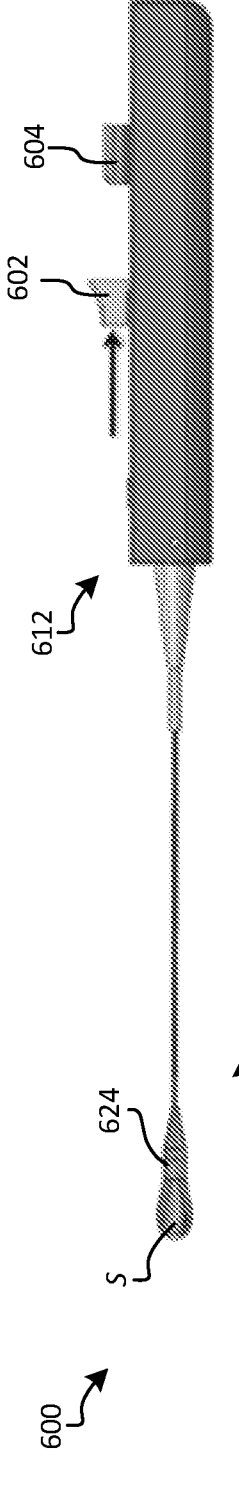

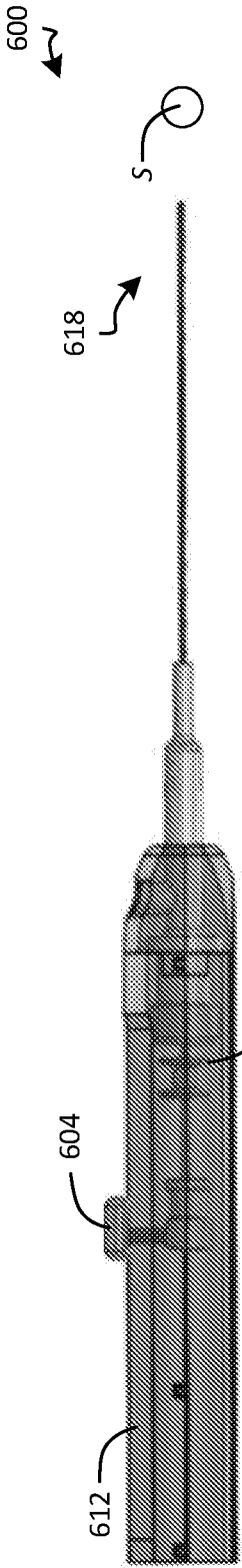

FIG. 19A

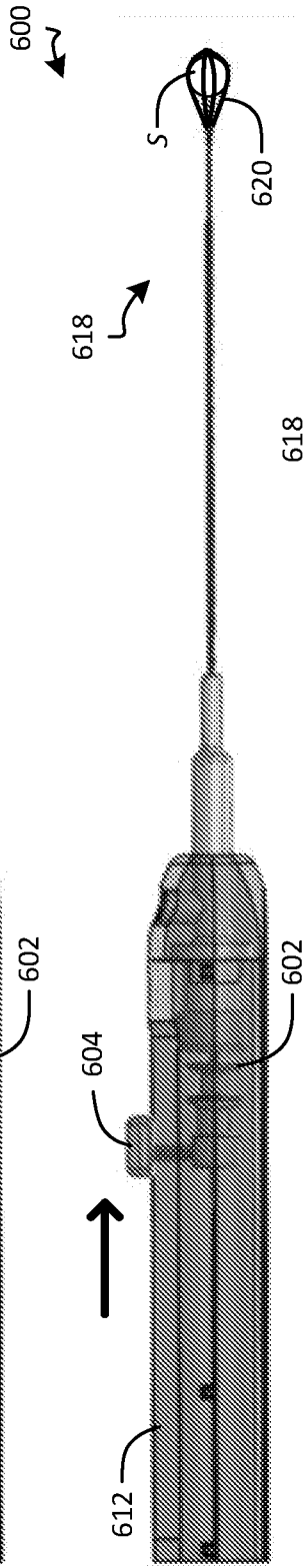

FIG. 19B

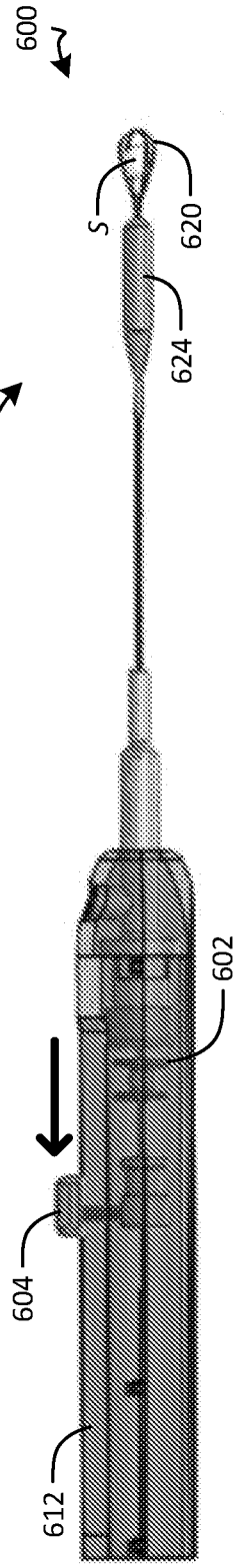

FIG. 19C

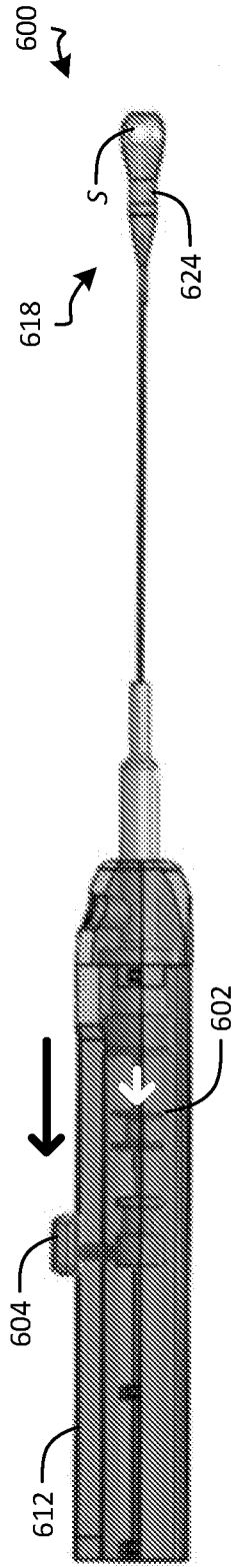

FIG. 19D

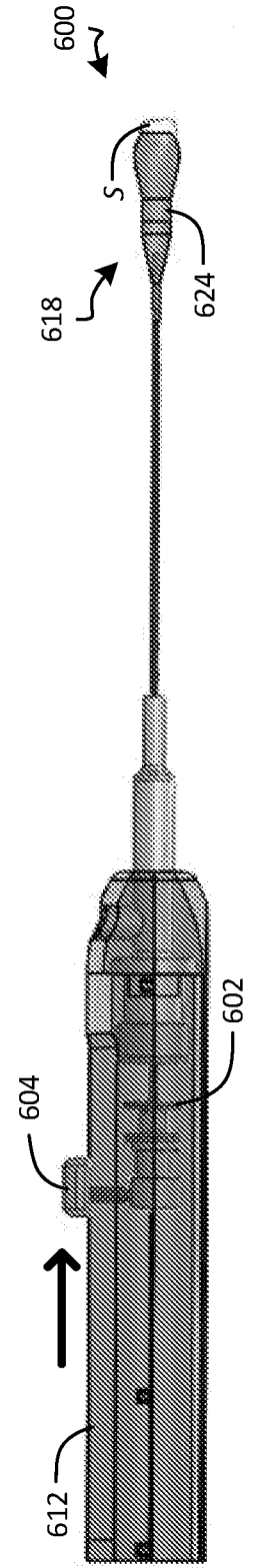

FIG. 19E

# INTERNATIONAL SEARCH REPORT

International application No.  
PCT/US2017/029914

## Box No. II Observations where certain claims were found unsearchable (Continuation of item 2 of first sheet)

This international search report has not been established in respect of certain claims under Article 17(2)(a) for the following reasons:

1.  Claims Nos.: **17-26**  
because they relate to subject matter not required to be searched by this Authority, namely:  
**see FURTHER INFORMATION sheet PCT/ISA/210**
  
2.  Claims Nos.:  
because they relate to parts of the international application that do not comply with the prescribed requirements to such an extent that no meaningful international search can be carried out, specifically:
  
3.  Claims Nos.:  
because they are dependent claims and are not drafted in accordance with the second and third sentences of Rule 6.4(a).

## Box No. III Observations where unity of invention is lacking (Continuation of item 3 of first sheet)

This International Searching Authority found multiple inventions in this international application, as follows:

1.  As all required additional search fees were timely paid by the applicant, this international search report covers all searchable claims.
  
2.  As all searchable claims could be searched without effort justifying an additional fees, this Authority did not invite payment of additional fees.
  
3.  As only some of the required additional search fees were timely paid by the applicant, this international search report covers only those claims for which fees were paid, specifically claims Nos.:
  
4.  No required additional search fees were timely paid by the applicant. Consequently, this international search report is restricted to the invention first mentioned in the claims; it is covered by claims Nos.:

### Remark on Protest

- The additional search fees were accompanied by the applicant's protest and, where applicable, the payment of a protest fee.
- The additional search fees were accompanied by the applicant's protest but the applicable protest fee was not paid within the time limit specified in the invitation.
- No protest accompanied the payment of additional search fees.

**INTERNATIONAL SEARCH REPORT**

International application No  
PCT/US2017/029914

A. CLASSIFICATION OF SUBJECT MATTER  
INV. A61B18/26 A61B17/22 A61B17/221 A61B90/00  
ADD.  
According to International Patent Classification (IPC) or to both national classification and IPC

B. FIELDS SEARCHED  
Minimum documentation searched (classification system followed by classification symbols)  
A61B A61M

Documentation searched other than minimum documentation to the extent that such documents are included in the fields searched

Electronic data base consulted during the international search (name of data base and, where practicable, search terms used)  
EPO-Internal

C. DOCUMENTS CONSIDERED TO BE RELEVANT

Category*	Citation of document, with indication, where appropriate, of the relevant passages	Relevant to claim No.
X	US 2014/309655 A1 (GAL DAVID [US] ET AL) 16 October 2014 (2014-10-16)	1,2,5-16
Y	paragraphs [0051], [0062]; figures 1b,2a,2b,3a	3,4
Y	----- US 2009/287193 A1 (DESAI RUPESH [US] ET AL) 19 November 2009 (2009-11-19)	3,4
	paragraphs [0011], [0035]	
A	----- US 2007/038227 A1 (MASSICOTTE J M [US] ET AL) 15 February 2007 (2007-02-15)	1-16
	paragraphs [0008], [0012], [0039]	
A	----- US 2008/188866 A1 (KARPIEL JOHN A [US] ET AL) 7 August 2008 (2008-08-07)	1-16
	paragraphs [0041], [0050]	
	-----	

Further documents are listed in the continuation of Box C.

See patent family annex.

\* Special categories of cited documents :

"A" document defining the general state of the art which is not considered to be of particular relevance

"E" earlier application or patent but published on or after the international filing date

"L" document which may throw doubts on priority claim(s) or which is cited to establish the publication date of another citation or other special reason (as specified)

"O" document referring to an oral disclosure, use, exhibition or other means

"P" document published prior to the international filing date but later than the priority date claimed

"T" later document published after the international filing date or priority date and not in conflict with the application but cited to understand the principle or theory underlying the invention

"X" document of particular relevance; the claimed invention cannot be considered novel or cannot be considered to involve an inventive step when the document is taken alone

"Y" document of particular relevance; the claimed invention cannot be considered to involve an inventive step when the document is combined with one or more other such documents, such combination being obvious to a person skilled in the art

"&" document member of the same patent family

Date of the actual completion of the international search <b>27 June 2017</b>	Date of mailing of the international search report <b>05/07/2017</b>
--	---

Name and mailing address of the ISA/ European Patent Office, P.B. 5818 Patentlaan 2 NL - 2280 HV Rijswijk Tel. (+31-70) 340-2040, Fax: (+31-70) 340-3016	Authorized officer <b>Lee, Ronan</b>
--	---

# INTERNATIONAL SEARCH REPORT

Information on patent family members

International application No PCT/US2017/029914
---

Patent document cited in search report	Publication date	Patent family member(s)	Publication date
US 2014309655	A1	16-10-2014	CN 105307582 A
			EP 2986237 A1
			JP 2016515464 A
			US 2014309655 A1
			US 2014309656 A1
			US 2015133948 A1
			US 2016106447 A1
			WO 2014172412 A1
-----			
US 2009287193	A1	19-11-2009	NONE
-----			
US 2007038227	A1	15-02-2007	US 2007038227 A1
			US 2013096571 A1
			WO 2007022055 A1
-----			
US 2008188866	A1	07-08-2008	EP 2120736 A1
			US 2008188866 A1
			WO 2008097833 A1
-----			

**FURTHER INFORMATION CONTINUED FROM PCT/ISA/ 210**

Continuation of Box II.1

Claims Nos.: 17-26

The subject-matter of claims 17-26 appears to constitute a surgical procedure on the human body, and therefore under Rule 39.1(iv) PCT (Method for treatment of the human or animal body by surgery), these claims have not been searched. For the same reason, the claims do not require preliminary examination, Rule 67.1 (iv) PCT.

专利名称(译)	篮子和外翻气球与简化的设计和控制		
公开(公告)号	<a href="#">EP3448295A1</a>	公开(公告)日	2019-03-06
申请号	EP2017722619	申请日	2017-04-27
[标]申请(专利权)人(译)	计算器技术股份有限公司		
申请(专利权)人(译)	CALCULA TECHNOLOGIES , INC.		
当前申请(专利权)人(译)	CALCULA TECHNOLOGIES , INC.		
[标]发明人	BONNEAU RAYMOND ARTHUR GAL DAVID		
发明人	BONNEAU, RAYMOND, ARTHUR GAL, DAVID		
IPC分类号	A61B18/26 A61B17/22 A61B17/221 A61B90/00		
优先权	15/141458 2016-04-28 US		
外部链接	<a href="#">Espacenet</a>		

#### 摘要(译)

所公开的系统，方法和装置可包括用于从输尿管移除肾结石的系统。该系统可具有在外轴内同轴延伸的内轴，具有石材保持构件并在内轴内同轴延伸的石材保持构件轴，连接到外轴和内轴的壁保护构件，以及连接的手柄具有外轴的近端，内轴和石头保持构件轴。手柄可以包括外翻机构，该外翻机构连接到内轴并且构造成致动内轴，从而外翻壁保护构件以形成适于接收肾结石的口袋。该系统还可包括保持构件机构，该保持构件机构联接到石材保持构件轴并且构造成致动石材保持构件轴。