

(19) World Intellectual Property Organization  
International Bureau



(43) International Publication Date  
30 July 2009 (30.07.2009)

PCT

(10) International Publication Number  
**WO 2009/094476 A1**

(51) International Patent Classification:  
A61M 5/14 (2006.01)

(21) International Application Number:  
PCT/US2009/031724

(22) International Filing Date: 22 January 2009 (22.01.2009)

(25) Filing Language: English

(26) Publication Language: English

(30) Priority Data:  
61/022,772 22 January 2008 (22.01.2008) US  
61/104,963 13 October 2008 (13.10.2008) US

(71) Applicant (for all designated States except US): **APPLIED MEDICAL RESOURCES CORPORATION** [US/US]; 22872 Avenida Empresa, Rancho Santa Margarita, CA 92688 (US).

(72) Inventors; and

(75) Inventors/Applicants (for US only): **ALBRECHT,**

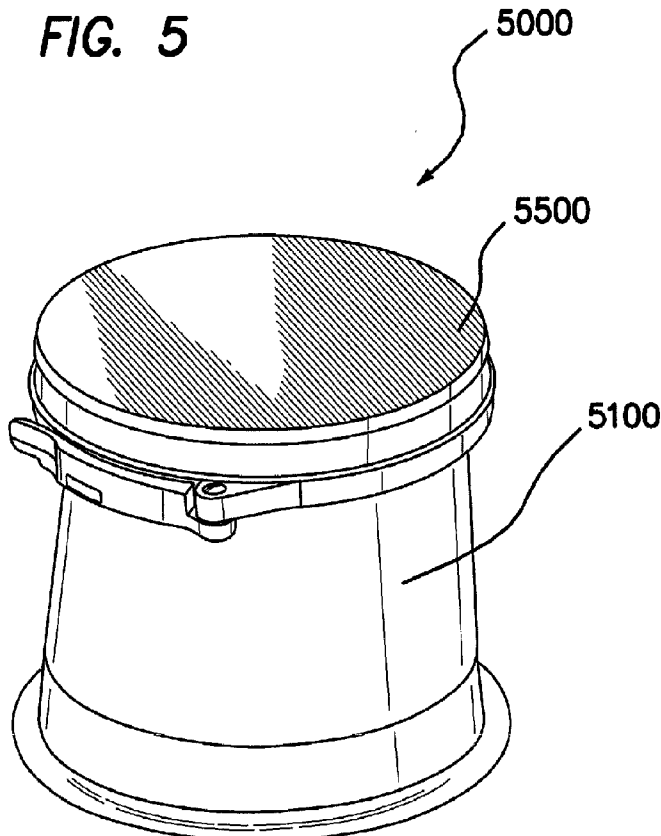
**Jeremy, J.** [US/US]; 20 Half Moon Trail, Ladera Ranch, CA 92694 (US). **LECHUGA, Juan, J.** [US/US]; 2033 W. Chandler Ave, Santa Ana, CA 92704 (US). **BECERRA, Matthew, M.** [US/US]; 53 Anacapa Ct., Foothill Ranch, CA 92610 (US). **GADBERRY, Donald, L.** [US/US]; 381 Calle Guaymas, San Clemente, CA 92672 (US). **JOHNSON, Gary, M.** [US/US]; 24662 Canela, Mission Viejo, CA 92692 (US). **BRUSTAD, John, R.** [US/US]; 34056 Formosa Drive, Dana Point, CA 92629 (US).

(74) Agent: **HO, Pui, Tong**; 2287 Avenida Empresa, Rancho Santa Margarita, CA 92688 (US).

(81) Designated States (unless otherwise indicated, for every kind of national protection available): AE, AG, AL, AM, AO, AT, AU, AZ, BA, BB, BG, BH, BR, BW, BY, BZ, CA, CH, CN, CO, CR, CU, CZ, DE, DK, DM, DO, DZ, EC, EE, EG, ES, FI, GB, GD, GE, GH, GM, GT, HN, HR, HU, ID, IL, IN, IS, JP, KE, KG, KM, KN, KP, KR, KZ, LA, LC, LK, LR, LS, LT, LU, LY, MA, MD, ME, MG, MK, MN, MW, MX, MY, MZ, NA, NG, NI, NO, NZ, OM, PG, PH, PL, PT, RO, RS, RU, SC, SD, SE, SG, SK, SL, SM, ST, SV, SY, TJ,

[Continued on next page]

(54) Title: SURGICAL INSTRUMENT ACCESS DEVICE



(57) Abstract: Embodiments of an access device system useful for single or limited port procedures comprises a retractor and a gel cap removably coupled to the retractor. The gel cap comprises a gel pad that acts as an artificial body wall, through which instruments may be inserted into a body cavity, either directly or through one or more trocars. The gel pad permits flexible instrument placement, as well as translational and angular degrees of freedom for the instruments while maintaining a gas tight seal.

WO 2009/094476 A1



TM, TN, TR, TT, TZ, UA, UG, US, UZ, VC, VN, ZA, ZM, ZW.

**(84) Designated States** (*unless otherwise indicated, for every kind of regional protection available*): ARIPO (BW, GH, GM, KE, LS, MW, MZ, NA, SD, SL, SZ, TZ, UG, ZM, ZW), Eurasian (AM, AZ, BY, KG, KZ, MD, RU, TJ, TM), European (AT, BE, BG, CH, CY, CZ, DE, DK, EE, ES, FI,

FR, GB, GR, HR, HU, IE, IS, IT, LT, LU, LV, MC, MK, MT, NL, NO, PL, PT, RO, SE, SI, SK, TR), OAPI (BF, BJ, CF, CG, CI, CM, GA, GN, GQ, GW, ML, MR, NE, SN, TD, TG).

**Published:**

— *with international search report*

## SURGICAL INSTRUMENT ACCESS DEVICE

### CROSS-REFERENCE TO RELATED APPLICATION

[0001] This application claims the benefit of U.S. Application No. 61/022,772, filed January 22, 2008, and U.S. Application No. 61/104,963, filed October 13, 2008, the entire disclosures of which are incorporated by reference.

### BACKGROUND

#### Technical Field

[0002] This application is generally directed to surgical devices, and more particularly, to an artificial body wall useful in single-port laparoscopic surgical procedures.

#### Description of the Related Art

[0003] Access devices are commonly used in surgery to facilitate the introduction of various surgical instruments into natural biological vessels, conduits, orifices, cavities, and other interior regions of the body. These access devices include, for example, devices that facilitate the introduction of a needle into a vessel, and trocars that facilitate the introduction of laparoscopic instruments into the abdomen of the body.

[0004] Some of these access devices are introduced into regions that include a fluid or gas under pressure. In the case of a needle access device, the pressure may be from a liquid, such as blood. In the case of a trocar, the pressure may be from a gas, such as an insufflation gas. In either case, it is desirable to provide for the introduction of the surgical instrument into the cavity without permitting the escape of the pressurized fluid or gas.

[0005] In the case of trocars, a cannula at the distal end of the trocar is typically connected to a seal housing at the proximal end of the trocar. Together the cannula and housing form a working channel through which various instruments can be inserted to access the cavity. Seal mechanisms are commonly disposed in the housing and include a septum valve that seals the working channel when an instrument is in place, and a zero closure valve that seals the working channel when the instrument is removed.

[0006] Current surgical access ports allow for single instrument access through each port, or allow for multiple instrument access through a rigid cannula. Some devices,

- 2 -

such as transanal endoscopic microsurgery (TEMS) units, require that instruments be placed through fixed points located on the device, and also require that the device be attached to the surgical table to support the weight of the device, as well as to locate the position of the device relative to the patient. These devices do not provide flexibility to the surgeon in selecting instrument size, and they restrict instrument movement with their rigid cannulas. Additionally, surgeons are performing laparoscopic surgical procedures through a single or a limited number of access ports. In these procedures, the surgeon places multiple instruments through a single or a limited number of access ports. The procedures may be performed through a single two (2) centimeter incision at the umbilicus, or in certain cases, trans-vaginally or trans-anally. What is needed is a system that meets the needs of these new procedures and allows more options for the surgeons.

#### SUMMARY OF THE INVENTION

**[0007]** Embodiments of an access device system useful for single or limited port procedures comprises a retractor and a gel cap removably coupled to the retractor. The gel cap comprises a gel pad that acts as an artificial body wall, through which instruments may be inserted into a body cavity, either directly or through one or more trocars. The gel pad permits flexible instrument placement, as well as translational and angular degrees of freedom for the instruments while maintaining a gas tight seal.

**[0008]** Accordingly, some embodiments provide a surgical access port adapted for performing laparoscopic surgical procedures at a single access site wherein an incision is made in the abdominal wall of a patient and the abdominal cavity is pressurized with an insufflation gas, the access port adapted to provide access to the abdominal cavity for surgical procedures while maintaining insufflation pressure in the abdominal cavity, the surgical access port comprising: an adjustable wound retractor comprising: a proximal ring, wherein the proximal ring is configured to be disposed proximate the outer surface of the abdominal wall of the patient and substantially surround the incision; a retraction sheath comprising a tubular wall, a proximal portion coupled to the proximal ring during use, and a distal portion, wherein the retraction sheath is configured to be disposed through the incision and line the incision, and wherein the retraction sheath is adjustable to retract the incision; and a distal ring coupled to the distal portion of the retraction sheath, wherein the distal ring is configured

to be disposed proximate the inner surface of the abdominal wall and substantially surround the incision; and a gel cap configured to be coupled to the proximal ring, comprising: a cap ring, wherein the cap ring is configured to substantially surround the incision; a gel pad disposed within the cap ring; and a plurality of sealing valves operatively attached to the gel pad, wherein the plurality of sealing valves at least partially form a plurality of access channels through the gel pad, and wherein the plurality of sealing valves are configured to form seals with instruments extending through the sealing valves and form seals in the absence of any instruments extending through the sealing valves.

**[0009]** In some embodiments, at least a portion of at least one of the sealing valves defines an orifice. In some embodiments, at least a portion of at least one of the sealing valves comprises a septum seal. In some embodiments, at least a portion of at least one of the sealing valves comprises a duck bill valve. In some embodiments, at least one of the sealing valves has a low profile. In some embodiments, at least one of the sealing valves has a first size to accommodate an instrument of the first size, and at least another of the sealing valves has a second size to accommodate an instrument of the second size.

**[0010]** In some embodiments, at least one of the sealing valves is configured such that the sealing valve is repositionable relative to the cap ring during use. In some embodiments, at least one of the sealing valves is configured such that the sealing valve is translatable relative to the cap ring during use. In some embodiments, at least one of the sealing valves is configured such that the sealing valve is pivotable relative to the cap ring during use. In some embodiments, at least one of the sealing valves is configured such that the sealing valve is held generally stationary relative to the cap ring during use.

**[0011]** In some embodiments, the gel cap is configured to be removably coupled to the proximal ring during use. In some embodiments, the gel cap is fixed to the proximal ring.

**[0012]** In some embodiments, the proximal ring of the wound retractor is rotatable to adjustably retract the incision during use. In some embodiments, the retraction sheath is stretchable to adjustably retract the incision during use.

**[0013]** Some embodiments additionally comprise a tether coupled to the distal ring. In some embodiments, at least a portion of the distal ring has a non-circular cross

section that facilitates folding the distal ring and insertion through the incision. In some embodiments, the distal ring has a tear-drop-shaped cross section that facilitates folding the distal ring and insertion through the incision. In some embodiments, the distal ring comprises at least one notch that facilitates folding of the distal ring and insertion through the incision.

**[0014]** Some embodiments provide a surgical access port adapted for performing a surgical procedure at an access site wherein a body cavity of a patient is pressurized with an insufflation gas, the access port adapted to provide access to the body cavity for surgical procedures while maintaining insufflation pressure in the body cavity, the surgical access port comprising: an adjustable retractor comprising: a proximal ring, wherein the proximal ring is configured to be disposed proximate the outer surface of the body wall of the patient; a retraction sheath comprising a tubular wall, a proximal portion coupled to the proximal ring during use, and a distal portion, wherein the retraction sheath is configured to be disposed through an opening in the body wall of the patient, and wherein the retraction sheath is adjustable to retract the opening in the body wall; and a distal ring coupled to the distal portion of the retraction sheath, wherein the distal ring is configured to be disposed proximate the inner surface of the body wall of the patient; and a sealing cap configured to be coupled to the proximal ring, comprising: a cap ring substantially surrounding a flexible material disposed within the cap ring; and a sealing valve positioned within the cap ring and substantially surrounded by and operatively attached to the flexible material, wherein the sealing valve at least partially forms an access channel through the flexible material, and wherein the sealing valve is configured to form a seal with an instrument extending through the sealing valve and form a seal in the absence of any instrument extending through the sealing valve.

**[0015]** In some embodiments, the flexible material comprises a gel.

**[0016]** In some embodiments, the sealing valve is repositionable relative to the cap ring during use. In some embodiments, the sealing valve is translatable relative to the cap ring during use. In some embodiments, the sealing valve is pivotable relative to the cap ring during use.

**[0017]** In some embodiments, the sealing cap comprises a plurality of sealing valves positioned within the cap ring and substantially surrounded by the flexible material,

wherein the plurality of sealing valves at least partially form a plurality of access channels through the flexible material, and wherein the plurality of sealing valves are configured to form seals with instruments extending through the sealing valves and form seals in the absence of any instruments extending through the sealing valves.

**[0018]** Some embodiments additionally comprise a tether coupled to the distal ring. In some embodiments, at least a portion of the distal ring has a non-circular cross section that facilitates folding the distal ring and insertion through the incision.

**[0019]** Some embodiments provide a surgical access port adapted for performing laparoscopic surgical procedures at an access site wherein an incision is made in the abdominal wall of a patient and the abdominal cavity is pressurized with an insufflation gas, the access port adapted to provide access to the abdominal cavity for surgical procedures while maintaining insufflation pressure in the abdominal cavity, the surgical access port comprising: an adjustable wound retractor having a proximal ring, a distal ring, and a retraction sheath extending between the proximal ring and the distal ring, the proximal ring being configured to be disposed proximate the outer surface of the abdominal wall of the patient, the distal ring being configured to be disposed proximate the inner surface of the abdominal wall of the patient, and the a retraction sheath comprising a tubular wall having a proximal portion coupled to the proximal ring during use and a distal portion coupled to the distal ring during use, wherein the retraction sheath is configured to be disposed through the incision and line the incision, and wherein the retraction sheath is adjustable to retract the incision; and a sealing cap configured to be coupled to the proximal ring during use, the sealing cap comprising a plurality of sealing valves, wherein the plurality of sealing valves at least partially form a plurality of access channels through the sealing cap, wherein the plurality of sealing valves are configured to form seals with instruments extending through the sealing valves and form seals in the absence of any instruments extending through the sealing valves, and wherein at least one of the sealing valves is repositionable relative to at least another one of the sealing valves during use.

**[0020]** In some embodiments, the sealing cap comprises a gel.

**[0021]** In some embodiments, the at least one repositionable sealing valve is translatable relative to the at least another one of the sealing valves. In some embodiments,

the at least one repositionable sealing valve is pivotable relative to the at least another one of the sealing valves.

**[0022]** Some embodiments additionally comprise a tether coupled to the distal ring. In some embodiments, at least a portion of the distal ring has a non-circular cross section that facilitates folding the distal ring and insertion through the incision.

**[0023]** Some embodiments provide an access device system comprising: a retractor and a gel cap. The retractor comprises an inner ring, an outer ring, and a flexible sleeve extending between the inner ring and the outer ring. The outer ring comprises an outer component and an inner component, wherein the inner component defines an annular axis around which the outer component is rotatable, thereby winding and unwinding the flexible sleeve therearound. The gel cap comprises an annular cap ring coupled to the outer ring of the retractor and a gel pad disposed in and coupled to the annular cap ring. The gel pad does not comprise a preformed access channel therethrough.

**[0024]** Some embodiments provide an access device system comprising: a retractor and a gel cap. The retractor comprises an inner ring, an outer ring, and a flexible sleeve extending between the inner ring and the outer ring. The outer ring comprises an outer component and an inner component, wherein the inner component defines an annular axis around which the outer component is rotatable, thereby winding and unwinding the flexible sleeve therearound. The gel cap comprises an annular cap ring coupled to the outer ring of the retractor and a gel pad disposed in and coupled to the annular cap ring. At least one access port comprising a first seal and a second seal is at least partially embedded in the gel pad, wherein the first seal comprises an instrument seal and the second seal comprises a zero seal.

**[0025]** Some embodiments of the access device system further comprise a trocar comprising a longitudinal axis defining an access channel; a proximal end; a distal end; a tubular cannula; a seal assembly disposed at the proximal end of the cannula; and a retainer disposed at the distal end of the cannula. The seal assembly comprises an instrument seal and a zero seal. The proximal end of the retainer comprises a face that is substantially perpendicular to the longitudinal axis. A diameter of the retainer convergently tapers from the proximal end to the distal end thereof.

[0026] Some embodiments provide a single port access device system comprising a retractor and an artificial body wall couplable to the retractor, wherein the artificial body wall comprises a plurality of access channels dimensioned and configured for instrument access therethrough, and wherein instruments inserted through the access channels are relatively translatable and relatively pivotable.

#### BRIEF DESCRIPTION OF THE DRAWINGS

[0027] FIG. 1 is a side view of a patient in surgery illustrating an embodiment of the access device positioned on the abdomen and in use.

[0028] FIG. 2 is a cross-sectional side view illustrating an embodiment of the access device, with the wound retractor retracting the vagina of a patient, and the gel cap sealing the opening of the wound retractor.

[0029] FIG. 3 is a front view illustrating an embodiment of the access device deployed and in use at the mouth of the patient.

[0030] FIG. 4 is a top view illustrated a patient in the prone position with an embodiment of the access device deployed and in use at the anus of the patient.

[0031] FIG. 5 is a perspective view of an embodiment of an access device comprising a cap and a retractor.

[0032] FIG. 6A is a partial side cross section of an embodiment of a retractor. FIGS. 6B–6D illustrate cross sections of embodiments of inner rings.

[0033] FIG. 7 is a partial side cross section of another embodiment of a retractor.

[0034] FIG. 8A is a side view of an embodiment of a retractor comprising a tether. FIG. 8B is a side view of a method for removing the retractor illustrated in FIG. 8A.

[0035] FIG. 9A is a side view of an embodiment of an insertion/removal device for a retractor and a method for inserting a retractor. FIG. 9B is a side view of another embodiment of an insertion/removal device for a retractor and a method for inserting a retractor. FIG. 9C is a side view of a method for removing a retractor using the device illustrated in FIG. 9B.

[0036] FIG. 10A is a top perspective view of an embodiment of a gel cap. FIG. 10B is a bottom view of an embodiment of a cap ring.

[0037] FIG. 11A is a top view of an embodiment of a gel cap comprising a plurality of access ports embedded in the gel pad. FIG. 11B is a top perspective view of the gel cap illustrated in FIG. 11A. FIG. 11C is a bottom perspective view of the gel cap illustrated in FIG. 11A.

[0038] FIG. 11D is a top perspective view of the gel cap illustrated in FIG. 11A with instruments inserted through two of the access ports. FIG. 11E is a bottom perspective view of the gel cap and instruments illustrated in FIG. 11D. FIG. 11F is a side view of the gel cap and instruments illustrated in FIG. 11D.

[0039] FIG. 11G is a top perspective view of an embodiment of gel cap comprising a fixed camera or laparoscope port.

[0040] FIG. 12 is a cutaway perspective view of an embodiment of an access device system comprising a gel cap that snap fits to a retractor.

[0041] FIG. 13 is an exploded view of an embodiment of a trocar.

[0042] Similar components have similar reference numbers throughout.

#### DETAILED DESCRIPTION OF CERTAIN EMBODIMENTS

[0043] Embodiments of the surgical instrument access device system are useful, for example, for single incision, single port, and/or limited port laparoscopic surgical procedures, for example, abdominal (FIG. 1), transvaginal (FIG. 2), transoral (FIG. 3), and transanal (FIG. 4) procedures.

[0044] FIG. 5 illustrates a perspective view of an embodiment of an access device system 5000 comprising a retractor 5100 and a cap 5500, which is useful in single port and/or limited port procedures. The retractor or surgical wound retractor 5100 is placed and/or positioned into, across, and/or through a surgical incision and/or body orifice to enlarge, reshape, and/or isolate the incision or body orifice. The cap 5500 provides an artificial body wall through which instruments access the interior of a patient's body, for example, a body cavity. The components of the access device 5000 comprise any suitable biologically compatible materials. Other embodiments of access device systems are described in U.S. Patent Publication No. 2007/0088204 A1, the disclosure of which is incorporated.

[0045] The embodiment of the retractor 6100 illustrated in a partial side cross section in FIG. 6A comprises an inner or distal ring 6110, an outer or proximal ring 6120,

and a sleeve or retraction sheath **6130** extending between and coupling the inner ring **6110** and the outer ring **6120**. The sleeve **6130** comprises a flexible membrane, which is substantially cylindrical in the illustrated embodiment. In other embodiments, the sleeve **6130** has another shape, for example, an oval cross section. Embodiments of the sleeve **6130** comprise a flexible, semi-transparent polymer film. Some embodiments of the sleeve **6130** comprise one or more coatings that provide additional functionality, for example, an anti-microbial coating.

**[0046]** Embodiments of the inner ring **6110** are sufficiently flexible and compliant to be compressed and/or deformed for insertion through an incision and/or body orifice. When subsequently released within an associated body cavity, the inner ring **6110** substantially returns to its original shape or footprint. In some embodiments, the inner ring **6110** assumes a substantially circular shape in a relaxed state, for example, when released within a body cavity. In other embodiments, the inner ring **6110** has another shape in the relaxed state, for example, an oval. The inner ring **6110** assumes a different shape when compressed for insertion through an incision or body orifice, for example, a substantially oval shape, a generally linear shape, a tear-drop shape, or another suitable shape. Those skilled in the art will recognize that in other embodiments, the inner ring **6110** in the relaxed state has a shape other than round, for example, oval, elliptical, or D-shaped. In other embodiments, the inner ring **6110** is substantially rigid, that is, non-compliant under the ordinary conditions under which it is used.

**[0047]** Embodiments of the inner ring **6110** comprise a circular cross section as illustrated in FIG. **6A**. In other embodiments, the inner ring **6110** comprises another cross-sectional shape, for example, at least one of oval or elliptical (FIG. **6B**), tear-drop shaped (FIG. **6C**), and D-shaped (FIG. **6D**). Those skilled in the art will understand that other cross sections are used in other embodiments. Some embodiments of the inner ring **6110** comprise at least one notch and/or weak spot, which facilitate folding or deforming the inner ring **6110**, thereby facilitating insertion and/or removal of the inner ring **6110**.

**[0048]** Some embodiments of the inner ring **6110** comprise one or more lumens extending therethrough. For example, the embodiment of the inner ring **6110** illustrated in FIG. **6A** comprises a lumen **6112**. Embodiments of the lumen **6112** provide at least one of

improved resilience and improved flexibility. In some embodiments a wire is disposed within the lumen **6112**, for example, a spring-metal wire, thereby modifying the resilience of the inner ring **6110**. In some embodiments, the lumen or lumens **6112** improve the compressibility of the inner ring **6110**, thereby facilitating insertion into and/or removal from a body cavity. For example, in some embodiments, the lumen(s) **6112** increase the flexibility of the inner ring **6110**, for example, permitting a smaller radius fold and/or a flatter compressed state. In some embodiments, a more flexible inner ring **6110** improves sealing of the retractor to an inner wall of the body cavity. In some embodiments, an inner ring **6110** comprising one or more lumens **6112** compresses to a smaller size and/or cross section than a similar inner ring **6110** without a lumen, for example, by collapsing the lumen(s) **6112** in the compressed state.

[0049] In some embodiments, the inner ring **6110** is manufactured as a monolithic ring or toroid. In other embodiments, the inner ring **6110** is manufactured from a generally linear body comprising a first end and a second end, which are brought together to provide a closed form. The first end and second end are then joined using any suitable means or method known in the art, for example, by at least one of adhesively, welding, melting, mechanically, and the like. In some embodiments, the first end and second end of the linear body are joined using a coupler. In some embodiments, the coupler engages the lumen **6112**, for example, comprising a first finger and a second finger dimensioned to be received within the lumen **6112** at the first end and the second end of the body, respectively, where the first and second fingers extend in opposite directions from a common locus of the coupler. In some embodiments, the coupler prevents relative rotation between the first end and the second end of the body of the coupler.

[0050] Returning to FIG. 6A, the outer ring **6120** includes an outer component **6122** and an inner component. In the illustrated embodiment, the outer component **6122** has a substantially circular footprint and a substantially oval cross section. In other embodiments, the outer component **6122** has another cross-sectional shape, for example, rectangular, hexagonal, octagonal, or another suitable shape. In the illustrated embodiment, a cross-sectional height of the outer component **6122** is larger than a cross-sectional width thereof. In some embodiments, a ratio between the height and width of the cross-section relates to

factors including an overall hardness and/or rigidity of the outer component **6122** and a diameter of the outer ring **6120**. More particularly, a softer outer component **6122** correlates with a larger ratio between the cross-sectional height and width of the outer component **6122** in some embodiments. Similarly, increasing the diameter of the outer component **6122** increases the ratio between the cross-sectional height and width of the outer component **6122**. Embodiments of the outer component **6122** comprise a thermoplastic elastomeric material, such as a thermoplastic polyester elastomer and/or a thermoplastic polyether ester elastomer (HYTREL®, DuPont, Wilmington, Delaware) and/or a thermoplastic polyurethane elastomer (PELLETHANE®, Dow Chemical, Midland, Michigan). Embodiments of the outer component **6122** are extruded, injection molded, compression molded, or over-molded. Some embodiments of extruded outer components **6122** have the ends produced thereby heat sealed together.

[0051] In the embodiment illustrated in FIG. 6A, the outer component **6122** of the outer ring comprises three lumens **6124** – a first or middle lumen **6124a**, a second or top lumen **6124b**, and third or bottom lumen **6124c** – extending circumferentially therethrough. In some embodiments, one or both of the top lumen **6124b** and bottom lumen **6124c** are optional. The middle lumen **6124a** is disposed about at the center of the outer component **6122**, substantially at the intersection of the major and minor axes of the oval cross section thereof. The top lumen **6124b** is disposed substantially on the major axis, on a first side of the minor axis or above the middle lumen **6124a**. The bottom lumen **6124c** is disposed substantially on the major axis, on a second side of the minor axis or below the middle lumen **6124a**. The middle lumen **6124a** has an oval cross-section and is larger than the top lumen **6124b** and the bottom lumen **6124c** in the illustrated embodiment. The top lumen **6124b** and bottom lumen **6124c** each has a tear-dropped cross-section comprising a tapered portion disposed away from the middle lumen **6124a**. In other embodiments, each of the lumens **6124** independently has another cross-sectional shape, for example, a generally circular cross section. In some embodiments, the cross-sectional shape of a lumen **6124** reduces contact between the lumen **6124** and an inner component (discussed below) disposed therein, thereby reducing friction and/or drag therebetween. For example, in some embodiments, the lumen **6124** has a polygonal cross section, for example, generally square, rectangular, diamond-

shaped, hexagonal, star-shaped or the like. In some embodiments, a wall of the lumen is textured, thereby reducing contact and friction with an inner component disposed therein.

[0052] Some embodiments of the outer component **6122** of the outer ring comprise a split member, such as a substantially straight member having a first end and a second end. The first and second ends of the member are brought proximate each other and coupled together, as will be discussed in more detail below.

[0053] Some embodiments of the inner component of the outer ring comprise a generally circular rigid wire **6126**. In other embodiments, the rigid wire has another shape, for example, generally oval or elliptical. In the illustrated embodiment, the inner component is disposed in the middle lumen **6124b** of the outer component **6122**. The wire **6126** of the inner component is not compliant or resilient relative to the body tissue of the surgical incision or natural body orifice. Accordingly, the wire **6126** does not flex, yield, and/or deform relative to the body tissue of the surgical incision or natural body orifice during retraction of the incision or body orifice. In the illustrated embodiment, the rigid wire **6126** defines the peripheral shape or footprint, of the outer ring **6120** of the wound retractor. The rigid wire **6126** serves as an axle, annular axis, or center point for rotating the outer component **6122** of the outer ring during retraction, as discussed in greater detail below. The wire **6126** comprises a suitable material that is significantly harder than the outer component **6122** of the outer ring, for example full hard stainless steel. Some embodiments of the rigid wire of the inner component comprise a split wire **6126** having a first end and a second end. In some embodiments, the first and second ends of the rigid wire **6126** are coupled together using any suitable method, for example, by at least one of welding, using an adhesive, and/or using a mechanical fastener or coupler.

[0054] As indicated above, the inner component of the outer ring may comprise a generally circular rigid wire **6126**. A diameter of the rigid wire **6126** is from between about 0.25 mm to about 12.7 mm (about 0.01 inch to about 0.5 inch). The diameter of the wire **6126** varies with the wound size and/or the size of the retractor **6100**. For example, a larger wound size correlates with a larger wire diameter. In some embodiments, the wire diameter also correlates with the wire material. For example, increasing a hardness of the wire material permits reducing the wire diameter.

[0055] Some embodiments of the rigid wire **6126** for the inner component of the outer ring begin as a straight wire. The straight wire is inserted into the middle lumen **6124a** of outer component. When the first and second ends of the outer component **6122** of the outer ring are joined, the wire assumes the desired shape, for example, a substantially circular shape or an oval shape, placing the wire **6126** in a preloaded condition under which the wire **6126** has a tendency to straighten. The tendency of the wire **6126** to straighten out helps the outer ring **6120** to maintain the desired shape, for example, circular or oval.

[0056] Some embodiments of the outer ring **6120** comprise a single, monolithic coupler **6128** that couples the first and second ends of the outer component **6122** of the outer ring together, and that couples the first and second ends of the wire **6126** of the inner component of the outer ring together. Embodiments of the single, monolithic coupler comprise a polymer, plastic, or other suitable material. In some embodiments, the monolithic coupler comprises of at least one of a thermoplastic elastomer (HYTREL®, DuPont; PELLETHANE®, Dow), acrylonitrile-butadiene-styrene (ABS), polyamide (NYLON®, DuPont), polyether block amide (PEBAX®, Arkema), and high density polyethylene (HDPE).

[0057] In some embodiments, the inner ring **6110** and the outer ring **6120** independently have different footprint shapes and/or footprint diameters. An inner ring **6110** with a larger diameter permits a greater retraction force, but is more difficult to insert and remove from a body cavity. An outer ring **6120** with a larger diameter is easier to roll or rotate when retracting, but couple with a larger cap, and consequently, may not be useable in space constrained procedures. Oval or elongated inner rings **6110** and outer rings **6120** reduce the force required to retract long, straight incisions compared with circular versions.

[0058] Some embodiments of the outer ring **6120** further comprise one or two split hoops disposed in one or both of the top lumen **6124b** and the bottom lumen **6124c**. Split hoops are discussed in greater detail below.

[0059] In some embodiments, the inner ring **6110** comprises a material that is softer than the material of the outer component **6122** of the outer ring. In other embodiments, the inner ring **6110** comprises a material of about the same hardness as the material of outer

component **6122** of the outer ring, or harder than the material of the outer component **6122** of the outer ring.

[0060] FIG. 7 illustrates a partial side cross section of another embodiment of a retractor **7100** generally similar to the embodiment **6100** described above. The retractor **7100** comprises an inner ring **7110**, an outer ring **7120**, and a sleeve **7130** extending between and coupling the inner ring **7110** and the outer ring **7120**. In the illustrated embodiment, the outer ring **7120** of the wound retractor includes an outer component **7122** having a substantially oval cross-section including a first lumen **7124a** and a second lumen **7124b**. Each of the first **7124a** and second **7124b** lumens is positioned substantially along the major axis of the oval cross section with the first lumen **7124a** positioned on a first side of the minor axis of the oval and the second lumen **7124b** positioned on a second, opposite side of the minor axis of the oval. The inner component of the outer ring **7120** of the wound retractor includes a first split hoop **7126a** disposed in the first lumen **7124a** of the outer component of the outer ring, and a second split hoop **7126b** disposed in the second lumen **7124b** of the outer component. In some embodiments, each of the first **7126a** and second **7126b** split hoops independently comprises a hoop having a single split about its periphery with the split creating a first end of the split hoop and a second end of the split hoop. In its neutral position, the first and second ends of the respective split hoops substantially abut each other. In some embodiments, the split hoops **7126** are substantially noncompliant under the conditions in which the retractor **7100** is used, for example, as compared to tissues of a body wall under retraction, the outer component **7122** of the outer ring, and the sleeve **7120**.

[0061] In some embodiments, properties of the retractor **7100** including the retraction force applied by the retractor **7100** and the ease of retracting an opening in a body wall depends at least in part on a spacing between the first **7124a** and second **7124b** lumens of the outer component of the outer ring, and a cross-sectional size or diameter of the first **7126a** and second **7126b** split hoops of the inner component of the outer ring. During use, the outer ring **7120** of the wound retractor is rolled down the sleeve **7130**, thereby placing the split hoop **7126** proximal to the user under tension, opening the split hoop **7126** by creating a space between the first and second ends of the hoop **7124**. In contrast, the rolling places the split hoop **7126** distal to the user under compression, forcing the first and second ends thereof

together. In this manner, the rigid split hoop **7124** distal to the user serves as an axle or center of rotation for the outer ring **7120**. Either or both increasing a distance between the two split hoops **7126** further apart, or increasing the strength of the split hoops **7126**, increases the force used in rolling or rotating the outer ring **7120** of the wound retractor. Accordingly, the spacing or distance between the first **7124a** and second **7124b** lumens, and the cross-sectional sizes or diameters of the first **7126a** and second **7126b** split hoops are selected to balance the force for rotating the outer ring **7120** when retracting a body wall against the tendency of the outer ring to unroll **7120** under the force applied to the outer ring by the retracted body wall.

**[0062]** In some embodiments, the first **7126a** and second **7126b** split comprise a metal, for example, full-hard temper wire, stainless steel, piano wire heat treated to a spring temper, or any other suitable metal that produces a substantially noncompliant hoop. In some embodiments, the first **7126a** and second **7126b** split hoops comprise a rigid polymeric material fabricated by any suitable material, for example, by molding, machining, and/or and other suitable process known in the art. The substantially noncompliant split hoops **7126** may also comprise any other suitable rigid material known in the art.

**[0063]** In some embodiments, the cross-sectional diameters of the first **7126a** and second **7126b** split hoops vary with the cross-sectional dimensions of the outer component **7122** of the outer ring, and with the size and dimensions of the incision or body opening to be retracted. In some embodiments, a wire diameter of from about 2.5 mm to about 3.5 mm, for example, about 3 mm is used in retracting incisions of from about 5 cm to about 9 cm long. In some embodiments, each of the first **7126a** and second **7126b** hoops independently comprises a wire of from about 0.25 mm to about 6.35 mm (from about 0.01 inch to about 0.25 inch) in diameter.

**[0064]** The first **7126a** and second **7126b** split hoops of the inner component of the outer ring have smaller diameters in their relaxed states than the first lumen **7124a** and the second lumen **7124b** in which each is respectively disposed. Accordingly, when the outer ring **7120** is in a relaxed state, each of the split hoops **7126** is under tension, while the outer component **7122** is under compression. Consequently, in some embodiments, the split hoops **7126** hold the outer component **7122** of the outer ring in a closed configuration. In some embodiments, the compressive force of the first **7126a** and second **7126b** split hoops also

control the orientation of the outer component **7122** in the relaxed state: that is, with the split hoops **7126** substantially one above the other, and/or with the major axis of the cross section of the outer component **7122** substantially parallel to a longitudinal axis of the outer component **7122**.

[0065] In some embodiments, each split hoop **7126** is fabricated as a circle or other desired shape with the first and second end portions thereof overlapping each other. In some embodiments, dimensions of the first lumen and the second lumen **7124b** and the composition of outer component **7122** of the outer ring constrain the first and second end portions of each split hoop from overlapping each other when the first split hoop **7126a** and second split hoop **7126b** are respectively disposed therein. In some embodiments, the lumens **7124** are dimensioned such that the first and second ends of each split hoop **7126** substantially abut each other when disposed therein. Other embodiments comprise a slight gap between the first and second ends of at least one split hoop **7126** disposed in the lumen **7124**. The compressive spring force from the expanded split hoops urges the outer component **7122** to remain in a closed shape. Because the split hoops **7126** are disposed on either side of the minor axis of the cross section of the outer component **7122**, the first **7126a** and second **7126b** split hoops urge and maintain the configuration of the outer ring **7120** such that the major axis of the cross section of the outer component **7122** remains vertical at 0° and 180° orientations, thereby facilitating the attachment of the cap to the outer ring **7120** of the wound retractor, as discussed below. In some embodiments, the outer ring **7120** is designed with an orientational bias other than vertical, for example, by changing at least one of the relative positions of the lumens **7124**, the relative diameters of the lumens **7124**, the relative relaxed diameters of the split hoops **7126**, the relative cross-sectional diameters of the split hoops **7126**, and the relative compositions of the split hoops **7126**.

[0066] Because each of the first **7126a** and second **7126b** split hoops has substantially abutting first and second ends when the outer ring **7120** is in a relaxed configuration, each of the split hoops **7126** successively functions as an axle about which the outer component **7122** undergoes a half or 180° rotation in the retraction process. More particularly, as the outer ring **7120** is rolled, the first split hoop **7126a**, which is initially above the second split hoop **7126b**, is rolled or rotated around and outside the second split

hoop **7126b**, which serves as an axle or axis for the rotation, with the periphery of the first split hoop **7126a** expanding to clear and pass around the second split hoop **7126b**, resulting in the first split hoop **7126a** below the second split hoop **7126b**. On continued rolling of the outer ring **7120**, the roles of the first **7126a** and second **7126b** split hoops are reversed, with the second split hoop **7126b** rolling around and outside the first split hoop **7126a** with the periphery of the second split hoop **7126b** expanding to clear and pass around the first split hoop **7126a**, which serves as an axle for the rotation. These steps are repeated until the incision or body opening is retracted to the desired degree.

[0067] In some embodiments, the outer ring **7120** of the wound retractor comprises an extruded elastomeric tube with a desired shape, for example, a generally circular or oval ring. In some embodiments, the first **7126a** and second **7126b** split hoops disposed in the first **7124a** and second **7124b** lumens of the outer component **7122**, respectively, serves as a framework or scaffolding for the outer ring **7120**, and consequently, determine the general shape thereof. In some embodiments, one of the first and second ends of the first split hoop **7126a** is inserted into the first lumen **7124a** of outer component, and one of the first and second ends of the second split hoop **7126b** is inserted into the second lumen **7124b** of the outer component. Each of the first **7126a** and second **7126b** split hoops is continually fed into its respective lumens **7124** until each of the split hoops **7126** is substantially entirely within its respective lumen **7124**. The outer component **7122** generally assumes the shape of the split hoops **7126** positioned in the first **7124a** and second **7124b** lumens thereof. Some embodiments further comprise a coupler disposed between the first and second ends of the outer component **7122**.

[0068] Referring again to the outer component **7122** of the outer ring, a ratio between a cross-sectional height and cross-sectional width thereof creates lock points as the outer component **7122** is rotated around the inner component. As the sleeve **7230** rolls-up around the outer ring **7120** when rotating the outer ring **7120**, the lock points reduce or prevent the outer ring **7120** from rotating backwards, thus prevent the sleeve **7230** from unraveling or unrolling from the outer ring **7120**. These lock points also provide incremental rotational positions for the outer ring **7120**, thereby providing incremental retraction of the wound. Generally symmetrical cross-sectional shapes provide substantially uniform rotational

motion and lock points, thereby providing a substantially uniform “snap” feel with each incremental rotation. The lock points also help keep the first, outer component of the second, outer ring from tilting as a result of forces encountered when retracting the surgical incision or body orifice. The illustrated embodiment comprises lock points where the cross-sectional major axis of the outer component **7120** is generally vertical, parallel to the longitudinal axis of the outer component **7120**, or at  $0^\circ$  and  $180^\circ$ .

[0069] As stated above, embodiments of the outer component **7120** comprise a thermoplastic elastomeric material, such as HYTREL® (DuPont) or PELLETHANE® (Dow). Increasing the hardness of the material of the outer component **7122** increases the force used to rotate the outer ring **7120**, as well as the resistance to unlock the outer ring **7120** from each lock point with each rotation of the outer ring **7120**. Accordingly, the hardness of the material of the outer component **7122** in conjunction with the cross-sectional height and width of the outer component **7122** are selected to provide suitable or sufficient lock points for the outer ring **7120**. For example, increasing the cross-sectional height-to-width ratio of the outer component **7122** permits reducing the material hardness while providing similar lock-point resistance or “snap”. Conversely, increasing the material hardness permits reducing the cross-sectional height-to-width ratio of the outer component **7122**.

[0070] Embodiments of the footprint of the outer ring **7120** are symmetrical or non-symmetrical and can vary in size and shape, such as a circle, ellipse, oval, or any other suitable shape, to conform to a body type, position, or size, thereby increasing or improving working space, or reducing potential interference with other instruments or ports during a laparoscopic procedure.

[0071] Reducing the cross-sectional profile or dimension of the outer ring **7120** of the wound retractor increases a range of insertion angles for instruments inserted therethrough. More particularly, one or both of the cross-sectional height and width of the outer ring **7120** may be reduced. The increased insertion-angle range is particularly useful for body orifice retraction, such as rectal or vaginal retraction. Reducing the cross-sectional profile of the outer ring **7120** increases the difficulty of rolling or rotating the outer component **7122** of the outer ring about the inner component of the outer ring **7120** during

retraction. Accordingly, in some embodiments, a suitable tool used to facilitate rolling the outer component **7122** about the inner component.

[0072] An embodiment of a procedure for retracting an incision or body orifice is described with reference to the embodiment of the retractor **6100** illustrated in FIG. **6A**, although the procedure is applicable to all of the embodiments of the retractor disclosed herein. In use, the surgical wound retractor **6100** is inserted into an incision, such as an incision made in an abdominal wall (FIG. **1**), or a body orifice, such as the vagina (FIG. **2**), mouth (FIG. **3**) or anus (FIG. **4**). The inner ring **6110** is folded or compressed into an oval or other suitable shape and urged through the incision or body orifice into an associated body cavity. Once the inner ring **6110** is fully disposed within the associated body cavity, it is allowed to resume its original, relaxed shape, for example, substantially circular, oval, or other original shape. The inner ring **6110** is then pulled upward against the inner surface of the body cavity, for example, by pulling the outer ring **6120** upward.

[0073] When the inner ring **6110** is fully in place, the outer ring **6120** is rotated rolled about its annular axis, which is defined by the inner component thereof. As discussed above, in the rolling procedure, the portion of the outer component **6122** distal from the user moves passes through the interior of the annular axis in moving towards the user, while the portion of the outer component **6122** proximal to the user passes around the exterior of the annular axis in moving away from the user. Rolling the outer ring **6120** rolls the sleeve **6130** around the outer ring **6120**, reducing the distance between the inner ring **6110** and the outer ring **6120** and tensioning the sleeve **6130** therebetween, thereby retracting the incision or body orifice.

[0074] The outer ring **6120** is rolled until a desired state or degree of retraction is attained with the outer ring **6120**, with a portion of the sleeve wrapped therearound, substantially in contact with the exterior surface of the body wall. When the outer ring **6120** and portion of the sleeve wrapped therearound is in contact with the exterior surface of the body wall, the outer ring **6120** of the retractor is sufficiently rigid to maintain the desired state or degree of retraction of the incision or body opening, for example, substantially fully retracted. In some embodiments, the incision or body opening is not fully retracted, and is, instead, only partially retracted, which permits a degree of motion for the retractor **6100**

- 20 -

associated cover **5500** (FIG. 5) relative to the incision or opening. Moreover, when the outer ring **6120** with a portion of the sleeve wrapped therearound is in contact with the exterior surface of the body wall, the outer ring **6120** of the wound retractor is noncompliant, that is, not flexible or likely to yield under the forces normally experienced during use of the wound retractor **6100**. Accordingly, embodiments of the rigid outer ring **6120** facilitate 360° atraumatic retraction of an incision or body opening. The illustrated wound retractor **6100** is a durable device that provides reliable protection of the incision or body opening during surgery.

[0075] As illustrated in FIG. 5, some embodiments of the access device **5000** comprise a cap, cover, or lid **5500** coupled to the outer ring of the retractor **5100**, which seals the retractor **5100**, for example, for maintaining pneumoperitoneum. In some embodiments, lid **5500** is removable, for example to provide access into the body cavity. Some embodiments of the lid **5500** comprise a transparent or translucent portion, thereby allowing a user to view into the body cavity without removing the lid **5500**. As will be described below, one embodiment of a lid **5500** is a gel cap. In some embodiments, a cross-sectional shape of the outer component **6112** (FIG. 6A) of the outer ring of the wound retractor is selected to reduce or prevent the lid **5500** from partial and/or incorrect coupling to the outer ring **6110** (FIG. 6A) of the wound retractor. Such cross-sectional shapes include oval and rectangular, or any other suitable cross-sectional shape that provides the desired functionality, for example, hexagonal, octagonal, and the like. Additionally, depending on the use and on surgeon preference, in some embodiments, each of the inner ring **6110** and outer ring **6120** of the wound retractor includes independently variable design configurations. For example, embodiments of the inner ring **6110** and/or the outer ring **6120** are rigid or flexible, and have footprints, cross-sectional shapes, and/or dimensions dependent on the intended use, for example, circular or oval footprints, diameters dependent on incision or orifice dimensions, or cross-sectional dimensions dependent on retraction force.

[0076] Accordingly, embodiments of the wound retractor **6100** enable a surgeon to quickly retract and protectively line a surgical incision or natural body orifice, while easily accommodating variations in the body wall thicknesses between patients. In addition, embodiments of the device **6100** effectively seal around the interior and exterior of the

incision or orifice, and allow a sealing cap **5500** (FIG. 5) to be coupled thereto, thereby effectively sealing the body cavity and enabling a surgical procedure to be performed.

[0077] FIG. 8A is a partial side cross-sectional view of another embodiment of a retractor **8100** comprising an inner ring **8110**, an outer ring **8120**, and a flexible sleeve **8130**. A tether **8140** comprises a distal end **8142** secured to the inner ring **8110**. A proximal end **8144** of the tether extends through the sleeve **8130** and the outer ring **8120**, terminating in an optional handle **8146** in the illustrated embodiment. As illustrated in FIG. 8B, in an embodiment of a method for removing the retractor **8100** from a patient, pulling the handle **8146** of the tether draws the inner ring **8110** towards the outer ring **8120**. Further pulling the tether **8140** causes the inner ring **8110** to contact the outer ring **8120**, thereby deforming the inner ring **8110** as it passes through the outer ring **8120**. Embodiments of tethers are also disclosed in U.S. Patent Publication No. 2006/0149137 A1, the disclosure of which is incorporated by reference.

[0078] In some embodiments, the tether comprises a fiber, a woven cord, or a braided cord. In some embodiments, the tether **8140** comprises a tube. In some embodiments, the tether **8140** comprises a cord and a tube, for example, disposed within the tube, integrated within a wall of the tube, or secured to an outer wall of the tube. The tether **8140** comprises any suitable material, for example, at least one of a suture material, polymer resin, polyamide (NYLON®, DACRON®), polyester, silk, polyethylene, polyether block amide (PEBAX®), and the like.

[0079] In some embodiments, the tether **8140** is releasably secured to an inner wall of the sleeve **8130** such that when the outer ring **8120** is rotated about its annular axis while retracting, the tether **8140** is released from an edge of the sleeve **8130** proximal to the outer ring **8120** as the sleeve **8130** winds therearound.

[0080] In some embodiments in which the tether **8140** comprises a tube, the tether further comprises at least one fluid opening through the wall of the tube disposed at or near the distal end **8142** thereof. In some of these embodiments, the tether **8140** is also useful as a gas inlet/outlet, for example, for an insufflation gas. In some procedures, the body wall creates a constriction in the sleeve **8130** when the retractor **8100** is in use. This constriction can restrict gas exchange and/or movement between a volume below the constriction and a

- 22 -

volume above the constriction. In particular, the fluid opening at the distal end **8142** of the tether is below the constriction, while a fluid opening disposed at or near the outer ring **8120** or cap or cover **5500** (FIG. 5) is above the constriction. Positioning the fluid opening in the tether **8140** below the constriction facilitates gas injection into and/or venting from the volume below the constriction, and is particularly useful for venting vapors and/or smoke from the body cavity, which are generated, for example, in electrosurgical procedures such as cutting and cauterizing. In some embodiments, a fluid opening at the proximal end **8142** of the tubular tether extends through the gel cap and is fluidly connected to a gas source and/or vacuum source. In other embodiments, the fluid opening at the proximal end **8142** of the tether is fluidly coupled to another gas fitting, for example, disposed on the interior of the gel cap.

**[0081]** FIG. 9A is a side view of an embodiment of an insertion tool **9700** for inserting an inner ring **9110** of a retractor **9100**. The insertion tool comprises an obturator **9710** and a cannula **9720**. The obturator **9710** comprises an elongate, cylindrical body **9712** comprising a proximal end and a distal end, a handle **9714** at the proximal end of the body **9712**, and a hook **9716** at the distal end of the body. The cannula **9720** comprises a tubular body **9722** comprising a proximal end and a distal end, and handle **9724** at the proximal end. The tubular body **9722** is open at both the proximal and distal ends, and is dimensioned to slidably receive the cylindrical body **9712** of the obturator therein. The tubular body **9722** is also dimensioned to receive at least a portion of the inner ring **9110** of a retractor. Other embodiments of insertion and extraction tools are described in U.S. Patent Publication No. 2006/0149137 A1, the disclosure of which is incorporated by reference.

**[0082]** As illustrated in FIG. 9A, the inner ring **9110** is loaded into the distal end of the tubular body **9722** of the cannula, which is then inserted through an opening or incision **9752** in a body wall **9750**. The distal end of the obturator **9710** is inserted into and advanced through the proximal end of the tubular body **9722**, thereby urging the inner ring **9110** out of the tubular body **9722** and into the body cavity **9754**.

**[0083]** FIG. 9B illustrates another embodiment of a method for inserting an inner ring **9110** into a body cavity **9754** through an opening **9752** without using the cannula **9720**. In this embodiment, a portion of the inner ring **9110** is captured in the hook **9716** disposed at

the distal end of the obturator. The distal end of the obturator **9710** and the captured inner ring **9110** are urged through the opening **9752** and into the body cavity **9754**.

[0084] FIG. **9C** illustrates an embodiment of a method for removing the inner ring **9110** using the hook **9716** of the obturator. The distal end of the obturator **9710** is inserted through the opening **9752** in the body wall between the sleeve **9130** and the body wall **9750**. After capturing the inner ring **9110** with the hook **9716**, the obturator **9710** and inner ring **9110** are withdrawn through the opening **9752**.

[0085] FIG. **10A** illustrates in perspective an embodiment of a cap or cover **10500**, which is a surgical access device that seals the opening between the body cavity and the area outside the body cavity while providing access into the body cavity from outside the body cavity. More particularly, the illustrated cap **10500** releasably and sealingly couples to the outer ring **6120** (FIG. **6A**) of the wound retractor. The cap **10500** comprises a cap ring **10510** dimensioned and configured for coupling to the outer ring **6120** of the wound retractor and a pad **10530** coupled to the cap ring **10510**. Embodiments of the cap **10500** provide an artificial body wall with consistent properties compared with a natural body wall, for example, thickness, compliance, rigidity, uniformity, and the like.

[0086] The illustrated cap or cover **10500** is substantially circular. In other embodiment, the gel cap **10500** has another shape or footprint, for example, oval, elliptical, parabolic, square, rectangular, or another suitable curved or polygonal shape. In some embodiments, the outer ring **6120** of the retractor and cap ring **10510** of the cap have the same general shape or footprint. In other embodiments, the outer ring **6120** of the retractor and cap ring **10501** of the cap have substantially different shapes, for example, a generally circular outer ring **6120** and an oval cap ring **10510**. In these embodiments, the outer ring **6120** is distorted or reshaped for coupling to the cap ring **10510**, for example, by compressing opposed sides of the outer ring **6120**. Non-circular shapes are useful, for example, for procedures in which space is limited. As discussed above, retracting a long, straight incision using an oval or elongated retractor requires less force than a similar procedure using a circular retractor.

[0087] In some embodiments, the pad **10530** comprises a gel. In such embodiments, the pad **10530** is referred to as a "gel pad" and the cap **10500** is referred to as a

“gel cap”. Descriptions of gel pads and gel caps generally apply to embodiments in which the pad **10530** does not comprise gel unless otherwise specified. In some embodiments, the gel pad **10530** does not comprise any preformed access channels therethrough, for example, for instrument access. Instruments may be inserted directly through the gel pad **10530**, puncturing the gel pad **10530**, and thereby creating access channels or portions in the gel pad **10530**. Each access portion forms an instrument seal in the presence of an instrument inserted therethrough and a zero seal in the absence of an instrument inserted therethrough. The gel provides a gas tight seal around a variety of shapes and sizes of instruments inserted therethrough. Some embodiments of the gel pad **10530** also provide trocar access directly therethrough, which also provide instrument access into the body cavity. Embodiments of the gel pad **10530** have a working diameter of from about 40 mm to about 120 mm, which is the diameter of a portion of the gel pad **10530** through which instruments and/or trocars may be inserted. Embodiments of the gel cap **10500** are typically from about 10 mm to 50 mm wider than the working diameter.

[0088] Accordingly, embodiments of the gel cap **10500** maintain pneumoperitoneum during multiple instrument exchanges and substantially prevent unintentional loss of pneumoperitoneum. Embodiments of the gel cap **10500** also provide substantially continuous access and visibility during surgery. Embodiments of the gel cap **10500** have a small profile for use in procedures with limited surgical space.

[0089] In some embodiments, the gel is an ultragel, which is characterized by an ultimate elongation greater than about 1000 percent and a durometer less than about 5 Shore A. Some embodiments of the ultragel comprising KRATON® and mineral oil exhibit an ultimate elongation exceeding about 1500 percent and improved sealing properties, for example, sealing with instruments of a wider size range than other seal materials. In some embodiments, the seals comprising ultragels also form zero seals when the instrument is removed therefrom. Accordingly, in some embodiments of seals comprising ultragels, a single seal is acts as both the instrument seal as well as the zero seal.

[0090] Some embodiments of the cap ring **10510** comprise a substantially cylindrical ring comprising a proximal portion, a distal portion, and a longitudinal axis extending from the proximal portion to distal portions. In other embodiments, the cap ring

**10510** has another shape or footprint, for example, oval. As best seen in FIG. **10B**, which is a bottom view of a cap ring **10510**, in the illustrated embodiment, the proximal portion of the cap ring **10510** comprises a plurality of apertures **10512** distributed about the periphery thereof. The apertures **10512** extend through a wall **10514** at the proximal portion of the cap ring. In other embodiments, the apertures **10512** are disposed in at least one member extending either longitudinally inward or longitudinally outward from the wall **10514** of the cap ring. The gel pad **10530** is disposed at the proximal portion of the cap ring **10510** in the illustrated embodiment, with portions of the gel pad **10530** extending through the apertures **10512**, thereby creating an interlocking structure between the cap ring **10510** and the gel pad **10530**, mechanically locking the cap ring **10510** and the gel pad **10530** together.

[0091] The distal portion of the cap ring **10510** is substantially cylindrical in the illustrated embodiment, and is dimensioned and configured to receive the outer ring **6120** (FIG. **6A**) of the wound retractor. The cap ring **10510** comprises a latch mechanism **10516** that removably couples the cap ring **10510** to the outer ring **6120**. Those skilled in the art will understand that other mechanisms are also useful for coupling the cap ring **10510** to the outer ring **6120** of the wound retractor, for example, protruding lips, levers, clips, latches, tongues, grooves, screw threads, bayonet mounts, screws, friction fittings, compression fitting, snap caps, and the like. In the illustrated embodiment, when the outer ring **6120** of the wound retractor is received in the distal portion of the cap ring **10510**, the outer ring **6120** of the wound retractor contacts and embeds within a portion of the gel pad **10530** disposed at the distal portion of the cap ring **10510**, thereby displacing a portion of the gel, and forming a seal between the gel pad **10530**, and the outer ring **6120** and sleeve **6130** of the wound retractor. Thus, the distal portion of the gel pad **10530** is in juxtaposition with the incision or body orifice. In other embodiments, the cap ring **10510** is permanently coupled or fixed to the outer ring **6120**.

[0092] The cap ring **10510** in some embodiments comprises a polymer. Examples of suitable polymers include, at least one of polyethylene (PE), low density polyethylene (LDPE), high density polyethylene (HDPE), ultra high molecular weight polyethylene (UHMWPE), polycarbonate, thermoplastic elastomers (DYNAFLEX®, GLS Corp.; KRATON®, Kraton Polymers), polyphenylene oxide (PPO), polystyrene, and the like. The

polymer component of the cap ring is fabricated by any suitable method, including injection molding, melt casting, blow molding, and the like.

[0093] Some embodiments of a process in which the gel pad **10530** is cast in the cap ring **10510** include steps performed at temperatures above about 130 °C over several hours, for example, from about three (3) to about four (4) hours. Accordingly, in some of these embodiments, the cap ring **10510** does not deform under these conditions.

[0094] Some embodiments of the gel pad **10530** comprise an elastomeric gel. Examples of such gels are described in U.S. Patent Application No. 10/381,220, filed March 20, 2003, the disclosure of which is hereby incorporated by reference as if set forth in full herein. Embodiments of the gel are prepared by mixing at least one triblock copolymer with a solvent that dissolves the midblocks of the triblock copolymer. The mixture is typically a slurry. The endblocks typically comprise a thermoplastic material, such as styrene, while the midblocks typically comprise a thermoset elastomer such as, ethylene/butylene, isoprene, or butadiene. Examples of the triblock copolymer include styrene-ethylene/butylene-styrene (SEBS), styrene-isoprene-styrene (SIS), and styrene-butadiene-styrene (SBS). In some embodiments, the solvent is an oil, for example, mineral oil. Upon heating a mixture or slurry of the triblock copolymer, the midblocks dissolve in the mineral oil, thereby forming a network of the insoluble endblocks. The resulting network has enhanced elastomeric properties compared with the parent copolymer. In some embodiments, the triblock copolymer used is KRATON® G1651, which has a styrene to rubber ratio of 33/67. Once formed, the gel is substantially permanent and, by the nature of the endblocks, processable as a thermoplastic elastomer henceforward. The mixture or slurry has a minimum temperature at which it becomes a gel, which is referred to as the minimum gelling temperature (MGT). This temperature typically corresponds to the glass transition temperature of the thermoplastic endblock plus a few degrees. For example, the MGT for a mixture of KRATON® G1651 and mineral oil is about 120 °C. When the slurry reaches the MGT and the transformation to a gel state takes place, the gel becomes more transparent, thereby providing a visual endpoint confirming the complete transformation of the slurry to the gel state, whereupon the gel may be cooled. Some embodiments of the gel comprise a diblock copolymer, either instead of or in addition to the triblock copolymer. Embodiments of the

diblock copolymer comprise a thermoplastic first endblock, for example, styrene, and a thermoset elastomeric second endblock, for example, ethylene/butylene, isoprene, or butadiene. An example of a suitable diblock copolymer is styrene-ethylene/butylene (SEB).

**[0095]** For a given mass of slurry to form a complete gel, the entire mass of the slurry is heated to or above the MGT and held at or above the MGT for a sufficient time for the end blocks to form a network or matrix of interconnections. The slurry will continue to form a gel at temperatures between the MGT and temperatures at which the components of the slurry/gel begin to decompose and/or oxidize. For example, when the slurry/gel is heated at temperatures above 250 °C, the mineral oil in the slurry/gel will begin to be volatile and oxidize. Oxidizing may cause the gel to turn brown and become oily.

**[0096]** The speed at which a given volume of slurry forms a gel depends on the speed with which the entire mass of slurry reaches the MGT. Also, at temperatures higher than the MGT, the end block networks distribute and form more rapidly, thereby speeding the gel formation.

**[0097]** The various base gel formulas may also be mixed or alloyed with one another to provide gels with a variety of intermediate properties. For example, KRATON® G1701X is a mixture of seventy percent (70%) SEB and thirty percent (30%) SEBS, with an overall styrene to rubber ratio of 28/72. Those skilled in the art will appreciate that an almost unlimited number of combinations, alloys, and styrene to rubber ratios can be formulated, each providing and embodiment exhibiting one or more advantages, for example, low durometer, high elongation, and good tear strength.

**[0098]** Some embodiments of the gel material further comprise a polymer that, with a foaming agent, improves the sealing properties of the gel, for example, silicone, soft urethanes, and even harder plastics. Examples of suitable silicones include those used for electronic encapsulation. Examples of suitable harder plastics include polyvinylchloride (PVC), isoprene, KRATON® neat, and other KRATON®/oil mixtures. In the KRATON®/oil mixture, suitable oils include vegetable oils, petroleum oils, and silicone oils, as well as mineral oil.

**[0099]** Some embodiments of the gel comprise one or more additives that provide one or more desirable properties, for example, at least one of enhanced lubricity, improved

appearance, and wound protection. Additives are incorporated directly into the gel and/or applied as a surface treatment. In some embodiments, other compounds are added to the gel to modify its physical properties and/or to assist in subsequent modification of the surface by providing bonding sites and/or surface charges. Additionally, oil-based colorants are added to the slurry to create gels of different colors in some embodiments.

[00100] Some embodiments of the gel pad **10530** comprise a layer of polyethylene on at least one surface. Polyethylene is dissolved in mineral oil and the solution applied to one or more surfaces of the gel pad **10530**. The mineral oil does not evaporate, but instead, absorbs into the gel pad over time, leaving behind the polyethylene as a layer on the surface of the gel pad.

[00101] In some embodiments, the triblock copolymer/solvent mixture/slurry used to manufacture the gel pad **10530** comprises about ninety percent (90%) by weight of mineral oil and about ten percent (10%) by weight of KRATON® G1651. From a thermodynamic standpoint, this mixture behaves similarly to mineral oil. Because mineral oil has a relatively high heat capacity, transforming 0.45 kg (1 pound) of the slurry into a homogenous gel at about 130 °C may take from about three (3) to about four (4) hours. Once formed, the gel can be cooled as quickly as practicable with no apparent deleterious effects on the gel. In some embodiments, the gel is cooled by cold-water immersion. In other embodiments, the gel is air-cooled. Those skilled in the art will recognize that other cooling techniques are used in other embodiments.

[00102] Certain properties of the KRATON®/oil gel will vary with the weight ratio of the components. In general, a higher proportion of mineral oil results in a softer gel, while a higher proportion of KRATON® results in a firmer gel. A too-soft gel exhibits excessive tenting or doming of the gel cap **10500** during surgery when a patient's body cavity is insufflated. Some embodiments of gels that are too soft also do provide an adequate instrument seal and/or zero seal. The gel should be sufficiently soft to provide an adequate seal both in the presence of an instrument and in the absence of an instrument, however.

[00103] On prolonged or extended sitting or standing, the copolymer, such as KRATON®, and the solvent, such as mineral oil, in the slurry may separate. The slurry may be mixed to greater homogeneity, for example, with a high shear mixer. Mixing the slurry

may introduce or add air to the slurry, however. To remove air from the slurry, the slurry may be degassed. In some embodiments, the slurry is degassed under a vacuum, for example, within a vacuum chamber. In some embodiments, the applied vacuum is about 0.79 meters (about 29.9 inches) of mercury, or about one (1) atmosphere. Optionally, stirring or mixing the slurry under vacuum facilitates removal of the air. During degassing under vacuum, the slurry typically expands, then bubbles, and then reduces in volume. The vacuum is typically discontinued when the bubbling substantially ceases. Degassing the slurry in a vacuum chamber reduces the volume of the slurry by about ten percent (10%). Degassing the slurry also reduces oxidation of the finished gel in some embodiments.

**[00104]** Degassing the slurry tends to result in a firmer gel. A gel made from a degassed slurry comprising about 91.6% by weight of mineral oil and about 8.4% by weight of KRATON® G1651, an eleven-to-one ratio, has about the same firmness as a gel made from a slurry that is not degassed and that comprises about ninety percent (90%) by weight of mineral oil and about ten percent (10%) by weight of KRATON® G1651, a nine-to-one ratio.

**[00105]** Because mineral oil typically has a lower density than KRATON®, the two components will separate after mixing, with the less dense mineral oil rising to the top of the container. This phase separation typically occurs when transforming a static slurry into a gel over several hours. Consequently, the resulting gel is non-homogeneous, with a higher concentration of mineral oil at the top and a lower concentration at the bottom. The speed of separation is a function of the depth or head height of the slurry being heated. Factors relevant to the relative homogeneity of the gel include the mass of slurry, the head height, the temperature at which the gel sets, and the speed at which the energy is transferred to the gel.

**[00106]** The gel pad **10530** or gel cap **10500** are gamma sterilized in some embodiments, which is relatively and/or comparatively simpler to qualify compared with other sterilization process, for example, versus ethylene oxide. Gamma sterilization can cause large bubbles to form in the gel pad, however, which are cosmetic and/or aesthetic issues in the sterilized devices. Because bubbles typically comprise greater than ninety-nine percent (99%) room air, the dissolved air is advantageously removed from the slurry prior to transforming the slurry into a gel. For example, the slurry may be degassed under vacuum, as described above, then gelled by heating. Some bubbles may still form in the gel during

gamma sterilization, but typically disappear over a period of from about twenty-four (24) hours to about seventy-two (72) hours. Typically, mineral oil at room temperature has about ten percent (10%) dissolved gas. As discussed above, removing air from the gel makes the gel firmer. This effect is counterbalanced by a softening of the gel by the gamma radiation during gamma sterilization, however.

[00107] In some embodiments in which the gel pad **10530** is gamma sterilized, the gel comprises about ninety percent (90%) mineral oil by weight and about ten percent (10%) KRATON® by weight. As stated above, degassing the slurry makes the gel firmer. The counteracting softening by the gamma radiation, however, results in a gel with substantially the same firmness as a gel comprising about ninety percent (90%) mineral oil by weight and about ten percent (10%) KRATON® by weight that is not degassed and gamma sterilized.

[00108] In some embodiments, the gel pad **10530** is coupled to, attached to, formed with, or integrated with the cap ring **10510** to provide a gas-tight seal between the cap ring **10510** and the sleeve **6130** (FIG. 6A). The gel pad **10530** covers and seals the entire opening in the cap ring **10510**, as well as covering substantially the entire wound or orifice opening. As stated above, the gel pad **10530** provides a gas tight seal around a variety of shapes and sizes of instruments inserted therethrough.

[00109] Embodiments in which a gel pad support structure of the cap ring **10510** comprises a thermoplastic elastomer, for example, DYNAFLEX® or KRATON®, and the gel pad **10530** comprises a similar thermoplastic elastomer, for example, KRATON®, exhibit improved adhesion between the gel pad **10530** and the cap ring **10510**. The polystyrene component of KRATON® in the gel pad **10530** improves adhesion with polyphenylene oxide (PPO), polystyrene, and other similar polymers.

[00110] In some embodiments of cap rings **10510** comprising polycarbonate, the polycarbonate component of the cap ring **10510** does not bond with the gel pad **10530** at 130 °C, which is a typical manufacturing temperature for a gel pad **10530** comprising KRATON®. Raising the temperature to about 150 °C for a few minutes during casting, however, bonds the gel pad **10530** to the cap ring **10510**. It is believed that heating the gel pad **10530** and cap ring **10510** to a temperature at which both the polystyrene component of the gel and the polycarbonate are simultaneously above their melt points allows bonds to

form therebetween. In other embodiments, the uncured gel and the cap ring **10510** are heated to near or at the glass transition temperature of the polycarbonate in the cap ring **10510**, thereby bonding the gel pad **10530** to the cap ring **10510**.

[00111] In some embodiments, the gel comprises mineral oil and the cap ring **10510** comprises a polymer that dissolves in mineral oil under the manufacturing conditions, for example, polyethylene (PE), low density polyethylene (LDPE), high density polyethylene (HDPE), and ultra high molecular weight polyethylene (UHMWPE). Using polyethylene (PE) as an example, PE has a higher molecular weight than mineral oil and dissolves in mineral oil at the temperatures used to cast the gel pad **10530**. As such, as a portion of the PE in the cap ring **10510** dissolves in the mineral oil in the gel pad **10530** at the processing temperatures, for example, above about 130 °C, a bond between the PE in the cap ring **10510** and gel pad **10530** is formed.

[00112] In an embodiment of a method for manufacturing a gel cap, the cap ring **10510** is placed into a mold that together with the cap ring **10510** includes a negative space in the desired shape of the gel pad and uncured gel is added to the mold. Sufficient uncured gel is then added to the mold to cover and fill the apertures **10512**. The uncured gel flows through, fills, and remains within the apertures. Also, in some embodiments, the mold is filled with sufficient uncured gel to extend into the distal portion of the cap ring **10510**. After the gel cures, the gel in the apertures connects and couples the gel on a first side of each aperture **10512** to the gel on a second side of the aperture, thereby mechanically locking the gel pad **10530** to the cap ring **10510**.

[00113] Some embodiments include another method for coupling the gel pad **10530** to the cap ring **10510**, either in addition to or instead of the mechanical interlocking discussed above. Such methods are useful, for example, for coupling separately formed gel pads or gel slugs **10530** and cap rings **10510**. Some embodiments use a glue or adhesive to couple the gel pad **10530** to the cap ring **10510**, for example, cyanoacrylate (SUPERGLUE® or KRAZY GLUE®). The glue is believed to bond to either the rubber or the styrene component of the triblock copolymer with a bond is frequently stronger than the gel material itself. Some embodiments use solvent welding in which a solvent dissolves a plastic in the cap ring **10510** and the polystyrene in the gel pad **10530**. The solvent is applied to the gel pad

**10530** and cap ring **10510** by any suitable method, for example, by spraying and/or by dipping. In effect, the solvent melts both the plastic of the cap ring **10510** as well as the polystyrene in the gel pad **10530**, thereby forming a bond between the two, which remains after the solvent evaporates.

[00114] In an embodiment for manufacturing a gel cap **10500**, the gel pad **10530** is cast into the cap ring **10510** to form the gel cap **10500**. The cap ring **10510** is positioned in or placed into a mold cavity of a casting mold. Embodiments of the mold cavity include support for the annular walls of the cap ring **10510**. Embodiments of the mold comprise a material with sufficient heat dissipation properties, for example, at least one of aluminum, copper, and brass. Those skilled in the art will recognize that other mold materials with lower heat dissipation properties will produce acceptable parts in some embodiments. Furthermore, some embodiments of the mold comprise active cooling elements, for examples, channels through which coolants are pumped.

[00115] The mold cavity and cap ring **10510** assembly is then filled with a desired amount of the triblock copolymer/mineral oil slurry such that the slurry contacts the cap ring **10510**. In some embodiments, the slurry is preheated, for example, to about 52 °C (125 °F), which facilitates a complete filling of the mold cavity by the slurry, thereby reducing the probability of voids in the gel. Preheating the slurry to a temperature below the MGT reduces the viscosity of the slurry and allows the slurry to flow more easily. As stated above, some embodiments of the slurry are degassed in a vacuum before casting. In some embodiments, the slurry is also degassed after it is filled in the mold cavity to remove any air that may have been introduced during the filling of the mold cavity, as well as to facilitate flow of the slurry into voids in the mold. The mold, cap ring, and slurry are heated, for example, in an oven, until the slurry reaches a temperature of about 150 °C. As stated above, the slurry turns into gel at about 120 °C; however, at about 150 °C, the gel bonds to a polycarbonate cap ring **10510**. Depending on the material used in the cap ring **10510**, bonding may take place at a temperature other than about 150 °C. In embodiments in which the cap ring **10510** is comprises a material with a lower melting point than the MGT, for example 120 °C, the gel pad **10530** is molded separately as a gel slug, which is then bonded to the cap ring **10510** as discussed above.

[00116] When the transformation of the slurry into a gel is complete, for example, when the temperature of the gel pad reaches about 150 °C, the gel cap **10500** is cooled, for example, by air-cooling, cold-water immersion, or another suitable method. At 150 °C the gel pad **10530** is soft and easily distorted. Distortions in the gel pad **10530** present during cooling would be set after cooling. Accordingly, in some embodiments, the gel cap **10500** is cooled within the mold, thereby reducing the likelihood of distorting the gel pad **10530**. Factors affecting the cooling time include the size and configuration of the mold, the quantity of gel, temperature and quantity of cooling medium, the properties of the cooling medium, and the mold material. As an example, the cooling time for a particular gel cap **10500** may be about two (2) hours for air cooling and about fifteen (15) minutes for water cooling. Whether cooling with air or water, the final properties of the gel are substantially the same. The gel cap **10500** is typically cooled to about ambient room temperature, but may be cooled to a lower temperature if desired. At about 0 °C, the gel hardens, which is useful, for example, in secondary operations such as when coupling separately manufactured gel pads **10530** and cap rings **10510**. The gel cap **10500** may be removed from the mold at any time after the gel has set.

[00117] When removed from the mold, the gel pad **10530** typically has a tacky surface. Coating the gel pad **10530** with a powder, such as cornstarch, substantially reduces or eliminates the tackiness of the cured gel pad **10530**.

[00118] As stated above, in some embodiments, the gel pad **10530** is molded separately from the cap ring **10510**, and coupled to the cap ring **10510** in a secondary operation, for example, bonding. In some embodiments, the gel pad **10530** is molded as a gel slug with an outer perimeter smaller than the perimeter of the inner cylindrical wall of the cap ring **10510** and a height greater than the height of the cap ring **10510**. Because the gel pad **10530** is molded separate from the cap ring **10510**, the slurry need only be heated to the MGT, for example, about 120 °C, to complete the transformation of the slurry into a gel, whereupon the gel becomes substantially transparent. As discussed above, the gel slug may be cooled, for example, to about 0 °C, then placed within the inner cylindrical wall of the cap ring **10510**.

[00119] In some embodiments, the gel slug is coupled to the cap ring **10510** through compression molding, in which the gel slug is compressed longitudinally, thereby expanding the outer perimeter of the gel slug and compressing the gel slug against the inner cylindrical wall of the cap ring **10510**. The compressed gel slug and cap ring **10510** are then heated to a sufficient temperature for the polystyrene in the gel and the polymer of the cap ring **10510** to form bonds therebetween. Molding the gel slug separately from the cap ring **10510** followed by heat bonding the gel slug to the cap ring is especially useful in embodiments in which the cap ring **10510** comprises a material with a melting temperature lower than the MGT of the gel. In such situations, the gel slug can be molded separately and heat bonded to the cap ring **10510** without melting the cap ring **10510**.

[00120] A embodiment of a method for retracting an incision or body orifice using the retractor **6100** is discussed in detail above. The method results in the outer ring **6120** of the retractor with a portion of the sleeve **6130** wrapped therearound substantially in contact with the exterior surface of the body wall. The gel cap **10510** is then coupled to the outer ring **6120** of the wound retractor, thereby sealing the opening between the body cavity and the area outside the body cavity and allowing the surgeon to insufflate the body cavity.

[00121] As discussed above, embodiments of the gel cap **10500** comprise no preformed access channels in the gel pad **10530**. In use, instruments may be inserted directly through the gel pad **10530**, thereby creating access channels through the gel pad **10530**. Each access channel created in the gel cap forms an instrument seal in the presence of an instrument passing therethrough because the gel provides a gas tight seal around a variety of shapes and sizes of instruments. When the instrument is removed from the gel pad **10530**, the channel created in the gel pad by the instrument closes to form a zero seal.

[00122] Some embodiments of the gel pad **10530**, however, are damaged by repeated insertion and removal of instruments through an access channel, for example, exhibiting shredding, flaking, or the like. The damage can degrade the instrument seal or the zero seal of the affected access channel. Shreds or particles of the damaged gel can also fall into the body cavity. Accordingly, some embodiments use access devices such as trocars inserted through the gel pad **10530** for instrument access, in particular, where an access channel experiences repeated instrument manipulation, for example, insertion, removal,

advancement, retraction, rotation and/or other manipulation. Each trocar inserted through the gel pad **10530** permits repeated introduction, removal, and/or manipulation of instruments therethrough without damaging the gel. Because the trocar itself is typically not extensively manipulated during a procedure, the access channel through which the trocar extends is not subject to damage, thereby maintaining the integrity of the gel pad **10530**. Embodiments of the trocar are designed to withstand extensive instrument manipulation without failure under ordinary conditions.

[00123] Because the gel cap **10500** initially comprises no access channels, the surgeon is at liberty to determine the placement of instruments therethrough. Moreover, the surgeon has unlimited flexibility in the placement and repositioning of ports within the area of the gel cap **10500**, as well as the option of selecting different trocar sizes for different clinical procedures. Being detachable, the gel cap **10500** allows for the removal of large specimens. Once removed, the gel cap **10500** can be re-coupled to the outer ring **6120** of the wound retractor, thereby restoring the seal and allow the surgeon to re-insufflate the body cavity.

[00124] Moreover, embodiments of the gel are deformable without losing physical integrity, and while maintaining substantially gas tight instrument seals with any instruments extending therethrough, as well as gas tight zero seals for any access channels without any instruments extending therethrough. Accordingly, embodiments of the gel cap **10500** permit both translational or positional, and angular or pivotal “float” or degrees of freedom for the instruments passing through the gel pad **10530**. This float permits instrument motion both relative to the cap ring **10510** as well as relative to other instruments. In contrast, other single or limited port systems do not exhibit one or both translational or angular float for instruments.

[00125] FIG. **11A** is a top view of an embodiment of a gel cap **11500** comprising a plurality of access ports, seals, or sealing valves disposed in the gel pad. FIG. **11B** is a perspective top view of the gel cap **11500** mounted on a retractor. FIG. **11C** is a perspective bottom view of the gel cap **11500** mounted on a retractor. The gel cap **11500** comprises a cap ring **11510** and a gel pad **11530**, which are generally similar to the cap ring and gel pad of the embodiment described above.

[00126] The gel cap **11500** further comprises a plurality of access ports **11540**, at least a portion of which is disposed within or embedded within the gel pad **11530**. In the illustrated embodiment, the access ports **11540** have a low profile, that is, do not protrude or protrude minimally above the proximal surface of the gel pad **11530** and/or below the distal surface of the gel pad **11530**. Accordingly, the lengths of the access ports **11540** are similar to the thickness of the gel pad **11530**, which is shorter than a length of a typical trocar inserted in the gel pad **11530**, which comprises a seal assembly positioned above the gel pad **10530**, and a cannula extending through the gel pad **11530**. The reduced length of the access port **11540** allows increased angular or pivotal motion for instruments extending therethrough, and also permits the use of curved and/or angled instruments. In the illustrated embodiment, the access ports **11540** are substantially permanent or non-removable under the conditions under which the gel cap **11500** is used. Trocars can also be inserted through the gel pad **11530** if additional ports are desired.

[00127] Each port **11540** comprises longitudinal axis extending from a proximal side to a distal side of the gel pad **11530**, a first seal **11542** disposed at the proximal side of the gel pad **11530**, and a second seal **11544** disposed distal to the first seal **11542**. A sight of each of the ports or seals **11540** has an aperture through the gel pad **11530** and coincides with the longitudinal axis. In the illustrated embodiment, the first seal **11542** forms an instrument seal with an instrument extending therethrough and the second seal **11544** forms a zero seal in the absence of an instrument extending therethrough.

[00128] In the illustrated embodiment, the first seal **11542** comprises a septum seal. Each septum seal comprises an aperture **11546** therethrough that is slightly smaller than a cross-section of the smallest instrument to be inserted therethrough. The aperture **11546** of the septum seal is substantially aligned with the aperture through the gel pad and the longitudinal axis of the port **11540**. When an instrument is inserted through the aperture **11546** of the septum seal, the aperture **11546** expands and engages the outer surface of the instrument, thereby forming a seal therewith. The septum seal comprises an elastomeric material that biases the aperture against an instrument is inserted therethrough. Those skilled in the art will understand that other types of instrument seals are used in other embodiments.

[00129] In the illustrated embodiment, the second seal **11544** comprises a double-duckbill valve, which functions as a zero-closure seal that provides a zero seal in the absence of an instrument inserted therethrough. Those skilled in the art will understand that the second seal comprises another type of seal, for example, a duckbill valve, a flap valve, and the like. The double-duckbill valve comprises an elastomeric material. In some embodiments, each of the first seal **11542** and the second seal **11544** independently comprise an elastomeric material, for example, at least one of rubber, synthetic rubber, silicone, ethylene propylene diene monomer (EPDM), ethylene-propylene copolymer (EP rubber), polyisoprene, polybutadiene, polyurethane, styrene-butadiene, ethylene vinyl acetate (EVA), polychloroprene (Neoprene®), perfluorelastomer (Kalrez®), and the like

[00130] Thus, during use, the septum seal provides an instrument seal in the presence of an instrument inserted therethrough, and the duckbill valve provides a zero seal in the absence of an instrument inserted therethrough. The illustrated embodiment comprises ports or seals **11540** in the gel pad of different sizes. Each size of port **11540** sealing accommodates a different range of instrument sizes inserted therethrough. The size of a port is typically given as the diameter of the largest instrument that the port will accommodate, for example, 5 mm, 11 mm, or 12 mm. FIGS. **11D**, **11E**, and **11F** are a perspective top view, a perspective bottom view, and a side view of a thinner instrument **11550a** and a thicker instrument **11550b** inserted through a smaller port **11540a** and a larger port **11540b**, respectively, of the embodiment of the gel cap **11500** illustrated in FIGS. **11A–11C**.

[00131] FIG. **11G** is a top perspective view of an embodiment of a gel cap **11500** further comprising a fixed port position, for example, for a camera or a laparoscope. The fixed port **11560** comprises a lock mechanism **11562** that maintains the position of a camera or laparoscope inserted therethrough. In some embodiments, one of the ports **11540** further comprises a stopcock and/or gas fitting used as a gas inlet and/or outlet port for insufflating, depressurizing, and/or venting the body cavity of gas. In some embodiments, a gas inlet/outlet port is disposed on the cap ring **11510**.

[00132] FIG. **12** is a cutaway perspective view of an embodiment of an access device system **12000** comprising retractor **12100** and a cap or cover **12500**, which are similar to embodiments of retractors and gel caps described above. The retractor **12100** comprises an

inner ring **12110**, an outer ring **12120**, and a sleeve **12130** extending between the inner ring **12110** and the outer ring **12120**. In the illustrated embodiment, the cap **12500** is a gel cap comprising a proximal side, a distal side, a cap ring **12510**, and a gel pad **12530**. In the illustrated embodiment, the cap ring **12510** comprises a tubular ring dimensioned to receive the outer ring **12120** of the retractor therewithin. The distal side of the cap ring **12510** comprises an annular slot **12520**, which is sufficiently radially deformable for the outer ring **12120** to reversibly pass therethrough. Accordingly, the illustrated embodiment of the cap ring **12510** secures the cap **12500** to the outer ring **12120** with a snap or friction fit.

[00133] FIG. 13 is an exploded view of an embodiment of a trocar **13800** and optional obturator **13900**, which is a component of some embodiments of the access device system. The trocar **13800** comprises a proximal end, a distal end, and a longitudinal axis. The trocar **13800** comprises a cannula **13810** extending along the longitudinal axis. A trocar seal **13820** is disposed at the proximal end of the cannula **13810**. A retainer **13830** is disposed at the distal end of the cannula **13810**. The illustrated embodiment of the trocar **13800** does not comprise an insufflation gas inlet. Consequently, the trocar **13800** is typically used in procedures in which a body cavity is not insufflated, or in which insufflation is provided through another device. Other embodiments of trocars are disclosed in U.S. Patent Application No. 11/677,994, filed February 22, 2007, the disclosure of which is incorporated by reference.

[00134] The cannula **13810** is dimensioned to accommodate an instrument or instruments received therethrough. In some embodiments, the cannula **13810** is comparatively short because the cannula **13810** need only traverse the gel pad **10530** (FIG. 10) rather than a body wall. Accordingly, some embodiments of the cannula **13810** are not more than about 2-times longer, about 1.5-times longer, about 1.2-times longer, or about 1.1-times longer than the thickness of the gel pad. In some embodiments, the cannula **13810** is less than about 20 mm, about 10 mm, or about 5 mm longer than the thickness of the gel pad. In some embodiments, the cannula **13810** is about as long as the gel pad is thick. In other embodiments, the cannula **13810** has a different length, for example, a length typical for a cannula used for traversing a body wall. Shorter length cannula permit increased angular degrees of freedom for instruments passing therethrough. Embodiments of shorter cannula

also accommodate curved instruments. The cannula **13810** comprises any suitable biocompatible material. In some embodiments, the cannula **13810** comprises a flexible material.

[00135] The illustrated trocar seal **13820** comprises an instrument or septum seal **13822** and a zero seal **13824**. The instrument seal **13822** seals instruments passing therethrough, thereby maintaining pneumoperitoneum. The zero seal **13824** provides a seal when no instrument passes through the trocar seal **13820**. The instrument seal **13822** and zero seal **13824** are received in a housing **13826** disposed at the proximal end of the cannula **13810** and secured therein by a seal cover **13828**.

[00136] The retainer **13830** is disposed at or near the distal end of the cannula **13810**. In some embodiments, the retainer **13830** and cannula **13810** are integrated, while in other embodiments, the retainer **13830** and cannula **13810** are not integrated. In the illustrated embodiment, the proximal end of the retainer **13830** is generally flat and perpendicular to the longitudinal axis, while the distal end is tapered, narrowing toward the distal end of the cannula **13810**. The flat, proximal end of the retainer **13830** reduces the likelihood of accidental or inadvertent removal of the trocar **13800** from the gel pad. The tapered end of the retainer **13830** facilitates insertion of the trocar **13800** through the gel pad, either by itself, or when assembled with the obturator **13900** extending therethrough.

[00137] In some embodiments in which the retainer **13830** and cannula **13810** are not integrated, that is, are separate components, the retainer **13830** is secured to the cannula **13810** after the cannula **13810** is inserted through the gel pad. In some embodiments, the cannula **13810** and retainer **13830** are secured mechanically, for example, using latches, screw threads, clips, lock rings, ratchets, and the like. In some embodiments, the cannula **13810** and retainer **13830** are secured adhesively. In some embodiments, the position of the retainer **13830** is adjustable, for example, to accommodate gel pads of different thicknesses. In some embodiments, the cannula **13810** and/or retainer **13830** is secured to the gel pad, for example, adhesively.

[00138] While certain embodiments have been particularly shown and described with reference to exemplary embodiments thereof, it will be understood by those of ordinary

skill in the art that various changes in form and details may be made therein without departing from the spirit and scope thereof as defined by the following claims.

WHAT IS CLAIMED IS:

1. A surgical access port adapted for performing laparoscopic surgical procedures at a single access site wherein an incision is made in the abdominal wall of a patient and the abdominal cavity is pressurized with an insufflation gas, the access port adapted to provide access to the abdominal cavity for surgical procedures while maintaining insufflation pressure in the abdominal cavity, the surgical access port comprising:

an adjustable wound retractor comprising:

a proximal ring, wherein the proximal ring is configured to be disposed proximate the outer surface of the abdominal wall of the patient and substantially surround the incision;

a retraction sheath comprising a tubular wall, a proximal portion coupled to the proximal ring during use, and a distal portion, wherein the retraction sheath is configured to be disposed through the incision and line the incision, and wherein the retraction sheath is adjustable to retract the incision; and

a distal ring coupled to the distal portion of the retraction sheath, wherein the distal ring is configured to be disposed proximate the inner surface of the abdominal wall and substantially surround the incision; and

a gel cap configured to be coupled to the proximal ring, comprising:

a cap ring, wherein the cap ring is configured to substantially surround the incision;

a gel pad disposed within the cap ring; and

a plurality of sealing valves operatively attached to the gel pad, wherein the plurality of sealing valves at least partially form a plurality of access channels through the gel pad, and wherein the plurality of sealing valves are configured to form seals with instruments extending through the sealing valves and form seals in the absence of any instruments extending through the sealing valves.

2. The surgical access port of claim 1, wherein at least a portion of at least one of the sealing valves defines an orifice.

3. The surgical access port of claim 1, wherein at least a portion of at least one of the sealing valves comprises a septum seal.

4. The surgical access port of claim 1, wherein at least a portion of at least one of the sealing valves comprises a duck bill valve.

5. The surgical access port of claim 1, wherein at least one of the sealing valves has a low profile.

6. The surgical access port of claim 1, wherein at least one of the sealing valves has a first size to accommodate an instrument of the first size, and at least another of the sealing valves has a second size to accommodate an instrument of the second size.

7. The surgical access port of claim 1, wherein at least one of the sealing valves is configured such that the sealing valve is repositionable relative to the cap ring during use.

8. The surgical access port of claim 1, wherein at least one of the sealing valves is configured such that the sealing valve is translatable relative to the cap ring during use.

9. The surgical access port of claim 1, wherein at least one of the sealing valves is configured such that the sealing valve is pivotable relative to the cap ring during use.

10. The surgical access port of claim 1, wherein at least one of the sealing valves is configured such that the sealing valve is held generally stationary relative to the cap ring during use.

11. The surgical access port of claim 1, wherein the gel cap is configured to be removably coupled to the proximal ring during use.

12. The surgical access port of claim 1, wherein the gel cap is fixed to the proximal ring.

13. The surgical access port of claim 1, wherein the proximal ring of the wound retractor is rotatable to adjustably retract the incision during use.

14. The surgical access port of claim 1, wherein the retraction sheath is stretchable to adjustably retract the incision during use.

15. The surgical access port of claim 1, additionally comprising a tether coupled to the distal ring.

16. The surgical access port of claim 1, wherein at least a portion of the distal ring has a non-circular cross section that facilitates folding the distal ring and insertion through the incision.

17. The surgical access port of claim 1, wherein the distal ring has a tear-drop-shaped cross section that facilitates folding the distal ring and insertion through the incision.

18. The surgical access port of claim 1, wherein the distal ring comprises at least one notch that facilitates folding of the distal ring and insertion through the incision.

19. A surgical access port adapted for performing a surgical procedure at an access site wherein a body cavity of a patient is pressurized with an insufflation gas, the access port adapted to provide access to the body cavity for surgical procedures while maintaining insufflation pressure in the body cavity, the surgical access port comprising:

an adjustable retractor comprising:

a proximal ring, wherein the proximal ring is configured to be disposed proximate the outer surface of the body wall of the patient;

a retraction sheath comprising a tubular wall, a proximal portion coupled to the proximal ring during use, and a distal portion, wherein the retraction sheath is configured to be disposed through an opening in the body wall of the patient, and wherein the retraction sheath is adjustable to retract the opening in the body wall; and

a distal ring coupled to the distal portion of the retraction sheath, wherein the distal ring is configured to be disposed proximate the inner surface of the body wall of the patient; and

a sealing cap configured to be coupled to the proximal ring, comprising:

a cap ring substantially surrounding a flexible material disposed within the cap ring; and

a sealing valve positioned within the cap ring and substantially surrounded by and operatively attached to the flexible material, wherein the sealing valve at least partially forms an access channel through the flexible material, and wherein the sealing valve is configured to form a seal with an

instrument extending through the sealing valve and form a seal in the absence of any instrument extending through the sealing valve.

20. The surgical access port of claim 19, wherein the flexible material comprises a gel.

21. The surgical access port of claim 19, wherein the sealing valve is repositionable relative to the cap ring during use.

22. The surgical access port of claim 19, wherein the sealing valve is translatable relative to the cap ring during use.

23. The surgical access port of claim 19, wherein the sealing valve is pivotable relative to the cap ring during use.

24. The surgical access port of claim 19, wherein the sealing cap comprises a plurality of sealing valves positioned within the cap ring and substantially surrounded by the flexible material, wherein the plurality of sealing valves at least partially form a plurality of access channels through the flexible material, and wherein the plurality of sealing valves are configured to form seals with instruments extending through the sealing valves and form seals in the absence of any instruments extending through the sealing valves.

25. The surgical access port of claim 19, additionally comprising a tether coupled to the distal ring.

26. The surgical access port of claim 19, wherein at least a portion of the distal ring has a non-circular cross section that facilitates folding the distal ring and insertion through the incision.

27. A surgical access port adapted for performing laparoscopic surgical procedures at an access site wherein an incision is made in the abdominal wall of a patient and the abdominal cavity is pressurized with an insufflation gas, the access port adapted to provide access to the abdominal cavity for surgical procedures while maintaining insufflation pressure in the abdominal cavity, the surgical access port comprising:

an adjustable wound retractor having a proximal ring, a distal ring, and a retraction sheath extending between the proximal ring and the distal ring, the proximal ring being configured to be disposed proximate the outer surface of the abdominal wall of the patient, the distal ring being configured to be disposed

proximate the inner surface of the abdominal wall of the patient, and the a retraction sheath comprising a tubular wall having a proximal portion coupled to the proximal ring during use and a distal portion coupled to the distal ring during use, wherein the retraction sheath is configured to be disposed through the incision and line the incision, and wherein the retraction sheath is adjustable to retract the incision; and

a sealing cap configured to be coupled to the proximal ring during use, the sealing cap comprising a plurality of sealing valves, wherein the plurality of sealing valves at least partially form a plurality of access channels through the sealing cap, wherein the plurality of sealing valves are configured to form seals with instruments extending through the sealing valves and form seals in the absence of any instruments extending through the sealing valves, and wherein at least one of the sealing valves is repositionable relative to at least another one of the sealing valves during use.

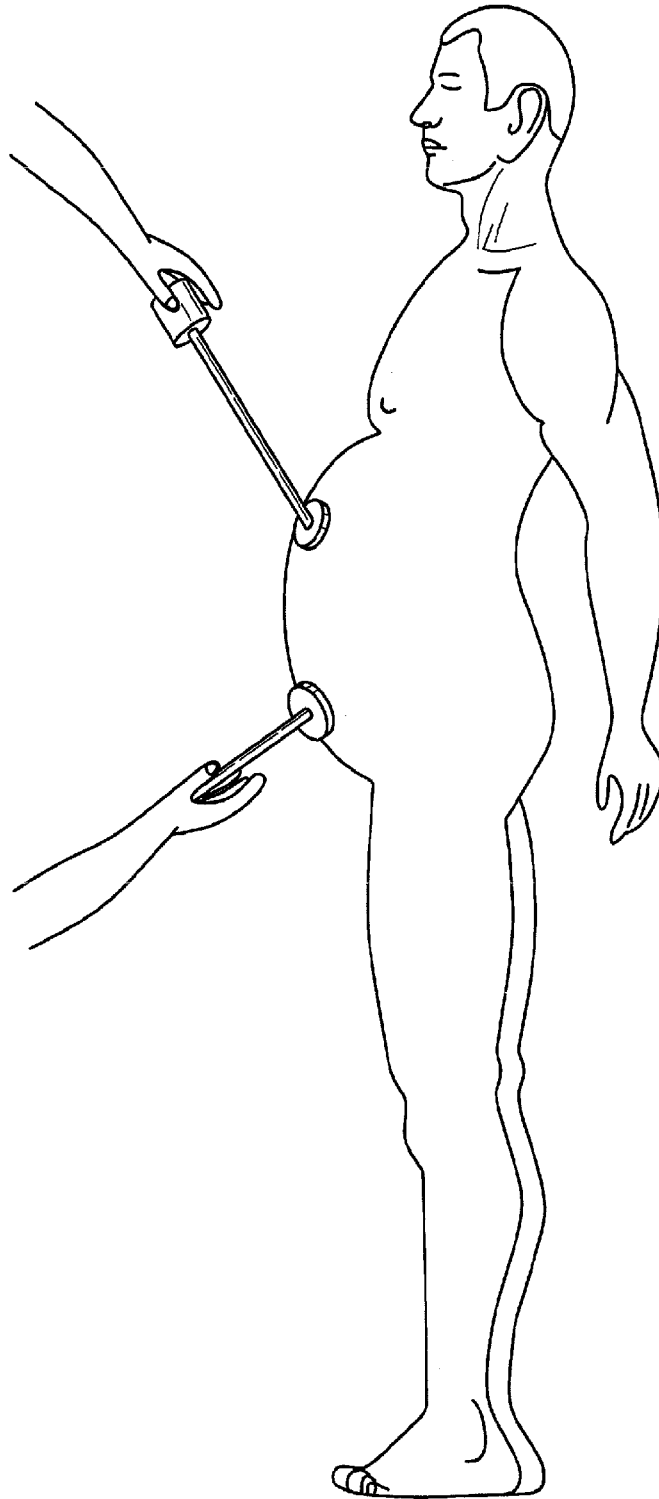
28. The surgical access port of claim 27, wherein the sealing cap comprises a gel.

29. The surgical access port of claim 27, wherein the at least one repositionable sealing valve is translatable relative to the at least another one of the sealing valves.

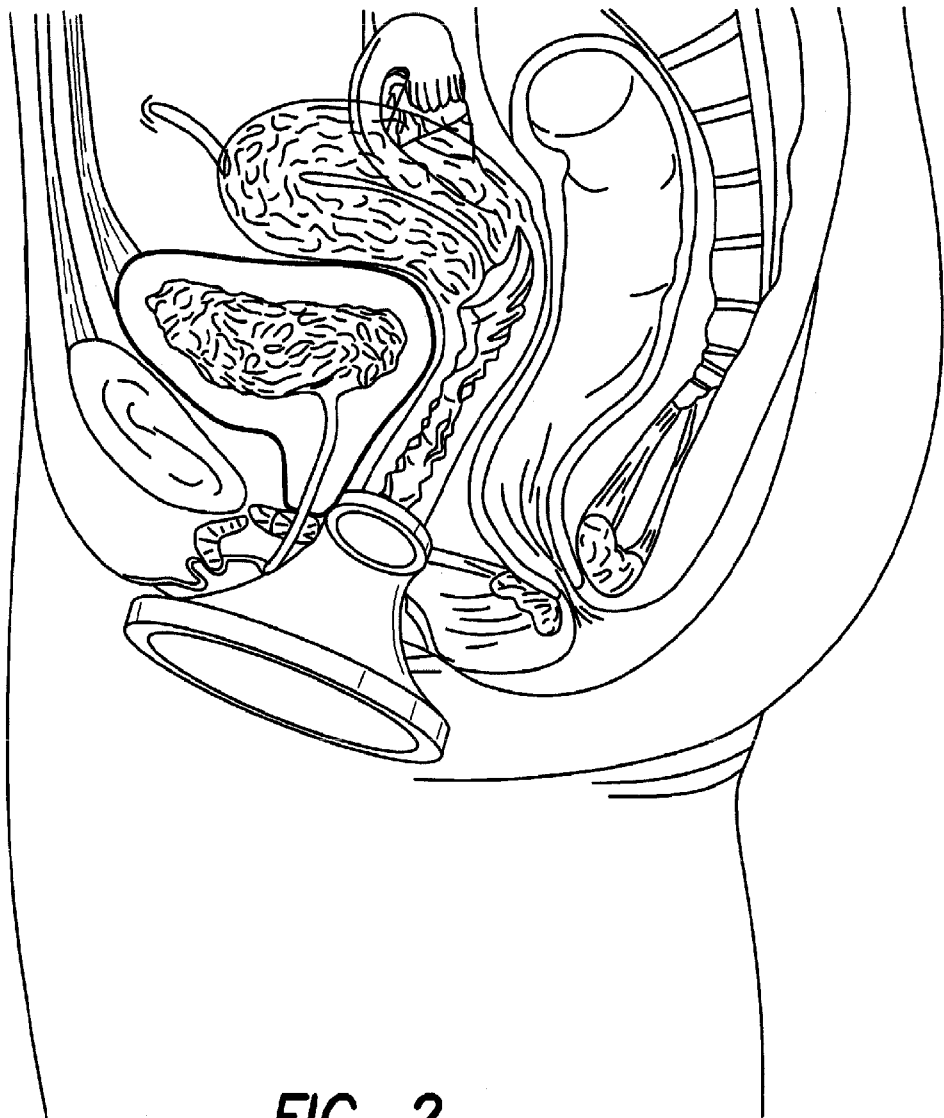
30. The surgical access port of claim 27, wherein the at least one repositionable sealing valve is pivotable relative to the at least another one of the sealing valves.

31. The surgical access port of claim 27, additionally comprising a tether coupled to the distal ring.

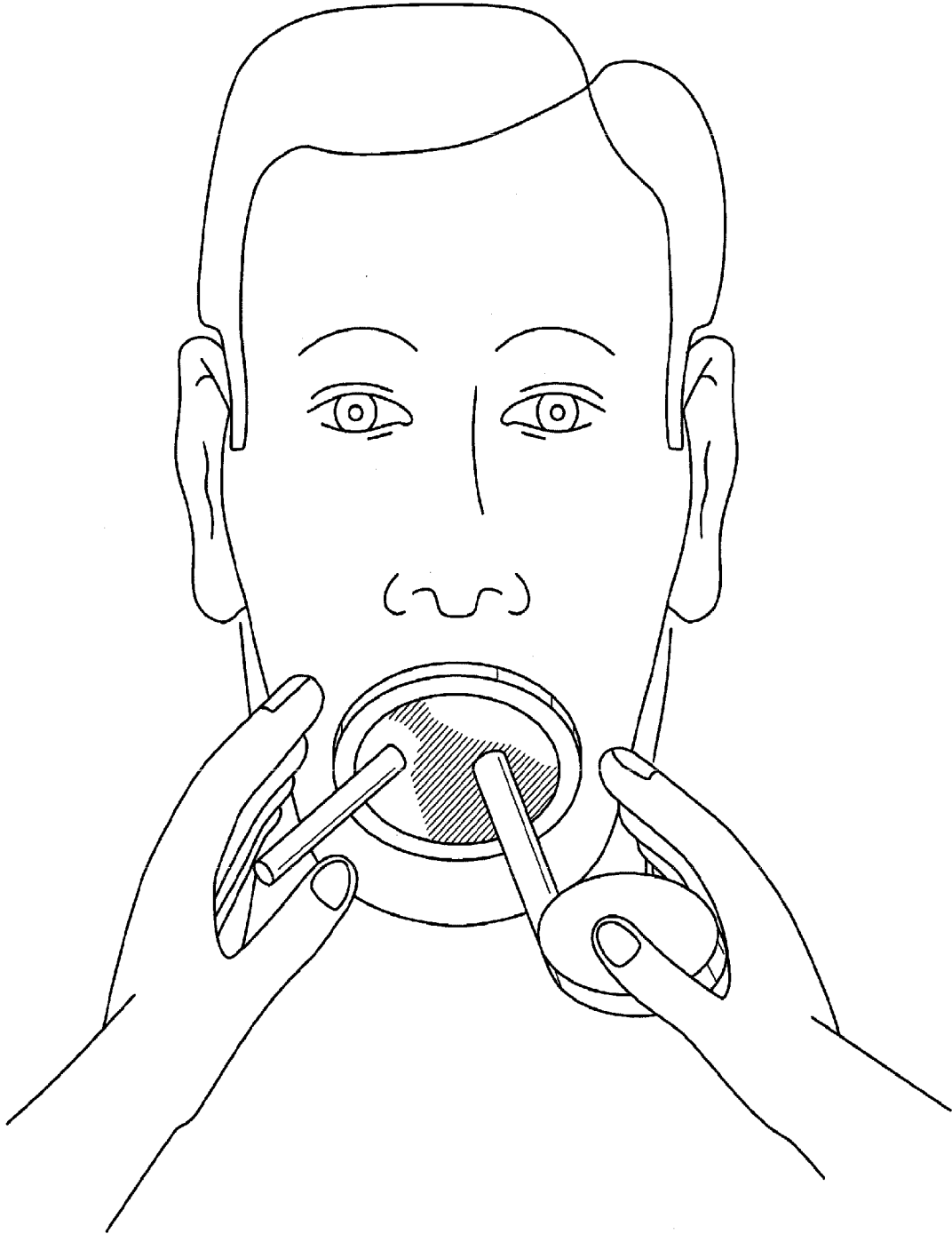
32. The surgical access port of claim 27, wherein at least a portion of the distal ring has a non-circular cross section that facilitates folding the distal ring and insertion through the incision.



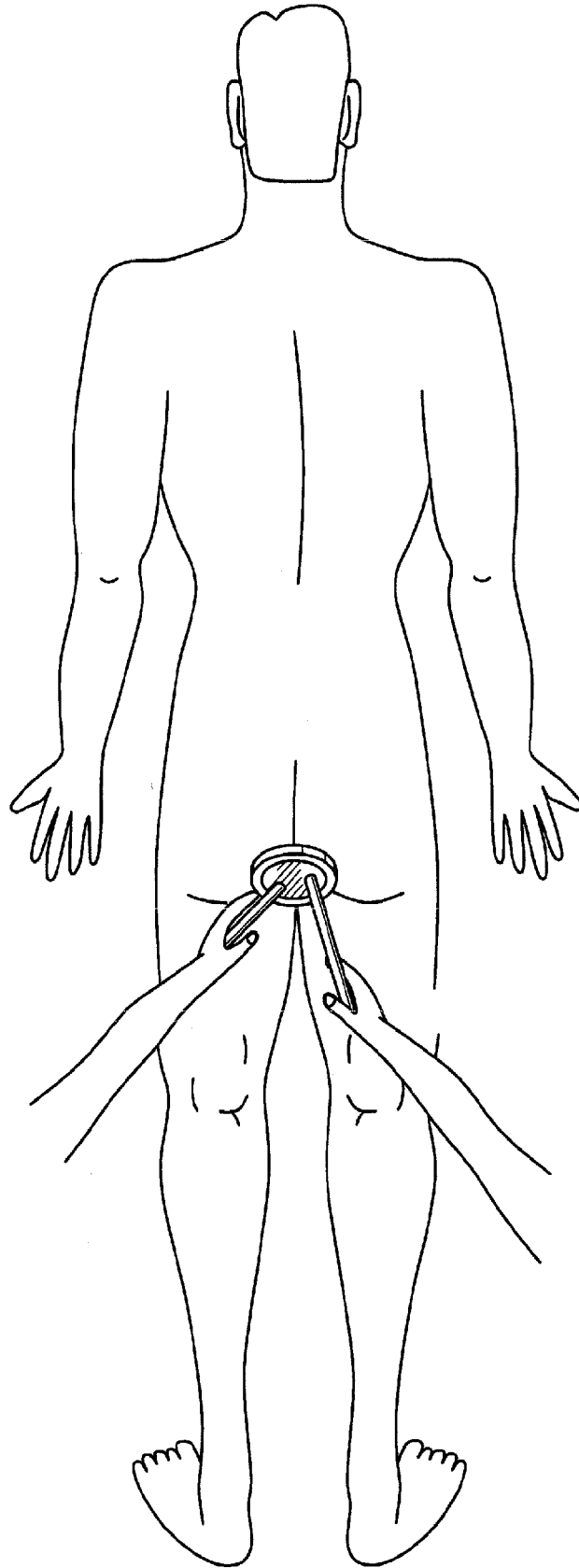
**FIG. 1**



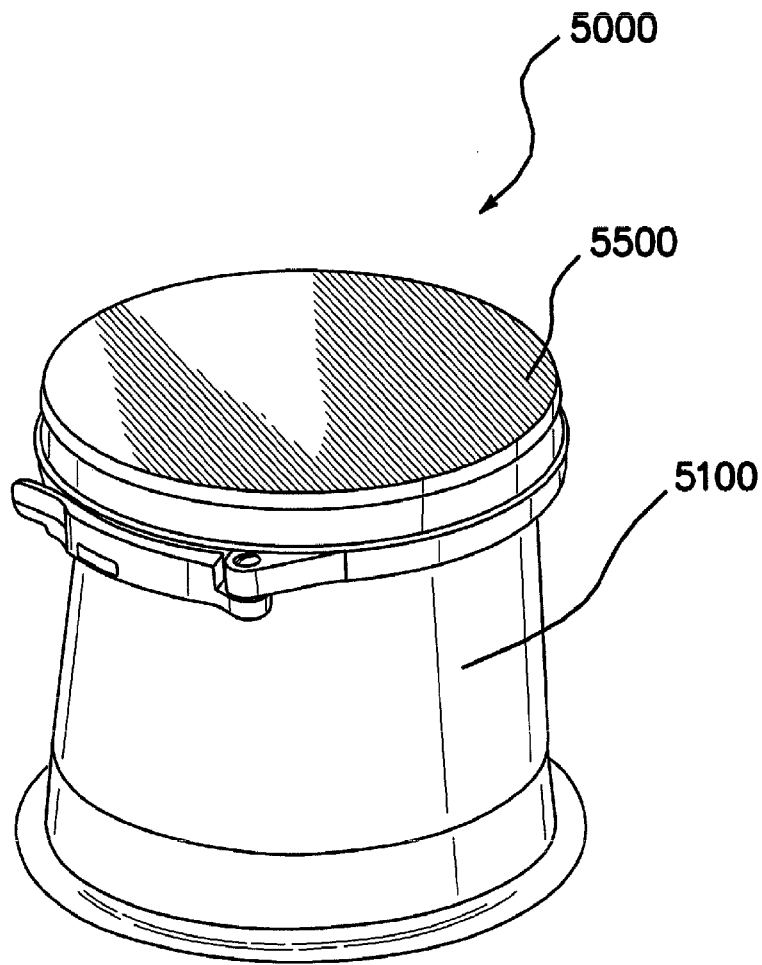
**FIG. 2**



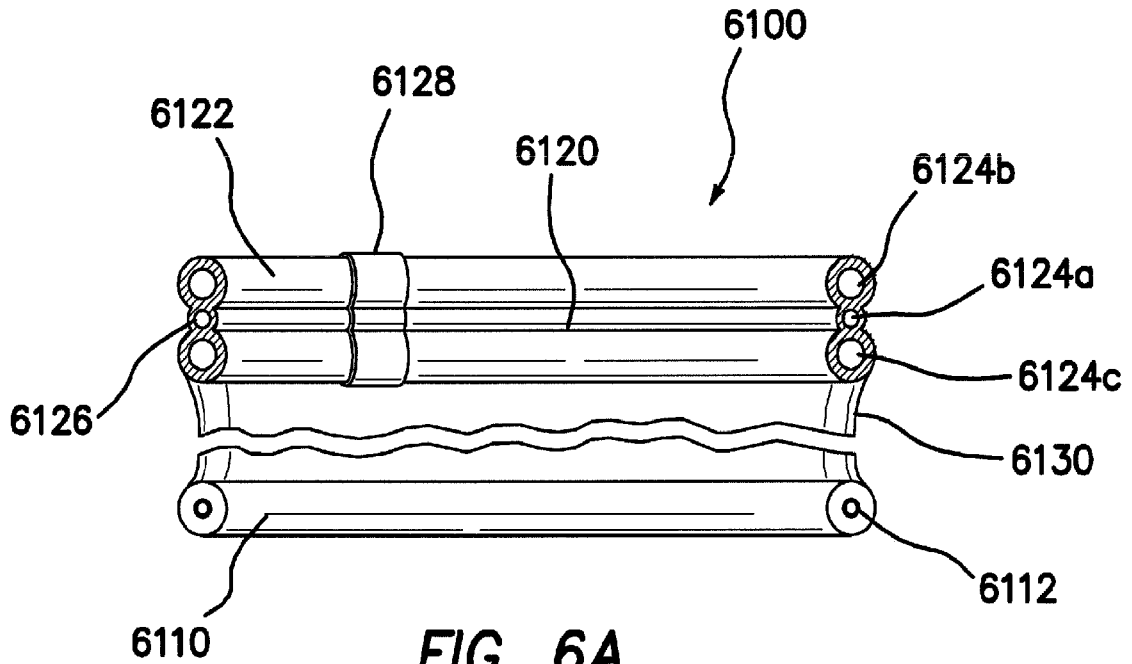
**FIG. 3**



**FIG. 4**



**FIG. 5**



**FIG. 6B**



**FIG. 6C**



**FIG. 6D**

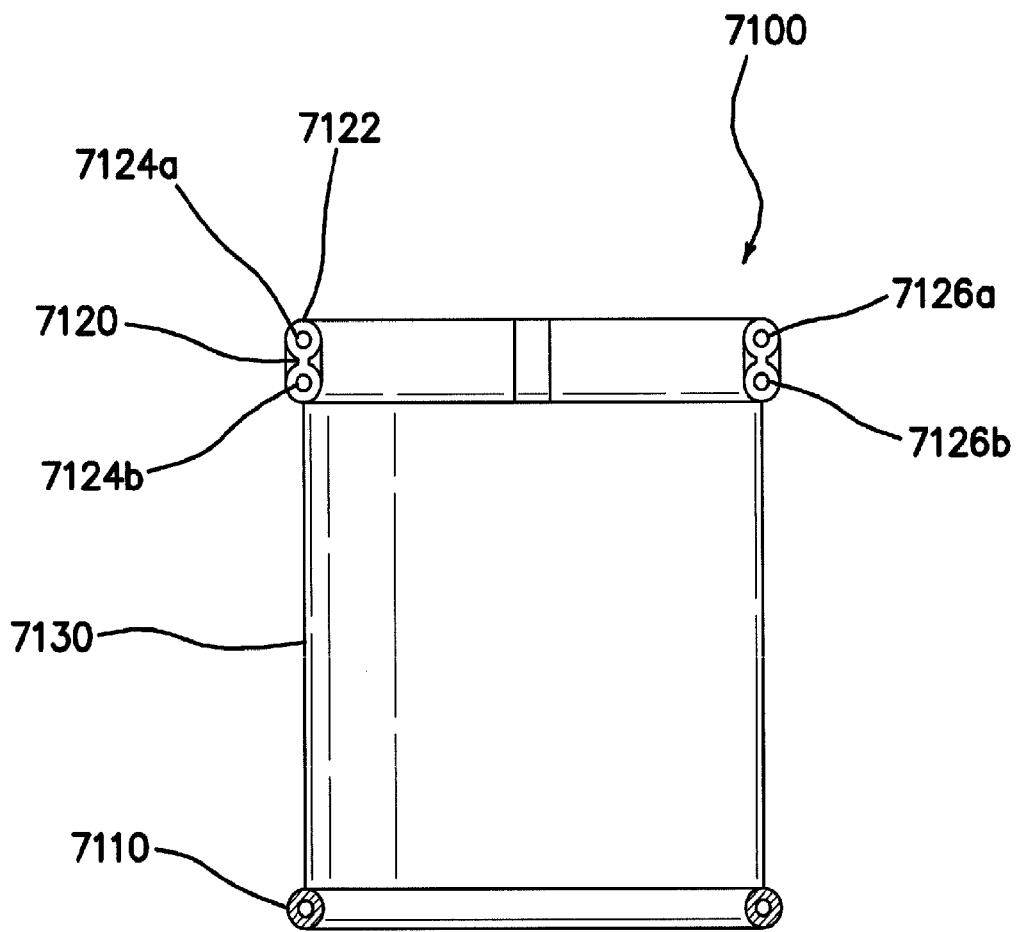
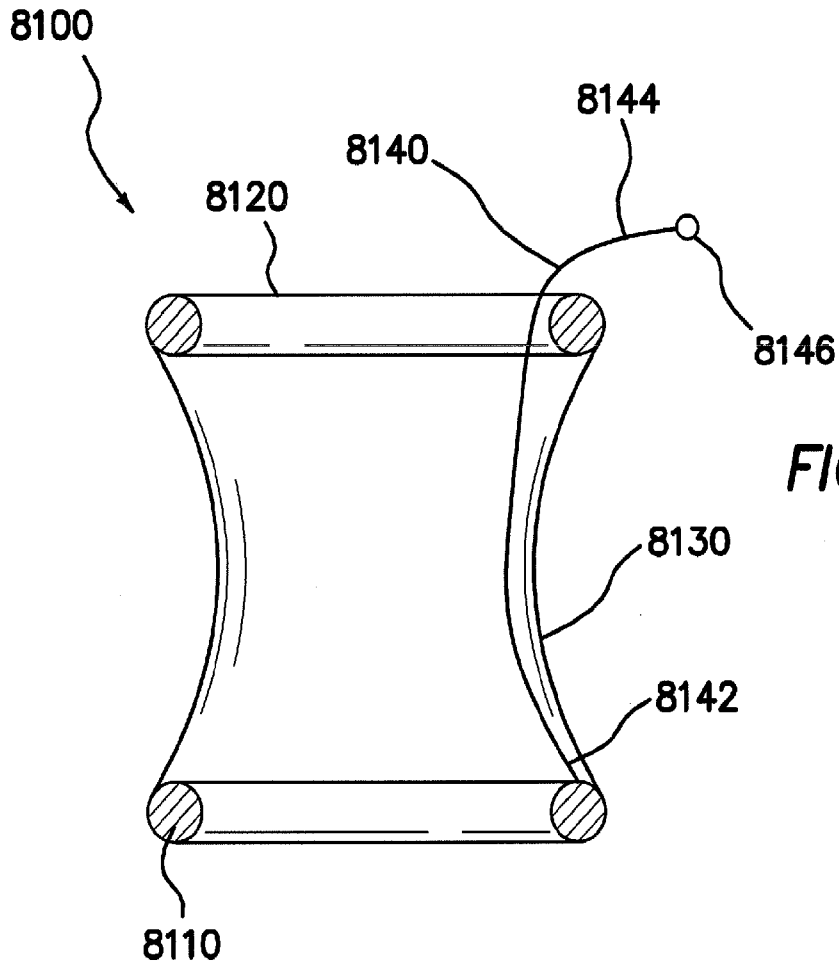
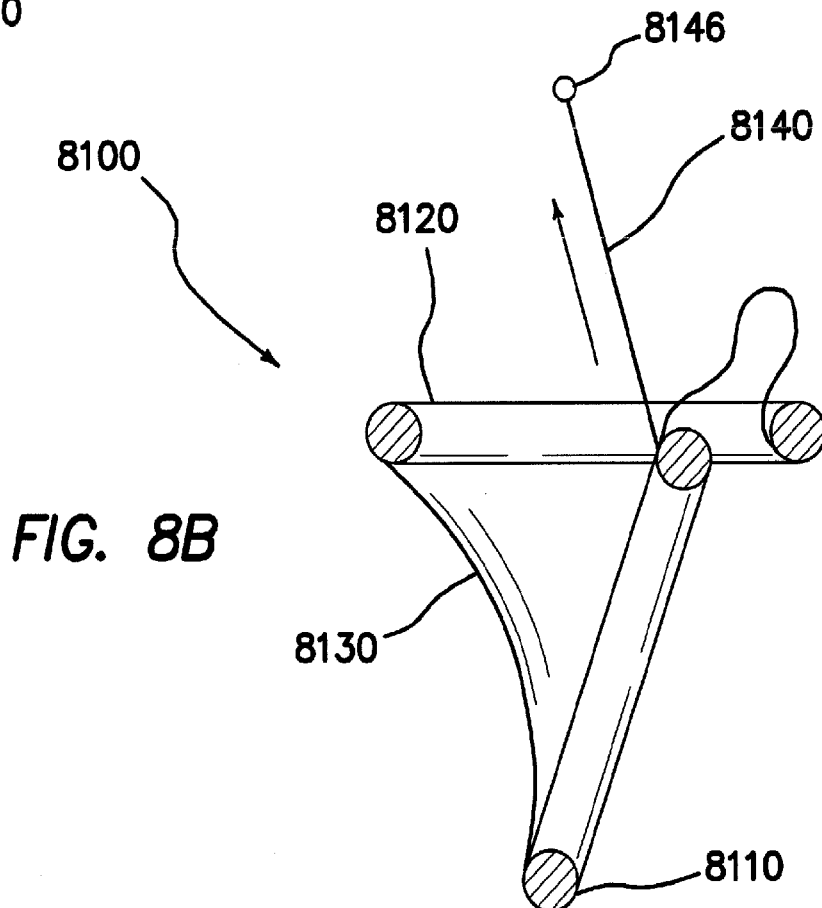


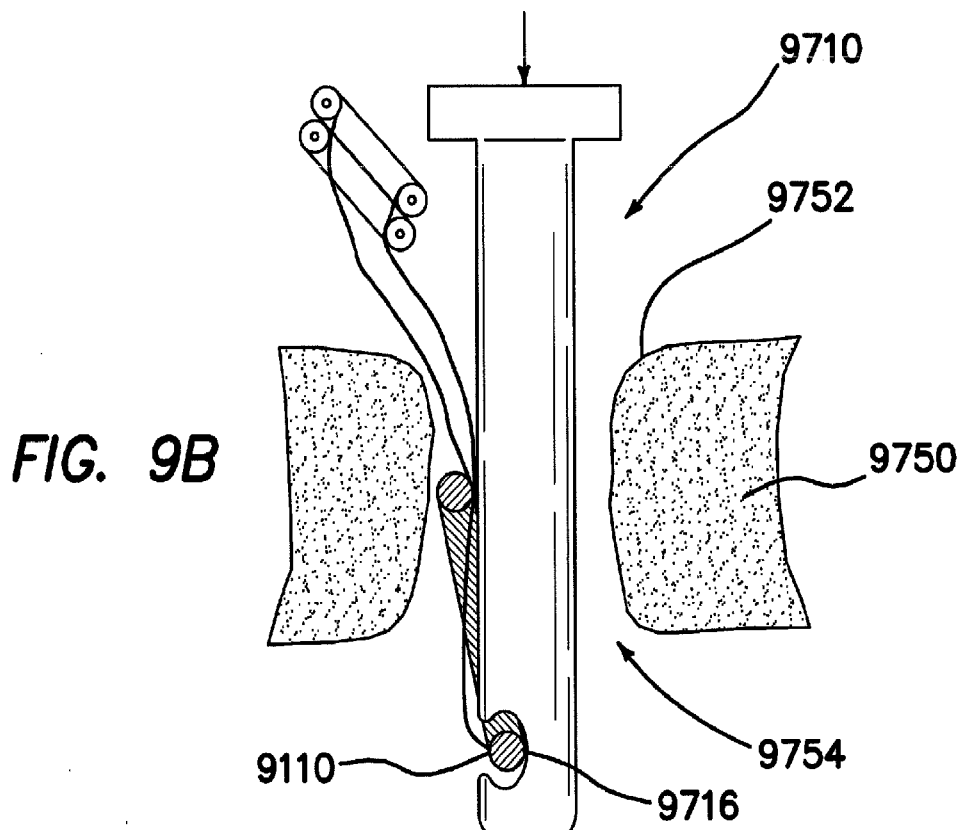
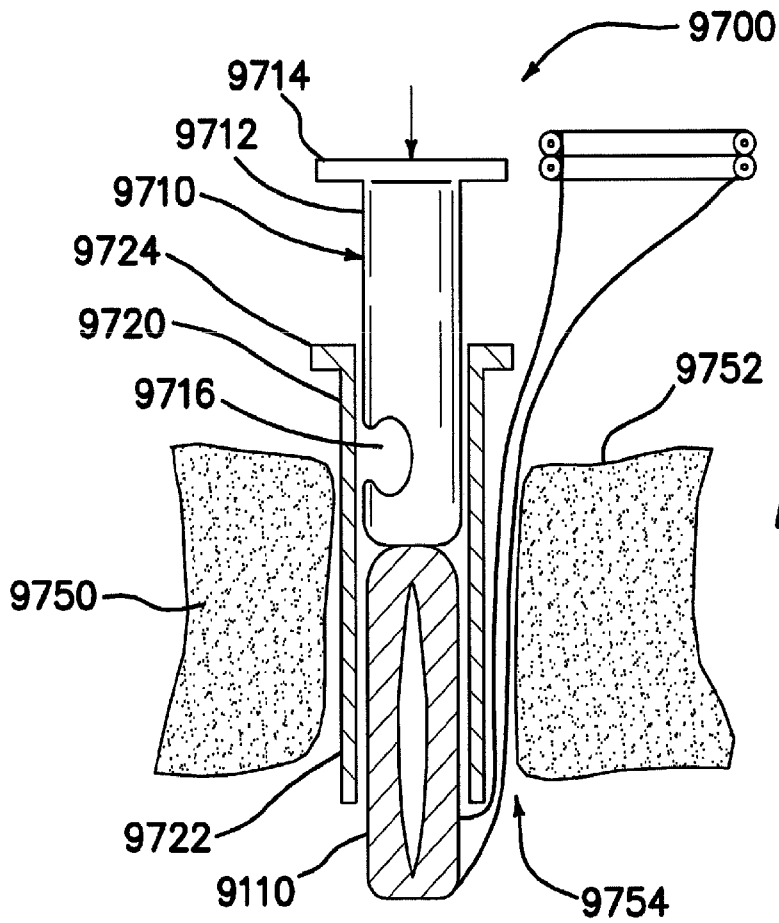
FIG. 7

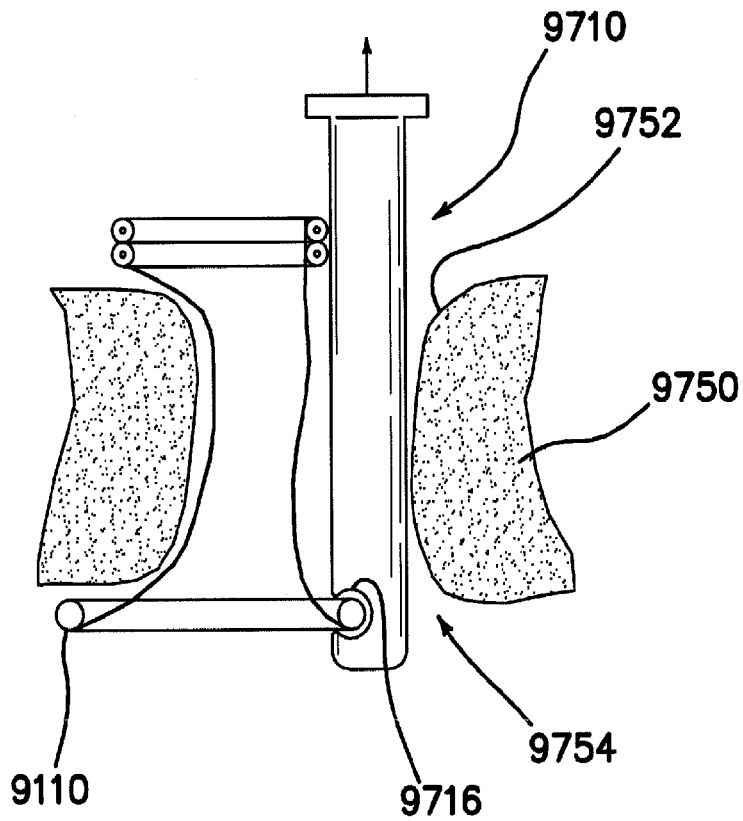


**FIG. 8A**

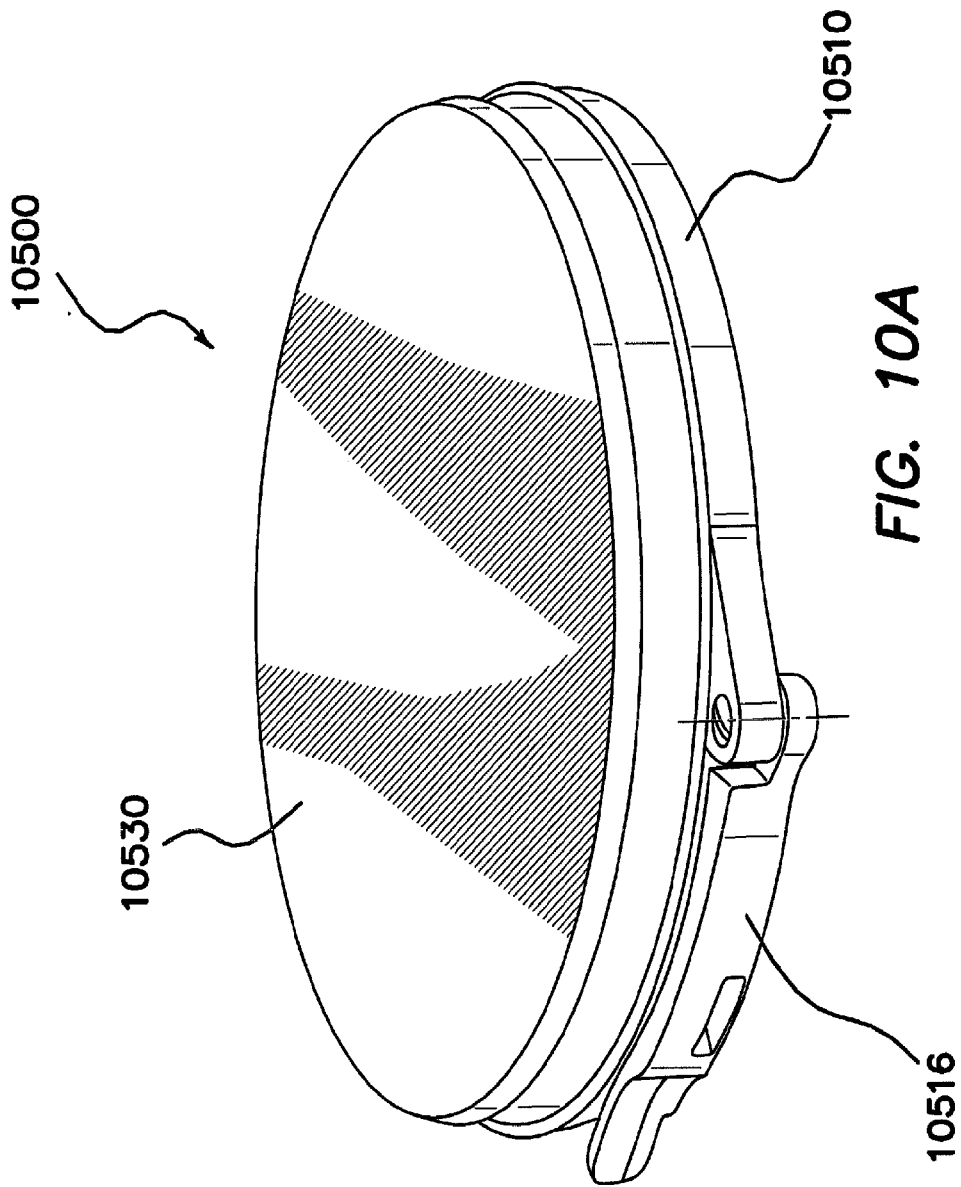


**FIG. 8B**





**FIG. 9C**



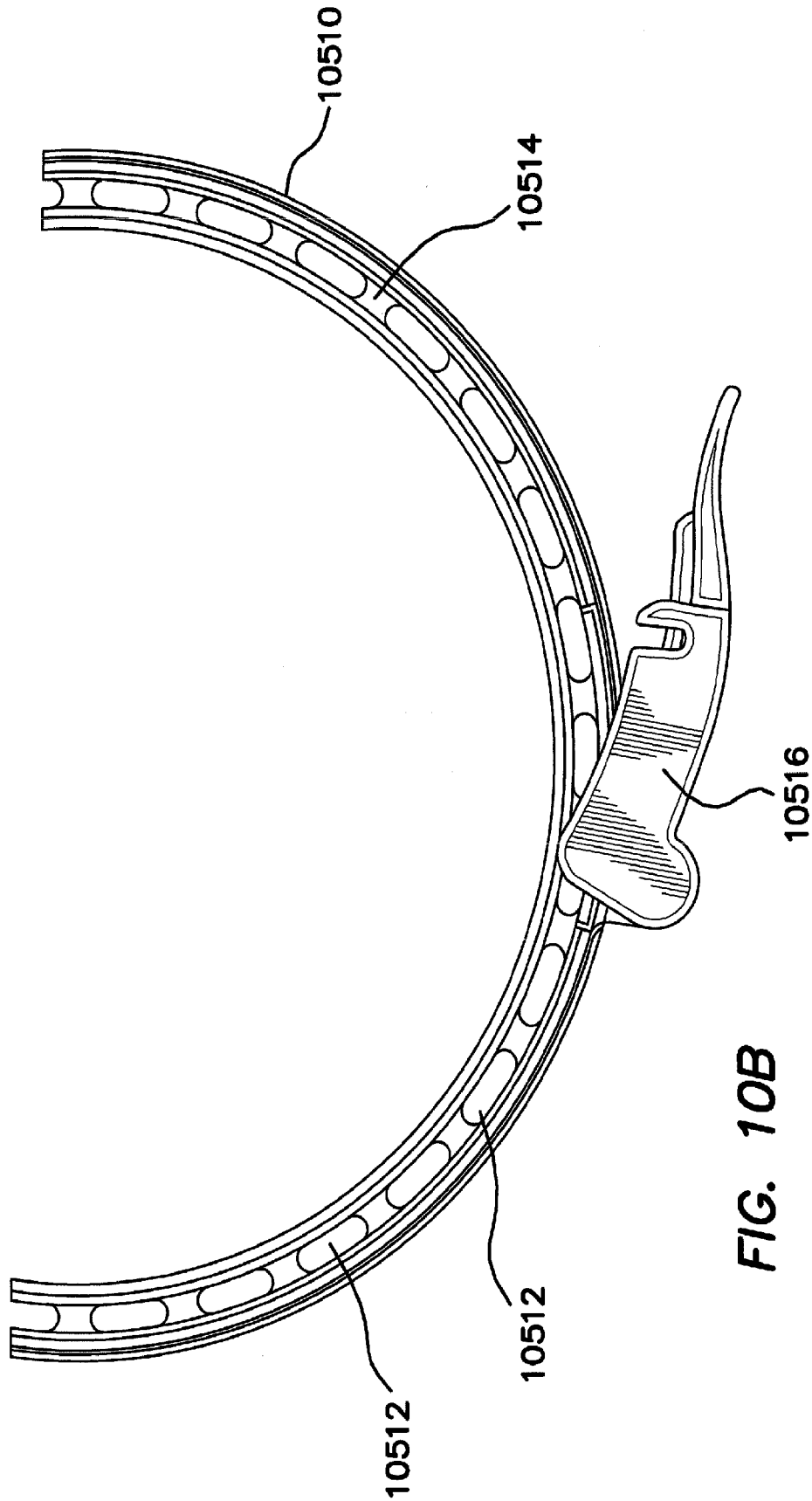


FIG. 10B

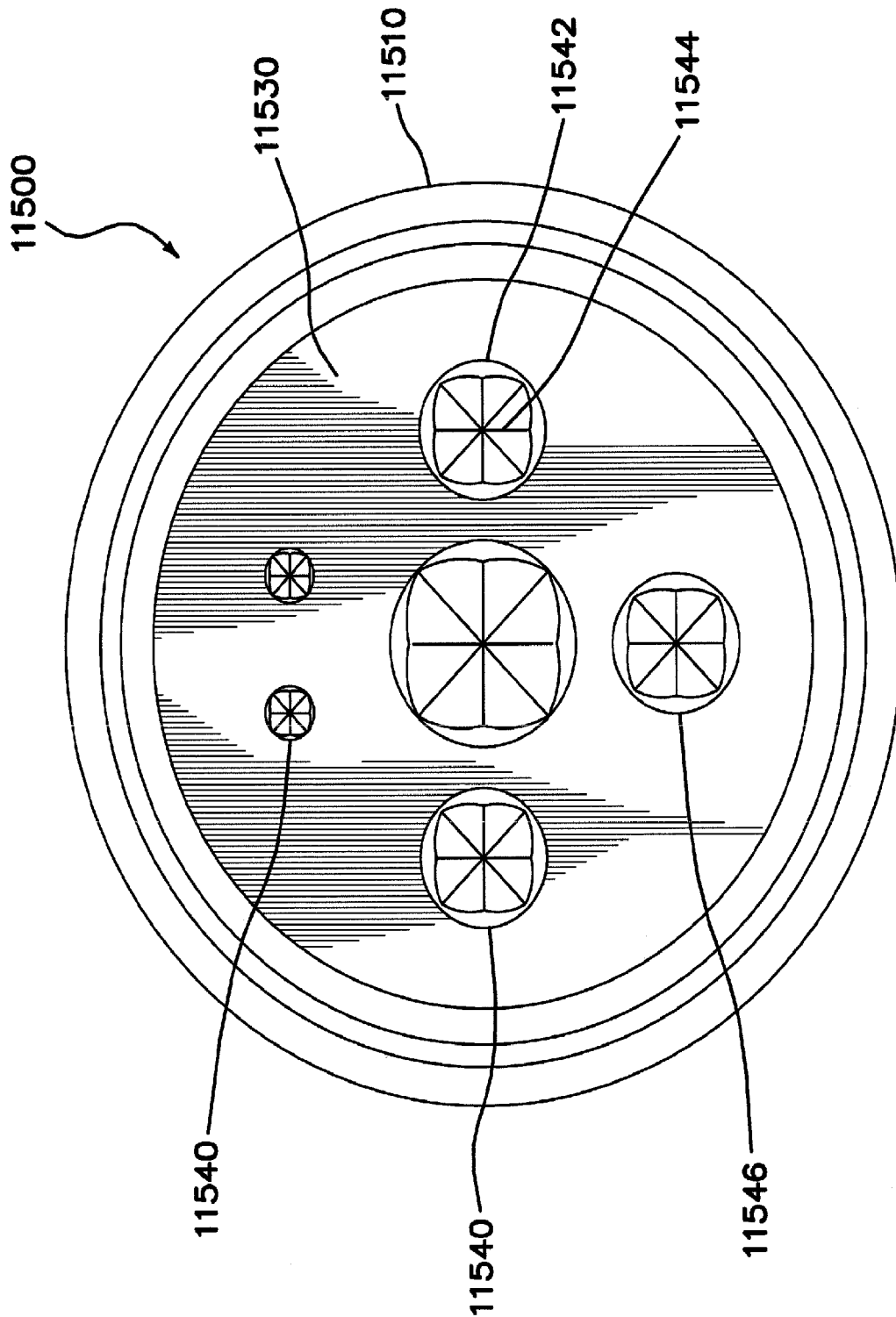


FIG. 11A

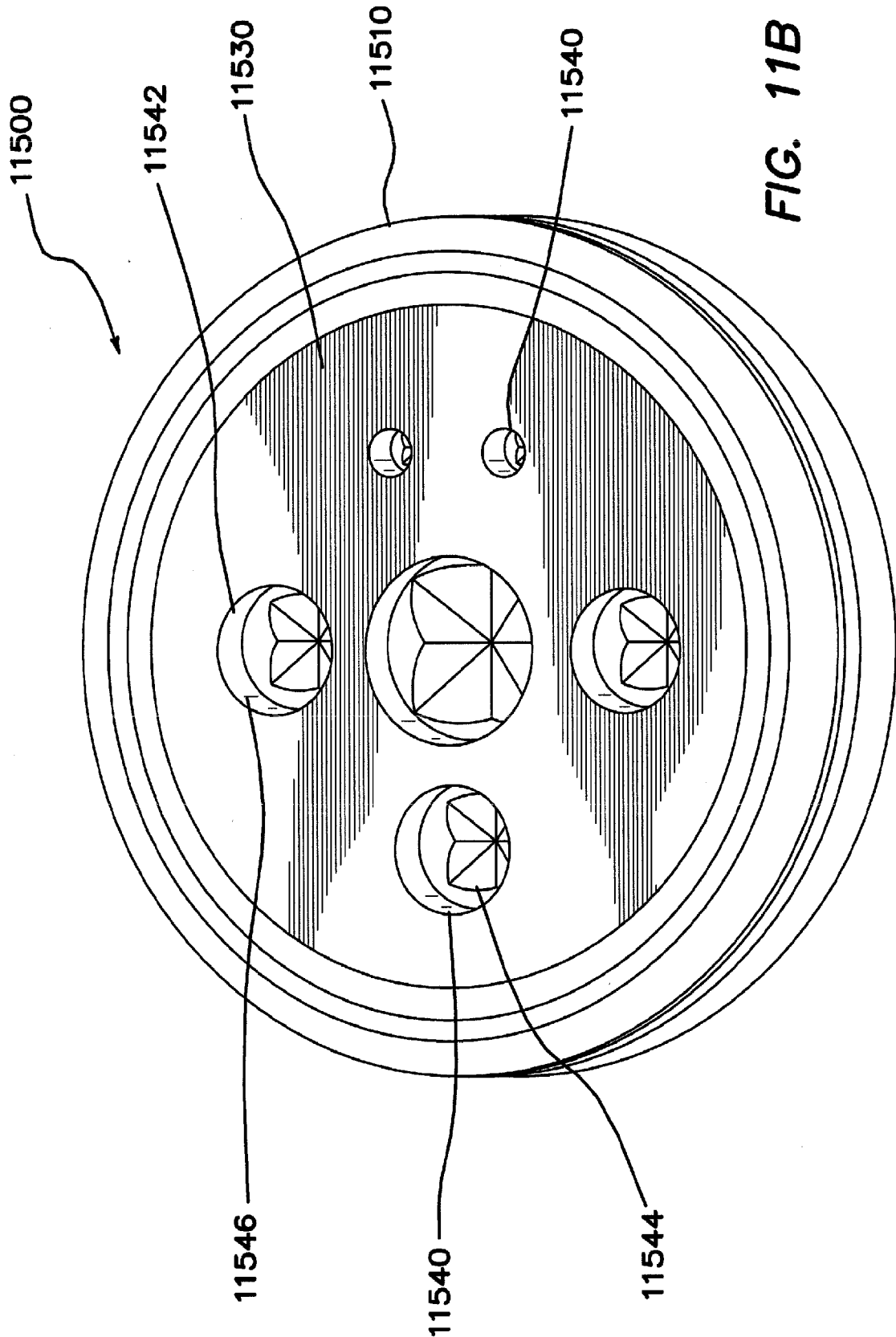


FIG. 11B

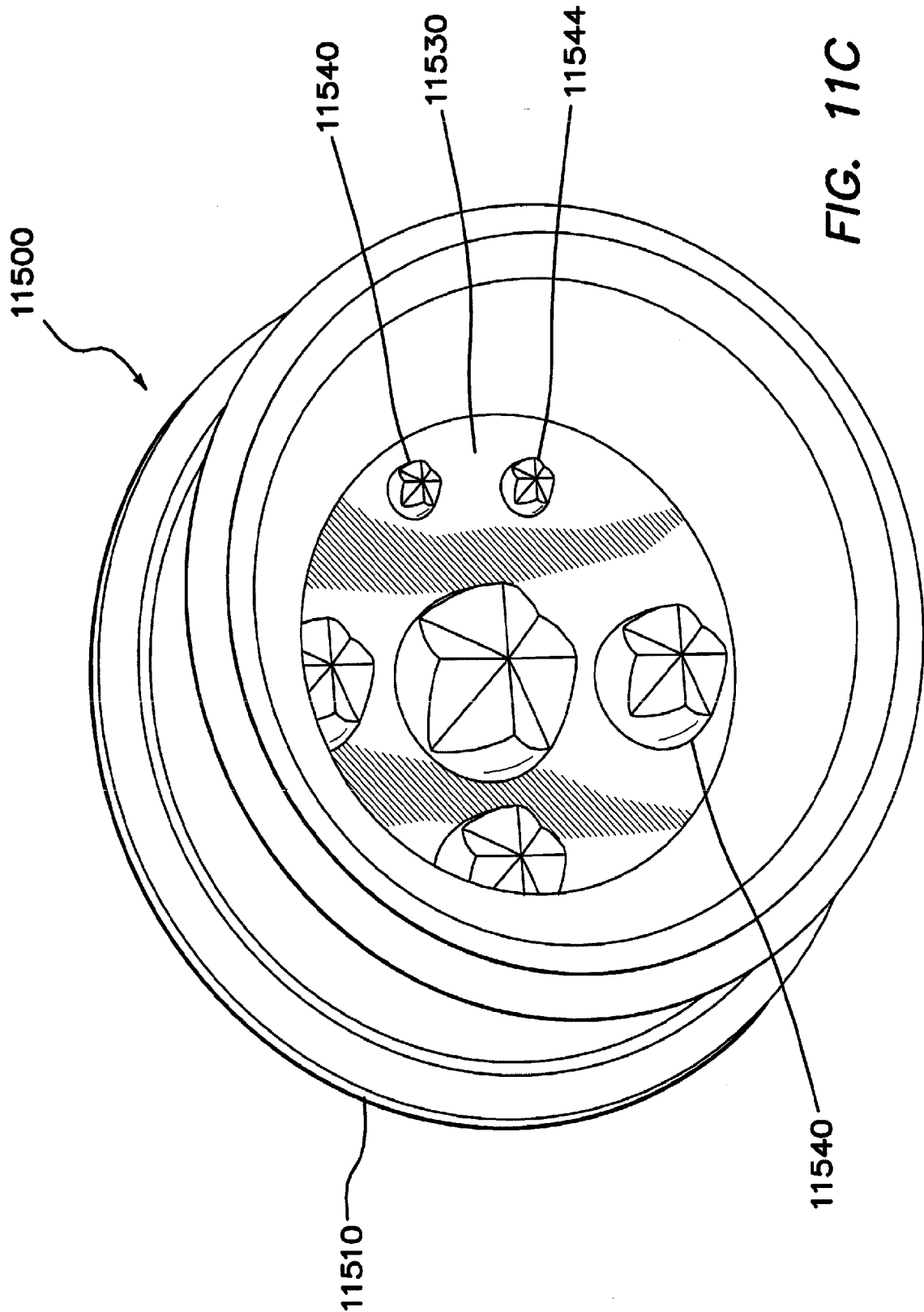


FIG. 11C

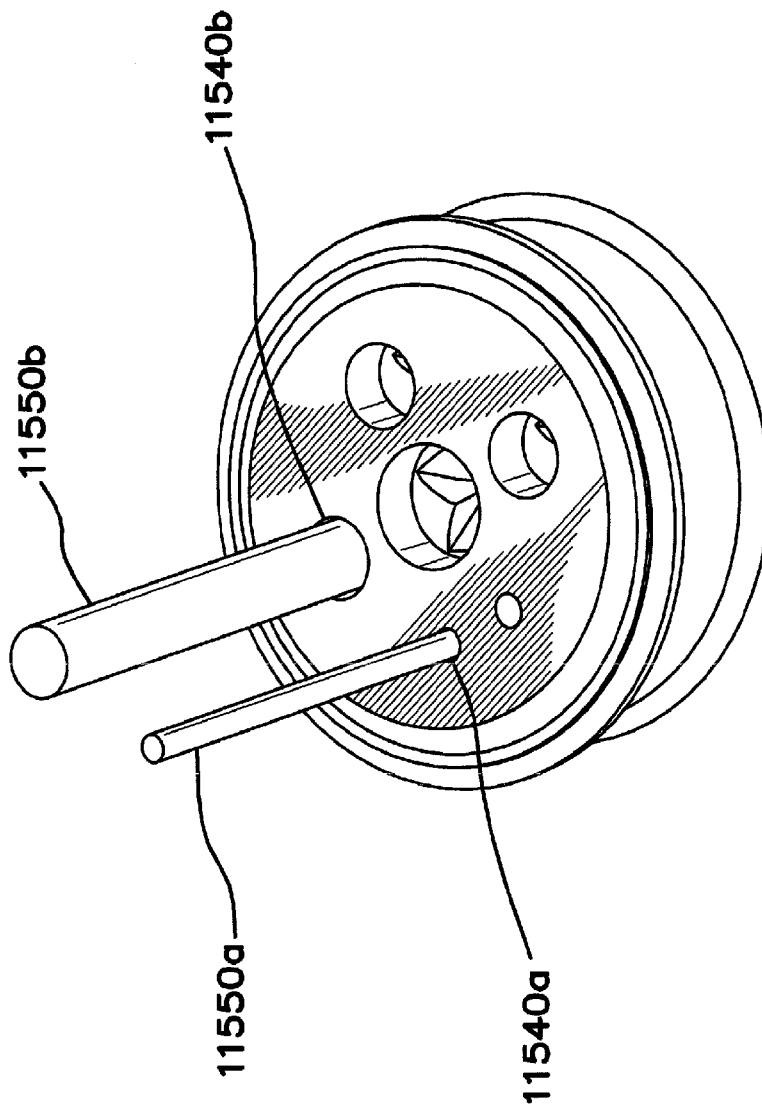


FIG. 11D

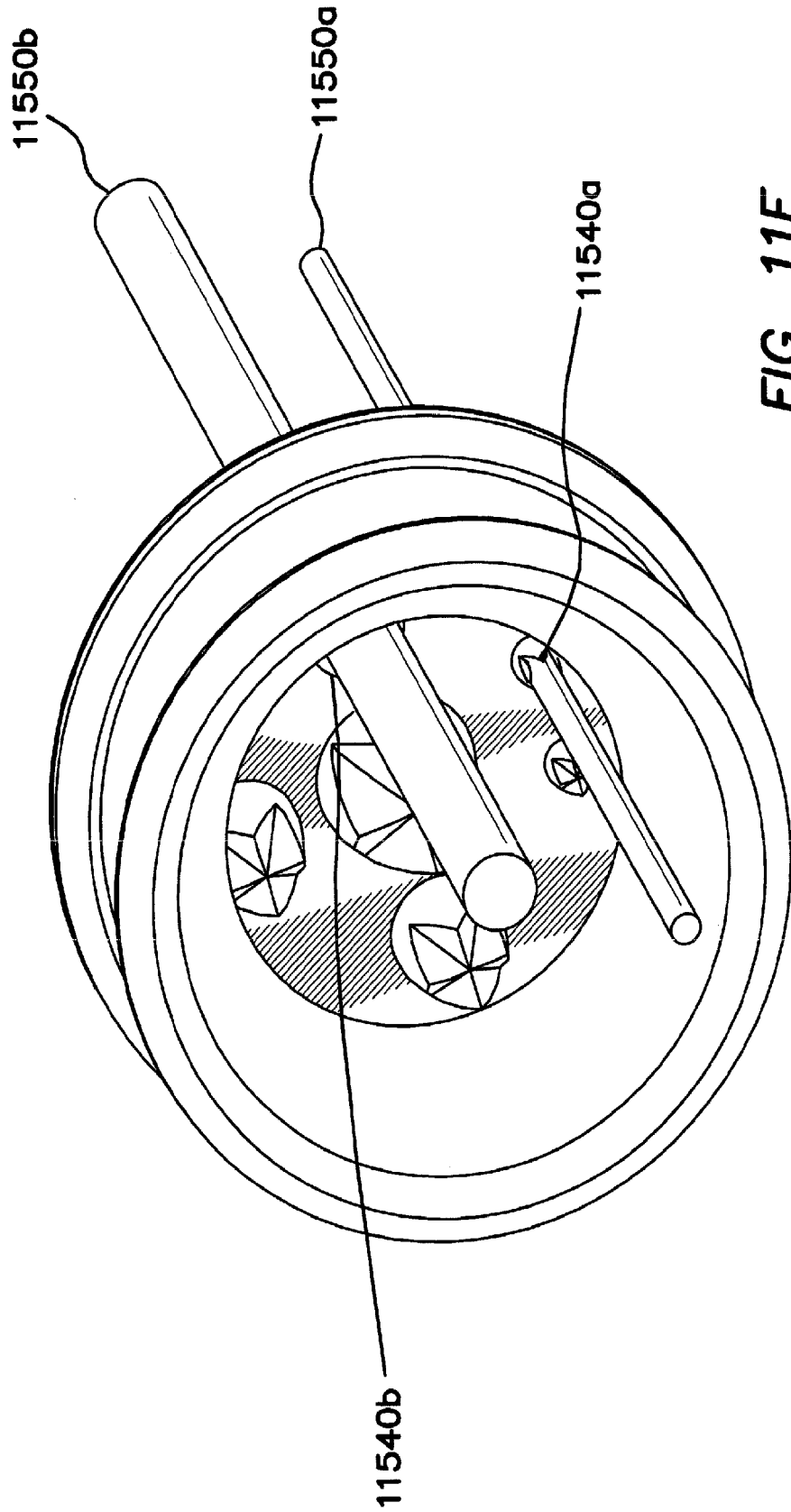
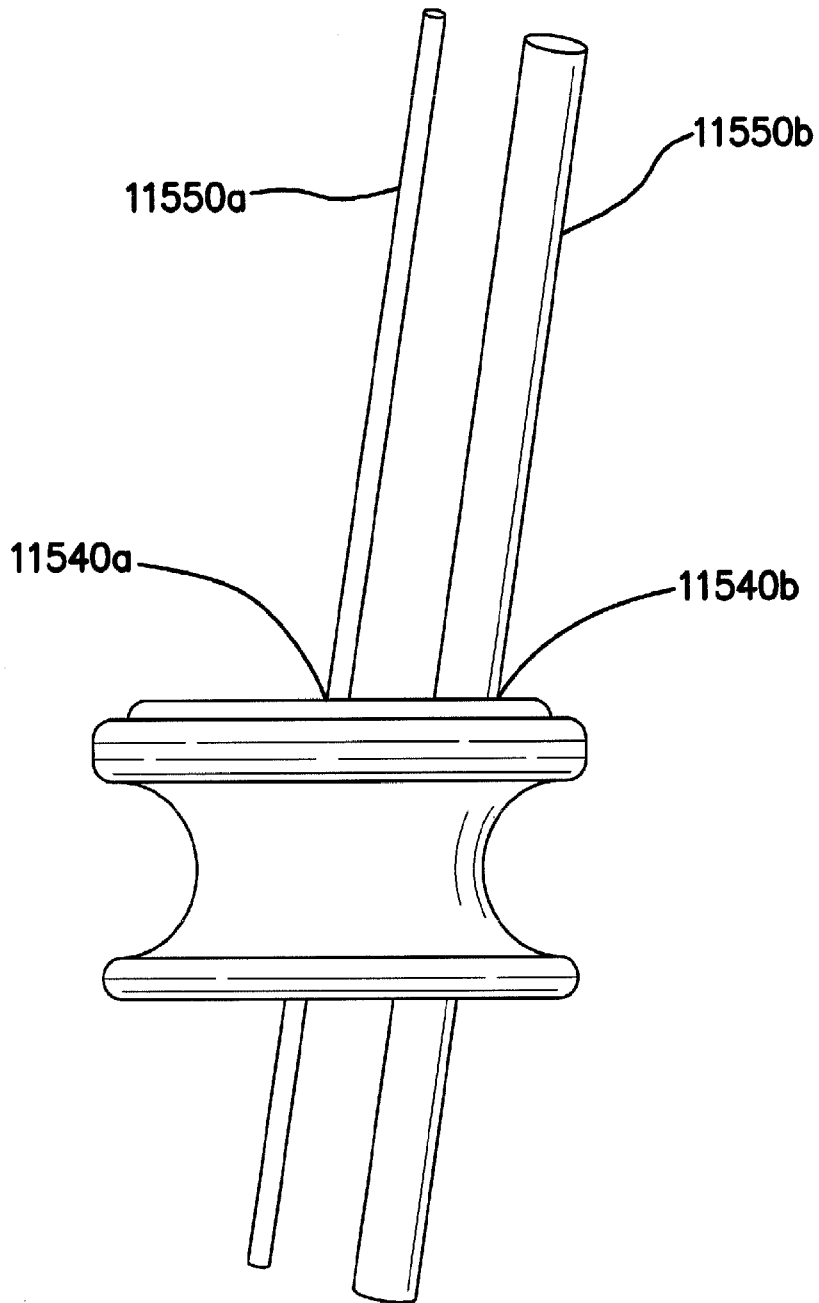


FIG. 11E



**FIG. 11F**

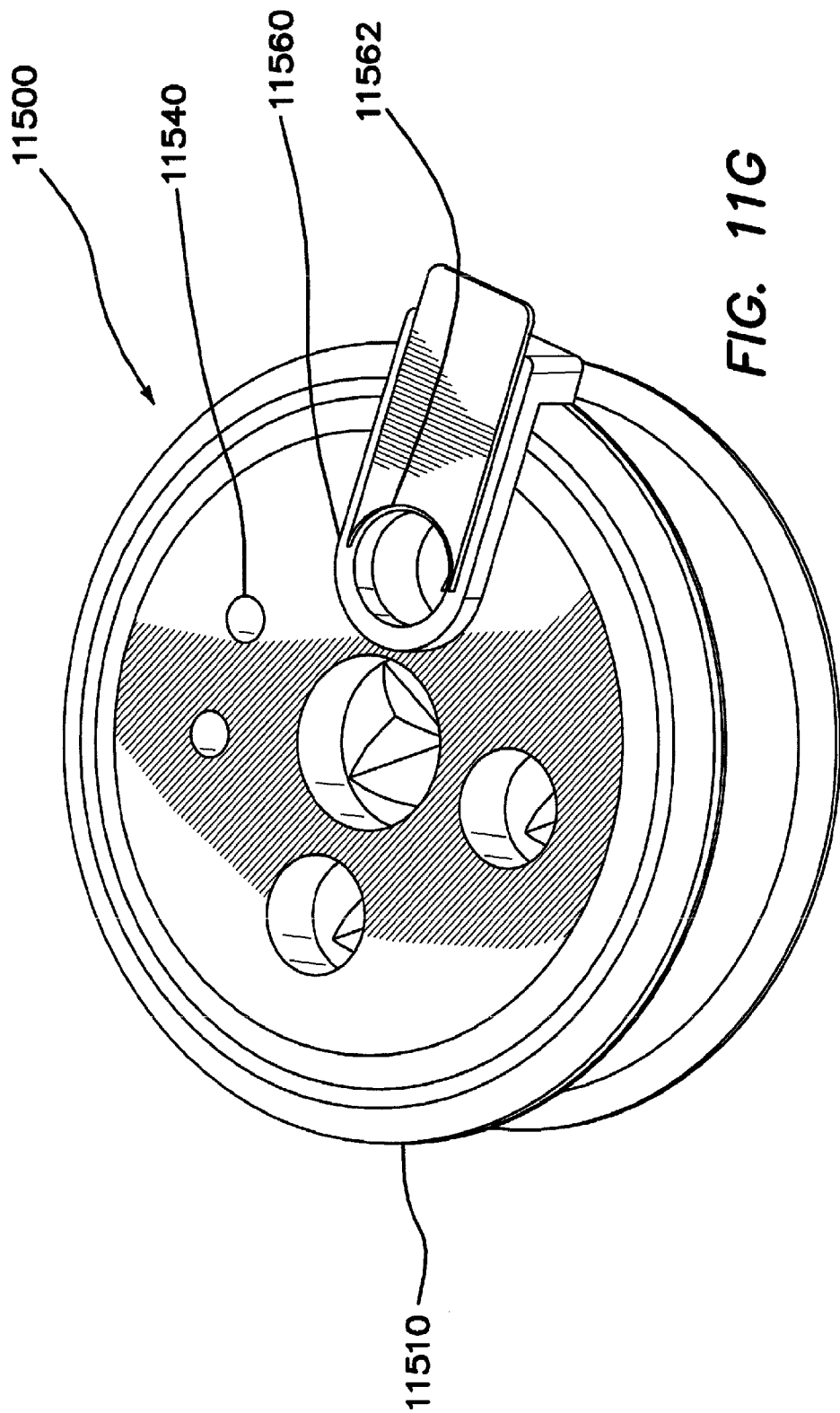


FIG. 11G

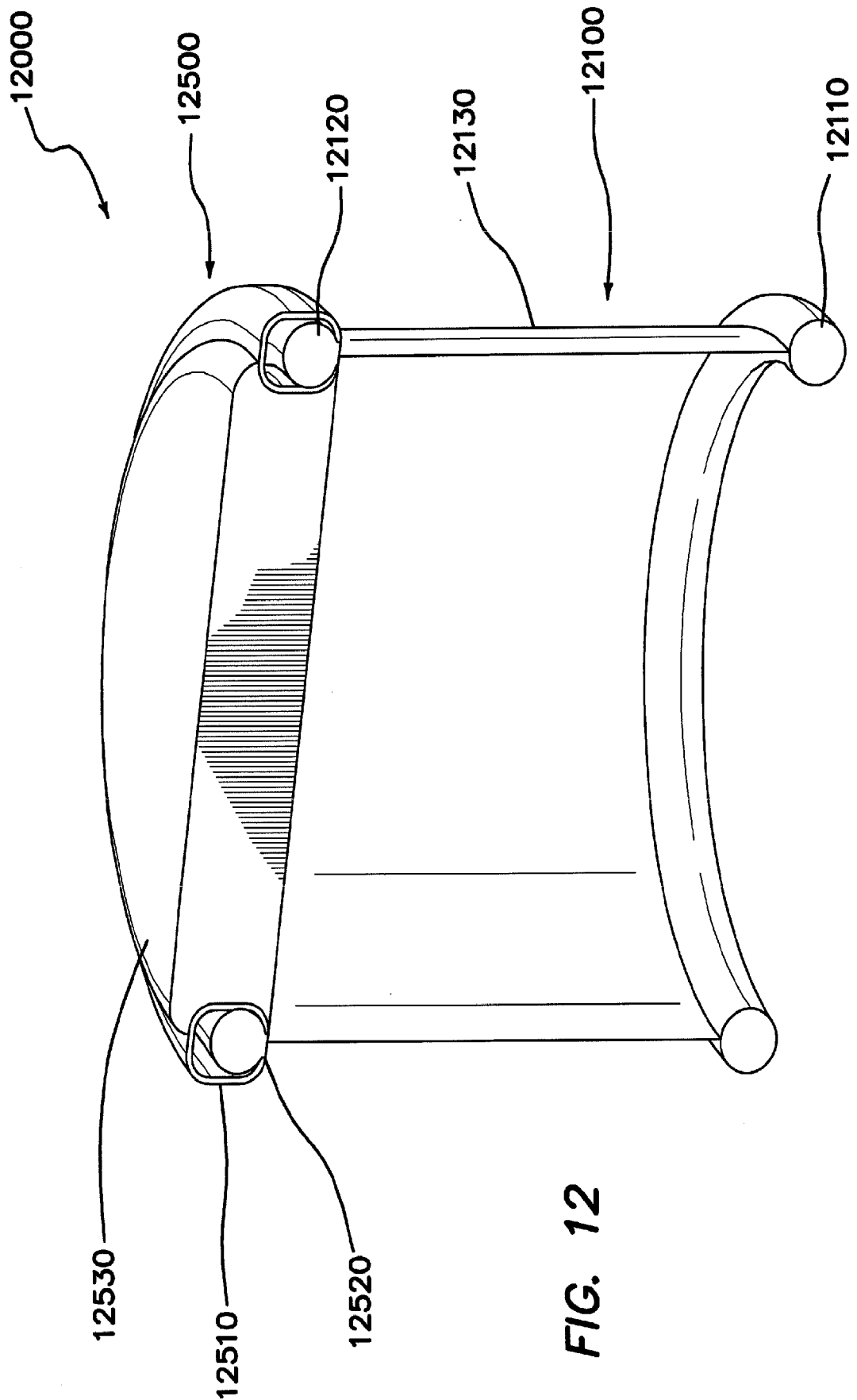
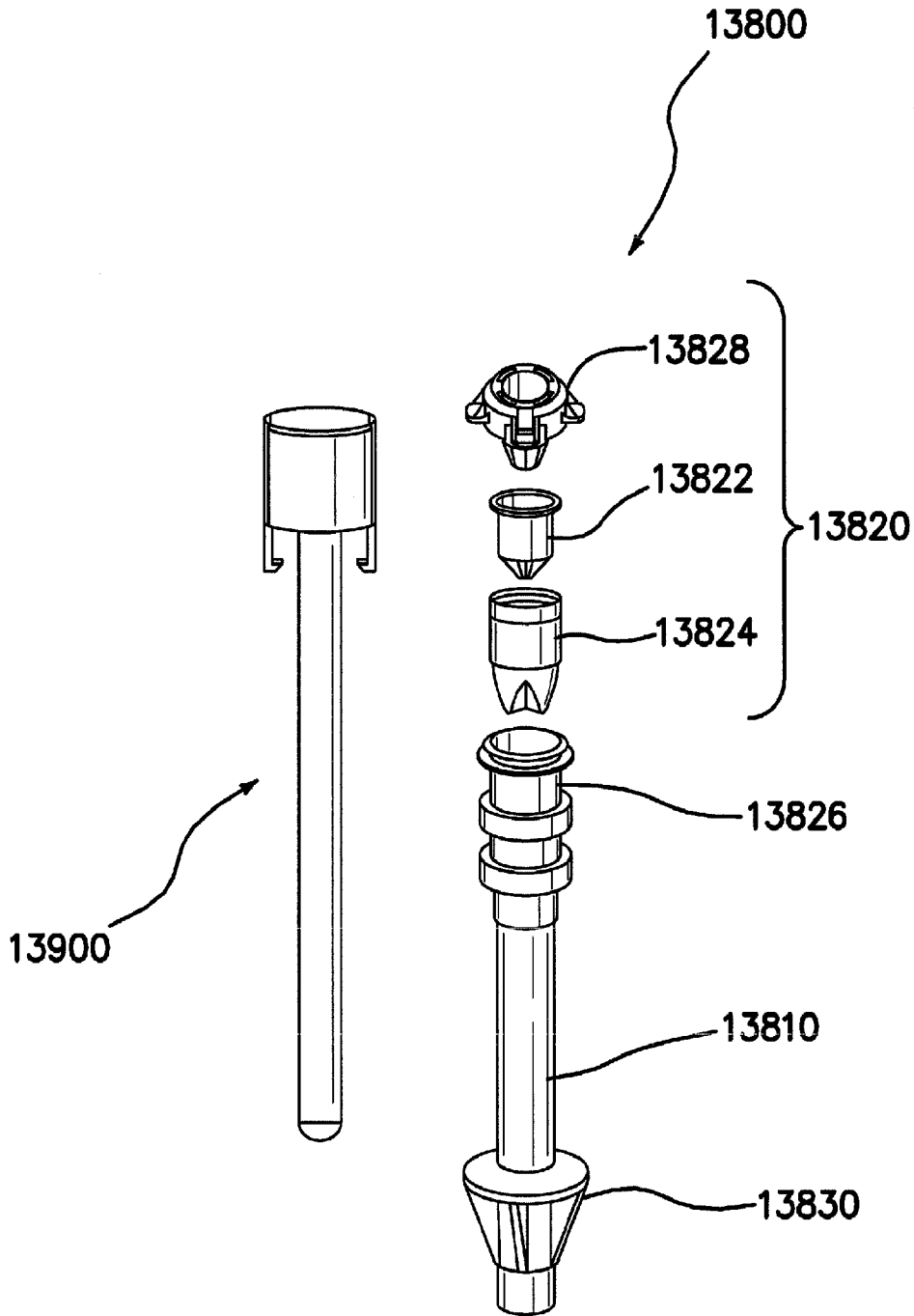


FIG. 12



**FIG. 13**

## INTERNATIONAL SEARCH REPORT

International application No.

PCT/US 09/31724

<b>A. CLASSIFICATION OF SUBJECT MATTER</b> IPC(8) - A61M 5/14 (2009.01) USPC - 604/256 According to International Patent Classification (IPC) or to both national classification and IPC		
<b>B. FIELDS SEARCHED</b> Minimum documentation searched (classification system followed by classification symbols) UPSC: 604/256 Documentation searched other than minimum documentation to the extent that such documents are included in the fields searched UPSC: 604/256, 19, 48, 93.01, 246, 264, 275, 278, 600/201, 206, 207, 208 See Search Terms Below Electronic data base consulted during the international search (name of data base and, where practicable, search terms used) pubWEST(PGPB,USPT,EPAB,JPAB); Google Search Terms Used: valve, opening, access, point, retractor, ring, move\$4, reposition\$3, tether, inner, distal, notch, pivot\$4, applied, medical, resources		
<b>C. DOCUMENTS CONSIDERED TO BE RELEVANT</b>		
Category*	Citation of document, with indication, where appropriate, of the relevant passages	Relevant to claim No.
X	US 2007/0185387 A1 (ALBRECHT et al) 9 August 2007 (09.08.2007) entire document, especially para [0006]-[0007], [0035], [0039], [0042]-[0046]	1-3, 5-6, 10-14, 19-20, 24
Y		4, 7-9, 15-18, 21-23, 25-32
Y	US 2007/0088277 A1 (MCGINLEY et al) 19 April 2007 (19.04.2007) para [0090], [0097], fig 41	4, 9, 23, 30
Y	US 2007/0233006 A1 (BRUSTAD) 04 October 2007 (04.10.2007) para [0031], fig 3	7-8, 21-22, 27-32
Y	US 2006/0149137 A1 (PINGLETON et al) 06 July 2006 (06.07.2006) para [0008]-[0009]	15-18, 25-26, 31-32
<input type="checkbox"/> Further documents are listed in the continuation of Box C. <input type="checkbox"/>		
* Special categories of cited documents: "A" document defining the general state of the art which is not considered to be of particular relevance "E" earlier application or patent but published on or after the international filing date "L" document which may throw doubts on priority claim(s) or which is cited to establish the publication date of another citation or other special reason (as specified) "O" document referring to an oral disclosure, use, exhibition or other means "P" document published prior to the international filing date but later than the priority date claimed "T" later document published after the international filing date or priority date and not in conflict with the application but cited to understand the principle or theory underlying the invention "X" document of particular relevance; the claimed invention cannot be considered novel or cannot be considered to involve an inventive step when the document is taken alone "Y" document of particular relevance; the claimed invention cannot be considered to involve an inventive step when the document is combined with one or more other such documents, such combination being obvious to a person skilled in the art "&" document member of the same patent family		
Date of the actual completion of the international search 23 February 2009 (23.02.2009)		Date of mailing of the international search report <b>03 MAR 2009</b>
Name and mailing address of the ISA/US Mail Stop PCT, Attn: ISA/US, Commissioner for Patents P.O. Box 1450, Alexandria, Virginia 22313-1450 Facsimile No. 571-273-3201		Authorized officer: Lee W. Young PCT Helpdesk: 571-272-4300 PCT OSP: 571-272-7774

专利名称(译)	手术器械进入装置		
公开(公告)号	<a href="#">EP2237815A4</a>	公开(公告)日	2014-04-09
申请号	EP2009704586	申请日	2009-01-22
[标]申请(专利权)人(译)	应用医疗资源		
申请(专利权)人(译)	应用医疗资源CORPORATION		
当前申请(专利权)人(译)	应用医疗资源CORPORATION		
[标]发明人	ALBRECHT JEREMY J LECHUGA JUAN J BECERRA MATTHEW M GADBERRY DONALD L JOHNSON GARY M BRUSTAD JOHN R		
发明人	ALBRECHT, JEREMY, J. LECHUGA, JUAN, J. BECERRA, MATTHEW, M. GADBERRY, DONALD, L. JOHNSON, GARY, M. BRUSTAD, JOHN, R.		
IPC分类号	A61M5/14 A61B17/34 A61B17/02		
CPC分类号	A61B1/32 A61B17/0293 A61B17/3417 A61B17/3423 A61B17/3462 A61B2017/3449 A61B2017/345 A61B2017/3452 A61B2017/3454 A61B2017/3466		
优先权	61/022772 2008-01-22 US 61/104963 2008-10-13 US		
其他公开文献	EP2237815A1		
外部链接	<a href="#">Espacenet</a>		

#### 摘要(译)

用于单个或有限端口过程的进入装置系统的实施例包括牵开器和可拆卸地连接到牵开器的凝胶帽。凝胶帽包括用作人造体壁的凝胶垫，通过该凝胶垫可以直接或通过一个或多个套管针将器械插入体腔。凝胶垫允许灵活的仪器放置，以及仪器的平移和角度自由度，同时保持气密密封。