

Description

TECHNICAL FIELD

[0001] The present invention relates to a PET/MRI hybrid machine that combines a PET device with an MRI device, and more particularly to an open PET/MRI hybrid machine that can simultaneously measure and image the same open space accessible from outside by the PET device and the MRI device, thereby acquiring biological functional information and morphological information at the same time.

BACKGROUND ART

[0002] PET is a method of administering a compound that is labeled with positron-emitting radionuclides and imaging the distribution of the compound in the body as a tomographic image. While X-ray CT or MRI based tomographic images provide morphological information, PET images are referred to as functional images which express biological functional information. For example, PET images are capable of highly sensitive tumor detection though not precise in position. To add accurate positional information to a PET image, it is needed to superpose an X-ray CT image or MRI image, which is precise in position but low in sensitivity and detection power, on the PET image. For efficient superposition and scanning, PET/CT devices have been prevalent that combine a PET device and an X-ray CT device.

[0003] Since X-ray CT is typically higher than PET in exposure level, hybrid machines with MRI, which is free from radiation exposure, have been under development. (See Ciprian Catana et al. "Simultaneous Acquisition of Multislice PET and MR Images: Initial Results with a MR-Compatible PET Scanner" *The Journal of Nuclear Medicine*, Vol. 47, No. 12, December 2006 pp 1968-1976.)

[0004] Using such a PET/MRI hybrid machine, functional information and morphological information can be integrated to obtain highly-sensitive and accurate positional information. MRI techniques for imaging some biological functions, typified by fMRI, have also been advancing, and such PET/MRI hybrid machines can even acquire a PET-based functional image and an MRI-based functional image simultaneously. In any case, however, the closed field of view imposes a lot of psychological stress on the subject as well as makes interventional treatment difficult.

[0005] Meanwhile, open MRI devices have been developed and released that acquire MRI images of an open space. (See Joshua Lilienstien et al. "In Vivo Sonography Through an Open MRI Breast Coil to Correlate Sonographic and MRI Findings" *AJR*: 184, March 2005 s49-52, Hiroshi Iseki et al. "Intelligent Operating Theater Using Intraoperative Open-MRI" *Magnetic Resonance in Medical Sciences*, Vol.4, No.3, p. 129-136, 2005, Junta Harada et al. "Initial Experience of Percutaneous Renal Cryosurgery under the Guidance of a Horizontal Open

MRI System" *Radiation Medicine*, Vol. 19, No. 6, 291-296 p.p., 2001, DiMaio SP et al. "Robot-assisted needle placement in open MRI: system architecture, integration and validation" *Comput Aided Surg.* 2007 Jan; 12(1): 15-24, DiMaio SP et al. "Robot-assisted needle placement in open MRI: system architecture, integration and validation" *Stud Health Technol Inform.* 2006; 119: 126-31.)

[0006] Such open MRI devices are used to administer treatments under MRI guidance, making use of MRI's high spatial resolution and noninvasiveness. Conventionally, the only modality capable of imaging an open space in a tomographic device has been MRI, whereas the applicant has proposed an open PET device that allows PET diagnosis even during treatment. (Taiga Yamaya, Taku Inaniwa, Shinichi Minohara, Eiji Yoshida, Naoko Inadama, Fumihiko Nishikido, Kengo Shibuya, Chih Fung Lam and Hideo Murayama, "A proposal of an open PET geometry," *Phy. Med. Biol.*, 53, pp. 757-773, 2008.) According to the technology, two separate detector rings are arranged apart in the direction of the body axis, and radiations are detected from lines of coincidence between the rings. This allows imaging of the open space between the detection rings.

[0007] The PET device, however, has had a problem that the PET device by itself is not capable of acquiring morphological information.

DISCLOSURE OF THE INVENTION

[0008] The present invention has been achieved in order to solve the foregoing conventional problems, and it is an object thereof to make it possible to simultaneously measure and image the same open space accessible from outside by PET and MRI, thereby acquiring functional information and morphological information at the same time.

[0009] The foregoing object of the present invention has been achieved by the provision of a PET/MRI hybrid machine that combines a PET device with an MRI device, including: an open PET device that has a PET field of view at least part of which is an open space accessible from outside; and an open MRI device that has an MRI field of view at least part of which is an open space accessible from outside, the open space of the PET field of view and the open space of the MRI field of view being allowed to overlap each other at least in part.

[0010] Here, two composite rings may be opposed to each other with an open space accessible from outside therebetween so that the PET field of view and the MRI field of view are allowed to overlap each other in the open space, the two composite rings each including one of detector rings of the open PET device arranged in one of magnets (i.e., coils creating static magnetic field) of the open MRI device.

[0011] An MRI RF coil may be fixed to or movably arranged on a bed that is insertable into the composite rings, and the RF coil and/or the bed may be moved so

that the RF coil enters the open space to allow the PET field of view and the MRI

field of view to overlap each other.

[0012] The RF coil may be moved with respect to the bed and in a longitudinal direction of the bed so as to adjust the MRI field of view in position.

[0013] A working unit may be arranged in the open space.

[0014] The working unit may be retractably arranged in the open space.

[0015] The working unit may be any of an image acquisition unit, an irradiation device, and a general-purpose interventional treatment unit, or a combination thereof.

[0016] The general-purpose interventional treatment unit may include at least any one of an automatic puncture device, an electromagnetic cautery needle, and a laparoscope.

[0017] The same field of view may be simultaneously imaged in three or more modalities.

[0018] A PET and/or MRI image(s) may be acquired at least once both before and after operation of the working unit.

[0019] A marking of a target position identified by a PET image that is acquired before operation of the working unit may be put on a simultaneously-acquired MRI image, and the marking may be displayed on a PET and/or MRI image(s) acquired after the operation of the working unit.

[0020] According to the present invention, it becomes possible to simultaneously measure and image the same open space accessible from outside by the PET device and the MRI device, thereby acquiring functional information and morphological information at the same time. This can provide a highly useful open space.

[0021] For example, treatment and PET/MRI diagnosis can be combined to check the position by MRI, diagnose biological functions by PET, and administer a real-time interventional treatment at the same time. Aside from conventional radiation therapy, treatment methods that can be combined include an ultrasonic cautery needle, puncture, a puncture cautery needle, ultrasonic-based sonodynamic therapy (SDT), laser-based photodynamic therapy (PDT), thermotherapy, radiation triggering, and RF triggering.

[0022] Performing diagnosis on the head in a PET/MRI device with a long tunnel-like patient port imposes high psychological stress on the subject. According to the present invention, the simultaneous PET and MRI measurements of the open space can significantly reduce the stress on the subject.

[0023] Open-type devices provide doctors and operators easy access to the subject, allowing easy condition check. In particular, in the field of brain researches, responses to visual and other stimulations are sometimes inspected by PET or MRI. The presence of the open

space facilitates experiments.

[0024] Moreover, the open space allows installation of a third diagnostic device and the like, whereby the same field of view can be simultaneously imaged in three or more modalities. Examples of the third diagnostic device include an ultrasonic device, a SPECT device, a fluorescent imager, an optical camera, and an optical CT device.

BRIEF DESCRIPTION OF THE DRAWINGS

[0025]

Fig. 1 is a block diagram showing the overall configuration of a first embodiment of the present invention, including a side view and a front view thereof;

Fig. 2 is a perspective view showing the configuration of essential parts of the first embodiment and modifications thereof;

Fig. 3 is a block diagram showing the overall configuration of a second embodiment of the present invention, including a side view and a front view thereof;

Fig. 4 includes a side view and a front view showing the configuration of essential parts of a third embodiment of the present invention;

Fig. 5 is a block diagram showing the configuration of essential parts of a fourth embodiment of the present invention, including a side view and a front view thereof;

Fig. 6 includes a side view and a front view showing the configuration of essential parts of a fifth embodiment of the present invention;

Fig. 7 is a block diagram showing the overall configuration of a sixth embodiment of the present invention, including a side view and a front view thereof;

Fig. 8 is a block diagram showing the configuration of a general-purpose interventional treatment unit according to the sixth embodiment;

Fig. 9 is a flowchart showing an example of a diagnosis/treatment procedure according to the present invention;

Fig. 10 is a flowchart showing another example of the diagnosis/treatment procedure according to the present invention; and

Fig. 11 is a flowchart showing a modification of the diagnosis/treatment procedure according to the present invention.

BEST MODE FOR CARRYING OUT THE INVENTION

[0026] Hereinafter, embodiments of the present invention will be described in detail with reference to the drawings.

[0027] As shown in Fig. 1, a first embodiment of the present invention includes an open MRI device 20 of so-called doubled doughnut type, having two magnets 22 and 24 which are arranged apart in the direction of the body axis of a subject 8. Antimagnetic PET detector rings

32 and 34 are arranged in patient ports on respective sides to constitute composite rings 42 and 44. The space between the two separated, opposed composite rings 42 and 44 is the overlapping open space of MRI and PET. In the diagram, 12 represents a pedestal of a bed 10, 26 represents an MRI imaging device, 36 represents a coincidence circuit for PET measurement, 38 represents a PET imaging device, and 40 represents a composite image display which displays a morphological image obtained by the MRI imaging device 26 and a functional image obtained by the PET imaging device 38 in a superposed manner.

[0028] With such a configuration, radiations are measured from lines of coincidence between the PET detector rings 32 and 34, whereby the same open space as that of the MRI device can be imaged by PET. Working units such as an image acquisition unit, an irradiation device, and a general-purpose interventional treatment unit may be arranged in the open space. Coincidence measurement by the PET detector ring 32 itself and coincidence measurement by the PET detector ring 34 itself can be combined to acquire PET images over a wide field of view in the direction of the body axis, including the open space.

[0029] In Fig. 1, the composite rings 42 and 44 including the PET detector rings 32 and 34 arranged in the magnets 22 and 24, respectively, are arranged apart in the direction of the body axis of the subject 8 as shown in Fig. 2(A). However, the system configuration is not limited thereto. As shown in Fig. 2(B), the opposed composite rings 42 and 44 may be arranged apart in a direction orthogonal to the body axis of the subject. As shown in Fig. 2(C), the circular PET detector rings 32 and 34 may be arranged apart in the direction of the body axis of the subject 8 in the open space of a hamburger-shaped open MRI device 50. Alternatively, as shown in Fig. 2(D), elliptical PET detector rings 52 and 54 may be arranged apart in the direction of the body axis of the subject 8 in the open space of the hamburger-shaped open MRI device 50.

[0030] According to the example of Fig. 2(A), the head of the subject is easily accessible. According to the example of Fig. 2(D), the distance between the magnets 22 and 24 of the MRI device 50 can be reduced for device miniaturization.

[0031] Next, a second embodiment of the present invention will be described in detail with reference to Fig. 3.

[0032] In the present embodiment, an RF coil 60 for MRI is fixed to or movably arranged on the bed 10. The RF coil 60 and/or the bed 10 is/are moved in the direction of the body axis of the subject 8 so that the RF coil 60 enters the open space to make the PET field of view and the MRI field of view overlap each other. The RF coil typically has a circular cylindrical frame structure to surround the affected area. The RF coil usually has a lot of openings and will not interfere with access to the affected area.

[0033] According to the present embodiment, the RF

coil 60 and/or the bed 10 can be moved in the body axis of the subject 8 to adjust the field of view of the MRI image in position.

[0034] Fig. 4 shows an example where an inspection tube 64 of a laparoscope device 62 is inserted into the open space as a working unit and laparoscopic inspection/treatment is administered to the subject 8 according to the foregoing first embodiment.

[0035] Laparoscopic or endoscopic inspections and treatments refer to inspections and associated treatments using a laparoscope or angioscope, where a small cut is made in the skin or the like to insert the inspection tube 64, and inspections and associated treatments using an endoscope, where the inspection tube 64 is inserted through an aperture such as nasal and oral cavities. Aside from inspections and treatments that are manually performed by the inspector, inspections and associated treatments that are automatically or semiautomatically performed by mechanical means may also be included.

[0036] Fig. 5 shows an example where a needle 68 of an automatic puncture device 66 as a working unit is inserted into the subject 8 through the open space, similarly using the first embodiment.

[0037] Puncture inspections and treatments refer to inspections and associated treatments that involve inserting an inspection tube or treatment tool having the shape of a needle 68 through the skin or the like. Puncture inspections and treatments include biopsy, tumor cauterization, local administration of anti-tumor agents, and radio-wave therapy. Aside from inspections and treatments that are manually performed by the inspector, inspections and associated treatments that are automatically or semiautomatically performed by mechanical means may also be included.

[0038] In the example of Fig. 5, the automatic puncture device 66 is fixed to a position where the open spaces of both MRI and PET coincide with each other. The automatic puncture device 66 includes a not-shown digital video camera, lighting, a driver of the needle 68, a liquid medicine injection device, an electromagnetic heating device, and a tissue removal device (biopsy).

[0039] MRI images obtained by the MRI device 20, PET images obtained by the PET device (32 and 34), and pictures from the camera installed in the automatic puncture device 66 are transmitted to an image processing device 70, and the driver is controlled to insert the needle automatically and accurately into the intended area in the living body. Here, the three-dimensional position for the needle tip to reach is grasped and precisely controlled by using anatomical image information, angiographic image information, temperature image information, and water molecule diffusion image information from MRI, tumor position image information and malignancy image information from PET, skin surface insert position information and body tilt information from the digital video camera, etc.

[0040] Treatments with liquid medicines, electromag-

netic radiation, and the like are administered from the tip of the needle 68 inserted in the subject 8 if needed. Or, necessary tissue may be removed. The treatment result or the treatment based on the removed tissue is imaged and processed by MRI and PET again, and further treatment is repeated if necessary.

[0041] It should be appreciated that the automatic puncture device 66 may be an automatic biopsy device, an automatic surgery device, and the like. Here, treatments by surgery refer to various surgical inspections and surgical treatments that involve cutting the skin or the like. Aside from inspections and treatments that are manually performed by the operator, inspections and associated treatments that are automatically or semiautomatically performed by mechanical means may also be included.

[0042] Such treatments are possible because both the PET and MRI are open.

[0043] Fig. 6 shows an example where an image acquisition unit and an irradiation device 72 as working units are inserted into the open space to acquire various images or perform irradiation, using the foregoing first embodiment.

[0044] A plurality of conformation radiotherapy techniques involving radiation treatment on a selected tumor (such as heavy particle beam radiation therapy, proton beam radiation therapy, and IMRT) have been developed and receiving attention recently. Such techniques can intensively irradiate the affected area while suppressing damage to normal areas, whereas the irradiation field needs to be set accurately.

[0045] The open PET/MRI according to the present invention enables accurate checking of tumor margins by MRI when making a final treatment plan immediately before irradiation. Grasping low oxygen regions and active regions in the tumor by PET allows fine adjustments to the dose balance in the irradiated area. Conventionally, a treatment plan has been made by using CT or the like on a different day, in which case detailed information is not available and there is a risk of misalignment.

[0046] With the open PET/MRI, whether the actual irradiation field is set according to the treatment plan can be checked even during irradiation based on certain MRI measurements, PET ligands, and PET auto-radioactivation measurements. This allows quick irradiation assessment. Conventionally, it has been possible to predict radiation damage that appears a few months later.

[0047] Moreover, conformation radiotherapy often needs an irradiation angle as wide as 360°. The design of the open PET/MRI is right suited to such uses.

[0048] An image acquisition unit may be used to acquire images of the surface of the living body or inside the living body. The image acquisition unit may include visible light cameras and videos, optical measurements using visible light, infrared or near infrared cameras, X-ray CT, simple X-ray images, X-ray video cameras, fluorescent or luminescence imaging, optical coherence tomography, ultrasonic image probes, laser scanners, and

MRI radio frequency coils.

[0049] Radiation or heat treatments refer to inspections and associated treatments that involve applying electromagnetic waves, sonic waves, ultrasonic waves, vibrations, heat, or the like from the surface of the skin or from a remote area. Inspections and treatments that involve irradiation with infrared rays, near infrared rays, visible light, X-rays, gamma rays, various types of particle beams, sonic waves, ultrasonic waves, vibrations, heat, and the like may be included. Medication and inspections to be triggered by such irradiations may also be included.

[0050] Fig. 7 shows an example where a general-purpose interventional treatment unit 80 as a working unit is arranged in the open space according to the first embodiment. The general-purpose interventional treatment unit 80 is connected with an automatic puncture control device 82 as well as a cautery needle control device 84, an endoscope control device 86, and the like. In the example, the image processing device 70 generates control data for the general-purpose interventional treatment unit 80 and performs feedback control on the inspection tube 64, the needle 68, etc.

[0051] Fig. 8 is a block diagram showing the control of Fig. 7 in detail. The general-purpose interventional treatment unit 80 includes: a connection unit 80A which serves as an interface with the automatic puncture control device 82, the cautery needle control device 84, the endoscope control device 86, and the like; a control unit 80B which performs drive control, electromagnetic wave irradiation control, optical A/D conversion, image recognition control, and the like; and connection and drive units such as a puncture drive unit 80C, an electromagnetic wave irradiation unit 80D, and an optical fiber unit 80E.

[0052] Fig. 9 is a flowchart showing the procedure in an example where positioning is performed by using MRI images (steps 100, 102, and 104). After treatment (step 106), PET and/or MRI diagnosis (step 108, 110, and 112) is performed and an instant evaluation is made on the treatment result (step 114).

[0053] Fig. 10 is a flowchart showing one example of the procedure for situations where a cancer position is identified by FDG-PET before treatment, followed by cancer treatment. PET needs a time frame longer than that of MRI. In the example, a target position is identified by using a PET image (step 200), and its marking is put (step 204) on an MRI image that is simultaneously acquired (step 202). Under the MRI guidance, the interventional treatment device is positioned to the target (steps 206 and 208). After treatment (step 106), PET and/or MRI image diagnosis (steps 108, 110, and 112) is performed and an instant evaluation is made on the treatment result (step 114).

[0054] Fig. 11 is a flowchart where a step of displaying the marking put in step 204 on a PET and/or MRI image (step 111) is added to between the step of making PET and/or MRI image diagnosis (step 108 and 110) and the morphological and functional diagnosis step (step 112) of Fig. 10. This makes it possible to accurately check

changes in the same area that is imaged at different times.

[0055] In any of Figs. 9 to 11, the PET scan and imaging processing (step 108, 200) and the MRI scan and imaging processing (step 110, 202) may be performed in reverse order. In Fig. 9, the MRI scan and imaging processing 110 may be omitted to make a diagnosis based only on the PET image in step 108. In Fig. 10, either one of the PET scan and imaging processing 108 and the MRI scan and imaging processing 110 may be omitted.

[0056] If in step 114 the treatment is determined not to be completed yet, then in step 116, determination is made as to whether treatment needs to be replanned. If not, the processing returns to step 106 to repeat the treatment according to the same treatment plan. If treatment needs to be replanned, a treatment plan is made again.

[0057] While the foregoing description has dealt with the cases where the number of PET detector rings is two, the number of PET detector rings may be three or more.

[0058] A television, computer, or other display for visualization, audio equipment, an odor generation device or tube, a skin irritating device, a taste stimulating device, and devices for acquiring and analyzing various types of biological information including pulses, blood pressure, an electrocardiogram, respiration, and blood components may be arranged in the open space for associated treatment.

[0059] Working units may be retractably arranged in the open space by using existing technologies. Such working units may be retracted when not needed in operation, whereby the open space is opened so as to be fully accessible from outside.

INDUSTRIAL APPLICABILITY

[0060] The present invention is applicable to PET/MRI hybrid machines in general that combine a PET device and an MRI device, whereby functional information and morphological information can be simultaneously acquired from the same open space that is accessible from outside. This makes it possible to provide a highly useful open space suited to treatment and the like.

Claims

1. A PET/MRI hybrid machine that combines a PET device with an MRI device, comprising:

an open PET device that has a PET field of view at least part of which is an open space accessible from outside; and

an open MRI device that has an MRI field of view at least part of which is an open space accessible from outside, wherein

the open space of the PET field of view and the open space of the MRI field of view are allowed to overlap each other at least in part.

2. The PET/MRI hybrid machine according to claim 1, wherein two composite rings are opposed to each other with an open space accessible from outside therebetween so that the PET field of view and the MRI field of view are allowed to overlap each other in the open space, the two composite rings each including one of detector rings of the open PET device arranged in one of coils creating static magnetic field of the open MRI device.

3. The PET/MRI hybrid machine according to claim 2, wherein an MRI RF coil is fixed to or movably arranged on a bed that is insertable into the composite rings, and the RF coil and/or the bed are moved so that the RF coil enters the open space to allow the PET field of view and the MRI field of view to overlap each other.

4. The PET/MRI hybrid machine according to claim 3, wherein the RF coil is moved with respect to the bed and in a longitudinal direction of the bed so as to adjust the MRI field of view in position.

5. The PET/MRI hybrid machine according to any of claims 1 to 4, wherein a working unit is arranged in the open space.

6. The PET/MRI hybrid machine according to claim 5, wherein the working unit is retractably arranged in the open space.

7. The PET/MRI hybrid machine according to claim 5 or 6, wherein the working unit is any of an image acquisition unit, an irradiation device, and a general-purpose interventional treatment unit, or a combination thereof.

8. The PET/MRI hybrid machine according to claim 7, wherein the general-purpose interventional treatment unit includes at least any one of an automatic puncture device, an electromagnetic cautery needle, and a laparoscope.

9. The PET/MRI hybrid machine according to any of claims 5 to 8, wherein the same field of view is simultaneously imaged in three or more modalities.

10. The PET/MRI hybrid machine according to any of claims 5 to 9, wherein a PET and/or MRI image is acquired at least once both before and after operation of the working unit.

11. The PET/MRI hybrid machine according to any of claims 5 to 10, wherein a marking of a target position identified by a PET image that is acquired before operation of the working unit is put on a simultaneously-acquired MRI image, and the marking is displayed on a PET and/or MRI image acquired after

the operation of the working unit.

5

10

15

20

25

30

35

40

45

50

55

7

Fig. 1

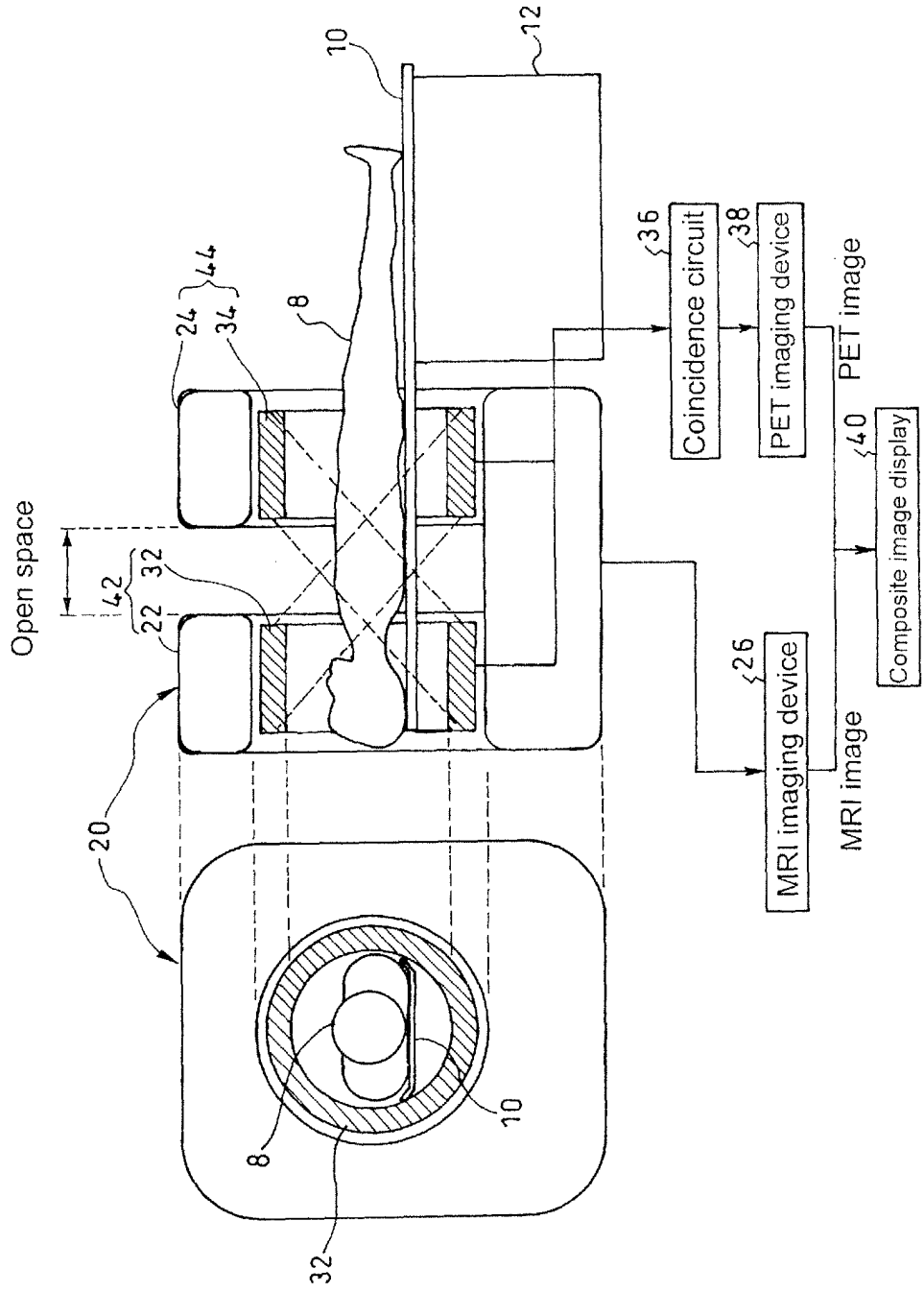

Fig. 2

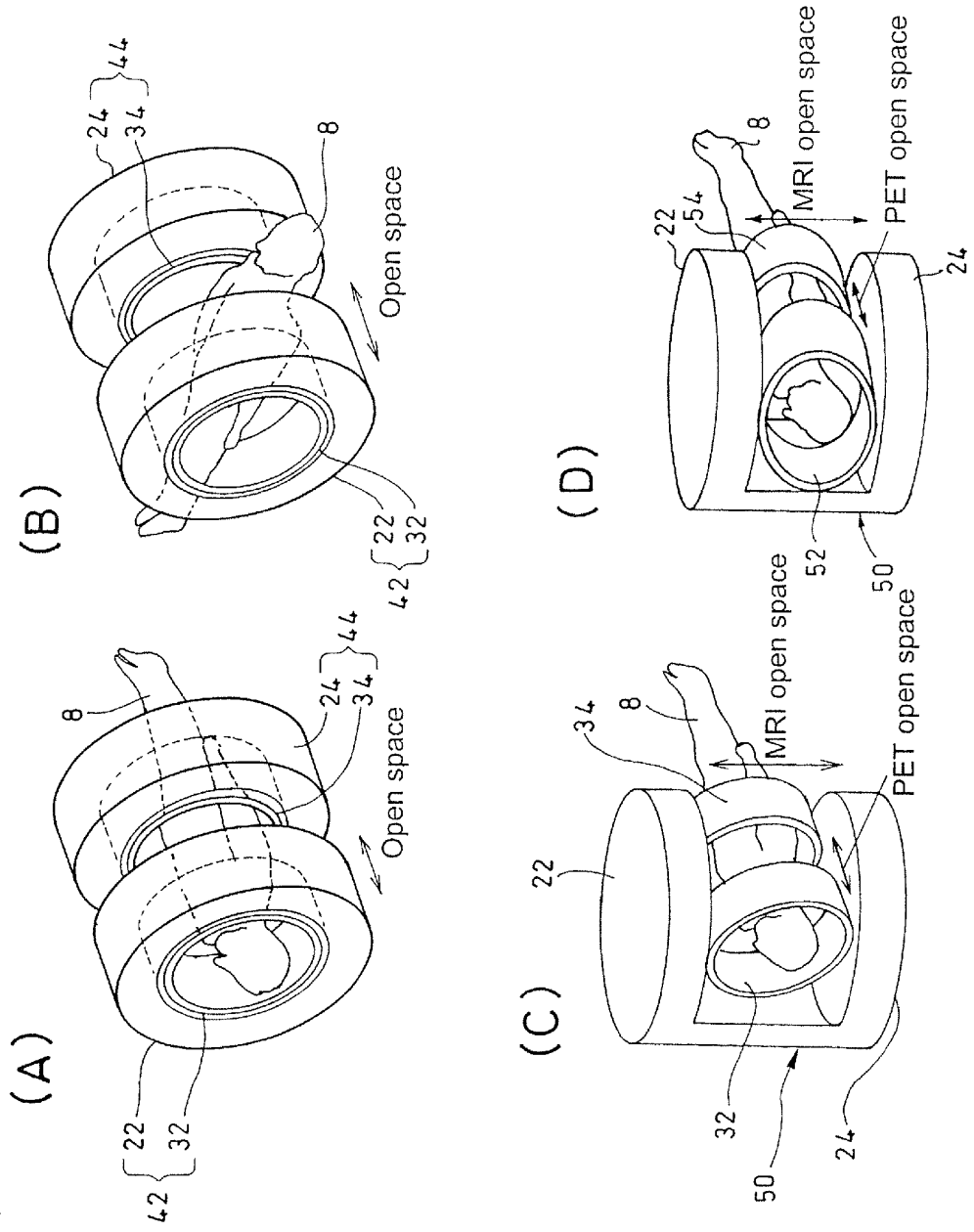

Fig. 3

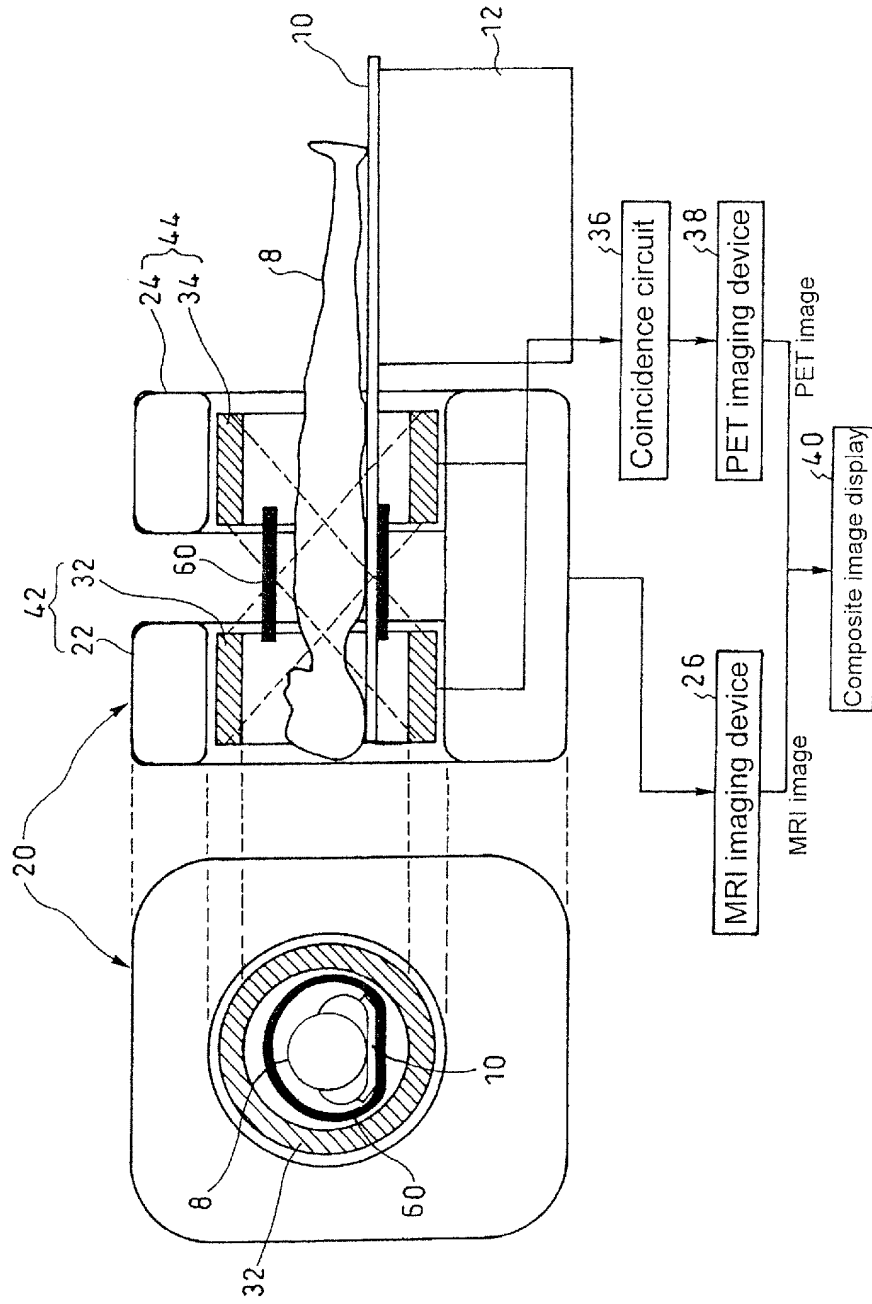

Fig. 4

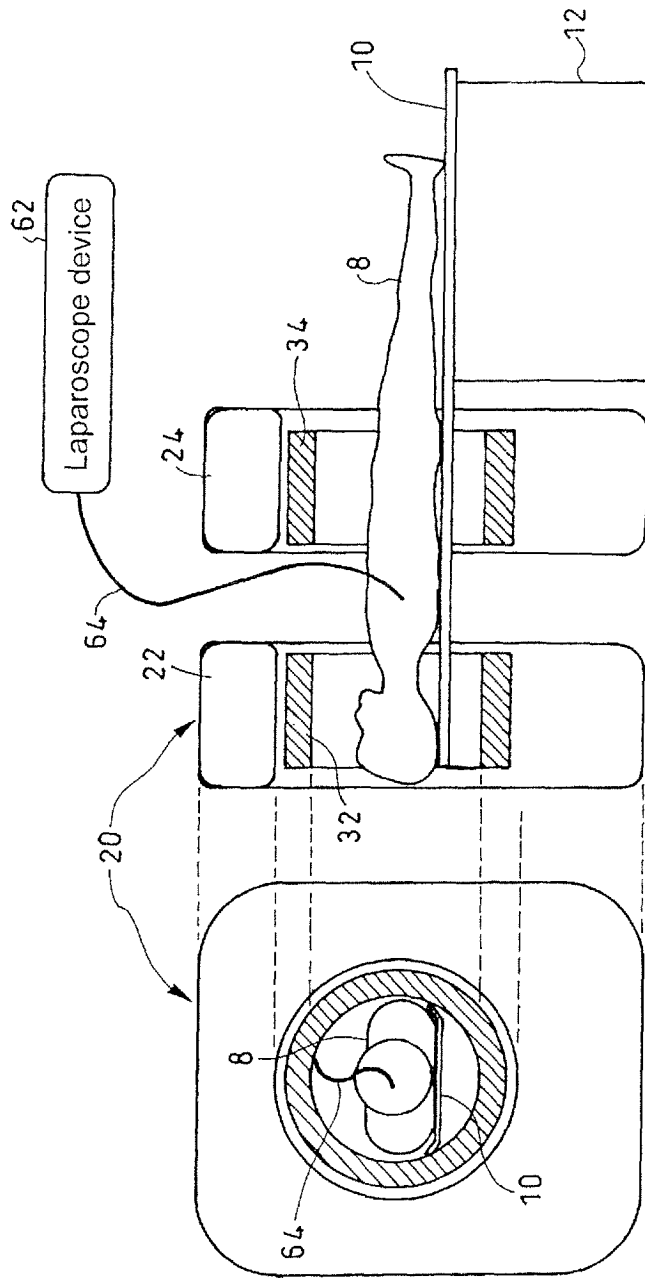

Fig. 5

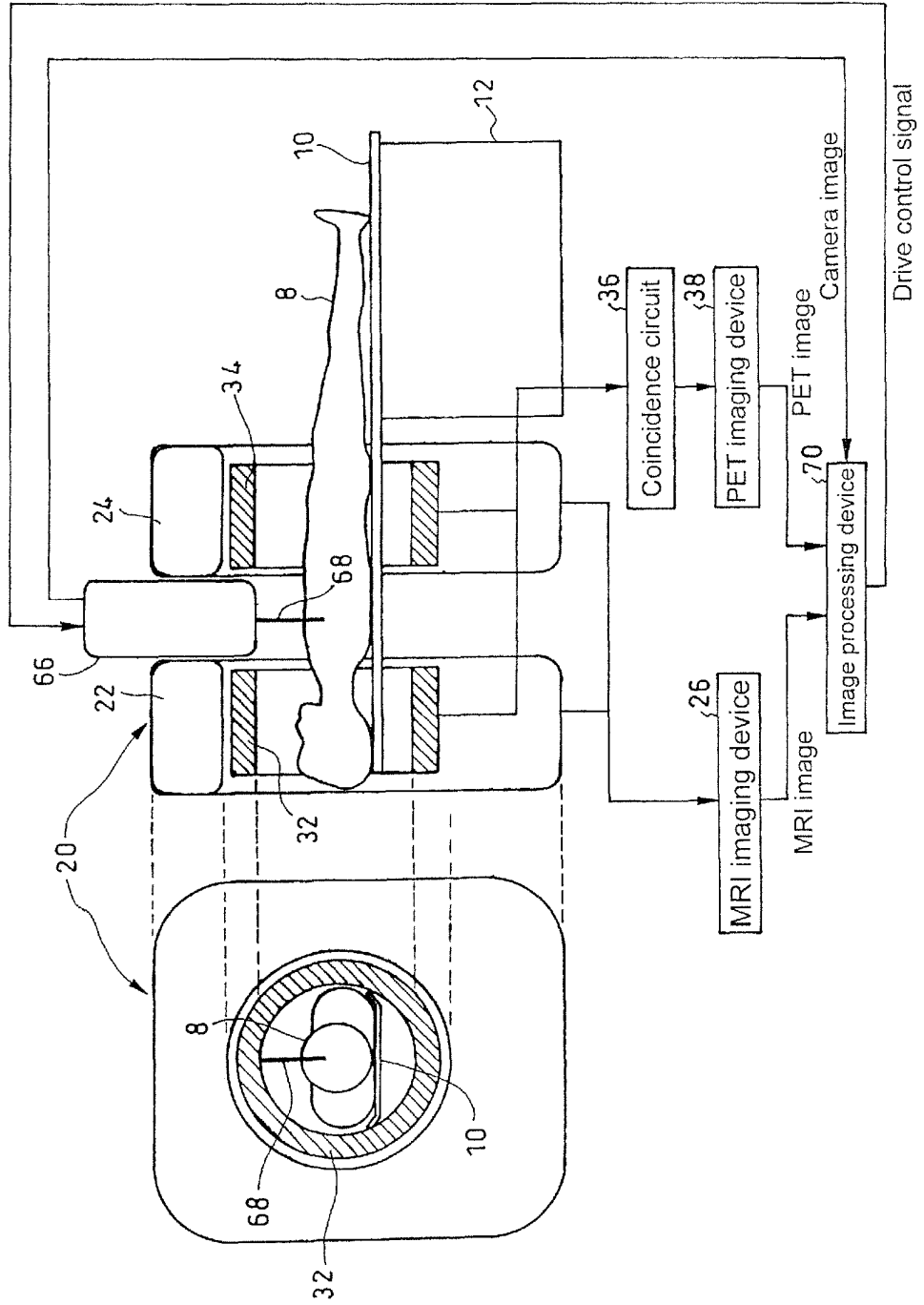

Fig. 7

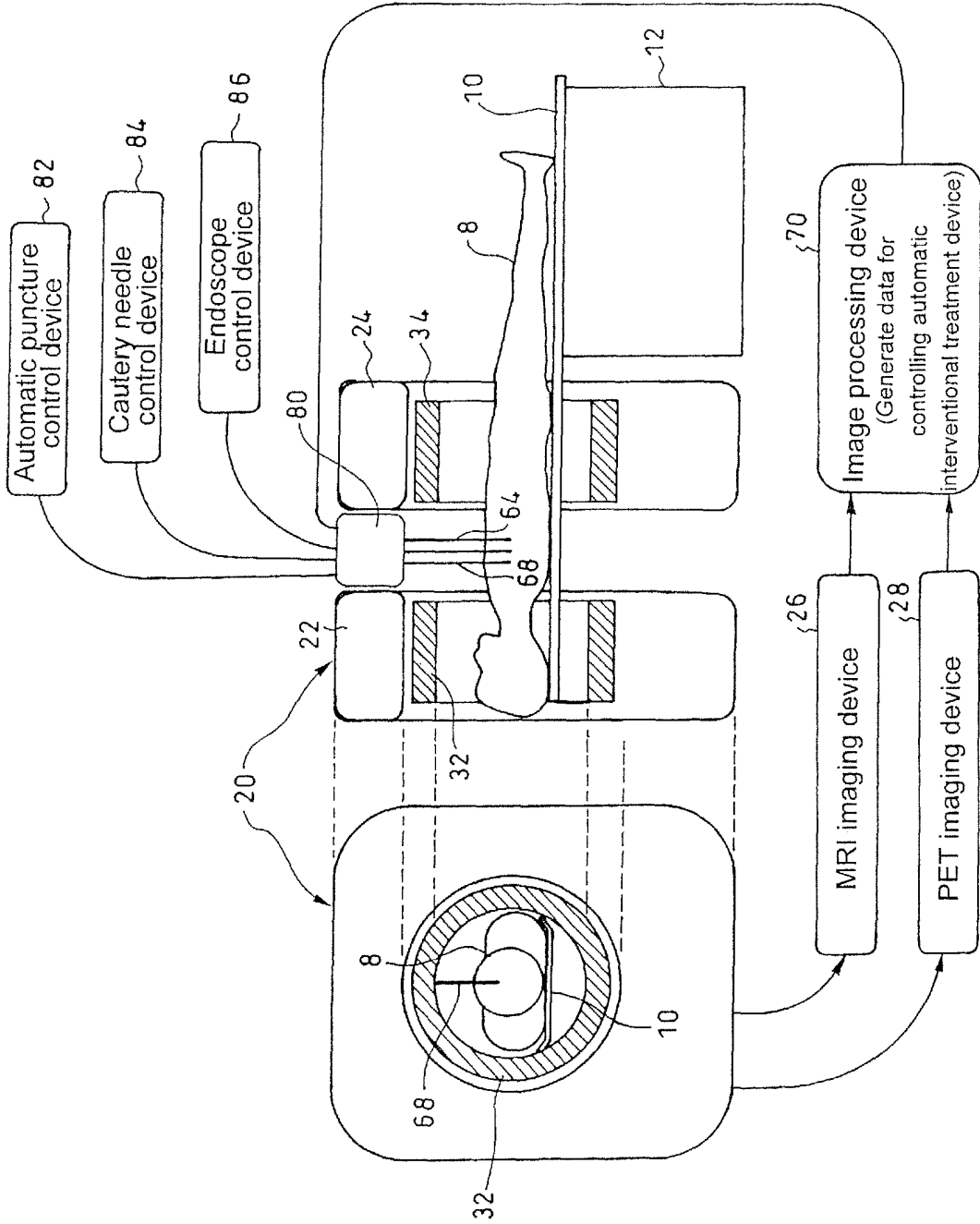

Fig. 8

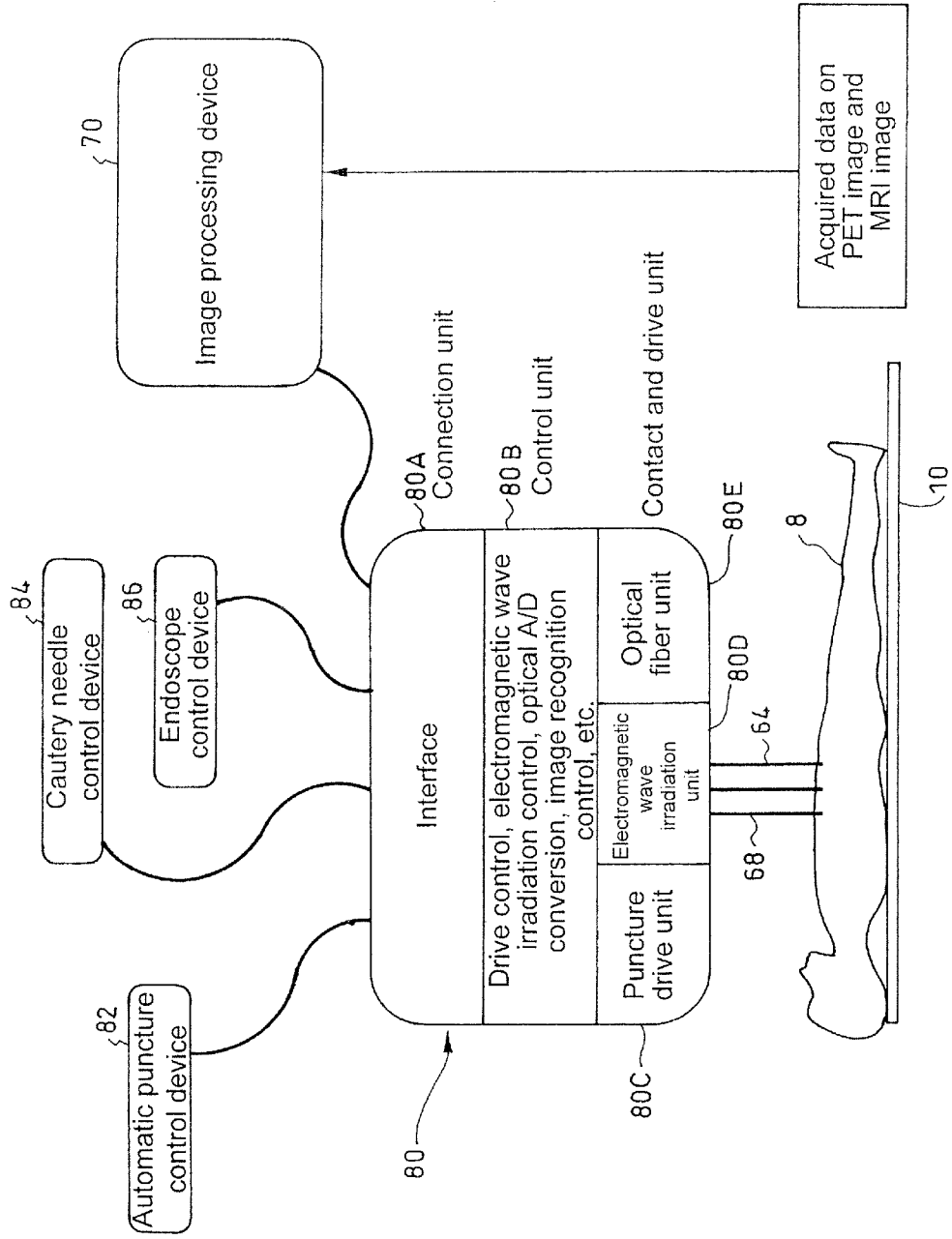

Fig. 9

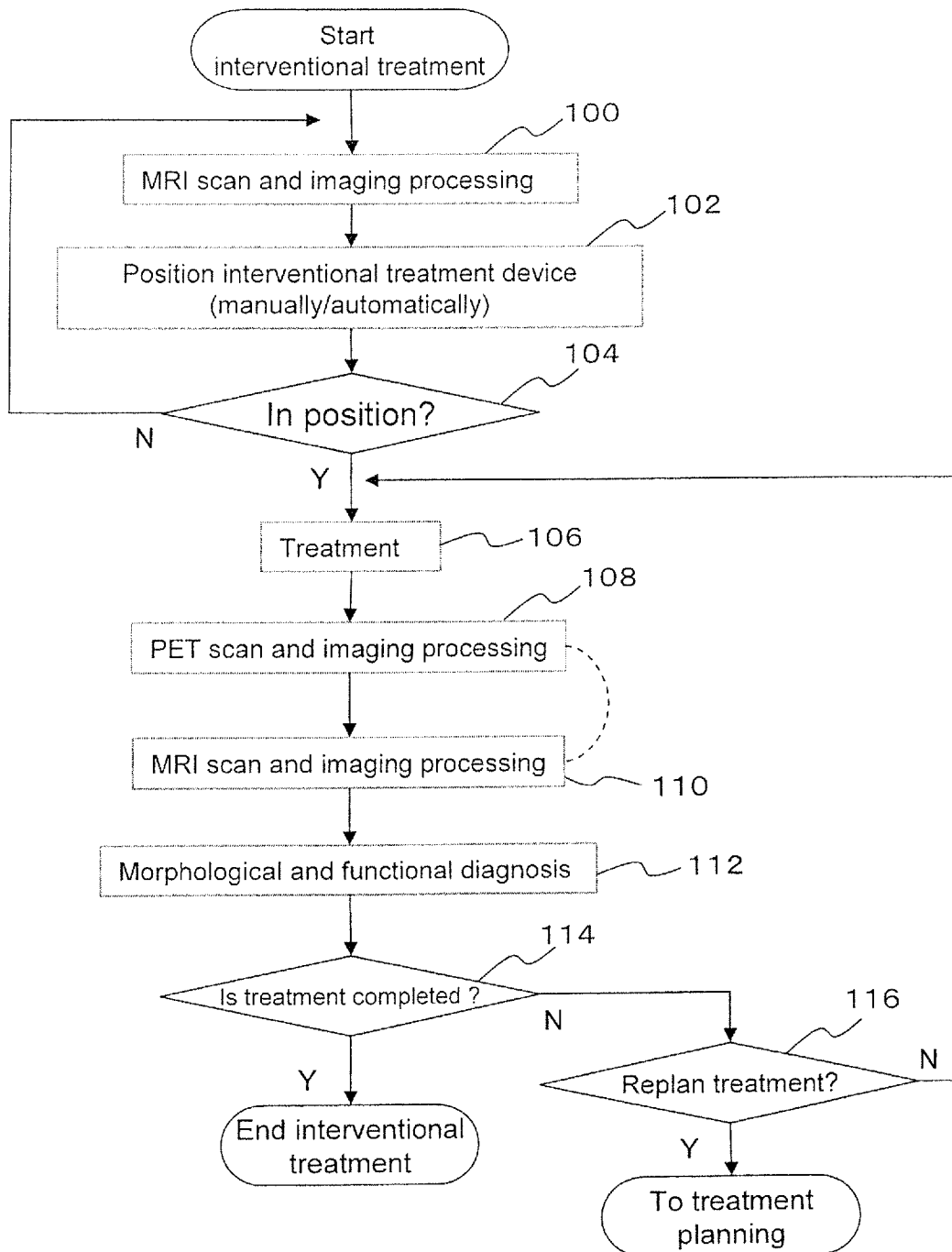

Fig. 10

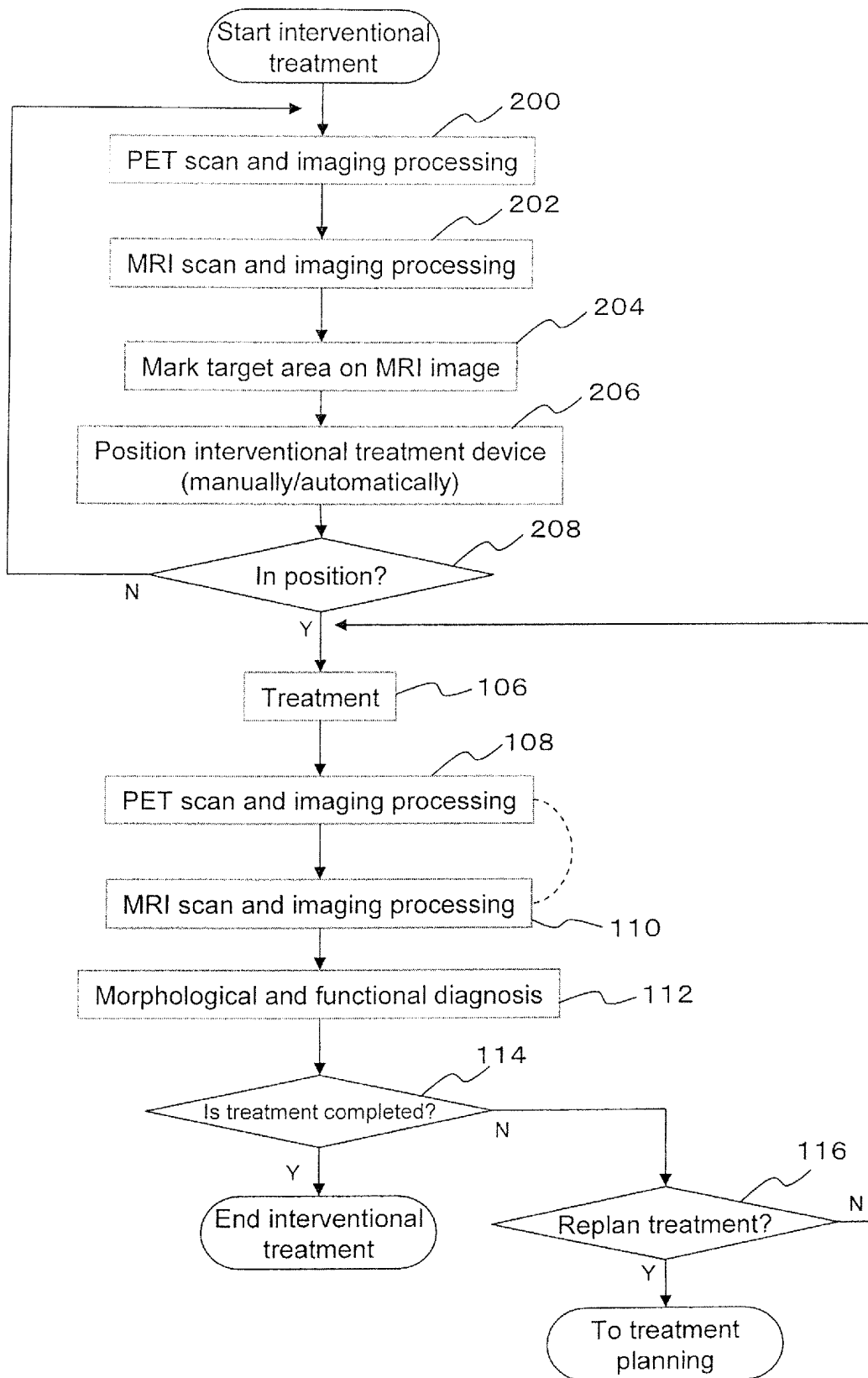
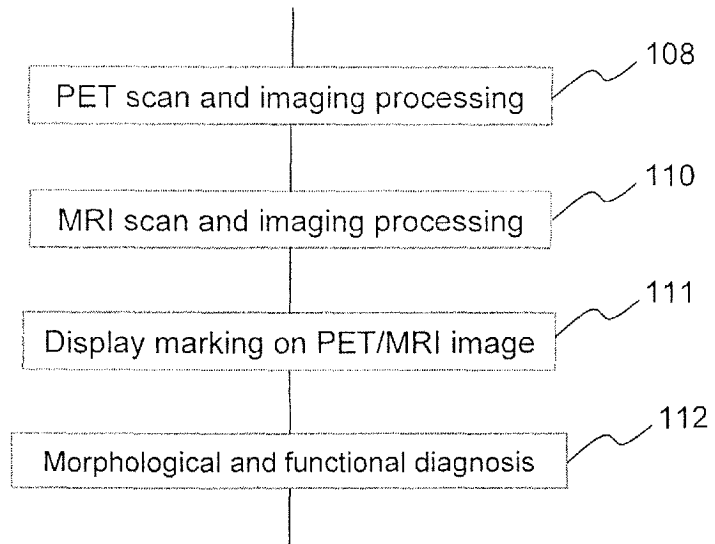

Fig. 11



INTERNATIONAL SEARCH REPORT

International application No.

PCT/JP2009/054780

<p>A. CLASSIFICATION OF SUBJECT MATTER <i>A61B5/055</i>(2006.01) i, <i>G01T1/161</i>(2006.01) i</p> <p>According to International Patent Classification (IPC) or to both national classification and IPC</p>																																
<p>B. FIELDS SEARCHED</p> <p>Minimum documentation searched (classification system followed by classification symbols) <i>A61B5/055</i>, <i>G01T1/161</i></p> <p>Documentation searched other than minimum documentation to the extent that such documents are included in the fields searched <i>Jitsuyo Shinan Koho</i> 1922-1996 <i>Jitsuyo Shinan Toroku Koho</i> 1996-2009 <i>Kokai Jitsuyo Shinan Koho</i> 1971-2009 <i>Toroku Jitsuyo Shinan Koho</i> 1994-2009</p> <p>Electronic data base consulted during the international search (name of data base and, where practicable, search terms used)</p>																																
<p>C. DOCUMENTS CONSIDERED TO BE RELEVANT</p> <table border="1"> <thead> <tr> <th>Category*</th> <th>Citation of document, with indication, where appropriate, of the relevant passages</th> <th>Relevant to claim No.</th> </tr> </thead> <tbody> <tr> <td>Y A</td> <td>JP 10-146341 A (Hitachi, Ltd.), 02 June, 1998 (02.06.98), Par. Nos. [0007], [0039], [0044], [0072] to [0076]; Fig. 5 & US 6094590 A</td> <td>1,5-11 2-4</td> </tr> <tr> <td>Y A</td> <td>Ciprian Catana, Simultaneous Acquisition of Multislice PET and MR Images: Initial Results with a MR-Compatible PET Scanner, The Journal of Nuclear Medicine, 2006. 12, Vol.47, No.12, p.1968-19761</td> <td>1,5-11 2-4</td> </tr> <tr> <td>Y</td> <td>JP 2002-526152 A (Regents of the University of Minnesota), 20 August, 2002 (20.08.02), Par. Nos. [0010], [0026] to [0029]; Figs. 1 to 2 & WO 2000/019927 A1</td> <td>11</td> </tr> </tbody> </table> <p><input checked="" type="checkbox"/> Further documents are listed in the continuation of Box C. <input type="checkbox"/> See patent family annex.</p> <table border="1"> <tr> <td>* Special categories of cited documents:</td> <td>"T" later document published after the international filing date or priority date and not in conflict with the application but cited to understand the principle or theory underlying the invention</td> </tr> <tr> <td>"A" document defining the general state of the art which is not considered to be of particular relevance</td> <td>"X" document of particular relevance; the claimed invention cannot be considered novel or cannot be considered to involve an inventive step when the document is taken alone</td> </tr> <tr> <td>"E" earlier application or patent but published on or after the international filing date</td> <td>"Y" document of particular relevance; the claimed invention cannot be considered to involve an inventive step when the document is combined with one or more other such documents, such combination being obvious to a person skilled in the art</td> </tr> <tr> <td>"L" document which may throw doubts on priority claim(s) or which is cited to establish the publication date of another citation or other special reason (as specified)</td> <td>"&" document member of the same patent family</td> </tr> <tr> <td>"O" document referring to an oral disclosure, use, exhibition or other means</td> <td></td> </tr> <tr> <td>"P" document published prior to the international filing date but later than the priority date claimed</td> <td></td> </tr> </table> <table border="1"> <tr> <td>Date of the actual completion of the international search 30 March, 2009 (30.03.09)</td> <td>Date of mailing of the international search report 07 April, 2009 (07.04.09)</td> </tr> <tr> <td>Name and mailing address of the ISA/ Japanese Patent Office</td> <td>Authorized officer</td> </tr> <tr> <td>Facsimile No.</td> <td>Telephone No.</td> </tr> </table>			Category*	Citation of document, with indication, where appropriate, of the relevant passages	Relevant to claim No.	Y A	JP 10-146341 A (Hitachi, Ltd.), 02 June, 1998 (02.06.98), Par. Nos. [0007], [0039], [0044], [0072] to [0076]; Fig. 5 & US 6094590 A	1,5-11 2-4	Y A	Ciprian Catana, Simultaneous Acquisition of Multislice PET and MR Images: Initial Results with a MR-Compatible PET Scanner, The Journal of Nuclear Medicine, 2006. 12, Vol.47, No.12, p.1968-19761	1,5-11 2-4	Y	JP 2002-526152 A (Regents of the University of Minnesota), 20 August, 2002 (20.08.02), Par. Nos. [0010], [0026] to [0029]; Figs. 1 to 2 & WO 2000/019927 A1	11	* Special categories of cited documents:	"T" later document published after the international filing date or priority date and not in conflict with the application but cited to understand the principle or theory underlying the invention	"A" document defining the general state of the art which is not considered to be of particular relevance	"X" document of particular relevance; the claimed invention cannot be considered novel or cannot be considered to involve an inventive step when the document is taken alone	"E" earlier application or patent but published on or after the international filing date	"Y" document of particular relevance; the claimed invention cannot be considered to involve an inventive step when the document is combined with one or more other such documents, such combination being obvious to a person skilled in the art	"L" document which may throw doubts on priority claim(s) or which is cited to establish the publication date of another citation or other special reason (as specified)	"&" document member of the same patent family	"O" document referring to an oral disclosure, use, exhibition or other means		"P" document published prior to the international filing date but later than the priority date claimed		Date of the actual completion of the international search 30 March, 2009 (30.03.09)	Date of mailing of the international search report 07 April, 2009 (07.04.09)	Name and mailing address of the ISA/ Japanese Patent Office	Authorized officer	Facsimile No.	Telephone No.
Category*	Citation of document, with indication, where appropriate, of the relevant passages	Relevant to claim No.																														
Y A	JP 10-146341 A (Hitachi, Ltd.), 02 June, 1998 (02.06.98), Par. Nos. [0007], [0039], [0044], [0072] to [0076]; Fig. 5 & US 6094590 A	1,5-11 2-4																														
Y A	Ciprian Catana, Simultaneous Acquisition of Multislice PET and MR Images: Initial Results with a MR-Compatible PET Scanner, The Journal of Nuclear Medicine, 2006. 12, Vol.47, No.12, p.1968-19761	1,5-11 2-4																														
Y	JP 2002-526152 A (Regents of the University of Minnesota), 20 August, 2002 (20.08.02), Par. Nos. [0010], [0026] to [0029]; Figs. 1 to 2 & WO 2000/019927 A1	11																														
* Special categories of cited documents:	"T" later document published after the international filing date or priority date and not in conflict with the application but cited to understand the principle or theory underlying the invention																															
"A" document defining the general state of the art which is not considered to be of particular relevance	"X" document of particular relevance; the claimed invention cannot be considered novel or cannot be considered to involve an inventive step when the document is taken alone																															
"E" earlier application or patent but published on or after the international filing date	"Y" document of particular relevance; the claimed invention cannot be considered to involve an inventive step when the document is combined with one or more other such documents, such combination being obvious to a person skilled in the art																															
"L" document which may throw doubts on priority claim(s) or which is cited to establish the publication date of another citation or other special reason (as specified)	"&" document member of the same patent family																															
"O" document referring to an oral disclosure, use, exhibition or other means																																
"P" document published prior to the international filing date but later than the priority date claimed																																
Date of the actual completion of the international search 30 March, 2009 (30.03.09)	Date of mailing of the international search report 07 April, 2009 (07.04.09)																															
Name and mailing address of the ISA/ Japanese Patent Office	Authorized officer																															
Facsimile No.	Telephone No.																															

INTERNATIONAL SEARCH REPORT

International application No. PCT/JP2009/054780
--

C (Continuation). DOCUMENTS CONSIDERED TO BE RELEVANT		
Category*	Citation of document, with indication, where appropriate, of the relevant passages	Relevant to claim No.
A	JP 9-211130 A (Shizuoka-Ken, Hamamatsu Photonics Kabushiki Kaisha), 15 August, 1997 (15.08.97), Par. No. [0013]; Fig. 17 (Family: none)	1-11

REFERENCES CITED IN THE DESCRIPTION

This list of references cited by the applicant is for the reader's convenience only. It does not form part of the European patent document. Even though great care has been taken in compiling the references, errors or omissions cannot be excluded and the EPO disclaims all liability in this regard.

Non-patent literature cited in the description

- **Ciprian Catana et al.** Simultaneous Acquisition of Multislice PET and MR Images: Initial Results with a MR-Compatible PET Scanner. *The Journal of Nuclear Medicine*, December 2006, vol. 47 (12), 1968-1976 [0003]
- **Joshua Lilienstien et al.** In Vivo Sonography Through an Open MRI Breast Coil to Correlate Sonographic and MRI Findings. *AJR*, March 2005, vol. 184, 49-52 [0005]
- **Hiroshi Iseki et al.** Intelligent Operating Theater Using Intraoperative Open-MRI. *Magnetic Resonance in Medical Sciences*, 2005, vol. 4 (3), 129-136 [0005]
- **Junta Harada et al.** Initial Experience of Percutaneous Renal Cryosurgery under the Guidance of a Horizontal Open MRI System. *Radiation Medicine*, 2001, vol. 19 (6), 291-296 [0005]
- **DiMaio SP et al.** Robot-assisted needle placement in open MRI: system architecture, integration and validation. *Comput Aided Surg.*, January 2007, vol. 12 (1), 15-24 [0005]
- **DiMaio SP et al.** Robot-assisted needle placement in open MRI: system architecture, integration and validation. *Stud Health Technol Inform.*, 2006, vol. 119, 126-31 [0005]
- **Taiga Yamaya ; Taku Inaniwa ; Shinichi Minohara ; Eiji Yoshida ; Naoko Inadama ; Fumihiko Nishikido ; Kengo Shibuya ; Chih Fung Lam ; Hideo Murayama.** A proposal of an open PET geometry. *Phy. Med. Biol.*, 2008, vol. 53, 757-773 [0006]

专利名称(译)	打开pet-MRI复合机		
公开(公告)号	EP2407101A4	公开(公告)日	2012-12-05
申请号	EP2009841472	申请日	2009-03-12
申请(专利权)人(译)	国家研究所放射科学		
当前申请(专利权)人(译)	国家研究所放射科学		
[标]发明人	YAMAYA TAIGA MURAYAMA HIDEO OBATA TAKAYUKI AOKI ICHIO		
发明人	YAMAYA, TAIGA MURAYAMA, HIDEO OBATA, TAKAYUKI AOKI, ICHIO		
IPC分类号	A61B5/055 G01T1/161 G01R33/48 G01R33/38 G01T1/16		
CPC分类号	G01R33/481 G01R33/3806 G01R33/381 G01T1/1603		
其他公开文献	EP2407101B1 EP2407101A1		
外部链接	Espacenet		

摘要(译)

将PET装置与MRI装置组合的PET / MRI混合机器包括：具有PET视野的开放式PET装置，其至少一部分是从外部接近的开放空间；具有MRI视野的开放式MRI设备，其至少一部分是从外部接近的开放空间，并且允许PET视野的开放空间和MRI视野的开放空间重叠。其他至少部分。这使得可以同时测量和成像由PET装置和MRI装置从外部可访问的相同开放空间，从而同时获取功能信息和形态信息。

