

(19)



(11)

EP 2 355 717 B1

(12)

EUROPEAN PATENT SPECIFICATION

(45) Date of publication and mention of the grant of the patent:
19.02.2014 Bulletin 2014/08

(51) Int Cl.:
A61B 17/22^(2006.01) A61B 17/221^(2006.01)

(21) Application number: **09830998.2**

(86) International application number:
PCT/US2009/066281

(22) Date of filing: **01.12.2009**

(87) International publication number:
WO 2010/065556 (10.06.2010 Gazette 2010/23)

(54) **Systems for capturing and removing urinary stones from body cavities**

Systeme zur Erfassung und Entfernung von Harnsteinen aus Körperhöhlräumen

Systèmes pour capturer et éliminer des calculs urinaires de cavités corporelles

(84) Designated Contracting States:
AT BE BG CH CY CZ DE DK EE ES FI FR GB GR HR HU IE IS IT LI LT LU LV MC MK MT NL NO PL PT RO SE SI SK SM TR
Designated Extension States:
AL BA RS

• **BEHL, Robert S.**
Palo Alto
California 94306 (US)

(30) Priority: **01.12.2008 US 118802 P**
16.04.2009 US 170055 P

(74) Representative: **MacDougall, Alan John Shaw et al**
Mathys & Squire LLP
120 Holborn
London
EC1N 2SQ (GB)

(43) Date of publication of application:
17.08.2011 Bulletin 2011/33

(56) References cited:
WO-A1-2005/079678 WO-A2-01/80748
WO-A2-2008/028149 DE-A1- 19 722 429
US-A- 4 739 760 US-A- 4 920 954
US-A- 5 041 093 US-A- 5 716 321
US-A- 6 071 233 US-A1- 2003 023 247
US-A1- 2005 033 172 US-A1- 2005 049 619
US-A1- 2005 059 981 US-A1- 2005 165 412
US-A1- 2007 203 475 US-A1- 2008 058 836
US-B1- 6 210 370 US-B1- 6 264 664
US-B1- 6 443 159 US-B1- 6 800 080

(73) Proprietor: **Percutaneous Systems, Inc.**
Palo Alto, California 94304 (US)

(72) Inventors:
• **DESAI, Rupesh**
San Jose
California 95132 (US)
• **YEE, Steven**
Sunnyvale
California 94086 (US)

EP 2 355 717 B1

Note: Within nine months of the publication of the mention of the grant of the European patent in the European Patent Bulletin, any person may give notice to the European Patent Office of opposition to that patent, in accordance with the Implementing Regulations. Notice of opposition shall not be deemed to have been filed until the opposition fee has been paid. (Art. 99(1) European Patent Convention).

Description

BACKGROUND OF THE INVENTION

[0001] 1. Field of the invention. The present invention relates generally to medical apparatus. More particularly, the present invention relates to a method and apparatus for capturing, fragmenting, and removing urinary stones from the kidney or bladder.

[0002] Urinary tract endoscopy, a minimally invasive procedure for removing urinary stones that are present in the bladder, ureter, or kidney, may be performed in several ways. A large viewing scope, referred to as a cystoscope, is advanced from the urethra into the bladder. When necessary, a smaller ureteroscope is further advanced from the bladder, through the ureter, and into the kidney. Alternatively, a nephroscope entering through a percutaneous tract into the kidney, may be used in the kidney and upper urinary tract. In each of these protocols, endoscopes carry either an optical element or optical fiber bundle which in some cases are steerable so that individual stones may be observed, captured, and removed from the kidney and bladder. The endoscopes carry a working channel for the introduction of tools to the distal end of the device. The working channel in a ureteroscope, however, has a very small diameter, due to the very small size of the device itself, typically limiting tool use to one small tool at a time. Optionally, the stones may be fragmented using laser or other energy, and the intact stone and/or fragments may be removed using a deployable basket advanced through a working channel of the endoscope.

[0003] Endoscopic stone treatment is particularly difficult to perform in the bladder and kidney where the stones or stone fragments may be mobile and are present in a large open volume and thus are often difficult to capture. While the stones may be captured using a basket or other tools under direct visualization, steering the scope and firmly capturing the stone is problematic, particularly if the stone is mobile and suspended within the open volume. Moreover, if the stone is fragmented with energy, capturing the many stone fragments which disperse throughout the volume and can be even more difficult and time consuming.

[0004] For these reasons, it would be desirable to provide improved and alternative apparatus and protocols for the ureteroscopic treatment and removal of stones from the urinary system, particularly the kidney and bladder. Such systems and protocols will preferably be compatible with many or all conventional endoscopes which are commercially available. Desirably, the apparatus and protocols will facilitate capturing of the stones within the open volumes of the kidney and bladder, will allow for energy-based fragmentation of the stones while they remain captured, and will contain most or all of the stone fragments resulting from the fragmentation. The apparatus and protocols would preferably reduce the need to use the working channel of the endoscope, making the

working channel available for an energy source or use in new protocols. At least some of these objectives will be met by the inventions described below.

[0005] 2. Background of the Background Art. Dr. Bogdan Petrut has filed a Romanian Patent Application describing a stone capture device for attaching to a ureteroscope to capture and draw stones into a sheath for containing the stones while delivering laser energy to break up the stones. See also U.S. Patent Nos. 3,760,810; 3,870,048; 4,222,308; 4,257,420; 4,471,766; 4,735,194; 5,423,834; 5,507,797; 6,099,535; 6,645,195; 6,869,395; 7,204,804; and 7,223,230. U.S. Patent Publication No. US 2006/0116693 describes a stone capture device intended for use in lithotripsy treatment. The Roth-Net® foreign body retrieval device is described at <http://www.usendoscopy.com/foreignbody.php>.

[0006] US 6,264,664 discloses a surgical basket instrument that includes a sheath (catheter), a shaft extending through and axially movable relative to the sheath, a basket assembly coupled to a distal end of the shaft, and a handle coupled to a proximal end of the shaft and adapted for facilitating movement of the shaft relative to the sheath such that the basket assembly may be moved out of and into the distal end of the sheath. The basket assembly is formed from a plurality of circumferentially spaced flexible wires or cables which facilitate entrapping of urological and gastrointestinal calculi. The shaft is made of a hollow compacted cable formed from a flexible yet strong shape memory material such as a nickel-titanium alloy. The hollow (channel) in the shaft receives at least one fiber optic couplable to a laser beam for destroying calculi. The fiber optic may be stationary or axially movable relative to the shaft, and may extend to the proximal end of the basket assembly or beyond the distal tip of the instrument so as to act as a sphinctertome. Additional fiber optics which extend through the channel, and a fluid source coupled to the channel permit the basket instrument to have the additional functionality of an endoscope.

[0007] US 5,71,6321 discloses a method and apparatus for imaging a narrow body lumen, the method comprising maintaining separation between a distal end of an optical viewing scope and a lumen wall with a spacing structure which extends distally from the distal end of an access catheter. Optional spacing structures include distal cages and a guidewire which is fixed to and extends distally from the access catheter body. The device can be used during retrograde imaging of the fallopian tube, as it prevents the tubal wall from coming into such close proximity to a falloposcope as to produce "whiteout" on the imaging monitor.

[0008] US 6,443,159 discloses a method of exposing, ligating, and dividing perforating veins endoscopically using balloon dissectors to gain access to the perforating veins thereby avoiding large incisions required in the Linton procedure and similar open surgical procedures.

[0009] US 2005/0049619 discloses a system for removing an obstruction from a blood vessel that includes

an obstruction engaging element and an expandable capture element. The capture element has a flexible cover and an expandable support structure. The engaging element engages the obstruction and moves the obstruction into the capture element. The capture element protects the obstruction when the obstruction is moved into the catheter.

[0010] Document WO 2005/079678 A discloses a stone capture device with an inner through going lumen suitable for use with a steerable viewing scope comprising a sheath having a distal end, a proximal end, and a lumen positionable over a shaft of a viewing scope and a perforate sweeping structure extending distally from the distal end of the sheath, wherein the perforate sweeping structure is shiftable between a tubular configuration with a width about the same as that of the sheath and a concave configuration which increases in width in the distal direction, wherein a distal end of a steerable viewing scope can be disposed within the concave sweeping structure when deployed.

BRIEF SUMMARY OF THE INVENTION

[0011] The present invention provides a stone capture device as set out in the appended claims.

[0012] The application also discloses methods for removing urinary stones from a body cavity, such as a kidney or bladder. The methods comprise introducing a viewing scope, such as a commercially available ureteroscope, having an optical element at its end into an open volume of the body cavity. A perforate sweeping structure is deployed from a distal end of the viewing scope, while the viewing scope is steered and advanced within the open volume of the body cavity to engage the deployed perforate sweeping structure against the stone. Once the stone is engaged, the sweeping structure is further advanced to urge the stone against a wall structure of the body cavity so that the stone is captured between the sweeping structure and the wall structure. Energy is then applied through the viewing scope, typically laser energy delivered via an optical (laser) fiber advanced through a working channel of the viewing scope. The delivered energy disrupts the captured stone and large fragments, producing smaller stone fragments. Usually, the stone is held in place while delivering energy solely by the sweeping structure against the wall structure, and no separate basket, forceps, loop structures, or the like, are used to hold the stone in place. In a preferred method, the region around the captured stone is irrigated, typically before, during, and/or after the energy-based fragmentation, to wash the stone fragments into the sweeping structure. Preferred sweeping structures comprise mesh structures, often double-walled mesh structures, in which the stone fragments become entrapped as they are washed away by the irrigating solution.

[0013] The viewing scope is usually introduced trans-luminally, i.e. through the urethra and optionally through the bladder, ureter, and into the kidney. Alternatively,

however, the sweeping structure and viewing scope could be introduced through a percutaneous incision in the abdomen.

[0014] During delivery and prior to deployment, the perforate sweeping structure is usually maintained in a tubular configuration. Such a tubular structure may be deployed by axial foreshortening. The sweeping structure is disposed over a distal portion of the viewing scope, where the tubular configuration is transformed into a concave structure which extends distally from the distal end of the viewing scope. The concave structure, which may be conical, hemispherical, or have other expansibly tapered structures, will surround the optical element of the viewing scope so that view from the element is not obscured. Moreover, the tubular configuration of the sweeping structure will typically be sufficiently flexible so that the distal end or region of the viewing scope can be steered in a conventional manner without excessive constraint by the sweeping structure. When the tubular configuration of the sweeping structure is shifted to the concave structure, however, it will become more rigid, allowing it to engage, move, and entrap kidney stones against the body cavity wall while retaining sufficient flexibility to conform to an irregularly shaped wall surface. While a preferred perforate sweeping structure is deployed by foreshortening, alternative sweeping structures may have an initial collapsed, closed configuration extending over the distal end of the viewing structure and may be deployed or otherwise opened to a concave configuration surrounding the distal end of the viewing structure, typically by releasing the constrained structure from a surrounding sleeve or other structure.

[0015] The methods described herein optionally include steering the viewing scope within the body cavity while the distal portion of the viewing scope is present within the tubular configuration of the sweeping structure. Methods further comprise engaging the perforate structure against the urinary stones when said structure is sufficiently rigid to manipulate the stones while remaining sufficiently flexible to conform an outer rim of the structure to an irregularly shaped bladder wall and sufficiently porous to allow fluids to pass freely through the perforations or apertures in the perforate structure when the region is being irrigated. Generally, the perforate sweeping structure will be formed as a metal or polymeric mesh with individual interwoven wires or filaments. The mesh will have openings or interstices which are sufficiently large to allow the free flow of irrigation fluid, but which have dimensions which contain and/or entrap the stone fragments within the mesh, particularly within a double walled mesh structure which will be described hereinbelow. Usually, porosity of the deployed perforate structure will be sufficient to limit stones larger than 2 mm in any dimension from passing therethrough. The deployed perforate structure utilizes irrigation from the viewing scope to maintain the captured stone fragments (typically smaller than 2mm) against the interior of the perforate structure and/or against the wall of the body cavity so as not to

obscure vision during lithotripsy procedures.

[0016] Usually, the perforate sweeping structure will be removably attached to the distal end of the viewing scope. Thus, after the assembly viewing scope and perforate structure has been used in a procedure, the perforate sweeping structure may be detached from the assembly and disposed of while the viewing scope may be sterilized and reused.

[0017] While the presently preferred perforate sweeping structure will be an evertable tubular structure, as described above, other embodiments of the perforate sweeping structure include a self-expanding tube or other elongate structure which can be distally advanced from a carrier sleeve or sheath. Usually, the carrier sleeve or sheath will be configured as a "monorail" device which has a relatively short engagement length, typically from 2 cm to 10 cm, usually from 3 cm to 8 cm, with a lumen or passage therethrough which receives the viewing scope. Thus, the carrier sleeve may be advanced over a proximal end of the viewing scope in a manner similar to a monorail vascular catheter. A hypotube or other elongate shaft is attached at the proximal end of the carrier sleeve allowing the carrier sleeve to be pushed over the viewing scope until the sleeve reaches the distal end of the scope. At that point, a second pusher rod or element is used to distally advance a conical (tapered to open in the distal direction) or other expanding mesh structure from the carrier sleeve, where the structure will be configured so that a proximal end is aligned with the optical viewing element of the viewing scope. The assembly of the viewing scope and the carrier sleeve with deployed perforate sweeping structure then can be manipulated and advanced within the open volume of the body cavity to capture stones and engage the stones against a structure, typically a wall of the body lumen, prior to delivering energy to break up the stones. After the stones are broken up, the perforate structure may be proximally retracted so that the structure as well as the stones carried therein are drawn back into the carrier sleeve which may then be withdrawn from the body cavity to remove the stone fragments.

[0018] In one aspect of the present invention, a stone capture device for use with a steerable viewing scope comprises a sheath and a perforate sweeping structure. The sheath has a distal end, a proximal end, and a lumen therebetween, where the lumen is positionable over the distal end of the viewing scope. Usually, the sheath will have a length which extends over most, but not all of the length of the viewing structure, allowing a proximal end of the sheath to be available for manipulation by the treating physician during a procedure. That is, the sheath will have a length sufficient to allow the proximal end of the sheath to lie outside of the patient even when the distal end has been fully advanced into the kidney. Usually, the sheath length will be in the range from 20 cm to 100 cm, more usually from 60 cm to 70 cm when configured for use with a relatively long ureteroscope, and will be in the range from 10 cm to 50 cm, usually from 30 cm to 35 cm

when configured to work with a shorter cystoscope or nephroscope.

[0019] The perforate sweeping structure will be removably attached to and extend distally from the distal end of the sheath. The perforate sweeping structure will be shiftable between a tubular configuration with a width generally about the same as that of the sheath and a concave configuration which increases in width in the distal direction. A distal end of the viewing scope is disposed within the concave sweeping structure when said sweeping structure is deployed. Prior to deployment, the sweeping structure may be positioned proximally to the distal end of the viewing scope to enhance visibility and/or maneuverability of the distal scope tip. Usually, an optical element of the viewing scope will be generally centered within the deployed sweeping structure. Optionally, the stone capture device may further comprise a means for closing a distal end of the deployed concave sweeping structure to capture the stones therein. Conveniently, the closing means may be a simple wire, suture, or other loop or tether which extends around the distal end of the deployed concave sweeping structure. Thus, the tether can be drawn to close the distal end in the manner of a "purse string." The sweeping structure typically comprises woven or braided filaments which form a mesh tube which can be foreshortened to evert to form a double-walled concave structure. The double-walled concave structure will usually have a conical or hemispherical geometry, typically being advanceable over the viewing scope, typically in a monorail fashion, the position the sweeping structure in the bladder or kidney.

[0020] The perforate sweeping structure is attached to the distal end of the viewing scope and the sheath will typically be configured to position the perforate sweeping structure distally over a distal region of the viewing scope while the sweeping structure is in its tubular configuration. By drawing the viewing scope proximally, where the viewing scope is connected to a distal end of the tubular sweeping structure, the tubular configuration of the sweeping structure will be deformed to assume a concave configuration where all or a principal portion of the concave configuration is positioned distally of the distal end of the viewing structure. In its tubular configuration, the sweeping structure will be sufficiently flexible and bendable to allow steering of the viewing structure within the sweeping structure prior to deployment. After deployment into its concave configuration, however, the sweeping structure will assume its double-walled configuration and will have sufficient stiffness to engage and manipulate stones within the body cavity so that the stones may be urged against a cavity wall. Typically, the sweeping structure in its concave configuration will have a bending stiffness which is at least 25% greater than that in the tubular configuration, usually being at least 50% greater, and often being 100% greater or more. The sweeping structure in its concave configuration will further have a width which is greater than that of the sheath, typically being at least twice that of the sheath, often up to eight-

fold larger than the sheath width.

[0021] The stone capture device is typically packaged as a kit where the sheath and perforate sweeping structure are attached to each other, sterilized, and present in a sterile package, such as a bag, tube, or box. The stone capture device is thus ready to be removably attached to the distal end of a conventional or commercially available viewing scope, such as a ureteroscope, where a distal portion of the scope is placed within the perforate sweeping structure of the capture device. The distal end of the scope will typically be secured to the distal tip of the tubular configuration of the perforate sweeping structure so that retraction of the viewing scope relative to the sheath will foreshorten the perforate sweeping structure causing it to assume the concave configuration.

BRIEF DESCRIPTION OF THE DRAWINGS

[0022]

Fig. 1 is a perspective view of a stone capture device constructed in accordance with the principles of the present invention.

Fig. 2 is a perspective view of a viewing scope in the form of a commercially available ureteroscope having a steerable distal end.

Fig. 3 is a detailed view of the distal end of the stone capture device of the present invention.

Figs. 4A and 4B illustrate the distal end of the stone capture device with a partially deployed sweeping structure.

Fig. 5A and 5B illustrate the distal end of the stone capture device with a fully deployed sweeping structure.

Fig. 6 illustrates the initial placement of the stone capture device and viewing scope of the present invention through the urinary tract into a kidney.

Figs. 7A - 7D illustrate deployment of the sweeping structure on the stone capture device for capturing, fragmenting, and removing a stone within the kidney.

Figs. 8A-8C illustrate the structure and use of an alternative embodiment of the sweeping structure of the present invention.

DETAILED DESCRIPTION OF THE INVENTION

[0023] Referring to Fig. 1, a stone capture device 10 constructed in accordance with the principles of the present invention comprises a sheath 12 having a proximal end 14 and a distal end 16. A deployable sweeping structure 18 is disposed at the distal end of the sheath

12 and is shiftable between a low profile tubular configuration (shown in full line) and an open or deployed concave configuration (shown in broken line). A hub 20 is typically provided at the proximal end 14 of the sheath 12.

[0024] The stone capture device 10 of the present invention is intended to be mounted over the steerable shaft 24 of a conventional viewing scope (26, Fig. 2), typically a ureteroscope, such as those commercially available from Olympus/ACMI. The viewing scope 26 further comprises a control handle 28 attached to a proximal end of the shaft 24. The control handle 28 includes a steering lever 30 which can be advanced and retracted to selectively deflect or "steer" a distal region 32 of the shaft 24, as shown in broken line. The control handle 28 will further include a connector for compiling a light source and an optical element of the viewing scope to a suitable screen and power source (not shown).

[0025] As shown in Fig. 3, a distal tip 40 of the steerable shaft 24 of the viewing scope 26 is introduced through the entire length of the sheath 12 of the stone capture device 10 so that said distal end is received in and attached to a distal tip 42 of the deployable sweeping structure. The deployable sweeping structure 18 is typically a woven or braided mesh, typically formed from polymeric or wire filaments or fibers, so that axial compression of the sweeping structure 18 from its tubular configuration (illustrated in Fig. 3) to a foreshortened configuration (as shown in Figs. 4A and 5A, will cause the sweeping structure to assume a concave configuration, more particularly a conical configuration. Usually, the sweeping structure will be fabricated so that it preferentially bends and everts about a weakened region 44, as shown in Figs. 4A and 5A. Thus, a distal most portion 46 of the sweeping structure 18 will preferentially evert into a proximal most portion 48. Thus, as the steerable shaft 24 is progressively pulled proximally, as shown by the arrows in Figs. 4A and 5A, the steering structure progressively shortens with the forward diameter or width becoming larger.

[0026] The sweeping structure in its tubular configuration, as shown in Fig. 3, has only a single wall and is thus relatively flexible, typically having a bending stiffness in the ranges set forth above. As the sweeping structure 18 is everted, however, the wall becomes doubled, increasing the bending stiffness within the ranges set forth above. The relatively flexible tubular configuration is desirable since it will be over the steerable distal region 32 of the viewing scope. Thus, the viewing scope may be steered even while the sweeping structure 18 is over it. When the sweeping structure is deployed, however, it will have more stiffness and rigidity to facilitate engaging and manipulating the urinary stones within the kidney or bladder. As the deployed sweeping structure is distal to the distal end of the steerable shaft 24, however, the structure will not interfere with steering and advancement.

[0027] The sweeping structure mesh is preferably constructed from a wire braid. Usually eight to 36 wires are used to construct braid. The wire will usually be formed

from a flexible metal or polymer material such as a superelastic nickel-titanium alloy (nitinol), a nylon, or a polyethylene terephthalate (PET).

[0028] The sweeping structure 18 will further include a mechanism for drawing the open end closed after it has been partially or fully deployed. In the exemplary embodiments of Figs. 3, 4A-B, and 5A-B, the structure to close the end is a simple filament or suture 60 which passes through the mid-section of the sweeping structure which becomes the forward edge of the sweeping structure after deployment. Thus, by pulling on the filament, the filament acts as a purse string to draw the sweeping structure closed, as illustrated in Fig. 7D discussed below.

[0029] The viewing scope 26 will be introduced into the urinary tract UT with a stone capture device 10 disposed thereover, as illustrated in Fig. 6. The assembly of the viewing scope 26 and the stone capture device 10 is introduced in the same manner as a conventional ureteroscope without the stone capture device. That is, a distal end of the assembly of the present invention will be introduced through the urethra URTH into the bladder B, and optionally further through the ureter URE and into the kidney K. Once in the kidney, the non-deployed sweeping structure 18 and the distal region 32 of the viewing scope may be steered together using the lever 30 of the viewing scope which selectively deflects a distal portion of the shaft 24 of the viewing scope 26.

[0030] As illustrated in Fig. 7A, the kidney K may have a number of kidney stones KS therein. The sweeping structure 18 and distal region 32 may be steered while the physician views through the optical element 70 of the viewing scope (illustrated in Figs. 4B and 5B). While viewing, illumination will be provided by a light source 72 on the viewing scope. Once a target kidney stone KS is located, as shown in Fig. 7A, the sweeping structure 18 may be deployed, as shown in Fig. 7B. The combination stone capture device 10 and viewing scope 26 (Fig. 2) may then be advanced, while continuing to optically view the region, until the deployed sweeping structure 18 engages a wall of the kidney, as shown in Fig. 7C, to capture the kidney stone between the sweeping structure and the wall. An optical (laser) fiber 80 or other stone fragmentation device may then be introduced through the working channel 74 (Figs. 4B and 5B) of the viewing scope and advanced into the region where the stone is captured. By applying laser or other energy to the stone, the stone will be fragmented. Preferably, irrigation medium will be introduced simultaneously through the working channel to sweep the resulting stone fragments into the double-walled mesh of the deployed sweeping structure, thus simultaneously clearing the scope's field of view and entrapping the stone fragments therein. Occasionally, stones in the kidney are trapped within one of the cul-de-sac-like calices of the kidney. The sweeping structure may be advantageously deployed over the mouth of such a calyx to contain the stone and fragments produced by the lithotripsy process, in exactly the same manner as

above. After the stone has been fragmented sufficiently, and the stone fragments captured, the filaments 60 may be retracted in order to close the sweeping structure 18 over the stone fragments, as shown in Fig. 7D. At that point, the combined assembly of the stone capture device 10 and the viewing scope 26 may be withdrawn from the urinary tract. After the procedure is complete, the stone capture device 10 may be removed from the viewing scope 26, and the stone capture device will usually be disposed of in a conventional manner. The viewing scope, however, can be sterilized and reused in subsequent procedures.

[0031] Referring now to Figs. 8A - 8C, an alternative perforate sweeping structure 100 comprises a carrier sleeve 102 attached at the distal end of a hypotube or other elongate tubular member 104. A pusher rod 106 extends coaxially through an inner passage or lumen of the hypotube 104 and is attached to a perforate sweeping structure 108 which is in a proximally retracted, radially collapsed configuration as shown in Fig. 8A. By pushing on the rod 106, typically using handle 110 while holding on to a second handle 112 which is attached at the proximal end of the hypotube 104, the self-expanding perforate sweeping structure 108 can be distally advanced so that it is released from the sleeve 102 and expands into an open conical configuration, as shown in Fig. 8B. A proximal end 112 of the perforate sweeping structure 108 will also expand to open and align with a passage or lumen 114 (Fig. 8A) which runs through the carrier sleeve 102.

[0032] The sweeping structure assembly 100 may then advance over a viewing scope 120 (Fig. 8B) by advancing a proximal end of the scope into the passage 114 of the sleeve 102. The hypotube 104 may be used to distally advance the sleeve 102 over the viewing structure 120 until the sleeve 102 approaches a distal end 122 of the viewing scope 120, as best seen in Fig. 8B. At that point, the viewing scope 120 and/or the assembly of sleeve 102 and hypotube 104 may be manipulated to cause the deployed perforate sweeping structure 108 to capture kidney stones KS therein. By then engaging a distal periphery 124 of the perforate sweeping structure 108 against the wall W, of the body cavity, kidney stones KS may be captured and energy applied through an optical fiber advanced through a working channel of the viewing scope 120 in order to disrupt the stones. After the stones are disrupted into a plurality of small fragments, the hypotube 104 may be retracted proximally in order to draw and collapse the sweeping structure 108 back into the passage 114 of sleeve 102 (as shown in Fig. 8C), optionally after the viewing scope 120 has been at least partially retracted therein. The viewing scope and sweeping structure assembly 100 may then be withdrawn from the body cavity to remove the stones.

[0033] While the above is a complete description of the preferred embodiments of the invention, various alternatives, modifications, and equivalents may be used. Therefore, the above description should not be taken as

limiting the scope of the invention which is defined by the appended claims.

Claims

1. A stone capture device (10) adapted for use with a steerable viewing scope (26), said device comprising:

a sheath (12) having a distal end (16), a proximal end (14), and a lumen positionable over a shaft (24) of the viewing scope (26); and a perforate sweeping structure (18) extending distally from the distal end of the sheath (12), wherein the perforate sweeping structure (18) is shiftable between a tubular configuration with a width about the same as that of the sheath (12) and a concave configuration which increases in width in the distal direction, wherein the sweeping structure (18) has a distal end (42) arranged to receive and attach to a distal end of the steerable viewing scope (26) when the steerable viewing scope (26) is disposed within the perforate sweeping structure (18) and wherein the sweeping structure (18) is sufficiently flexible and bendable to allow steering of the steerable viewing scope (26) within the sweeping structure prior to deployment to the concave configuration.

2. A device as in claim 1, further comprising:

means (60) for closing a distal end of the deployed concave sweeping structure (18) to capture stone fragments therein.

3. A device as in claim 2, wherein the means for closing a distal end of the deployed concave structure comprises a tether (60) extending around the distal end of the deployed concave sweeping structure, wherein the tether (60) can be drawn to close the distal end.

4. A device as in claim 3, wherein the sweeping structure (18) comprises woven or braided filaments arranged as a mesh tube which can be foreshortened to evert into a double-walled concave structure.

5. A device as in claim 4, wherein the double-walled concave structure has a generally conical or hemispherical geometry.

6. A device as in any one of the preceding claims, wherein the sheath (12) is configured to position the perforate sweeping structure (18) distally over a distal region of the viewing scope (26) while the sweeping structure (18) is in the tubular configuration and to position the sweeping structure (18) distally of the

viewing scope (26) while the sweeping structure (18) is in its concave configuration.

7. A device as in claim 6, wherein the sweeping structure (18) in its concave configuration is sufficiently stiff to engage stones within a body cavity and urge said stones against a cavity wall.

8. A device as in any one of the preceding claims, wherein the sweeping structure (18) in its concave configuration has a width which is at least twice that of the sheath (12), preferably being from twice to eight fold larger than the sheath width.

9. A device as in any one of the preceding claims, wherein the sheath (12) has a length less than that of the shaft (24) of the associated viewing scope (26).

10. A device as in one of the preceding claims, wherein a distal end (42) of the perforate sweeping structure (18) is removably connectable to a distal end of the steerable viewing scope (26), wherein a proximal end of the structure can be distally advanced by the sheath (12) to shift the sweeping structure (18) from its tubular configuration to its conical configuration.

11. A device as in one of the preceding claims, further comprising a package wherein the device is maintained in the sterile package.

12. A system for fragmenting and capturing a stone in a body cavity, said system comprising:

a steerable viewing scope (26) adapted for transureteral introduction to the kidney, said scope having a shaft (24) with an optical viewing element at its distal end and a working channel (74); and

a device (10) as in one of the preceding claims, wherein the device (10) is receivable over the shaft (24) of the steerable viewing scope (26).

13. A system as in claim 12, further comprising an optical wave guide (80) advanceable through the working channel (74) and capable of delivering laser energy to ablate a stone captured by the sweeping structure (18) of the stone capture device (10).

14. A system as in claim 13, further comprises a mechanical tool advanceable through the working channel (74) and capable of mechanically disrupting a stone captured by the sweeping structure (18) of the stone capture device (10).

Patentansprüche

1. Steinerfassungsvorrichtung (10) zur Verwendung

mit einem lenkbaren Sichtgerät (26), wobei die genannte Vorrichtung Folgendes umfasst:

einen Mantel (12) mit einem distalen Ende (16), einem proximalen Ende (14) und einem Lumen, das über einer Welle (24) des Sichtgeräts (26) positioniert werden kann; und
 eine perforierte Abtaststruktur (18), die sich distal vom distalen Ende des Mantels (12) erstreckt, wobei die perforierte Abtaststruktur (18) zwischen einer tubulären Konfiguration mit einer Breite, die etwa gleich der des Mantels (12) ist, und einer konkaven Konfiguration verstellt werden kann, deren Breite in distaler Richtung zunimmt, wobei die Abtaststruktur (18) ein distales Ende (42) zum Aufnehmen und Befestigen an einem distalen Ende des lenkbaren Sichtgeräts (26) hat, wenn das lenkbare Sichtgerät (26) in der perforierten Abtaststruktur (18) angeordnet ist, und wobei die Abtaststruktur (18) flexibel und biegsam genug ist, um ein Lenken des lenkbaren Sichtgeräts (26) in der Abtaststruktur vor dem Ausweiten in die konkave Konfiguration zuzulassen.

2. Vorrichtung nach Anspruch 1, die ferner Folgendes umfasst:

Mittel (60) zum Schließen eines distalen Endes der ausgeweiteten konkaven Abtaststruktur (18), um Steinfragmente darin einzufangen.

3. Vorrichtung nach Anspruch 2, wobei das Mittel zum Schließen eines distalen Endes der ausgeweiteten konkaven Struktur eine Halteleine (60) umfasst, die um das distale Ende der ausgeweiteten konkaven Abtaststruktur verläuft, wobei an der Halteleine (60) gezogen werden kann, um das distale Ende zu schließen.
4. Vorrichtung nach Anspruch 3, wobei die Abtaststruktur (18) gewebte oder geflochtene Filamente umfasst, die zu einer Gitternetzröhre angeordnet sind, die verkürzt werden kann, um sie in eine doppelwandige konkave Struktur zu evertieren.
5. Vorrichtung nach Anspruch 4, wobei die doppelwandige konkave Struktur eine allgemein konische oder hemisphärische Geometrie hat.
6. Vorrichtung nach einem der vorherigen Ansprüche, wobei der Mantel (12) zum Positionieren der perforierten Abtaststruktur (18) distal über einer distalen Region des Sichtgeräts (26) konfiguriert ist, während die Abtaststruktur (18) in der tubulären Konfiguration ist, um die Abtaststruktur (18) distal zu dem Sichtgerät (26) zu positionieren, während die Abtaststruktur (18) in ihrer konkaven Konfiguration ist.

7. Vorrichtung nach Anspruch 6, wobei die Abtaststruktur (18) in ihrer konkaven Konfiguration steif genug ist, um an Steinen in einem Körperhohlraum anzugreifen und die genannten Steine gegen eine Hohlraumwand zu drücken.

8. Vorrichtung nach einem der vorherigen Ansprüche, wobei die Breite der Abtaststruktur (18) in ihrer konkaven Konfiguration wenigstens zweimal, vorzugsweise zwei bis acht Mal so groß ist wie die Breite des Mantels (12).

9. Vorrichtung nach einem der vorherigen Ansprüche, wobei der Mantel (12) eine Länge hat, die geringer ist als die der Welle (24) des assoziierten Sichtgeräts (26).

10. Vorrichtung nach einem der vorherigen Ansprüche, wobei ein distales Ende (42) der perforierten Abtaststruktur (18) entferntbar mit einem distalen Ende des lenkbaren Sichtgeräts (26) verbunden werden kann, wobei ein proximales Ende der Struktur von dem Mantel (12) distal vorgeschoben werden kann, um die Abtaststruktur (18) von ihrer tubulären Konfiguration in ihre konische Konfiguration zu verstellen.

11. Vorrichtung nach einem der vorherigen Ansprüche, die ferner eine Packung umfasst, wobei die Vorrichtung in der sterilen Packung gehalten wird.

12. System zum Fragmentieren und Erfassen eines Steins in einem Körperhohlraum, wobei das genannte System Folgendes umfasst:

ein lenkbare Sichtgerät (26) zum transurethralen Einführen in die Niere, wobei das genannte Gerät eine Welle (24) mit einem optischen Sichtelement am distalen Ende und einem Arbeitskanal (74) hat; und
 eine Vorrichtung (10) nach einem der vorherigen Ansprüche, wobei die Vorrichtung (10) über die Welle (24) des lenkbaren Sichtgeräts (26) aufgenommen werden kann.

13. System nach Anspruch 12, das ferner einen optischen Wellenleiter (80) umfasst, der durch den Arbeitskanal (74) vorgeschoben werden kann und Laserenergie zum Abladieren eines Steins zuführen kann, der von der Abtastvorrichtung (18) der Steinerfassungsvorrichtung (10) erfasst wird.

14. System nach Anspruch 13, das ferner ein mechanisches Werkzeug umfasst, das durch den Arbeitskanal (74) vorgeschoben werden und einen von der Abtastvorrichtung (18) der Steinerfassungsvorrichtung (10) erfassten Stein mechanisch zerschlagen kann.

Revendications

1. Dispositif de capture de calculs (10) adapté à des fins d'utilisation avec un instrument d'examen visuel orientable (26), ledit dispositif comportant :
 - une gaine (12) ayant une extrémité distale (16), une extrémité proximale (14), et une lumière positionnable sur une tige (24) de l'instrument d'examen visuel (26) ; et
 - une structure de balayage perforée (18) s'étendant dans le sens distal depuis l'extrémité distale de la gaine (12), dans lequel la structure de balayage perforée (18) est en mesure de changer entre une configuration tubulaire avec une largeur approximativement identique à celle de la gaine (12) et une configuration concave qui augmente en largeur dans le sens distal, dans lequel la structure de balayage (18) a une extrémité distale (42) agencée à des fins de réception et de fixation sur une extrémité distale de l'instrument d'examen visuel orientable (26) quand l'instrument d'examen visuel orientable (26) est disposé à l'intérieur de la structure de balayage perforée (18) et dans lequel la structure de balayage (18) est suffisamment flexible et pliable pour permettre l'orientation de l'instrument d'examen visuel orientable (26) à l'intérieur de la structure de balayage avant le déploiement jusqu'à la configuration concave.
2. Dispositif selon la revendication 1, comportant par ailleurs :
 - un moyen (60) permettant de fermer une extrémité distale de la structure de balayage concave déployée (18) à des fins de capture de fragments de calculs dans celle-ci.
3. Dispositif selon la revendication 2, dans lequel le moyen permettant de fermer une extrémité distale de la structure concave déployée comporte un dispositif d'attache (60) s'étendant autour de l'extrémité distale de la structure de balayage concave déployée, dans lequel le dispositif d'attache (60) peut être resserré pour fermer l'extrémité distale.
4. Dispositif selon la revendication 3, dans lequel la structure de balayage (18) comporte des filaments tissés ou tressés agencés sous la forme d'un tube en mailles qui peut être raccourci pour se retourner en une structure concave à double paroi.
5. Dispositif selon la revendication 4, dans lequel la structure concave à double paroi a une géométrie généralement conique ou hémisphérique.
6. Dispositif selon l'une quelconque des revendications précédentes, dans lequel la gaine (12) est configurée pour positionner la structure de balayage perforée (18) de manière distale sur une région distale de l'instrument d'examen visuel (26) quand la structure de balayage (18) est dans la configuration tubulaire et pour positionner la structure de balayage (18) de manière distale par rapport à l'instrument d'examen visuel (26) quand la structure de balayage (18) est dans sa configuration concave.
7. Dispositif selon la revendication 6, dans lequel la structure de balayage (18) dans sa configuration concave est suffisamment rigide pour entrer en prise avec des calculs à l'intérieur d'une cavité corporelle et solliciter lesdits calculs contre une paroi de la cavité.
8. Dispositif selon l'une quelconque des revendications précédentes, dans lequel la structure de balayage (18) dans sa configuration concave a une largeur qui fait au moins deux fois celle de la gaine (12), étant de préférence de deux fois à huit fois plus large par rapport à la largeur de la gaine.
9. Dispositif selon l'une quelconque des revendications précédentes, dans lequel la gaine (12) a une longueur inférieure à celle de la tige (24) de l'instrument d'examen visuel associé (26).
10. Dispositif selon l'une quelconque des revendications précédentes, dans lequel une extrémité distale (42) de la structure de balayage perforée (18) est en mesure d'être raccordée de manière amovible au niveau d'une extrémité distale de l'instrument d'examen visuel orientable (26), dans lequel une extrémité proximale de la structure peut être avancée de manière distale par la gaine (12) pour faire passer la structure de balayage (18) de sa configuration tubulaire à sa configuration conique.
11. Dispositif selon l'une quelconque des revendications précédentes, comportant par ailleurs un emballage dans lequel le dispositif est maintenu dans l'emballage stérile.
12. Système permettant de fragmenter et de capturer un calcul dans une cavité corporelle, ledit système comportant :
 - un instrument d'examen visuel orientable (26) adapté à des fins d'introduction transurétrale au niveau du rein, ledit instrument d'examen ayant une tige (24) munie d'un élément visuel optique au niveau de son extrémité distale et un canal opérateur (74) ; et
 - un dispositif (10) selon l'une quelconque des revendications précédentes, dans lequel le dispositif (10) est en mesure d'être reçu sur la tige

(24) de l'instrument d'examen visuel orientable (26).

13. Système selon la revendication 12, comportant par ailleurs un guide d'ondes optiques (80) en mesure d'avancer au travers du canal opérateur (74) et capable d'acheminer de l'énergie laser à des fins d'ablation d'un calcul capturé par la structure de balayage (18) du dispositif de capture de calculs (10). 5
10
14. Système selon la revendication 13, comportant par ailleurs un outil mécanique en mesure d'avancer au travers du canal opérateur (74) et capable de détruire mécaniquement un calcul capturé par la structure de balayage (18) du dispositif de capture de calculs (10). 15
20
25
30
35
40
45
50
55

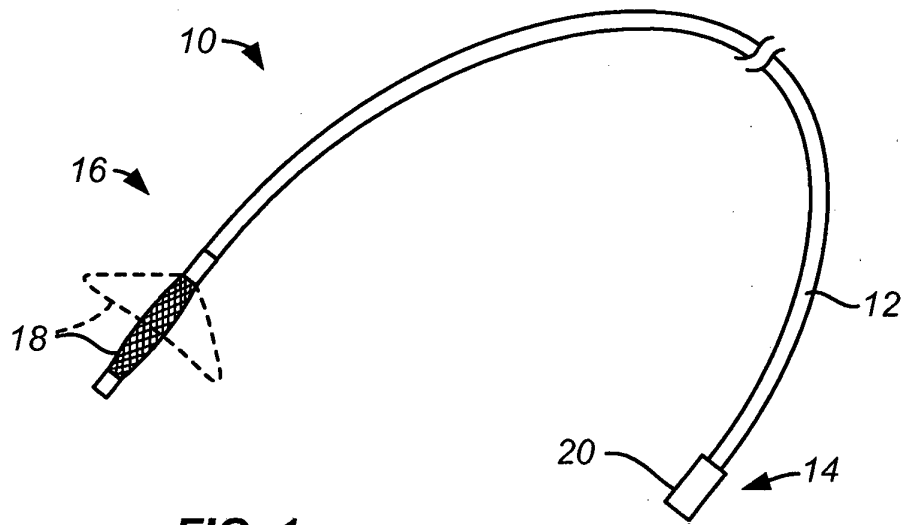

FIG. 1

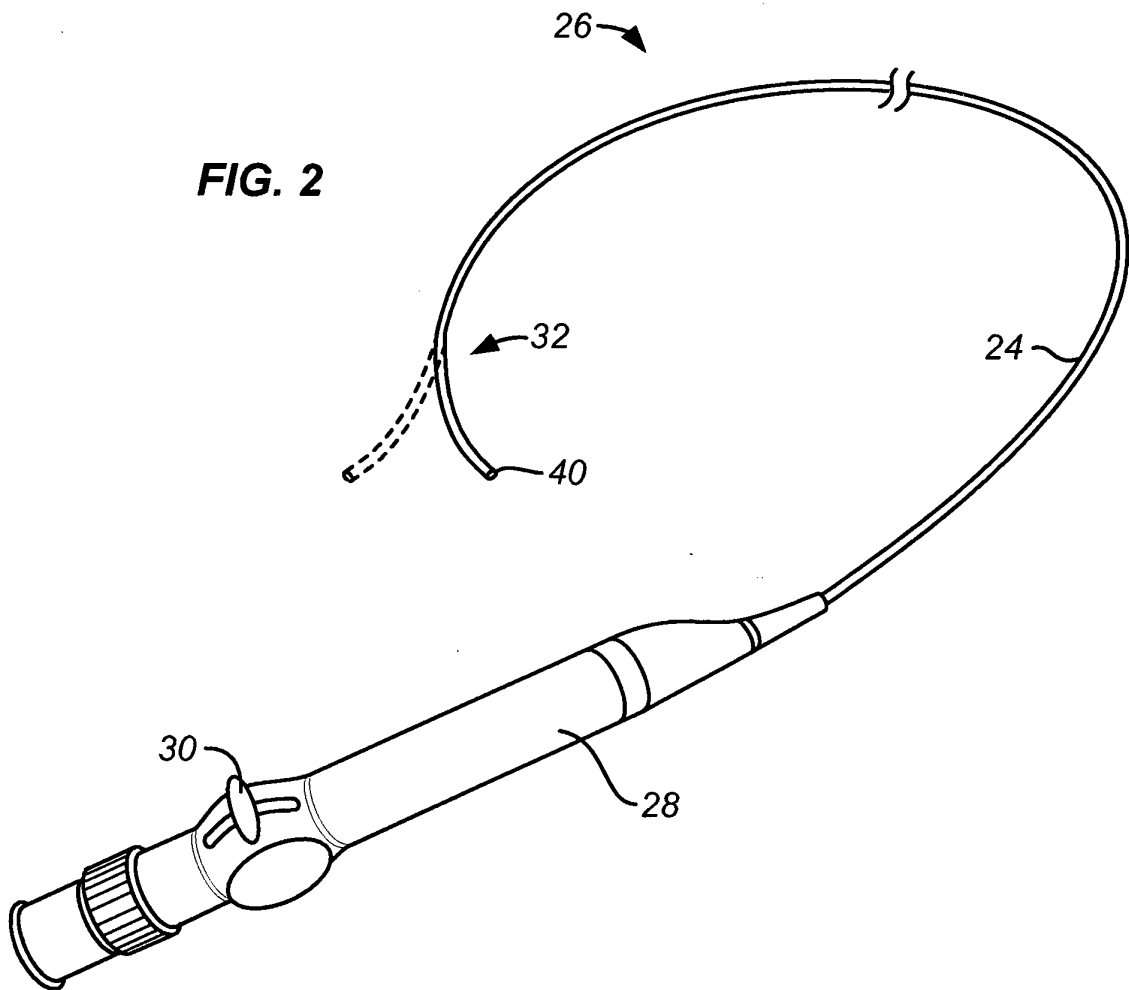

FIG. 2

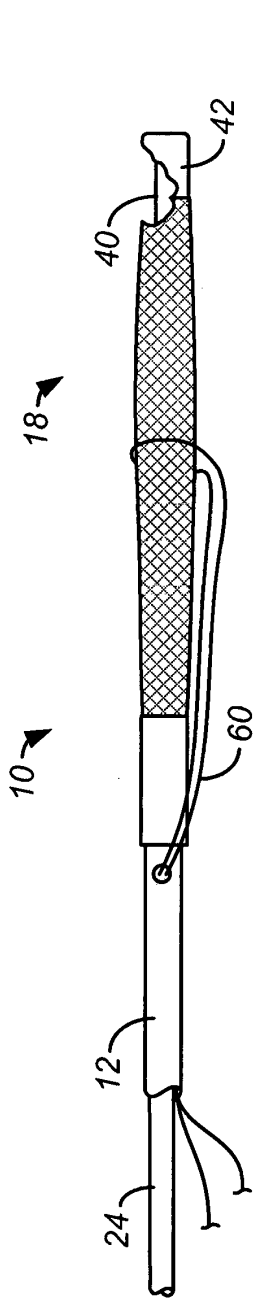

FIG. 3

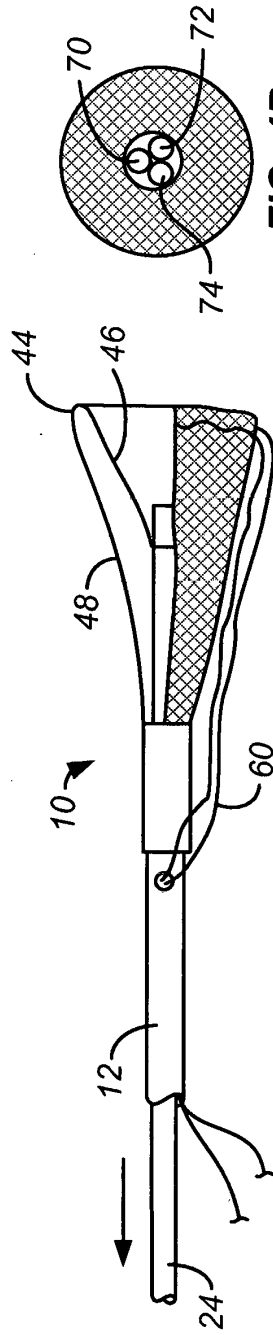

FIG. 4A

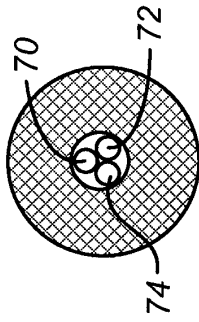

FIG. 4B

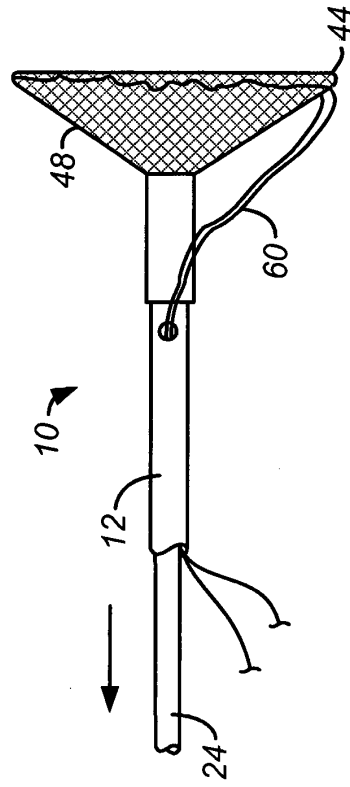

FIG. 5A

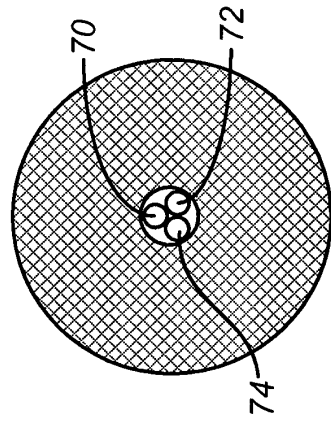

FIG. 5B

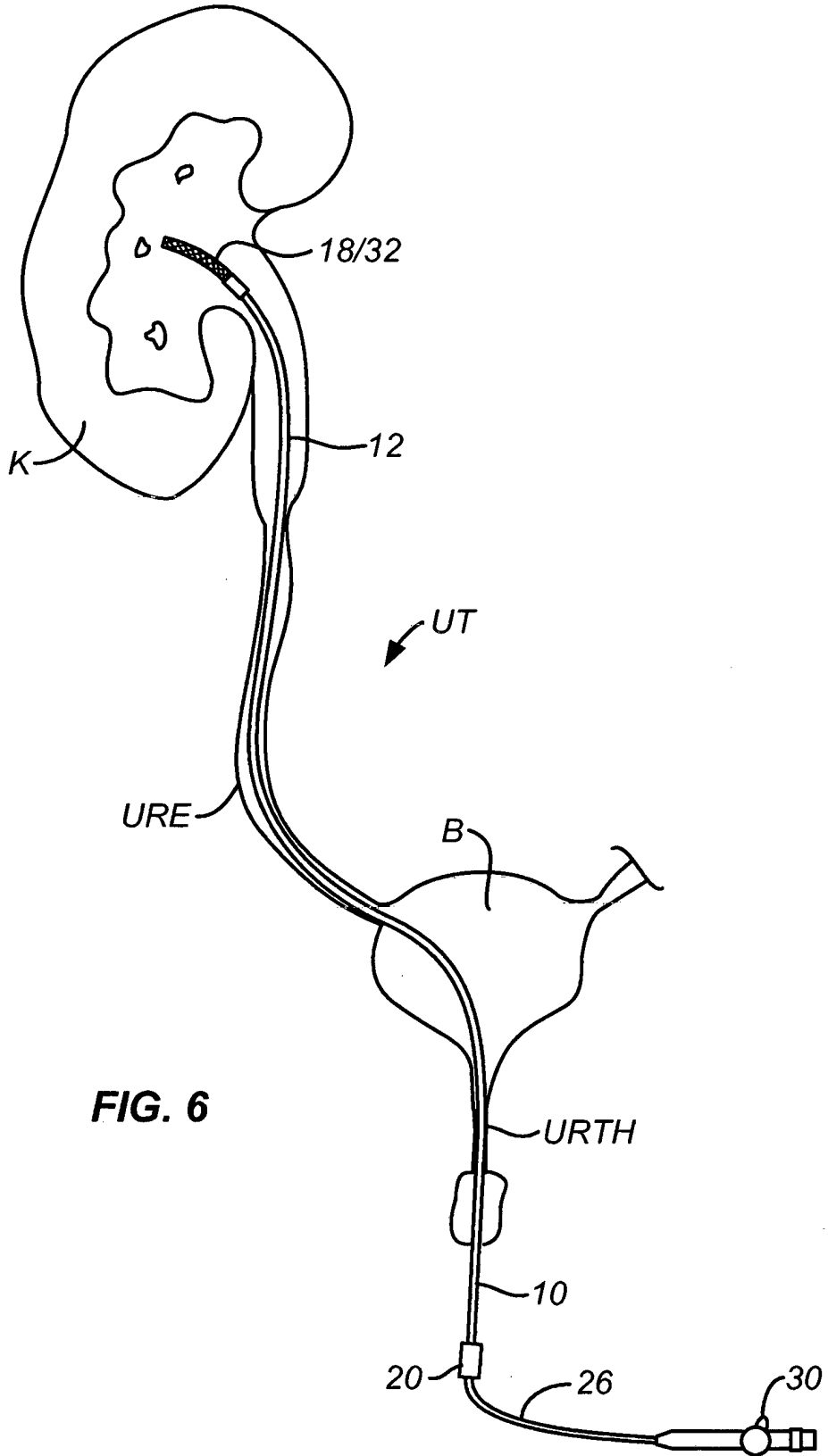

FIG. 6

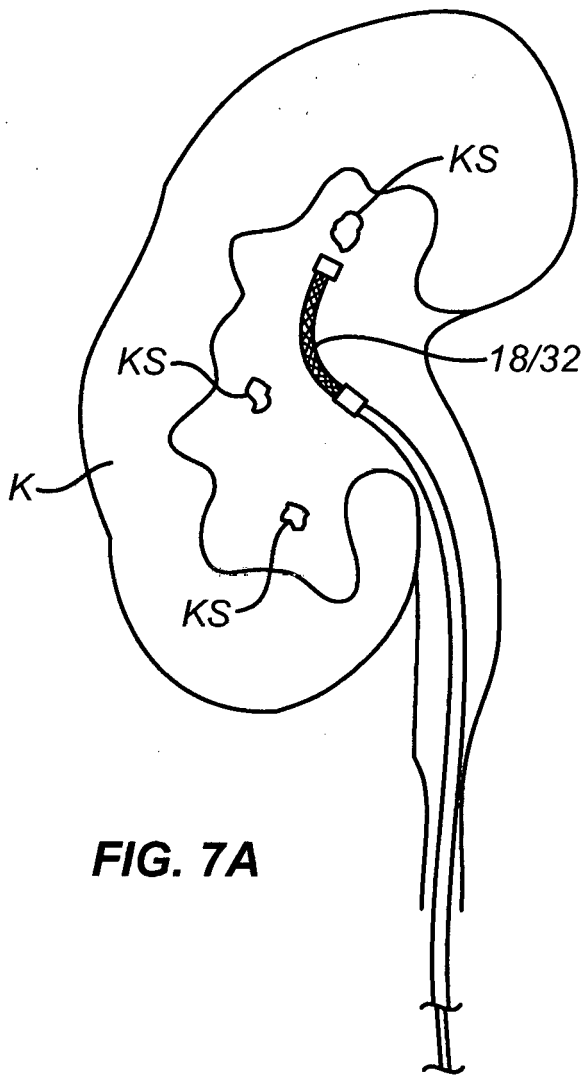

FIG. 7A

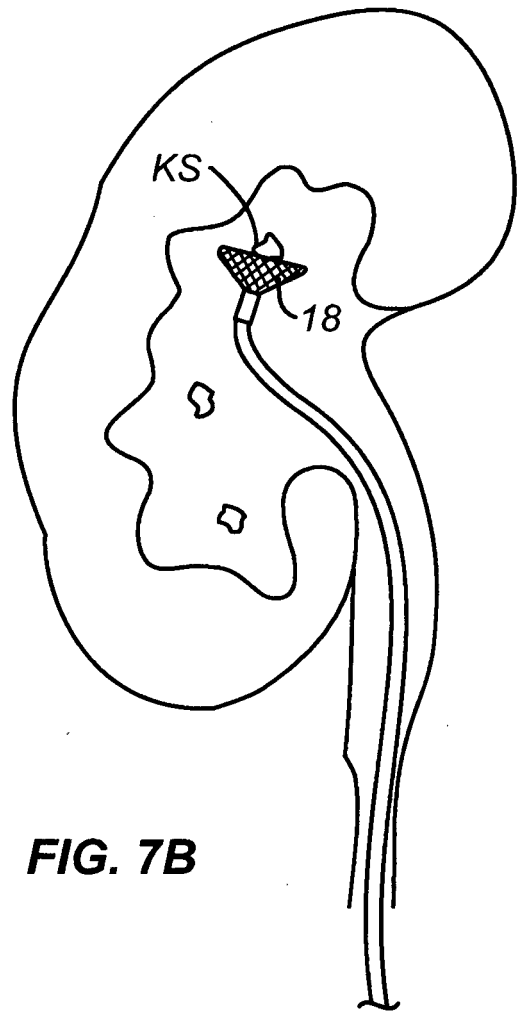
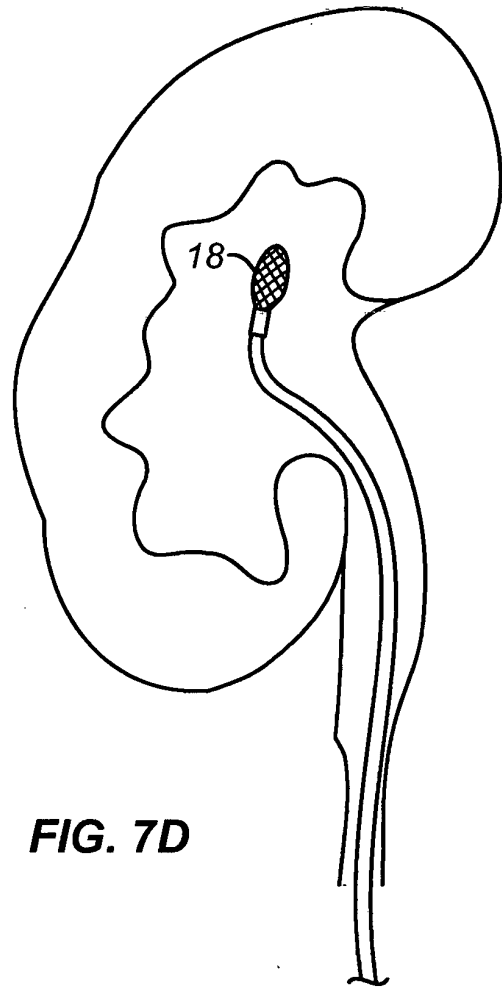
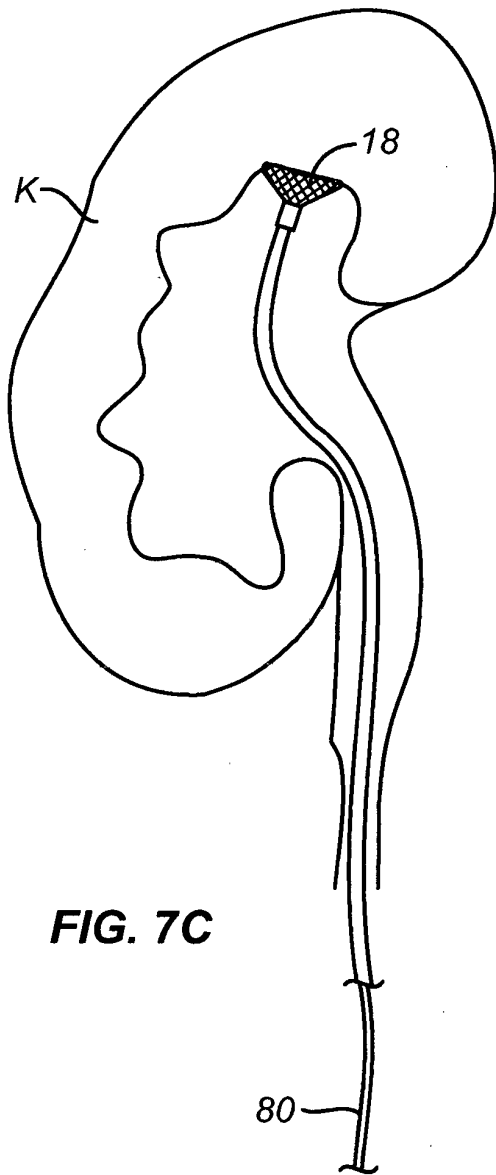

FIG. 7B



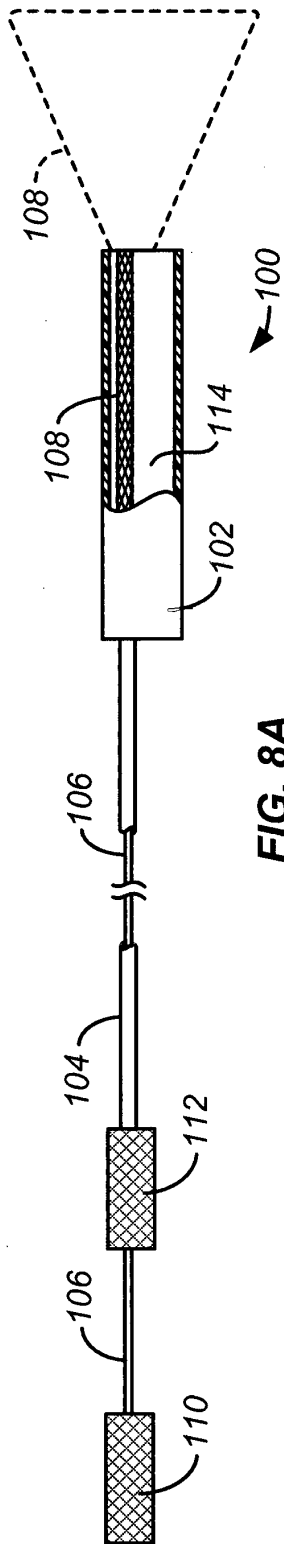

FIG. 8A

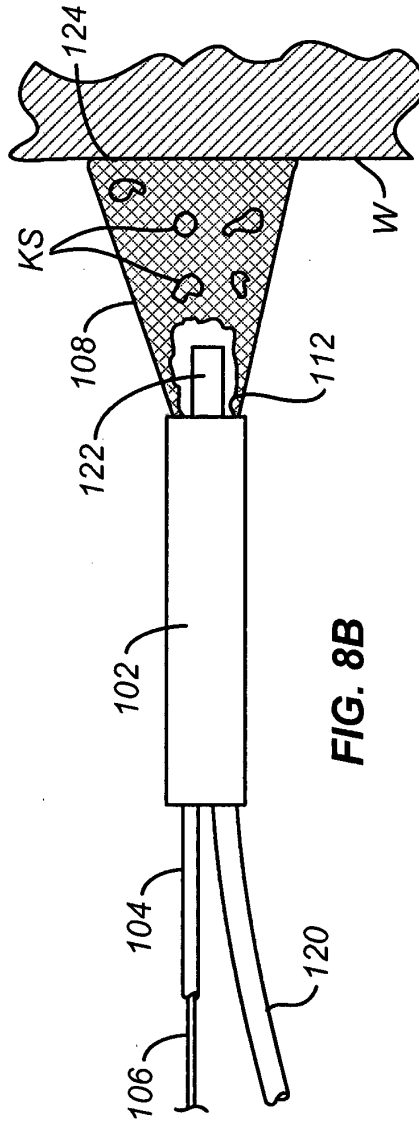

FIG. 8B

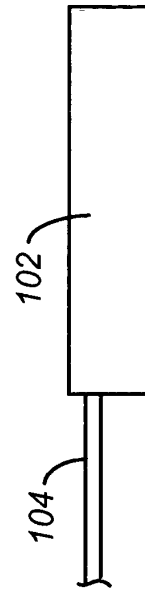

FIG. 8C

REFERENCES CITED IN THE DESCRIPTION

This list of references cited by the applicant is for the reader's convenience only. It does not form part of the European patent document. Even though great care has been taken in compiling the references, errors or omissions cannot be excluded and the EPO disclaims all liability in this regard.

Patent documents cited in the description

- US 3760810 A [0005]
- US 3870048 A [0005]
- US 4222308 A [0005]
- US 4257420 A [0005]
- US 4471766 A [0005]
- US 4735194 A [0005]
- US 5423834 A [0005]
- US 5507797 A [0005]
- US 6099535 A [0005]
- US 6645195 A [0005]
- US 6869395 A [0005]
- US 7204804 A [0005]
- US 7223230 A [0005]
- US 20060116693 A [0005]
- US 6264664 B [0006]
- US 5716321 A [0007]
- US 6443159 B [0008]
- US 20050049619 A [0009]
- WO 2005079678 A [0010]

专利名称(译)	用于从体腔中捕获和去除尿石的系统		
公开(公告)号	EP2355717B1	公开(公告)日	2014-02-19
申请号	EP2009830998	申请日	2009-12-01
[标]申请(专利权)人(译)	经皮SYST		
申请(专利权)人(译)	经皮系统公司.		
当前申请(专利权)人(译)	经皮系统公司.		
[标]发明人	DESAI RUPESH YEE STEVEN BEHL ROBERT S		
发明人	DESAI, RUPESH YEE, STEVEN BEHL, ROBERT S.		
IPC分类号	A61B17/22 A61B17/221		
CPC分类号	A61B17/221 A61B1/00085 A61B1/018 A61B1/307 A61B17/2202 A61B18/24 A61B18/26 A61B2017/22014 A61B2017/22035 A61B2017/22072 A61B2017/2215 A61B2090/3614 A61B2217/007		
优先权	61/170055 2009-04-16 US 61/118802 2008-12-01 US		
其他公开文献	EP2355717A1 EP2355717A4		
外部链接	Espacenet		

摘要(译)

石头捕获装置包括轴，该轴在其远端具有可展开的清扫结构。该轴适于可拆卸地放置传统输尿管镜上并与之连接。石头捕获装置和输尿管镜的组合可以被引入泌尿道以捕获，破碎和去除膀胱和肾脏中的结石。

