



(11) **EP 1 707 235 B1**

(12) **EUROPEAN PATENT SPECIFICATION**

(45) Date of publication and mention of the grant of the patent:  
**07.01.2009 Bulletin 2009/02**

(51) Int Cl.:  
**A61M 39/06<sup>(2006.01)</sup> A61B 17/34<sup>(2006.01)</sup>**

(21) Application number: **06005181.0**

(22) Date of filing: **14.03.2006**

(54) **Surgical hand access apparatus**

Chirurgisches Handgerät

Appareil chirurgical pour accès manuel

(84) Designated Contracting States:  
**DE ES FR GB IE IT**

(30) Priority: **31.03.2005 US 95340**

(43) Date of publication of application:  
**04.10.2006 Bulletin 2006/40**

(73) Proprietor: **Tyco Healthcare Group LP**  
**Norwalk, Connecticut 06856 (US)**

(72) Inventors:

- **Jensen, David**  
**Westbrook, CT 06498 (US)**

• **Wenchell, Thomas**  
**Durham, CT 06422 (US)**

(74) Representative: **HOFFMANN EITLE**  
**Patent- und Rechtsanwälte**  
**Arabellastrasse 4**  
**81925 München (DE)**

(56) References cited:

**FR-A- 2 710 270** **US-A- 5 411 483**  
**US-A- 6 033 426** **US-A- 6 086 570**  
**US-B1- 6 610 031**

**EP 1 707 235 B1**

Note: Within nine months of the publication of the mention of the grant of the European patent in the European Patent Bulletin, any person may give notice to the European Patent Office of opposition to that patent, in accordance with the Implementing Regulations. Notice of opposition shall not be deemed to have been filed until the opposition fee has been paid. (Art. 99(1) European Patent Convention).

## Description

### BACKGROUND

#### 1. Field of the Disclosure

[0001] The present disclosure relates generally to surgical devices for facilitating sealed access across a body wall and into a body cavity and, more particularly, to a surgical access apparatus adaptable to form a seal about either the surgeon's hand and/or surgical instruments during laparoscopic and endoscopic surgical procedures.

#### 2. Description of the Related Art

[0002] Minimally invasive surgical procedures including both endoscopic and laparoscopic procedures permit surgery to be performed on organs, tissues and vessels far removed from an opening within the tissue. Laparoscopic and endoscopic procedures generally require that any instrumentation inserted into the body be sealed, i.e. provisions must be made to ensure that gases do not enter or exit the body through the incision as, e.g., in surgical procedures in which the surgical region is insufflated. These procedures typically employ surgical instruments which are introduced into the body through a cannula. The cannula has a seal assembly associated therewith. The seal assembly provides a substantially fluid tight seal about the instrument to preserve the integrity of the established pneumoperitoneum.

[0003] Minimally invasive procedures have several advantages over traditional open surgery, including less patient trauma, reduced recovery time, reduced potential for infection, etc... However, despite its recent success and overall acceptance as a preferred surgical technique, minimally invasive surgery, such as laparoscopy, has several disadvantages. In particular, surgery of this type requires a great deal of surgeon skill in order for the surgeon to manipulate the long narrow endoscopic instruments about a remote site under endoscopic visualization. In addition, in laparoscopic surgery involving the intestinal tract, it is often preferable to manipulate large sections of the intestines to perform the desired procedure. These manipulations are not practical with current laparoscopic tools and procedures accessing the abdominal cavity through a trocar or cannula.

[0004] To address these concerns, recent efforts have focused on hand-assisted laparoscopic techniques and procedures. These procedures incorporate both laparoscopic and conventional surgical methodologies. The hand assisted technique is performed in conjunction with a hand access seal which is an enlarged device positionable within the incision in, e.g., the insufflated abdominal cavity. The device includes a seal for forming a seal about the surgeon's arm upon insertion while permitting surgical manipulation of the arm within the cavity. However, known hand access seals are quite cumbersome and

incorporate elaborate sealing mechanisms. Moreover, these hand access seals are ill-adapted to accommodate radial manipulation of the surgeon's arm within the seal.

[0005] D1 (U.S. Patent No. 6,086,570 to Aboul-Hosn et al.) discloses a self-sealing hemostasis valve having a first membrane 20 with an opening 22 offset from the center and a second membrane 30 with an opening 34 offset from the center in a direction opposite of the offset in the first membrane 20.

[0006] D2 (U.S. Patent No. 5,411,483 to Loomas et al.) discloses a gas-tight seal 10 for a trocar tube 14. The seal 10 includes three main components: a seal body 30 which attaches to the rear housing 14 of a trocar tube 14, an instrument seal 32 and a seal mounting for the instrument seal 32. The seal mounting 34 includes a stabilizing ring 44, a stabilizing ring anchor 50 and a corrugated zone 52. The stabilizing ring 44 interconnects the instrument seal 32 and the corrugated zone 52, and transmits any radial force applied to the instrument seal 32 uniformly to the corrugated zone 52.

[0007] D3 (U.S. Patent No. 6,033,426 to Kaji) discloses an access device having a first valve 1 located on a side outside the body, and a second valve 2 located on the side inside of the abdominal cavity. The first valve 1 and the second valve 2 are connected to each other with a thin-film-like sleeve (communication body) 3 which is formed of, for example, a thin and expandable latex rubber.

#### 30 SUMMARY

[0008] Accordingly, the present disclosure relates to a surgical access apparatus adaptable to permit the sealed insertion of either the surgeon's hand and/or surgical instruments during laparoscopic and endoscopic surgical procedures. In one preferred embodiment, the surgical access apparatus includes an access member having a passageway therethrough and first and second seal members mounted across the passageway. The first seal member includes an inner seal portion and an outer seal portion. The inner seal portion has an aperture for substantial sealed reception of an object inserted therein and is arranged about a first seal axis. The outer seal portion includes at least one expansible rib dimensioned to facilitate movement of the aperture to a displaced position radially displaced from the first seal axis upon insertion of the object therethrough. The second seal member also has an inner portion defining an aperture for substantial sealed reception of the object and is arranged about a second seal axis radially displaced from the first seal axis. Preferably, the apertures of the first and second seal members are in non-overlapping relation and form a substantial seal within the passageway of the access member in the absence of the object inserted within the aperture of the first member. The first seal member is adapted to move to the displaced position upon insertion of the object therethrough whereby the apertures of the first seal member and the second seal member overlap. The

outer seal portion of the first seal member may include a plurality of expansible ribs. The expansible ribs may be arranged along respective lines of intersection with the first seal axis of the first seal member.

**[0009]** In another preferred embodiment, the surgical access apparatus includes an access member having a passageway therethrough and a seal member mounted across the passageway. The seal member includes an inner seal portion and an outer seal portion. The inner seal portion has an aperture for substantial sealed reception of an object inserted therein and is arranged about a seal axis. The outer seal portion includes at least one expansible rib dimensioned to facilitate movement of the aperture to a displaced position radially displaced from the seal axis upon insertion of the object there-through. The at least one expansible rib is generally arranged along a line of intersection with the seal axis of the seal member. The access member may further include a second seal member mounted adjacent the first seal member. The second seal member has an inner portion defining an aperture for substantial sealed reception of the object and is arranged about a second seal axis radially displaced from the first-mentioned seal axis. The first seal member is preferably adapted to move to the displaced position upon insertion of the object there-through whereby the apertures of the first seal member and the second seal member overlap.

**[0010]** In another preferred embodiment, the surgical hand access apparatus includes a liner base adapted for insertion through an opening within body tissue for at least partial positioning within the body and an access housing mountable to the liner base. The access housing includes a housing member for positioning outside the body and defines a passageway dimensioned for permitting passage of either a surgeon's hand or arm of a surgeon, a first seal member mounted to the housing member and a second seal member mounted within the housing member adjacent the first seal member. The first seal member includes an inner seal portion and an outer seal portion. The inner seal portion has an aperture for substantial sealed reception of either the surgeon's hand or arm. The second seal member also has an inner portion defining an aperture for substantial sealed reception of either the surgeon's hand or arm. The first and second seal members form a substantial seal within the passageway of the housing member in the absence of the hand or arm of the surgeon. However, during insertion of either the surgeon's hand or arm within the aperture of the first seal member, the inner seal portion of the first seal member is adapted to move to position the aperture thereof in at least partial overlapping relation with the aperture of the second seal member to permit passage of the surgeon's hand or arm through the housing member. The outer seal portion of the first seal member includes at least one expansible rib (preferably, a plurality of ribs) dimensioned to facilitate movement of the aperture of the first seal member to a displaced position radially displaced from the first seal axis.

## **BRIEF DESCRIPTION OF THE DRAWINGS**

**[0011]** Preferred embodiments of the present disclosure will be better appreciated by reference to the drawings wherein:

Preferred embodiments of the present disclosure will be better appreciated by reference to the drawings wherein:

FIG. 1 is a perspective of the hand access apparatus in accordance with the principles of the present disclosure illustrating the access housing and liner base;

FIG. 2 is a cross sectional view of the access apparatus in accordance with the embodiment of FIG. 1 taken along lines 2-2 of FIG. 1;

FIG. 3 is a top plan view of a first seal within the access housing;

FIG. 4 is a side plan view of the first seal;

FIG. 5 is a top plan view of a second seal within the access housing;

FIG. 5A is a top plan view of an alternate embodiment of the second seal;

FIG. 6 is a top plan view of the first and second seals with the second seal depicted in phantom; FIGS. 7-8 are views illustrating insertion of the hand access apparatus within an incision; and FIG. 9 is a cross-sectional view similar to the view of FIG. 2 illustrating radial movement of the first seal during insertion of an object within the access housing.

## **DETAILED DESCRIPTION OF THE PREFERRED EMBODIMENTS**

**[0012]** The surgical access apparatus of the present disclosure provides a substantial seal between the body cavity of a patient and the outside atmosphere before, during and after insertion of an object through the apparatus. Moreover, the access apparatus of the present disclosure is adapted for positioning within an incision and may retract the tissue defining the incision to permit access to the underlying tissue. The access apparatus is particularly adapted for accommodating the hand and/or arm of a surgeon during a hand assisted laparoscopic procedure and establishing a gas tight seal with the arm when inserted. However, the access apparatus may be adapted to receive other objects, such as surgical instruments. The access apparatus is further adapted to substantially close in the absence of the object to maintain the integrity of the insufflated peritoneal cavity.

**[0013]** Although the specific focus of this disclosure will be on a preferred laparoscopic procedure, it will be noted that laparoscopic surgery is merely representative of a type of operation wherein a procedure can be performed in a body cavity with access through a body wall.

**[0014]** In the following description, as is traditional the

term "proximal" refers to the portion of the instrument closest to the operator, while the term "distal" refers to the portion of the instrument remote from the operator.

**[0015]** Referring now to FIGS. 1-2, hand access apparatus 10 includes two main components, namely, access housing 12 and liner base 14 which is mounted to the access housing 12. Access housing 12 is positioned external to the body, preferably, in contact with the outer skin of the body and consists of outer frame or housing member 16, seal support 18 disposed within the housing member 16 and first and second seals 20, 22. Housing member 16 preferably defines outer flange 24 dimensioned for engagement by the surgeon and lower U-shaped flange 26. U-shaped flange 26 contacts the skin of the patient upon application of access apparatus 10. U-shaped flange 26 also serves to mount liner base 14. Housing member 16 defines housing axis "a" and internal longitudinal passageway 28 extending through the housing member 16. Housing member 16 may be a single piece component or alternatively incorporate multiple pieces assembled together by conventional means. In one preferred embodiment, housing member 16 incorporates two components 16a, 16b as depicted in FIG. 2. Housing component 16b serves as a cover for enclosing first and second seals 20, 22 and is connected to housing component 16a in fixed relation.

**[0016]** Seal support 18 of access housing 12 is an elongated annular collar which extends at least partially within housing member 16. The upper surface 30 of seal support 18 includes a plurality (two are shown) of upstanding posts 32 peripherally spaced about the periphery of the upper surface 30.

**[0017]** Referring now to FIGS. 3-4, in conjunction with FIGS. 1-2, first seal 20 includes outer seal portion 34 and inner seal portion 36. Outer seal portion 34 defines a plurality of apertures 38 which receive corresponding posts 32 of seal support 18 to mount first seal 20 to the seal support 18. Outer seal portion 34 also includes a plurality of ribs 40 radially displaced about the outer seal portion 34. Ribs 40 define an undulating arrangement as shown in FIG. 4. The undulating arrangement permits expansion of outer seal portion 34 particularly during offset manipulation of the object relative to housing axis "a". Ribs 40 are each preferably arranged along a line of intersection "b" with housing axis "a" to permit uniform expansion and movement of first seal 20. Ribs 40 may take other shapes and forms such as, for example, a sinusoidal configuration, pyramidal, convex, concave etc...

**[0018]** Inner seal portion 36 defines internal aperture or opening 42. Aperture 42 is arranged about first seal axis "c" (FIG. 2) which is preferably radially offset from housing axis "a". Aperture 42 may be any suitable geometrical shape including circular, elliptical, square, rectangular, or any other polygonal arrangement. In the preferred embodiment, aperture 42 is generally D-shaped. Inner seal portion 36 is adapted to radially move upon insertion of an object through aperture 42 as facilitated by ribs 40 to permit the aperture 42 to assume a position

in general alignment with housing axis "a".

**[0019]** With reference to FIG. 5, in conjunction with FIGS. 1-2, second seal 22 includes outer seal portion 44 and inner seal portion 46. Outer seal portion 44 also includes apertures 48 disposed about its periphery for reception of posts 32 of seal support 18 to mount the second seal 22 within housing member 16. Inner seal portion 46 defines opening or aperture 50 which may be of any geometrical shape, but, preferably, is generally D-shaped. Aperture 50 is arranged to be a mirror image of aperture 42 of first seal 20. Aperture 50 is arranged about second seal axis "d" which is radially offset from housing axis "a". Alternatively, as depicted in FIG. 5A, aperture 50 may be centrally located within second seal 22 with second seal axis "d" coincident with axis "a" of housing member 16. This arrangement may minimize the degree of movement required by first seal 20 and also positions the object in the center of housing member 16 during use. Second seal 22 may optionally include expandable ribs of the type aforescribed in connection with first seal 20.

**[0020]** First and second seals 20, 22 are each adapted to form a substantial seal about an object inserted through their apertures 42, 50 and may stretch to accommodate larger size objects. First and second seals 20, 22 are preferably in juxtaposed contacting relation. First and second seals 20, 22 may be formed of an elastomeric material including commercially available MONOPRENE™. In one preferred embodiment, seals 20, 22 are fabricated from a resilient material, e.g., polyisoprene, with each having at least one layer of fabric material positioned adjacent the resilient material. Seals 20, 22 may be fabricated from an elastomeric material molded with a fabric material. A friction resisting coating may be applied to seals 20, 22. Such seal is disclosed in commonly-assigned U.S. Patent Application Serial No. 10/165,373 filed June 6, 2002.

**[0021]** FIG. 6 illustrates in plan view the arrangement of first and second seals 20, 22 (with second seal 22 shown in phantom) prior to insertion of an object within the apertures 42, 50 of the seals 20, 22. As shown, apertures 42, 50 of first and second seals 20, 22 are in non-overlapping relation, and arranged so that the respective apertures of the first and second seal do not overlap. With this arrangement and with first and second seals 20, 22 in contacting relation, the seals 20, 22 substantially seal longitudinal passageway 28 of housing member 16 to prevent escape of insufflation gases through access housing 12.

**[0022]** Referring again to FIGS. 1-2, liner base 14 of access apparatus 10 will be discussed. Liner base 14 is intended for positioning within the incision of the patient to line the incision and/or retract the tissue defining the incision thereby providing access to the underlying body cavity. Liner base 14 includes liner member 52, and lower ring 54 and upper ring 56 mounted to respective ends of liner member 52. Liner member 52 may be a sheet of flexible material including, for example, polyethylene,

polypropylene, etc., arranged in a tubular or sleeve-like configuration.

**[0023]** Liner member 52 may also include an elastomeric material and may incorporate rigid runners embedded within the material to increase its rigidity. Although in the preferred embodiment, liner member 52 is tubular, it is envisioned that the liner member 52 may incorporate several pieces, e.g., individual tabs or the like. Liner member 52 may or may not be impervious to fluids. Liner member 52 is adapted to line the incision so as to prevent contamination of the incision by any tissue which may be removed through the access apparatus, or in the course of the surgery. Generally, liner member 52 may also serve to retract the incision during placement of the liner base 14, so that the patient's skin, fascia, and other tissue are drawn back, allowing access to the surgical site.

**[0024]** Lower ring 54 of liner member 52 is adapted for positioning through the incision and beneath the abdominal wall to engage the interior wall portions to thereby secure liner base 14 relative to the incision. Lower ring 54 is preferably flexible to facilitate passage through the incision and possesses sufficient resiliency to return to its original configuration upon entering the abdominal cavity. Lower ring 54 is preferably annular or ring-like in configuration and may be fabricated from a resilient or elastomeric material. Lower ring 54 may be fixedly secured to the end of liner member 52 through conventional means.

**[0025]** Upper ring 56 is substantially identical to lower ring 54, i.e., upper ring 56 is also annular or ring-like in configuration and is attached to the other end of liner member 52 by conventional means. Upper ring 56 is received within U-shaped flange 26 of access housing 12 and is secured between the flange 26 and lower surface 58 of seal support 18 to secure liner base 14 to access housing 12. Other means for attaching upper ring 56 to access housing 12 are also envisioned.

**[0026]** In further embodiments, seal support 18 discussed above in connection with FIGS. 1-9 is mounted to a different base for retracting the incision and preferably lining the incision. For example, the base 14 may comprise a flexible sleeve for lining the incision and an inflatable member at a proximal end of the sleeve for tensioning the sleeve. Other structures for the base 14 may be used as appreciated by those of ordinary skill in the art. The access apparatus 10 discussed above may also include an additional seal for sealing around the object inserted through the apparatus, such as a septum seal.

### Operation

**[0027]** The use of the access apparatus 10 in connection with a hand assisted laparoscopic surgical procedure will be discussed. The peritoneal cavity is insufflated and an incision is made within the cavity, with e.g., a trocar, to provide access to the cavity as is conventional in the art. Thereafter, as depicted in FIGS. 7-8, liner base 14

is introduced within the incision. Specifically, lower ring 54 is passed through the incision "i" and placed within the body cavity. As noted, lower ring 54 may be contracted upon itself to facilitate passage through the incision "i" and then released to permit the lower ring 54 to return to its normal condition (under the influences of its inherent resiliency) within the cavity. Liner member 52 extends from lower ring 54 through the incision to line the incision as previously discussed.

**[0028]** With reference to FIG. 9, the procedure is continued by positioning access housing 12 adjacent the external body tissue with the outer surface of U-shaped flange 26 engaging the tissue surrounding the incision. Thereafter, an object such as the surgeon's hand or arm "o" is introduced within access housing 12 and advanced through aperture 42 of first seal 20. As noted, inner seal portion 36 of first seal 20 moves radially as facilitated by expansion of ribs 40 to permit aperture 42 to at least partially overlap with aperture 50 of second seal 22 thereby permitting the surgeon to continue advancing his arm through access housing 12 and liner base 14. The surgeon continues to advance his arm through aperture 50 of second seal 22 and within the abdominal cavity.

**[0029]** With access apparatus 10 in this position of FIG. 9, hand assisted surgery may then be effected by continued advancement of the surgeon's hand and arm through seals 20, 22 of access housing 12 and into the body cavity. Seals 20, 22 form a fluid tight seal about the arm. The desired hand assisted procedure may then be performed.

**[0030]** It will be understood that various modifications may be made to the embodiments disclosed herein. Therefore, the above description should not be construed as limiting, but merely as exemplifications of preferred embodiments. Those skilled in the art will envision other modifications within the scope of the claims appended hereto.

### **Claims**

1. A surgical access apparatus (10) which comprises:

a housing member (16) defining a housing axis ("a") and a passageway (28) therethrough; and a first seal member (20) mounted across the passageway (28), the first seal member (20) including an inner seal portion (36) and an outer seal portion (34), the inner seal portion (36) having an aperture (42) for substantial sealed reception of an object ("o") inserted therein and being arranged about a first seal axis ("c");

**characterized by:**

the outer seal portion (34) including at least one expansible rib (40) dimensioned to facilitate movement of the aperture (42) to a displaced position radially displaced from

- the first seal ("c") upon insertion of the object ("o") therethrough, the at least one expansible rib (40) being generally arranged along a line of intersection ("b") with the housing axis ("a").
2. The surgical access apparatus (10) according to claim 1 further comprising a second seal member (22) mounted across the passageway (28) adjacent the first seal member (20), the second seal member (22) having an inner portion (46) defining an aperture (50) for substantial sealed reception of the object ("o") and being arranged about a second seal axis ("d") radially displaced from the first seal axis ("c").
  3. The surgical access apparatus (10) according to claim 2 wherein the first and second seal members (20, 22) are arranged so that their respective apertures (42, 50) do not overlap in the absence of the object ("o") positioned therein.
  4. The surgical access apparatus (10) according to any one of claims 2 or 3 wherein the first seal member (20) is adapted to move to the displaced position upon insertion of the object ("o") therethrough whereby the apertures (42, 50) of the first seal member (20) and the second seal member (22) overlap.
  5. The surgical access apparatus (10) according to any one of claims 2, 3 or 4 wherein the first and second seal members (20, 22) are adapted to form a substantial seal within the passageway (28) of the housing member (16) in the absence of the object ("o") inserted within the aperture (42) of the first member (20).
  6. The surgical access apparatus (10) according to any one of the preceding claims, including a plurality of expansible ribs (40) about the outer seal portion (34) of the first seal member (20).
  7. The surgical access apparatus (10) according to any one of claims 2, 3, 4, 5 or 6 including a plurality of expansible ribs (40) about the outer seal portion (44) of the second seal member (22).
  8. The surgical access apparatus (10) according to any one of the preceding claims further comprising a liner base (14) mountable to the housing member (16), the liner base (14) adapted for insertion through an incision ("i") to line the incision and/or retract the tissue defining the incision thereby providing access to the underlying body cavity.
  9. The surgical access apparatus (10) according to any one of the preceding claims wherein the aperture (42) of the first seal member (20) is adapted for substantial sealed reception of either a surgeon's hand

or arm ("o").

10. The surgical access apparatus (10) according to claim 6 wherein the expansible ribs (40) define one of an undulating, sinusoidal, pyramidal, convex, or concave configuration.

## Patentansprüche

1. Chirurgische Zugangsvorrichtung (10), die umfasst:
  - ein Gehäuseelement (16), das eine Gehäuseachse ("a") und einen Durchgang (28) **dadurch** definiert, und
  - ein erstes Dichtelement (20), das quer zum Durchgang (28) angebracht ist, wobei das erste Dichtelement (20) einen inneren Dichtteil (36) und einen äußeren Dichtteil (34) enthält, wobei der innere Dichtteil (36) eine Öffnung (42) für eine im Wesentlichen abgedichtete Aufnahme eines darin eingeführten Objekts ("o") aufweist und um eine erste Dichtachse ("c") angeordnet ist,
  - dadurch gekennzeichnet, dass** der äußere Dichtteil (34) zumindest eine dehnbare Rippe (40) aufweist, die bemessen ist, um eine Bewegung der Öffnung (42) zu einer versetzten Position, die radial gegenüber der ersten Dichtung ("c") versetzt ist, nach einem Einführen des Objekts ("o") **dadurch** zu erleichtern, wobei die zumindest eine dehnbare Rippe (40) im Allgemeinen entlang einer mit der Gehäuseachse ("a") kreuzenden Linie ("b") angeordnet ist.
2. Chirurgische Zugangsvorrichtung (10) nach Anspruch 1, ferner umfassend ein zweites Dichtelement (22), das quer zu dem Durchgang (28) neben dem ersten Dichtelement (20) angebracht ist, wobei das zweite Dichtelement (22) einen inneren Teil (46) aufweist, der eine Öffnung (50) für eine im Wesentlichen abgedichtete Aufnahme des Objekts ("o") definiert und um eine zweite Dichtachse ("d") angeordnet ist, die radial zu der ersten Dichtachse ("c") versetzt ist.
3. Chirurgische Zugangsvorrichtung (10) nach Anspruch 2, wobei die ersten und zweiten Dichtelemente (20, 22) so angeordnet sind, dass ihre jeweiligen Öffnungen (42, 50) in der Abwesenheit des darin positionierten Objekts ("o") nicht überlappen.
4. Chirurgische Zugangsvorrichtung (10) nach einem der Ansprüche 2 oder 3, wobei das erste Dichtelement (20) eingerichtet ist, sich zu der versetzten Position nach dem Einführen des Objekts ("o") **dadurch** zu bewegen, wodurch die Öffnungen (42, 50)

des ersten Dichtelements (20) und des zweiten Dichtelements (22) überlappen.

5. Chirurgische Zugangsvorrichtung (10) nach einem der Ansprüche 2, 3 oder 4, wobei die ersten und zweiten Dichtelemente (20, 22) eingerichtet sind, im Wesentlichen eine Dichtung innerhalb des Durchgangs (28) des Gehäuseelements (16) in der Abwesenheit des in die Öffnung (42) des ersten Elements (20) eingeführten Objekts ("o") zu bilden. 5
6. Chirurgische Zugangsvorrichtung (10) nach einem der vorstehenden Ansprüche, enthaltend eine Mehrzahl von dehnbaren Rippen (40) um den äußeren Dichtteil (34) des ersten Dichtelements (20). 10
7. Chirurgische Zugangsvorrichtung (10) nach einem der Ansprüche 2, 3, 4, 5 oder 6, enthaltend eine Mehrzahl dehnbare Rippen (40) um den äußeren Dichtteil (44) des zweiten Dichtelements (22). 20
8. Chirurgische Zugangsvorrichtung (10) nach einem der vorstehenden Ansprüche, ferner umfassend einen Abdichtungsgrund (14), der an dem Gehäuseelement (16) anbringbar ist, wobei der Abdichtungsgrund (14) zum Einsetzen durch einen Einschnitt ("i") eingerichtet ist, um den Einschnitt abzudichten und/oder das Gewebe, das den Einschnitt definiert, zurückzuziehen und **dadurch** einen Zugang zu der darunter liegenden Körperöffnung zu schaffen. 30
9. Chirurgische Zugangsvorrichtung (10) nach einem der vorstehenden Ansprüche, wobei die Öffnung (42) des ersten Dichtelements (20) für eine im Wesentlichen abgedichtete Aufnahme entweder einer Hand oder eines Arms ("o") eines Chirurgen eingerichtet ist. 35
10. Chirurgische Zugangsvorrichtung (10) nach Anspruch 6, wobei die dehnbaren Rippen (40) eine gewellte, sinusförmige, pyramidale, konvexe oder konkave Einstellung definieren. 40

#### Revendications

1. Appareil d'accès chirurgical (10) qui comprend:

un élément de boîtier (16) définissant un axe de boîtier (« a ») et un passage (28) à travers celui-ci; et 50

un premier élément d'étanchéité (20) monté sur le passage (28), le premier élément d'étanchéité (20) incluant une portion d'étanchéité intérieure (36) et une portion d'étanchéité extérieure (34), la portion d'étanchéité intérieure (36) ayant une ouverture (42) pour la réception sensiblement étanche d'un objet (« o ») inséré dans celle-ci 55

et étant agencée autour d'un premier axe d'étanchéité (« c ») ;

#### caractérisé par

la portion d'étanchéité extérieure (34) incluant au moins une nervure expansible (40) dimensionnée pour faciliter le mouvement de l'ouverture (42) à une position déplacée, radialement déplacée de la première étanchéité (« c ») lors de l'insertion de l'objet (« o ») à travers celle-ci, la au moins une nervure expansible (40) étant généralement agencée le long d'une ligne d'intersection (« b ») avec l'axe de boîtier (« a »).

2. Appareil d'accès chirurgical (10) selon la revendication 1, comprenant en outre un deuxième élément d'étanchéité (22) monté sur le passage (28) d'une manière adjacente au premier élément d'étanchéité (20), le deuxième élément d'étanchéité (22) ayant une portion intérieure (46) définissant une ouverture (50) pour la réception sensiblement étanche de l'objet (« o ») et étant agencée autour d'un deuxième axe d'étanchéité (« d ») radialement déplacée du premier axe d'étanchéité (« c »). 15
3. Appareil d'accès chirurgical (10) selon la revendication 2, où les premier et deuxième éléments d'étanchéité (20, 22) sont agencés de telle sorte que leurs ouvertures respectives (42, 50) ne se chevauchent pas en l'absence de l'objet (« o ») positionné dans celles-ci. 25
4. Appareil d'accès chirurgical (10) selon l'une quelconque des revendications 2 ou 3, où le premier élément d'étanchéité (20) est apte à rejoindre la position déplacée lors de l'insertion de l'objet (« o ») à travers celui-ci par quoi les ouvertures (42, 50) du premier élément d'étanchéité (20) et du deuxième élément d'étanchéité (22) se chevauchent. 30
5. Appareil d'accès chirurgical (10) selon l'une quelconque des revendications 2, 3 ou 4, où les premier et deuxième éléments d'étanchéité (20, 22) sont aptes à former un joint d'étanchéité substantiel dans le passage (28) de l'élément de boîtier (16) en l'absence de l'objet (« o ») inséré dans l'ouverture (42) du premier élément (20). 35
6. Appareil d'accès chirurgical (10) selon l'une quelconque des revendications précédentes, incluant une pluralité de nervures expansibles (40) autour de la portion d'étanchéité extérieure (34) du premier élément d'étanchéité (20). 40
7. Appareil d'accès chirurgical (10) selon l'une quelconque des revendications 2, 3, 4, 5 ou 6 incluant une pluralité de nervures expansibles (40) autour de la portion d'étanchéité extérieure (44) du deuxième élément d'étanchéité (22). 45

8. Appareil d'accès chirurgical (10) selon l'une quelconque des revendications précédentes, comprenant en outre une base de revêtement (14) pouvant être montée sur l'élément de boîtier (16), la base de revêtement (14) étant apte à être insérée à travers une incision (« i ») pour revêtir l'incision et/ou rétracter le tissu définissant l'incision en réalisant ainsi un accès à la cavité corporelle située en dessous. 5
9. Appareil d'accès chirurgical (10) selon l'une quelconque des revendications précédentes, où l'ouverture (42) du premier élément d'étanchéité (20) est conçue pour une réception sensiblement étanche soit de la main soit du bras (« o ») d'un chirurgien. 10  
15
10. Appareil d'accès chirurgical (10) selon la revendication 6, où les nervures expansibles (40) définissent une parmi une configuration ondulée, sinusoïdale, pyramidale, convexe ou concave. 20

25

30

35

40

45

50

55

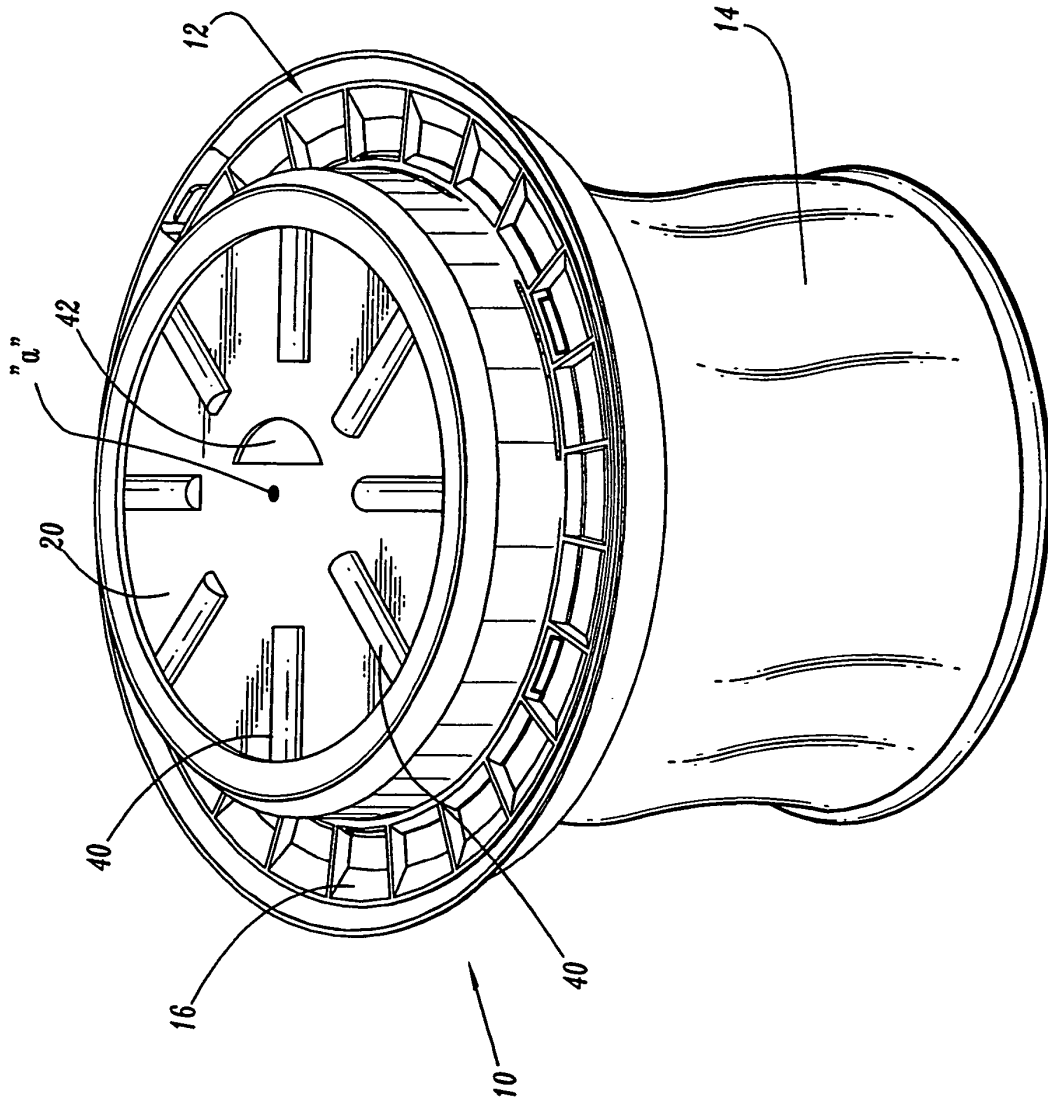
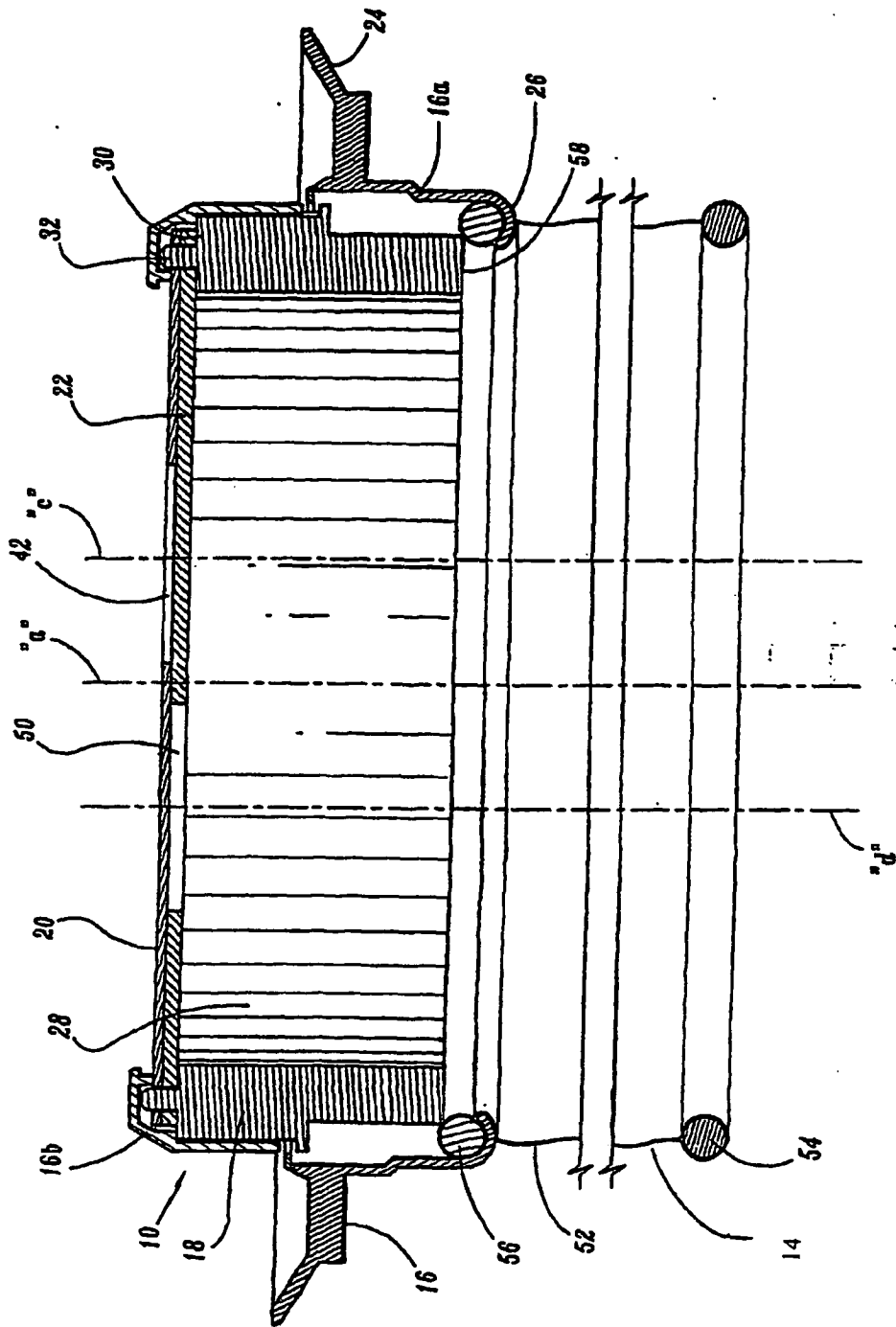
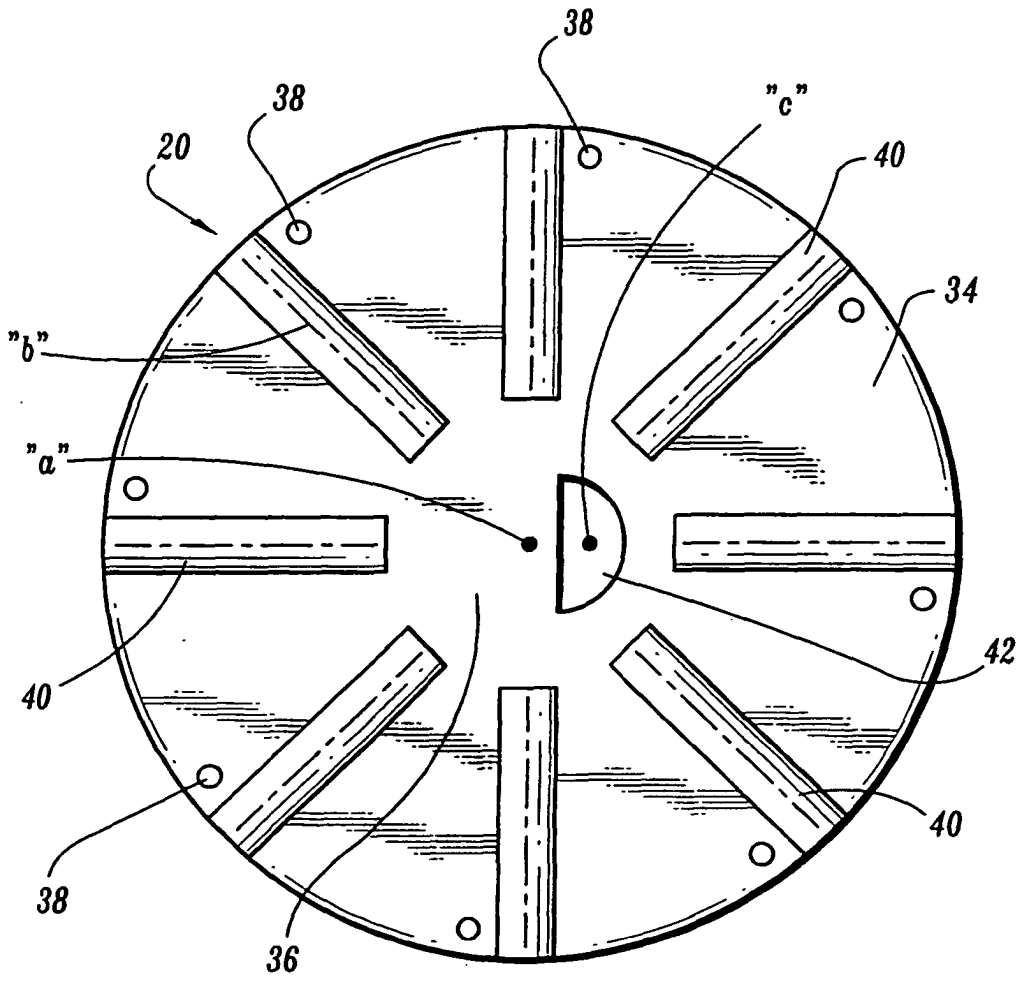
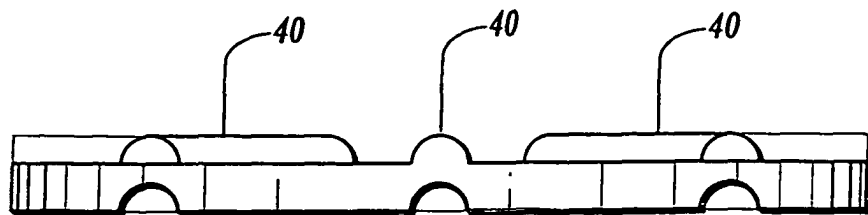


FIG. 1

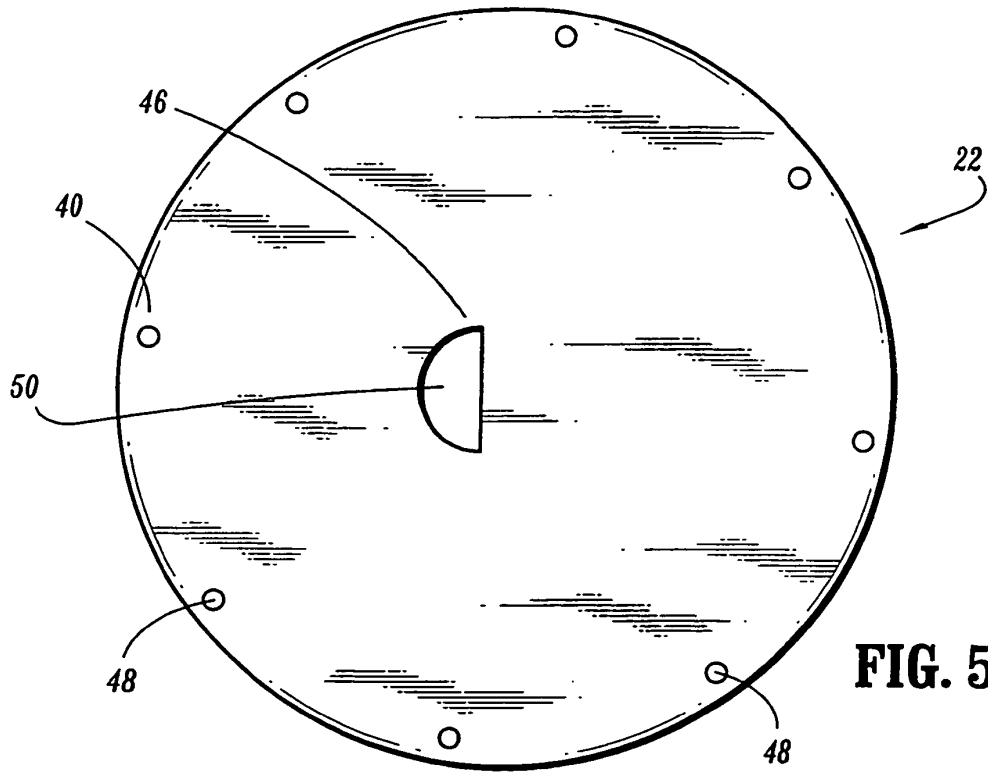




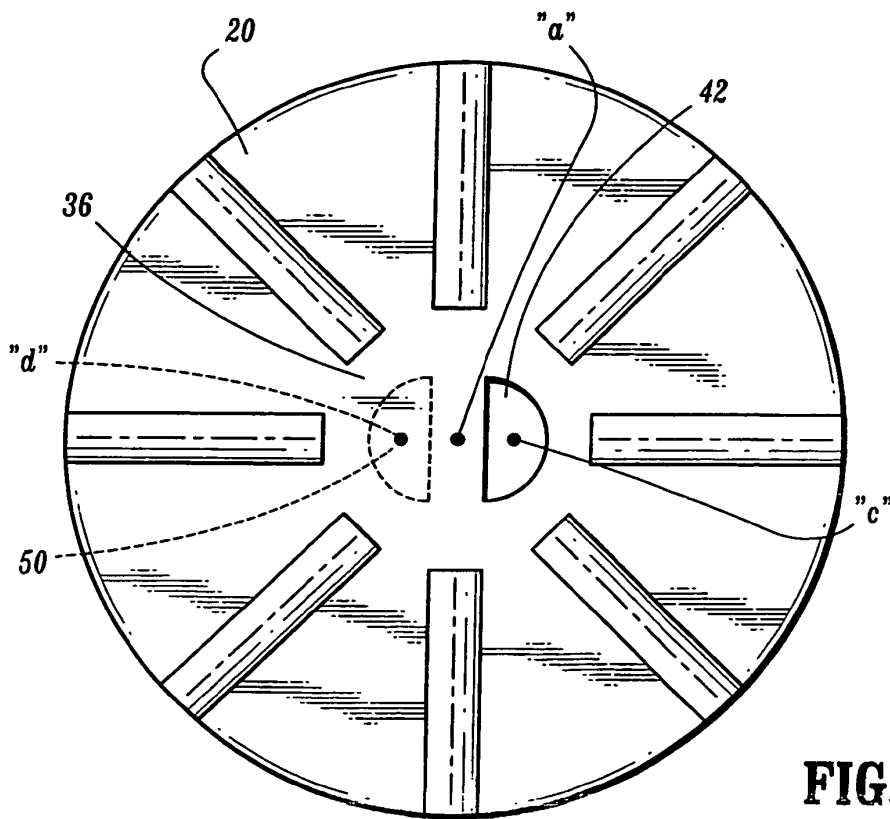
**FIG. 3**



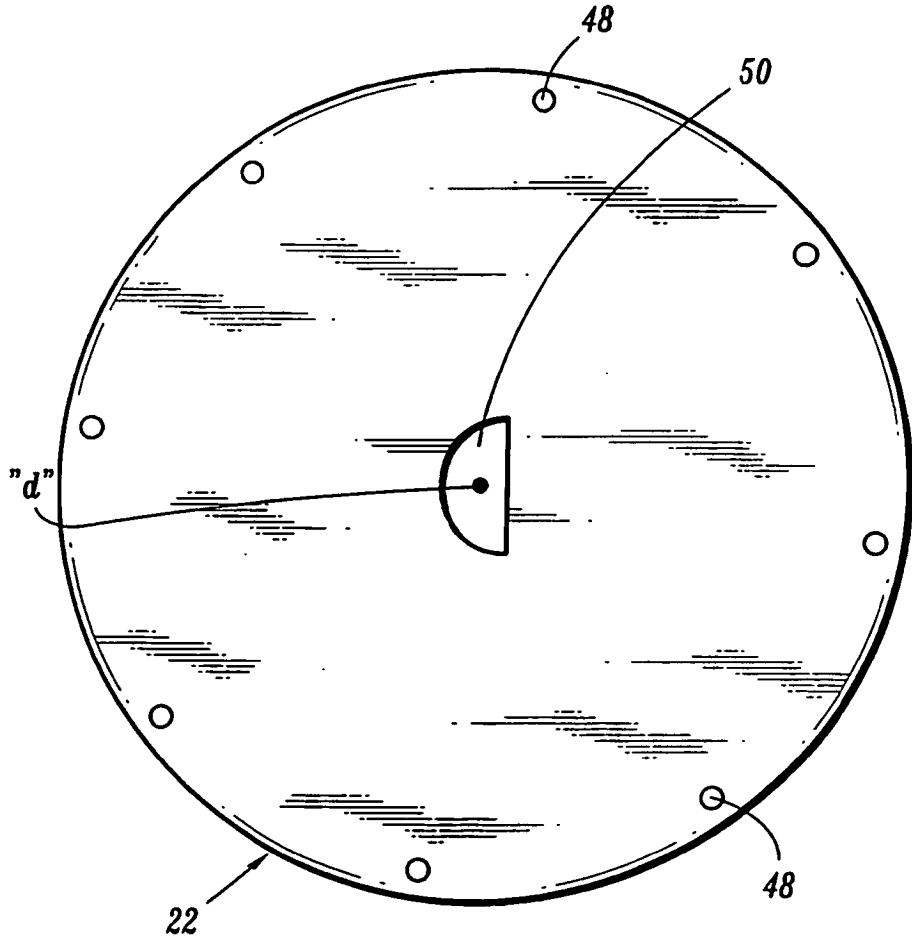
**FIG. 4**



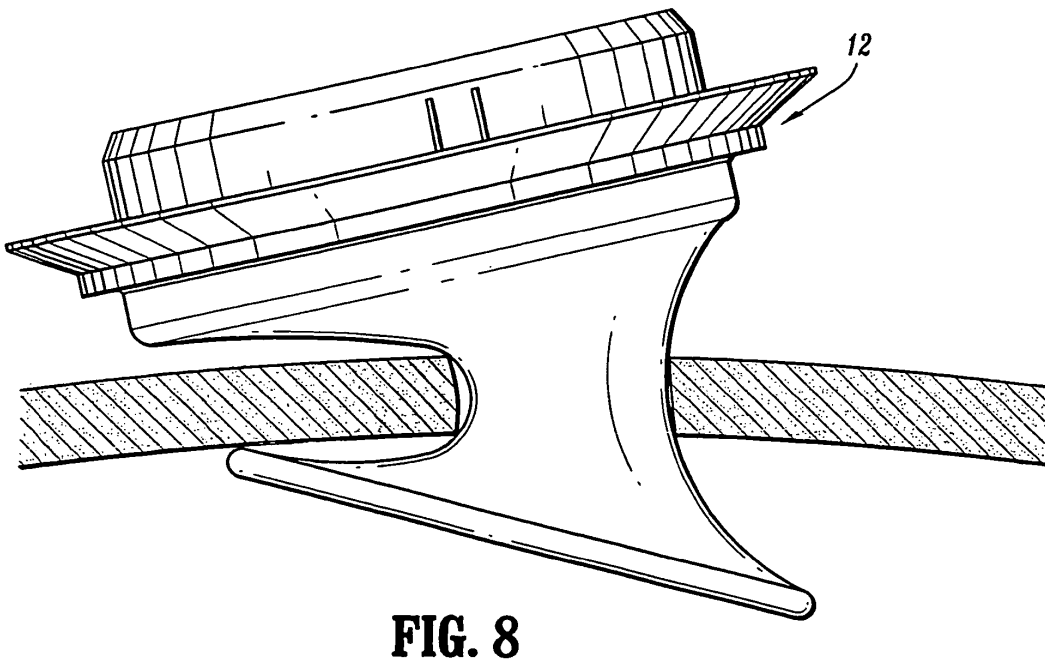
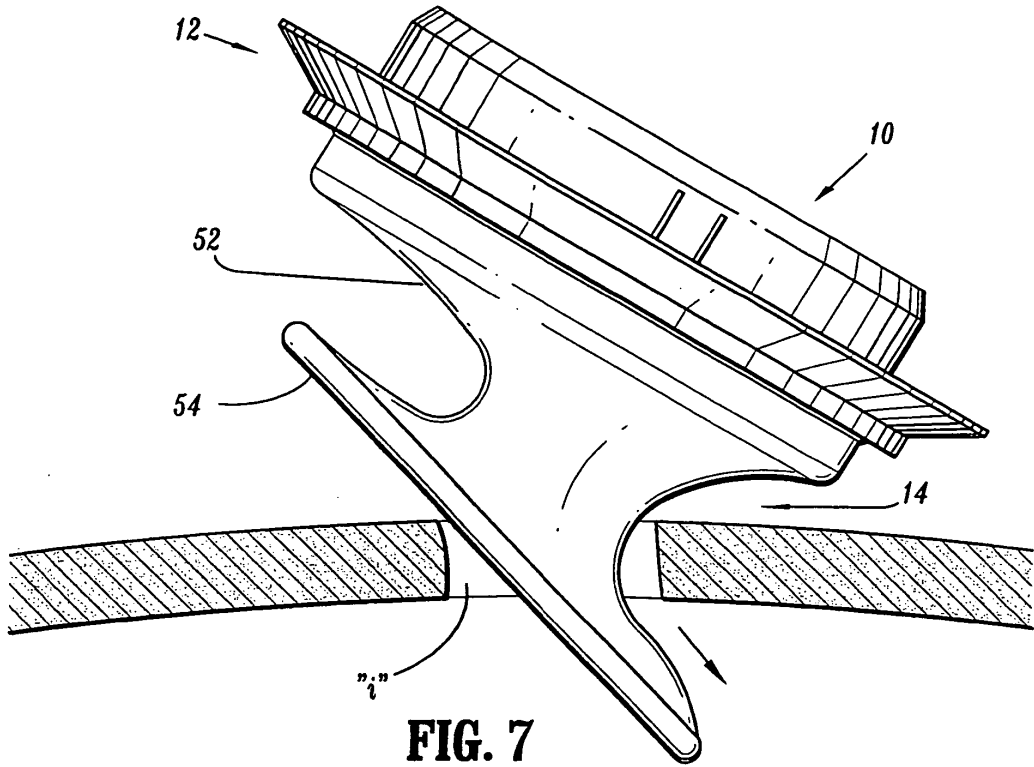
**FIG. 5**

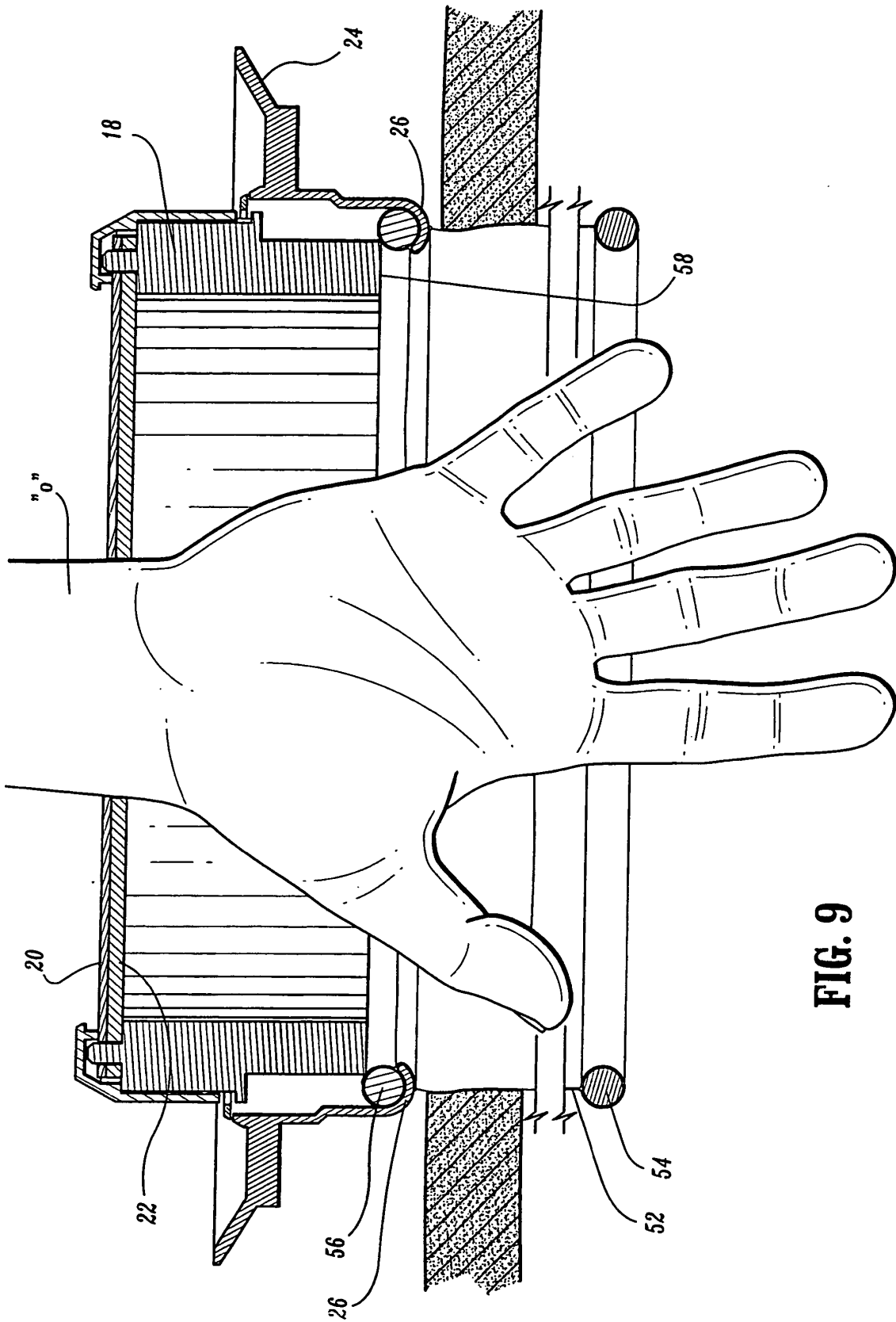


**FIG. 6**



**FIG. 5A**





**FIG. 9**

**REFERENCES CITED IN THE DESCRIPTION**

*This list of references cited by the applicant is for the reader's convenience only. It does not form part of the European patent document. Even though great care has been taken in compiling the references, errors or omissions cannot be excluded and the EPO disclaims all liability in this regard.*

**Patent documents cited in the description**

- US 6086570 A, Aboul-Hosn [0005]
- US 5411483 A, Loomas [0006]
- US 6033426 A, Kaji [0007]
- US 16537302 A [0020]

专利名称(译)	手术进入装置		
公开(公告)号	<a href="#">EP1707235B1</a>	公开(公告)日	2009-01-07
申请号	EP2006005181	申请日	2006-03-14
[标]申请(专利权)人(译)	柯惠有限合伙公司		
申请(专利权)人(译)	泰科医疗集团LP		
当前申请(专利权)人(译)	泰科医疗集团LP		
[标]发明人	JENSEN DAVID WENCHELL THOMAS		
发明人	JENSEN, DAVID WENCHELL, THOMAS		
IPC分类号	A61M39/06 A61B17/34		
CPC分类号	A61B17/3423 A61B2017/00265 A61M39/0606		
优先权	11/095340 2005-03-31 US		
其他公开文献	EP1707235A1		
外部链接	<a href="#">Espacenet</a>		

摘要(译)

一种外科进入装置，其适于允许在腹腔镜和内窥镜外科手术过程中密封插入外科医生的手和/或外科手术器械，包括具有穿过其中的通道的进入构件以及跨越通道安装的第一和第二密封构件。第一密封件包括内密封部分和外密封部分。内密封部分具有孔，用于基本上密封接收插入其中的物体，并且围绕第一密封轴线布置。外密封部分包括至少一个可膨胀肋，其尺寸被设计成便于在物体插入时从孔移动到从第一密封轴径向移位的移位位置。第二密封构件还具有内部部分，该内部部分限定用于基本上密封接收的孔该物体围绕从第一密封轴线径向移位的第二密封轴线布置。优选地，在没有物体定位于其中的情况下，第一和第二密封构件的孔处于非重叠关系。第一密封构件适于在物体插入时移动到移位位置，由此第一密封构件和第二密封构件的孔重叠。第一和第二密封构件优选地适于在没有物体插入第一构件的孔内的情况下在进入构件的通道内形成基本密封。第一密封构件的外密封部分可包括多个可膨胀肋。可膨胀肋可以沿着与第一密封构件的轴线相交的相应线布置。

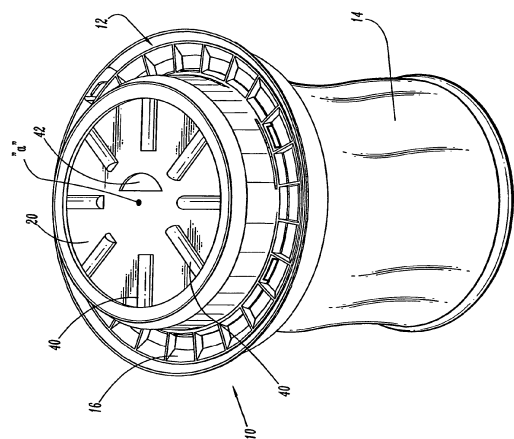


FIG. 1