

(19) World Intellectual Property Organization  
International Bureau



(43) International Publication Date  
12 May 2011 (12.05.2011)

PCT

(10) International Publication Number  
**WO 2011/057282 A2**

(51) International Patent Classification:

A61B 17/04 (2006.01) A61M 25/01 (2006.01)  
A61B 17/34 (2006.01)

(21) International Application Number:

PCT/US2010/056059

(22) International Filing Date:

9 November 2010 (09.11.2010)

(25) Filing Language:

English

(26) Publication Language:

English

(30) Priority Data:

61/280,896 9 November 2009 (09.11.2009) US  
12/757,275 9 April 2010 (09.04.2010) US

(71) Applicant (for all designated States except US): **CARDIOVASCULAR TECHNOLOGIES, INC.** [US/US];  
1787 Verdite Street, Livermore, CA 94550 (US).

(72) Inventors; and

(75) Inventors/Applicants (for US only): **HOUSER, Russell, A.** [US/US]; 4574 Country Lane, Livermore, CA 94550 (US). **BOWER, John, Hunter** [US/US]; 651 South N Street, Livermore, CA 94550 (US).

(74) Agents: **KIM, Elaine, A.** et al.; Wilson Sonsini Goodrich & Rosati, 650 Page Mill Road, Palo Alto, CA 94304-1050 (US).

(81) Designated States (unless otherwise indicated, for every

kind of national protection available): AE, AG, AL, AM, AO, AT, AU, AZ, BA, BB, BG, BH, BR, BW, BY, BZ, CA, CH, CL, CN, CO, CR, CU, CZ, DE, DK, DM, DO, DZ, EC, EE, EG, ES, FI, GB, GD, GE, GH, GM, GT, HN, HR, HU, ID, IL, IN, IS, JP, KE, KG, KM, KN, KP, KR, KZ, LA, LC, LK, LR, LS, LT, LU, LY, MA, MD, ME, MG, MK, MN, MW, MX, MY, MZ, NA, NG, NI, NO, NZ, OM, PE, PG, PH, PL, PT, RO, RS, RU, SC, SD, SE, SG, SK, SL, SM, ST, SV, SY, TH, TJ, TM, TN, TR, TT, TZ, UA, UG, US, UZ, VC, VN, ZA, ZM, ZW.

(84) Designated States (unless otherwise indicated, for every

kind of regional protection available): ARIPO (BW, GH, GM, KE, LR, LS, MW, MZ, NA, SD, SL, SZ, TZ, UG, ZM, ZW), Eurasian (AM, AZ, BY, KG, KZ, MD, RU, TJ, TM), European (AL, AT, BE, BG, CH, CY, CZ, DE, DK, EE, ES, FI, FR, GB, GR, HR, HU, IE, IS, IT, LT, LU, LV, MC, MK, MT, NL, NO, PL, PT, RO, RS, SE, SI, SK, SM, TR), OAPI (BF, BJ, CF, CG, CI, CM, GA, GN, GQ, GW, ML, MR, NE, SN, TD, TG).

Published:

— without international search report and to be republished upon receipt of that report (Rule 48.2(g))

(54) Title: TISSUE CLOSURE DEVICES, DEVICE AND SYSTEMS FOR DELIVERY, KITS AND METHODS THEREFOR

(57) Abstract: The present invention relates to tissue closure devices, devices and systems for delivery, kits and methods therefor. The tissue closure devices can achieve tissue closure in lieu of compression and can be configured to be quickly deployable by an introducer or from outside the body.



WO 2011/057282 A2

**TISSUE CLOSURE DEVICES, DEVICE AND SYSTEMS  
FOR DELIVERY, KITS AND METHODS THEREFOR**

**CROSS-REFERENCE**

[0001] This application claims the benefit of U.S. Provisional Patent Application **61/280,896** filed November 9, 2009, entitled "Bioabsorbable Plug Tissue Closure System," and is also a continuation-in-part of and claims priority to U.S. Patent Application Serial No. **12/757,275** filed April 9, 2010, entitled "Tissue Closure Devices, Device and Systems for Delivery, Kits and Methods Therefor," which claims the benefit of U.S. Provisional Patent Applications **61/212,296**, filed April 9, 2009, entitled "Introducer Sheath Adapter for the Atraumatic Delivery of a Medical Device," **61/277,359** filed September 21, 2009, entitled "Tissue Closure Device Systems and Methods," and **61/280,896** filed November 9, 2009, entitled "Bioabsorbable Plug Tissue Closure System," and which is a continuation-in-part of **12/327,655** filed December 3, 2008, titled "Guided Tissue Cutting Device, Methods, of Use and Kits Therefor," which is a continuation-in-part of **12/263,322** filed October 31, 2008, titled "Vascular Closure Devices, Systems, and Methods of Use," which claims the benefit of U.S. Priority Patent Applications **61/005,435**, filed December 3, 2007 and entitled "Guided Tissue Cutting Device and Method of Use," **61/190,100**, filed August 26, 2008 and entitled "Tissue Closure Devices, Systems and Methods of Use," and which in turn is a continuation-in-part of **10/183,396** filed June 28, 2002, now U.S. Patent **6,726,696** which is a continuation-in-part of **10/127,714**, filed April 23, 2002 and entitled "Arteriotomy Closure Devices and Techniques," and claims the benefit of priority from U.S. Provisional Patent Application Nos. **60/286,269**, filed April 24, 2001 and entitled "Percutaneous Vessel Access Closure Device and Method," **60/300,892**, filed June 25, 2001 and entitled "Percutaneous Vessel Access Closure Device and Method," **60/302,255**, filed June 28, 2001 and entitled "Percutaneous Vessel Access Closure Device and Method (Hemostatic Patch or Collar)," the disclosures of which are hereby incorporated by reference herein in their entirety and made a part of the present specification.

**TECHNICAL FIELD**

[0002] The invention generally relates to medical devices and techniques, and more particularly to cardiovascular tissue closure devices, systems, techniques and kits.

**BACKGROUND OF THE INVENTION**

[0003] In most cardiology and radiology procedures, a catheter is inserted into an artery, such as the femoral artery, through a vascular introducer. When the procedure is complete, the physician removes the catheter from the introducer and then removes the introducer from the arteriotomy or incision or opening into the lumen in the vessel. The physician then must prevent or limit the amount of blood that leaks through the arteriotomy so that the patient can be discharged. Physicians currently use a number of methods to close the arteriotomy, such as localized compression, sutures, collagen plugs, adhesives, gels, foams, clips, and similar materials.

[0004] In performing localized compression, the physician presses down against the vessel to allow the arteriotomy to naturally clot. This method, however, can take a significant amount of time, and requires the patient to remain immobilized and kept in the hospital for observation. Moreover, clots at the puncture site may also be dislodged. The amount of time necessary for the compression can significantly increase  
5 depending upon how much heparin, glycoprotein IIb/IIA antagonists, or other anti-clotting agents were used during the procedure. Sutures and collagen plugs can have procedure variability, can require time to close the vessel, and can necessitate a separate deployment device. Adhesives, gels, foams, and clips can have negative cost factors, can necessitate a complicated deployment process, and can have procedure variability.

#### SUMMARY OF THE INVENTION

[0005] An aspect of the disclosure is directed to a closure device. The closure devices comprises: a distal flexible cap; and may have one or more proximally positioned radial extending elements; a stem positioned between the distal flexible cap and the one or more radial extending element, wherein the distal flexible cap is formable toward an axis. In at least some configurations, the distal flexible cap can be configured such that it has at least one of a substantially flat distal surface and a substantially flat proximal surface, a substantially  
15 flat distal surface and a substantially concave proximal surface, a substantially flat distal surface and a substantially convex proximal surface, a substantially convex distal surface and a substantially flat proximal surface, a substantially convex distal surface and a substantially convex proximal surface, a substantially convex distal surface and a substantially concave proximal surface, a substantially concave distal surface and a substantially flat proximal surface, a substantially concave distal surface and a substantially concave  
20 proximal surface, and a substantially concave distal surface and a substantially convex proximal surface. Additionally, the distal flexible cap can have at least one of a uniform thickness in a cross-section or a variable thickness in a cross-section. In some configurations, the proximal surface of the distal flexible cap has one of more of at least one of anchoring protrusions, nibs or ribs. The distal flexible cap can also be configured to have a shape selected from round, triangular, oval, ovoid, elliptical, square, and saucer. The  
25 flexible cap shape can have rounded edges. Additionally, the stem can be positioned on a proximal surface of the flexible cap at least one of centrally and non-centrally. A proximally accessible stem bore can also be provided. Additionally, a clip can be positionable within the proximal bore. The proximally accessible stem bore can also have at least one of internal threads along an interior surface, parallel walls along its length, non-parallel walls along its length, an undercut in the bore at a location along its length, and a bent bore along its  
30 length. Additionally, the bore can be configured to extend from the proximal end of the device to the proximal end of the flexible cap. A wide variety of configurations for the stem are possible as will be appreciated. A few of the configurations include, for example, cross-sectional profile shapes selected from the group comprising square, triangular, arrowhead, trapezoidal, rectangular, J, Y, hook, and bulbous. The stem can further comprise a proximally positioned aperture therethrough, one or more exterior features adapted and  
35 configured to achieve anchoring the stem in vivo, one or more slots along at least a portion of its length parallel to a stem longitudinal axis beginning at its proximal end, a configuration which enables it to open

away from the longitudinal axis from its proximal end, a proximal end adapted and configured to form a clasp, a socket, a breakable stem, a tearable stem, and/or at least one of the distal flexible cap and stem are in releasable communication with a tether. Additionally, a tether can be provided. The tether can be one or more of a wire, a spring, a thread, a ribbon, and a tube. Wire can at least be one of a bent wire, a curved wire, a wavy wire, and a helical wire.

**[0006]** Another aspect of the disclosure is directed to a delivery capsule. The delivery capsule comprises: a cartridge body; a tapered distal tip; a compressible section; a clear section; a lumen extending therethrough, wherein the clear section is adapted and configured to house a closure device. The delivery capsule can be further adapted and configured to comprise a valve, one or more proximally positioned detent features on an exterior surface of the cartridge body, one or more distally positioned undercuts, an exterior groove in the cartridge body, a one-way snap feature, an undercut central bore, and/or a central aperture adapted and configured to receive a plunger. Where the capsule receives a plunger it can further be configured to permit the plunger to move in a first axial direction and resist movement in a second axial direction different than the first direction. One or more collets can also be provided.

**[0007]** Still another aspect of the disclosure is directed to a tissue closure delivery system. The tissue closure delivery system comprises: an introducer; a tissue closure delivery cartridge; a guide and seal assembly; and a plunger wherein the introducer is adapted and configured to releasably engage the tissue closure delivery cartridge at a proximal end, the tissue closure delivery cartridge is adapted and configured to releasably engage the guide and seal assembly at a proximal end, and the plunger is adapted and configured to be advanced through a lumen in each of the guide and seal assembly, the tissue closure delivery cartridge and the introducer. In at least some configurations, the distal flexible cap can be configured such that it has at least one of a substantially flat distal surface and a substantially flat proximal surface, a substantially flat distal surface and a substantially concave proximal surface, a substantially flat distal surface and a substantially convex proximal surface, a substantially convex distal surface and a substantially flat proximal surface, a substantially convex distal surface and a substantially convex proximal surface, a substantially convex distal surface and a substantially concave proximal surface, a substantially concave distal surface and a substantially flat proximal surface, a substantially concave distal surface and a substantially concave proximal surface, and a substantially concave distal surface and a substantially convex proximal surface. Additionally, the distal flexible cap can have at least one of a uniform thickness in a cross-section or a variable thickness in a cross-section. In some configurations, the proximal surface of the distal flexible cap has one of more of at least one of anchoring protrusions, nibs or ribs. The distal flexible cap can also be configured to have a shape selected from round, triangular, oval, ovoid, elliptical, square, and saucer. The flexible cap shape can have rounded edges. Additionally, the stem can be positioned on a proximal surface of the flexible cap at least one of centrally and non-centrally. A proximally accessible stem bore can also be provided. Additionally, a clip can be positionable within the proximal bore. The proximally accessible stem bore can also have at least one of internal threads along an interior surface, parallel walls along its length, non-parallel walls along its length, an undercut in the bore at a location along its length, and a bent bore along its length. Additionally, the bore can

be configured to extend from the proximal end of the device to the proximal end of the flexible cap. A wide variety of configurations for the stem are possible as will be appreciated. A few of the configurations include, for example, cross-sectional profile shapes selected from the group comprising square, triangular, arrowhead, trapezoidal, rectangular, J, Y, hook, and bulbous. The stem can further comprise a proximally positioned aperture therethrough, one or more exterior features adapted and configured to achieve anchoring the stem in vivo, one or more slots along at least a portion of its length parallel to a stem longitudinal axis beginning at its proximal end, a configuration which enables it to open away from the longitudinal axis from its proximal end, a proximal end adapted and configured to form a clasp, a socket, a breakable stem, a tearable stem, and/or at least one of the distal flexible cap and stem are in releasable communication with a tether. Additionally, a tether can be provided. The tether can be one or more of a wire, a spring, a thread, a ribbon, and a tube. Wire can at least be one of a bent wire, a curved wire, a wavy wire, and a helical wire. The delivery capsule can be further adapted and configured to comprise a valve, one or more proximally positioned detent features on an exterior surface of the cartridge body, one or more distally positioned undercuts, an exterior groove in the cartridge body, a one-way snap feature, an undercut central bore, and/or a central aperture adapted and configured to receive a plunger. Where the capsule receives a plunger it can further be configured to permit the plunger to move in a first axial direction and resist movement in a second axial direction different than the first direction. One or more collets can also be provided.

**[0008]** Yet another aspect of the disclosure is directed to a method of closing a wound or closing tissue. Suitable methods comprise: assembling a tissue closure system comprising a guide and seal assembly, a closure device delivery capsule, and an introducer; inserting the assembled would closure system percutaneously; centering a mammalian vessel with a distal tip of a tubular sheath of the introducer; and inserting a plunger into a proximal aperture in the guide and seal assembly; advancing the plunger through the guide and seal assembly into the closure device delivery capsule; engaging the closure device at the tip of the plunger; advancing the closure device into a tapered tip and reducing a profile of the closure device in at least one plane; advancing the closure device beyond the distal tip of the tubular sheath of the introducer and into the vessel; and withdrawing the system until a proximal surface of a face plate of the closure device comes in contact with an interior surface of the mammalian vessel; disengaging the closure device from the interior of the introducer. Additionally, at least one of the steps of pulling a tether connected to a proximal end of the closure device, and releasing the tether connected to the proximal end of the closure device.

**[0009]** Still other aspects are directed to a kit for a percutaneous procedure comprising a closure device delivery capsule housing a closure device; an introducer; a guide and seal assembly; and a plunger. The kit can further comprise one or more items selected from the group consisting of needles, hypo tubes, guidewires, electrode wires, intravenous wires, vascular introducers, catheters, laparoscopes, endoscopes, trocars, and cannulas, one or more compounds for delivery to a tissue, and/or one or more items selected from the group consisting of a pair of scissors, a scalpel, a swab, a syringe, a hemostat, a lubricant, a needle, a snare, an antiseptic, and an anesthetic. Suitable compounds include, for example, one or more of a sclerosing agent, an antibiotic, and an anti-inflammatory agent.

### INCORPORATION BY REFERENCE

[0010] All publications, patents, and patent applications mentioned in this specification are herein incorporated by reference to the same extent as if each individual publication, patent, or patent application was specifically and individually indicated to be incorporated by reference.

### BRIEF DESCRIPTION OF THE DRAWINGS

[0011] The novel features of the invention are set forth with particularity in the appended claims. A better understanding of the features and advantages of the present invention will be obtained by reference to the following detailed description that sets forth illustrative embodiments, in which the principles of the invention are used, and the accompanying drawings of which:

[0012] FIG. 1 shows a perspective view of an embodiment of a vessel closure system;

[0013] FIG. 2 shows a perspective view of an embodiment of a vascular closure clip in an open or pre-deployed configuration;

[0014] FIG. 3 shows a perspective view of the clip of FIG. 2 in a closed or deployed configuration;

[0015] FIG. 4 shows a side view of the clip of FIG. 2 in an open configuration;

[0016] FIG. 5 shows a side view of the clip of FIG. 2 in a closed configuration;

[0017] FIG. 6 shows a bottom view of the clip of FIG. 2 in a closed configuration;

[0018] FIG. 7 shows a perspective view of a deployment instrument preloaded with a vascular closure clip;

[0019] FIG. 8 shows a close-up view of the distal end of the deployment instrument of FIG. 7;

[0020] FIG. 9 shows a perspective view of an inner tubular member portion of the deployment instrument of FIG. 7;

[0021] FIG. 10 shows a side view of the inner tubular member of FIG. 9;

[0022] FIG. 11 shows a distal end view of the inner tubular member of FIG. 9;

[0023] FIG. 12 shows a perspective view of an outer tubular member portion of the deployment instrument of FIG. 7;

[0024] FIG. 13 shows a distal end view of the outer tubular member of FIG. 12;

[0025] FIG. 14 shows a side view of the outer tubular member of FIG. 12;

[0026] FIG. 15 shows a close-up side view of an intermediate portion of the outer tubular member of FIG. 12;

[0027] FIG. 16 shows another close-up side view of an intermediate portion of the outer tubular member of FIG. 12;

[0028] FIG. 17 shows a perspective view of a pressure element of the deployment instrument of FIG. 7;

[0029] FIG. 18 shows a perspective view of the deployment instrument of FIG. 7 loaded onto a vascular introducer that has been inserted into a patient's blood vessel;

[0030] FIG. 19 shows a perspective view of the deployment instrument of FIG. 7 which has been advanced over the vascular introducer until its distal end encounters the vessel wall;

[0031] FIG. 20 shows a close-up view of the deployment instrument of FIG. 19 showing the pressure element in an initial, relaxed position;

[0032] FIG. 21 shows a perspective view of the deployment instrument of FIG. 7 with the pressure element fully advanced;

[0033] FIG. 22 shows a close-up view of the deployment instrument of FIG. 21 showing the fully advanced pressure element;

5 [0034] FIG. 23 shows a close-up side view of the deployment instrument of FIG. 7 in a partially-deployed state showing the clip's tines penetrating the vessel wall;

[0035] FIG. 24 shows a perspective view of the deployment instrument of FIG. 7 in a partially-deployed state;

[0036] FIG. 25 shows a close-up view of the distal end of the deployment instrument of FIG. 24;

10 [0037] FIG. 26 shows a close-up bottom view of the proximal end of the deployment instrument of FIG. 24 showing the handle engaging the stop element;

[0038] FIG. 27 shows a side view of the proximal end of the deployment instrument of FIG. 24 showing the handle engaging the stop element;

[0039] FIG. 28 shows a side view of the deployment instrument of FIG. 24 in a partially deployed state after  
15 withdrawing the vascular introducer;

[0040] FIG. 29 shows a side view of the proximal end of the deployment instrument of FIG. 27 showing how the stop element can be overcome;

[0041] FIG. 30 shows a perspective view of the deployment instrument of FIG. 7 in a fully deployed configuration;

20 [0042] FIG. 31 shows a side view of the deployment instrument of FIG. 7 in a fully deployed configuration which shows the vascular closure clip closing the arteriotomy;

[0043] FIG. 32 shows a side view of the deployment instrument of FIG. 7 showing the deployment instrument being removed from the patient's body following deployment;

[0044] FIG. 33 shows a side view of a vascular closure procedure using a removable clip, showing the  
25 deployment instrument being advanced over the vascular introducer;

[0045] FIG. 34 shows a side view of the procedure of FIG. 33 showing the deployment instrument being removed after deploying the clip;

[0046] FIG. 35 shows a side view of the vascular closure procedure of FIG. 33 showing the vascular closure clip being removed from the patient's body following hemostasis;

30 [0047] FIG. 36 shows a perspective view of a clip loading mechanism;

[0048] FIG. 37 shows a perspective view of the clip loading mechanism of FIG. 36 fully inserted into the distal end of the deployment instrument;

[0049] FIG. 38 shows a perspective view of a pusher tool configured to mate with a vascular closure clip to fully advance the clip over the clip loading mechanism of FIG. 36 and onto the distal end of the deployment  
35 instrument;

[0050] FIG. 39 shows a perspective view of the pusher tool of FIG. 38 fully advancing the clip onto the distal end of the deployment instrument;

[0051] FIG. 40 shows a bottom view of a slidable tissue cutter;

[0052] FIG. 41 shows a perspective view of the slidable tissue cutter of FIG. 40;

[0053] FIG. 42 shows a bottom view of a frame which can constitute a first component of the slidable tissue cutter of FIG. 40;

5 [0054] FIG. 43 shows a distal end view of the frame of FIG. 42;

[0055] FIG. 44 shows a perspective view of a slidable tissue dilator;

[0056] FIG. 45 shows a distal end view of the slidable tissue dilator of FIG. 44;

[0057] FIG. 46 shows a side view of the slidable tissue dilator of FIG. 44;

[0058] FIG. 47A shows a perspective view of another embodiment of a vascular closure clip in an open  
10 configuration;

[0059] FIG. 47B shows a perspective view of the vascular closure clip of FIG. 47A in a closed configuration;

[0060] FIG. 47C shows a bottom view of the vascular closure clip of FIG. 47A in a closed configuration;

[0061] FIG. 47D shows a side view of the vascular closure clip of FIG. 47A in a closed configuration;

[0062] FIG. 48A shows a perspective view of another embodiment of a vascular closure clip in a closed  
15 configuration;

[0063] FIG. 48B shows a perspective view of the vascular closure clip of FIG. 48A in an open configuration;

[0064] FIG. 49A shows a perspective view of another embodiment of a vascular closure clip in an open  
configuration;

[0065] FIG. 49B shows a perspective view of the vascular closure clip of FIG. 49B in a closed configuration;

20 [0066] FIG. 50A shows a perspective view of another embodiment of a vascular closure clip in an open  
configuration;

[0067] FIG. 50B shows a perspective view of the vascular closure clip of FIG. 50A in a closed configuration;

[0068] FIG. 51A shows a perspective view of another embodiment of a vascular closure clip in an open  
configuration; FIG. 51B shows a perspective view of the vascular closure clip of FIG. 51A in a closed

25 configuration; FIG. 51C shows a side view of the vascular closure clip of FIG. 51A in an open configuration;

FIG. 51D shows a side view of the vascular closure clip of FIG. 51A in a closed configuration; FIG. 51E  
shows a top view of the vascular closure clip of FIG. 51A in a closed configuration;

[0069] FIG. 52 shows a circuit diagram of a circuit using direct resistive element heating to heat tissue  
surrounding the arteriotomy;

30 [0070] FIG. 53 shows a circuit diagram of a circuit using ohmic tissue heating to heat tissue surrounding the  
arteriotomy;

[0071] FIG. 54 shows a distal end view of another embodiment of an inner tubular member that can form one  
component of a deployment instrument;

[0072] FIG. 55 shows a proximal end view of the inner tubular member of FIG. 54;

35 [0073] FIG. 56A shows a perspective view another embodiment of a deployment instrument which can be  
used with a vascular closure plug; FIG. 56B shows a perspective view of the deployment instrument of

**FIG. 56A** preloaded with a vascular closure plug; **FIG. 56C** shows a perspective view of the deployment instrument of **FIG. 56A** after deploying the vascular closure plug;

**[0074]** **FIG. 57** shows a side view of the deployment instrument of **FIG. 56B** being advanced over a vascular introducer that has been inserted into a patient's blood vessel;

5 **[0075]** **FIG. 58** shows a side view of the deployment instrument of **FIG. 57** positioning the distal end of the vascular closure plug against the arteriotomy;

**[0076]** **FIG. 59** shows a side view of the deployment instrument of **FIG. 57** holding the plug against the arteriotomy after removing the vascular introducer;

10 **[0077]** **FIG. 60** shows a side view of the deployment instrument of **FIG. 57** showing the exposed portions of the plug beginning to swell;

**[0078]** **FIG. 61** shows a side view of a deployed plug as the deployment instrument of **FIG. 57** is removed;

**[0079]** **FIG. 62** shows a side view of the deployed plug of **FIG. 61** which is continuing to swell; and

**[0080]** **FIG. 63** shows a side view of the deployed plug of **FIG. 61** which has begun to be absorbed by the patient's body;

15 **[0081]** **FIGS. 64A-H** shows a closure system and various embodiments for locking mechanism; **FIGS. 64A-B** illustrate an exterior view of the system and a cross-section of the exterior view along the lines **B-B**, respective; **FIG. 64C** illustrates a close-up of the cross-section of the proximal section of the system shown in **Fig. 64b**; **FIG. 64D** illustrates a close-up of the distal end of the device; **FIGS. 64E-F** are close-ups of cross-sections of the proximal end of the device;

20 **[0082]** **FIGS. 65A-G** shows a delivery capsule with a cut away in **FIG. 65A**, an exterior side view **FIG. 65B**, a cross-section along the lines **C-C** in **FIG. 65C**, a view down the distal barrel end in **FIG. 65E**, a cross-section along the lines **F-F** in **FIG. 65F** and a cross-section with a directional indication for pressure in **FIG. 65G**;

**[0083]** **FIGS. 66A-D** shows a proximal cross-section of the delivery system illustrating embodiments of mechanisms of engaging a part of a portion of the delivery system with another part;

25 **[0084]** **FIGS. 67A-E** shows a plug deployment system in use with a currently available introducer with cross-sections of the proximal end (**FIG. 67D**) and expanded views (**FIG. 67C**);

**[0085]** **FIGS. 68A-B** shows an exterior view of plug deployment system in use with another currently available introducer;

30 **[0086]** **FIGS. 69A-B** shows an exterior view of another plug deployment system in use with yet another currently available introducer;

**[0087]** **FIGS 70A-G** shows a plug delivery capsule from an exterior view, a longitudinal cross-section along the lines **B-B** of **FIG. 70C**, a view down the distal end (**FIG. 70C**), and the delivery capsule collet from an exterior view (**FIG. 70D**), cross-sectional view along the lines **F-F** before machining **FIG. 70E** and after machining **FIG. 70F** to create the fingers or legs, and a view down the proximal barrel (**FIG. 70G**);

35 **[0088]** **FIGS. 71A-C** shows a collet cartridge insert from an exterior view (**FIG. 71A**), a cross-sectional view along the lines **B-B** (**FIG. 71B**) and a view down the barrel from the proximal end (**FIG. 71C**);

[0089] FIGS. 72A-E shows a capsule configuration from a side perspective view (FIG. 72A), a longitudinal cross-sectional view along the lines B-B (FIG. 72B), a view down the barrel from the distal end (FIG. 72C), a side view (FIG. 72D), and a view down the barrel from the proximal end (FIG. 72E);

[0090] FIGS. 73A-E shows another capsule configuration in a perspective shadow view (FIG. 73A), a longitudinal cross-sectional view along the lines B-B (FIG. 73B), a view down distal end (FIG. 73C), a cross-sectional view in shadow (FIG. 73D), and a view down the proximal end (FIG. 73E);

[0091] FIGS. 74A-D shows a plunger grip from a perspective view (FIG. 74A), a cross-sectional side view along the lines B-B (FIG. 74B), a side view (FIG. 74C) and a view down the distal end (FIG. 74D);

[0092] FIGS 75 A-C shows another plunger grip configuration with the plunger grip in a proximal shadow view (FIG. 75A), a cross-sectional side view along the lines B-B (FIG. 75B) and a view down the distal end (FIG. 75C);

[0093] FIGS. 76A-B shows a tether line configuration;

[0094] FIGS. 77A-B shows another tether line configuration;

[0095] FIGS. 78A-E shows a plunger tip from a perspective view (FIG. 78A), a longitudinal cross-section along the lines B-B (FIG. 78B), a view from the proximal end (FIG. 78C), a view from the distal end (FIG. 78D), and a cross-sectional view of the plunger tip and plunger (FIG. 78E);

[0096] FIGS. 79A-J shows two plug configuration, the first configuration from a perspective view (FIG. 79A), a top view from a distal end (FIG. 79B), a bottom view from a proximal end (FIG. 79C), a side view (FIG. 79D), and a longitudinal cross-sectional view along the lines E-E (FIG. 79E), and the second configuration from a perspective view (FIG. 79F), a top view from a distal end (FIG. 79G), a bottom view from a proximal end (FIG. 79H), a side view (FIG. 79I), and a longitudinal cross-sectional view along the lines E-E (FIG. 79J);

[0097] FIGS. 80A-C shows plug and locking configurations in operation with a stem portion of the plug in removable communication with the plate;

[0098] FIGS. 81A-N shows additional plug mating configurations employing wires, variably configured longitudinal apertures in the stem, hooks, clasps, perpendicular apertures through the stem;

[0099] FIGS. 82A-B shows releasable plug configurations which can be torn or separated along the stem;

[00100] FIGS. 83A-D shows tethered plug configurations which include a ball or radiopaque marker;

[00101] FIGS. 84A-D shows tethered plug configurations with a ball and socket connection;

[00102] FIGS. 85A-R shows plug stem variations having a wide variety of geometric shapes;

[00103] FIGS. 86A-E shows plug with petals design;

[00104] FIGS. 87A-B shows disc configurations for the face plate of the plugs;

[00105] FIGS. 88A-F shows alternative disc configurations for the face plate of the plugs;

[00106] FIGS. 89A-G shows disc configurations with ribs and nibs;

[00107] FIGS. 90A-E illustrates hemostatic plug capsule designs;

[00108] FIGS. 91A-I illustrates stem and capsule mating designs; and

[00109] FIGS. 92A-T illustrate the system component interactions and operations when deploying a vessel closure device using a system as disclosed.

[00110] FIGS. 93A-D show a plug with snap-action geometry.

[00111] FIGS. 94A-D show another example of a plug with snap-action geometry.

[00112] FIGS. 95A-C show a plug with self-intersecting geometry.

[00113] FIG. 96 shows vascular access closures.

5 [00114] FIGS. 97A-E show steps that may be used to deliver a removable vascular access closure with the additional ability to reaccess the existing puncture site.

**DETAILED DESCRIPTION OF THE INVENTION**

[00115] The following description provides examples of certain embodiments for purposes of illustration. The inventions as claimed should not be limited to these examples. Moreover, although the examples are provided  
 10 in the context of vessel closure, the invention also has broad application to other types of tissue closure. U.S. Patent No. 7,025,776 to Houser et al., the entirety of which is incorporated herein by reference, discloses a variety of additional vessel closure devices and methods with features that can be used in combination with or instead of features of the embodiments disclosed herein.

[00116] As will be appreciated by those skilled in the art, the components of the vessel closure systems  
 15 described herein can be sized to accommodate an introducer sized from 6French to 22French, and any size therein. Alternatively, the introducer be sized to be less than 6French, and/or greater than 22French. Ranges have been provided for purposes of illustration only and to facilitate a better understanding of the disclosure. Additional values, provided for illustration purposes only, are contained in Table 1.

**TABLE 1**

Component	System Size	Inner Diameter	Outer Diameter	Length	Additional Considerations
closure system	≤ 6F 16F 22F			0-50 mm > introducer length	OAL and typically dependent on introducer length
plunger grip	≤ 6F 16F 22F		2.0 - 35.0 mm 6 - 50 mm 7 - 75 mm	10 - 75 mm 15 - 75 mm 15 - 125 mm	ID typically a function of tube and capsule proximal end
deployment plunger	≤ 6F 16F 22F		0.5 - 3 mm 1 - 6 mm 2 - 8 mm	0-50 mm > introducer length	OAL and typically dependent on introducer length
plunger tube	≤ 6F 16F 22F	0.3 - 2.0 mm 0.3 - 5.5 mm 0.3 - 7.5 mm	0.5 - 3 mm 1 - 6 mm 2 - 8 mm	0-50 mm > introducer length	OAL and typically dependent on introducer length
plunger tip	≤ 6F 16F 22F		0.3 - 1.5 mm 0.3 - 4.5 mm 0.3 - 6.5 mm	1 - 10 mm 1 - 15 mm 1 - 25 mm	

Component	System Size	Inner Diameter	Outer Diameter	Length	Additional Considerations
delivery capsule collet	≤ 6F 16F 22F	0.48 min 0.80 min 1.80 mm	1.5 - 20 mm 1.5 - 35 mm 2.0 - 75 mm	2 - 15 mm 4 - 35 mm 5 - 50 mm	Nominally 0.02 mm, typically a smaller ID than the plunger tube OD
central lumen	≤ 6F 16F 22F				Per mfg specs, nominally the "French size" of the introducer i.e. 6F = 2mm
collet cartridge insert	≤ 6F 16F 22F	0.48 min 0.80 min 1.80 mm	2 - 20 mm 2 - 35 mm	2 - 25 mm 2 - 50 mm 3 - 75 mm	Nominally 0.5 mm larger ID than collet OD
capsule	≤ 6F 16F 22F	2 - 12 mm 3 - 15 mm 5 - 25 mm	3 - 35 mm 4 - 50 mm 6 - 75 mm	4 - 35 mm 4 - 75 mm 4 - 155 mm	
capsule exterior surface	≤ 6F 16F 22F	2 - 12 mm 3 - 15 mm 5 - 25 mm	3 - 35 mm 4 - 50 mm 6 - 75 mm	4 - 35 mm 4 - 75 mm 4 - 155 mm	
cartridge body	≤ 6F 16F 22F	2 - 12 mm 3 - 15 mm 5 - 25 mm	3 - 35 mm 4 - 50 mm 6 - 75 mm	4 - 35 mm 4 - 75 mm 4 - 155 mm	
detent	≤ 6F 16F 22F	6 - 35 mm 16 - 55 mm 22 - 75 mm		0.5 - 25 mm 0.5 - 55 mm 0.5 - 75 mm	ID typically not less than "French size" of system
tapered tip	≤ 6F  16F 22F				ID nominally equal to introducer lumen size OD tapers to fit introducer cap diameter
re-entrant nose	≤ 6F  16F 22F				length and OD are a function of particular dimensions of the introducer  ID tapers nominally to introducer lumen ID
hemostatic valve (on capsule)	≤ 6F 16F 22F	0 - 7 mm 0 - 17 mm 0 - 23 mm	depends on mfg depends on mfg depends on mfg	depends on mfg depends on mfg depends on mfg	fill closed to larger than introducer size, see mfg specs
side walls	≤ 6F	0.48 min	na/	2 - 25 mm	nominally equal to OD and length of collet cartridge insert

Component	System Size	Inner Diameter	Outer Diameter	Length	Additional Considerations
	16F 22F	0.80 mm 1.80 mm	n/a n/a	2 - 50 mm 3 - 75 mm	
base	≤ 6F 16F 22F				nominally equal to OD of collet cartridge insert

**I. Vessel Closure Systems**

[00117] Referring to FIG. 1, a vessel closure system 100 can generally include a vessel closure device such as clip 102 or plug and a deployment or advancement instrument 104. The plugs or closure devices can also be referred to as sealing devices, implants, vessel access closure devices, arteriotomy closure device, vascular closure devices, and tissue closure devices. As depicted, clip 102 is loaded onto a distal end 105 of deployment instrument 104. The deployment instrument 104 is slidably mounted to or advanced along and generally guided by a vascular introducer 108 or other tubular medical device such as a catheter which has been inserted into a blood vessel 18. In certain embodiments, a narrow opening in the skin initially created for the insertion of the vascular introducer 108 can be expanded or enlarged by a guided slidable tissue cutter 106 to form a percutaneous opening 12 sufficiently large to easily permit passage of the deployment instrument 104 into the body.

[00118] The deployment instrument 104 can be guided by a tube section 110 of vascular introducer 108 through the percutaneous opening 12 until it reaches arteriotomy site 14. The deployment instrument 104 is configured to deploy a vascular closure clip 102 to close the arteriotomy 14. The deployment instrument 104 can then be withdrawn.

**(a) Deployment Instrument**

[00119] A variety of deployment instruments are depicted and described herein. Persons of skill in the art will appreciate that the modifications to the designs disclosed can be performed without departing from the scope of the disclosure.

[00120] Turning now to FIG. 8 a more detailed view of the distal end 105 of a deployment instrument 104 from FIG. 1 is illustrated, which is configured to receive clip 102 and generally maintain it in an open configuration until deployed. In the illustrated embodiment, the tines 126a, 126b are substantially parallel with a central axis of the inner tubular member 154, and the distal ends 127a, 127b of the tines 126a, 126b are substantially aligned with the distal end 165 of the inner tubular member 154. In other embodiments, the distal ends 127a, 127b of the tines 126a, 126b can extend slightly beyond the distal end 165 of the inner tubular member 154. Alternatively, clip 102 can be located more proximally while the deployment instrument 104 is in its initial configuration with the distal ends 127a, 127b of the tines 126a, 126b being proximally spaced from the distal end 165 of the inner tubular member 154. As will be described in more detail below, the inner diameter of the base 120 of the clip 102 can be positioned close to or in contact with the outer diameter of the distal end 165 of the inner tubular member 154, and the outer diameter of the base 120 of the

clip *102* can be positioned close to or in contact with the inner diameter of the distal end *173* of the outer tubular member *156*. A radially inwardly directed restoring force exerted by the tines *126a*, *126b* in the open configuration increases the friction between the inner surfaces of the clip *102* and the outer surface of the inner tubular member *154*, generally preventing the clip *102* from readily sliding away from its position  
5 between the inner and outer tubular members *154*, *156*.

[00121] Distal end *173* of outer tubular member *156* can include an interior ledge or countersink *174* configured to receive and abut against the base *120* of clip *102*. As will be explained in more detail below, when the assembled deployment instrument *104* is advanced to the tissue closure site and the inner tubular member *154* is axially withdrawn in the proximal direction from the outer tubular member *156*, a distally directed reaction force is exerted by countersink *174* against the base *120* of the clip *102*, preventing the clip  
10 *102* from also moving in the proximal direction. When the distal end *165* of the inner tubular member *154* is moved in the proximal direction past the base *120* of the clip *102*, the contacting or adjacent relationship between the clip *102* and the inner and outer tubular members *154*, *156* is interrupted and the clip *102* is released from the deployment instrument *104*. In certain embodiments, the use of countersink *174* can permit  
15 the outer tubular member *156* to avoid contact with or otherwise to protect all or a portion of clip *102* during advancement prior to deployment. In other embodiments, countersink *174* can be omitted and the distal-most surface of outer tubular member *156* can be configured to contact base *120* to force off or otherwise permit removal of the clip *102* from the deployment instrument *104*.

[00122] FIGS. 9 - 11 are illustrations of an example of the inner tubular member *154* separated from the outer tubular member *156* before the configuration illustrated in FIGS. 7 - 8 is assembled. Inner tubular member  
20 *154* defines an inner lumen *166* which is configured to receive a tubular medical device such as a vascular introducer *108*. Elongate slot *162* allows at least a portion of the deployment instrument *104* to be tilted away from and axially separated from the proximal portion of the vascular introducer *108* by a medical professional without detaching the instrument *104* entirely from the tube section *110*. See, e.g., FIG. 1. This configuration  
25 permits the medical professional to position the deployment instrument *104* out of the way while the desired interventional or diagnostic procedure is performed. In the illustrated embodiment, axial grooves *160* run along the length of the outer surface of inner tubular member *154* and are configured to mate with axial protrusions *168* (see FIG. 13) formed on an inner surface of outer tubular member *156*. This mating configuration can prevent inner tubular member *154* from rotating relative to outer tubular member *156* and  
30 can help to align elongate slot *162* of inner tubular member *154* and elongate slot *170* of outer tubular member *156*.

[00123] The proximal end of inner tubular member *154* can include a handle *164* which may be gripped by the medical professional, for example, to withdraw inner tubular member *154* during deployment. The handle is generally configured for handling by a user and for enabling a user to achieve motion or operation of a distal  
35 end in response to the user's control of the handle. As illustrated, handle *164* can be generally circular with a flattened lower end to facilitate delatching of the stop mechanism during complete deployment as explained below. Other shapes and configurations can also be used. The upper portion of handle *164* includes a cut-out

portion **350** which is aligned with and merges with elongate slot **162**. Lower portion of handle **164** includes a recess **169** to accommodate tab **172** of the outer tubular member **156**. The distal end of handle **164** includes distal faces **354** which can be substantially flat. Faces **354** are configured to abut the proximal-most edge of the tube section of outer tubular member **156** to prevent over-insertion of inner tubular member **154** into outer tubular member **156**. Proximal faces **167** of handle **164** can be substantially flat and are configured to abut stops **175** on tab **172** during partial deployment. Lower portion of the handle **164** can include angled surfaces **352**.

**[00124]** FIGS. **12 - 16** illustrate an example of an outer tubular member **156** separated from the inner tubular member **154** before the configuration illustrated in FIGS. **7 - 8** is assembled. Outer tubular member **156** defines an inner lumen **171** configured to receive inner tubular member **154**. An elongate slot **170** runs along a length of outer tubular member **156** and provides access to the interior of inner lumen **171**. Elongate slot **170** of outer tubular member **156** is configured to align with elongate slot **162** of inner tubular member **154**. Distal end **173** of outer tubular member **156** can include one or more slots **176** to provide side access to clip **102** while deployment instrument **104** is in its initial configuration.

**[00125]** A securing or movement-limiting structure such as tab **172** extends from a proximal end of outer tubular member **156**. Tab **172** includes stop surfaces **175** configured to abut the proximal faces **167** on handle **164** during partial deployment as explained in more detail below. Tab **172** can include two tapered arms **181** surrounding a window portion **177** to facilitate assembly of the deployment instrument **104** as explained further below. Tab **172** can also include a recessed, weakened, or hinge portion **186** to facilitate bending. In certain embodiments, tab **172** can be relatively rigid with the exception of weakened portion **186**. In certain embodiments, bending of tab **172** can be configured to occur substantially at weakened portion **186**. In certain embodiments, tab **172** can be relatively long. For example, tab **172** can be at least about 20 mm. A long tab **172** can facilitate handling by the medical professional. A long tab **172** can also increase the leverage applied by the medical professional to effectuate bending.

**[00126]** The deployment instrument can include a pressure sensitive structure which can comprise, in one example, pressure tapers **178** formed on an outer surface of outer tubular member **156** and flexible tabs **188** of pressure element **158**. Outer tubular member **156** can also include a pressure sensitive structure such as an axial protrusion **185** extending from a proximally-located outer surface. As illustrated, axial protrusion **185** can be located in a substantially diametrically opposite position from elongate slot **170**, although other configurations are possible. A ramp or one-way tapered lock **184** extends from axial protrusion **185**. A stop, **182** which can be generally annular in shape, extends from an outer surface of outer tubular member **156**. The outer surface of outer tubular member **156** also includes pressure tapers **178**. Pressure tapers **178** can terminate in substantially flat surfaces **180**. Surfaces **180** can be adjacent to and in contact with annular stop **182**. As illustrated in FIG. **16**, outer tubular member **156** can include two pressure tapers **178** located in a substantially diametrically opposite position from one another on the generally circular outer tubular member **156**. Also as illustrated, pressure tapers **178** can be positioned at approximately equal circumferential distances from elongate slot **170** and axial protrusion **185**. Other configurations are possible.

[00127] FIG. 17 provides a detailed illustration of a pressure element 158, which in some embodiments can be a generally ring-shaped element configured to be received on an outer surface of outer tubular member 156. In certain embodiments, as illustrated, pressure element 158 can be a separate element from outer tubular member 156. In other embodiments, pressure element 158 can be integrally formed with outer tubular member 156. As described in more detail below, pressure element 158 can be used to confirm that the medical professional is applying generally sufficient but not excessive pressure to safely begin deployment of the clip 102. Pressure element 158 can include a cut-out portion 105 aligned with elongate slots 162, 170 of the inner and outer tubular members 156, 154. Recess 190 can be configured to mate with axial protrusion 185 of outer tubular member 156 to keep the pressure element 158 properly aligned. An inner surface of pressure element 158 includes one or more flexible tabs 188. Flexible tabs 188 are configured to align with, and be advanced over, pressure tapers 178 of outer tubular member 156.

[00128] During assembly of deployment instrument 104, pressure element 158 can be advanced over the proximal end of outer tubular member 156 and over one-way tapered lock 184. Recessed portion 190 and/or lock 184 can be configured to flex or temporarily deform sufficiently to accommodate this procedure.

Alternatively, lock 184 or other locking means can be formed on, or secured to, outer tubular member 156 after positioning of pressure element 158. Tapered lock 184 prevents pressure element 158 from moving too far in a proximal direction with respect to outer tubular member 156. Inner tubular member 154 can then be inserted into the inner lumen 171 of outer tubular member 156 from the outer tubular member's proximal end. As the inner tubular member 154 is inserted into outer tubular member 156, inner surfaces 183 (see FIG. 11) of the lower portion of handle 164 adjacent to recess 169 begin to come into contact with tapered arms 181 of tab 172. The continued advancement of inner tubular member 154 distally causes surfaces 183 to apply an inwardly-directed force to arms 181. Window 177 permits arms 181 to resiliency flex inwardly until handle 164 has been advanced distally of stops 175. Inner tubular member 154 can then be advanced further until distal faces of handle 354 contact the proximal-most edge of the tube section of outer tubular member 156.

[00129] In another example of a deployment instrument forming part of a closure system or kit, a vessel closure system 600 is shown in FIGS. 64A-E. The vessel closure system 600 is adapted and configured to further provide three sections in communication with each other: a plunger 610, a capsule 630 and an introducer 650. The plunger 610 further includes a deployment plunger 612, and a guide and seal assembly 614. The deployment plunger 612 is a rod, such as a cylindrical or substantially cylindrical rod, configured to be housed within an aperture formed in the guide and seal assembly 614. The plunger 612 is configured such that it is capable of a movement in at least one direction along a central axis A. The plunger can terminate in a plunger tip 620 which may, in some configurations, be removable.

[00130] The closure device capsule 630 engages the plunger at a proximal end 70 and an introducer at a distal end 80. The capsule 630 includes a deployment cartridge body 632, and a compressible section 634. In some configurations, the capsule 630 is adapted and configured to snap fit within at least a portion of the introducer cap.

[00131] The introducer 650 further is adapted to receive a part of the capsule 630. A re-entrant nose 646 of the capsule 630 is positioned to align within an aperture of an introducer bore to minimize cocking of the closure device 670 during deployment. A central aperture 656 is provided through which the clip, plug or closure device 670 contained in the capsule 630 can travel during deployment. In this configuration a hemostasis valve 652 is provided on the introducer which maintains the closure device 670 in position within the capsule during delivery.

[00132] Once the introducer, capsule 630 and plunger have been assembled, the components will not separate during use. This feature prevents inadvertent disassembly once the clip, plug or closure device 670 is deployed in the vessel. For example, if the entire deployment assembly and introducer are not withdrawn as a single unit, the clip, plug or closure device 670 could be stripped off the plunger. This could result in the clip, plug or closure device 670 being deployed in the vessel without properly seating at the arteriotomy site. As shown in FIG. 64C, the capsule 630 snap fits over the introducer 650 at its proximal end and the capsule 630 snap fits within the introducer at its proximal end. Additional flanges 675 can be provided on the distal end 80 of the cap 616 or arms extending from the plunger 610 which fit within a detent 636 provided on the exterior surface 631 of the capsule 630 when the plunger 610 is fully positioned on the capsule 630.

[00133] Each component can be configured to provide a one-way snap feature, as shown in more detail in FIGS. 64E-H. In FIGS. 64E-F the plunger grip 610 has been snapped onto the capsule 630 and the system is provided with internal locking feature shown are characterized in that the proximal end 70 of the introducer 650 has a cap 656 or arms that extend radially from the axis A and then curve and extend along an axis parallel to, or substantially parallel, the axis A to engage and mate with an exterior surface of the distal end 80 of the capsule 630. The capsule 630 features a tapered tip 636 at its distal end 80 which can further be provided with an undercut that is configured to fit within an interior recess of the introducer.

[00134] An example of an external lock feature is shown in more detail in FIG. 64G-H. As with the previous illustration, the plunger grip 610 has been snapped onto the capsule 630. Where external locking features are provided, the proximal end of the introducer 650 is has a flange into which the capsule 630 fits and which further includes fingers 660 that fit within a groove 642 formed on an exterior surface 631 of the capsule 630.

[00135] Tissue clips and plugs, described in more detail below, can be deployed using the system by providing the clip, plug or closure device 670 within a capsule 630 as shown, for example, in FIGS. 65A-G. The capsule 630 has a tubular exterior surface 631 with a first diameter at a proximal end 70 and a smaller diameter at a distal end 80. As will be appreciated by those skilled in the art, the tubular capsule can take a variety of cross-sectional configurations including circular, oval, polygon, D shape, etc. For purposes of illustration, dimensions are provided for a circular cross-sectional shape in order to provide a context for the sizes and volumes involved. Additionally, the sizes may change as a result of the size of the introducers used. Persons of skill in the art will appreciate that introducers can vary from 8 French to 20French (and values therein). Thus dimensions would likely be proportional to the French size of the introducer. Thus, for example, a typical diameter of the first diameter could be from about 4mm to 25mm, more preferably about 8mm, or any value therein to about 100<sup>th</sup> of a mm. Typical diameters of the second diameter range from about 1mm to

about 3mm, more preferably about 2mm, or any value therein to about 100<sup>th</sup> of a mm. The overall length of the capsule ranges from about 12mm to about 50mm or up to 100mm, more preferably about 35mm, or any value therein to about the 100<sup>th</sup> of a mm. The capsule **630** includes a clear tubular section **640** approximately mid-length through the presence of the clip, plug or closure device can be observed through which fluid flow can be observed as the clip, plug or closure device **670** contained within the capsule **630** is deployed. As shown in the cross-section along the lengthwise axis *A*, the capsule body **632** includes a proximal end **70**, a distal end **80** and a mid-section. An aperture **638**, **638'** is provided in both the proximal body section and the distal body section. A valve **648** can be provided as shown. The closure device **670** is positioned within the interior of the capsule **630** at a position where the capsule body **632** is configured such that a user can see the clip, plug or closure device **670** within the capsule body **632**. The re-entrant nose **646** the plunger grip **610** has been snapped onto the capsule **630** and the system is provided with internal locking feature shown are characterized in that the proximal end **70** of the introducer **650** can be tapered along its length such that its diameter at its proximal end **70** and its distal end **80** are not substantially the same. Additionally, the elongated aperture **638'** within the nose **646** can also change in diameter along its length. The tapered end tip **646** at the distal end is configured to dilate the hemostatic valve **652** within the introducer **650** such that the valve can at least temporarily be opened, allowing the clip, plug or closure device **670** to be advanced through the valve without potentially damaging the clip, plug or closure device **670**, or dislodging the clip, plug, closure device from the distal end of the plunger **612**. By altering the cross-section of the elongated aperture within the nose **654** through which the clip, plug or closure device **670** travels during deployment, the clip, plug or closure device **670** can thereby be manipulated to achieve a reduced profile as the clip, plug or closure device **670** is advanced forward. The see-through chamber allows a fluid, such as blood, to flow, confirming that the proper location of the introducer sheath has been achieved. The capsule **630** may further be configured to include a guide for the insertion of a tool to contact and advance the clip, plug or closure device **670**. In the configuration depicted here, the legs of the clip, plug or closure device **670** are positioned to sit on an edge of the bore on the distal section.

[00136] Turning to FIGS. 66A-D, additional configurations of capsule **630** and plunger assemblies configured to prevent disassembly are provided. The configurations illustrated are adapted and configured to prevent inadvertent separation of a deployment assembly from an introducer once the clip, plug or closure device is fully extended into the vessel. Some configurations can be adapted and configured to enable a deliberate override by a physician, if necessary. As with the previous configuration, the vessel closure system **600** is adapted and configured to further provide three sections in communication with each other: a plunger **610**, a capsule **630** and an introducer **650**. The plunger **610** further includes a deployment plunger **612**, and a guide and seal assembly **614**. The deployment plunger **612** is a rod, such as a cylindrical or substantially cylindrical rod, configured to be housed within an aperture formed in the guide and seal assembly **614**. The plunger **612** is configured such that it is capable of a movement along a central axis *A* in a first direction and a second direction. The plunger **610** fits over and snaps onto the proximal end **70** of the capsule **630**. Alternatively, an internal lock feature can be provided wherein a male section of the plunger **610** slides into a mating female

recess in the proximal end of the capsule **630** and locks in place as shown in **FIG. 66D**. In some configurations, a separate seal is not provided. Rather hemostasis is achieved by the closure device itself as it seals within the capsule. Thus, provision of a separate seal in any of these configurations is optional.

[00137] An additional aspect of the deployment system is that it can be used with a variety of commercially available introducer systems, such as those available from Cordis (**FIGS. 67** and **69**), and St. Jude Medical (**FIG. 68**). As shown in **FIGS. 67A-E, 68A-B** and **69A-B** each of the systems **600** includes a plunger **610**, a delivery capsule **630** in combination with a plunger **612**, a plunger tube **618**, a collet cartridge insert **623**, a delivery cap collet **621**, a bioabsorbable closure device **670**, a tether **662**, a tether drag element **664**. A plunger tip **613** can also be provided as shown in **FIGS. 68** and **69**. The introducers depicted herein typically range from about 120 mm to about 170 mm in length, or any length therein to the 100<sup>th</sup> of a mm. The plunger tubes typically are from 15mm to 50mm longer than the length of the commercially available introducers for which they are configured to mate, e.g., a deployment system configured to work with a 120mm introducer would have a plunger from about 135mm to about 170 mm in length, or any length therein and have an inner diameter (for 6 French introducers) of from about 1.0 mm to about 2.4mm. The system may be configured to enable simple and easy, non-surgical closure of hemodialysis vascular access sites (including, for example, fistulae and/or grafts) that will no longer be used because of occlusion or other reason.

[00138] A suitable configuration for the delivery capsule **630** is shown in further detail in **FIGS. 70A-F**. The delivery capsule **630** has an outer diameter from about 4mm to 12mm on its distal end **80** and from about 3mm to about 11mm on its proximal end **70** or any size therein to about the 100<sup>th</sup> of a mm. Where the devices are volume manufactured, the distal tip and the capsule can be configured as a single component. The proximal end **70** has an aperture into which the guide assembly fits (as shown above in **FIG. 64**) and an aperture therethrough through which the deployment plunger can travel as it pushes the closure device to the delivery site. The distal end **80** has a smaller outer diameter to facilitate engaging the introducer (which fits around the exterior surface **631** of the capsule **630** until it reaches the wall. From **FIG. 70C**, which is a view down the barrel of the capsule **630** from the distal end **80**, the central aperture **644** can be seen and the bottom face **649'** formed from the counterbore which is characterized by side walls and a base surface. The delivery capsule collet **621** shown in **FIGS. 70D-E** has a first diameter ranges from about 3mm to about 4mm, or any size therein to about the 100<sup>th</sup> of a mm and the second diameter ranges from about 2.7mm to about 3.0mm, or any size therein to about the 100<sup>th</sup> of a mm. An inner diameter of the aperture ranges from about 1.5mm to about 1.9mm at its proximal end and about 1.3mm to about 1.7mm at its distal end, or any size therein to about the 100<sup>th</sup> of a mm. From **FIG. 70F**, the exterior taper of the outer surface of the collet **621** from a proximal end (wider) to a distal end (narrower) has a value of from about 0.4° to about 8°, or more preferably about 5°, or any value therein.

[00139] The collet cartridge insert **623** is shown in **FIGS. 71A-C**. The collet cartridge insert is a slotted cylindrical clamp that is inserted into the tapered interior of the delivery capsule to hold the capsule. The collet cartridge insert has a cylindrical profile with an aperture therethrough along an axis **A**. The aperture has a tapered dimension as illustrated in **FIG. 71B**. **FIG. 71C** is an end-view of the collet cartridge insert from a

distal end **80**. The collet typically has a first outer diameter at a proximal end **70** and a second outer diameter at a distal end **80**. The first diameter ranges from about 4.4mm to about 5.0mm, or any size therein to about the 100<sup>th</sup> of a mm and the second diameter ranges from about 4.7mm to about 5.0mm, or any size therein to about the 100<sup>th</sup> of a mm. An inner diameter of the aperture ranges from about 3.3mm to about 3.9mm at its proximal end and about 1.5mm to about 1.8mm at its distal end, or any size therein to about the 100<sup>th</sup> of a mm. The exterior taper of the interior aperture of the collet cartridge insert from a proximal end (wider) to a distal end (narrower) has a value of from about 0.4° to about 8°, or more preferably about 5°, or any value therein.

**[00140]** The delivery capsule **630** distal tip **654** is shown in more detail in **FIGS. 72A-E**. The delivery capsule **630** distal tip **654** has a stem with an aperture **636** therethrough. The stems can also be referred to as a core, column, vertical section, mid-section, center, post or shaft without departing from the scope of the disclosure. The aperture ranges in diameter from about 3.8mm to about 4.2mm at its proximal end, more preferably about 4.02 mm, or any value therein to about the 100<sup>th</sup> of a mm and then tapers down to a diameter of about 2.4 mm to about 2.6 mm, or more preferably about 2.51 mm, or any value therein to about the 100<sup>th</sup> of a mm along its tapered tip **638**. The length of the distal tip ranges from about 4.0mm to about 25.0mm, more preferably about 18mm, or any length therein to about 100<sup>th</sup> of a mm. In some configurations lengths greater than 35mm may be appropriate. The outer diameter of the delivery capsule distal tip is about 3.0mm to about 4.0mm, more preferably 3.2mm, or any value therein to about the 100<sup>th</sup> of a mm. Outer diameters can be, in some instances up to 35mm or more. The outer diameter of the widest section is about from 4.5mm to about 10.0mm, more preferably about 5.7mm, or any value therein to about 100<sup>th</sup> of a mm. In some configurations, the widest section can be up to 35mm or greater. The proximal section has an outer diameter of about 4.5mm to about 10.0mm, more preferably about 5.7mm, or any value therein to about the 100<sup>th</sup> of a mm. An internal tapered section **634** is located near a proximal end **70**. The distal tip has an intermediate body with a radius larger than the radius of the neck. A proximal section is provided which has a radius larger than the distal tip but less than the intermediate body. The proximal transparent module section of the delivery capsule **630** is shown in more detail in **FIGS. 73A-E**. The transparent section has body with an aperture **637** therethrough. The body is configured to provide an outer diameter at its proximal end **70** sized to engage the distal end **80** of the plunger and an outer diameter at its distal end **80** sized to engage the proximal end **70** of the delivery mechanism. As illustrated, the outer diameter of the proximal end **70** is larger than the diameter of an intermediate section, but smaller than a diameter of the distal section. The aperture at the distal end **80** is large enough to enable the proximal end **70** of the delivery mechanism to fit within a recess and abut against a distally facing surface. The proximal end **70** of the aperture has a diameter that flares as it reaches the proximal end **70** of the module.

**[00141]** The capsule contains the sealing element or vessel closure device and protects the device from damage during the delivery process. As a result of the configuration of the capsule, the capsule also initiates reduction of the cross-sectional diameter of the vessel closure device prior to the vessel closure device entering the introducer. The capsule achieves a reduction in the cross-sectional diameter of the vessel closure device by, for example, deflecting a radially extending section of the vessel closure device. The capsule also

facilitates in confirming that the introducer sheath is positioned within the target vessel, by the presence of blood viewable in the capsule.

[00142] The plunger grip **610** is shown in **FIGS. 74A-D**. The plunger grip **610** is configured to provide a variable external surface facilitating engagement by a user. The proximal end **70** has a knob-like shape which tapers into a narrower neck before widening at its distal end **80**. A central lumen **622** is provided along an axis **a**, through a portion of its length, terminating prior to the proximal end **70**. A perpendicular aperture can be provided near the distal end **80** which is in communication with the central lumen. The perpendicular aperture can, for example, be a threaded hole for use with a set screw to allow adjustment of the overall length of the plunger. The length of the plunger grip is about 12mm to about 45mm, or more preferably 25 mm, or any value therein to the 100<sup>th</sup> of a mm. The outer diameter of the plunger grip ranges from about 3.0mm to about 12mm along its length, more preferably about 10mm at its widest section and about 6mm at its narrowest section, or any value therein to about the 100<sup>th</sup> of a mm. The concave central portion of the plunger, particularly has varying outer diameter along its length over a range of from about 5mm of the length to about 20 mm of the length, or more preferably 7 mm to about 15 mm, or any value therein to about the 100<sup>th</sup> of a mm. Although this feature is optional, it improves the physician's grasp on the proximal end. The central lumen is for engagement with the plunger rod or tube.

[00143] An alternate embodiment of a plunger grip is shown in **FIGS. 75A-C**. As depicted the plunger grip **610** does not have a concave section along its length. The plunger grip has a central lumen **622** having a first inner diameter and a second inner diameter, and a length of about 10mm to about 35mm, more preferably about 16mm, or any value therein to about the 100<sup>th</sup> of a mm. The first inner diameter of the lumen is from about 6.3mm to about 7.7 mm, more preferably about 7 mm, while the outer diameter of the plunger grip is from about 7.6mm to about 8.9mm, more preferably about 8mm, or any value therein to about the 100<sup>th</sup> of a mm. The second inner diameter is from about 1.2mm to about 1.8mm, more preferably 1.6mm, or any value therebetween to about the 100<sup>th</sup> of a mm. The length of the lumen of the first diameter section ranges from about 5.0mm to about 7.6mm, more preferably about 6.4mm, or any value therein to about the 100<sup>th</sup> of a mm, while the length of the lumen of the second diameter section ranges from about 7.6mm to about 11.4mm, more preferably about 9.4mm, or any value therein to about the 100<sup>th</sup> of a mm.

[00144] In some configurations of the system, tether lines **672** can be employed. Tethers can also be referred to as leashes, temporary or removable plug attachment mechanisms, suture lines, threads, wires, lines, containment members, containment elements, safety elements and capture elements without departing from the scope of the disclosure. The tether may be bioabsorbable, biodegradable, or otherwise break down in the body. Suitable tether line configurations are shown in **FIGS. 76A-B** and **77A-B**. The tether line **672** can be a continuous loop as shown in **FIG. 76A** or can be a wire forming a tether **674** as shown in **FIGS. 81A-D**. In some configurations, such as those depicted in **FIGS. 68** and **69**, a plunger tip **662** is employed without a tether line. A suitable configuration of a plunger tip is illustrated in **FIGS. 78A-E**. The plunger tip **662** has a round distal **80** tip and a tapered proximal **70** end adapted to snap fit within a suitable mating recess **676** as shown in **FIG. 79E** in the proximal end of the vascular closure. **FIGS. 68, 69** and **78E** show the plunger tip within the

plunger stem. The overall length of the plunger tip is, for example, from about 7.6mm to about 11.4mm, more preferably about 9.5mm, or any length therein to about the 100<sup>th</sup> of a mm. The proximal end has a trapezoidal cross-section **664** with a first width of about 1.02mm to about 1.27mm, more preferably 1.14mm or any diameter therein to about the 100<sup>th</sup> mm. Over a length of about 0.76mm to about 1.02mm, more preferably about 0.89mm, the trapezoidal cross-section widens to a diameter of about 1.02mm to about 1.27mm, more preferably 1.14mm, or any diameter therein to about the 100<sup>th</sup> mm. An intermediate narrowed neck section **666** follows having a diameter similar to the proximal end of the trapezoidal section and a length of about 0.76 mm to about 1.02mm, more preferably about 0.89mm. The main body **668** of the plunger tip has a diameter of about 1.77mm to about 2.29mm, more preferably about 1.98mm, or any diameter therein to about 100<sup>th</sup> of a mm. From the view looking at the plug from a proximal end shown in **FIG. 78C**, the three varying diameters of the proximal end of the trapezoidal cross-section, the wider diameter of the trapezoidal section and the main body are visible. The diameter of the intermediate narrowed neck is not visible. After the main body **668**, a stem section **665** narrows from a proximal end towards a distal end along a length of from about 3.05mm to about 4.32mm, more preferably about 4.04mm, or any value therein to about the 100<sup>th</sup> of a mm. The stem section **665** ends distally with the formation of a bulbous end **667**. The bulbous end has a diameter of about 1.02mm to about 1.17mm, more preferably about 1.14mm, or any length therein to about the 100<sup>th</sup> of a mm. As viewed from the distal end, shown in **FIG. 78D**, the diameter of the bulbous end is visible and the main body. As will be appreciated from reviewing **FIG. 78E**, the plunger fits within an aperture in the distal end of the plunger stem **618**, which is connected to the handle at its proximal end.

**(b) Tissue Clips, Plugs and Other Closure Devices**

[00145] Tissue clips, plugs and other closure devices disclosed herein are disclosed in the context of delivery into a mammalian body for purposes of closing, for example, an artery. However, as will be appreciated by those skilled in the art, other applications are possible. For example, the clips, plugs and other closure devices could be sized such that they do not require delivery by a delivery system but rather are delivered in the field in the context of a trauma - such as a knife wound or gunshot wound - as an alternative to compression to stop bleeding. A variety of elements can be used in conjunction with the closure devices either on an exterior surface or an interior surface including, but not limited to, edges, ridges, flanges, wings, petals, radially extending members, and horizontal protrusion. Any discussion of any such elements, may also refer to other elements disclosed.

[00146] **FIG. 2** is a perspective view of an embodiment of a clip **102** in a pre-deployed or open configuration. Clip **102** can include a base portion **120**. Base portion **120** can be generally or completely annular, forming a partial or complete circle. In some embodiments, a base portion **120** with a continuous or substantially continuous circle along its upper edge as illustrated can provide increased strength and resistance to contortion or bending in either or both of the open and closed configurations. A generally circular base portion **120** can allow the tines **126a-b** to move or bend during the transition between the open and closed configurations while generally resisting a substantial change in shape or orientation of the base portion **120**. The height **135** of the base portion **120** can be selected to achieve a desired amount of stiffness or flexibility.

[00147] Fingers *122* and *124* can be configurable to extend from base portion *120* and support a plurality of tissue-engaging elements such as tines *126a-b*. In some embodiments, as illustrated, the fingers *122* and *124* can be positioned in a substantially opposing arrangement, for example wherein finger *122* is positioned in a substantially diametrically opposite location on the generally circular base *120* from finger *124*. As explained  
5 below, many other positions and configurations can be used.

[00148] In the illustrated example of FIG. 2, each finger *122*, *124* includes three tines: one central tine *126a* and two outer tines *126b*. The outer tines *126b* can be substantially the same length *132* from the respective tips *127b* to the respective junctures with the forward surface *134* of each finger *122*, *124*. In some  
10 embodiments, the forward surface *134* can be substantially perpendicular to the tines *126a*, *126b* and substantially parallel with the plane of the base *120* in the open configuration. Surfaces *134* can generally act as substantially blunt stops to prevent over-insertion of clip *102* into the vessel wall *16*. In some  
15 embodiments, the length *133* of the central tines *126a* can be slightly greater than the length *132* of the outer tines *126b*. This length differential can assist in producing an increased leverage and an increased force along a central line generally bisecting the base *120* between the two opposing central tines *126a* to help pull  
20 generally opposing sides of a tissue slit opening together.

[00149] In some embodiments, the lengths *132*, *133* can be selected so that the tines *126a*, *126b* pierce but do not completely penetrate through a vessel wall *16* of average thickness into the interior region of the vessel *18*. For example, the length *132* may be greater than or equal to about 1 mm, and/or the length *132* may be less  
25 than or equal to about 4 mm, and the length *133* may be greater than or equal to about 1 mm, and/or the length *133* may be less than or equal to about 5 mm. In some embodiments, the length *132* is about 3 mm, and the length *133* is about 3 mm. In other embodiments, the tines *126a*, *126b* can be configured to penetrate the vessel wall, but generally not long enough to contact or penetrate the vessel wall *17* on the opposite side of the vessel *18*. The lengths of the tines *126a*, *126b* are generally greater than the height *135* of the base portion  
30 *120*. In the illustrated embodiment, fingers *122* and *124* are generally symmetrical about a central axis. In other embodiments, the fingers *122*, *124* can be asymmetrical or include a different number or configuration of tissue-engaging elements.

[00150] Fingers *122*, *124* can include one or more bend-facilitating regions *125*, such as narrowed regions, indentations, articulating joints, or window portions as illustrated. The size, shape, and placement of the bend-facilitating regions *125* can be adjusted to assist in achieving a desired amount of closure force for the  
35 clip *102*. As illustrated, the contours of the bend-facilitating regions *125* can be generally smooth to avoid additional trauma to the vessel wall. In some embodiments, an upper edge *129* of a bend-facilitating region *125* can be positioned in general alignment with a lower edge *131* of the base portion *120* to maintain a desired height *135* of the base portion *120*. As illustrated, the width of the bend-facilitating region can be smaller than the height *135* of the base portion *120*.

[00151] FIG. 3 shows a perspective view of clip *102* in a closed or deployed configuration. Clip *102* is preferably biased into a closed configuration. As shown in FIGS. 1 and 2, clip *102* can be temporarily maintained in an open or pre-deployed state by deployment instrument *104* until it is deployed and returns to

substantially the same configuration illustrated in FIG. 3. Clip *102* can be configured to automatically close upon deployment to close the arteriotomy. In certain embodiments, the closing of clip *102* can be accomplished substantially via changes in flexion regions *400*. In some embodiments, the dimensions, shape, and/or orientation of other portions of clip *102* can remain substantially unchanged between the pre-deployed and deployed states.

[00152] FIG. 4 is a side view of clip *102* in an open configuration. The respective heights *135*, *136*, *401*, of the base portion *120*, the support portion *141*, and the bend-facilitating region *125*, can have many different values, depending on the particular application of the clip *102* and other design preferences. Moreover, these heights *135*, *136*, *401* can be constant or can vary in some embodiments. By way of example, the height *135* of the base portion *120* may be greater than or equal to about 0.5 mm and/or may be less than or equal to about 2 mm; the height *136* of the support portion *141* may be greater than or equal to about 0.5 mm and/or may be less than or equal to about 4 mm; and the height *401* of the bend-facilitating region *125* may be greater than or equal to about 0.2 mm and/or may be less than or equal to about 2 mm or any size therein to about the 100<sup>th</sup> of a mm. In some embodiments, the height *135* of the base portion *120* is about 0.5 mm, 0.6 mm, 0.7 mm, 0.8 mm, 0.9 mm, 1.0 mm, 1.1 mm, 1.2 mm, 1.3 mm, 1.4 mm, 1.5 mm, 1.6 mm, 1.7 mm, 1.8 mm, 1.9 mm or 2.0 mm. In some embodiments, the height *136* of the support portion *141* is about 0.5 mm, 0.6 mm, 0.7 mm, 0.8 mm, 0.9 mm, 1.0 mm, 1.1 mm, 1.2 mm, 1.3 mm, 1.4 mm, 1.5 mm, 1.6 mm, 1.7 mm, 1.8 mm, 1.9 mm, 2.0 mm, 2.1 mm, 2.2 mm, 2.3 mm, 2.4 mm, 2.5 mm, 2.6 mm, 2.7 mm, 2.8 mm, 2.9 mm, 3.0 mm, 3.1 mm, 3.2 mm, 3.3 mm, 3.4 mm, 3.5 mm, 3.6 mm, 3.7 mm, 3.8 mm, 3.9 mm, or 4.0 mm or any size therein to about the 100<sup>th</sup> of a mm. In some embodiments, the height *401* of the bend-facilitating region *125* is about 0.2 mm, 0.3 mm, 0.4 mm, 0.5 mm, 0.6 mm, 0.7 mm, 0.8 mm, 0.9 mm, 1.0 mm, 1.1 mm, 1.2 mm, 1.3 mm, 1.4 mm, 1.5 mm, 1.6 mm, 1.7 mm, 1.8 mm, 1.9 mm or 2.0 mm or any size therein to about a 100<sup>th</sup> of a mm. In some embodiments, the height *135* is about 1 mm, the height *136* is about 2 mm, and the height *401* is about 0.8 mm. Other suitable heights can also be used.

[00153] As illustrated in FIGS. 2-4, the height *136* of the support portions *141* of fingers *122* and *124* can be less than the length *133* of central tines *126a* (for example, less than about 80%). This can permit the base portion *120* of the clip *102* to be positioned relatively close to the outer surface of the vessel wall *16* when the clip *102* is attached. In some embodiments, the support portions *141* can have different sizes or may be eliminated (e.g., with the tines *126a,b* attaching directly to the base portion *120*). In other embodiments, height *136* can be approximately equal to or greater than the length *133* of central tines *126a*. The support portions *141* can include smoothly contoured sides *143*, as illustrated, to diminish the likelihood that the support portions *141* will pierce the vessel wall *16* and/or cause trauma to the vessel wall *16*. In the illustrated embodiment, the outer surface of the support portions *141* is curved (e.g., similar in curvature to the outer surface of the base portion *120*). In some embodiments, the outer surface of the support portions *141* can be flat or can be shaped in a way different from the outer surface of the base portion *120*.

[00154] FIG. 5 is a side-view of clip 102 in a closed configuration. In a deployed state, clip 102 can define an angle 2 130 between a central axial line or an edge in fingers 122, 124 and a peripheral surface or an edge 131 of base 120. Angle 2 130 can be selected to assist in determining the applied closure force and to facilitate removal of clip 102 in embodiments using temporary closure, as explained further below. Angle 2 130 also can be selected to assist in determining the overall depth of penetration by the tines 126a, 127b into the vessel wall 16. For example, a smaller angle will generally produce a more shallow penetration and a larger angle will generally produce a deeper penetration. In some embodiments, Angle 2 130 can be greater than or equal to about 30° and/or less than or equal to about 70°. In some embodiments, Angle 2 130 can be about 30°, 35°, 40°, 45°, 50°, 55°, 60°, 65°, or 70° or any angle value therein to a 100<sup>th</sup> of a degree. In a particular example, Angle 2 130 can be about 50°. Other appropriate angles can also be used. In some embodiments, as illustrated, the flexion regions 400 can bend while other structures remain substantially unchanging or intact.

[00155] FIG. 6 is a bottom view of clip 102 in a closed configuration. As illustrated, opposed pairs of tines 126a, 126b can be configured to contact one another or to draw very close to each other (e.g., within a distance equivalent to about the thickness 137 of each tine 126a, 126b) in the closed configuration. In other embodiments, the tines 126a, 126 need not be configured to move very close to each other in the closed configuration. In some embodiments, base portion 120 has a side thickness 138 which can be greater than or equal to about 0.1 mm and/or less than or equal to about 0.5 mm. In some embodiments, base portion 120 has a side thickness 138 of about 0.1 mm, 0.2 mm, 0.3 mm, 0.4 mm or 0.5 mm or any size therein to about the 100<sup>th</sup> of a mm. In some embodiments, base portion 120 has a side thickness 138 of about 0.2 mm. As illustrated, in some embodiments, all portions of the clip 102 can share approximately the same thickness. The thickness can also vary between different portions of the clip 102 in appropriate circumstances. For example, referring to FIG. 4, tines 126a-b can have a thickness 137 which can be less than thickness 138 of the base portion 120 to facilitate penetration of the vessel wall 16.

[00156] Base portion 120 can define an outer diameter and an inner diameter. For example, the outer diameter can be greater than or equal to about 3 mm and/or less than or equal to about 7 mm, and the inner diameter can be greater than or equal to about 2.5 mm and/or less than or equal to about 6.5 mm. In some embodiments, the outer diameter is about 3.0 mm, 3.5 mm, 4.0 mm, 4.5 mm, 5.0 mm, 5.5 mm, 6.0 mm, 6.5 mm or 7.0 mm. In some embodiments, the inner diameter is about 2.5 mm, 3.0 mm, 3.5 mm, 4.0 mm, 4.5 mm, 5.0 mm, 5.5 mm, 6.0 mm or 6.5 mm or any size therein to about the 100<sup>th</sup> of a mm. In some embodiments, the outer diameter is about 5.3 mm and the inner diameter is about 4.8 mm. Other suitable diameters can also be used. Different size clips can be used depending on the specific tissue compression or closure application for which they are being used and to account for different anatomical sizes, such as differences in the thickness or diameter of the vessel wall 16. In some instances, a plurality of different-sized clips 102 can be provided to health care professionals to allow for variability and increased precision in diminishing trauma and increasing the appropriate closure force for a particular patient. Moreover, a clip size also can be selected to accommodate the tubular medical device over which the clip will be advanced. In

embodiments effecting arteriotomy closure, the clip's inner diameter should be large enough to be advanced over a standard commercial introducer.

[00157] As illustrated in FIG. 6, the tines can have straight edges *145* and define an inner angle  $\alpha$  *405*.

Angle  $\alpha$  *405* can be selected to help adjust an insertion force required to cause penetration of the tines *126a*, *126b* into or withdrawal of the tines *126a*, *126b* from the vessel wall *16*. In some embodiments, angle  $\alpha$  *405* can be greater than or equal to about  $3^\circ$  and/or less than or equal to about  $15^\circ$ . In some embodiments, angle  $\alpha$  *405* can be about  $3^\circ$ ,  $4^\circ$ ,  $5^\circ$ ,  $6^\circ$ ,  $7^\circ$ ,  $8^\circ$ ,  $9^\circ$ ,  $10^\circ$ ,  $11^\circ$ ,  $12^\circ$ ,  $13^\circ$ ,  $14^\circ$  or  $15^\circ$  or any value therein to about  $100^{\text{th}}$  of a degree. In some embodiments, angle  $\alpha$  *405* can be about  $9^\circ$ . Other suitable angles can also be used. The widths of the tips *127a*, *127b* of tines *126a*, *126b* can also be adjusted to determine a required insertion force. In certain embodiments, the width of tips *127a*, *127b* can be greater than or equal to about 0.03 mm, and/or less than or equal to about 0.09 mm. In certain embodiments, the width of tips *127a*, *127b* can be about 0.03, 0.04, 0.05, 0.06, 0.07, 0.08 or 0.09 mm or any size therein to about the  $100^{\text{th}}$  of a mm. In certain embodiments, the width of tips *127a*, *127b* can be about 0.06 mm. Other suitable tip widths can also be used. In certain embodiments, the edges of the tines *126a*, *126b* can be curved, segmented, or define different angles at different portions. In certain embodiments, the tines *126a*, *126b* can include barbs, protrusions, or other elements configured to resist withdrawal from the vessel wall *16*. The barbs can be sized or configured to provide sufficient resistive force to prevent accidental removal of the clip *102* during partial deployment of the clip *102* as explained in more detail below. In certain embodiments, the resistive force provided by the barbs can also be sufficiently small to permit atraumatic removal of the clip *102*.

[00158] For embodiments in which the base *120* is substantially circular, arc *406* corresponds to the circumferential width of fingers *122* and *124*. In the illustrated embodiment, arc *406* subtends an approximately  $90^\circ$  angle. In some embodiments, arc *406* can subtend an angle greater than or equal to about  $60^\circ$  and/or less than or equal to about  $90^\circ$ . In some embodiments, arc *406* can subtend an angle of about  $60^\circ$ ,  $65^\circ$ ,  $70^\circ$ ,  $75^\circ$ ,  $80^\circ$ ,  $85^\circ$ , or  $90^\circ$  or any value therein to about  $100^{\text{th}}$  of a degree. Other angles can also be used. Arc *403* corresponds to a circumferential width of window portions *125*. In some embodiments, arc *403* can subtend an angle between greater than or equal to about  $15^\circ$  and less than or equal to about  $30^\circ$ . In some embodiments, arc *403* can subtend an angle of about  $15^\circ$ ,  $16^\circ$ ,  $17^\circ$ ,  $18^\circ$ ,  $19^\circ$ ,  $20^\circ$ ,  $21^\circ$ ,  $22^\circ$ ,  $23^\circ$ ,  $24^\circ$ ,  $25^\circ$ ,  $26^\circ$ ,  $27^\circ$ ,  $28^\circ$ ,  $29^\circ$  or  $30^\circ$  or any value therein to about  $100^{\text{th}}$  of a degree. In certain embodiments, arc *403* can be less than or equal to about one-half the length of arc *406*. Connecting portions of fingers *122* and *124* adjacent to the window portions *125* can have widths defined by arcs *402* and *404*. Arc *139* corresponds to the separation distance between fingers *122* and *124*. In the illustrated embodiment, arc *139* subtends an angle of approximately  $90^\circ$ . In some embodiments, arc *139* can subtend an angle greater than or equal to about  $60^\circ$  and/or less than or equal to about  $90^\circ$ . In some embodiments, arc *139* can subtend an angle of about  $60^\circ$ ,  $65^\circ$ ,  $70^\circ$ ,  $75^\circ$ ,  $80^\circ$ ,  $85^\circ$ , or  $90^\circ$  or any value therein to about  $100^{\text{th}}$  of a degree. Other angles can also be used. In some embodiments, as illustrated, the shape and/or orientation of the base portion are substantially or entirely unchanged in the transition between an open or pre-deployed state and a closed or deployed state.

[00159] FIG. 7 is a perspective view of deployment instrument 104 with clip 102 in the open or pre-deployed position attached to a distal end thereof. The configuration illustrated in FIG. 7 is generally an initial or starting configuration before insertion of the deployment instrument 104 into a patient. The deployment instrument 104 with a pre-loaded clip 102 can be provided to the physician in a sterilized package in this general configuration. In certain embodiments, the deployment instrument 104 can be constructed with three basic components: inner tubular member 154, outer tubular member 156, and pressure element 158.

[00160] FIGS. 47A-D illustrate another embodiment of a vascular closure clip 350. Clip 350 as illustrated can be similar in many respects to clip 102 except as described below. A primary difference between clip 350 and clip 102 is that the arrangement of fingers 252, 254 on clip 350 is asymmetric: the number of tines 256, 258 on each side is not equal. For example, as illustrated, a first finger 252 can include three tines 256. A second finger 254 can include two tines 258. Tines 256 and tines 258 can be offset from one another and configured to interlace when clip 350 is in a closed configuration as seen in FIGS. 47B-D. For some applications, this interlacing configuration can provide certain advantages over the configuration of clip 102. For example, fingers 252 and 254 can be configured to apply greater compression to tissue and to more completely close the arteriotomy 14, by attempting to draw generally opposing sides of tissue past one another. In addition, the interlaced configuration can in some embodiments, permit a smaller angle 2 259 to be formed between a central axial line or an edge in fingers 252, 254 and a peripheral surface or an edge 253 of a base portion 251 for a given length of fingers 252, 254. In some embodiments, angle 2 259 can be greater than or equal to about 10° and/or less than or equal to about 50°. In some embodiments, angle 2 259 can be about 10°, 15°, 20°, 25°, 30°, 35°, 40°, 45°, or 50° or any value therein to about 100<sup>th</sup> of a degree. In a particular example, angle 2 259 can be about 30°. Other suitable angles may also be used. In the illustrated example of FIG. 47C, fingers 252 and 254 do not contact one another when clip 350 is in its closed or deployed configuration. In other embodiments, fingers 252 and 254 can be configured to contact one another in the deployed configuration. For example, tines 258 can be configured to rest on forward surfaces 253 of finger 252. Tines 256 can be configured to rest on forward surfaces 255 of finger 254.

[00161] FIGS. 48A-B illustrate another embodiment of a vascular closure clip 260. Clip 260 can be similar to other clips disclosed herein, except as described below. Clip 260 includes three symmetrical fingers 262 extending from annular base 261. As illustrated, fingers 262 can be uniformly spaced around the circumference of base 261. Each finger 262 can include two tines 264. Distal ends of tines 264 are configured to meet when clip 260 is in its closed configuration as illustrated in FIG. 48B.

[00162] FIGS. 49A-B illustrate another embodiment of a vascular closure clip 270. Clip 270 can include three symmetrical fingers 272 which can be uniformly spaced around the circumference of annular base 271. Clip 270 can be similar in many respects to clip 260. A primary difference between clip 270 and clip 260 is that the tines 274 of clip 270 are configured to overlap tines 274 of adjacent fingers when clip 270 is in a closed configuration.

[00163] FIGS. 50A-B illustrate another embodiment of a vascular closure clip 280. Clip 280 can be similar to other clips disclosed herein. Clip 280 can include three fingers 284, which can be substantially uniformly spaced around the circumference of annular base 281. Each finger 282 includes two tines 284 which are offset to one side from a central portion of the finger 282. This configuration can permit fingers to bend to a greater degree in the closed configuration without overlapping

[00164] FIGS. 51A-E illustrate another embodiment of a vascular closure clip 290. Clip 290 can be similar to other clips disclosed herein, except as described below. Clip 290 includes six fingers 292 substantially uniformly spaced around a circumference of base portion 291. In some embodiments, each finger 292 includes only a single tine 294. Tines 294 are configured to fold to a substantially flat configuration, best seen in FIG. 49D. Such a configuration permits clip 299 to have a relatively low interior profile. Tines 294 are not configured to contact one another when clip 290 is in a closed configuration. In other embodiments, tines 294 can be configured to meet at or close to a central point, or other point. Tines 294 include a distal-most portion 295 and a second more-proximal portion 296. Portion 295 defines a first interior angle which can be smaller than an interior angle defined by portion 296. Such a configuration gives tines 294 a relatively "sharp" tip and can facilitate the tines' initial penetration of vessel wall 16. Base portion has a height 298. As illustrated height 298 can be relatively small and can be, for example, approximately equal to or less than one fifth of a radius defined by annular base portion 291. A relatively small height 298 permits the clip 290 to have a relatively low external profile when implanted.

[00165] Clip 290 can provide more complete circumferential closure by being configured to engage tissue on substantially all sides of arteriotomy. In certain embodiments, it can be more desirable to use such clips 290 for permanent implantation and other clips for temporary implantation. For example, the use of only two opposed fingers can facilitate removal. The use of only two opposed fingers can create a "pinching"-type closing action which can be advantageously simple and predictable.

[00166] In certain embodiments, heat can be used to facilitate the closure of arteriotomy 14. FIG. 52 illustrates a circuit 500 using direct resistive element heating to heat tissue surrounding the arteriotomy 14. In certain embodiments, selected tissue surrounding the arteriotomy can be heated to a temperature which can be less than or equal to about 40°C, between about 40°C and 45°C, or greater than about 45°C. In certain embodiments, selected tissue surrounding the arteriotomy can be heated to a temperature of about 35°C, 36°C, 37°C, 38°C, 39°C, 40°C, 41°C, 42°C, 43°C, 44°C, 45°C, 46°C, 47°C, 48°C, 49°C, or 50°C or any value therein to about 100<sup>th</sup> of a degree. Other suitable temperatures may also be used. At these temperatures, tissue being compressed together by a vascular closure clip can undergo cellular changes that tend to fuse tissue together to close the arteriotomy.

[00167] Other clip variations are also possible. The tissue compression can be modified by adjusting one or more of several tissue engagement element design attributes, such as the length, width, thickness, angle, number and location of the elements, etc. The proximal edge of the clip can have a straight, sinusoidal, notched, keyed, combination or other suitable design. The proximal edge geometry can mate with a

contacting surface of the advancement and deployment instrument. Clips can be made from one or more of a tubing, sheet, wire, strip, band, rod, combination or other suitable material.

[00168] FIGS. 56A-C illustrate an additional embodiment of a vessel closure system. In one embodiment, a swellable plug 310 which can be bioabsorbable is loaded onto the distal end of a plug deployment instrument 300. Plug deployment instrument 300 can include an inner tubular member 302 with handle 306 and an outer tubular member 304 with handle 308. The proximal end 312 of plug 310 can be received by the distal end of outer tubular member 304. Intermediate stop portion 314 of plug 310 can have a larger outer diameter than either proximal end 312 or distal end 316 and is received against the distal end of the outer tubular member 304. As illustrated, stop portion 314 can have a generally circular geometry. However, other suitable shapes or geometries can be used. For example, in certain embodiments stop portion 314 can have a flared or tapered shape, a general 'X' shape, an inverted general 'T' shape, a combination or any other suitable shape or geometry. In certain embodiments, stop portion 314 can be slotted or ribbed to facilitate flexing during advancement. Proximal end 312 can be relatively long to facilitate plug kinking as will be described below. In certain embodiments, proximal end 312 can have a length that is greater than or equal to about twice the length of distal end 316, and/or greater than or equal to about five times the length of distal end 316. Plug 310 can include a longitudinal channel 318 allowing the deployment instrument 300 and plug 310 to be advanced over a tubular medical device in a similar fashion to that described above with respect to deployment instrument 104. Inner tubular member 306 can be advanced distally by applying pressure to handle 306 and/or by pulling handle 308 in a proximal direction. A stop means such as a removable element affixed to the outer tubular member 302 between handles 306 and 308 can maintain separation of handles 306 and 308 until the medical professional is ready to begin deployment. Once the medical professional has confirmed proper placement of the distal end of the deployment instrument 300, the stop means can be overcome by for example removing the removable element in order to begin deployment. The distal end of inner tubular member 306 pushes plug 310 free of the outer tubular member 304 to effect deployment. The deployment instrument 300 can be configured such that the plug 310 will be fully deployed when the handles 306 and 308 have been brought together.

[00169] Swellable plug 310 can be partially or completely fabricated from materials that swell or expand when they are exposed to a fluid, such as blood or subcutaneous fluid, or another fluid, for example, that can be added by the physician to cause the material to swell. These materials include hydrophilic gels (hydro gels), regenerated cellulose, polyethylene vinyl acetate (PEVA), as well as composites and combinations thereof and combinations of other biocompatible swellable or expandable materials. Upon deployment, swellable plug 310 can swell causing longitudinal channel 318 to be occluded and sealing the arteriotomy. In certain embodiments, plug 310 can be partially or completely fabricated from a lyophilized hydrogel, such as, for example polyethylene glycol (PEG) or other polymer carrier. The polymer used in the carrier can include hydrolytically degradable chemical groups, thereby permitting in vivo degradation. Hydrophilic polymeric materials suitable for use in forming hydrogels include poly(hydroxyalkyl methacrylate), poly(electrolyte complexes), poly(vinylacetate) cross-linked with hydrolysable bonds, water-swellable N-vinyl lactams

polysaccharides, natural gum, agar, agarose, sodium alginate, carrageenan, fucoidan, furcellaran, laminaran, hypnea, eucheuma, gum Arabic, gum ghatti, gum karaya, gum tragacanth, locust beam gum, arabinogalactan, pectin, amylopectin, gelatin, hydrophilic colloids such as carboxymethyl cellulose gum or alginate gum crosslinked with a polyol such as propylene glycol, and the like. Several formulations of previously known hydrogels are described in U.S. Patent No. 3,640,741 to Etes, U.S. Patent No. 3,865,108 to Hartop, U.S. Patent No. 3,992,562 to Denzinger et al., U.S. Patent No. 4,002,172 to Manning et al., U.S. Patent No. 4,014,335 to Arnold, U.S. Patent No. 4,207,893 to Michaels, and in Handbook of Common Polymers, (Scott and Roff, Eds.) Chemical Rubber Company, Cleveland, Ohio, all of which disclosures in the foregoing patents and publication regarding hydrogels are incorporated herein by reference.

[00170] An example of a method for using plug deployment instrument 300 and plug 310 will now be described with reference to FIGS. 57-63. The deployment instrument 300 loaded with plug 310 can be advanced over a previously installed tubular medical device 108 as shown in FIG. 57 until the distal end 316 encounters vessel wall 16. In certain embodiments, as illustrated, distal end 316 can be received within the arteriotomy 14. In other embodiments, distal end 316 can be received against an outer surface of vessel wall 316. Intermediate portion 314 can be configured to act as a stop to prevent over-insertion of plug 310 into the vessel. The introducer sheath can then be removed from the vessel as shown in FIG. 59.

[00171] As shown in FIG. 60, the deployment instrument 300 can be held in place against the vessel wall 316 while the exposed portions of plug 310 begin to swell. The swelling can be initiated or accelerated by various events, such as coming into contact with blood and/or subcutaneous fluid. In certain embodiments, the enlargement of distal end 316 can help to secure the plug 310 in place within the arteriotomy 14. The swelling of plug 310 can occlude longitudinal channel 318, tending to seal or otherwise partially or entirely fill the arteriotomy 14. Alternatively or additionally, the channel 318 can be occluded via kinking of proximal portion 312. Once the plug 310 is secured to the vessel wall 16, deployment instrument 300 can be removed as shown in FIG. 61. Fatty tissue that was previously displaced by the deployment instrument 300 may begin to fill in the tissue tract. This tissue can thus apply pressure to proximal portion 312 tending to kink or occlude it. Patient movement and/or externally or internally applied pressure can also be used to cause the proximal portion 312 to kink. Deployment of plug 310 at an acute angle to the vessel wall, as illustrated, can also increase the tendency of proximal portion 312 to kink. In certain embodiments, the inner surface of the longitudinal channel 318 can be configured to stick to itself when one region of it contacts another region.

For example, in certain embodiments inner surfaces of longitudinal channel 318 can be coated with an adhesive or other appropriate coating to assist in occluding the longitudinal channel 318. In certain embodiments, the adhesive or coating can be configured to avoid or to diminish adherence to the deployment instrument 300. FIG. 62 shows an embodiment of the deployed plug 310 in a fully swollen state. Plug 310 can be completely or partially bioabsorbable. In certain embodiments, plug 310 can be configured to be completely absorbed by the patient's body after about 4 weeks. Other suitable times may also be used.

FIG. 63 shows the plug 310 in a partially-dissolved state.

[00172] Swellable plug 310 can be shielded from unintended contact with fluid (blood, saline, etc.), before insertion into the body, by a removable wrapper or dissolvable coating. Swellable plug 310 can include a relatively rigid outer coating that begins to dissolve upon exposure to fluids such as blood, thus providing time for the medical professional to position the plug 310 within the arteriotomy. In some embodiments, a plug  
5 can be configured to be advanced directly over the tubular medical device 108 and deployment instrument 310 can be replaced with a pusher instrument. In certain embodiments, a plug can include a longitudinal slit or spiral allowing the plug to be attached to the tubular medical device or deployment instrument from the side. In certain embodiments, the deployment instrument can also include a slot allowing attachment from the side.

[00173] The vascular closure device can incorporate one or more coatings, materials, compounds, substances, drugs, therapeutic agents, etc., that positively affect healing at the site, at and or near where the device is  
10 deployed, either incorporated into the structure forming the device, incorporated into a coating, or both. Thrombo-resistance materials, antiproliferative materials, or other coatings intended to prevent thrombosis (acute and or chronic), hyperplasia, platelet aggregation, or other negative response, at or near the attachment of the device within the body. The coatings, materials, compounds, substances, drugs, therapeutic agents, etc.,  
15 can be used by themselves, and/or contained in a carrier such as a polymeric matrix, starch, or other suitable material or method. The coatings can be liquid, gel, film, uncured, partially cured, cured, combination or other suitable form.

[00174] Additional configurations of closure devices or clip, plug or closure device 670 are illustrated in FIGS. 79A-E. The clip, plug or closure device 670 has a plate section, wings or petals at a first end, an elongated  
20 neck section which is the core, stem, vertical section, mid-section, post or shaft, and a set of flanges 675 extending from the neck at an opposing end which are radially extending members, wings, petals or horizontal protrusions. As illustrated, the face plate is triangular and has three petal shapes on its distal end (the end within the wound) which meet centrally at a center point along the face plate and extend outwardly. The petals can be raised sections with scoring, or whatever configuration assists in allowing the face plate to bend toward  
25 the inner axis A during deployment. Additionally, a fewer or greater number of scored or raised petals can be provided. Additionally, the shape of the face plate may result in a different number of petals being used on the surface. The clip, plug or closure device 670 may further include an aperture or bore 676 through at least a portion of the elongated neck section or stem 672. Horizontal grooves can be provided around the core to reduce bleeding and for added sealing. The plug may also be coated in lubricant to assist vessel contact  
30 opening and to reduce the force required to advance the plug through the capsule and introducer sheath tubing or into the target site. The wound or vessel contacting surfaced may vary in thickness, profile and geometry and the middle plug core or stem may vary in thickness, profile, geometry, and/or any other aspect. Additionally, the middle plug section may be at least partially hollow. Moreover, any surface of the plug may be configured to have at least one smooth, textured, patterned, grooved, or a combination thereof. The plug  
35 may have at least one of a hole, notch, void, dimple, groove, slot, indentation, concave section, or any other desired configuration. Plug sections can be made from a single piece or multiple pieces. Where separate pieces are used, the separate pieces can be fixed or moveable. For example the plug may be configured so that

the outer vessel contacts can be moved toward the inner vessel contacts, contacting (and compressing, if desired), the vessel. The moveable outer vessel contacts may be configured to maintain its position, relative to the vessel wall and/or inner vessel contacting area, by any suitable technique, including a single or two way ratched and/or one or more of either or both of bump(s) or protrusion(s) between the core (column) and the outer vessel contacts, enabling a custom or optimized fit between the inner and outer vessel contacts. The plug may have at least one of a radially extending inner vessel element, and a radially extending outer vessel element. The outer vessel element may be located at any point on the center (e.g., at axis A) or core of the plug, and may not necessarily be in direct or close contact with the outer vessel wall surface. The inner vessel member and one or more vertical cores, when deployed (unconstrained), upper ends of the core may move (all together, independently, or a combination) to an open position into an expended or larger cross-section from the constrained or deflected position during advancement using a tubular medical device.

[00175] The triangular plate section or face plate **680** is adapted and configured to be placed on an interior surface of a tissue layer to be sealed, with the elongated neck **672** extending through the wound, and two or more flanges **675** positioned exteriorly to the wound and proximal to the deployment device. The face plate can be configured such that it is flat on a proximal side and convex on a posterior side. With the face plate further being scored along its posterior face to facilitate conforming the face plate into a low profile configuration for delivery. The stem or core can be straight, curves, angled or a combination thereof.

Moreover the stem can assist in achieving plug contact and/or attachment to the vessel. Additionally, the device may be substantially straight during deployment or advancement through the introducer sheath, and then moved to another configuration when it is no longer constrained within the tubular medical device (such as an introducer sheath). The devices and systems can be configured to provide a partial or complete circumferential closure device to secure an implantable device, such as a ventricular assist device. Rotation and/or detent may be incorporated into the system for a final plunger forward advancement movement and confirmation that the plug is fully deployed and the sheath is ready to be withdrawn.

[00176] For purposes of illustration in the context of a device that is delivered *in situ*, a suitable configuration of the plugs disclosed herein provides for a length of about 3.81mm to about 5.08mm, or more preferably about 4.39mm, or any value therein to about the 100<sup>th</sup> of a mm. The bore has a length of about 2.92mm to about 3.94mm, or more preferably about 3.43mm, or any value therein to about the 100<sup>th</sup> of a mm. The width of the bore is about 0.76mm to about 1.27mm, or preferably about 1.00mm, or any value therein to about the 100<sup>th</sup> of a mm. The stem of the plug between the cap and the flanges **675** ranges from about 3.30mm to about 3.81mm, more preferably 3.48mm, or any value therein to about the 100<sup>th</sup> of a mm. The overall diameter of the device ranges from about 3.81mm to about 4.57mm, or more preferably 4.27mm, or any value therein to about the 100<sup>th</sup> of a mm. As shapes are not necessarily circular, these values can represent, for example, a diameter of a two-dimensional circular shape that encompasses the flanges **675** or the face plate. Devices that are used from outside the body (e.g., to repair an external wound in lieu of compression, would be sized larger).

[00177] Additional configurations of closure devices or clip, plug or closure device **670** are illustrated in FIGS. **79F-J**. The clip, plug or closure device **670** has a plate section, wings or petals at a first end, an elongated neck section which is the core, stem, vertical section, mid-section, post or shaft, and proximal bail or loop **675'** extending from the neck at an opposing end for attachment to a tether line, where the tether is looped through the bail and when the tether loop is cut it pulls out through the loop **675'**. The clip, plug or closure device **670** may further include an aperture or bore **676** through at least a portion of the elongated neck section or stem **672**.

[00178] The clip, plug or closure device **670** can be deployed in combination with, for example, a removable tether. The use of a tether allows confirmation of proper placement and sealing of the seal and reduces inadvertent manipulation of a deployed clip, plug or closure device **670**. The tether can be, for example, a thread, wire, and/or coil. The tether can be made from cotton, polymer, metal, metal alloy, and may be compliant, semi-rigid, rigid or of a changing rigidity. The tether may be pre-shaped, using nitinol for example, or any suitable material including silk, metal or metal alloy or polymer. The pre-shaped tether may be configured to hold the plug during deployment, and then pulled out or away from the plug, separating from the plug and withdrawing from the body. Additionally, the tether may be a separate component, and/or integrated into the design of the plug, and may include at least one weakened section designed to separate from the plug at a specific section. In some configurations, the tether may be adapted to separate from the plug by pulling, pushing, twisting, or combinations thereof or any other separation mechanism. Moreover, the tether may be configured to be separable, as shown in some embodiments herein, by a weakened area, the strength of the tether, the strength of the attachment between the tether and the plug or combinations thereof.

[00179] As shown in FIGS. **80A-C** the clip, plug or closure device **670** can be configured to provide a collapsible clip, plug or closure device **670** with a distal end **80** that fits within an opening on the proximal end **70** of the clip, plug or closure device **670** and is attached to a tether or wire **674** at its proximal end **70** that, when pulled, causes the clip, plug or closure device **670** to collapse. The delivery system and wire **674** are then withdrawn through the delivery device and the entire delivery system is completely disengaged, leaving the clip, plug or closure device **670** deployed *in vivo*. FIGS. **81A-N** illustrates other removable configurations wherein a tether or wire **674** is used to allow confirmation of proper placement and seating of the clip, plug or closure device **670**. As shown in FIG. **81A**, a bent wire **674** is routed through a central bore **676** in the clip, plug or closure device **670**. The wire **674** is configured such that a force required to straighten the wire and pull it through the bore **676** is equal to a release force. As shown in FIG. **81B** the wire **674** can be configured to spring away from a central axis **A** as the wire **674** is pulled proximally toward the user and away from the clip, plug or closure device **670**. In FIG. **81C** the wire **674** is configured with a wavy bend such that the apex of the bends engages the side walls **678** of the tubular channel **678'** formed in the clip, plug or closure device **670**. The distal end **80** of the wire **674** can engage the plug face plate **680** in a semi-permanent configuration such that a force is required to disengage the wire **674** from the clip, plug or closure device **670** and withdraw it through the channel. As shown in FIG. **81D** the channel can include a groove or well into which a bend in the wire extends forming a detent **636**. A suture line can be used as shown in FIG. **81E**. The suture line **674**

can be configured to disengage from the clip, plug or closure device **670** as shown. Other configurations include, for example, a bent wire **674** configuration as shown in **FIG. 81F**, where a helical coiled wire **674** is configured to decrease in outer diameter when tension is applied. **FIG. 81G** illustrates a staggered or bent bore or channel **678** in the clip, plug or closure device **670** through which a strained wire **674** is positioned. The strained wire **674**, thus must flex through the staggered or bent bore or channel **678**. In **FIG. 81H** the wire **674** is configured to have an elongated S curve with a sharp tip that points away from the pull direction (e.g., toward the distal end **80**). As shown in **Figs. 81e-h**, a portion of the line **674** can extend through the distal surface of the cap **680** taking a variety of configurations parallel to the cap **680** surface or coiled.

**[00180]** Other concepts include, for example, tethered clip, plug or closure device **670** concepts where, for example, a tether **674** in the form of a loose thread passes through an aperture **679** on a proximal end **70** of the clip, plug or closure device **670** as shown in **FIG. 81I**. Alternatively, the proximal end **70** of the clip, plug or closure device **670** could be in the form of a safety pin clasp as shown in **FIG. 81J** which unhinges to release the tether **674**. A pincher clasp could likewise be used, as shown in **FIG. 81K**, or a snap and ball socket as shown in **FIG. 81L**. A molded-in break point could also be used such that the bolded break point breaks when tension is applied from a proximal end **70** as shown in **FIG. 81M**. In another configuration a ribbon section is used as shown in **FIG. 81N**.

**[00181]** Additional release concepts are shown with respect to **FIGS. 82A-B**. The configuration illustrated in **FIG. 82A** relies on an overstretch section at a weak point along the length of the stem of the closure device **670**. Over-stretch can be combined with a twist action that results in a snap of the stem **672** along its length. In some configurations, as shown in **FIG. 82B**, tear notches can be provided which enable the stem **672** to be separated using a tear motion, which then tears along the tear notches, and releases the clip, plug or closure device **670**. A cutter can be used in combination with a tether tube **678'**. As will be appreciated by those skilled in the art, a radiopaque marker can be employed, such as a tungsten ball, such that the device can be seen on an x-ray monitor or other imaging device. The radiopaque marker can be positioned such that it is part of a break-away portion of the plug such that it can be removed when it is no longer clinically necessarily or desirable to have the marker in place.

**[00182]** Tethered clip, plug or closure device **670** are also contemplated. Tether clip, plug or closure device **670** can use, for example, a ball-and-socket design as shown in **FIG. 83A**. In this configuration, a molded ball is provided on the plug stem. The molded ball socket has one or more splits. When opened, the splits form finger than can easily open to release the ball within the socket. As shown in **FIG. 83B** a tether line **674** can be provided in combination with a tether tube **682**. The tether tube restrains the fingers formed in the molded ball socket and restrains the fingers from opening. This maintains a secure grip on the ball until the tether line **674** and tube **682** are retracted. When the tether tube and line are retracted, as shown in **FIGS. 83C-D**, the ball is withdrawn as well. This configuration has very high grip security on the plug via the tether line until the user slides the tether tube **682** from the end.

**[00183]** In another configuration, the tethered clip, plug or closure device **670** can be used in conjunction with a ball-socket tether tube **682**-tether line **674** as shown in **FIG. 84A**. The ball can be positioned such that it is

fixed in relation to the ball and tether tube 682 end. A release button 684 configuration can be used to lock the tether tube 682 in place, wherein movement of the tether tube 682 along an axis A stops when the one or more buttons reach a detent 636. As shown in FIG. 84B the tether tube 682 can retract past the end of the clip, plug or closure device 670, for example when the release button is pushed. The diameter of such a configuration is about 1.0 to 2.5 mm, or more preferably about 1.5 to 2.0 mm, or any diameter therein to about 100<sup>th</sup> of a mm. In a snip-off design shown in FIGS. 84C-D, the tether tube 682 travels to a button stop 684, similar to the configuration shown in FIG. 84A and then is snipped at a cut line near a proximal end 70 .

[00184] Further to the designs depicted in FIGS. 79-84 a variety of clip, plug or closure device 670 profiles is also contemplated. As shown in FIG. 85A the closure device 670 can have a round or substantially round disk or face plate 680 at a distal end 80 with a stem 672 protruding from a proximal surface of the disk. The stem 672 can be a locating, centering and/or anchoring stem. As will be appreciated by those skilled in the art, the stem 672 can have a variety of configurations as shown in more detail in FIGS. 85B-R. The stem 672 can be configured to have a square or rectangular cross-section as shown in FIG. 85B which could then be a variety of cross-sections along its perpendicular axis to the one depicted (e.g., round, square, etc.), a triangular cross-section as shown in FIG. 85C which could then be, for example, pyramidal or conical in three dimensions, a stem with an arrow-head as shown in FIG. 85D with the same three -dimensional considerations previously described, have a concave proximal surface as shown in FIG. 85E, a convex proximal surface as shown in FIG. 85F, a combination of a stem with an arrow-head having a concave surface adapted to receive a mating ball as shown in FIG. 85G, a stem with an aperture perpendicularly through the stem to receive, for example, a wire, as shown in FIG. 85H, a stem with flanges 675 tapered distally as shown in FIG. 85I, a stem shaped as a trapezoid with its wide edge being positioned proximally and its narrow edge adjacent the disc portion of the closure device. In another configuration, the stem is shaped as a hook in cross-section with a rounded hook as shown in FIG. 85K or a catch as shown in FIG. 85L. Additionally, effective is the use of a protuberance as part of a detent 636 system as shown in FIG. 85M, or a channel which opens to receive a mating element having a wider head as shown in FIG. 85N. A variety of screw configurations can also be employed for the stem 672, as shown in FIGS. 85O-P. Standard threading of the stem 672 can be used, as shown in FIG. 85O. Alternatively, internal threading in a bore of the stem 672 can be used as shown in FIG. 85P. A bi-stable geometry can also be used as shown in FIG. 85Q-R.

[00185] The closure device can also be configured to provide for inner petals as shown in FIGS. 86A-E. The stem 672 of such a configuration could have a small diameter under 1mm with an optional suture line. Various stem options are included which illustrate ribs and nibs on both sides of the distal sealing surface or skirt. As shown in FIG. 86A, the stem 672 can have bulbous sections along its length which have a diameter greater than the small diameter of the stem. Alternatively, the neck can be less than 1mm, or any value to 10mm as shown in FIG. 86B but end with a flat disk 680 at its proximal end 70 in communication with a suture line 674. As shown in FIGS. 86C-D a closure device 670 could be pressed into place with the disk 680 configured such that the outer edges can move towards a central axis A as the device 670 is pressed through a wound, and then open up once in, for example, the vessel with the disc placing pressure on the vessel wall to retain its

position. As shown in FIG. 86E, the device 670 can be configured to have a hollow plunger which seats under the cap of the device. A variety of configurations of the disk can be employed and post configuration on the surface of the disk can be employed without departing from the scope of the disclosure as will be appreciated by reviewing FIGS. 87A-B and FIGS. 88A-F. As shown in FIGS. 87A-B the device 670 comprises a disk 680  
5 that can be substantially flat from a side view and substantially round from an end view, with a post or stem 672 and/or tether or suture line 674 centrally positioned on the disk 680. As shown in FIGS. 88A-F the disk 680 can be round, triangular, oval, ovoid, square, triangular and elongated (with wings). Typically these shapes will also have rounded edges, for example, a square or triangular shape could be rounded at the corners as shown in FIGS. 88B. Moreover, the sides can be bent inward toward a central point such that, for example,  
10 a triangular shape becomes closer to a Y shape as shown in FIG. 88C. Additionally, a variety of side profiles can be employed as shown in FIGS. 88D-F, for example flat, concave, convex, flat on one side and convex or concave on the opposing side, with or without an interior chamber as shown in FIG. 88E. In some configurations, ribs and nibs 686 can be provided on one or more surfaces to facilitate anchoring the device *in situ* as shown in FIGS. 88F and 89A-G which illustrate embodiments and embodiments deployed *in situ*. Nibs  
15 686 on a proximal surface will, when the device 670 is inserted into, for example, the vessel, engage the interior surface of the vessel to prevent withdrawal of the device 670 and to minimize or eliminate movement of the device *in situ*.

[00186] The closure device can also be configured with snap-action geometry. FIGS. 93A-D and FIGS. 94A-D show a plug with snap-action geometry. Snap-action geometry can be incorporated into any clip, plug, or  
20 closure device, including any other embodiments discussed elsewhere herein. A clip, plug, or other closure device may have one or more protruding or radially extending surface. For example, a plug/sealing element may incorporate a radially extending member, flexible cap, flange, wing, finger, skirt, ridge, face plate, round disk, or protrusion. Any description of any form protruding or radially extending surface may apply to any other type of protruding or radially extending surface. In some examples, a plug may be either molded in a  
25 convex or concave shape and then being deflected into the opposite shape. FIGS. 93A-D illustrate an example of a plug 930 with a circular disk 932. Features of the plug may be applied a disk of any shape. FIGS. 93B-D illustrate side views of the plug in various states. The plug may have a petal configuration with a skirt 932 and stem 934. The plug may have a neutral state, a maximum strain state, and an overextended state. The neutral state may be a convex shape or a concave shape, and the plug may be deflected into the opposite shape. For  
30 example, as shown in FIGS. 93B-D, the neutral state may be a convex shape. The plug may be deflected into a concave shape. In another example, as shown in FIGS. 94B-D, the neutral state may be a concave shape. The plug may be deflected into a convex shape.

[00187] In embodiments of the invention with over center and snap action geometry, the plug 940 may have a petal geometry with a skirt 942 and stem 944. The petal geometry may be molded in a configuration, such  
35 that as it is deflected into another shape, it passes through a shape with a maximum total strain energy, then further deflection results in less total strain energy and the geometry will (depending upon the design geometry): (A) continue to deflect but with decreasing force being required to cause additional deflection into

the final state; or (B) once the petal is deflected even slightly past its maximum total strain energy geometry configuration, it will continue (by releasing the stored strain energy) deflect without further applied external deflection forces, into the final deflected geometry and will remain in that shape without further external supplied forces ( this is a second metastable position).

5 [00188] Providing a snap-action geometry to a skirt of a closure device may provide advantages over a flat skirt. For example, the snap-action geometry may advantageously increase the amount of force required to fold back the skirt. Force applied to a flat skirt could cause the material to fold or buckle, which may not provide as great a resistance to it folding up. The main resistance may be from the thickness of the material or any ribs, if any. With snap-action geometry, the force required to fold the skirt back in one direction may be  
10 increase substantially compared to a flat skirt. The material at the outer rim of the snap-action geometry skirt may have to stretch as the rim flexes from a slightly smaller diameter to a larger diameter (e.g., when the skirt is in a maximum strain state). Once forced past the maximum strain state, the skirt can pop into a position nearly as concave as it had been convex (or vice versa). This may provide resistance to any initial or momentary forces while the plug is being anchored.

15 [00189] Another advantage is that when the plug is deployed, it may snap into a concave configuration, which may be closer to the shape of the inner wall of the vessel (e.g., artery) than if the skirt was flat. This may improve sealing, or the closure device's ability to conform against the vessel.

[00190] The closure device can also be configured with self-intersecting geometry. FIGS. 95A-C show a plug with self-intersecting geometry. Self-intersecting geometry can be incorporated into any clip, plug, or closure  
20 device, including any other embodiments discussed elsewhere herein. FIGS. 95A-C illustrate an example of a plug 950 with a circular disk 952. Features of the plug may be applied a disk of any shape. Side views are shown of a plug 950 with a skirt 952 and stem 954. The plug may have a first state where sections of the skirt form a convex shape with bendable features 956 that may be bent in a first direction. The plug may have a second state where sections of the skirt have a relatively straight configuration where bendable features 956  
25 are not substantially bent. The plug may also have a third state where sections of the skirt form a concave shape where bendable features 956 may be bent in a second direction. The second direction may be opposite the first direction. The bendable features may have a geometry that may limit the extent to which the bendable features may be bent into the second direction.

[00191] In embodiments of the invention with self-intersecting geometry, the plug 950 may have a petal  
30 geometry with a skirt 952 and stem 954. The geometry of the plug may be designed such that when deflected in one direction the geometry is open and there is no, or minimal interaction with other areas of the skirt. If configured with very thin sections (as shown) these sections may create natural locations for flexure with minimal applied external force. Such natural locations may be bendable features. In some embodiments, the bendable features or thin sections may be located between one or more protrusions 958, ribs, or other forms of  
35 geometry that may come into contact with one another. In some embodiments, the protrusions may form a radial pattern. In some embodiments, the protrusions may form a flower shape with one or more central protrusion 958a, and one or more surrounding protrusion 958b. Any number of central protrusions may be

provided. The amount of protrusions or angles of protrusions may determine at what angle the protrusions might start self-intersecting.

[00192] When the deflective forces are applied in the opposite direction, the geometry may at some point (deliberately calculated) come in contact between two areas of the surface, which may cause an increase in the force needed to deflect the geometry an additional increment. The curve of deflection vs. applied force may have a sudden change in slope at that point where the geometry begins to self-intersect. FIGS. 89A, 89C illustrate another way self-intersecting geometry could be achieved (e.g., with discontinuous concentric ribs). A spiral could also provide an additional example of a self-intersecting geometry. In some embodiments, the self-intersecting geometry may have a flower shape.

[00193] Providing a self-intersecting geometry to a skirt of a closure device may advantageously provide flexibility/deflection in one direction, while resisting deflection (i.e. is rigidified) in the opposite direction. The skirt of the closure device may be free to flex in the direction without the intersecting geometry, but flexibility in the opposite direction (side with the self-intersecting geometry) may be limited. This design may allow a plug skirt to easily deflect backwards while the plug is being advanced through an introducer sheath. Once the plug has been advanced past the end of the introducer sheath, the self-intersecting geometry may limit the deflection in the opposite direction, so the plug may resist being pulled out of the vessel when the introducer sheath is withdrawn from the body. A self-intersecting geometry may allow for a pre-determined and predictable amount of flexibility or deflection.

[00194] Any of the clips, plugs, or closure devices described herein may be a single piece. For example, a skirt and a stem may be formed of a single piece. A stem and any other radially extending member/sealing element may be formed of a single piece. The radially extending members may deflect during deployment and may expand/deflect back when the closure device exits a distal end of the introducer sheath and is no longer constrained.

### (c) Guided Tissue Cutter

[00195] FIGS. 40-42 illustrate an example of a tissue opening widener such as a guided slidable tissue cutter 106, which can be used in a vessel closure system 100 in certain embodiments. After completing the desired medical procedure, the medical professional can temporarily attach tissue cutter 106 by clipping it onto the tube section 110 of the vascular introducer 108 as shown in FIG. 1. The tissue cutter 106 can then be slidably advanced along the vascular introducer sheath 108. The cutter 106 can be configured to make an incision of a precise depth and width at the site of the percutaneous opening 12 using sharp distal edges 203 of blades 202. The cutter 106 generally positions the edges 203 of the blades 202 at a specific orientation and distance from the tube 110 to permit a consistently and modestly sized entry point for the deployment instrument 104. A ledge such as mechanical stops 208 can ensure that the incision is not any deeper than needed to facilitate entry of the deployment instrument 104. Using the existing introducer sheath 108 as a guide for the slidable tissue cutter 106 also assists in ensuring proper placement of the incision. After making the incision, the slidable tissue cutter 106 can be removed from the side of the vascular introducer.

[00196] FIGS. 41-43 illustrate an example of a frame portion 200 which can form a component of a slidable tissue cutter 106. In certain embodiments, scalpel blades 202 can be secured to frame portion 200. In other embodiments, the cutter 106 can use specialized blades and/or be formed from a single piece. As illustrated, slidable cutter 106 includes two blades 202 positioned on lateral sides, such as in a diametrically opposite position from one another. In other embodiments, a single blade or three or more blades can be used. In certain embodiments, the cutting surfaces of each blade 202 can be static and configured to cut tissue without requiring interaction with a second cutting surface. In other embodiments, dynamic blades can be used.

[00197] Slidable cutter 106 can include a channel 206 with a partial circumferential cross-sectional geometry as shown in FIG. 43. This geometry enables a "snap-on" feature permitting the cutter 106 to be easily and temporarily attached to the tubular medical device and facilitating removal of the cutter 106 once the desired tissue has been cut. In other embodiments, a slidable cutter can use two mating pieces that clamp or snap together to facilitate temporary attachment and removal. In a preferred embodiment, channel 206 is sized so as to be compatible with any commercialized introducer sheath. The ends 208 of the frame portion 200 act as mechanical stops to control the depth of the incision. In some embodiments, handle portions 204 can extend beyond the end of channel 206 to facilitate handling by the medical professional at a distance from the sharp edges 203. Advantageously, such a configuration can facilitate the medical professional's control of the instrument without requiring an increase in the length 205 of channel 206. Most commercially available vascular introducers are between 11 and 13 cm long. Once inserted into a patient's vessel, the exposed portion of the introducer's tube section can be relatively small. Thus, it can be desirable to limit the amount of tube section that is taken up by the attached cutter and hence to reduce the length 205 of channel 206. The proximal ends of the handle portions 204 can be flared outwardly as illustrated to provide increased space between the cutter 106 and the tube 110 for improved manual access and manipulation, and to permit the deployment instrument 104 to be positioned as close axially as possible to the generally short exposed length of tube 110. The lateral edges of the cutter 106 can be tapered as illustrated.

[00198] Frame 200 can include recesses 210 sized to receive scalpel blades 202. The recesses 210 can be used to shield portions of the blades 202 not intended to cut tissue. Scalpel blades 202 can be secured to frame 200 via one or more of a variety of known methods such as, for example, friction-fitting, mechanical interference fitting, sonic welding, adhesives, screws, clamps, and the like. As illustrated, scalpel blades 202 are configured to angle inward toward one another slightly. Such a configuration can help to ensure that the blades 202 cut tissue immediately adjacent to the percutaneous opening 12. In other embodiments, scalpel blades 202 can be oriented in a substantially parallel configuration. In some embodiments, the blades 202 can be adjustable, allowing a medical professional to adjust one or more of the incision's depth, width, and angle, and/or a collection of cutters 106 of different sizes can be provided for different applications. In certain embodiments, slidable tissue cutter 106 is configured to cut substantially only the patient's skin. Fatty tissue located beneath the skin will generally move out of the way of the deployment instrument 104 with minimal resistance. Accordingly, a deeper incision may not be necessary in some embodiments.

[00199] The cutter *106* can be made from one or more of the following materials: polymers, including Nylon, polyamide, polycarbonate (e.g., Makrolon®), acrylonitrile butadiene styrene (ABS), polyester, polyethyleneterephthalate (PET), polyetheretherketone (PEEK™), polyimide, superelastic / shape memory polymers and metals, including spring steel, stainless steel, shape memory metal alloys including nickel titanium alloys (Nitinol), 17-7 PH, cobalt-chromium-nickel alloy (Elgiloy®), and nickel based alloys with chromium and iron (Inconel®). Other appropriate materials can also be used. In embodiments using a "snap-on" feature the frame *200* can be sufficiently flexible to allow the walls of the channel to bend outwardly to accommodate the tubular medical device *108*. The slidable cutter *106* can be completely or partially fabricated using one or more of the following methods: casting, laminating, machining, molding (injection or other), sintering, stereo lithography. Other suitable methods can also be used. Advantageously, the slidable tissue cutter *106* can be inexpensive to produce and designed for one-time use. In other embodiments, the tissue cutter *106* can be designed for repeated use following sterilization. An additional advantage of slidable tissue cutter *106* is that it allows for greater precision and ease of use than a hand-held scalpel and is less dependent upon the medical professional's skill and care.

(d) **Guided Tissue Dilator**

[00200] FIGS. 44-46 illustrate an example of a guided slidable tissue dilator *220* which can be used in a vessel closure system *100* in certain embodiments. Tissue dilator *220* can be configured to dilate the tissue tract before the deployment instrument *104* and can be moved through the opening in the skin. Tissue dilator *220* can be generally tube-shaped and configured to snap onto and off of the existing introducer sheath. Dilating the tissue before the advancement of deployment instrument *104* creates a temporary pathway through the tissue, making it easier to advance the deployment instrument *104* forward to the vessel wall *16*. After dilating the tissue tract, the tissue dilator *220* is then slid backwards and removed from around the introducer sheath.

[00201] Tissue dilator *220* can include an elongate tubular portion *223* with a channel *222*. Tubular portion *223* can include a tapered distal end *226* to facilitate insertion of tissue dilator *220* through the percutaneous opening *12*. Tissue dilator *220* can include a base *221* with handle portions *224* extending beyond the end of channel *222*. As illustrated, surfaces of handles *224* can be positioned in a plane generally parallel to a longitudinal axis of tubular portion *223*. In other embodiments, handles *224* can be positioned at an appropriate angle, such as, for example, an angle of at least approximately 90 degree angle. Angled handles can advantageously provide a surface to push on that is perpendicular to the direction of applied force. As with the cutter *106*, ends *228* of base *221* can act as mechanical stops to limit the depth of insertion. The medical professional can advance tissue dilator *220* until its distal end *226* encounters the resistance of the vessel wall *16*. As with the cutter *106*, channel *222* can have a partial circumferential cross-sectional geometry enabling it to "snap on" to an introducer sheath or other medical device. In other embodiments, a tissue dilator can use two mating pieces that clamp or snap together to facilitate temporary attachment and removal. In the illustrated embodiment, tubular section *221* includes a distal section *230* and a proximal section *232*. Distal section *230* has a greater partial-circumferential cross-section than proximal section *232*.

In other embodiments, tubular section *221* can be substantially uniform along its length. Tissue dilator *220* can be made from materials and methods similar to those described above with reference to tissue cutter *106*.

(e) Heated Systems

[00202] Heat can be used with any of the vascular closure clips described above, such as, for example clip *102*. A power source *502* such as an RF power source is provided. Other suitable power sources such as a DC power source can be used. Power source *502* is connected to a resistive element *508* via conductors *504* and *506*. Clip *102* can function as the circuit's resistive element *508*. In certain embodiments, only a portion of clip *102* will function as the resistive element. Clip *102* can be treated to increase its resistance value by, for example, being covered with a resistive coating. An increased resistance can reduce the power level necessary to effectuate a given amount of heating. In certain embodiments, portions of the clip *102* are covered with a thermally and/or electrically insulative coating. The remaining, uncovered portions of clip *102* can be configured to transfer thermal energy to the tissue being heated. In certain embodiments, only the tines or a distal portion of the tines are configured to transfer the thermal energy to the tissue. Conductors *504* and *506* can include wires made from a suitable electrically-conductive material such as copper-clad steel. In certain embodiments, conductors *504* and *506* can also function as tethering elements to allow removal of clip *102*. Conductors *504* and *506* can be covered with an insulating cover or coating. A thermocouple *512* can be mounted to the clip to monitor the temperature of the clip and/or the surrounding tissue. The recorded temperature can be provided to a user display *510* and/or controller *514*. Controller *514* permits the medical professional to adjust the amount of power delivered to the resistive element *508*. In certain embodiments, the power delivered can be less than about 2 W, between about 2 and about 50 W, or greater than 50 W. In certain embodiments, the power delivered can be about 2 W, 3 W, 4 W, 5 W, 6 W, 7 W, 8 W, 9 W, 10 W, 11 W, 12 W, 13 W, 14 W, 15 W, 16 W, 17 W, 18 W, 19 W, 20 W, 21 W, 22 W, 23 W, 24 W, 25 W, 26 W, 27 W, 28 W, 29 W, 30 W, 31 W, 32 W, 33 W, 34 W, 35 W, 36 W, 37 W, 38 W, 39 W, 40 W, 41 W, 42 W, 43 W, 44 W, 45 W, 46 W, 47 W, 48 W, 49 W, or 50 W or any wattage therebetween. Other suitable wattages may also be used. The medical professional can maintain the tissue at the desired temperature for a certain length of time. In some embodiments, heat can be applied to the tissue for a period less than or equal to about 30 seconds, or greater than 30 seconds. Other suitable times may also be used.

[00203] Following the application of heat, the conductors *504*, *506* can be disconnected from clip *102* in many ways. For example, a twisting, cutting, or other manipulative action can be used to remove the conductors. In embodiments using temporary or removable clips, conductors *504*, *506* can be used as a primary or backup tethering element to remove the clip *102* following hemostasis. In certain embodiments, conductors *504*, *506* can be connected to the clip *102* via spot welding, mechanical fit, soldering, combination, or other suitable method. Conductors *504*, *506* can be fabricated from many different materials, such as copper, platinum, stainless steel, or a composite of materials (e.g. copper clad steel or platinum and silver combined by a drawn filled tubing process). In certain embodiments, conductors *504*, *506* can include composite signal wires using silver as the inner core to better transmit, for example, radiofrequency or direct current energy. Conductors *504*, *506* can be fabricated with a circular, elliptical, rectangular (flat), or other geometry which may depend

on the space available on the clip *102*. Conductors *504*, *506* can be covered or jacketed with an insulative material such as polyimide, polyamide, polyurethane, polyester, nylon, or other suitable material.

[00204] In certain embodiments, a special tip can be placed over a standard electrosurgical tool such as, e.g., a Bovie Instrument (i.e., digital electrosurgical generator and accessories by Bovie Medical Corporation), to insert through the skin and make contact with the closure device and/or tissue. In certain embodiments, alternative heating means can be provided to heat the clip and/or the adjacent tissues including, for example, ultrasound energy, microwave energy, etc.

[00205] FIG. 53 illustrates a circuit using ohmic tissue heating to heat tissue. A power source *502* such as a radiofrequency (RF) or direct current (DC) power source is provided. Power source *502* is connected to an active electrode *524* via conductor *526*. Clip *102* can function as the active electrode *524*. Alternatively, only a portion of clip *102* can function as the active electrode *524*. For example, in certain embodiments, one or more of the clip's tines or only a portion of the clip's tines such as the distal-most portion can function as the active electrode *524*. In certain embodiments, remaining portions of the clip *524* are covered with an electrically insulating cover or coating. A second conductor *528* connects power source *502* to an indifferent electrode *522*. The indifferent electrode *522* can be, for example, an electrode plate or large surface area indifferent ground pad applied to the patient's skin. The indifferent electrode *522* can be placed on the patient's back, thigh or other location. The indifferent electrode *522* can be applied to a portion of the patient's skin generally opposite the percutaneous opening. The power supply *502* applies a voltage differential across the active and indifferent electrodes *524*, *522* causing current to flow through the intervening tissue thus heating the tissue. The heat is generally concentrated at tissue adjacent to the active electrode *524*. Controller *514* can permit the medical professional to adjust the amount of power delivered.

[00206] In another embodiment (not shown), a first portion of the clip can act as a first electrode and a second portion of the clip can act as a second electrode. The first and second portions of the clip can be electrically insulated from one another. For example, a first finger or a portion of the first finger such as one or more tines can act as the first electrode and a second finger or a portion of the second finger can act as the second electrode. A power source applies a voltage differential across the first and second electrodes causing current to flow between them and heat intervening tissue.

[00207] An electrode-enabled closure device can also be used to confirm contact between the closure device and the tissue surface, such as by comparing the impedance between an electrode element and a return path (indifferent electrode or second electrode). When an electrode surface contacts only or primarily blood, the measured impedance can be substantially higher than when a small or substantial portion of the electrode surface contacts tissue.

[00208] FIGS. 54-55 show another embodiment of an inner tubular member *154'* which can form one component of a deployment instrument. Inner tubular member *154'* can be similar to inner tubular member *154* described above. A primary difference between inner tubular member *154'* and inner tubular member *154* is the inclusion of recessed portions *550* on handle *164'*. Connecting channels *552* can be relatively thin and can permit access from an exterior surface of handle *164* to an interior of recessed portions *550*. Recessed

portions 550 can receive the proximal ends of suture lines 234. For example, the proximal ends of suture lines 234 can be tied to or looped around portions 554 of handle 164'. A removable clip can be implanted using the procedure described above. Prior to removal of the deployment instrument, the suture lines 234 can be removed from portions 554 of handle 164'. Following hemostasis, the proximal ends of the suture lines 234 can be grasped to withdraw the clip from the vessel and out of the patient.

## II. METHODS OF USING AND DEPLOYING CLIPS AND/OR PLUGS

[00209] In certain embodiments, the distal end of inner tubular member can have at least one section with a larger circumferential diameter or flare to cause clip tines to deflect outward (during forward movement during deployment), capturing more tissue (than without the increased diameter section) as the clip is advanced forward, for greater tissue compression and sealing. The distal end of the inner tubular member can also have a non circumferential enlargement such as at least one bump or raised surface arranged around the circumference. This design can be used to cause only some of the clip tines to be opened or deflected outward during advancement and deployment, or some to deflect more than others.

[00210] In certain embodiments, the deployment instrument can be configured so that the clip is deployed by advancing the outer tubular member distally relative to the inner tubular member instead of by proximally withdrawing the inner tubular member. The pressure element or other pressure sensing means can be secured to the inner tubular member, such as for example at a proximal end of the inner tubular member.

[00211] In certain embodiments, suction can be used to temporarily attach the deployment instrument to the vessel wall, and/or to confirm contact with the desired tissue. The deployment instrument can be configured to enable local and/or remote suction. In certain embodiments, an elongate suction tube or lumen can be secured to and/or located within the deployment instrument. The suction tube can include an opening on or near the distal end of the deployment instrument, and a valve or fitting (such as, for example, a Luer fitting) on the side or proximal end of the tool, to which a syringe, bulb, or other suction device could be attached and/or integrally formed. In certain embodiments, local suction can be accomplished without attachment to an external vacuum source. Local suction can be accomplished, for example, using a syringe or other physician manipulated device to pull a vacuum, creating the desired suction. A Luer-lock or stopcock then can be used to close the suction tube or lumen containing the vacuum to maintain a suction condition. In certain embodiments, a remote vacuum suction system can be attached to a vacuum line. The vacuum system can include a means for limiting the amount of vacuum/suction which can be created in order to prevent trauma to the tissue adjacent to the distal suction port.

[00212] The slidable tissue cutter can be adapted to use heat to cut skin and or other tissue by making the leading edge an electrode and attaching at least one electrical conductor to the electrode. Direct resistive element heating or ohmic tissue heating can be used. Biocompatible materials (e.g., gold, platinum, platinum/iridium, stainless steel, nitinol and other suitable materials) can be used for the electrode and connected to a suitable (e.g., electrical and biocompatible) conductor. For ohmic tissue heating, one conductor can be connected to an RF power source. Another conductor is connected to a ground pad placed

on the patient's body, and also connected to the power source. For direct resistive element heating, both conductors from the power source are connected to an electrode.

[00213] In certain embodiments, the cutting elements of slidable tissue cutter can be designed to cut tissue or to both cut and remove tissue. In some cut-and-remove embodiments, the cutting element can be circular, diagonal, angled, or other blade. The slidable tissue cutter can be designed and used to cut any body tissue including, but not limited to, skin, fat ligaments, cartilage, bone, or vessels. The cutting element can be of any desirable type, including thermal (laser, RF, etc.), chemical, ultrasonic, combination, or other.

[00214] An example of a method for using deployment instrument 104 and clip 102 will now be described.

FIG. 18 illustrates a deployment instrument 104 in an initial configuration loaded onto a vascular introducer 108 that has been inserted into a patient's blood vessel 18. The deployment instrument 104 can also be configured for use with other medical devices such as, for example, tubular or elongate dilators, trocars, endoscopes, catheters, guide wires, needles, tubes, sheaths, combination or other. The tubular medical device 108 is first inserted through the inner diameter of the deployment instrument 104 which has been loaded with clip 102. The tubular medical device 108 can then be inserted through the skin and into the desired vessel 18 using any of a number of known methods, such as, for example, the Seldinger method. The desired interventional or diagnostic procedure is then performed. The deployment instrument 104 can be temporarily moved to the side as illustrated so as not to interfere with the medical procedure. For example, the deployment instrument 104 can be moved toward the back or proximal end of the introducer sheath 108 as shown in FIG. 18. Slots 162 and 170 (see FIGS. 7 and 12) facilitate this positioning.

[00215] With reference to FIGS. 19-20, deployment instrument 104 is advanced forward along the introducer sheath through the percutaneous opening 12 until the distal end 105 of the deployment instrument 104 contacts the vessel wall 16. At this state along the pressure sensitive structure on the outside of outer tubular member 156, pressure element 158 is in its initial, non-advanced configuration as shown in FIG. 20. In certain embodiments, a dilator that was previously removed or a new dilator or other elongate member can be inserted into the inner lumen of the vascular introducer 108 to provide mechanical support and resistance to kinking of the introducer 108. Reinsertion of the dilator may thus facilitate the advancement of deployment instrument 104 over the introducer 108.

[00216] With reference to FIGS. 21-22, pressure element 158 is then manually advanced distally until it reaches stop 182, indicating to the medical professional that appropriate force is being applied between the deployment instrument 104 and the vessel wall 16 to begin deployment. FIG. 22 is a close up view of the pressure element 158 in its fully advanced configuration. As the pressure element 158 is advanced distally, flexible tabs 188 are subjected to greater flexion as they advance up pressure tapers 178. Thus, advancing the pressure element 158 can require an increasing amount of applied force. Pressure tapers 178 generally flare outward until reaching flat surfaces 180. Stop 182 generally prevents pressure element 158 from advancing distally beyond this point. The amount of applied force required to fully advance the pressure element 158 can be adjusted by altering one or more of the number, size, width and rigidity of tabs 188, the angle of incline of pressure tapers 178 and the height of surfaces 180. In certain embodiments, the deployment instrument 104

can require at least about 10 ounces of force to safely begin deployment of the clip **102**. Thus, in certain embodiments, pressure element **158** can require at least about 10 ounces of force to be fully advanced. In other embodiments, the deployment instrument **104** can require between about 3 ounces of force and about 64 ounces of force to safely begin deployment of the clip **102**. In some embodiments, less than about 3 ounces of force is required. In other embodiments, the deployment instrument **104** can require about 3 ounces of force, about 4 ounces of force, 5 ounces of force, about 6 ounces of force, about 7 ounces of force, about 8 ounces of force, about 9 ounces of force, about 10 ounces of force, about 11 ounces of force, about 12 ounces of force, about 13 ounces of force, about 14 ounces of force, about 15 ounces of force, about 16 ounces of force, about 17 ounces of force, about 18 ounces of force, about 19 ounces of force, about 20 ounces of force, about 21 ounces of force, about 22 ounces of force, about 23 ounces of force, about 24 ounces of force, about 25 ounces of force, about 26 ounces of force, about 27 ounces of force, about 28 ounces of force, about 29 ounces of force, about 30 ounces of force, about 31 ounces of force, about 32 ounces of force, about 33 ounces of force, about 34 ounces of force, about 35 ounces of force, about 36 ounces of force, about 37 ounces of force, about 38 ounces of force, about 39 ounces of force, about 40 ounces of force, about 41 ounces of force, about 42 ounces of force, about 43 ounces of force, about 44 ounces of force, about 45 ounces of force, about 46 ounces of force, about 47 ounces of force, about 48 ounces of force, about 49 ounces of force, about 50 ounces of force, about 51 ounces of force, about 52 ounces of force, about 53 ounces of force, about 54 ounces of force, about 55 ounces of force, about 56 ounces of force, about 57 ounces of force, about 58 ounces of force, about 59 ounces of force, about 60 ounces of force, about 61 ounces of force, about 62 ounces of force, about 63 ounces of force, or about 64 ounces of force, or any value up to about 100 ounces, or any value therein, measured to a value of about 100<sup>th</sup> of an ounce, to safely begin deployment of the clip **102**. In certain embodiments, the deployment instrument can be configured to make an audible "click" or otherwise produce an audio, visual, or tactile signal when the pressure element **158** has fully advanced.

[00217] In some embodiments, other pressure-sensitive structures such as a pressure or force gauge can be used to verify that adequate pressure is applied. The deployment instrument can use a spring in place of, or in addition to, a taper element. A first end of the spring can be secured to a slidable element. A second end can be attached to a distal point on the outer tubular member. The slidable element can be used to compress the spring, thus applying force to the outer tubular member. A combination or other means to confirm sufficient contact and pressure between the deployment instrument and vessel can also be included. In certain embodiments, the deployment instrument can include a grasping tool configured to assist in securing the distal end of the deployment instrument to the vessel. In certain embodiments, the medical professional can observe a backflow of blood through a channel or window in the deployment instrument following removal of the tubular medical device to confirm proper placement on the vessel. Blood can be configured to flow through the central channel of the deployment instrument. In certain embodiments, a clear channel or clear tubular section **640** can be provided to receive blood flow. One or more sensors can be provided to verify proper placement and/or pressure.

**[00218]** FIG. 23 shows the deployment instrument 104 with clip 102 in a partially-deployed configuration. In a partially-deployed state, tines 126a, 126b can pierce the vessel wall 16 and the clip 102 remains attached to the deployment instrument 104 in a substantially open configuration. The medical professional partially deploys the clip 102 by beginning to withdraw inner tubular member 154. The medical professional can maintain adequate pressure on pressure element 158 (e.g. pressure sufficient to maintain pressure element 158 in its fully advanced configuration) while withdrawing inner tubular member 154. Handle 164 can be used to withdraw the inner tubular member 154. For example, the medical professional can apply distally-directed pressure to the pressure element 158 with one hand while partially withdrawing handle 164 with the remaining hand. The ledge or countersink 174 on outer tubular member 156 prevents clip 102 from being withdrawn along with the inner tubular member 154. Thus, as the inner tubular member 154 is withdrawn, the tines 126a,b begin to extend beyond the distal end 165 of inner tubular member 154. The continued application of pressure on pressure element 158 (and thus outer tubular member 156) generally forces the tines 126a,b to pierce the vessel wall 16. In certain embodiments, the pressure element 158 can include a means to prevent inner tubular member 154 from being withdrawn unless and until pressure element 158 is fully advanced.

**[00219]** FIGS. 24-29 illustrate an example of a method of producing partial deployment. FIG. 24 shows a perspective view of the deployment instrument 104 in a partially-deployed state, and FIG. 25 shows a close-up view of the distal end 105 of the deployment instrument 104 in its partially-deployed state. Handle 164 can be withdrawn until the proximal face 167 of handle 164 contacts the stops 175, generally arresting further withdrawal as shown in FIGS. 26 and 27. Stops 175 generally prevent the medical professional from fully deploying the clip prematurely and ensure the clip 102 is partially deployed to an appropriate depth. Stop 175 is configured to allow the handle 164 to travel a known, limited distance 179. In embodiments where the tips 127a,b of tines 126a,b are initially aligned with distal end 165 of inner tubular member 154, distance 179 can correspond to a depth of the tines' insertion into the vessel wall 16. In certain embodiments, distance 179 can be greater than or equal to about 0.5 mm and/or less than or equal to about 4 mm. In certain embodiments, distance 179 can be about 0.5 mm, 0.6 mm, 0.7 mm, 0.8 mm, 0.9 mm, 1.0 mm, 1.1 mm, 1.2 mm, 1.3 mm, 1.4 mm, 1.5 mm, 1.6 mm, 1.7 mm, 1.8 mm, 1.9 mm, 2.0 mm, 2.1 mm, 2.2 mm, 2.3 mm, 2.4 mm, 2.5 mm, 2.6 mm, 2.7 mm, 2.8 mm, 2.9 mm, 3.0 mm, 3.1 mm, 3.2 mm, 3.3 mm, 3.4 mm, 3.5 mm, 3.6 mm, 3.7 mm, 3.8 mm, 3.9 mm, or 4.0 mm or any size therein to about the 100<sup>th</sup> of a mm. In certain embodiments, distance 179 can be about 2 mm. Other suitable distances can also be used. Distance 179 can be different depending on the specific application or clip being used.

**[00220]** With the clip 102 partially deployed in the vessel wall 16, the tubular medical device 108 is no longer needed to guide the deployment instrument 104 to the arteriotomy and hence the tubular medical device 108 can then be removed from the vessel 18 as shown in FIG. 28. Removing the tubular medical device 108 prior to full deployment prevents the clip 102 from closing over the tubular medical device 108. Partially deploying the clip 102 helps to position the deployment instrument 104 more accurately and temporarily secure it in place while the tubular medical device 108 is removed.

[00221] Once the tubular medical device *108* is removed from the vessel, the stops *175* can be overcome by bending tab *172* in the direction of the arrow *189* shown in FIG. 29 to allow full linear movement of the inner tubular member *154*. Tab *172* can thus operate as a releasing element, permitting the stops *175* to be overcome. Recessed or weakened portion *186* of tab *172* may facilitate bending. The flattened bottom portion and angled faces *352* of handle *164* can reduce the amount that tab *172* is required to bend in order to overcome stops *175*. In some embodiments where deployment instrument *104* is disposable and configured for one-time use, tab *175* may be configured to snap off. Other appropriate stop means and methods for overcoming the stop means can be used.

[00222] With reference to FIGS. 30-31, the medical professional then continues to withdraw inner tubular member *154* until the clip *102* is forced off of or advanced past the distal end *105* of the deployment instrument *104*. The opposed fingers *122*, *124* of the clip *102* fold inwardly, drawing together sides of the vessel tissue from an outside surface of the vessel to close the arteriotomy *14* as shown in FIG. 31. Closing the arteriotomy can, but does not necessarily, result in complete mechanical closure of the opening. Instead, the term "close" in this context can refer to any facilitation of hemostasis. Thus, in certain embodiments, sides of the vessel tissue may not necessarily touch. Generally, the sides of the vessel tissue are brought closer together to reduce the size of the opening *14* in the vessel *18* and thereby facilitate hemostasis.

[00223] FIG. 32 shows the deployment instrument *104* being withdrawn following successful deployment of the clip *102*. Clip *102* can be biocompatible and configured for permanent implantation. Accordingly, in certain embodiments a patient may be discharged following confirmation of successful clip deployment and hemostasis.

[00224] In some embodiments, vascular closure system *100* can be completely or substantially extravascular in that the deployment instrument or closure device is not required to penetrate into the interior region of blood vessel *18*. This can reduce or eliminate the amount of foreign material introduced into contact with the patient's blood stream, thus reducing the risk of infection, blockage, or other complications. For example, in certain embodiments a posterior support is not required during deployment of the clip. In some systems, the use of posterior support may disadvantageously require that a portion of the deployment tool or closure device be positioned in the blood vessel during or following deployment. The use of a posterior support element within the vessel may require complicated mechanisms to facilitate its removal following deployment. The safe deployment of the clip without requiring posterior support can be facilitated through use of a partial deployment technique as described above and by the application of a controlled amount of external pressure via a pressure element or other pressure sensing means. In addition, the use of a clip with appropriately-sized tines to prevent over-insertion can also facilitate deployment without posterior support.

[00225] The system *100* described above can also be compatible with standard commercially available introducers already used in standard vascular interventional or diagnostic procedures. This can eliminate the need to purchase and use specialized and costly additional or different equipment or to change the way that the interventional or diagnostic procedures are performed, thus reducing the accompanying risks.

[00226] FIGS. 33-35 illustrate an example of a method of temporarily implanting a clip 102. In certain embodiments, a vessel closure clip 102 can be removable and configured for temporary implantation as illustrated in FIG. 33. In embodiments using temporary closure, one or more suture lines 234 or other suitable tethering means can be secured to the clip 102 and positioned along the outer surface of the outer tubular member 156 prior to insertion. The suture lines 234 can be tied to the clip 102 or looped through window portions 125 or other openings provided on the clip 102 for this purpose or attached in some other way. In certain embodiments, the clip 102 and deployment instrument 104 may be provided to the medical professional with suture lines 234 attached. In other embodiments, suture lines 234 may be attached by the medical professional prior to use. Slots 176 on the distal end 173 of outer tubular member 156 (see FIG. 8) can facilitate access to the clip 102 for the purposes of securing the suture lines 234 to the clip 102 after it is loaded onto the deployment instrument 104. The distal ends of axial grooves 160 on inner tubular member 154 can allow the suture lines to be passed under base portion 120. In certain embodiments, the suture lines 234 can be tied or secured to the clip before it is loaded on the deployment instrument 104. The suture lines 234 can run along the outer surface of outer tubular member 156 as shown in FIG. 33. In other embodiments, the suture lines 234 can run along an interior of the deployment instrument 104. In certain embodiments, the deployment instrument 104 can include channels specifically adapted to accommodate suture lines 234.

[00227] The removable clip 102 can be temporarily implanted using the procedure outlined above. The proximal ends of the suture lines 234 can be left extending outside of the patient's body while the clip 102 remains implanted. After a period of time sufficient to achieve hemostasis, the medical professional can pull on the suture lines 234 to remove the clip as seen in FIG. 35. The closure force of the clip can be configured so that force applied to the suture lines 234 causes the fingers 122, 124 to temporarily open, allowing the clip 102 to be safely removed without reopening the arteriotomy 14 or damaging the vessel wall 16. In certain embodiments, the clip 102 can include another or alternative release mechanism that can be triggered via the suture lines 234. The release mechanism can cause the fingers 122, 124 to open to facilitate removal of the clip 102. In embodiments using a shape memory clip, the clip can be cooled until it transforms to its martensite phase, making it more easily deformed and lowering the amount of force required to open the clip's fingers and withdraw it. The clip 102 can be cooled via insertion of a cold probe or via application of an externally-applied cold source such as an ice pack. In addition or in the alternative, an infusing syringe can be used to deliver a cooled liquid such as chilled saline to the clip. In certain embodiments, the clip 102 can exhibit a two-way shape memory effect and cooling the clip 102 can return it to its second memorized configuration which can be, for example, an open configuration. The clip's composition and treatment can be selected to achieve desired phase transition temperatures to facilitate such an approach.

[00228] The time required to achieve hemostasis can vary from patient to patient depending on a variety of factors including the patient's age, sex, medical condition, medications, and the presence of anti-clotting agents that can have been used during the medical procedure. Under certain conditions, clip 102 can be removed after about 10 minutes, after about 15 minutes, after about 20 minutes, after about 25 minutes, after about 30 minutes, after about 35 minutes, after about 40 minutes, after about 45 minutes, after about 50

minutes, after about 55 minutes, or after about 60 minutes or any suitable time therein measured to about 100<sup>th</sup> of a second. In some embodiments, clip **102** can be removed after about 1 h or more. Other suitable times can also be used.

**[00229]** In some embodiments, it can be desirable to use suture lines **234** even in clips intended for permanent implantation in order to enable emergency removal. In this arrangement, the medical professional can deploy the clip using the procedure described above. Once it is determined that the clip has been successfully deployed, the medical professional can cut the suture lines **234** and completely withdraw them from around the clip.

**[00230]** This disclosure has provided certain examples of closure devices including clips and plugs. However, other types of closure devices can be used. In certain embodiments, a closure device can be smaller in an initial configuration or in a deployed configuration. In certain embodiments, the closure device can close a tissue opening by bringing closer together sides of the tissue opening and/or by partially or completely occluding the opening. The closure device can be partially or completely made from one or more of a polymer, rubber, silicone, metal, metal alloy, superelastic / shape memory polymers and metallic alloys, combination or other suitable material or materials.

**[00231]** In some embodiments, the closure device may be partially or completely fabricated from a biodegradable/bioabsorbable material, including but not limited to one or more of synthetic materials, including (but not limited to): polyglycolide, polylactide, polycaprolactone, polytrimethylene carbonate, polypara-dioxanone, combinations thereof, or other suitable materials, such as a copolymer between caprolactone, glycolide, lactide, or trimethylene carbonate; natural materials, including (but not limited to): alginates, chitosan, collagen, fibrin, fibrinogen, hyaluronic acid, hyaluronic acid, combination thereof, or other suitable materials; starch, modified cellulose, collagen, fibrin, fibrinogen, fibronectin, elastin, vitronectin, laminin, thrombin, albumin and gelatin or other connective proteins or natural materials, polymers or copolymers such as polyvinyl pyrrolidone, polylactide [poly-L-lactide (PLLA), poly-D-lactide (PDLA)], polyglycolide, polydioxanone, polycaprolactone, polygluconate, polylactic acid (PLA), polylactic acid-polyethylene oxide copolymers, poly(hydroxybutyrate), polyanhydride, polyphosphoester, poly(amino acids), poly(alpha-hydroxy acid) poly d,l-lactic acid (PLA) and copolymers of lactic acid and glycolic acid (PLGA), or related copolymers of these materials as well as composites and combinations thereof and combinations of other biodegradable/bioabsorbable materials. In some embodiments, the closure device can be partially or completely fabricated from a biocompatible material, such as expanded polytetrafluoroethylene (ePTFE), polyester, polyurethane, silicone, rubber, Dacron, and/or urethane.

**[00232]** In some embodiments, the closure device can include one or more coatings and/or be partially or completely formed from one or more of the following: swellable materials, bioabsorbable materials, and biocompatible materials.

**[00233]** In some embodiments, the closure device can have a biocompatible contact surface such as adhesives, bonding compounds, or other solutions, including those intended to delay swelling or expansion of at least one section of the closure device once it comes in contact with a fluid. The biocompatible contact surface can be

located on any surface or all surfaces of the closure device. The contact surface can be applied or integrated into the device in many ways, such as during the manufacturing process, just prior to deployment, or after the device has been deployed. The bonding materials can be in the form of a liquid, semi solid, or solid. Suitable bonding materials can include gels, foams and microporous mesh. Suitable adhesives can include acrylates, cyanoacrylates, epoxies, fibrin-based adhesives, other biological based adhesives, UV light and/or heat activated or other specialized adhesives. The contact surface can bond on initial contact, or after a longer period of time to allow repositioning of the closure device if desired. Such a contact surface can include a crystalline polymer that changes from a non-tacky crystalline state to an adhesive gel state, such as when the temperature is raised from room temperature to body temperature. An example of such material is available under the trade name Intillemer™ adhesive, available from Landec Corp., as well as composites and combinations thereof and combinations of other materials. Suppliers of biocompatible adhesives include, but are not limited to, Plasto (Dijon, France), Haemacure (Montreal, Canada), Cohesion (Palo Alto, Calif.), Cryolife (Kennesaw, Ga.), TissueLink (Dover, N.H.), and others. To increase the work time of the contact surface and/or to allow repositioning of the closure device after it has been deployed, the contact surface can be blended with a material such as a starch or other material, that retards or delays bonding to allow repositioning of the device after it has been deployed. A degradable coating can be placed over the contact surface so that it degrades and exposes the adhesive. Other contact surfaces can include composites-based adherents and combinations of the above materials and other suitable materials as are known in the art.

**[00234]** In some embodiments, the closure device may break down by hydrolysis, resorption, a combination thereof, or another suitable method or process.

**[00235]** The closure devices, systems, and methods can be used for any suitable cardiovascular, gastrointestinal, neurological, reproductive, lymphatic, respiratory, orthopedic, combination or other applications where partial or complete, temporary, removable, or permanent closure, compression, sealing, bringing together, cinching, anchoring, and/or reinforcement, tissue modification, stabilization, a shim, tissue access, tissue reforming, tissue connection (e.g., to other tissue or between tissue and a medical device), tissue displacement, and/or tissue resizing is desired. Additionally, the closure devices, systems, and methods can be used in connection with any lumen, duct, organ, hollow body organ or cavity, or other bodily structures or tissues, where partial or complete, temporary, removable, or permanent sealing, crimping, compression, plugging, reinforcement, combination or other purpose is desired. For example, some applications include, but are not limited to, the following: cerebral aneurysm treatment, shortening the chordae tendinae to treat mitral valve prolapse, reversible or permanent sterilization for women by occluding the fallopian tubes, and for men by occluding the vas ducts or tubes, closure of septal (or other) defects in the heart or anywhere else in the body, patent foramen ovale (PFO) closure, post-biopsy tissue closure, tissue closure following minimally invasive surgical or transluminal procedures, general tissue ligation, and localized therapeutic elution. Other applications include closing an access puncture of the heart following a diagnostic or interventional procedure, such as, for example, minimally invasive, percutaneous heart valve reinforcement or replacement procedures using devices and systems such as those from Edwards Lifesciences (Irvine, CA).

[00236] For some applications and utilities of the disclosed technology, it may be advantageous to have the plug / sealing element fabricated from a biocompatible material, or a material coated and or covered with a biocompatible material, that does not bioabsorb or biodegrade, or may bioabsorb, biodegrade, break down, after implantation in or on the body. A few examples of utilities and applications utilizing a non-absorbable plug / sealing elements, include, but aren't limited to, at least one of the disclosed device, system and or method configured for a cerebral aneurysm treatment (for example, deploying a plug / sealing element and occluding all or part of the blood flow in the vessel, proximal to the aneurysm), shortening the chordae tendinae to treat mitral valve prolapse, reversible or permanent sterilization for women by occluding the fallopian tubes, and for men by occluding the vas ducts or tubes, closure of septal (or other) defects in the heart or anywhere else in the body, patent foramen ovale (PFO) closure, post-biopsy tissue closure, tissue closure following open field surgical procedures, minimally invasive surgical, percutaneous, transluminal procedures, general tissue ligation, and localized therapeutic elution. Other applications include closing an access puncture of the heart following a diagnostic and / or interventional procedure.

[00237] For example, a system may be configured to deploy an implant for localized elution of a therapeutic agent or material. The implant may be removable or permanent, and made at least partially of a bioabsorbable/biodegradable, or non-degradable/absorbable material.

[00238] A tissue closure system can enable the advancement / deployment of the sealing element over and/or alongside other than tubular medical devices, including tools used during medical procedure such as, for example, hemostats, cutters, tweezers, probes, biopsy devices, etc. A deployment instrument and/or sealing element can be configured to be advanced over and/or alongside additional medical devices, such as, for example, needles, hypo tubes, guide wires, electrode wires, intravenous (IV) tubes, vascular introducers, catheters, laparoscopes, endoscopes, trocars, cannulas, combination or other suitable medical devices. The disclosed systems can be packaged on or with the medical devices or tools. A deployment instrument and/or sealing element can be configured to work with medical devices of all sizes, including devices having an outer diameter of less than or equal to about 6 French, greater than or equal to about 20 French, and all sizes in between. In some embodiments, a deployment instrument and/or sealing element can be configured to work with medical devices having an outer diameter of about 6 French, 7 French, 8 French, 9 French, 10 French, 11 French, 12 French, 13 French, 14 French, 15 French, 16 French, 17 French, 18 French, 19 French or 20 French. Other suitable sizes may also be used.

[00239] In certain embodiments, a tissue closure system can be configured to operate as a stand-alone surgical system. For example, in certain embodiments a tissue closure system can be configured to operate without being advanced over or alongside or otherwise being guided by an elongate medical device.

[00240] A deployed element can be used as a temporary or permanent spacer, shim, or to displace and/or support, stabilize, reinforce, or occlude any tissue or tissues, including bone. The deployed element can be partially or completely made from many different types of materials, including, for example, a polymer, sponge, metal, metal alloy, superelastic / shape memory materials (including polymers and metallic alloys), or any other suitable material or materials. The deployed element can be deployed through a tube with a pusher

element, e.g., a stylet, plunger, inner tubular member or rod, and allowed to expand before, during and/or after deployment. The deployment element can be biased in an expanded configuration. The deployed element can be maintained in a compressed configuration during positioning of the element, and allowed to expand to an expanded configuration when no longer constrained. In general, the closure device may be constrained in a smaller cross section profile, and allowed to self-expand once a constraining force is removed. In addition, the closure device may be constrained in an open position, and allowed to self-close once the opening force is removed.

[00241] The general components and/or disclosed systems, with desired modifications, can be used to temporarily or permanently close, and/or reinforce tissue access for medical procedures such as minimally invasive biopsy, other tissue removal, or diagnostic or therapeutic procedures including locations on, through, or inside the heart, locations for procedures including electrophysiology, congestive heart failure, valve related treatment (including, for example, dilation, valve reinforcement, replacement, papillary muscle treatment, chordae tendineae, and other related structures, combination and or other purposes) and/or any other locations on organs or tissue, including skin.

[00242] The systems of the present invention can facilitate less invasive surgery involving thorascopic access and visualization to the target location. In some embodiments, the systems of the invention can be suitable for use through a median sternotomy, lateral thoracotomy, intercostals port-access, mini-sternotomies, other less invasive approaches involving xiphoid access, inguinal approaches, or sub-thoracic approaches adjacent the diaphragm. In other embodiments, the systems of the present invention can be configured for catheter-based applications by elongating the shaft and altering the diameters and other feature dimensions for intravascular access.

[00243] The systems of the present invention are capable of being deployed through a thoracostomy, thoracotomy, median sternotomy, mini-sternotomy, mini-thoracotomy, xiphoid access, subthoracic access, arthroscopic, or laparoscopic approach, thereby potentially eliminating the need for long incisions to access the soft tissue and corresponding anatomic structures.

[00244] The closure devices, systems and methods can be used for temporary or permanent tissue reshaping, reforming and/or resizing. Tissues which can be reshaped and/or resized include organs, such as the stomach, lungs, etc., and other structures, such as the esophagus and structures of the heart and/or valves. For example, in certain embodiments one or more clips may alone be sufficient to reshape, reform and/or resize tissue by one or more of accessing, gathering, pursing, bunching, cinching or holding tissue. In other embodiments, multiple clips can be connected together by a suitable tether, e.g., static or elastic, from the outer or inner surface of a tissue structure or organ. In certain embodiments, the tether can be tightened following implantation of the clips to achieve additional resizing, reforming and/or reshaping of tissue. In certain embodiments, one or more clips and/or a suitable tether can be used to resize and/or reinforce the Lower Esophageal Sphincter (LES) for gastrointestinal uses, or to resize the tissue around a heart valve.

[00245] The disclosed clips and/or delivery systems can also be configured to anchor implanted stent grafts by securing the graft to the tissue wall to prevent the graft from moving. For example, stent grafts (such as those

devices and systems from W.L. Gore, Cook, Medtronic, etc.) can be used to treat an abdominal aortic aneurysm by reinforcing the aortic wall to prevent rupture. One or more clips can be deployed on the inside of the stent graft and/or on the outside of the abdominal aorta, and may be in contact with the graft and/or act to limit potential graft movement. The disclosed devices, systems and methods relating to anchoring or attachment of stent grafts, endoprosthesis, or other structures or devices, can also be used for any other locations on or inside the body.

[00246] The general closure systems can be configured to be used with robotically or computer controlled medical procedures, including surgical systems such as those available from Intuitive Surgical, Inc. (Sunnyvale, CA), and catheter-based technologies from Stereotaxis (St. Louis, MO) and Hansen Medical (Mountain View, CA).

[00247] The closure systems can be used to close the vessel access in larger sized catheter-based percutaneous, transluminal procedures, including heart valve reinforcement / replacement procedures, such as those from CoreValve (Irvine, CA), Edwards Lifesciences (Irvine, CA), Sadra Medical Inc. (Campbell, CA), etc.

[00248] As shown in further detail in FIGS. 90A-E with respect to deployment of the plug device from the capsule 630 having a hemostatic design, the plug sits within a capsule 630 that is positioned between an introducer and a guide seal assembly as previously shown. Looking down the barrel of the capsule 630 from the distal end 80, FIG. 90B, the walls of the capsule 630 can be seen with the positioned plug down within the aperture. A skirt area of the plug covers a bore and hemostatic pressure forces the skirt face to seal against the housing thus creating a seal which prevents leakage of fluid through the capsule 630 as shown in FIGS. 90C-E. In operation, the introducer is advanced to the site in vivo where the plug is to be deployed. A plunger is then advanced in a distal direction through the plunger stem, capsule body 634 and introducer pushing the plug through the introducer to the site as shown in FIG. 91A.

[00249] To assist in controlling the direction of travel of the plunger grip, a locking split bushing can be incorporated in the design as shown in FIGS. 91B-I. The conical split bushing configuration has a conical taper on the stem and a split conical bushing which engages the conical taper and causes self-locking when backward (proximally directed) motion is attempted, but releases moving forward (distally directed). In another configuration, a canted disk which locks and releases can be used as shown in FIGS. 91D-E. As the disk tilts back and forth it either allows movement of the stem in a forward directed or locks the stem to prevent backward motion. Still another configuration is a ratchet configuration as shown in FIGS. 91F-G where the stem is notched and engages locking fingers which allow forward direction but prevent backward direction. Yet another configuration uses a silent ratchet as shown in FIGS. 91H-I where fingers are provided that dig into the stem.

[00250] As shown in FIGS. 92A-T the introducer is advanced into the vessel such that the tip of the introducer crosses the vessel wall and the distal end 80 of the introducer is positioned within the lumen of the vessel. As shown in FIGS. 92A-B the hemostasis valve is closed and keeps the sealing device in place within the capsule 630. Once the introducer is positioned at a desired location crossing, for example, the vessel wall the plunger is inserted into the proximal opening of the capsule 630 at the introducer cap as shown in FIGS. 92C-

D. As the plunger is advanced through the capsule **630**, the plunger tube comes into contact with the tether, a collet insert and the collet which places a slight drag on the plunger to allow forward motion but not backward motion. The collet can be configured from a helically wound braid or a biaxial braid which results in relaxation when the plunger is pushed through it but tightens to prevent backward motion when the plunger is retracted by reducing the radial distance between opposing sides and the overall circumference or a collar around the plunger such that it exerts a strong clamping force when it is tightened via a tapered outer collar, as shown here. The plunger and cartridge is then inserted into the proximal end **70** of the introducer as shown in **FIGS. 92E-F**. The combination is then advanced into the introducer and seated within the introducer as shown in **FIGS. 92G-H** and the hemostasis valve is in an opened configuration. From that point the plunger is advanced within the collet advancing the plug forward (still in the capsule **630**) as shown in **FIGS. 92I-J**. The plunger is then advanced further into the introducer pushing the plug into the inner lumen of the introducer device as shown in **FIGS. 92K-L**. At this point, the side wings of the plug are bent backwards so that the plug assumes a smaller cross-sectional profile configuration having an outer diameter less than the interior diameter of the introducer while advancing through the introducer device. As shown in **FIGS. 92M-N** the plug is now advanced approximately 80% through the introducer toward the distal end **80** of the introducer (which is positioned within the lumen of the vessel). The plug is then advanced beyond the distal end **80** of the introducer at which point the plug is no longer constrained and restores to its original profile with a diameter of the distal end **80** of the plug being greater than the diameter of the introducer as shown in **FIGS. 92O-P**. Thereafter the introducer is withdrawn. As the introducer is withdrawn, the plug is pulled into a position wherein the stem of the plug traverses the vessel wall opening and the plug face conformably engages the interior of the vessel wall. Once the introducer exits the vessel, the proximal end **70** of the plug stem is observable from the exterior of the vessel and may, in some configurations, extend beyond the interior surface of the vessel wall as shown in **FIGS. 92Q-R**. Additional close up detail of the plug being positioned within the vessel is shown in **FIGS. 92S-T**. If a tether has been used the tether extends from the plug enabling the user to ensure that the stem of the plug is properly advanced through the opening of the vessel wall. The tether can then be removed, if desired. Alternatively, the tether may be left within the body if desired. For example, the tether may be made of a biodegradable/bioabsorbable material and left in the body, and the proximal end of the tether may be cut flush with the skin. The plug is held securely in place by the interior fluid pressure forcing the inner distal surface of the plug against the interior vessel wall. This force proportionally increases with fluid pressure, improving the security of the plug. No other features are required to achieve hemostasis of the plug. The function of the stem is essentially three fold. First, it brings the inner vessel contacting element in contact with the inner wall of the vessel, creating a momentary hemostasis that is then self activated. Second, it acts as a centering element to center the vessel contacting about the puncture site (e.g., where the stem is positioned at a central point and not positioned off-center). Lastly, it prevents the plug from shifting away from the puncture site due to the force exerted by the blood flow through the vessel. A simple stem configuration can be as illustrated in **FIGS. 85A-B**.

[00251] FIG. 96 shows vascular access closures. In some embodiments, vascular access closures 960 may be provided without a tether. In other embodiments, vascular access closures 960 may be provided with a tether 962, which may or may not be a removable tether. The closure device 960 may have a skirt 964, which may function as a sealing surface. The closure device may also have a stem 966. In some embodiments, the closure device 960 may have one or more ribs 968 or protrusions. The closure device may have any configuration of a clip, plug, or closure device as discussed elsewhere herein.

[00252] A closure device may penetrate an artery 970. In some embodiments, the closure device may be used to close a puncture site 972 in the artery. The artery may have a fluid pressure therein 974, which may keep the closure device 960 in place. In some embodiments, a skin surface 976 may be provided adjacent to or in the proximity of the artery 970, and may have an existing puncture site 972. The closure device 960 may be provided so that the skirt 964 is within the artery 970, and the stem 966 extends into the existing puncture site 972. In some embodiments, a tether 962 may be provided, extending through the existing puncture site 972.

[00253] FIGS. 97A-E show steps that may be used to deliver a removable vascular access closure with the additional ability to reaccess the existing puncture site. FIGS. 97A shows a first step, where a closure device 980 may be used to close a puncture site 985. The closure device 980 may have a stem 982. The closure device 980 may be connected to a tether 983. In some embodiments, at least part of the tether 983 may be within, adjacent to, or proximate to a tether guided re-dialator 984. In some embodiments, the re-dialator 984 may surround at least a portion of the tether 983. The re-dialator 984 may slide along the tether 983 and reach the stem 982 of the closure device 980. In some embodiments, the re-dialator 984 may enter the puncture 985 before reaching the stem 982 of the closure device 980. In some embodiments, as shown in A1, the re-dialator 984 may narrow at its distal tip. In other embodiments, as shown in A2, the re-dialator 984 may widen at its distal tip.

[00254] The re-dialator 984 may stop at the stem 982 of the closure device 980, as shown in option A. In other embodiments, as shown in option B, the re-dialator 984 may extend over the stem 982 of the closure device 980. The dialator tip 984 may be expanded up over the stem 982.

[00255] FIGS. 97B shows a second step, where a re-dialator 984 may be pushed into a vessel 986, such as an artery, and may be used to unseat the closure device 980. The re-dialator 984 may push the closure device 980 into the vessel 986. The tether 983 may still be attached to the stem 982 of the closure device 980. The tether 983 may be within, adjacent to, or proximate to the re-dialator 984.

[00256] FIGS. 97C shows a third step, showing an unseated closure device 980, such as a plug, within a vessel 986, while the re-dialator 984 is shown penetrating the vessel wall and extending into the vessel. A tether 983 connected to the unseated closure device 980 may extend through the dialator 984. An introducer sheath 988 of an introducer 987 may be slipped over the dialator 984. The introducer sheath 988 may surround, be adjacent to, or be proximate to at least a portion of the tether 983.

[00257] FIGS. 97D shows a fourth step, where an introducer sheath 988 may be pushed all the way into a vessel 986, such as an artery. The introducer sheath 988 may be pushed until the dialator 984 protrudes from the introducer sheath 988. The dialator 984 may be pulled on until the closure device 980 collapses all of the

way into the introducer tip **988**. The dialator **984** may be continued to be pulled until the closure device **980**, tether **983**, and dialator **984** are completely extracted from the introducer **987**.

[00258] FIGS. 97E shows various optional configurations. For example, as shown in A, an extra-long tether **983** may be provided, along with a pre-installed dialator **984** and introducer **987**. The tether **983** may be fed through the full length of the long dialator **984**. The pre-installed dialator **984** may be longer than the introducer **987**. The dialator **984** may be pulled through the introducer **987**. In some embodiments, the dialator **984** may be pulled along with the tether **983** and closure device **980**.

[00259] As shown in B, a dialator **984** may be provided with a snap-end **990**. The dialator **984** may be within an introducer **987** and may protrude from an introducer sheath **988**. In some embodiments, the dialator **984** may have a snap-end **990** at a proximal end, and a dialator grabber **989** may extend entirely through the introducer **987**, so that a grabber **989** protrudes from a proximal end of the introducer **987**, and the grabber **989** has a snap-end **991** at a distal end of the grabber. The introducer sheath **988** and dialator grabber **989** may slide over a tether **983** and slide toward the dialator **984**. The distal end of the grabber **989** with the snap-end **991**, may snap into place against proximal snap-end **990** of the dialator **984**. The introducer sheath **988** may slide over the dialator/grabber interface and over at least a portion of the dialator **984**. In some embodiments, the dialator grabber **989** may be pulled through the introducer **987**. In some embodiments, the grabber **989** may be pulled along with the dialator **984**, tether **983**, and closure device **980**.

### III. Methods of Manufacture

[00260] The deployment instrument **104** can be partially or completely made from one or more of the following materials: polymers, including Nylon, polyamide, polycarbonate (e.g., Makrolon®), acrylonitrile butadiene styrene (ABS), polyester, polyethyleneterephthalate (PET), polyetheretherketone (PEEK™), polyimide, superelastic / shape memory polymers and metals, including spring steel, stainless steel, shape memory metal alloys including nickel titanium alloys (Nitinol), 17-7 PH, cobalt-chromium-nickel alloy (Elgiloy®), and nickel based alloys with chromium and iron (Inconel®). Other suitable materials can be used.

The deployment instrument **104** can be completely or partially fabricated using one or more of the following methods: casting, extrusion, laminating, machining, molding (injection or other), sintering, or stereo lithography. Other suitable methods can be used.

[00261] As illustrated, in certain embodiments, the deployment instrument **104** can be constructed using relatively few components, e.g., an inner tubular member, an outer tubular member, and a pressure element.

Each of the components can be produced inexpensively via injection molding. In certain embodiments, the deployment instrument **104** can be disposable and designed for single use. Alternatively, the deployment instrument **104** can be designed for repeated use following sterilization.

[00262] In certain embodiments the advancement / deployment tool can contain more than one clip, with the ability to deploy one or more clips at a time, and can include an indexing or other means to controllably deploy only one (or more) clips at a time. A multiple-clip embodiment can include at least two or more of the clips tethered together with a suitable tether. The tether can be elastic and/or able to be tensioned or otherwise configured to permit tissue between the two or more deployed clips to be pursed as the deployed clips are

pulled (or drawn) towards one another. The tether can be permanently or temporarily tightened and secured at, for example, one or more ends of the tether to maintain the tension.

[00263] A method for loading the clip *102* onto the deployment instrument *104* will now be described with reference to FIGS. 36-39. A loading mechanism *240* can be used to facilitate loading the clip *102* onto the distal end *165* of inner tubular member *154*. Loading mechanism *240* includes a proximal section *244* which mates with the inner tubular member's inner lumen as seen in FIG. 37. Clip *102* is then advanced over tapered distal section *242* of loading mechanism *240*. Distal section *242* gradually forces apart the clip's fingers *122*, *124* as shown in FIG. 38. The loading mechanism *240* can also include an intermediate section *245* with a substantially constant circumference which can be substantially equal to that of inner tubular member *154*. A pusher mechanism *249* can be used to advance the clip over the loading mechanism *240* and onto the deployment instrument *104*. Pusher mechanism *249* can include an end geometry configured to mate with the distal end of clip *102* as seen in FIG. 39. Once the clip *102* has been fully loaded onto the deployment instrument *104*, the pusher mechanism *249* and loading mechanism *240* can be removed. In embodiments using a superelastic or shape memory clip, the clip *102* can be cooled until it undergoes a martensite phase transformation in order to facilitate the clip's deformation. During its martensite phase, the clip *102* is more easily deformed and thus the fingers *122*, *124* can be more readily spread apart in order to load the clip *102* onto the deployment instrument *104*. Such an approach can be used as an alternative to or in addition to the loading procedure described above.

[00264] Post device fabrication coating methods can include, but are not limited to, spin coating, RF-plasma polymerization, dipping, spraying, brushing, submerging the devices into a beaker containing a therapeutic solution while inside a vacuum chamber to permeate the device material, combination or other suitable methods.

[00265] Alternatively, or in combination with the above therapeutic substances, one or more materials such as platinum, gold, tantalum, tin, tin-indium, zirconium, zirconium alloy, zirconium oxide, zirconium nitrate, phosphatidyl-choline, pyrolytic carbon, combination or other material, can be deposited onto the closure device surface using electroplating, sputtering vacuum evaporation, ion assisted beam deposition, vapor deposition, silver doping, boronation techniques, or other coating process.

[00266] Radiopaque material such as barium sulfate, bismuth trioxide, tantalum, platinum/iridium or other suitable materials can be added to any of the closure devices for enhanced visualization under a fluoroscope or other visualization means commonly used in a catheterization lab or surgical suite. Additionally, such materials can be added to the closure device by sputter coating, ion deposition, vapor deposition, combination, or other suitable processes.

[00267] In certain embodiments, the clip can be configured to be in its malleable martensite phase at room temperature. The clip can be loaded onto a deployment instrument in an open configuration. The clip can be configured to transition to an austenite phase by the application of heat during or after deployment. The application of heat can cause the clip to revert to its memorized, closed configuration. In certain embodiments, the clip can be configured to revert to its closed configuration upon being heated to a

temperature near the temperature of the human body. In such embodiments, the clip can be delivered to the arteriotomy and partially deployed or held in place on the exterior of the vessel wall *16* for a period of time sufficient to heat the clip to its austenite transition temperature. In other embodiments, heat may be applied via insertion of a heated probe or remotely via application of focused electromagnetic energy.

5 **[00268]** The clip can include at least one (single element) hinge feature to assist with deployment, tissue engagement, compression and or removal from the tissue. The clip can be partially or completely made from one or more of the following materials: superelastic / shape memory polymers, metals including, spring steel and stainless steel, metal alloys including nitinol, 17-7 PH, Elgiloy®, and Inconel®. Other appropriate materials can also be used. In a preferred embodiment, the clip can be partially or completely made from a  
10 superelastic and/or shape memory material such as nitinol. A discussion of certain properties of superelastic and/or shape memory materials can be found in U.S. Patent No. **7,182,771**, the entirety of which is hereby incorporated by reference herein and made a part of the present specification. In certain embodiments, such as those using nitinol or other superelastic and/or shape memory materials, it can be desirable for the clip to have a relatively tight bend in a memorized configuration. In some circumstances, it can be advantageous to use a  
15 bend sufficiently tight that it would normally exceed the elastic limit of the material and thus permanently deform it. To prevent permanent deformation, a bend can be produced in the device followed by an annealing process to relieve bending stresses within the device. Following this first bend, the device can be bent further to produce an even sharper bend, and then re-annealed to alleviate the stress from this additional bending. This process can be repeated to attain a desired substantial bend, or reduced radii, or reduced angle that would  
20 otherwise permanently deform the device if the bend were attempted in a single bending event. In certain embodiments, any surface of the clip that comes in contact with blood and/or tissue can be electropolished, especially metal or metal alloy surfaces, such as a superelastic/shape memory alloy. Electropolishing may be used to produce smooth surfaces. Electropolishing can also beneficially remove or reduces flash and other artifacts from the fabrication of the device.

25 **[00269]** The clip can have a completely contiguous cross section, or partial, incomplete contiguous cross section. A discontinuous cross-section can permit certain embodiments of the clips to be loaded from the side of the vascular introducer and/or deployment instrument. In certain embodiments, the deployment instrument can include a slot or opening permitting the deployment instrument to be secured to the tubular medical device from the side. Tissue engagement elements (e.g., tines, fingers, protrusions, etc.) can be parallel, overlapping,  
30 crossing, spiral, combination or other. The clip can include tissue engagement elements with the same, different or combination lengths. The clip can compress tissue on a horizontal plane, vertical plane or a combination of both. The tissue engagement elements can be straight, curved or a combination of both. The tissue attachment motion / direction can be straight, twisted, rotated, combination or other suitable and desirable motion or motions.

35 **[00270]** Many different types of delivery features can be incorporated during the manufacturing process for any of the devices and systems disclosed herein, such as coatings on the vascular closure device, can be used to deliver therapeutic agents, including (but are not limited to) one or more of the following:

antiproliferative/antimitotic agents including natural products such as vinca alkaloids (i.e. vinblastine, vincristine, and vinorelbine), paclitaxel, epididodophyllotoxins (i.e. etoposide, teniposide), antibiotics (dactinomycin (actinomycin D) daunorubicin, doxorubicin and idarubicin), anthracyclines, mitoxantrone, bleomycins, plicamycin (mithramycin) and mitomycin, enzymes (L-asparaginase which systemically  
5 metabolizes L-asparagine and deprives cells which do not have the capacity to synthesize their own asparagine); antiplatelet agents such as G(GP) II.sub.b/III.sub.a inhibitors and vitronectin receptor antagonists; antiproliferative/antimitotic alkylating agents such as nitrogen mustards (mechlorethamine, cyclophosphamide and analogs, melphalan, chlorambucil), ethylenimines and methylmelamines (hexamethylmelamine and thiotepa), alkyl sulfonates-busulfan, nirtosoureas (carmustine (BCNU) and analogs, streptozocin), trazenes—  
10 dacarbazine (DTIC); antiproliferative/antimitotic antimetabolites such as folic acid analogs (methotrexate), pyrimidine analogs (fluorouracil, floxuridine, and cytarabine), purine analogs and related inhibitors (mercaptapurine, thioguanine, pentostatin and 2-chlorodeoxyadenosine {cladribine}); platinum coordination complexes (cisplatin, carboplatin), procarbazine, hydroxyurea, mitotane, aminoglutethimide; hormones (i.e. estrogen); anticoagulants (heparin, synthetic heparin salts and other inhibitors of thrombin); fibrinolytic agents  
15 (such as tissue plasminogen activator, streptokinase and urokinase), aspirin, dipyridamole, ticlopidine, clopidogrel, abciximab; antimigratory; antisecretory (breveldin); anti-inflammatory: such as adrenocortical steroids (cortisol, cortisone, fludrocortisone, prednisone, prednisolone, 6.alpha.-methylprednisolone, triamcinolone, betamethasone, and dexamethasone), non-steroidal agents (salicylic acid derivatives i.e. aspirin; para-aminophenol derivatives i.e. acetaminophen; indole and indene acetic acids (indomethacin, sulindac, and etodalac), heteroaryl acetic acids (tolmetin, diclofenac, and ketorolac), arylpropionic acids (ibuprofen and derivatives), anthranilic acids (mefenamic acid, and meclofenamic acid), enolic acids (piroxicam, tenoxicam, phenylbutazone, and oxyphenthatrazone), nabumetone, gold compounds (auranofin, aurothioglucose, gold sodium thiomalate); immunosuppressives: (cyclosporine, tacrolimus (FK-**506**), sirolimus (rapamycin), azathioprine, mycophenolate mofetil); angiogenic agents: vascular endothelial growth  
25 factor (VEGF), fibroblast growth factor (FGF); angiotensin receptor blockers; nitric oxide donors; anti-sense oligionucleotides and combinations thereof; cell cycle inhibitors, mTOR inhibitors, and/or growth factor signal transduction kinase inhibitors. Alternatively, a clot promoter can be used, such as protamine sulphate or calcium hydroxide. Endothelial cells can also be added to the vascular closure device.

**[00271]** One or more of the therapeutic agents can be included in the device in many ways, such as by  
30 blending them into the device base materials during fabrication, applying them just prior to deployment, or applying them after the device has been deployed. One or more therapeutic agents can be used on a single device. The delivery feature can be designed to provide benefits rapidly or over an extended period of time. The delivery feature can be stable or eluting. The coatings, materials, compounds, substances, therapeutic agents, etc., can elute from a coated (or embedded) device (or component) over time and enter the surrounding  
35 tissue. In certain embodiments, the delivery feature can be effective during a period of at least about three days in some applications, between about seven and about thirty days in other application, and/or up to

approximately six months in some applications. All preferred embodiments, for example, materials, specific dimensions, are not meant to be limiting.

#### IV. KITS

[00272] A vessel closure system as described above can be sold to end users in the form of a kit. The kits can  
5 comprise multiple items, including but not limited to one or more deployment instruments and one or more clips. The kits can further comprise tissue cutters and tissue dilators as described above. In some embodiments, the kits can comprise swellable plugs in addition to or instead of the clips. The deployment instruments can be preloaded with the clips or plugs, or the kits can require assembly by the end user. In some  
10 embodiments, the kits can comprise an elongate medical device. In some embodiments, the kits can comprise one or more items selected from the group consisting of needles, hypo tubes, guidewires, electrode wires, intravenous wires, vascular introducers, catheters, laparoscopes, endoscopes, trocars, and cannulas. In some  
15 embodiments, the kits can comprise a compound for delivery to a tissue. The compound can be one or more of a sclerosing agent, an antibiotic, or an anti-inflammatory agent. In some embodiments, the kits can comprise one or more of any of a pair of scissors, a scalpel, a swab, a syringe, a hemostat, a lubricant, a  
20 needle, a snare, an antiseptic, or an anesthetic. Components of the kits can be designed and intended for single or multiple uses.

[00273] Kits can be configured such that deployment of the kits enables quickly stopping, or significantly  
reducing bleeding from a blood vessel (artery or vein), organ and/or other tissue where bleeding is present as a  
result of an impact trauma such as a knife wound or gun shot. Thus, the devices can be configured to be sized  
20 for a variety of applications.

[00274] While preferred embodiments of the present invention have been shown and described herein, it will  
be obvious to those skilled in the art that such embodiments are provided by way of example only. Numerous  
variations, changes, and substitutions will now occur to those skilled in the art without departing from the  
invention. It should be understood that various alternatives to the embodiments of the invention described  
25 herein may be employed in practicing the invention. It is intended that the following claims define the scope  
of the invention and that methods and structures within the scope of these claims and their equivalents be  
covered thereby.

## CLAIMS

## WHAT IS CLAIMED IS:

1. A closure device comprising:
  - (a) a distal flexible skirt with a self-intersecting geometry; and
  - 5 (b) a stem with one end contacting a proximal surface of the distal flexible skirt.
2. The closure device of claim 1, wherein the distal flexible skirt comprises one or more bendable features.
3. The closure device of claim 2, wherein the bendable features are thin sections that form natural locations for flexure with applied external force.
- 10 4. The closure device of claim 1, wherein the self-intersecting geometry is configured to come in contact between two areas of the skirt surface when a force is applied in a select direction, thereby causing an increase in the magnitude of force needed to deflect the geometry an additional increment,
5. The closure device of claim 1, further comprising one or more proximally positioned radial extending elements, wherein the stem is positioned between the distal flexible skirt and the one or more radial  
15 extending element.
6. The closure device of claims 1, wherein the proximal surface of the distal flexible skirt has one of more of at least one of anchoring protrusions, nibs or ribs.
7. The closure device of claims 1, wherein the distal flexible skirt has a shape selected from round, triangular, oval, ovoid, elliptical, square, saucer, or rounded edges.
- 20 8. The closure device of claims 1, wherein the stem is positioned on a proximal surface of the flexible skirt at least one of centrally and non-centrally.
9. The closure device of claims 1, wherein the stem has a cross-sectional profile selected from the group comprising square, triangular, arrowhead, trapezoidal, rectangular, J, Y, hook, and bulbous.
10. The closure device of claims 1, wherein the stem further comprises a proximally positioned  
25 aperture therethrough.
11. The closure device of claims 1, wherein the stem further comprises one or more exterior features adapted and configured to achieve anchoring the stem in vivo.

12. The closure device of claims 1, wherein the stem further comprises a one or more slots along at least a portion of its length parallel to a stem longitudinal axis beginning at its proximal end.

13. The closure device of claims 1, wherein the stem has a proximal end adapted and configured to form a clasp, a socket, a breakable stem, or a tearable stem.

5 14. The closure device of claims 1, wherein at least one of the distal flexible skirt and stem are in releasable communication with a tether.

15. The closure device of claim 14 wherein the tether is one or more of a wire, a spring, a thread, a ribbon, a suture, and a tube.

16. A tissue closure delivery system comprising:

10 a tubular medical device;

a tissue closure delivery cartridge;

the closure device of claim 1;

a guide and seal assembly; and

a plunger,

15 wherein the tubular medical device is adapted and configured to releasably engage the tissue closure delivery cartridge at a proximal end, the tissue closure delivery cartridge is adapted and configured to releasably engage the guide and seal assembly at a proximal end, and the plunger is adapted and configured to be advanced through a lumen in each of the guide and seal assembly, the tissue closure delivery cartridge and the tubular medical device.

20 17. The tissue closure delivery system of claim 16 wherein the tubular medical device is one or more of: a needle, tube, guide wire, electrode wire, intravenous wire, introducer, sheath, dilator, catheter, laparoscope, endoscope, trocar, deployment tool, or cannula.

18. The tissue closure delivery system of claim 16 further comprising a delivery capsule having a cartridge body; a tapered distal tip; a compressible section; a clear section; a lumen extending therethrough,  
25 wherein the clear section is adapted and configured to house the closure device.

19. The tissue closure delivery system of claim 18 wherein at least one of the tubular medical device or the delivery capsule further comprises a valve.

20. The tissue closure delivery system of claim 18 wherein the delivery capsule further comprises one or more of the following: one or more proximally positioned detent features on an exterior surface of the cartridge body; one or more distally positioned undercuts; an exterior groove in the cartridge body; a one-way snap feature; an undercut central bore; or one or more collets.

5 21. The tissue closure delivery system of claim 18 wherein the capsule is adapted and configured to receive a plunger through a central aperture.

22. The tissue closure delivery system of claim 21 wherein the capsule is adapted and configured to permit the plunger to move in a first axial direction and resist movement in a second axial direction different than the first direction.

10 23. A method for tissue closure, comprising:

inserting a distal end of a tubular medical device into a vessel through an opening in vessel tissue;

accepting the closure device of claim 1 at or near the proximal end of the tubular medical device; and

15 advancing the closure device through the tubular medical device, thereby allowing the closure device to partially exit or completely exit the distal end of the tubular medical device within the vessel.

24. The method of claim 23, further comprising removing the tubular medical device from the vessel through the opening in the vessel tissue.

20 25. The method of claim 24, further comprising permitting the stem of the closure device to enter the opening in the vessel tissue while the distal flexible skirt remains within the vessel.

26. The method of claim 23, wherein the closure device is connected to a tether.

27. The method of claim 26, further comprising removing the tether from the closure device.

28. The method of claim 26, further comprising allowing the tether to remain connected to the closure device.

25 29. The method of claim 28, wherein the tether is formed of a bioabsorbable material.

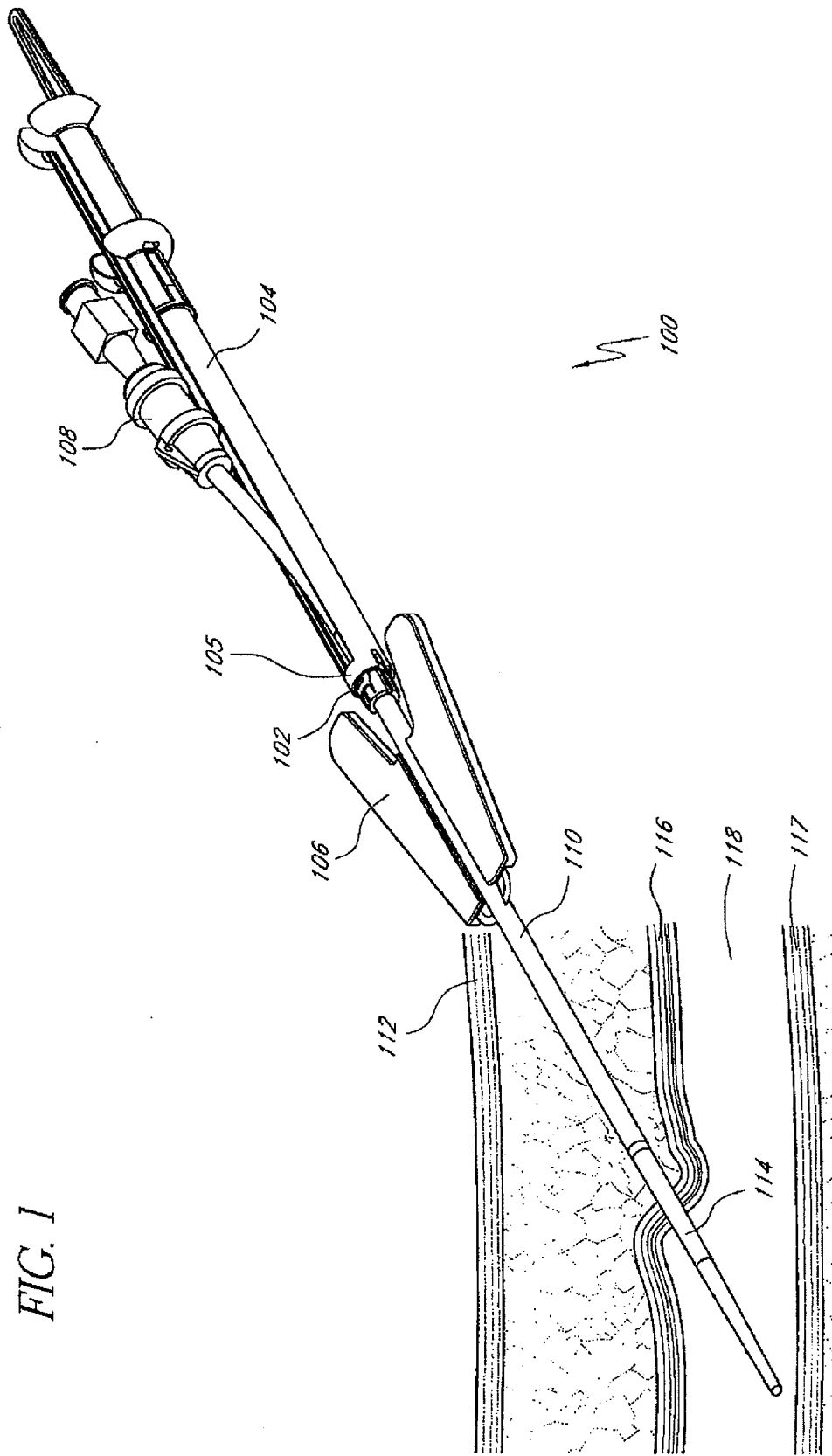

FIG. 1

FIG. 2

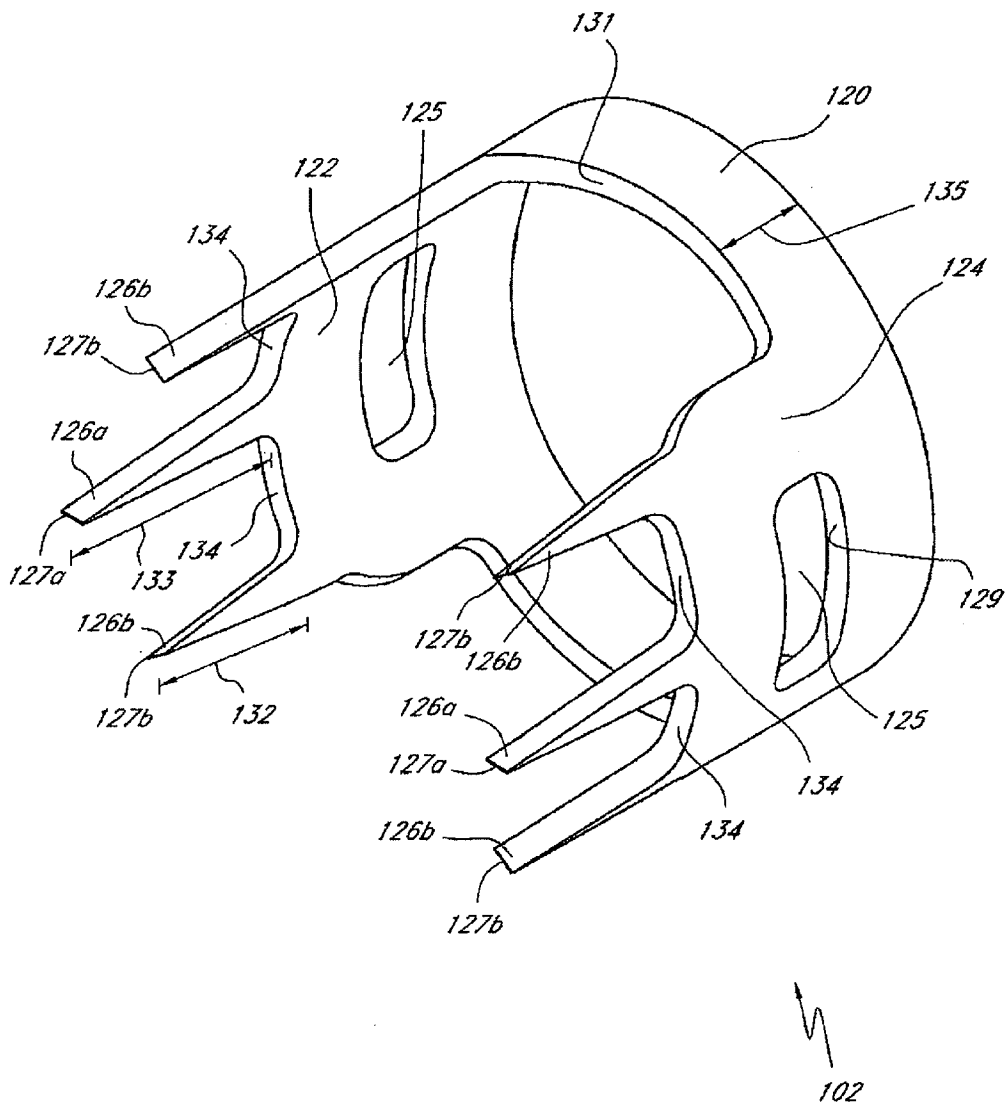

FIG. 3

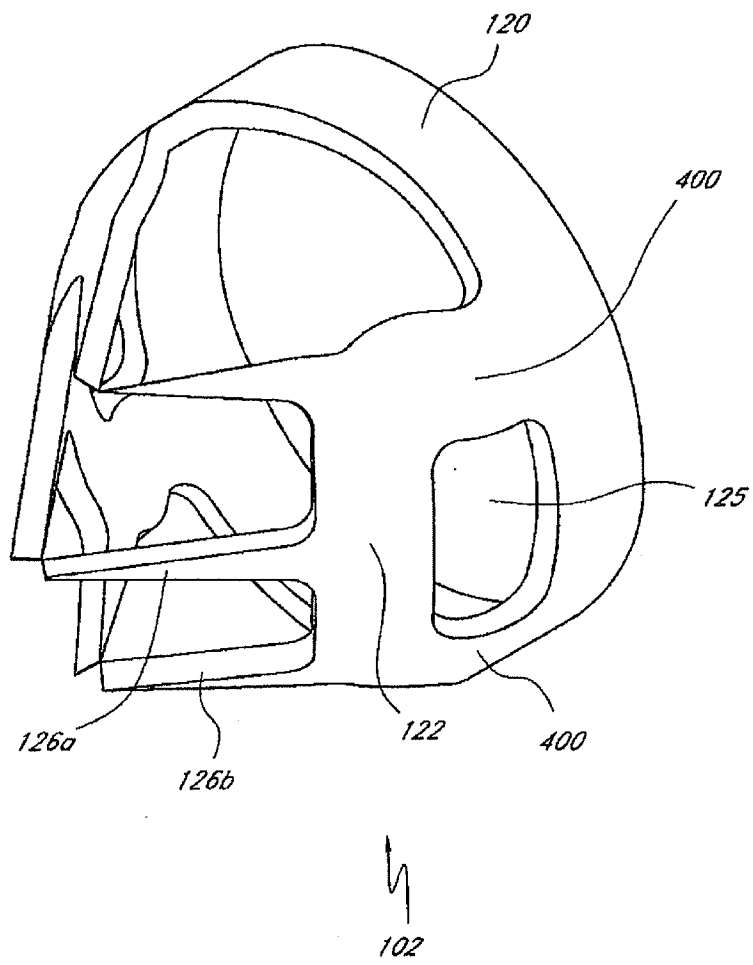

FIG. 4

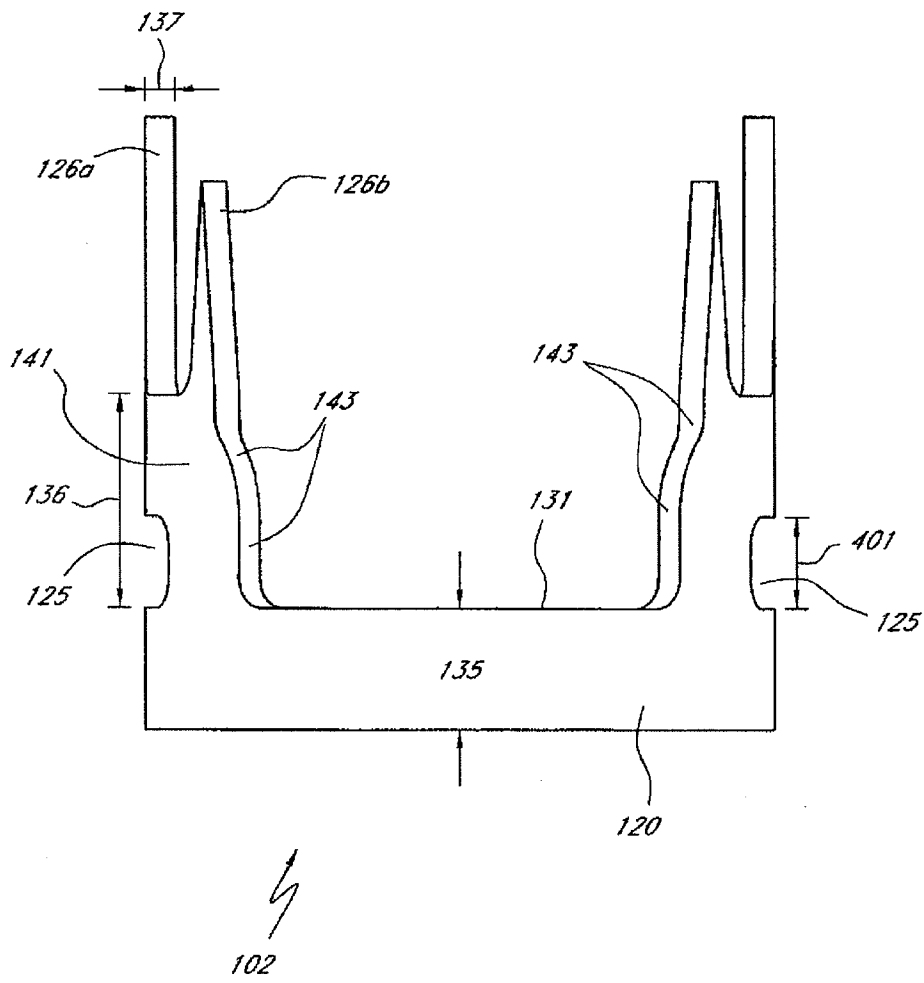

FIG. 5

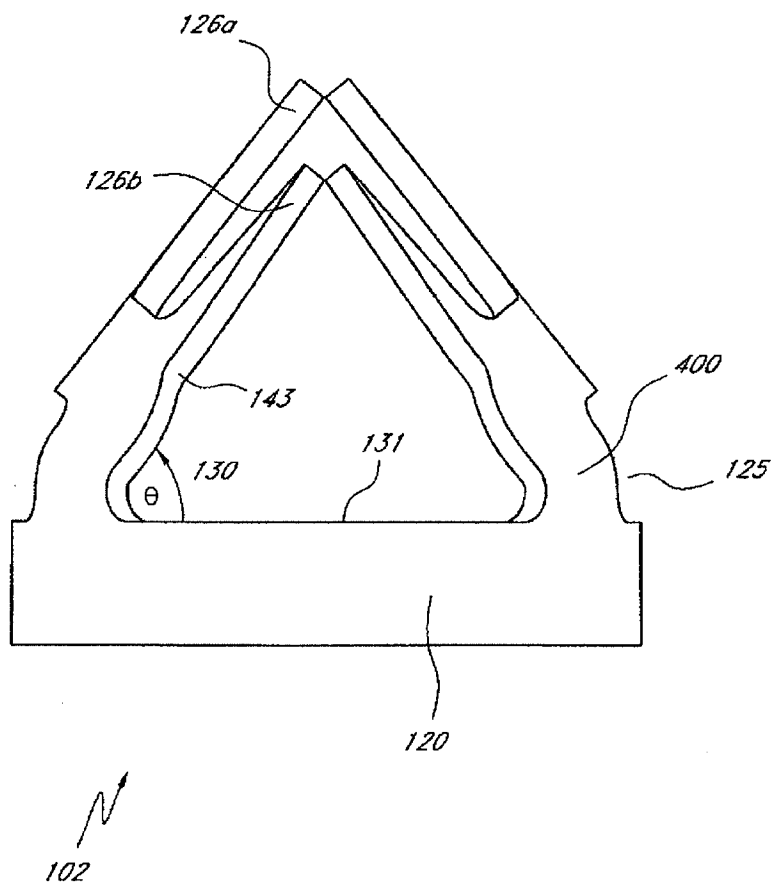
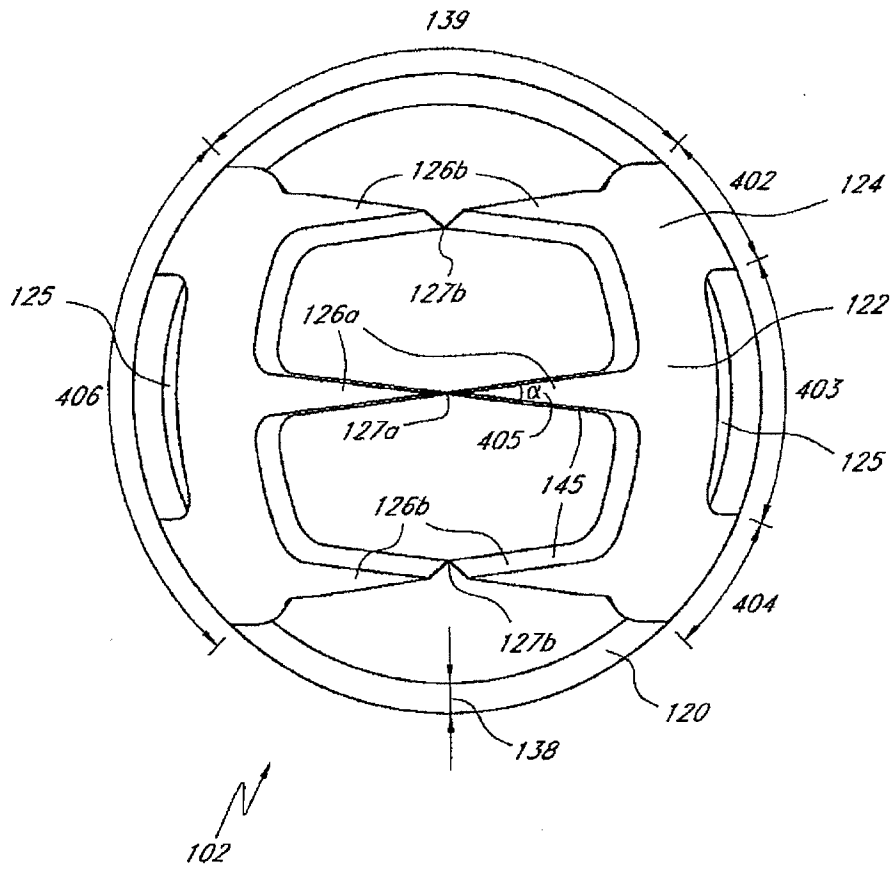

FIG. 6



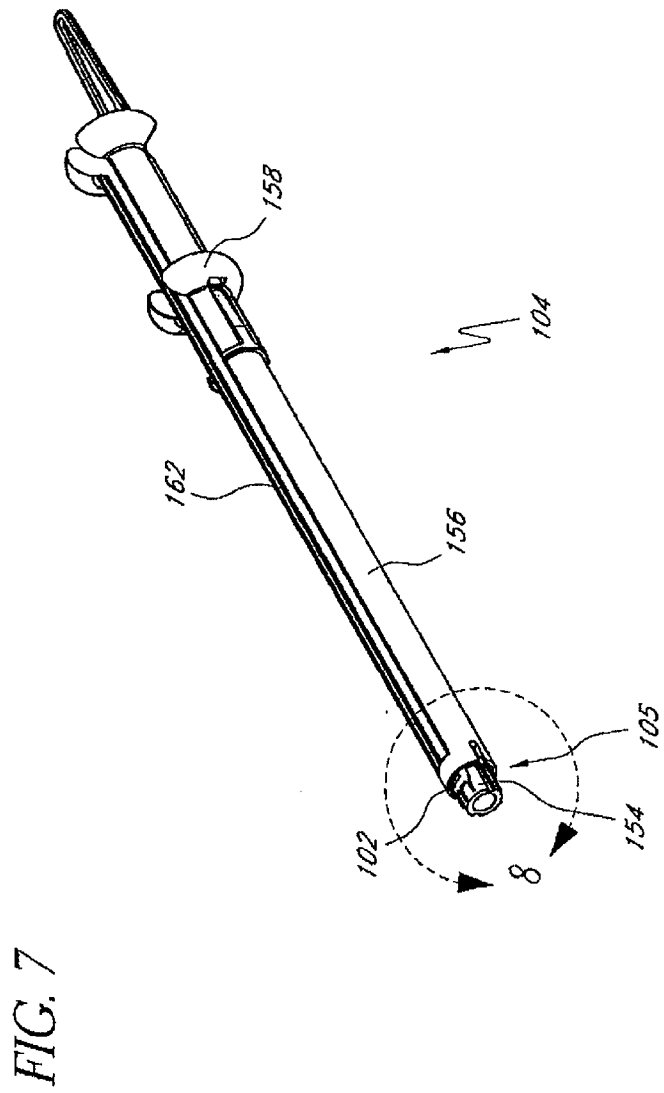

FIG. 8

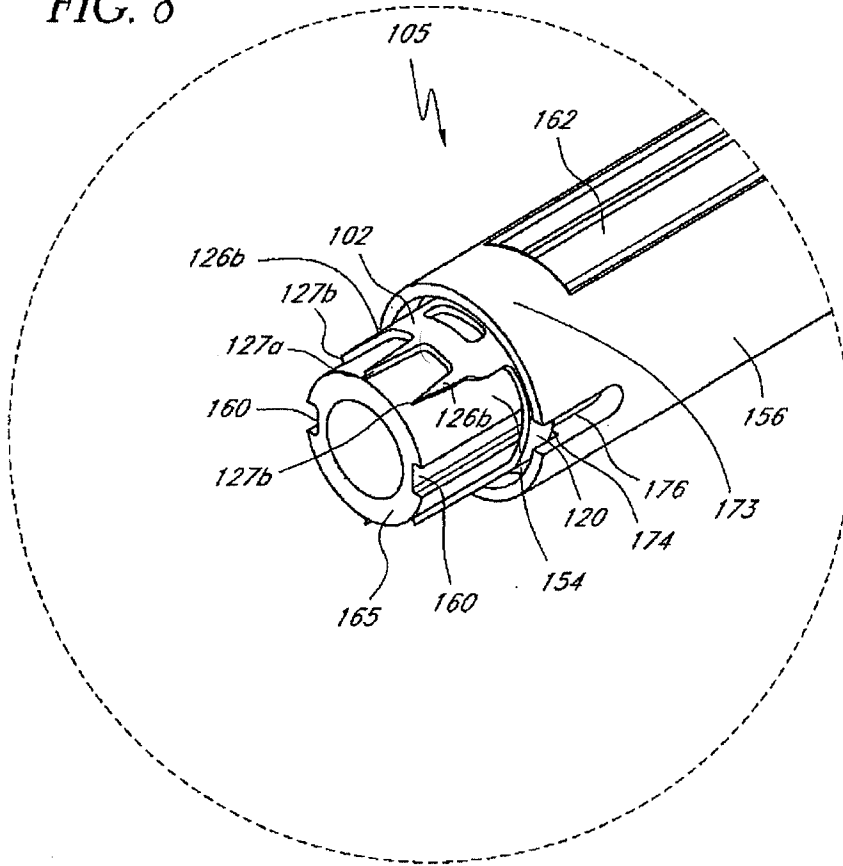

FIG. 9

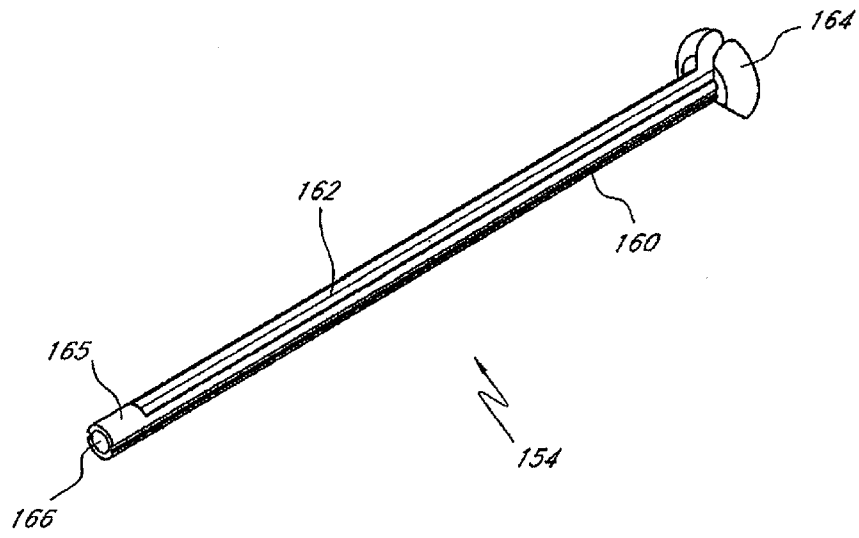

FIG. 10

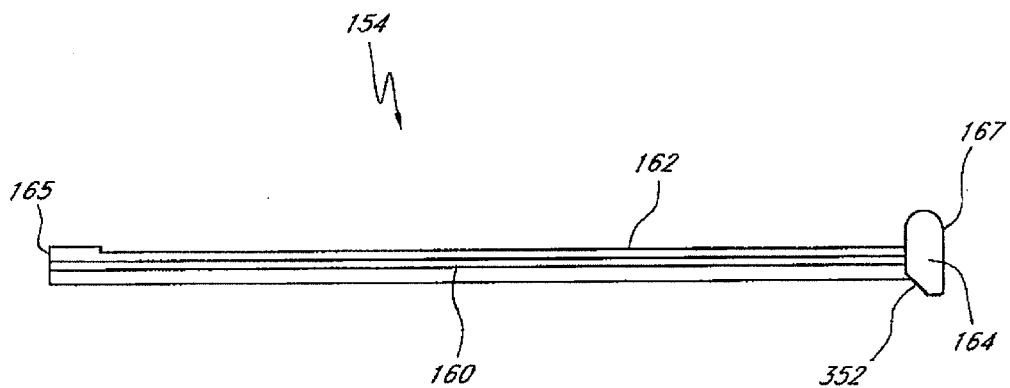

FIG. 11

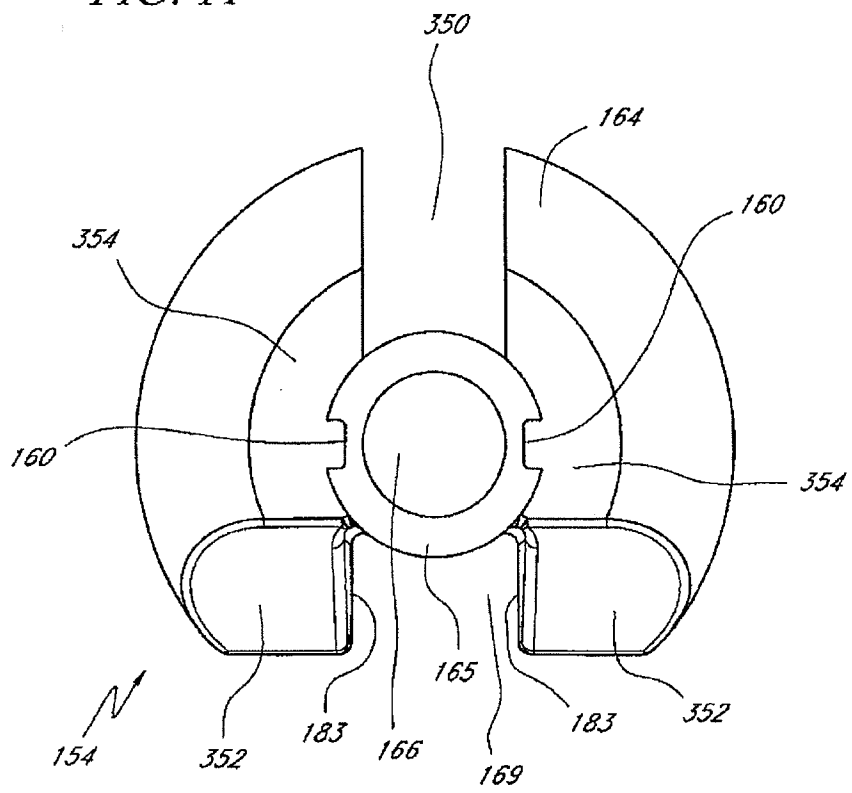

FIG. 12

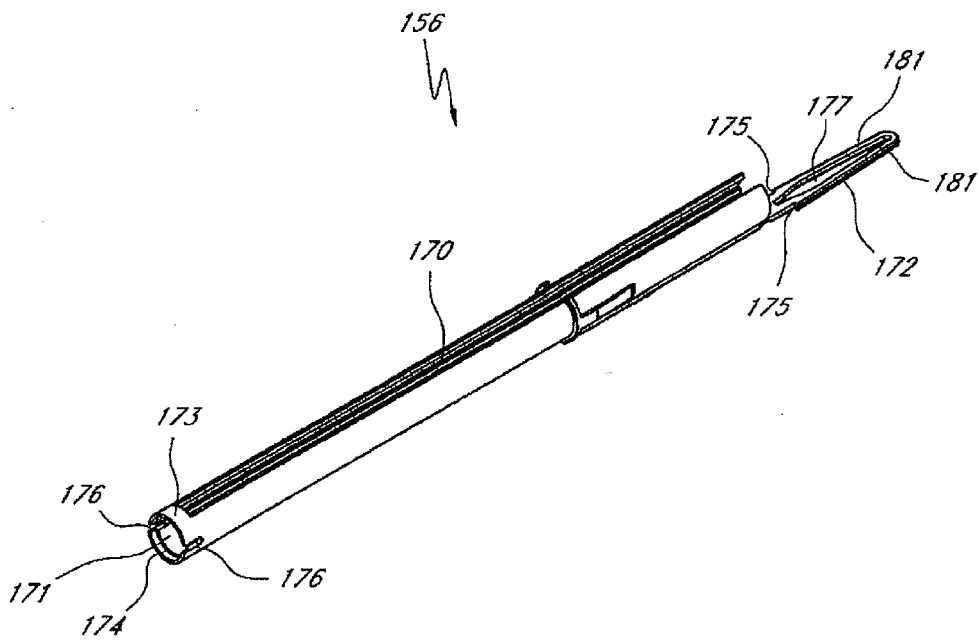

FIG. 13

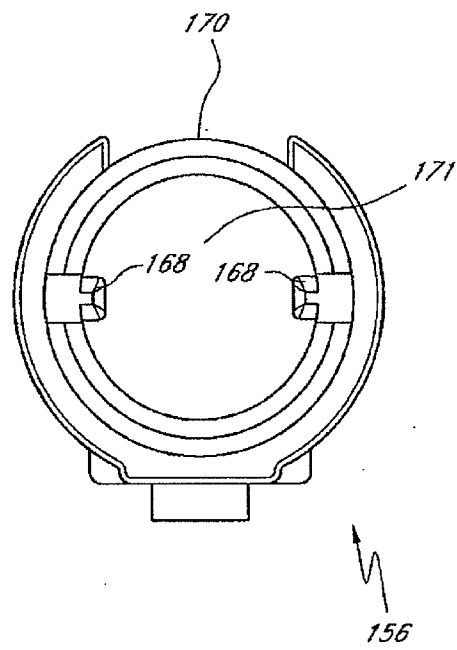

FIG. 14

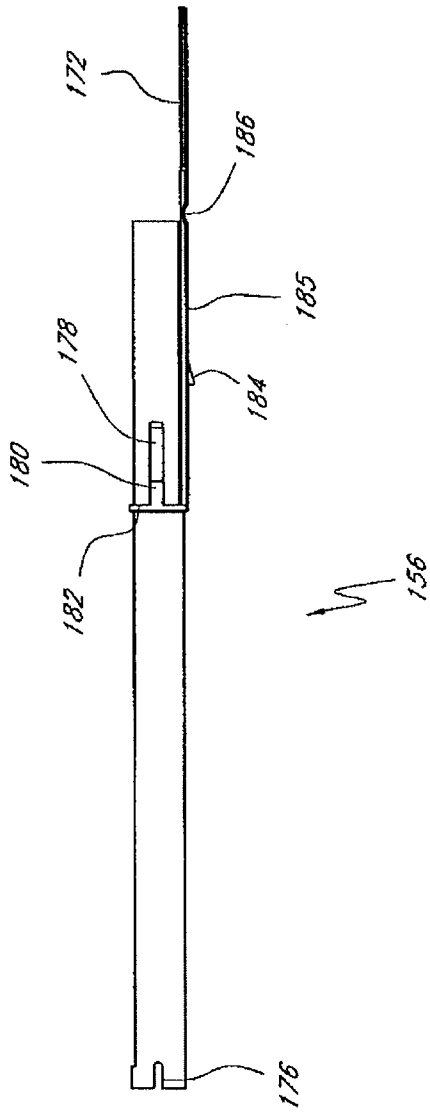

FIG. 15

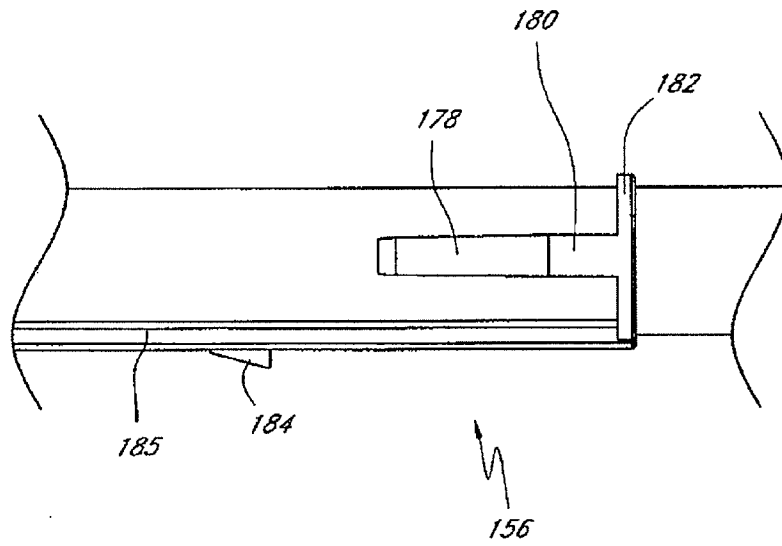

FIG. 16

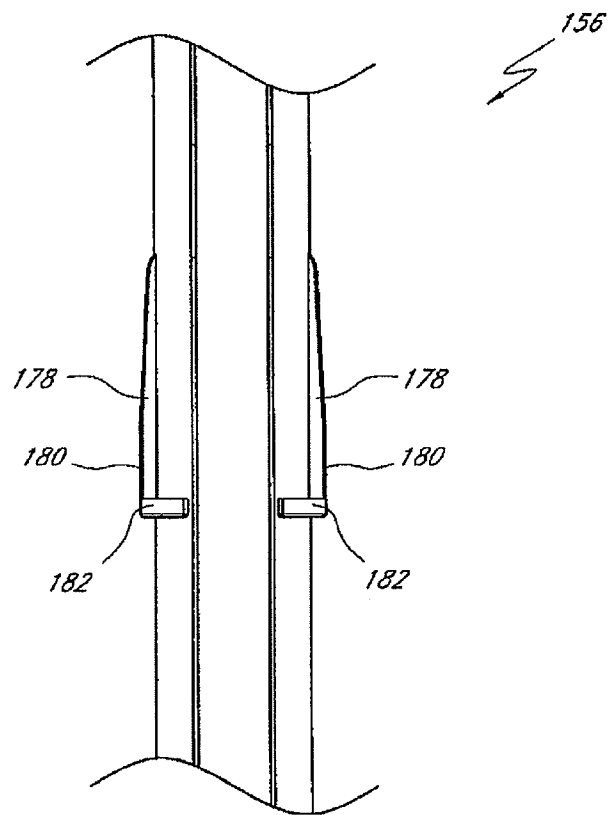
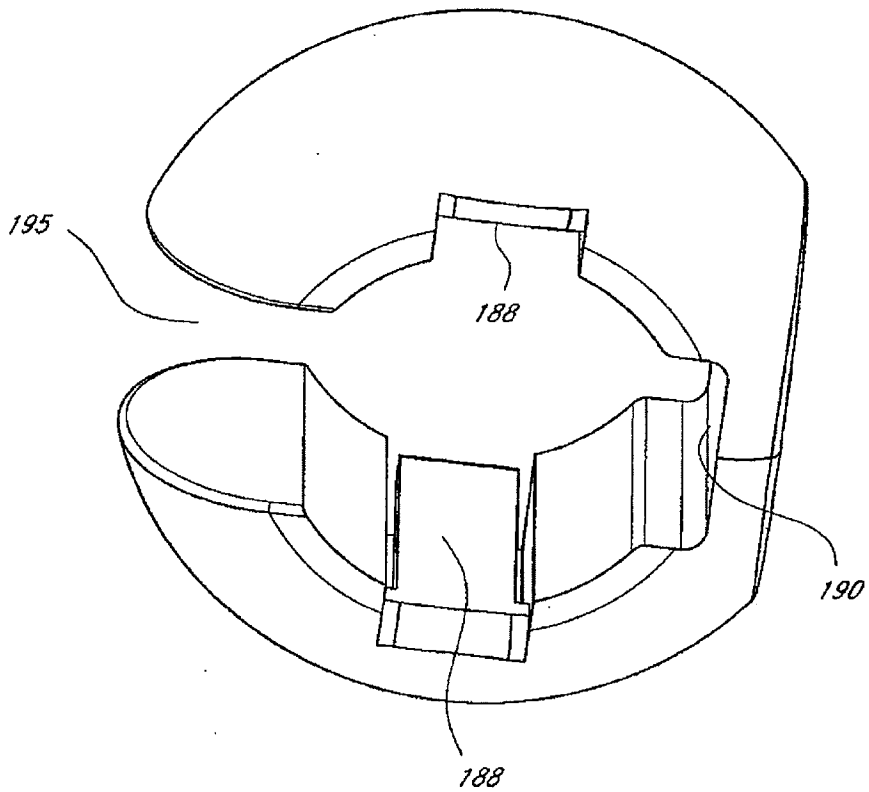
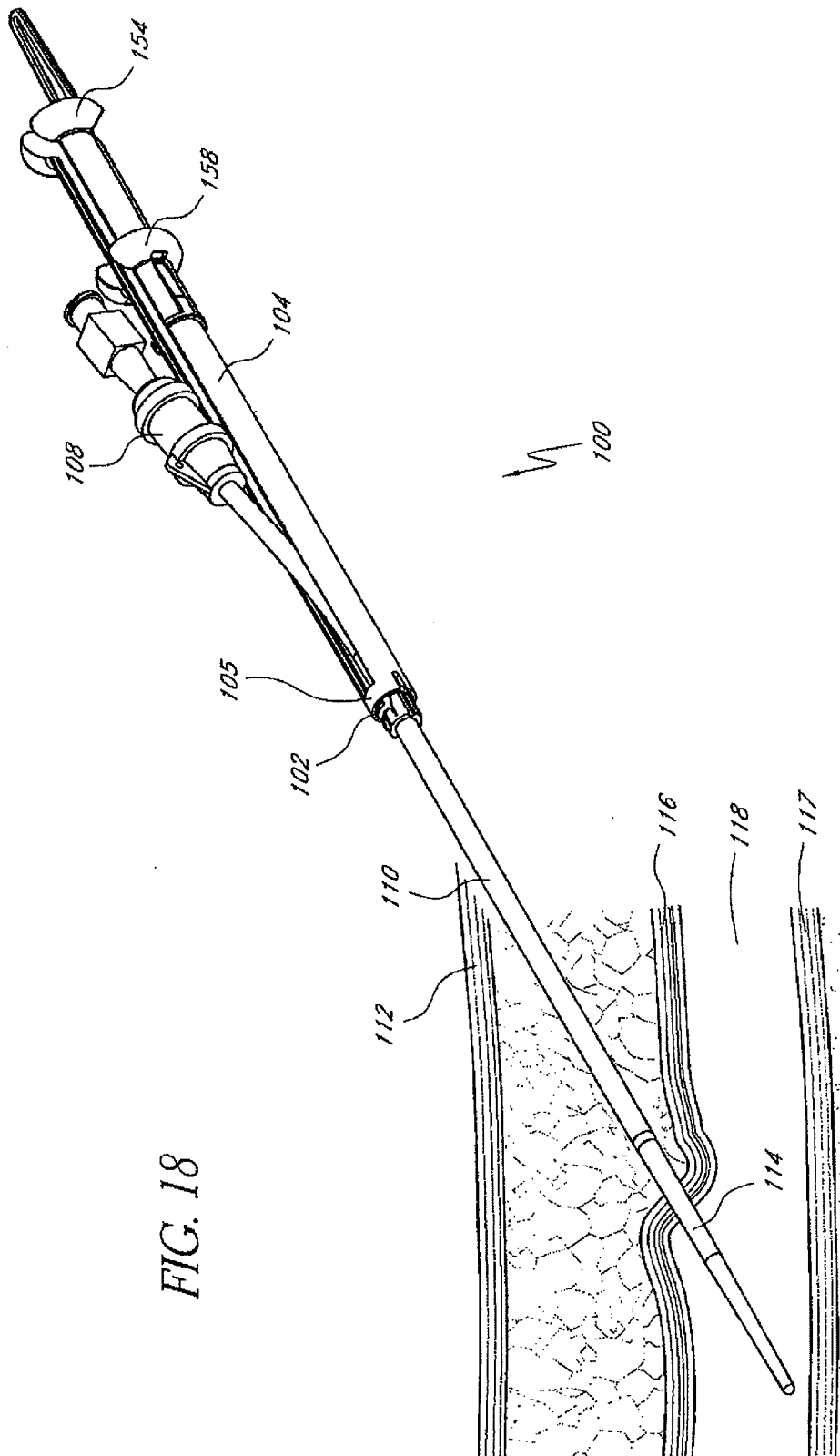
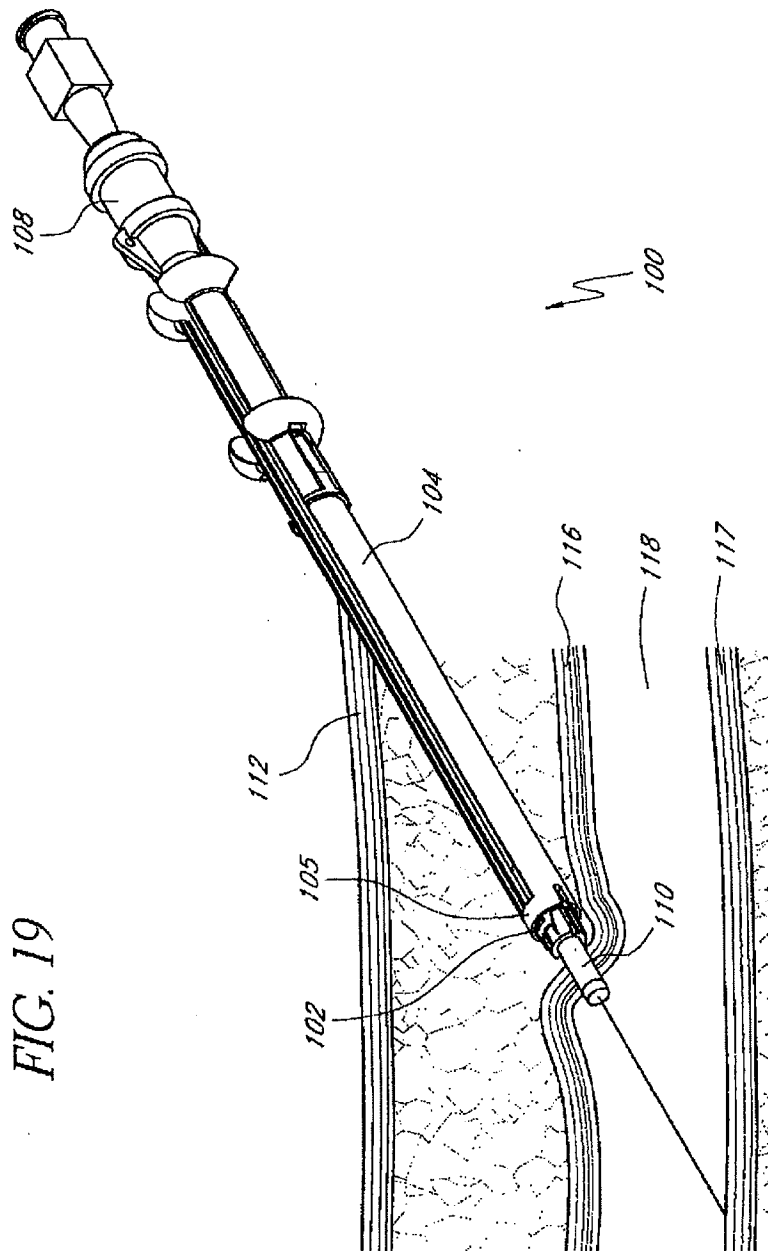

FIG. 17

158







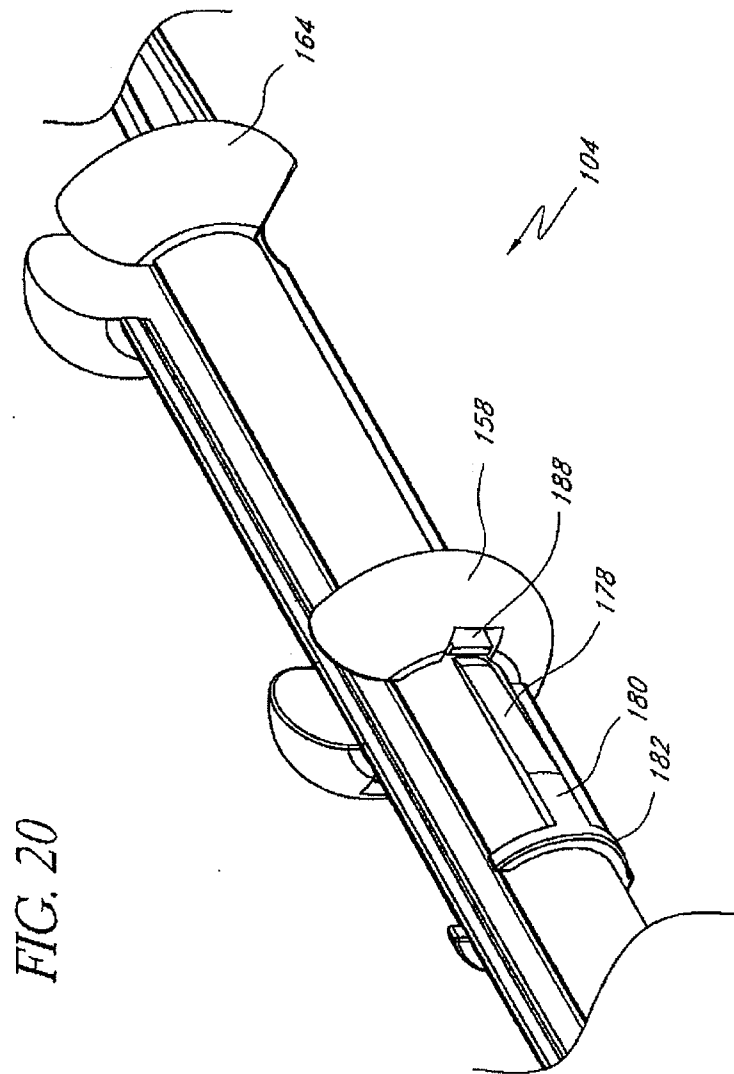
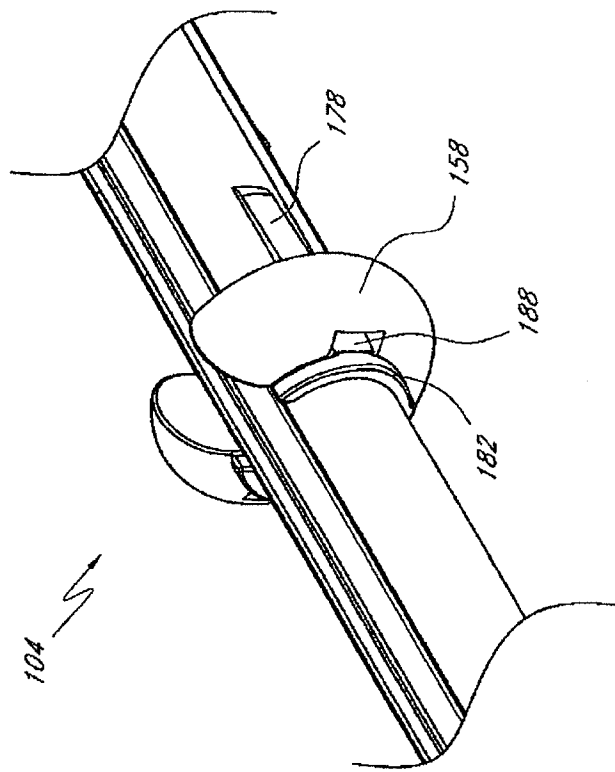



FIG. 22



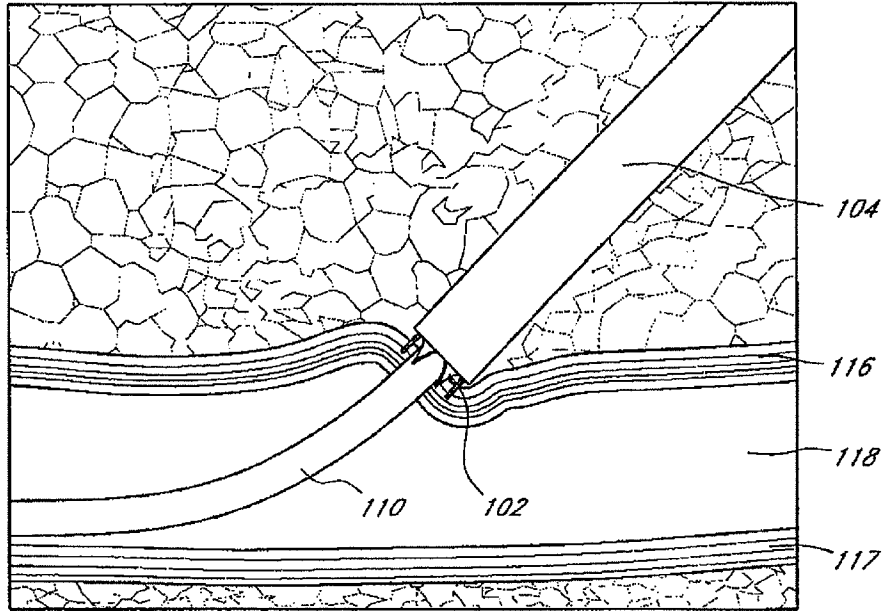

FIG. 23

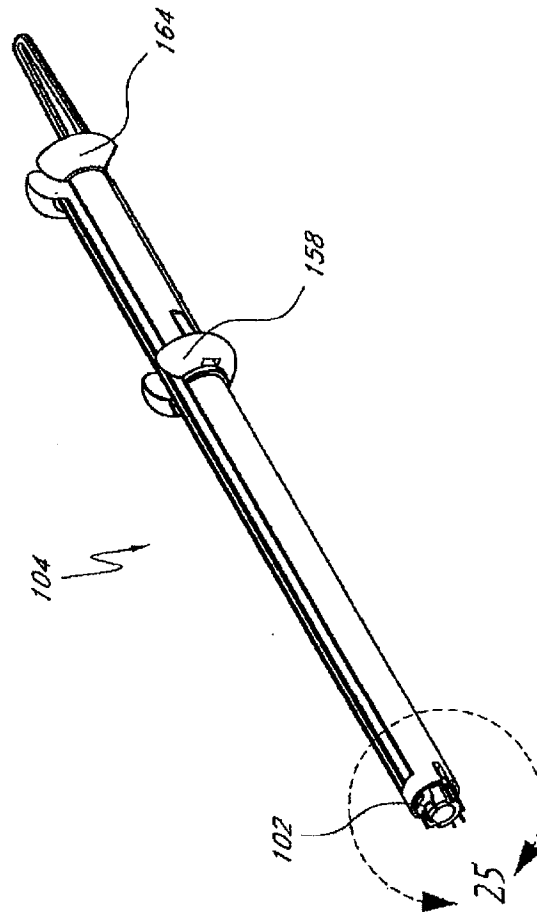

FIG. 24

FIG. 25

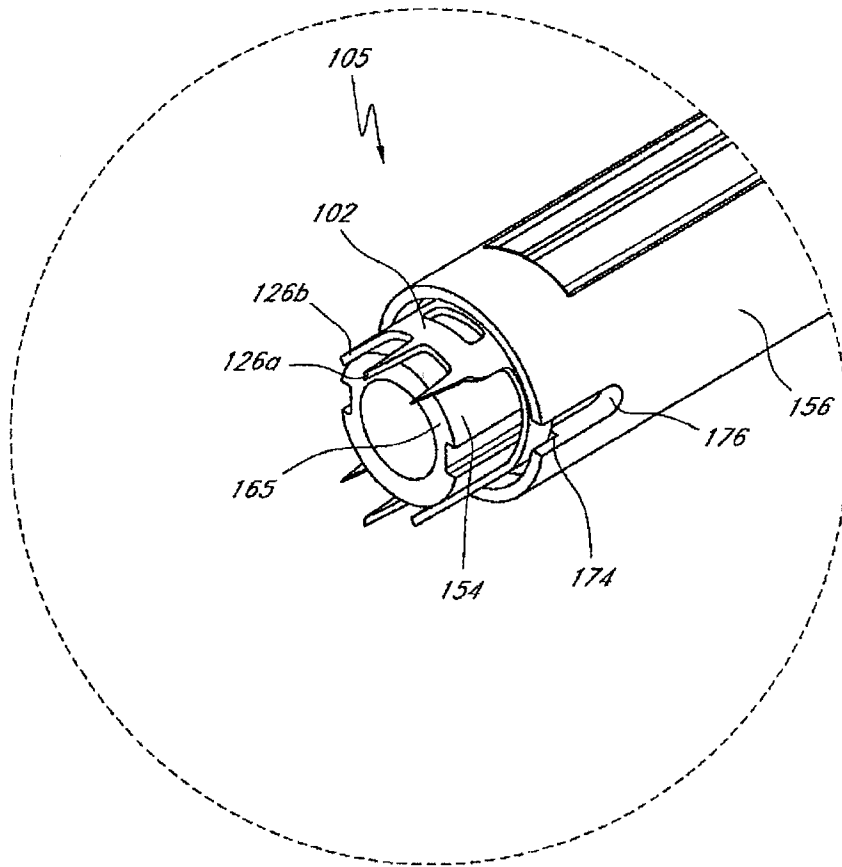

FIG. 26

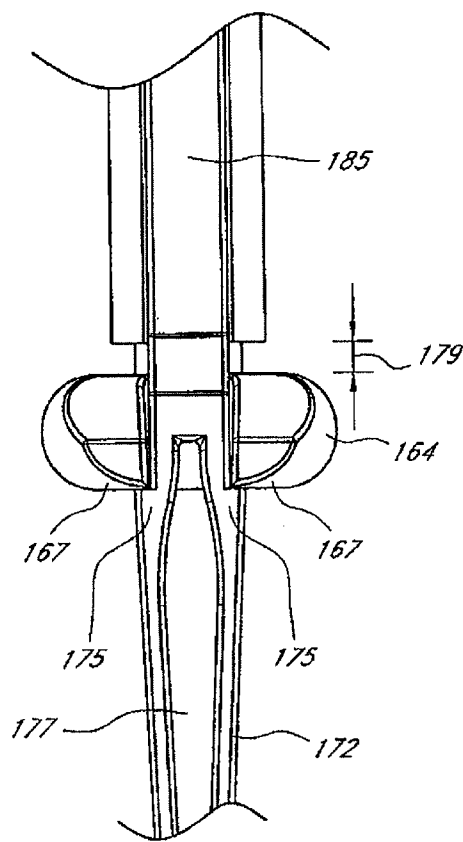

FIG. 27

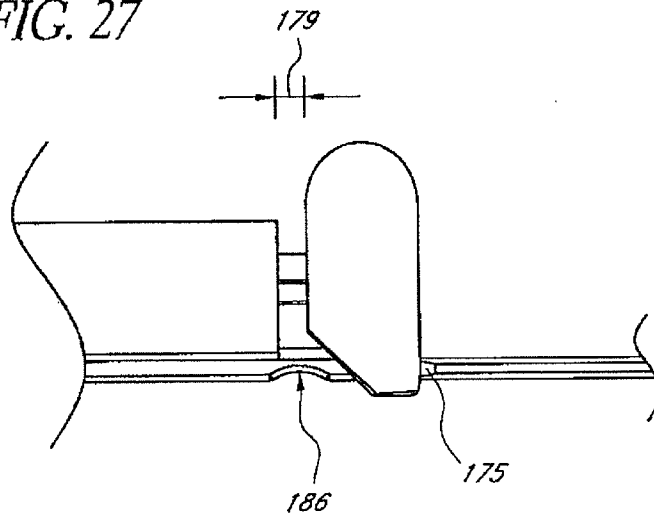
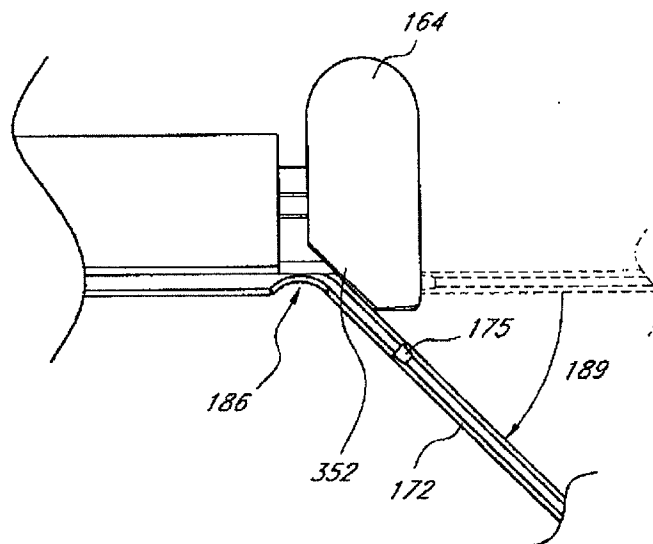

FIG. 29



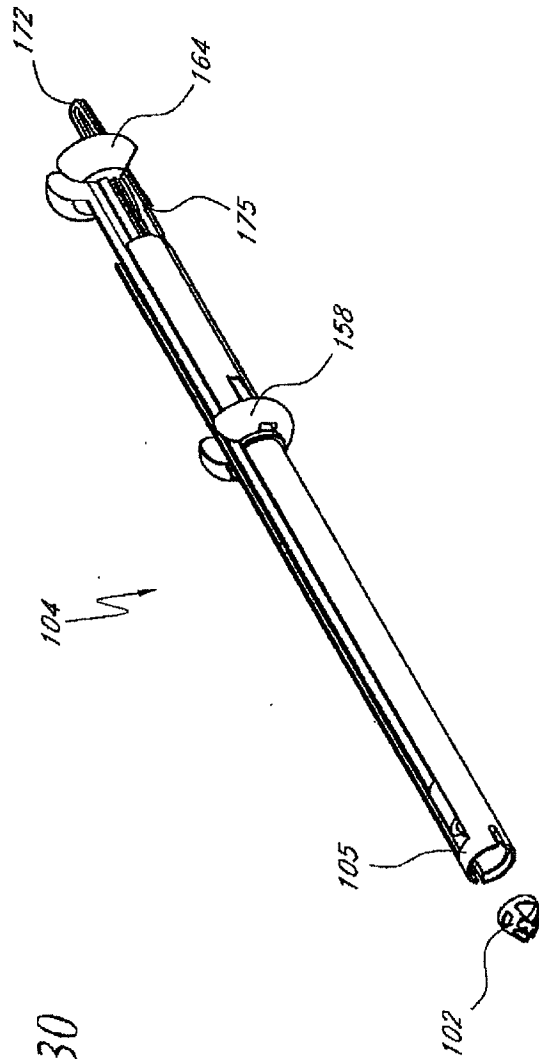

FIG. 30

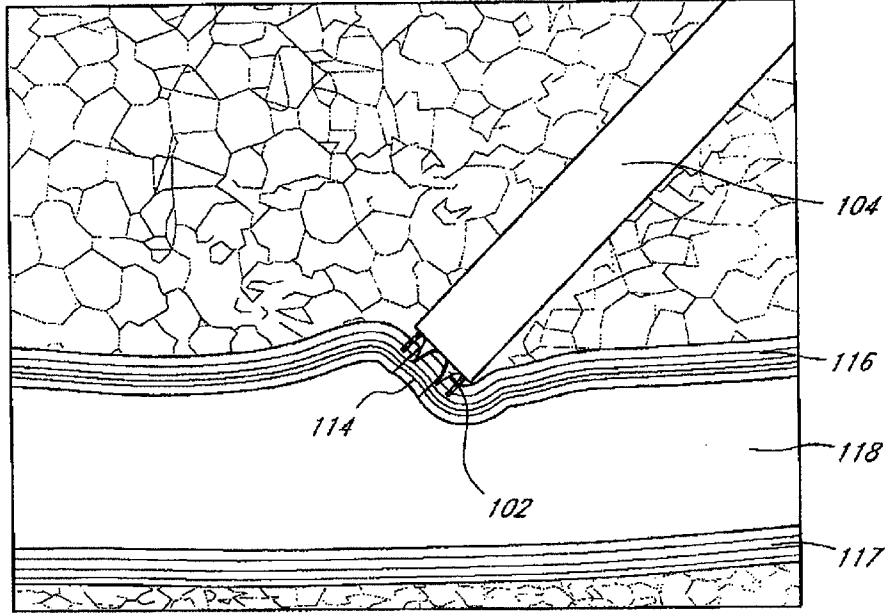

FIG. 28

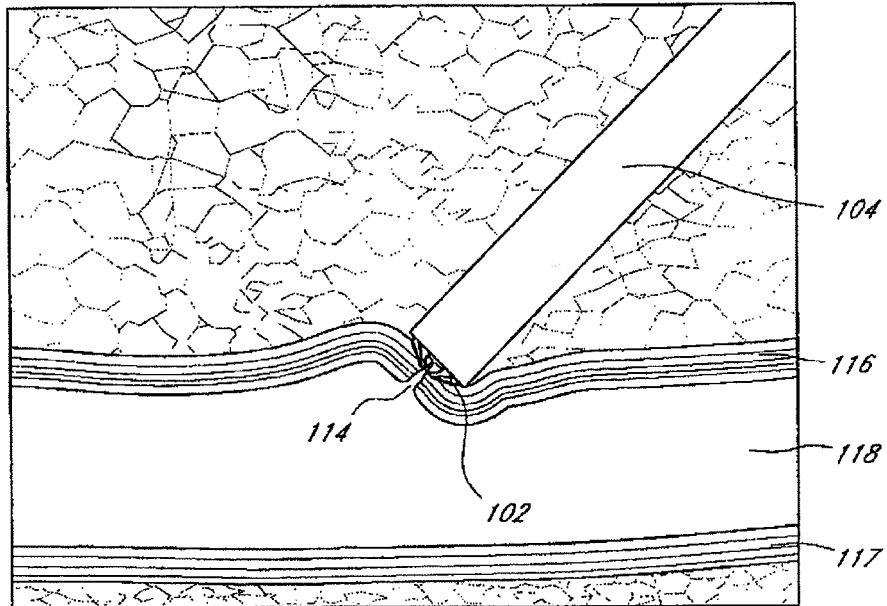

FIG. 31

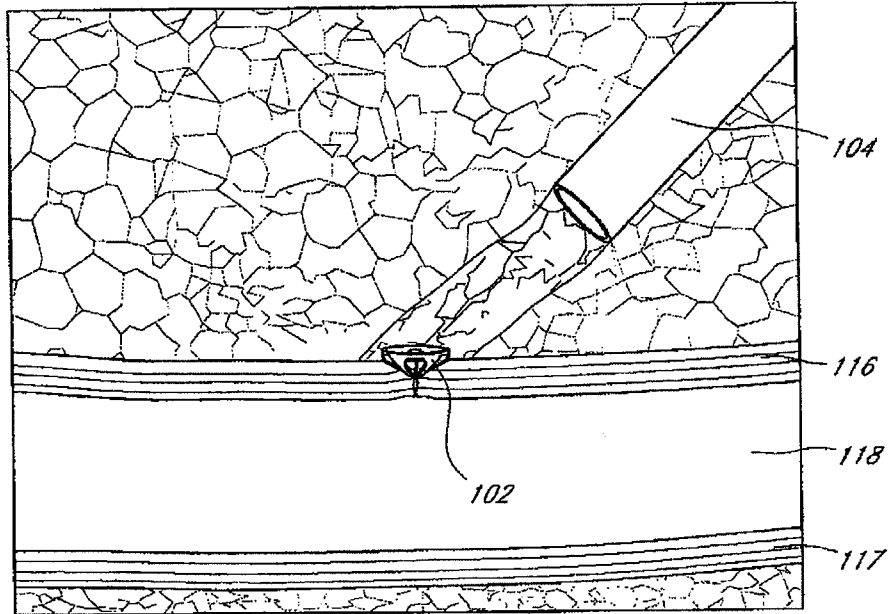

FIG. 32

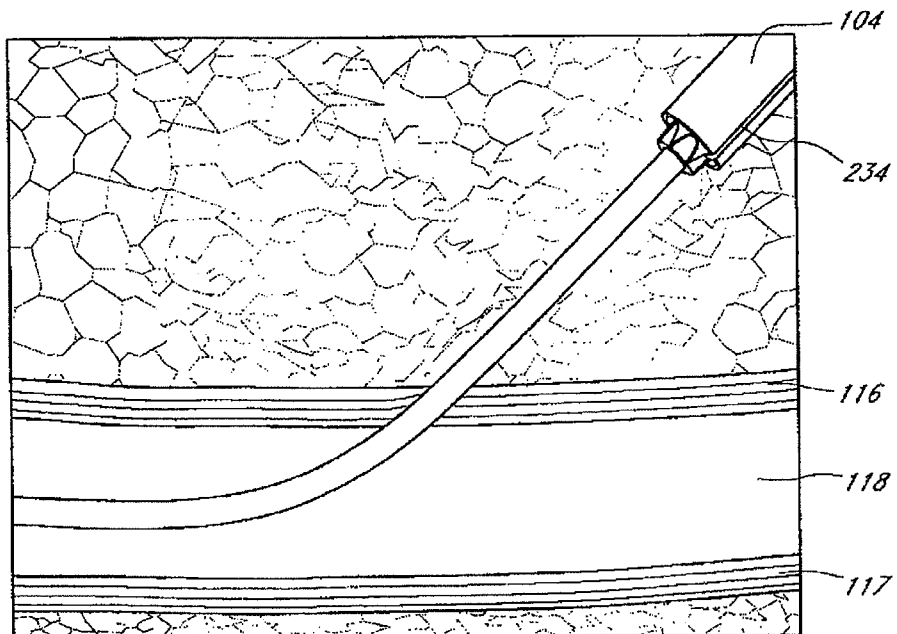

FIG. 33

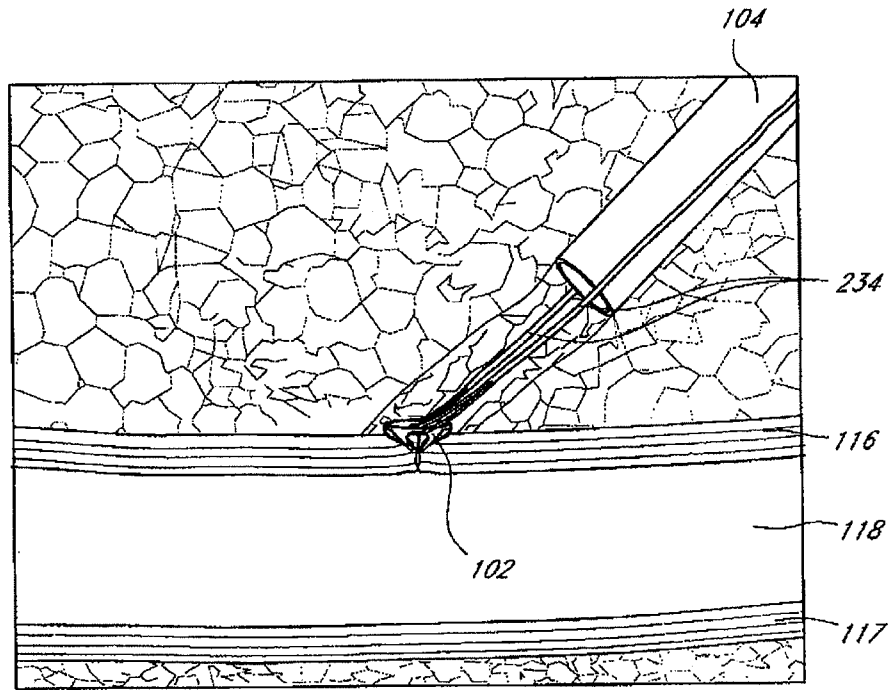

FIG. 34

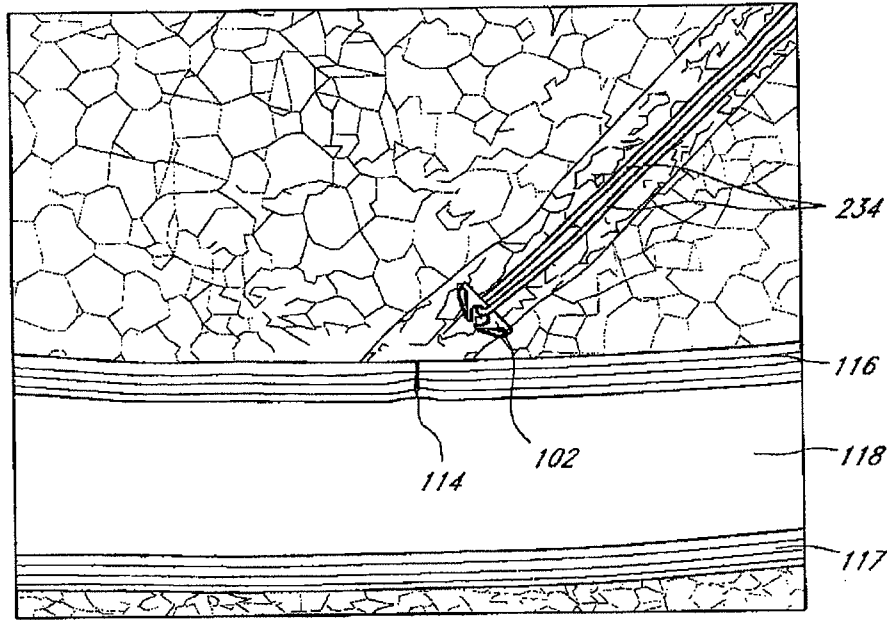
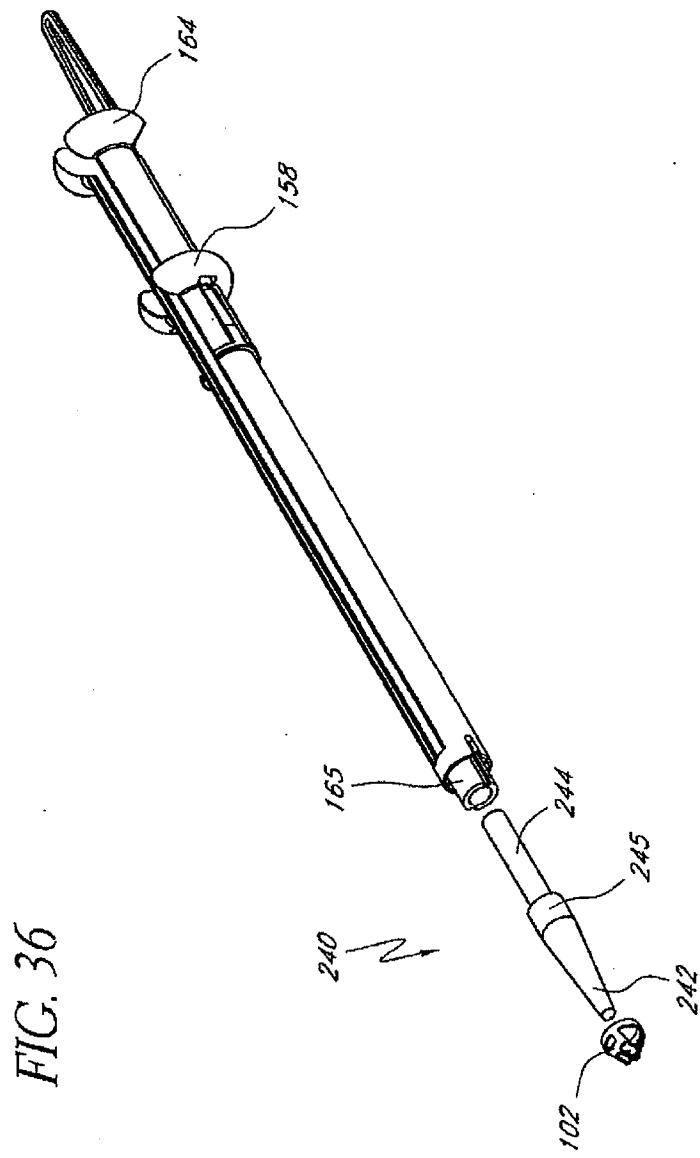
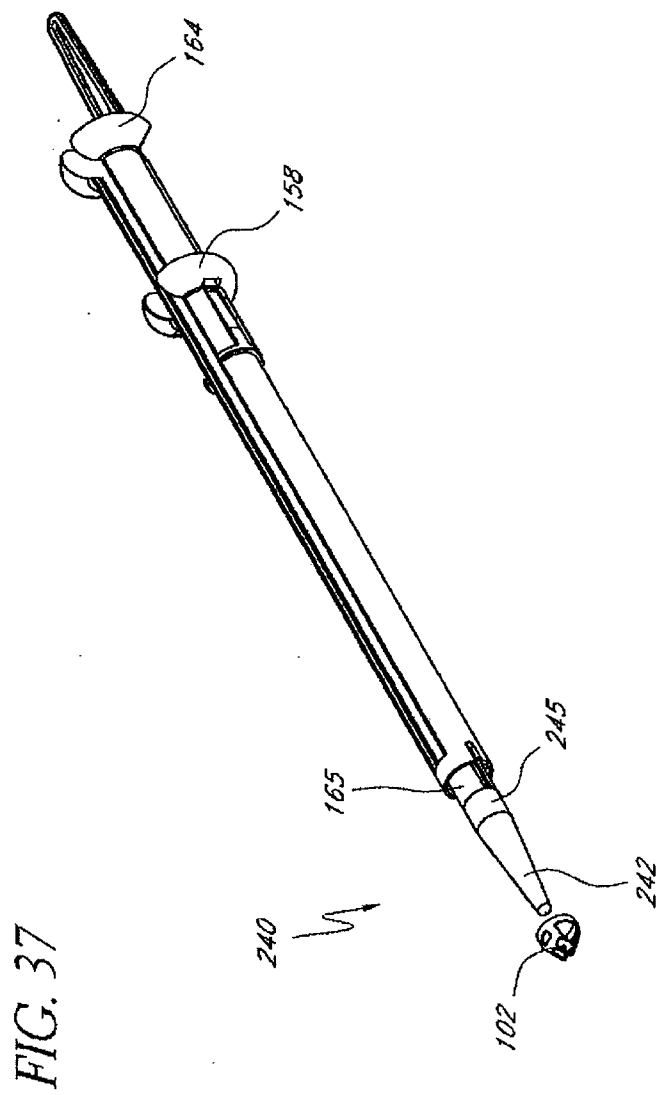
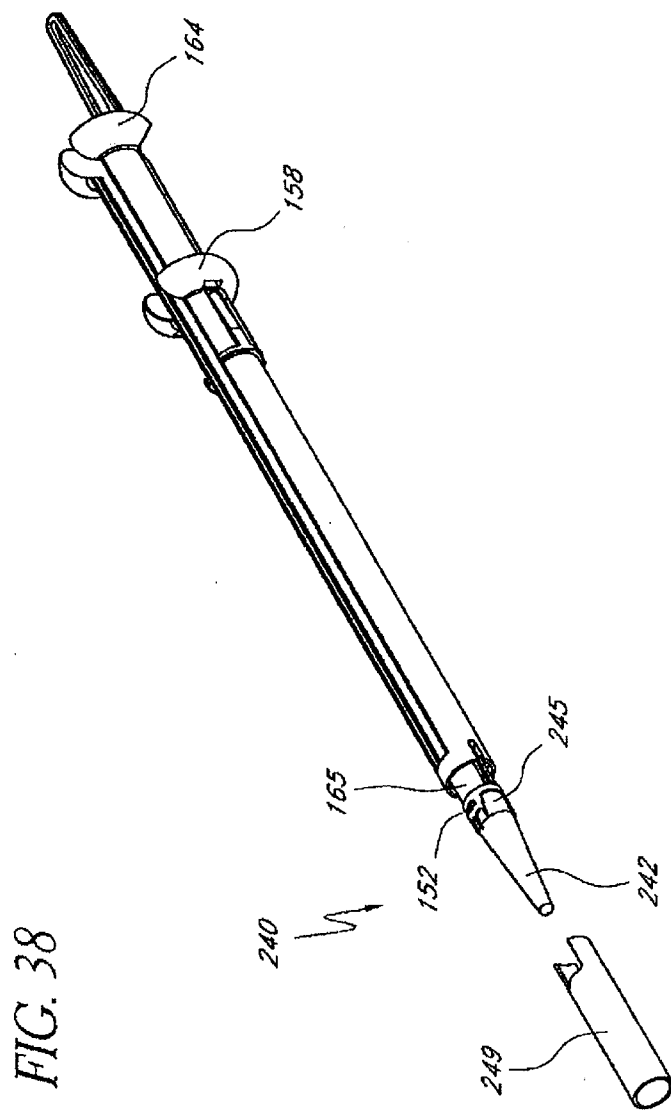

FIG. 35







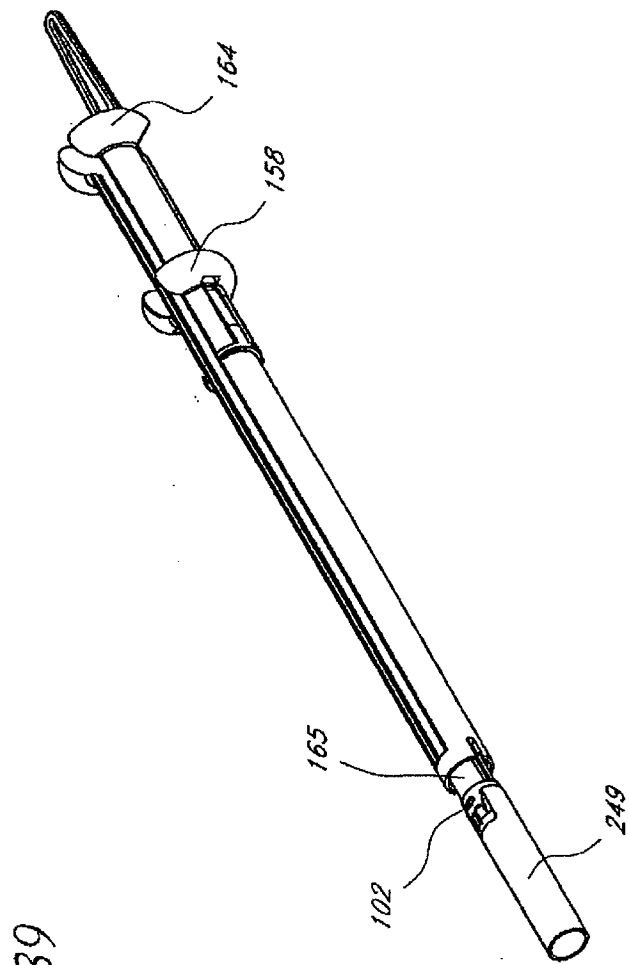

FIG. 39

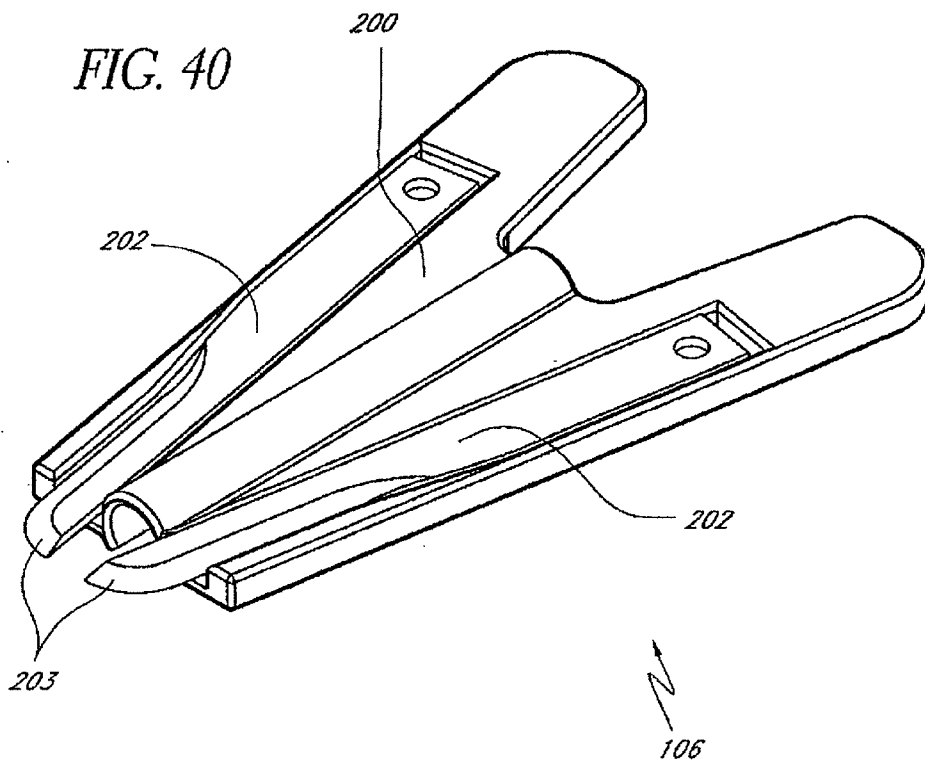

FIG. 41

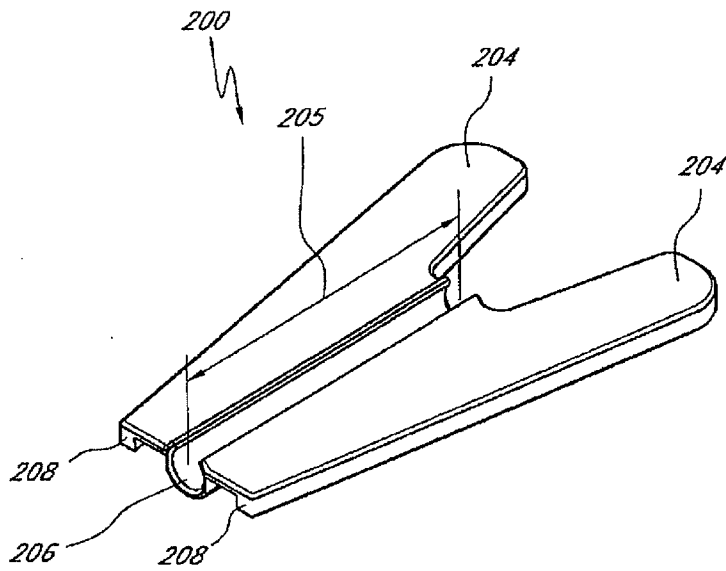
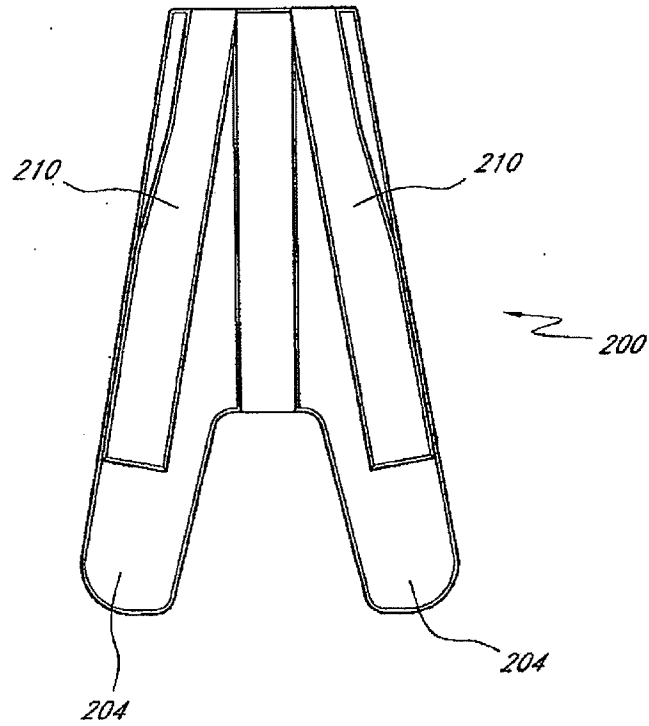
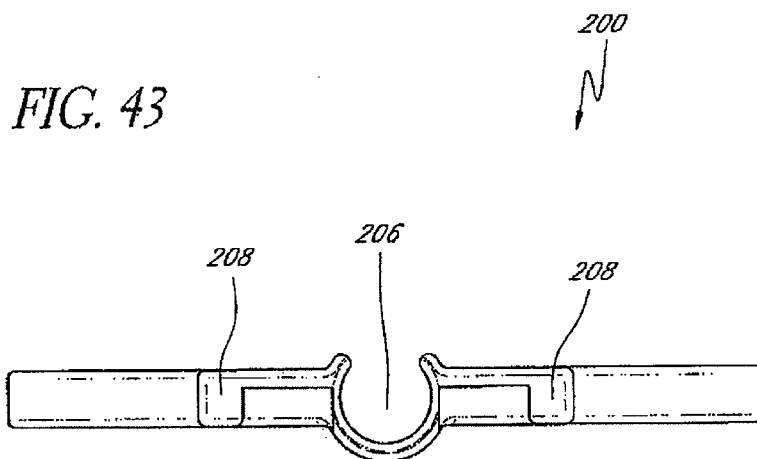

FIG. 42





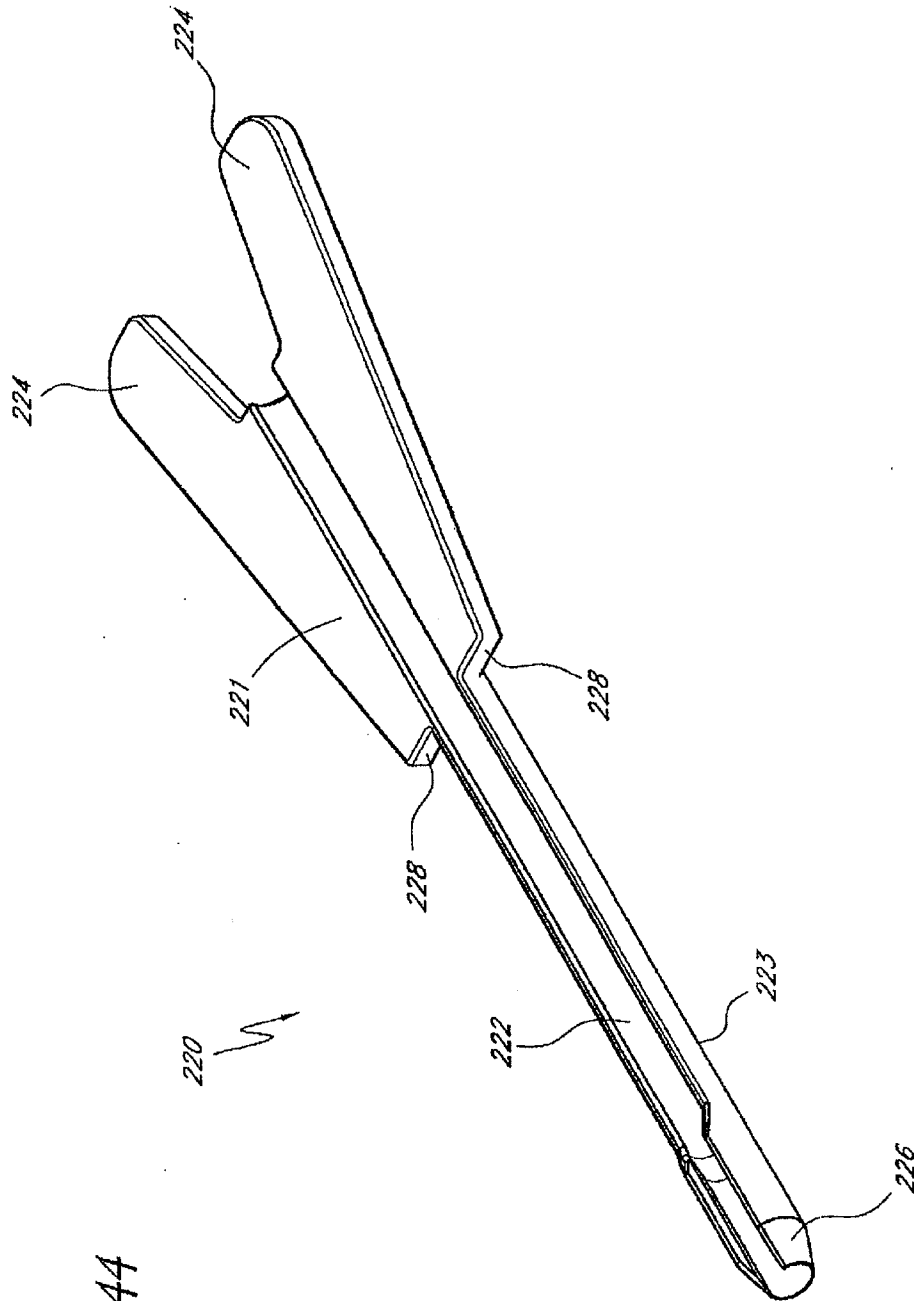

FIG. 44

FIG. 45

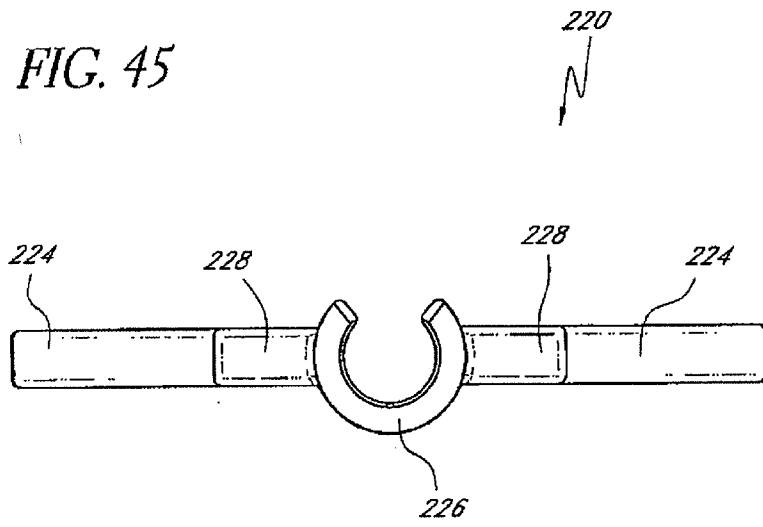

FIG. 46

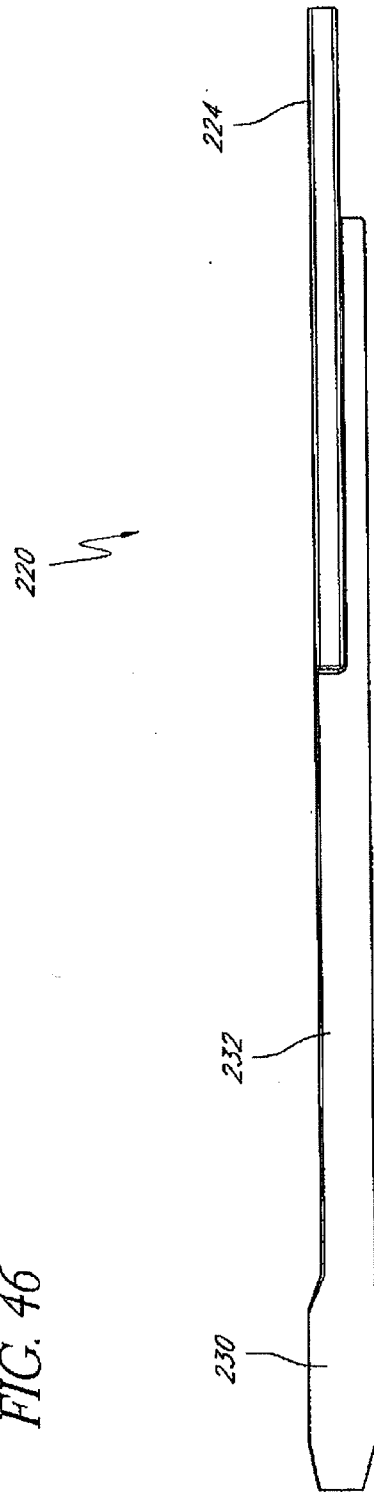

FIG. 47A

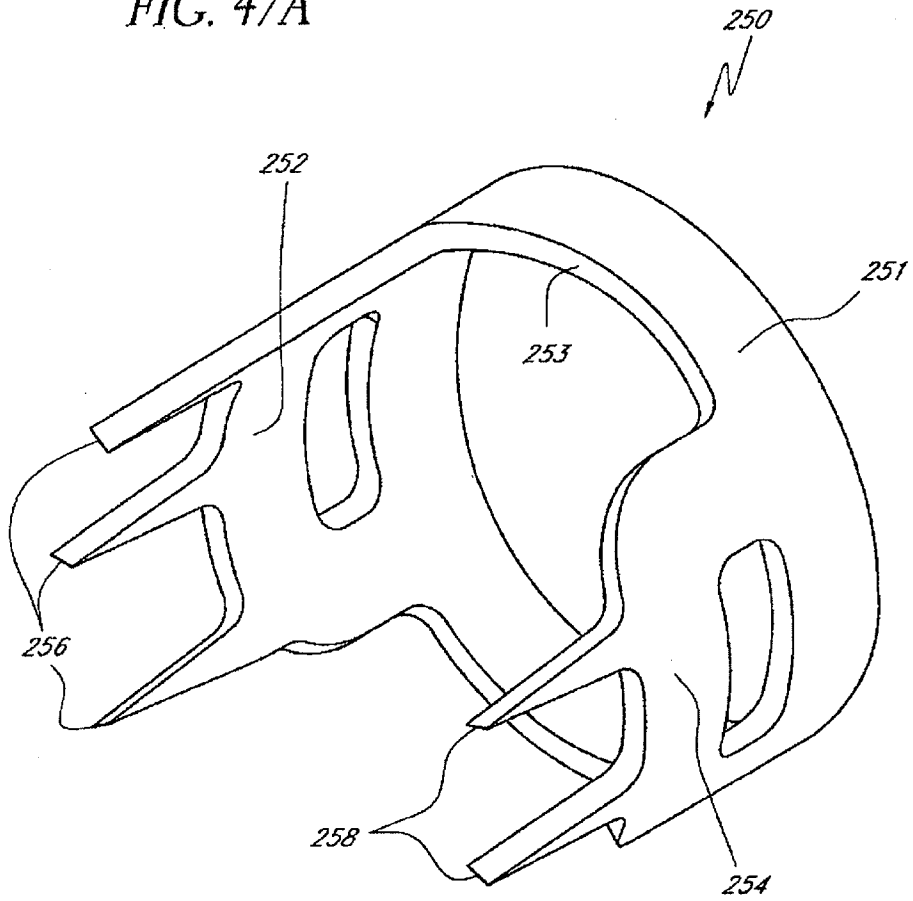

FIG. 47B

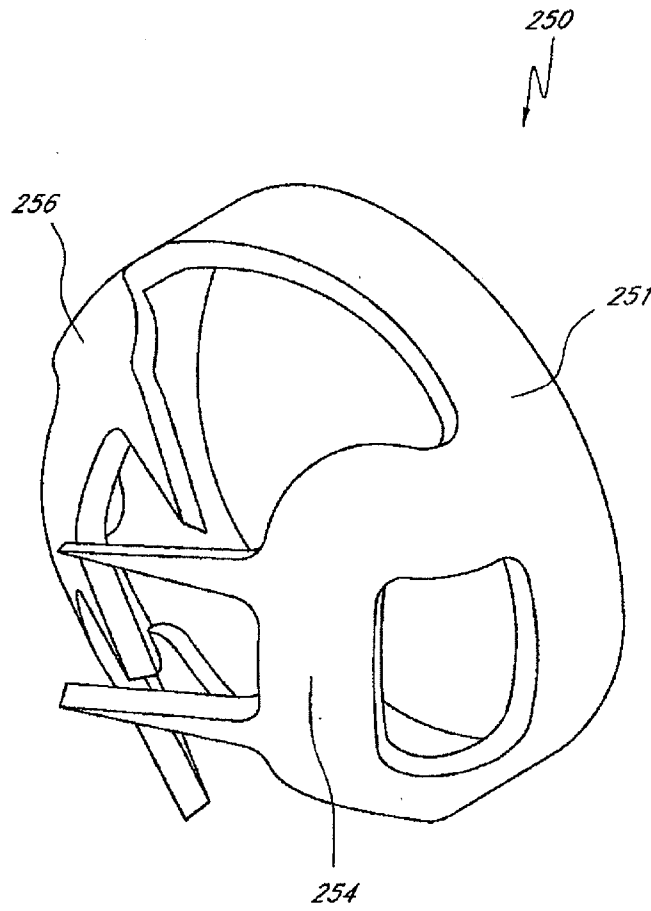

FIG. 47C

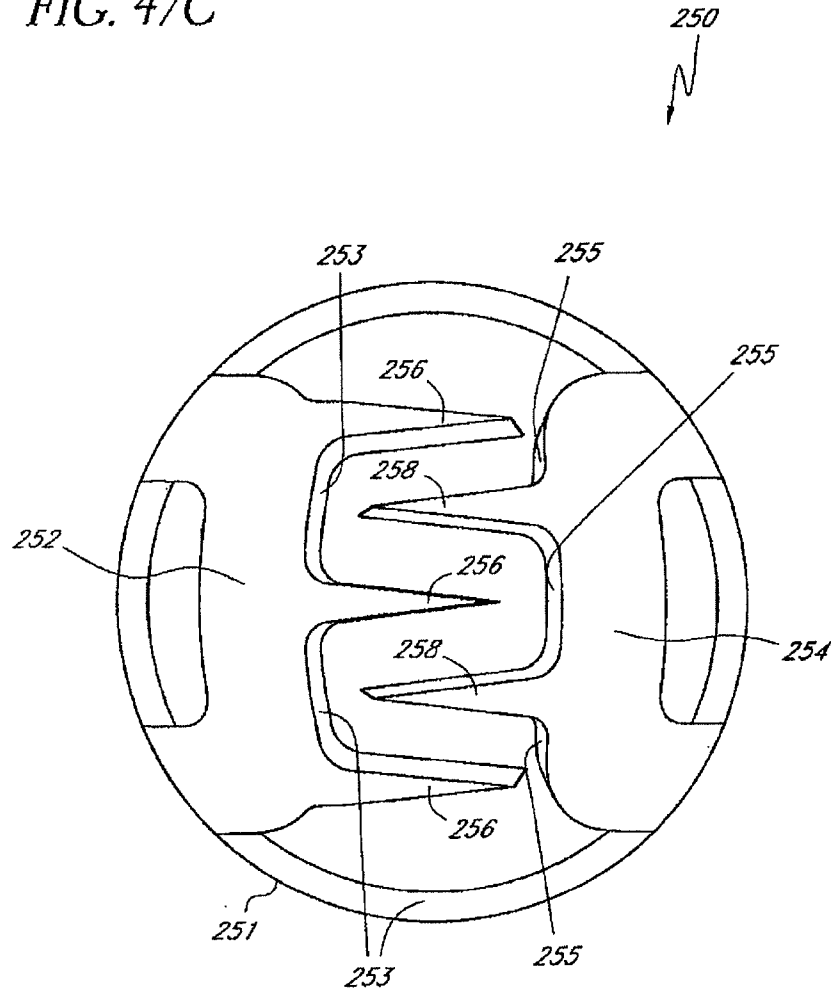

FIG. 47D

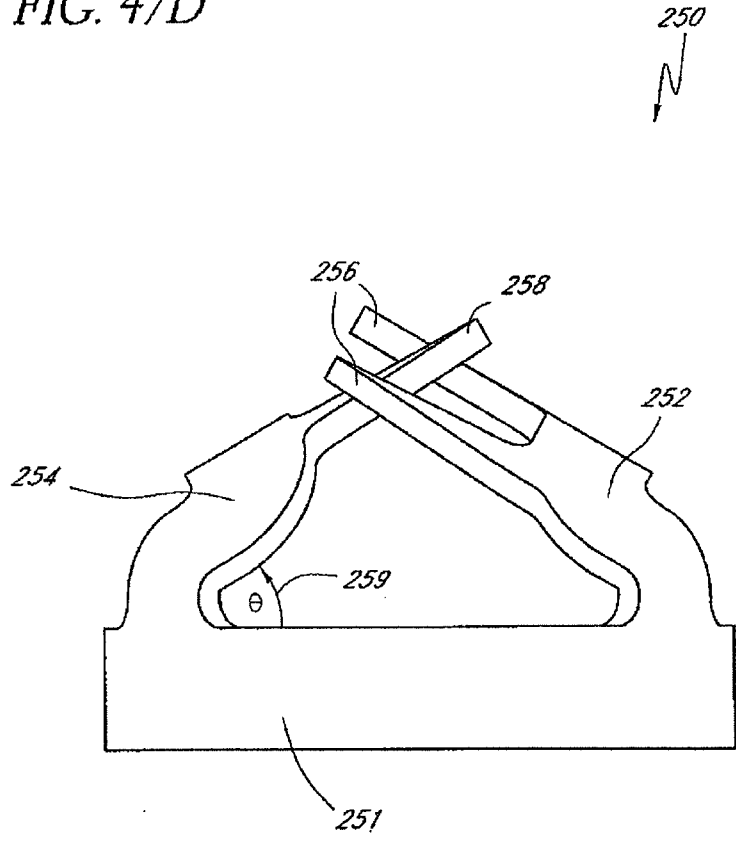

FIG. 48A

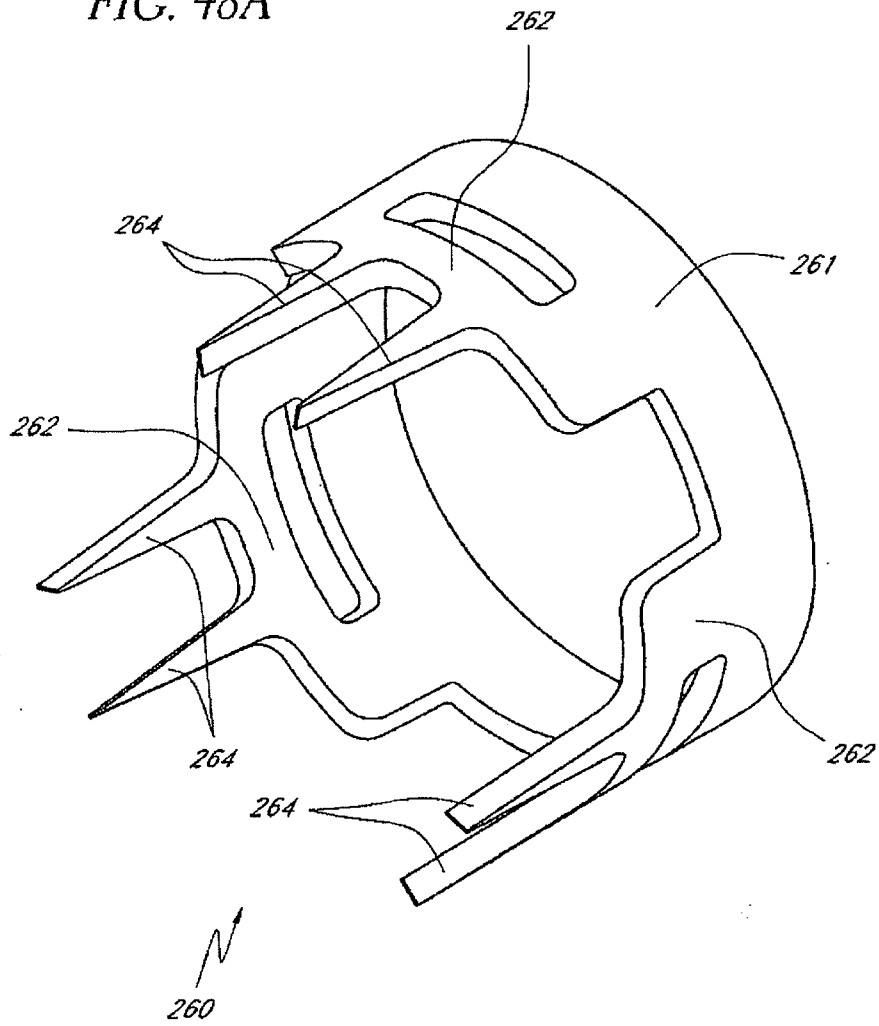

FIG. 48B

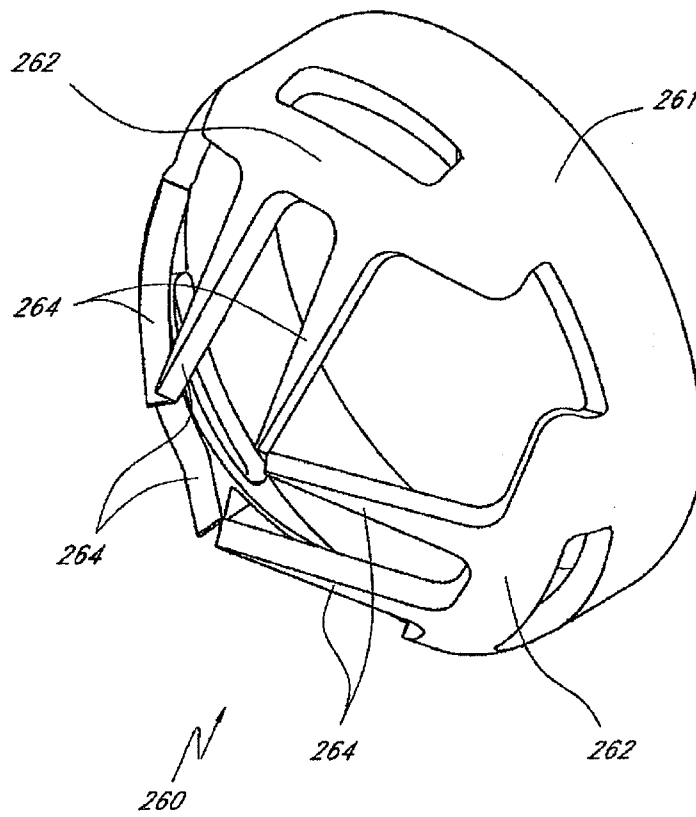

FIG. 49A

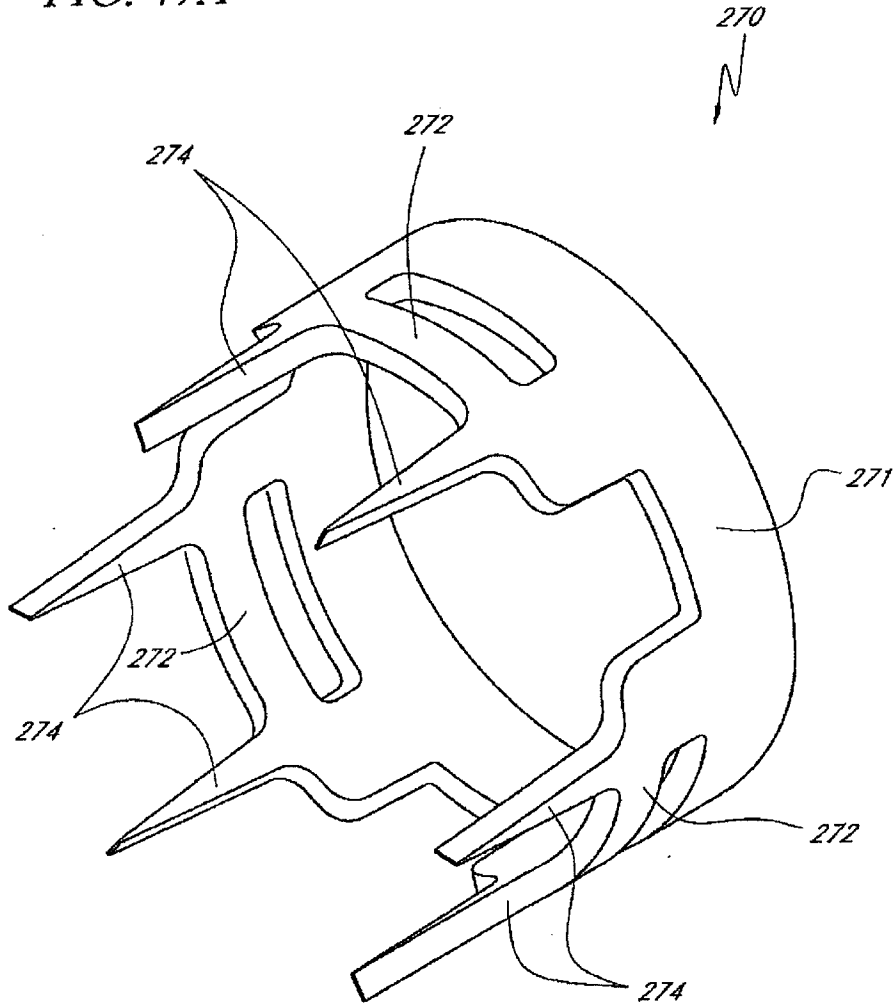

FIG. 49B

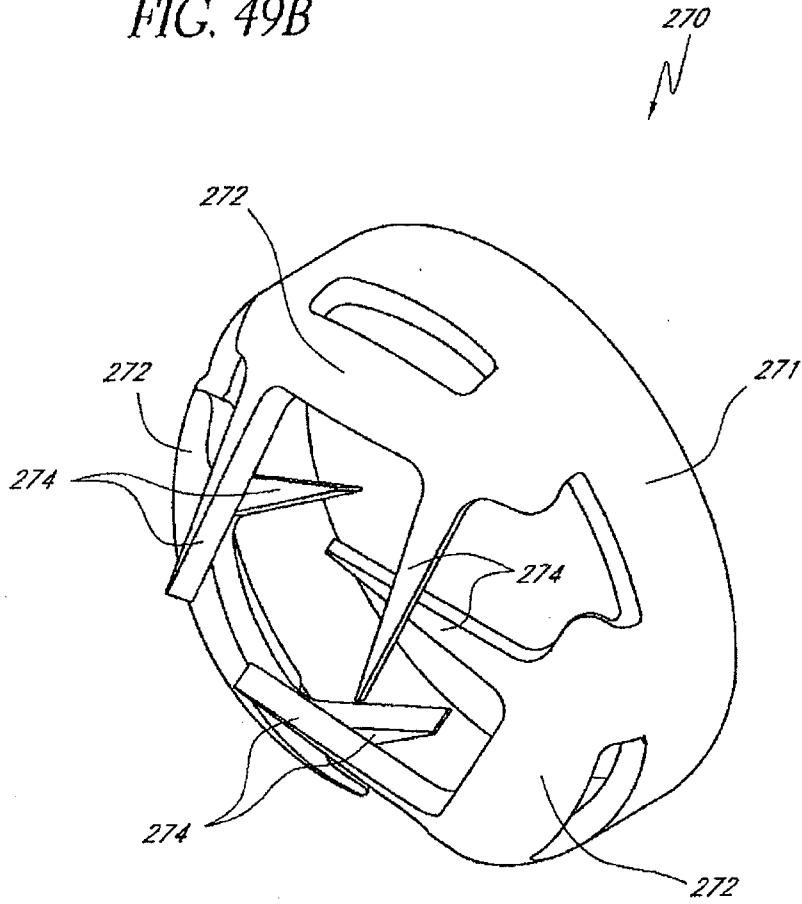

FIG. 50A

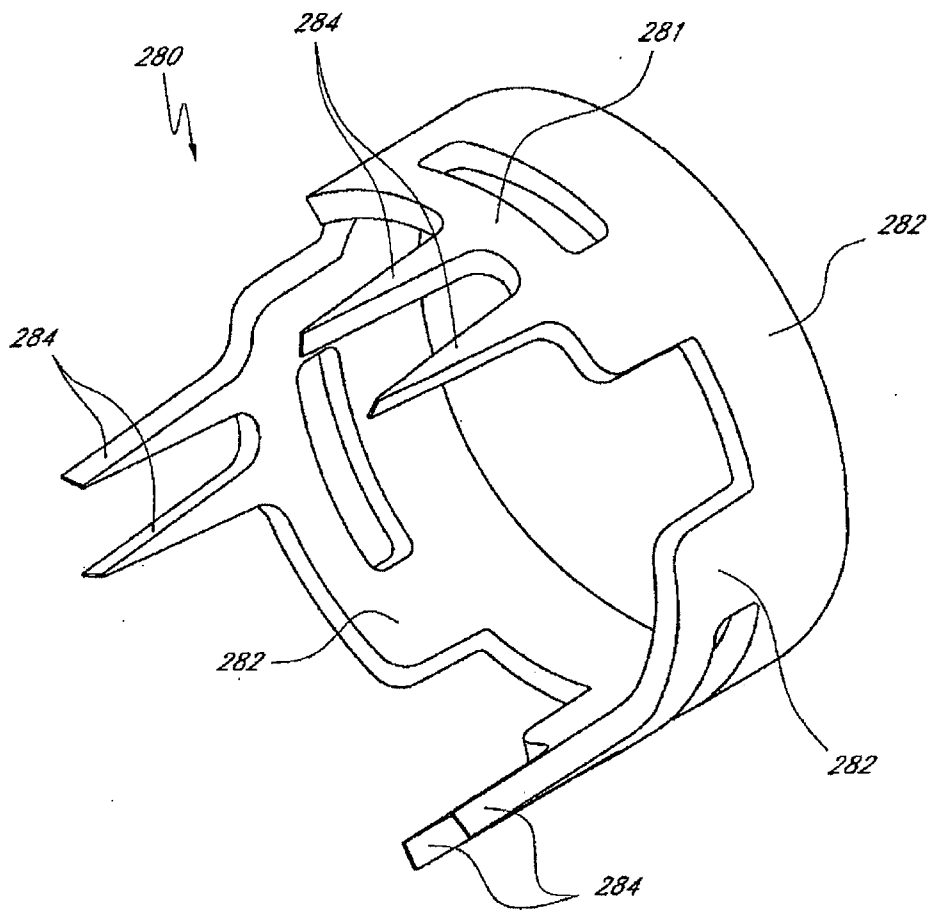



FIG. 51A

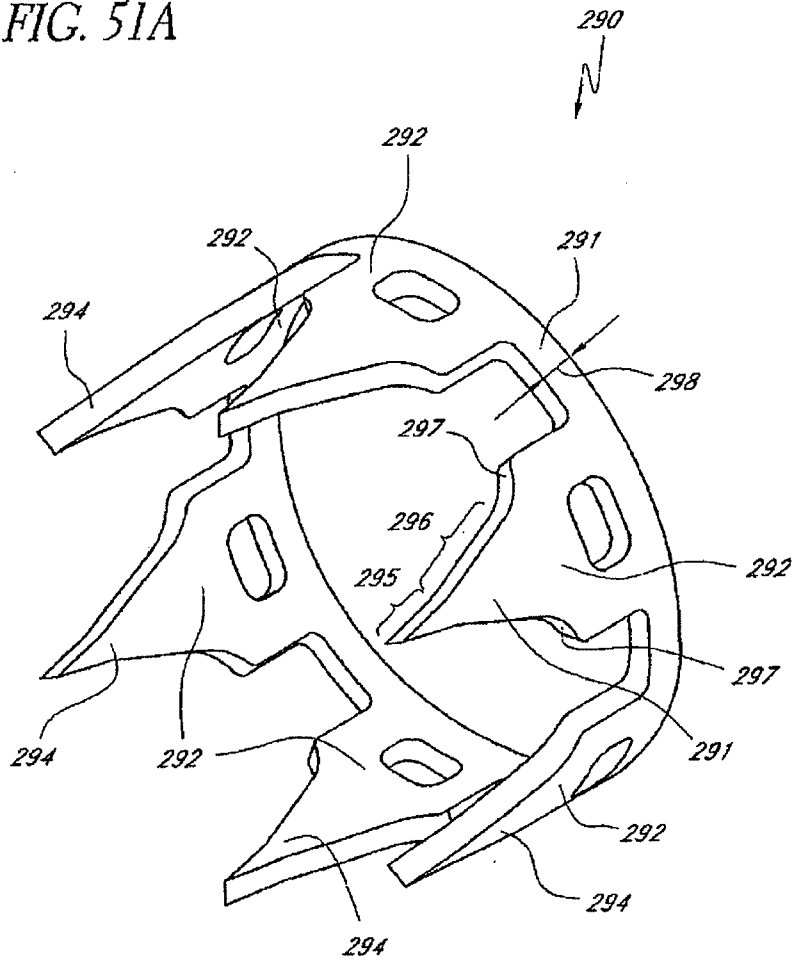

FIG. 51B

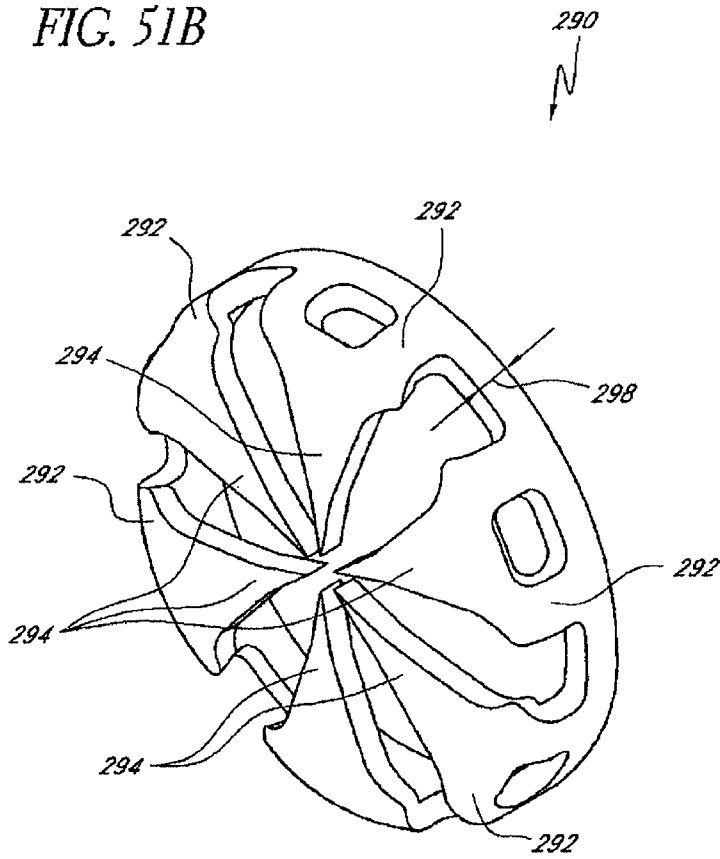

FIG. 51C

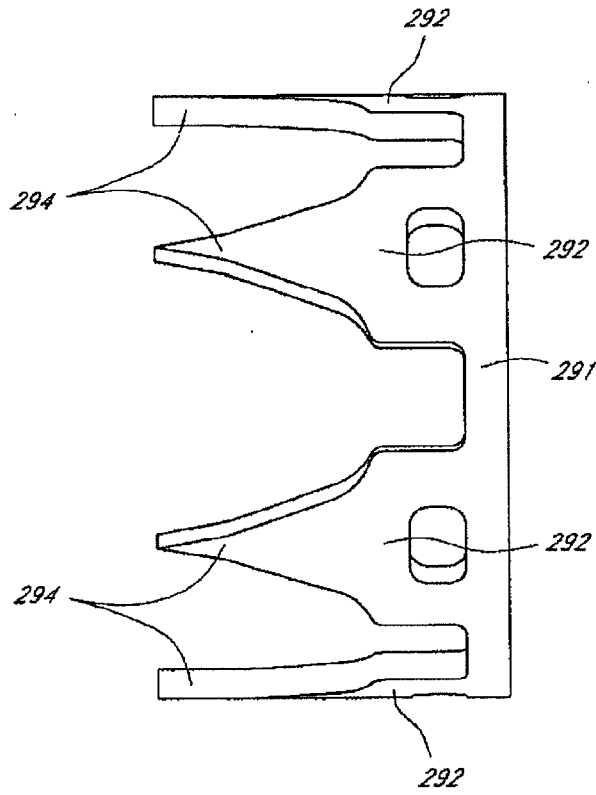

FIG. 51D

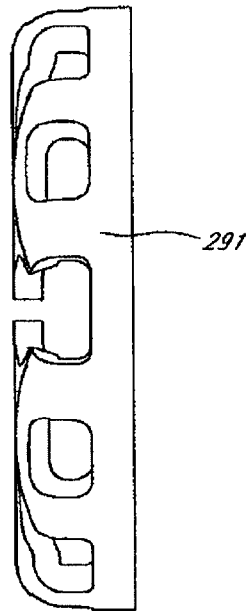
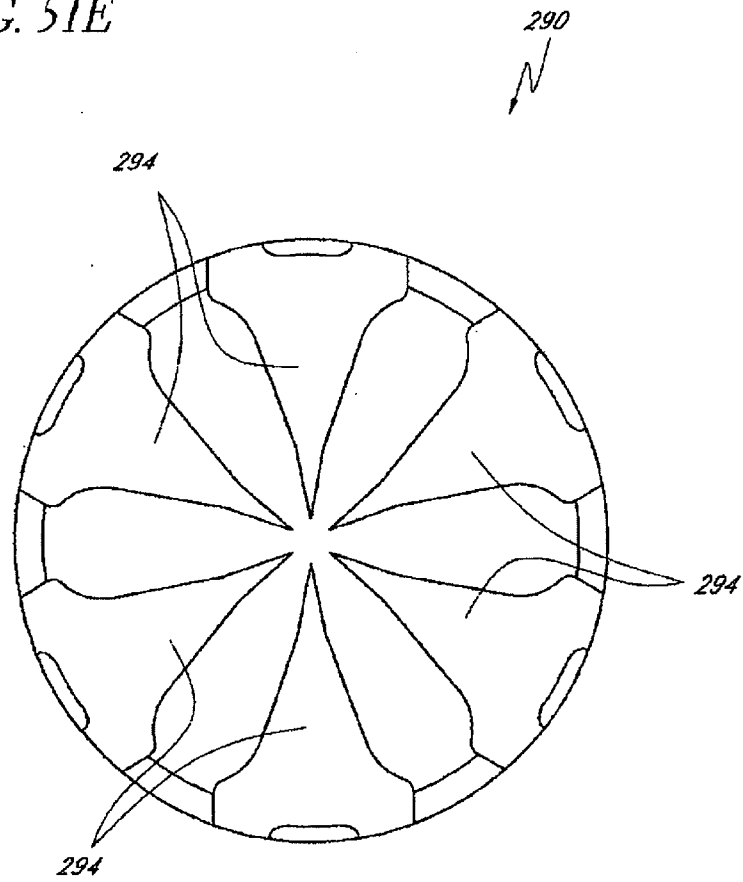

FIG. 51E



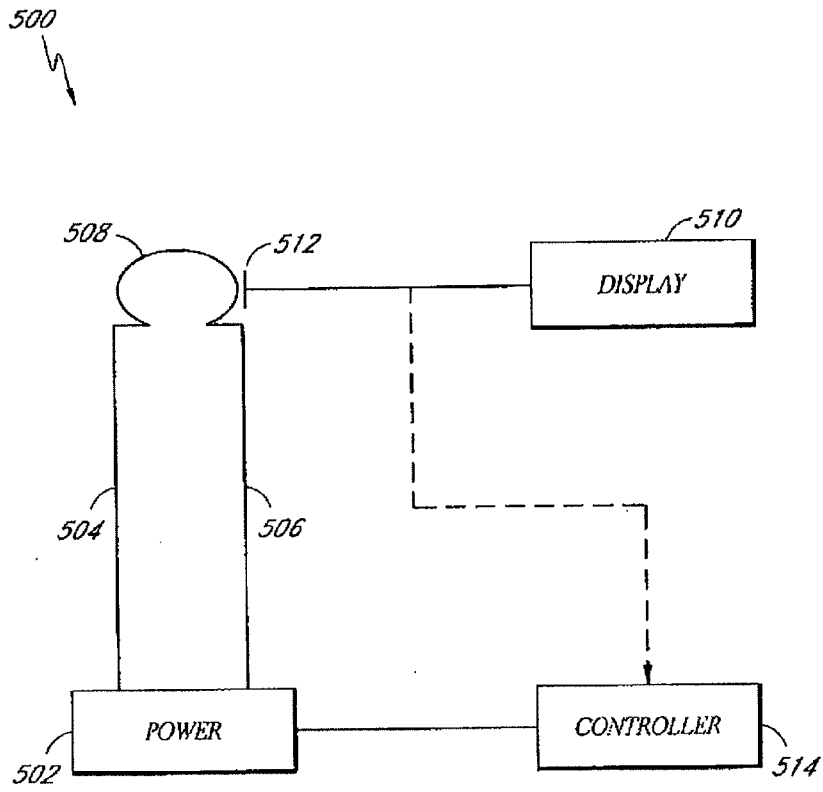

FIG. 52

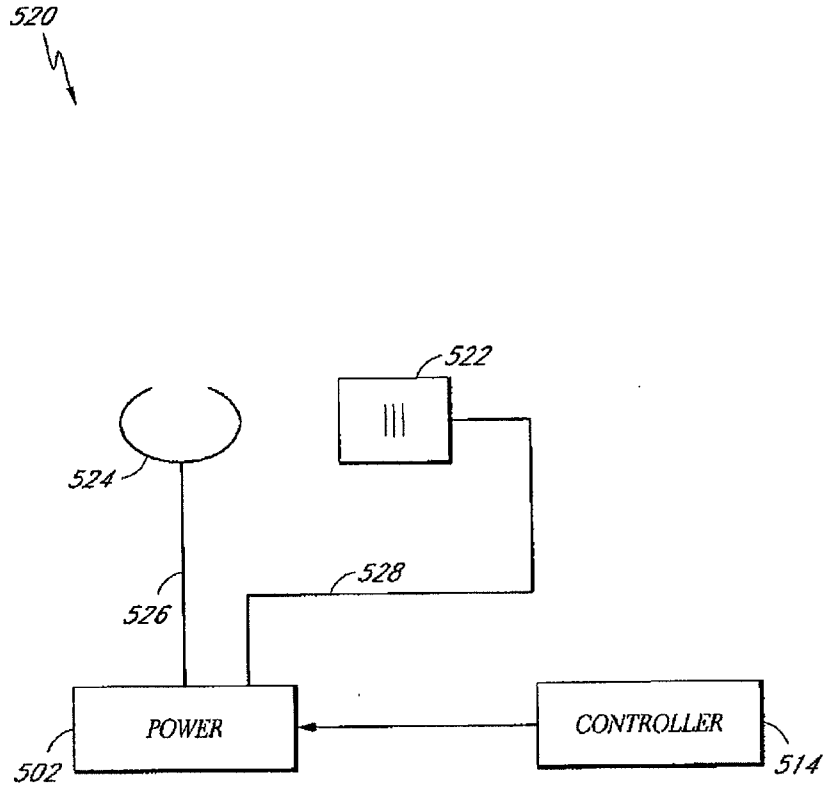

FIG. 53

FIG. 54

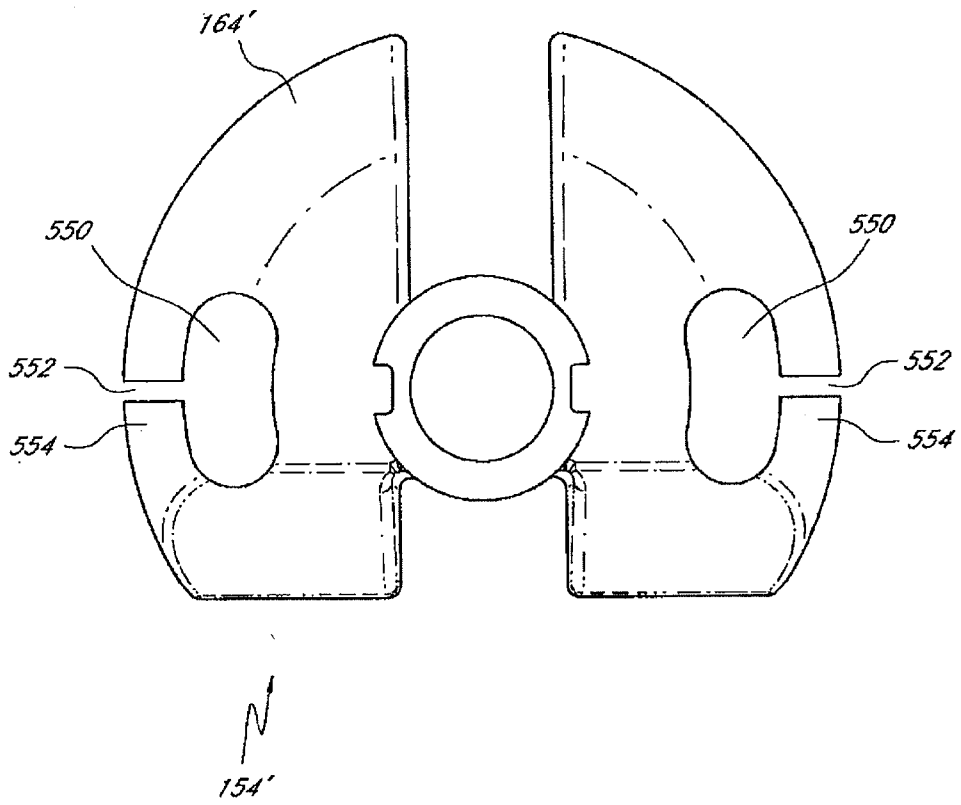
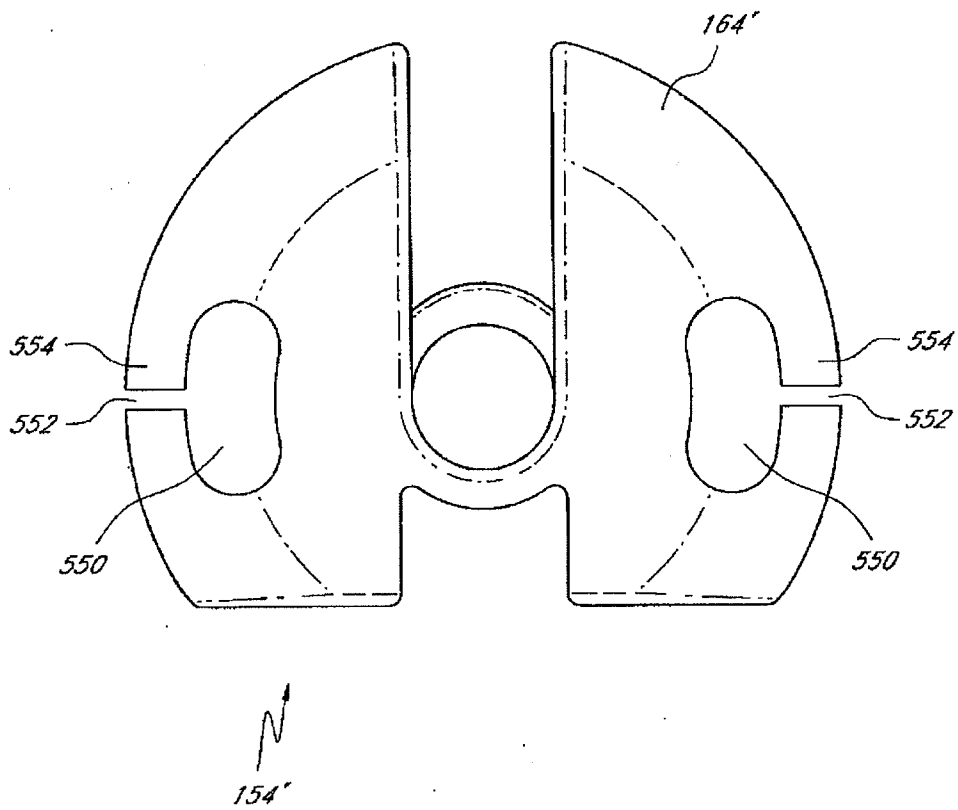

FIG. 55



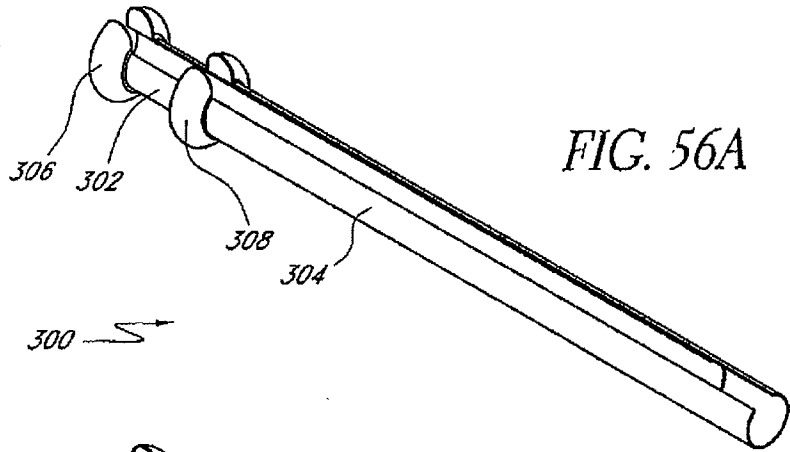

FIG. 56A

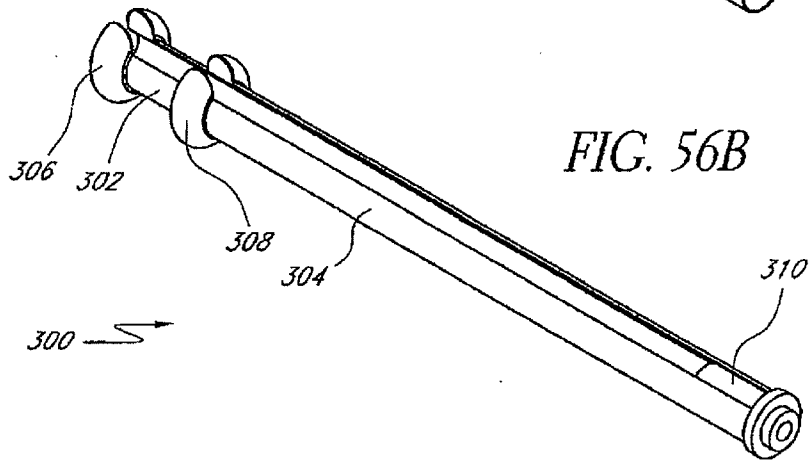

FIG. 56B

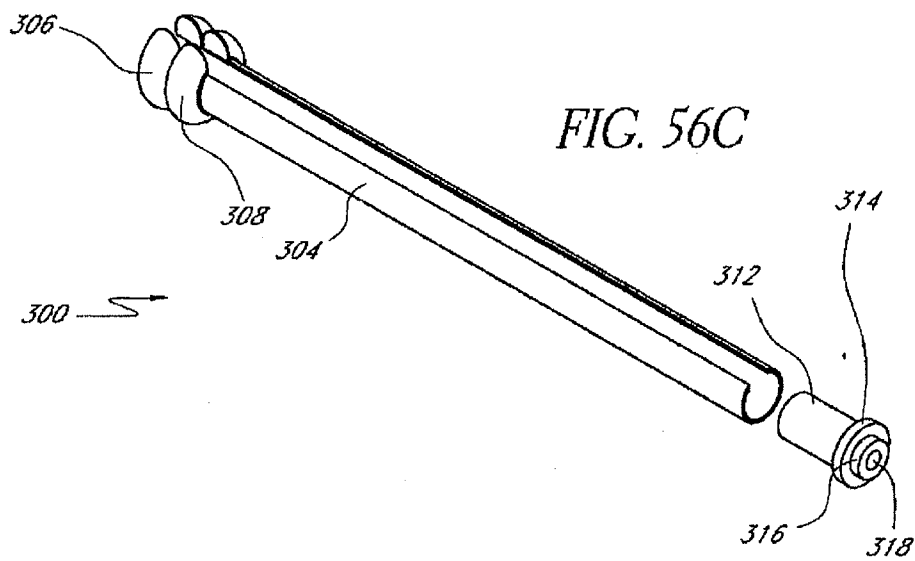

FIG. 56C

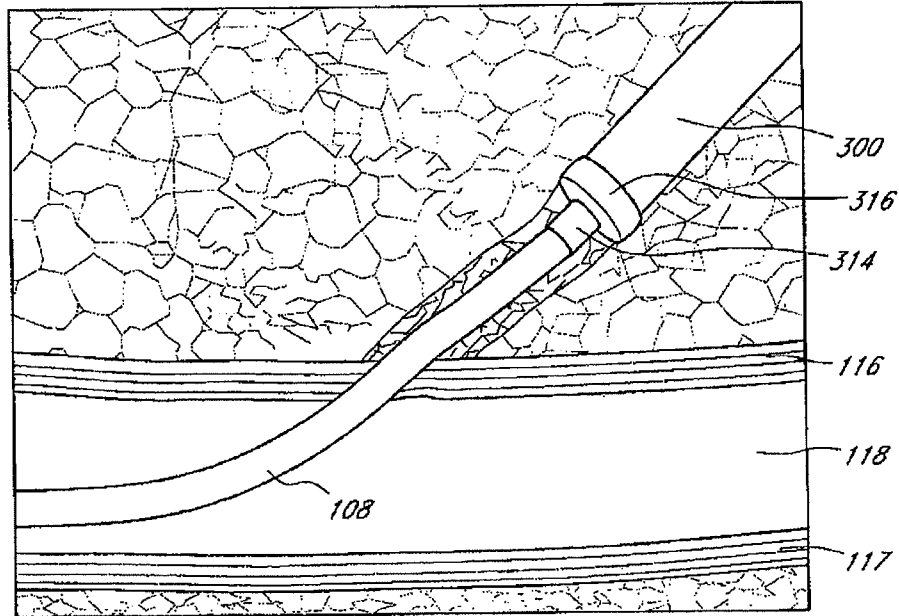

FIG. 57

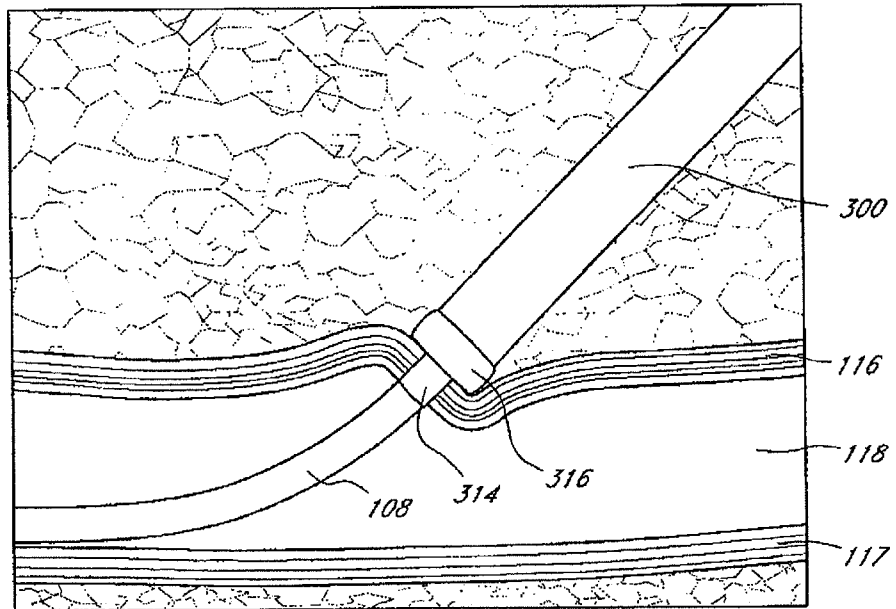

FIG. 58

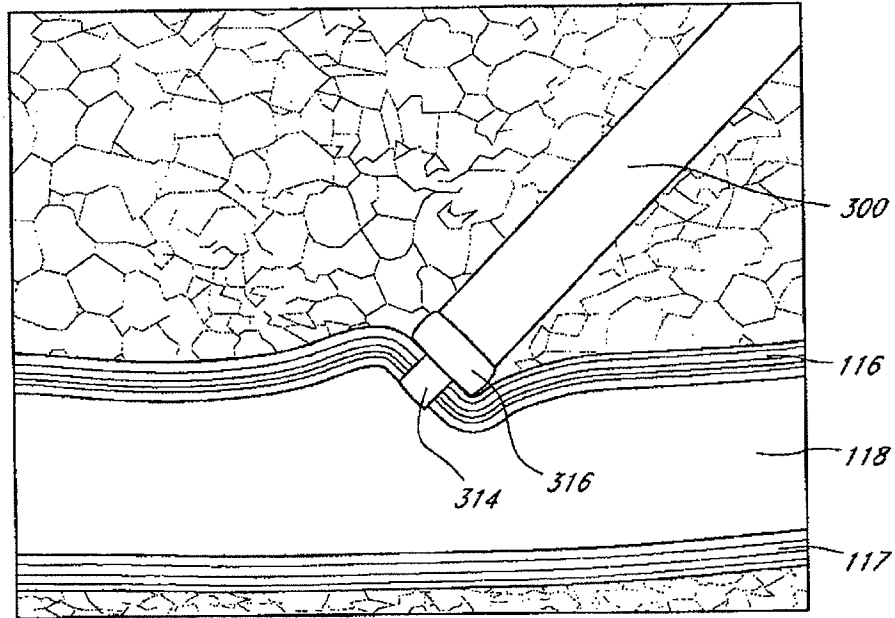

FIG. 59

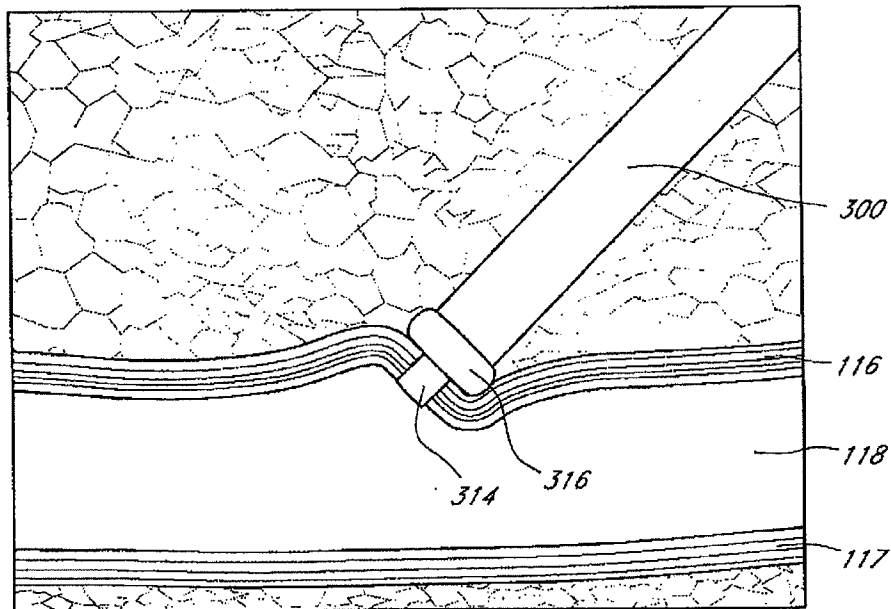

FIG. 60

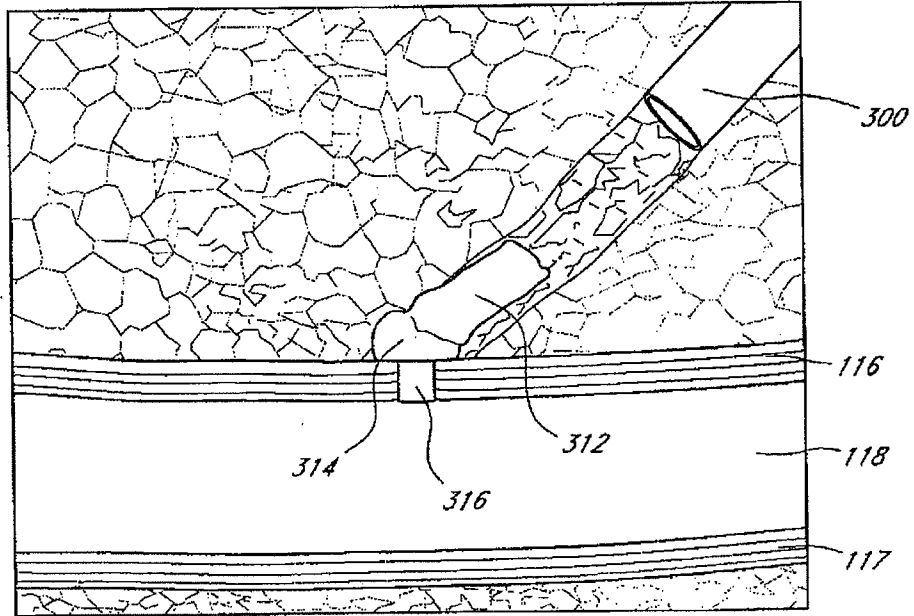

FIG. 61

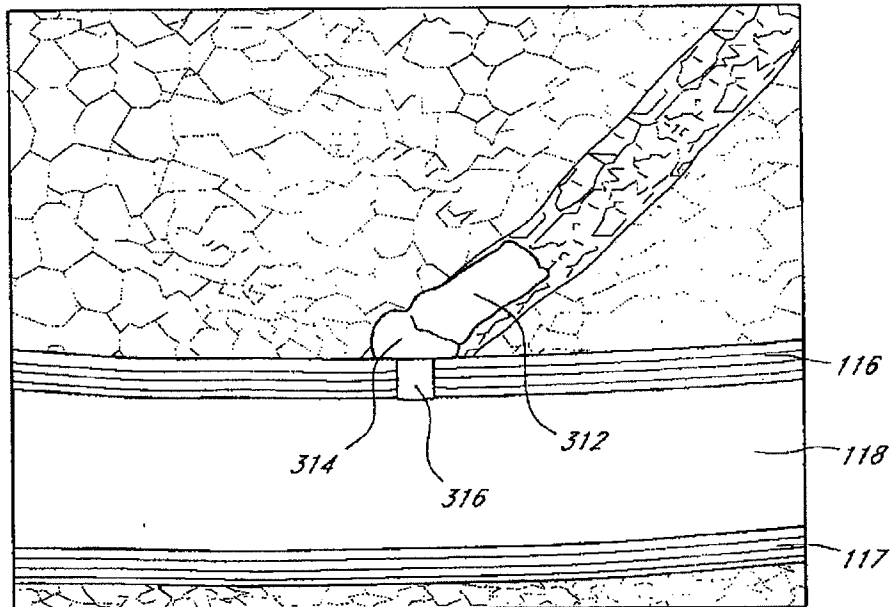

FIG. 62

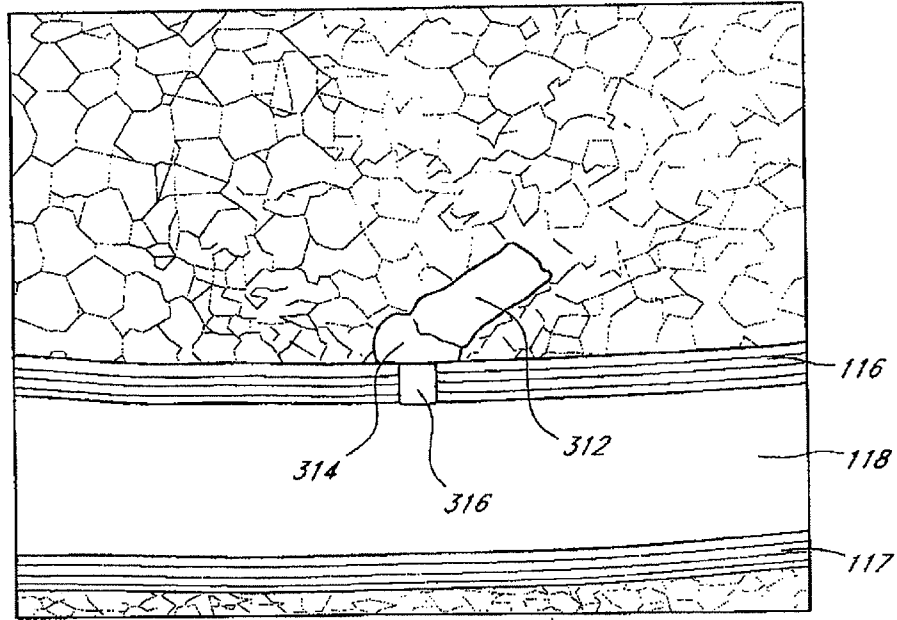
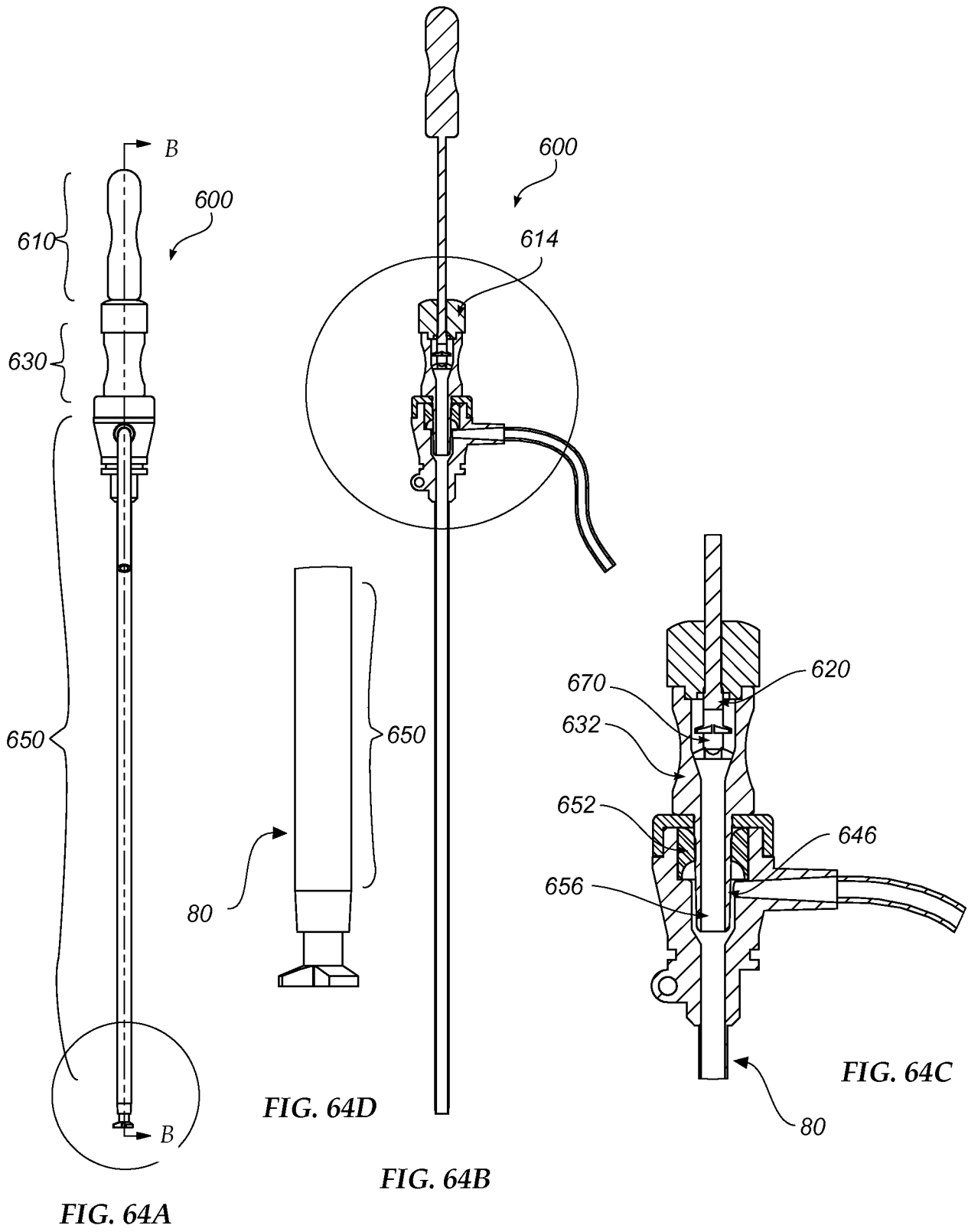

FIG. 63



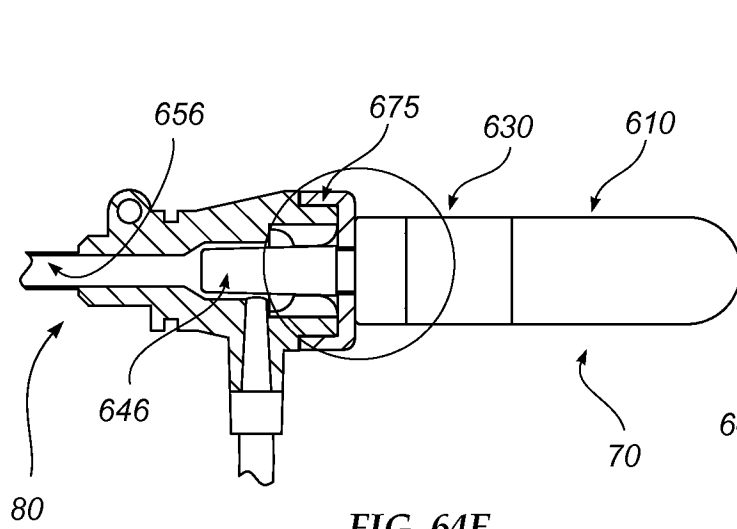

FIG. 64E

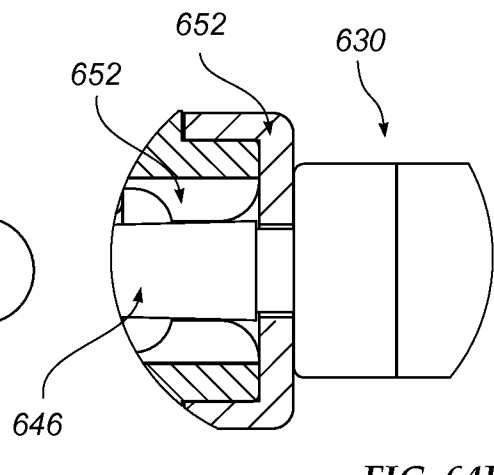

FIG. 64F

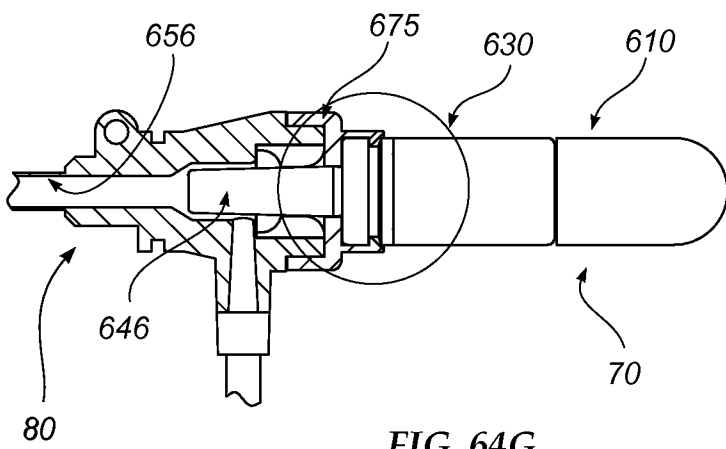

FIG. 64G

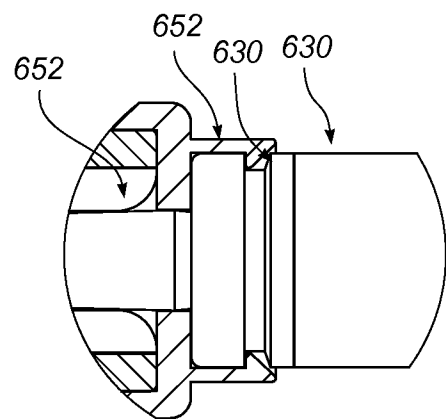

FIG. 64H

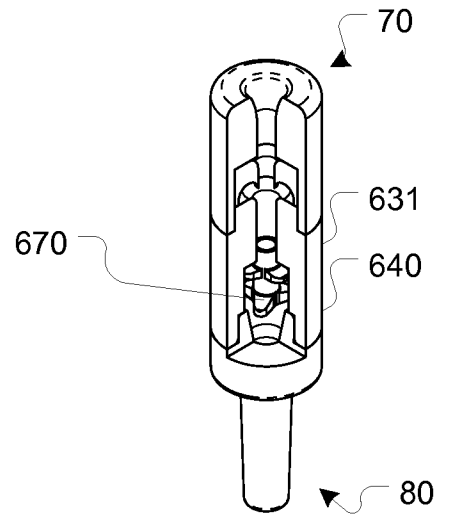

FIG. 65A

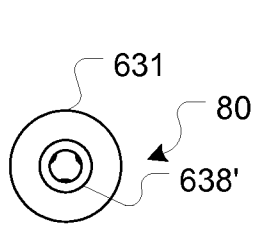

FIG. 65E

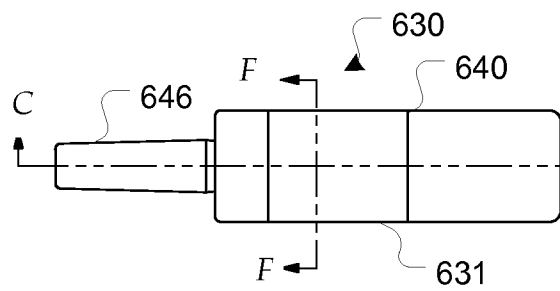

FIG. 65B

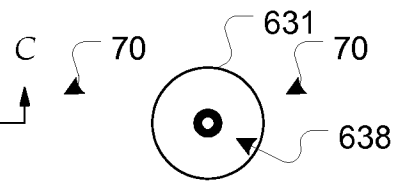

FIG. 65D

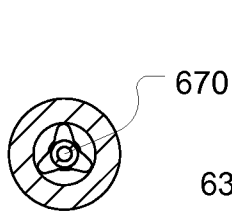

FIG. 65F

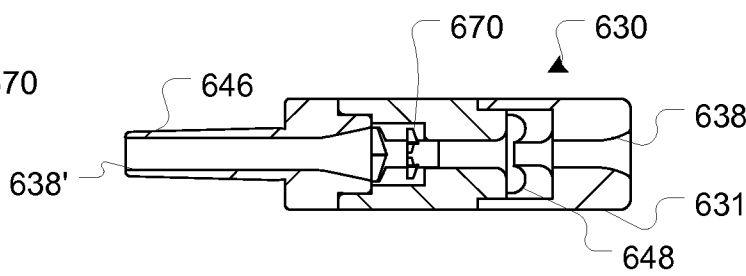

FIG. 65C

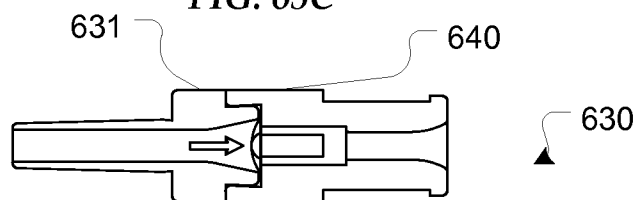
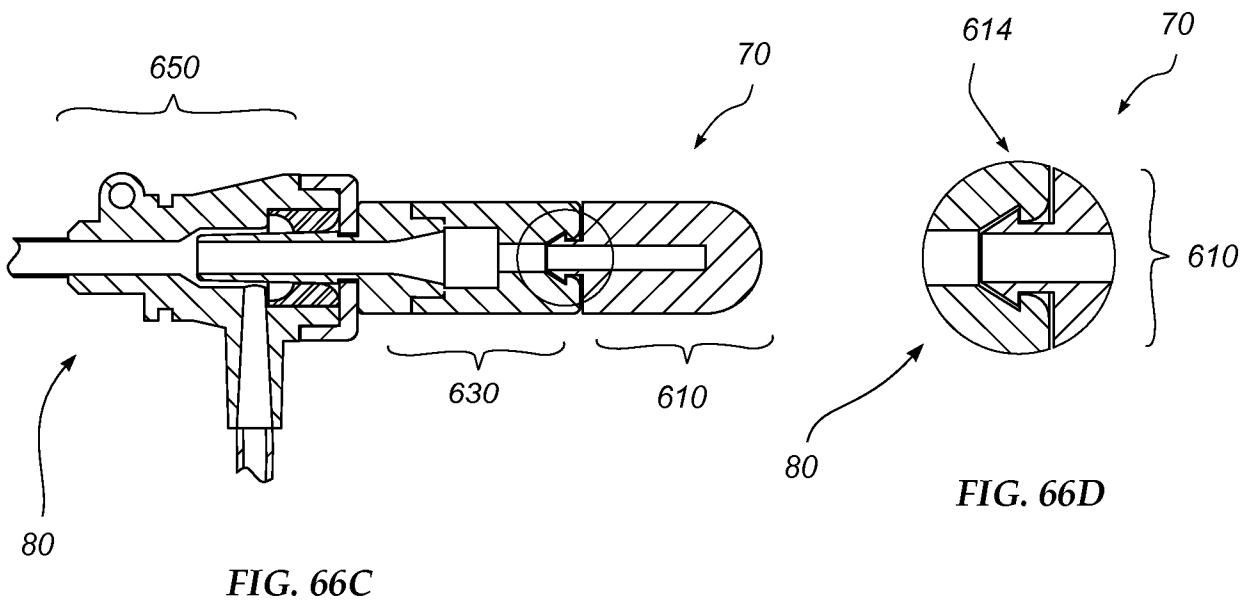
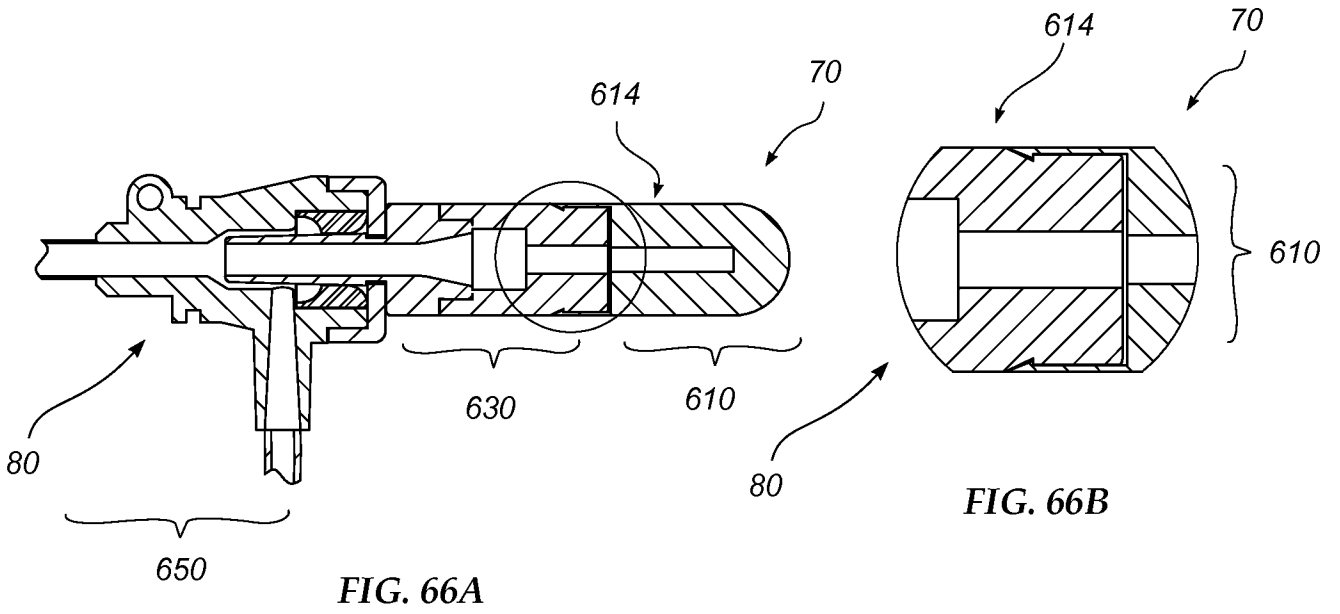

FIG. 65G



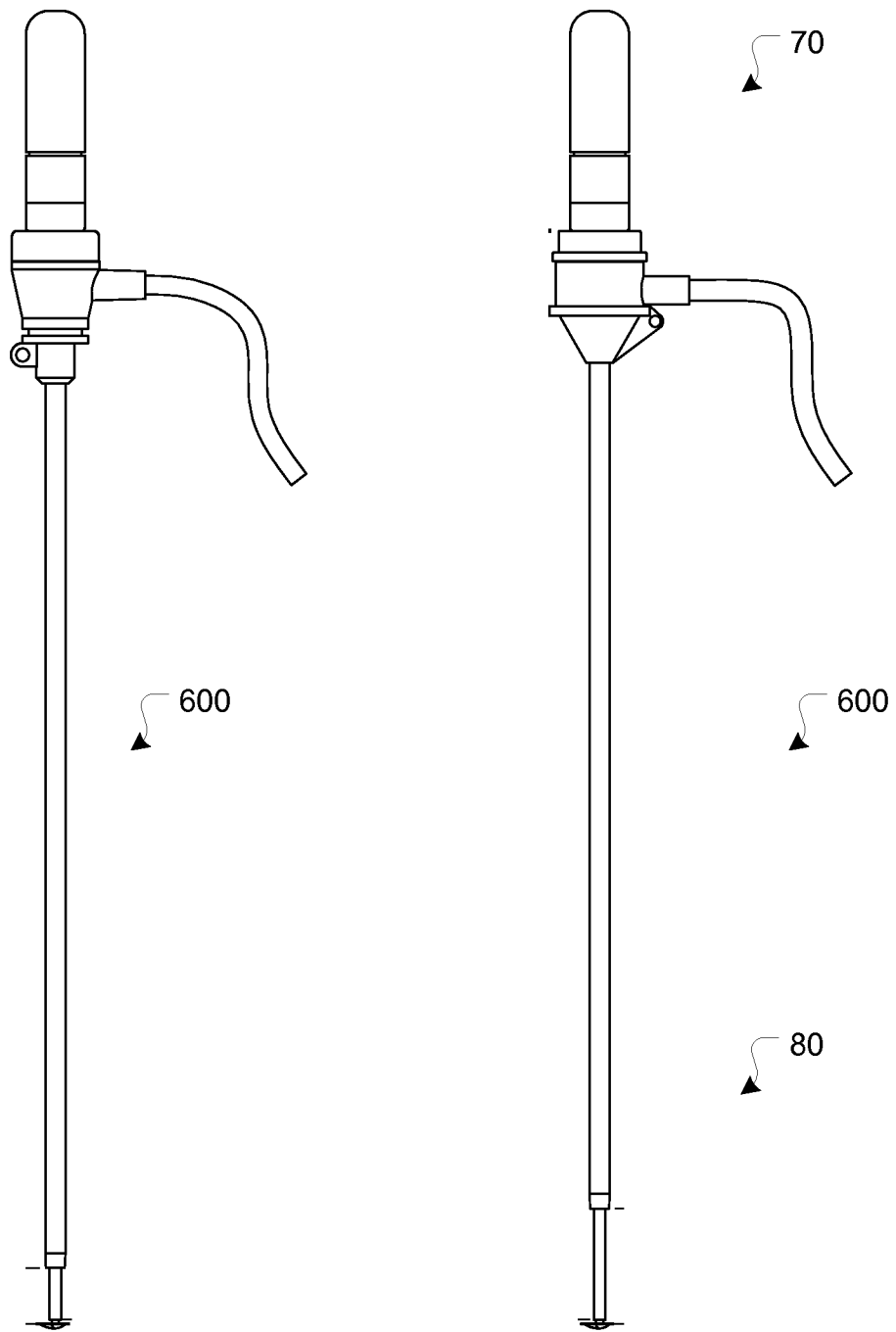
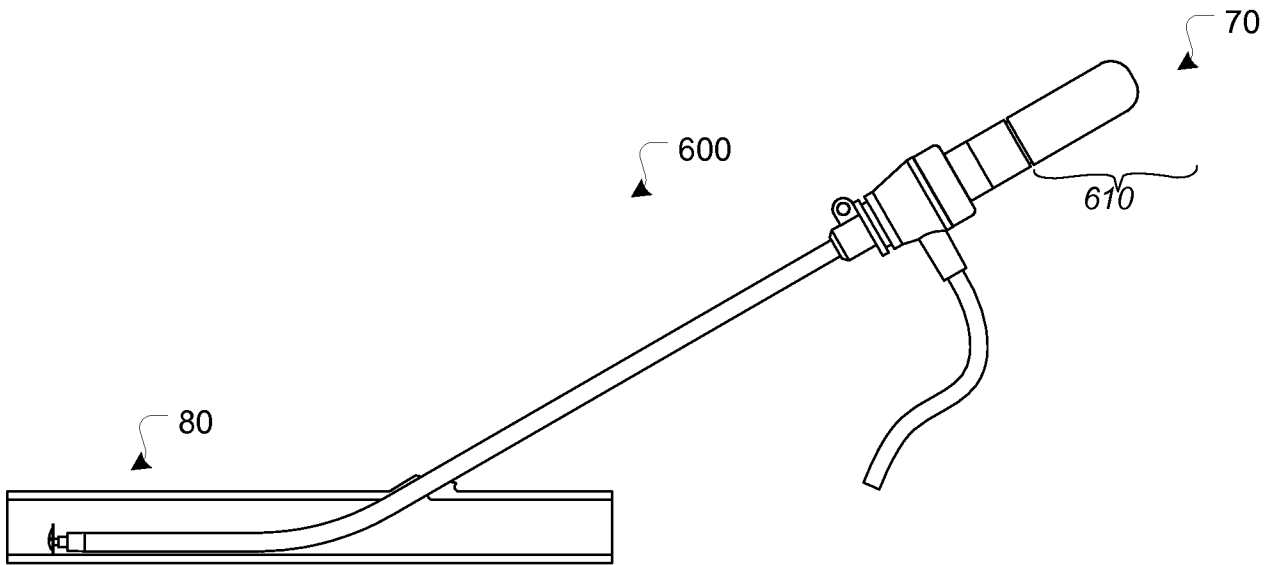
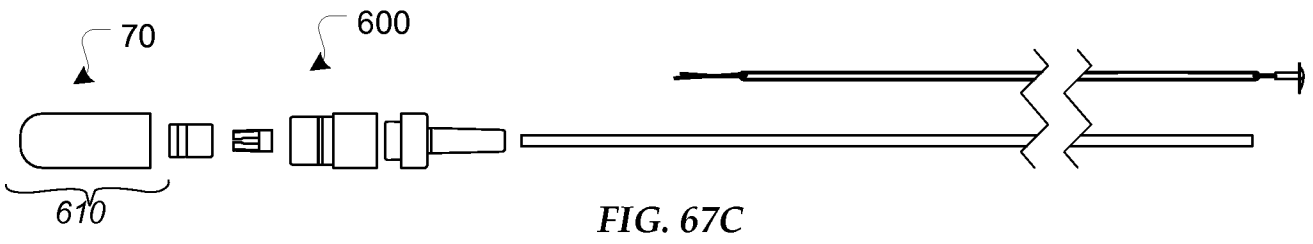
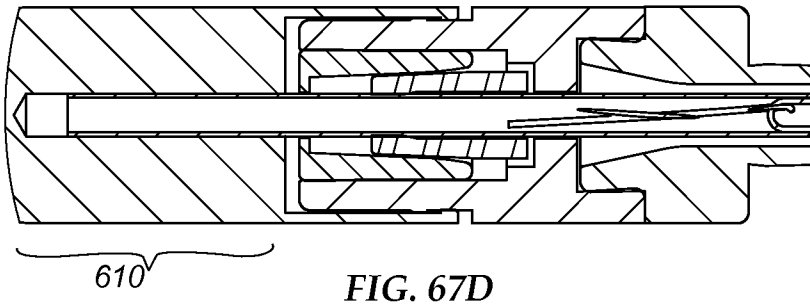
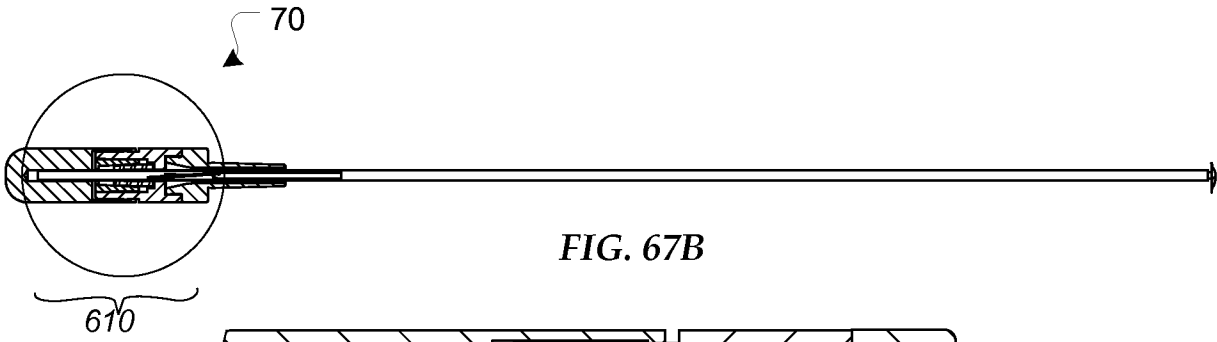

FIG. 67A



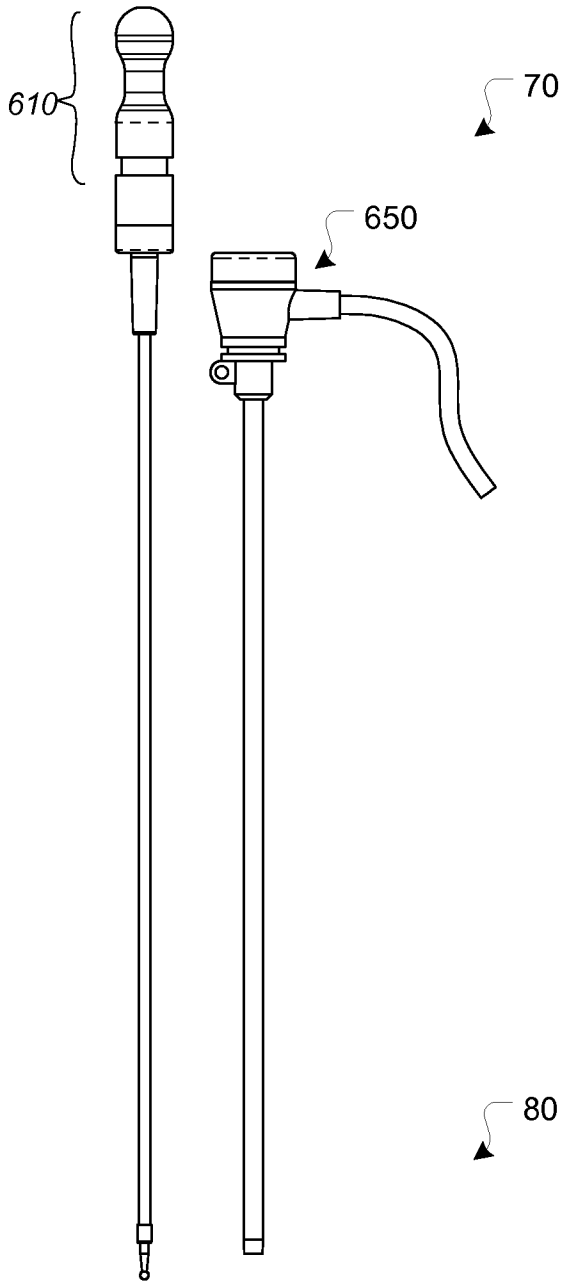

FIG. 68A

FIG. 68B

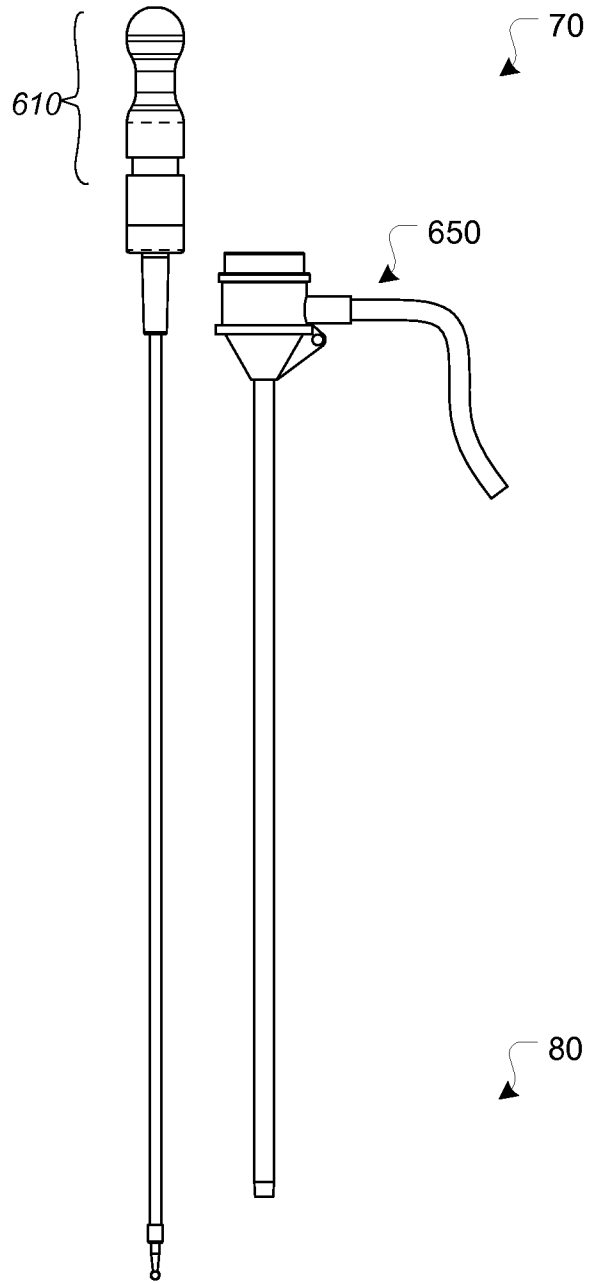

FIG. 69A

FIG. 69B

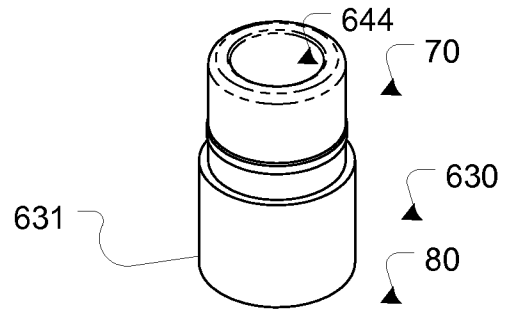

FIG. 70A

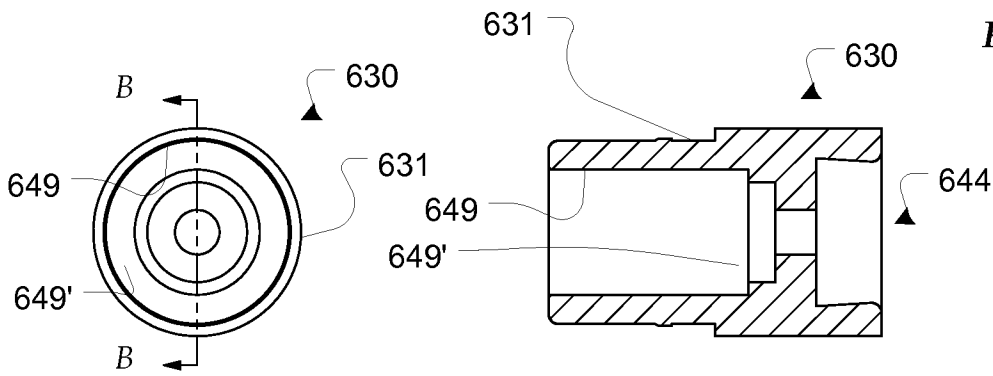

FIG. 70B

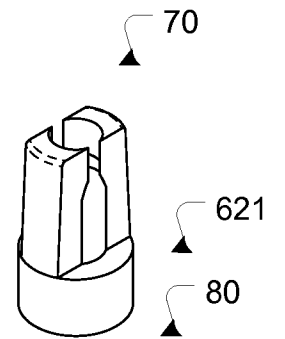

FIG. 70D

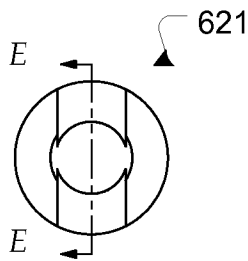

FIG. 70E

FIG. 70G

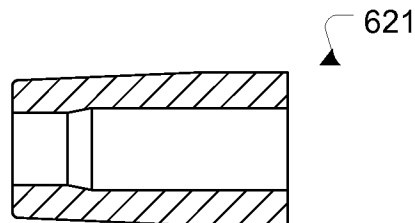

FIG. 70F

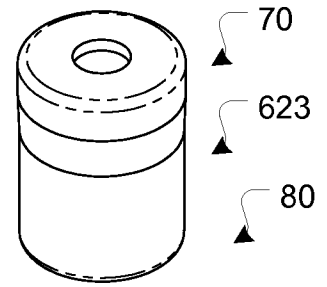

FIG. 71A



FIG. 71B

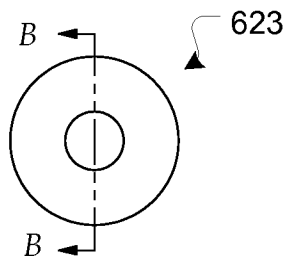

FIG. 71C

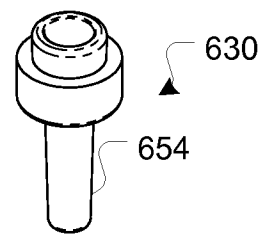

FIG. 72A

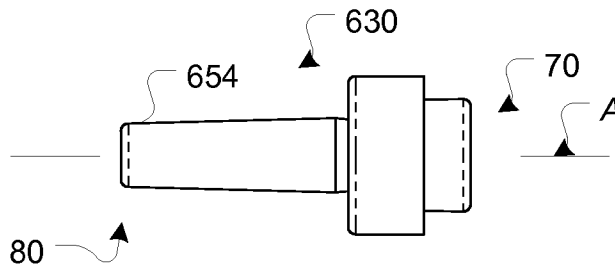

FIG. 72D

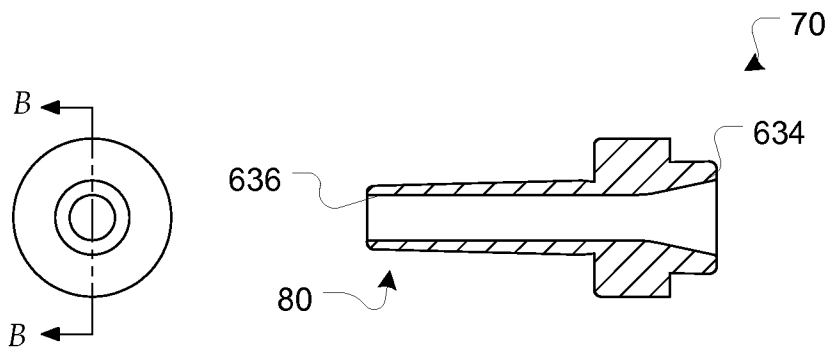

FIG. 72B

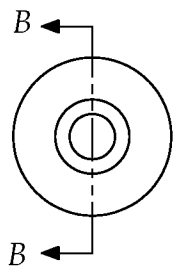

FIG. 72C

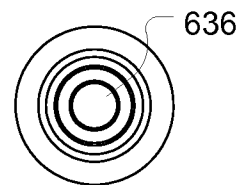

FIG. 72E

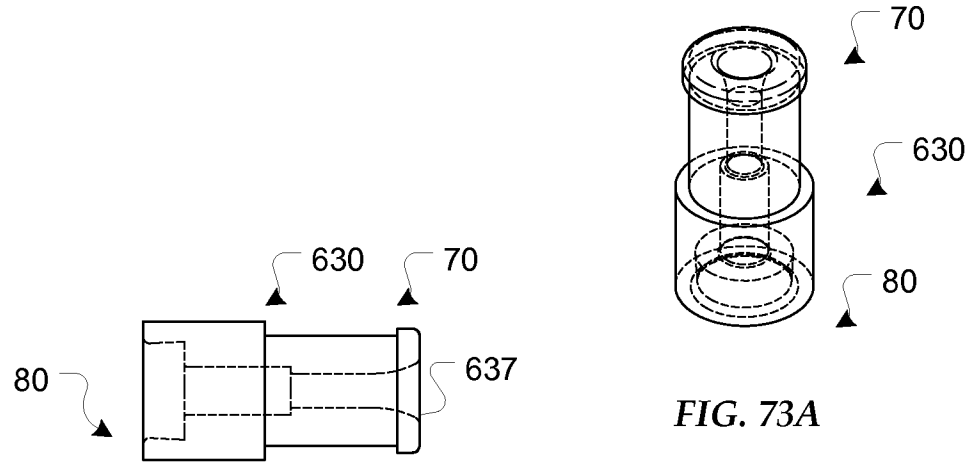

FIG. 73D

FIG. 73A

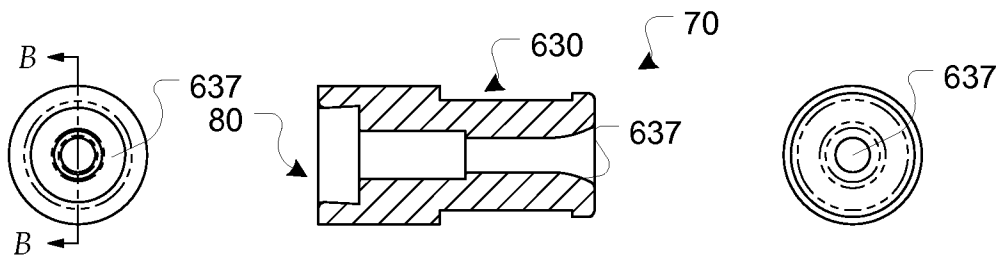

FIG. 73C

FIG. 73b

FIG. 73E

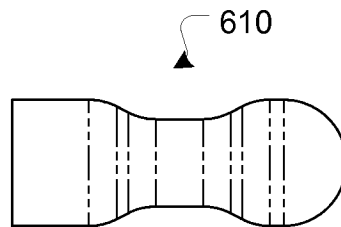

FIG. 74C

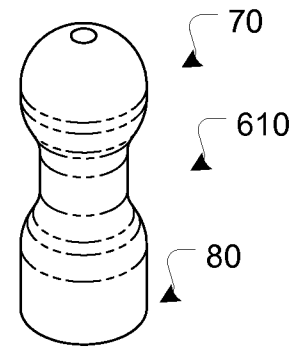

FIG. 74A

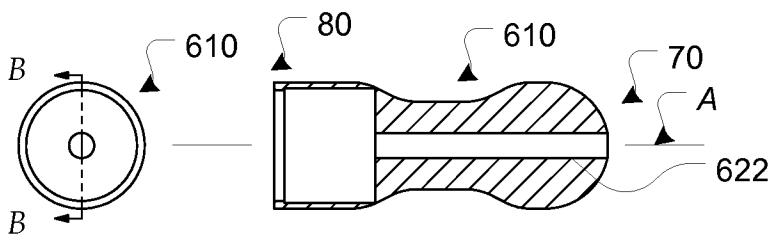

FIG. 74D

FIG. 74B

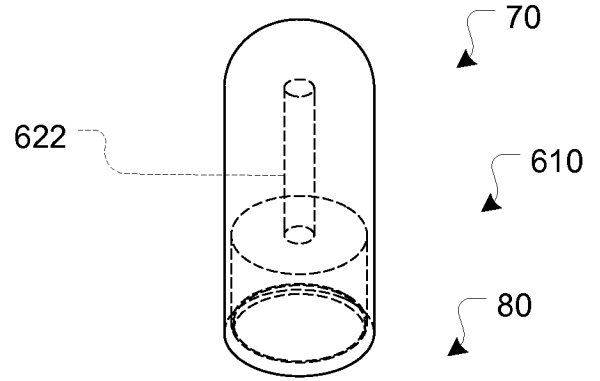

FIG. 75A

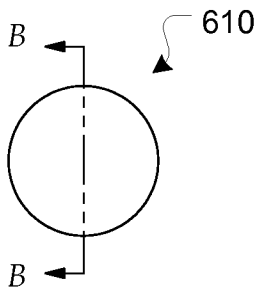

FIG. 75C

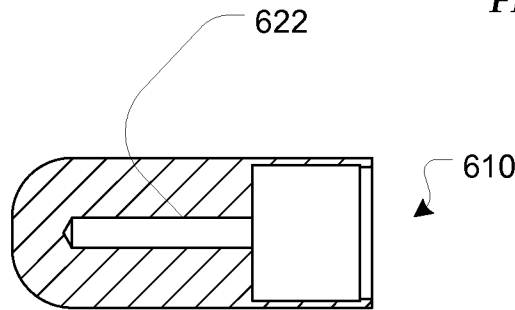

FIG. 75B

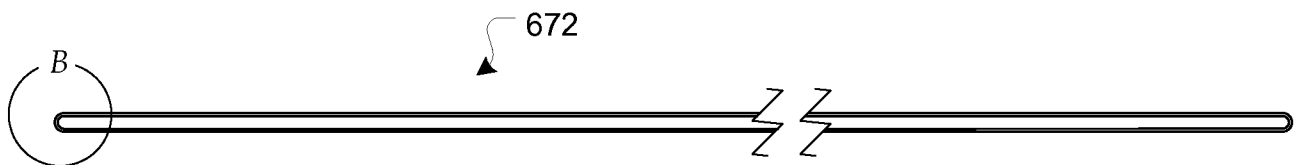

FIG. 76A

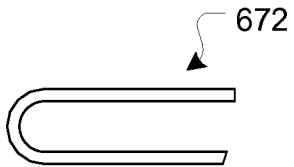

FIG. 76B

FIG. 77A

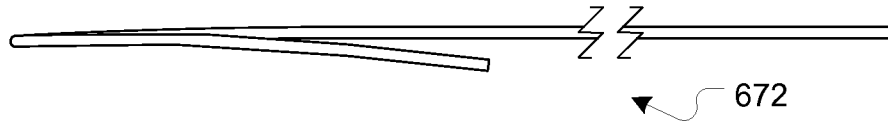

FIG. 77B

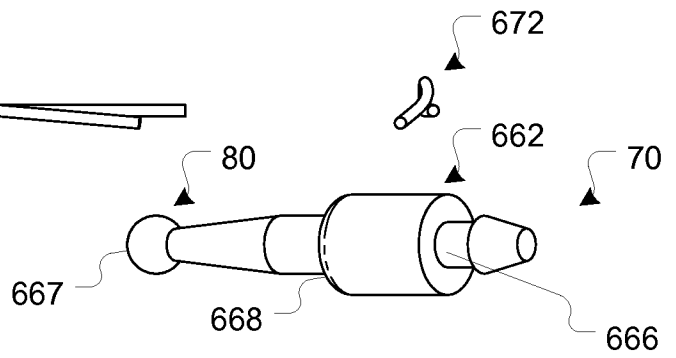
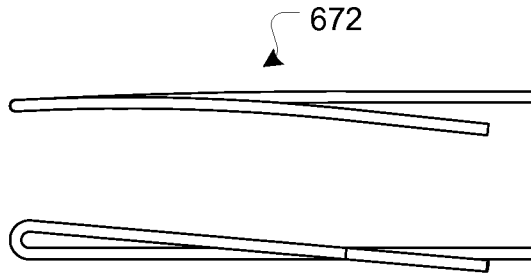

FIG. 78A

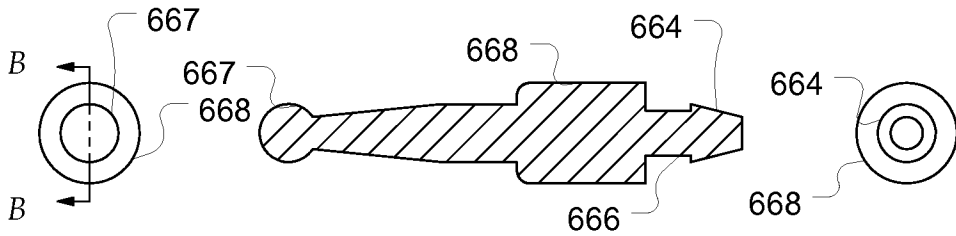

FIG. 78D

FIG. 78B

FIG. 78C

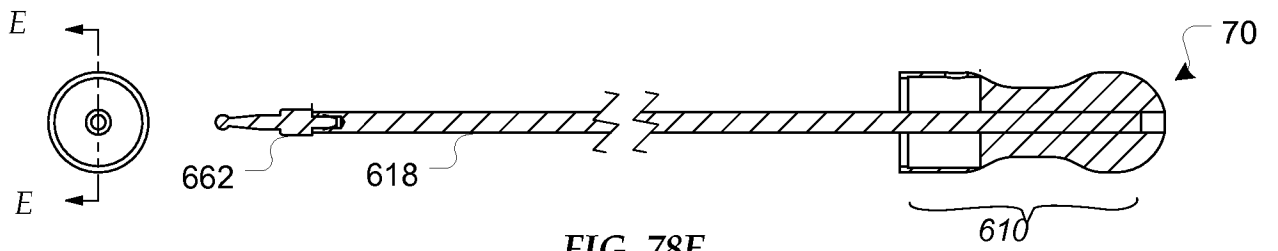

FIG. 78E

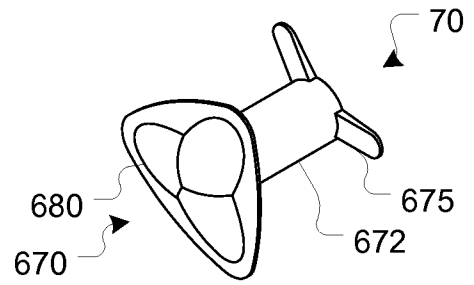

FIG. 79A

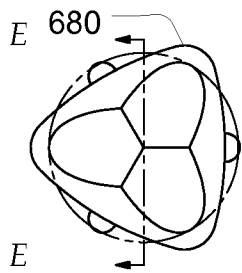

FIG. 79B

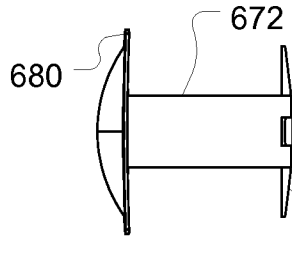

FIG. 79D

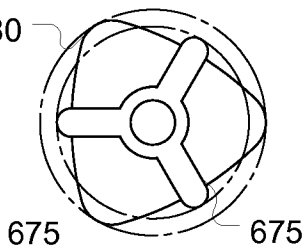

FIG. 79C

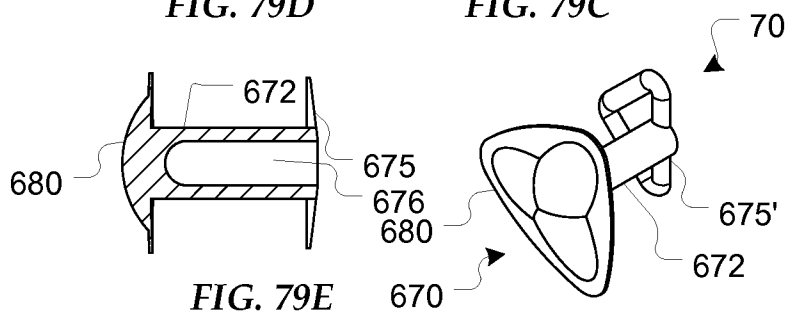

FIG. 79E

FIG. 79F

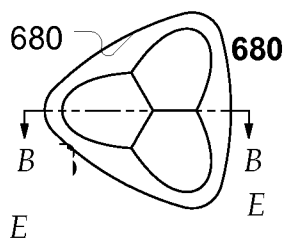

FIG. 79G

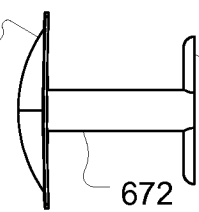

FIG. 79H

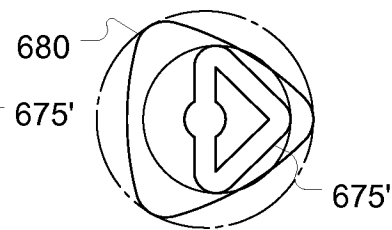

FIG. 79I

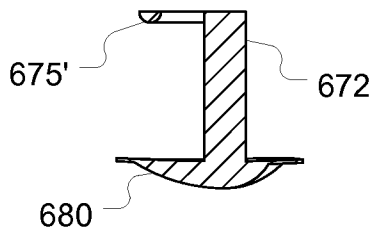

FIG. 79J

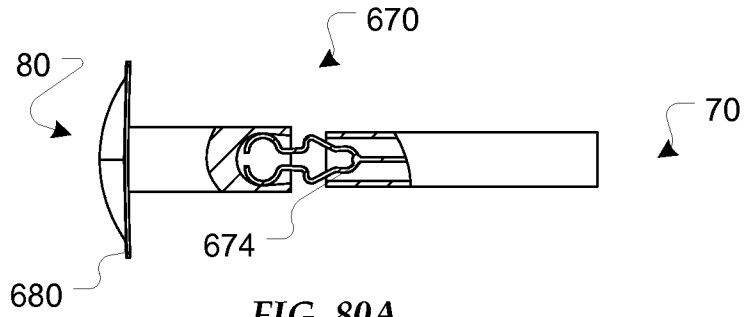
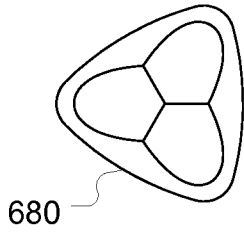

FIG. 80A

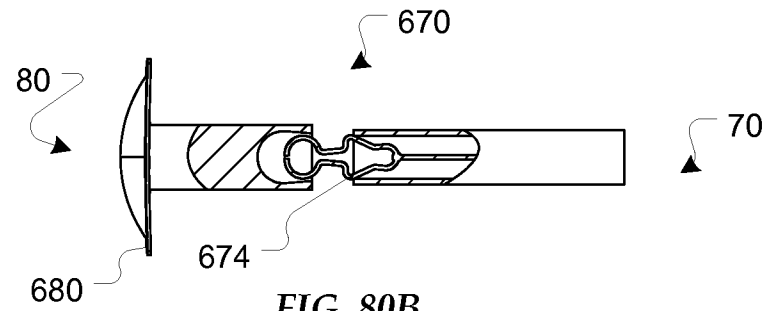
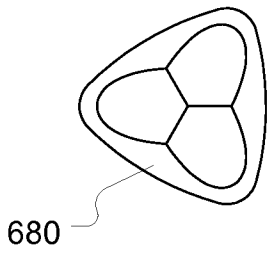

FIG. 80B

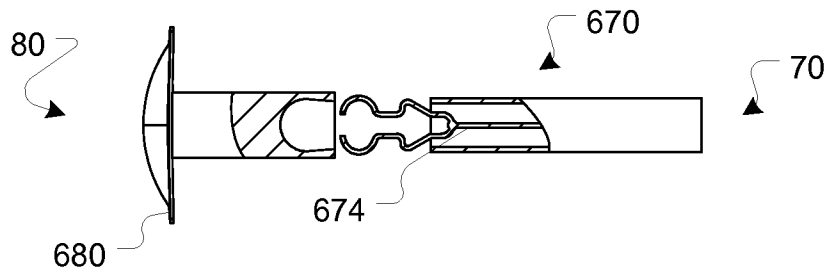
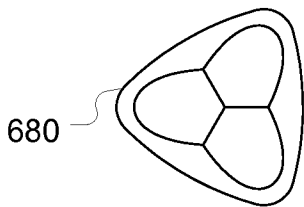

FIG. 80C

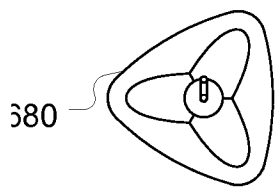

FIG. 81A

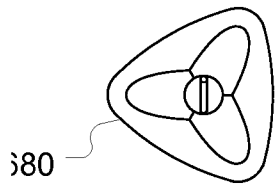
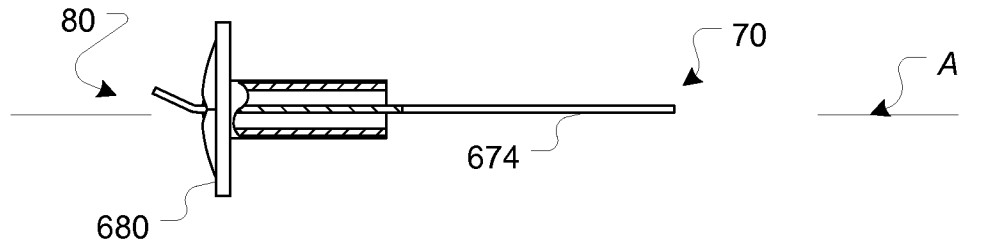

FIG. 81B

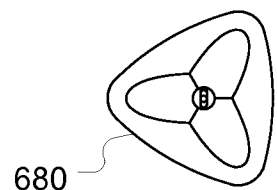
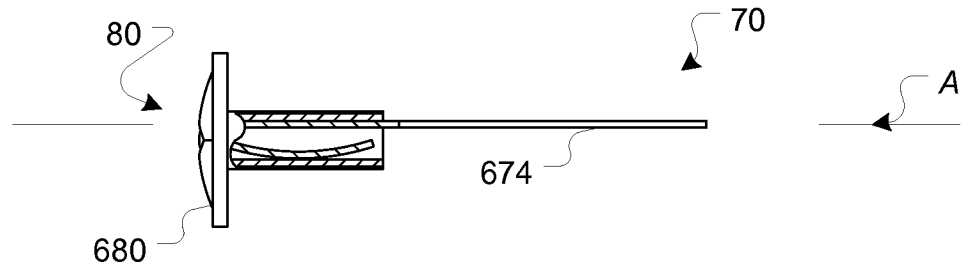

FIG. 81C

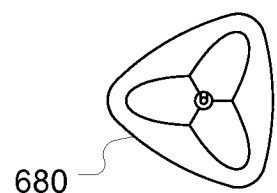
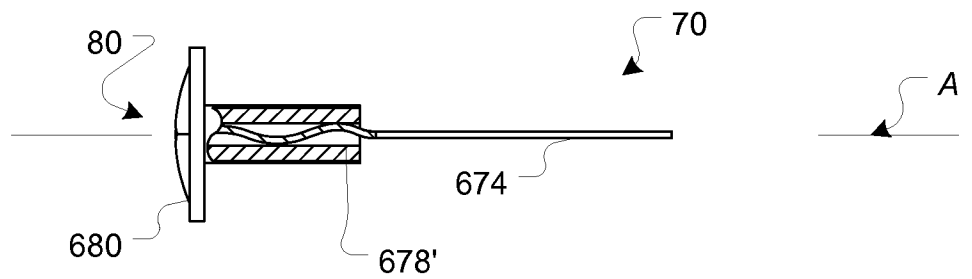
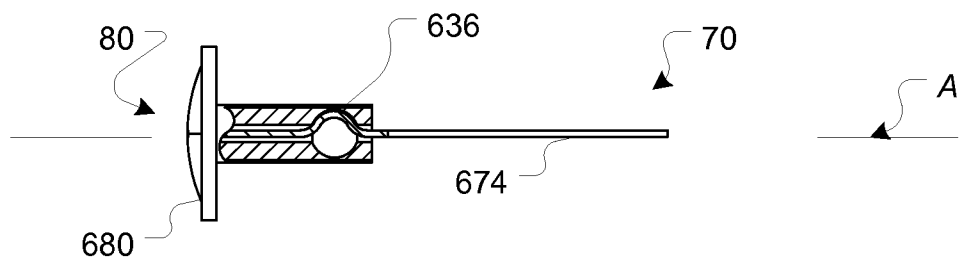

FIG. 81D



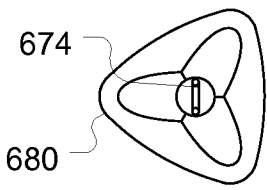

FIG. 81E

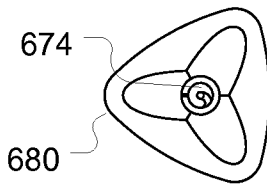

FIG. 81F

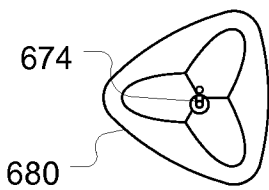

FIG. 81G

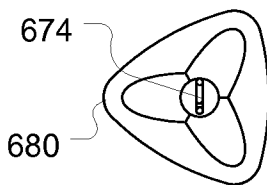
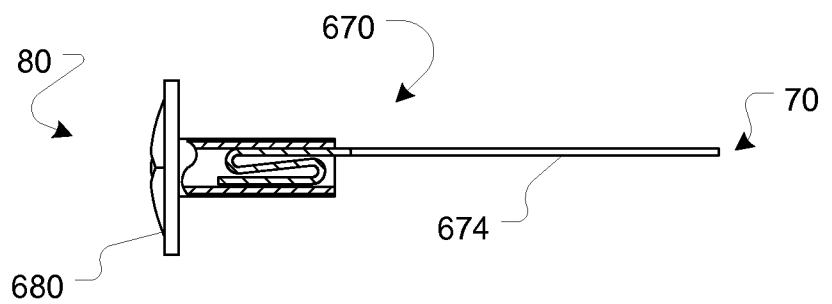
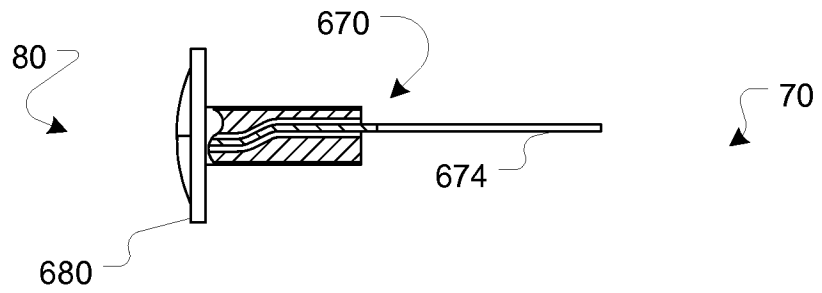
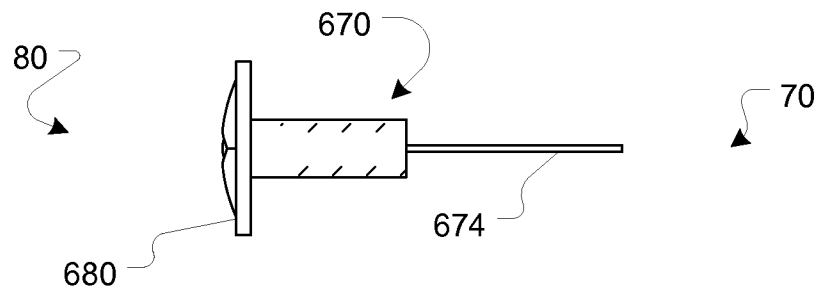
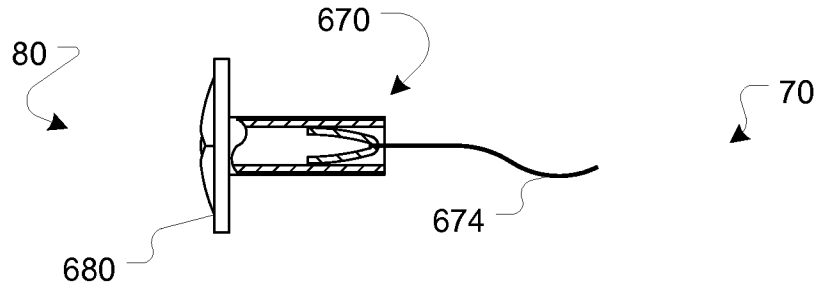

FIG. 81H



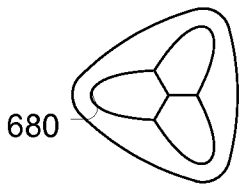

FIG. 81I

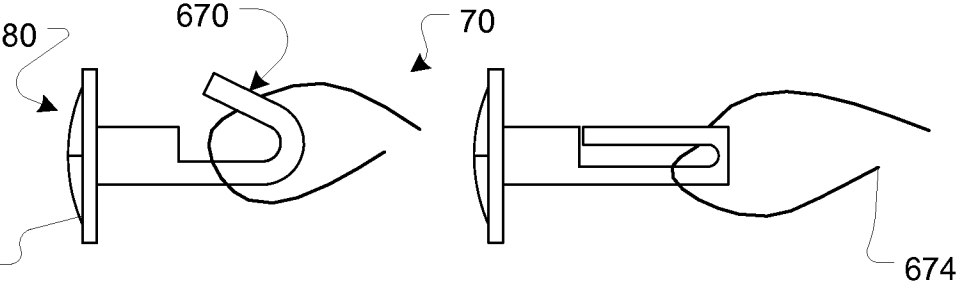
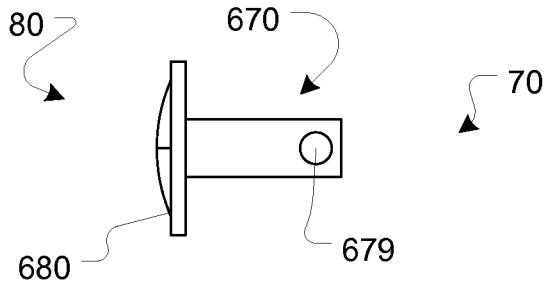

FIG. 81J

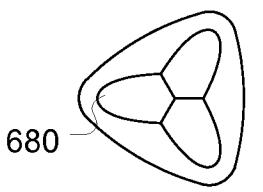

FIG. 81K

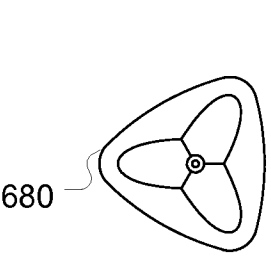
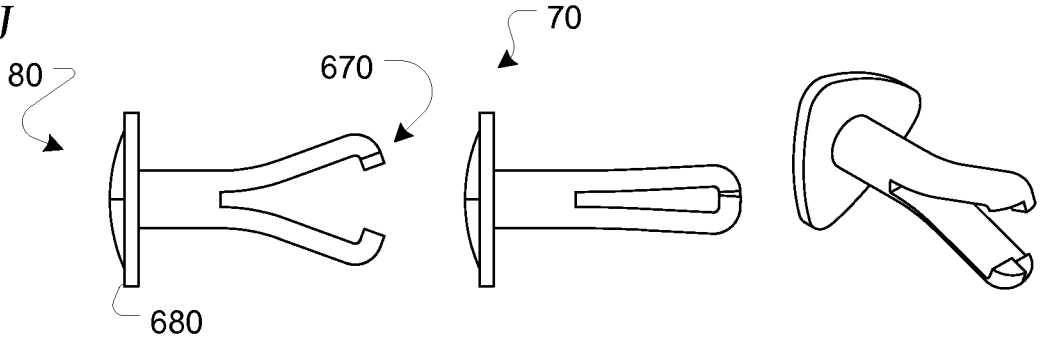

FIG. 81L

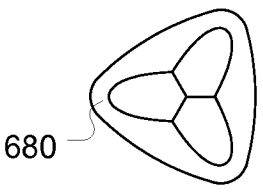
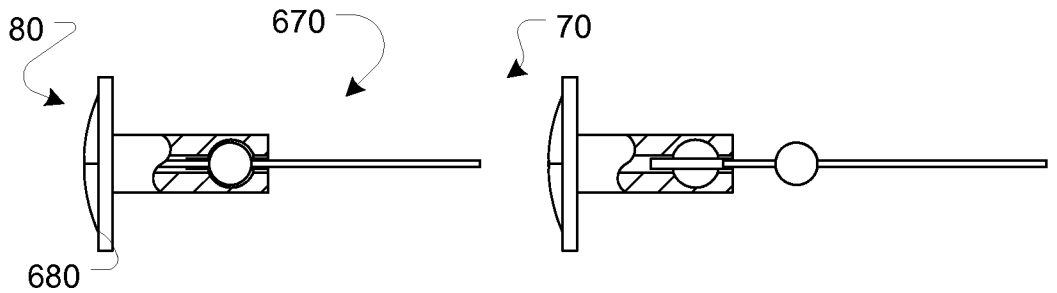
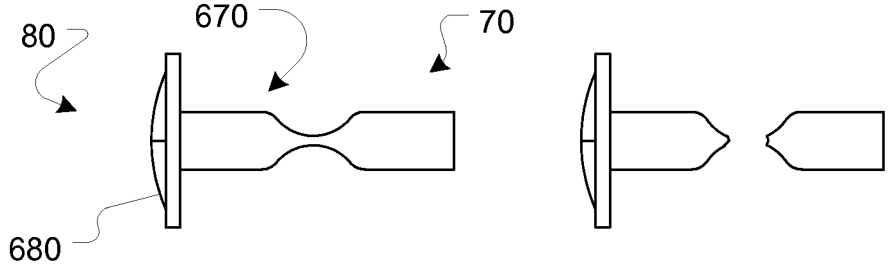

FIG. 81M



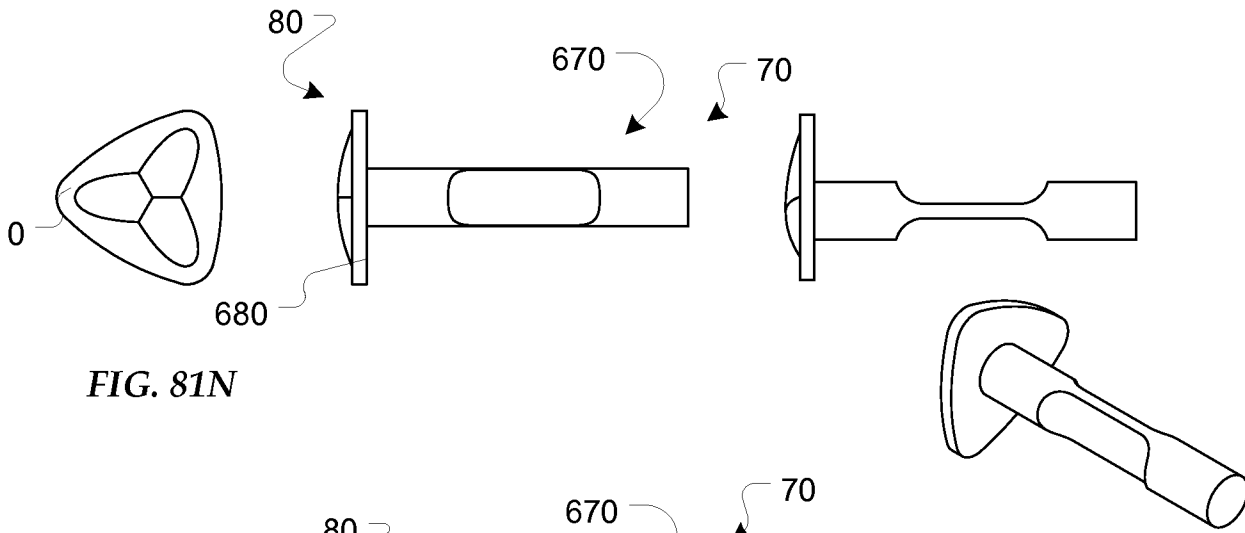

FIG. 81N

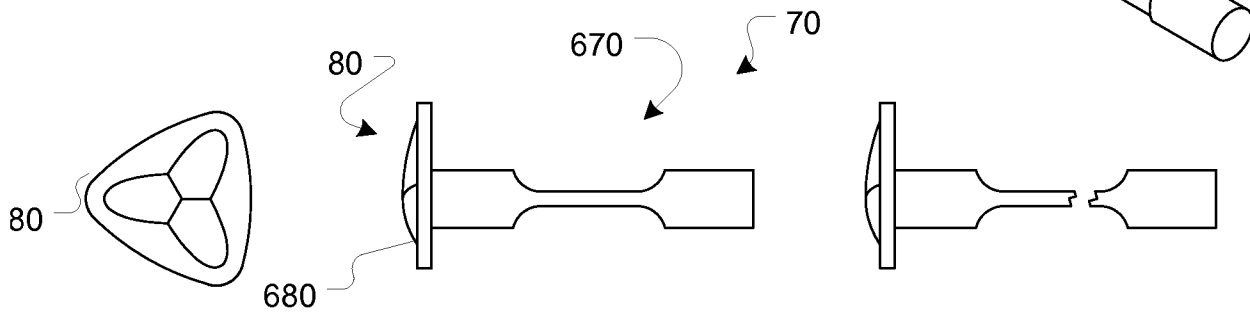

FIG. 82A

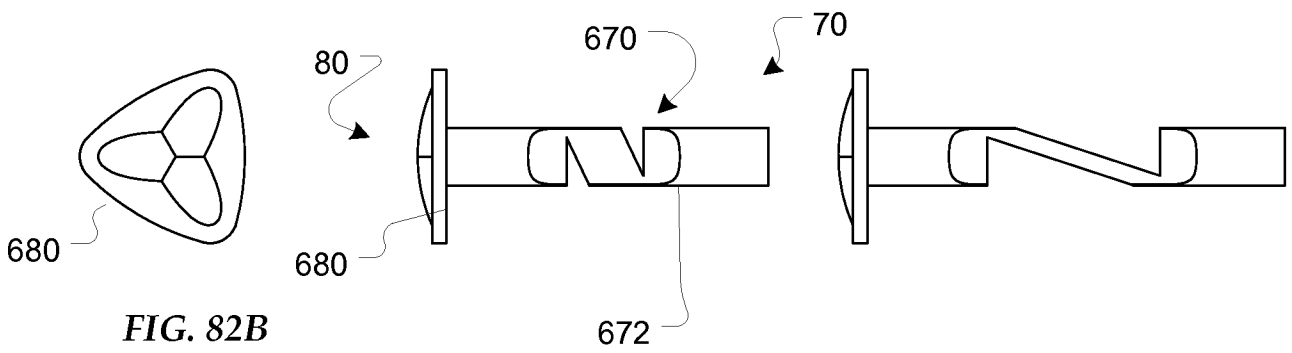

FIG. 82B

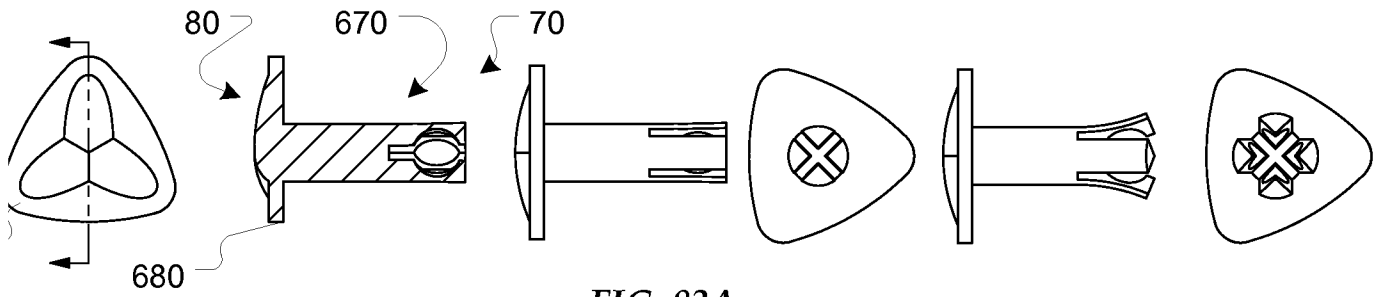

FIG. 83A

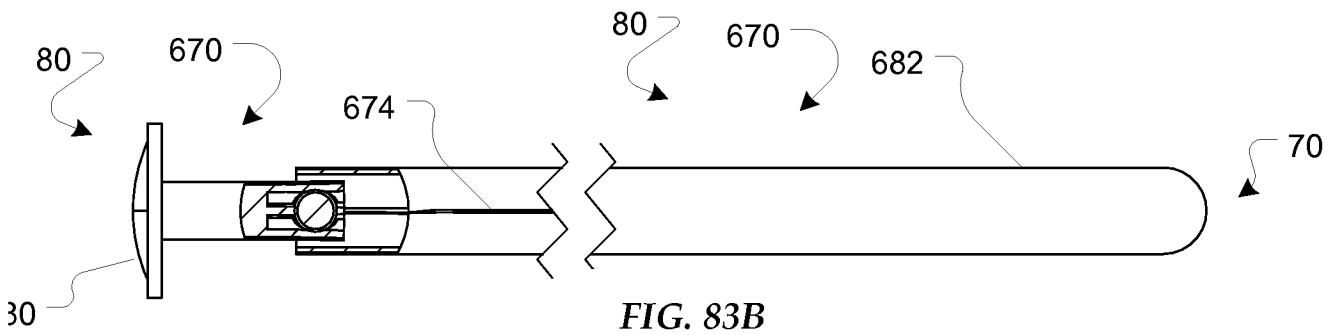

FIG. 83B

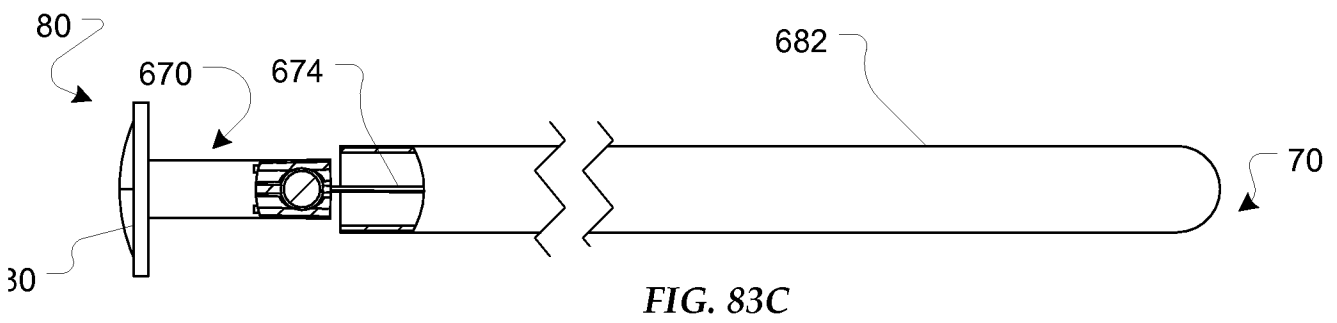

FIG. 83C

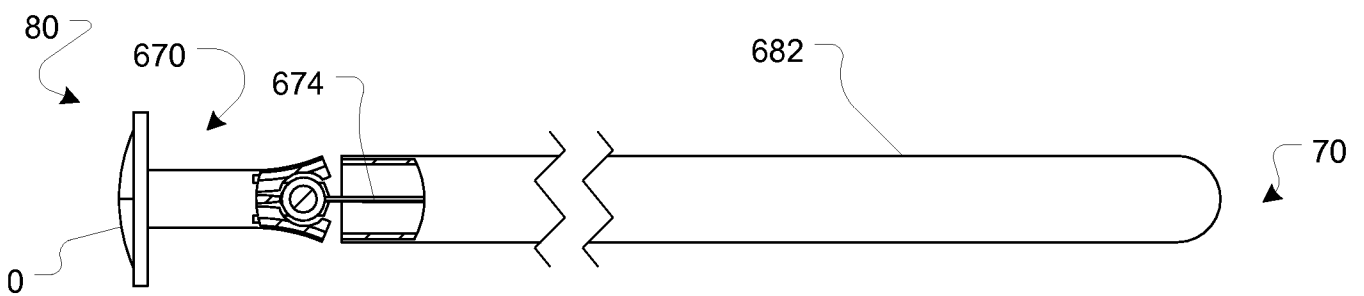
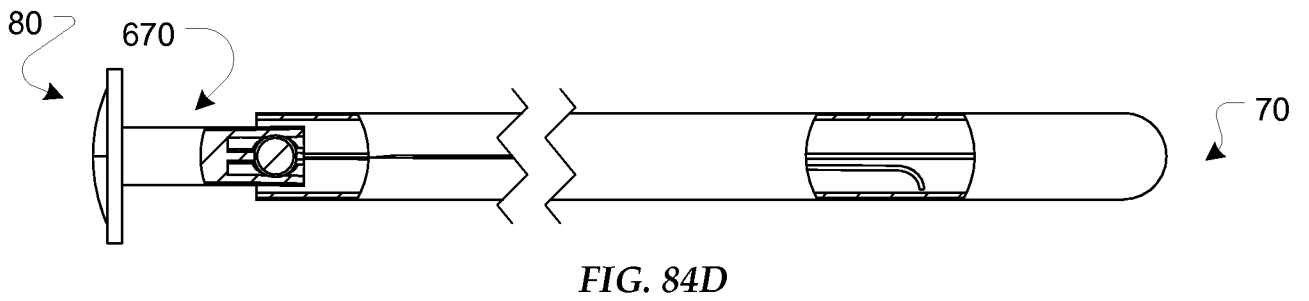
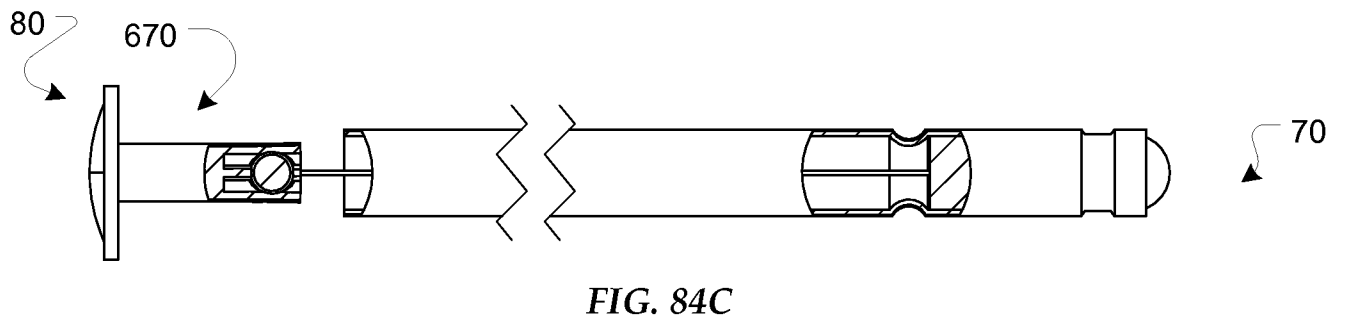
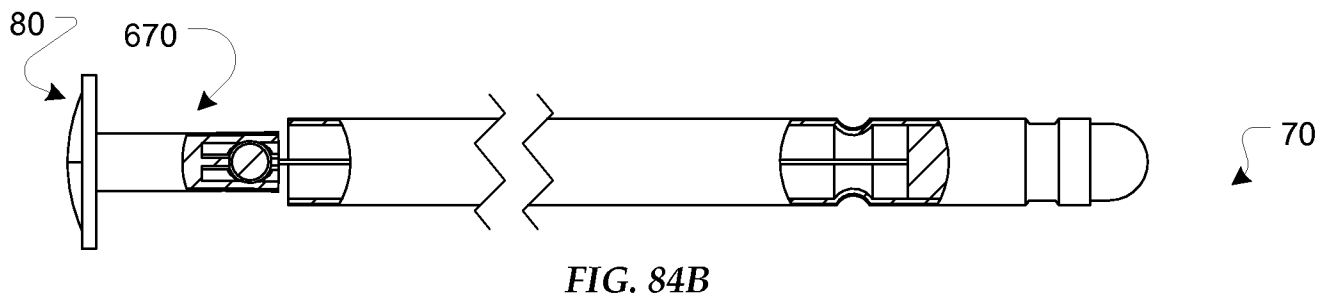
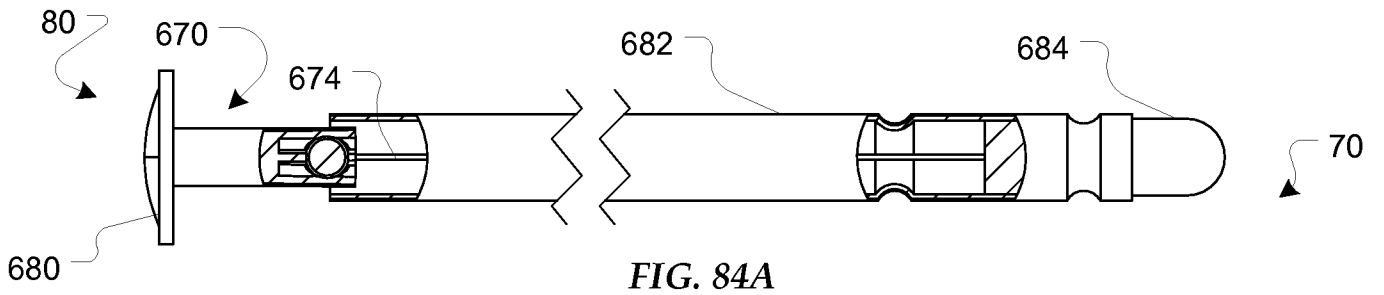

FIG. 83D



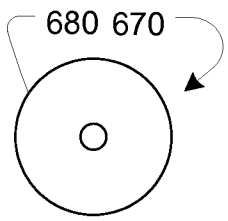

FIG. 85A

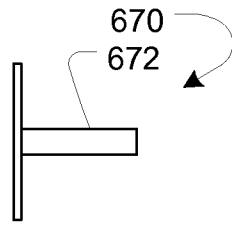

FIG. 85B

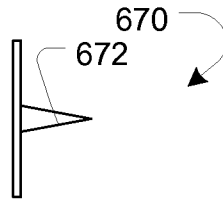

FIG. 85C

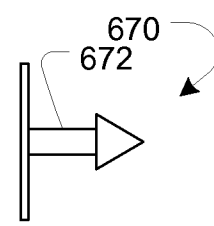

FIG. 85D

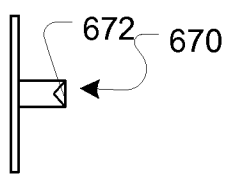

FIG. 85E

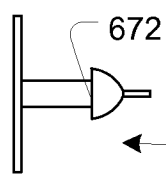

FIG. 85F

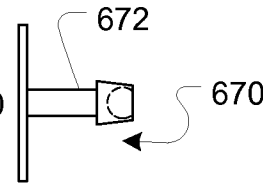

FIG. 85G

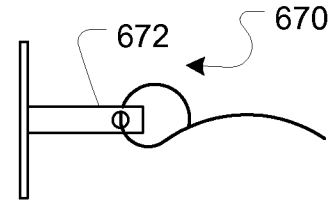

FIG. 85H

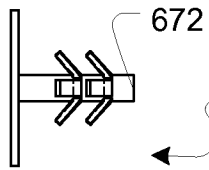

FIG. 85I

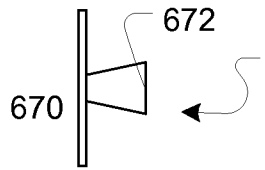

FIG. 85J

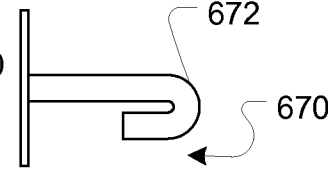

FIG. 85K

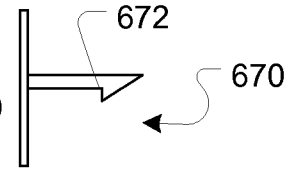

FIG. 85L

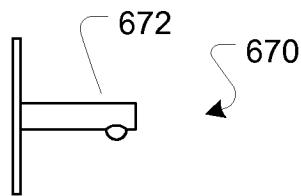

FIG. 85M

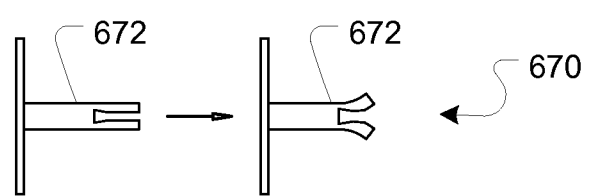

FIG. 85N

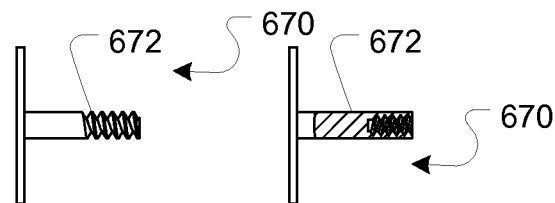

FIG. 85O

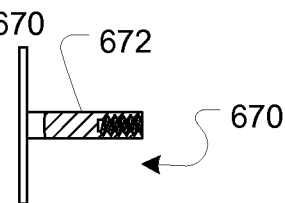

FIG. 85P

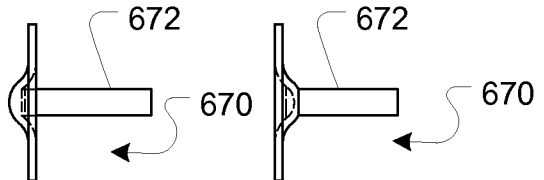

FIG. 85Q

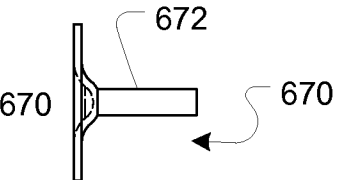

FIG. 85R

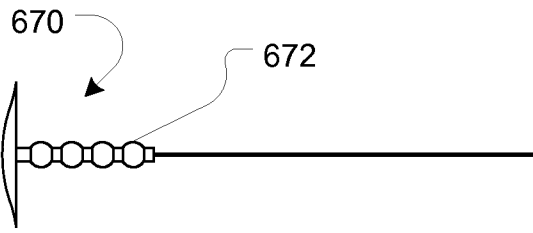

FIG. 86A

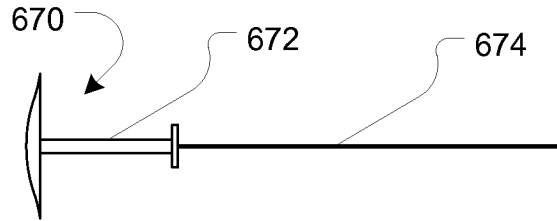

FIG. 86B

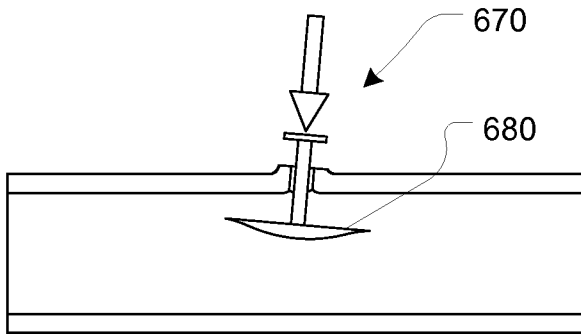

FIG. 86C

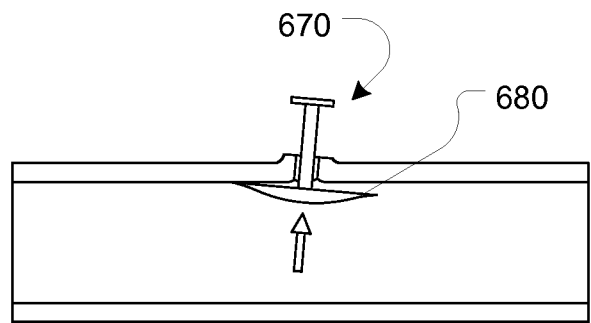

FIG. 86D

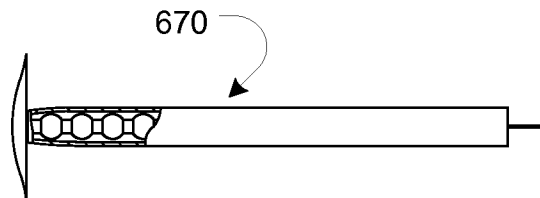

FIG. 86E

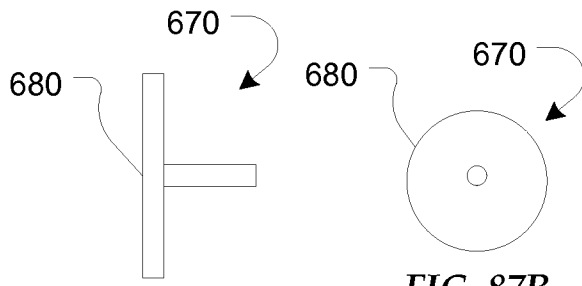

FIG. 87A

FIG. 87B

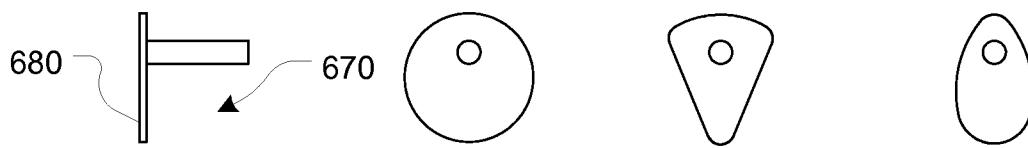

FIG. 88A

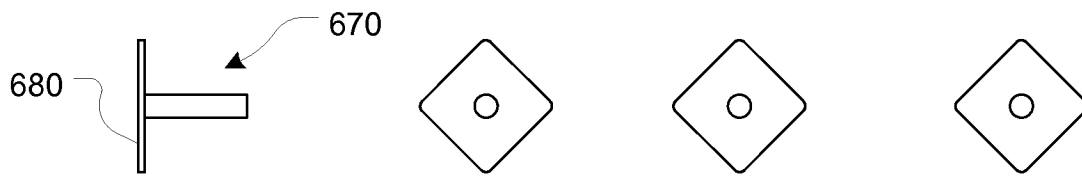

FIG. 88B



FIG. 88C

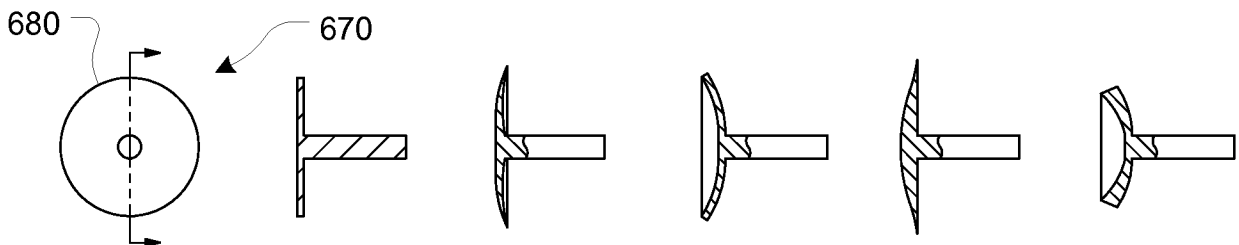

FIG. 88D

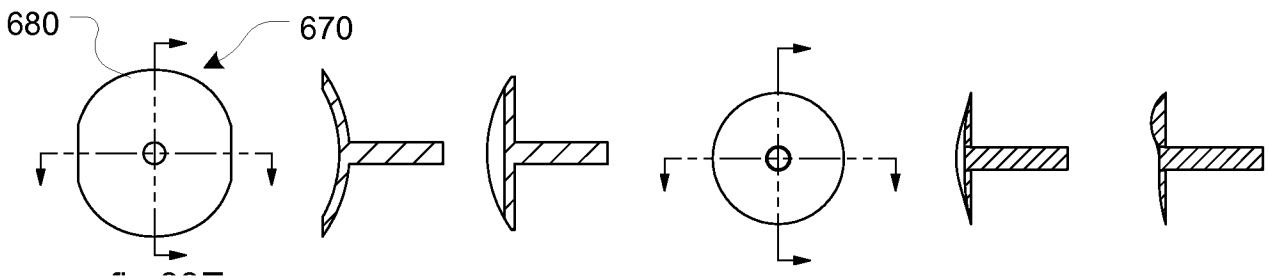

FIG. 88E

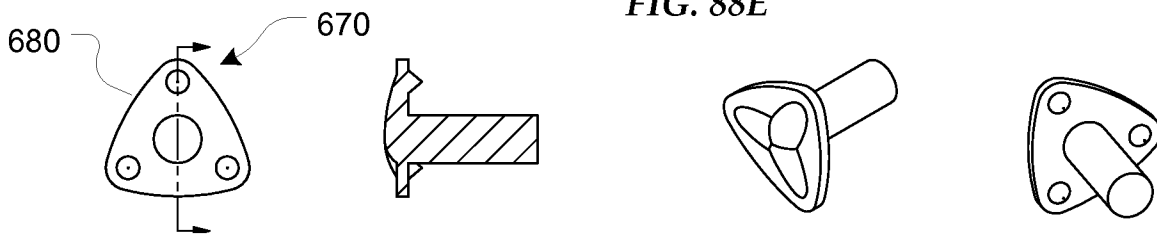

FIG. 88F

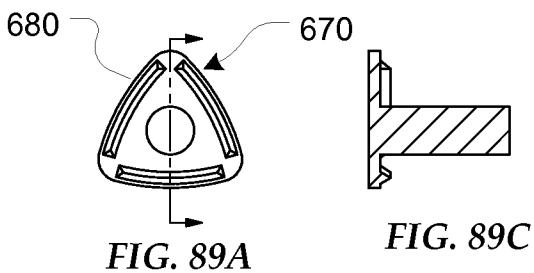

FIG. 89A

FIG. 89C

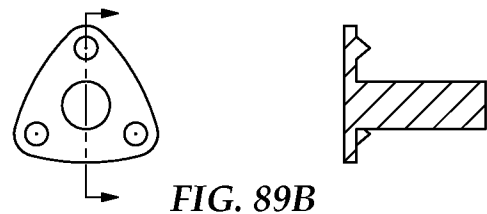

FIG. 89B

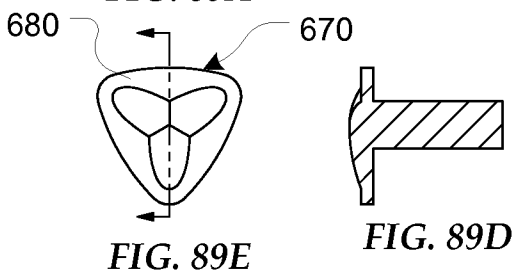

FIG. 89E

FIG. 89D

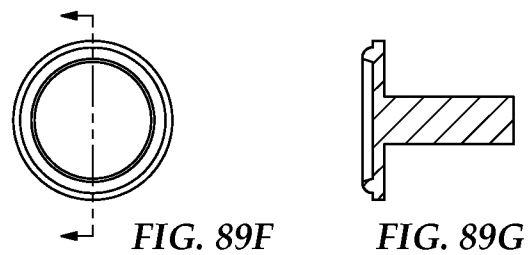

FIG. 89F

FIG. 89G

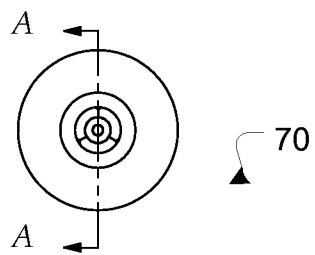

FIG. 90B

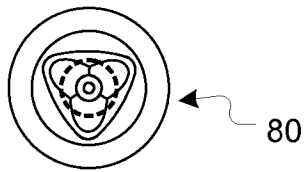

FIG. 90E

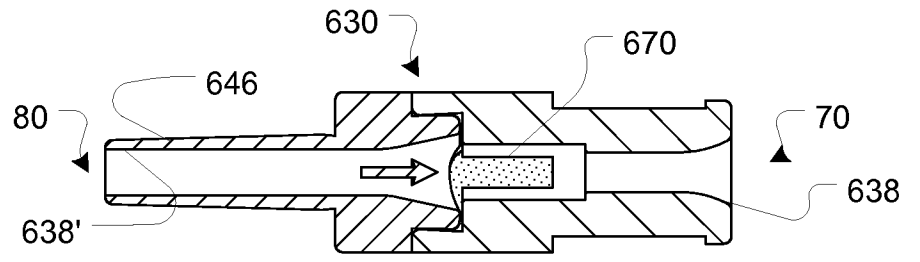

FIG. 90A

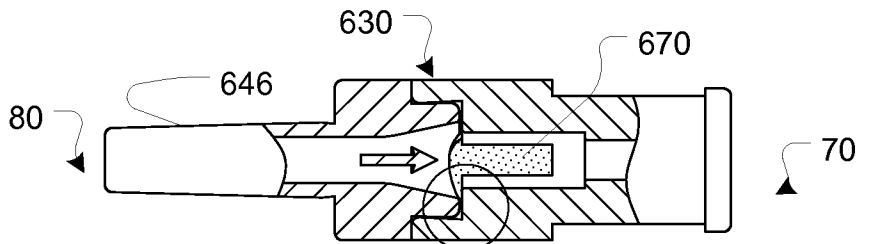

FIG. 90C

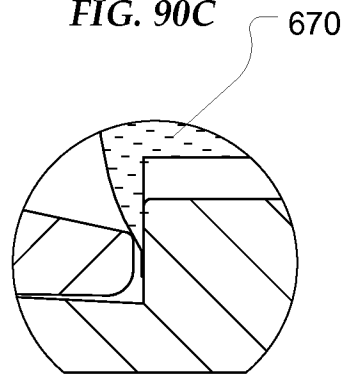

FIG. 90D

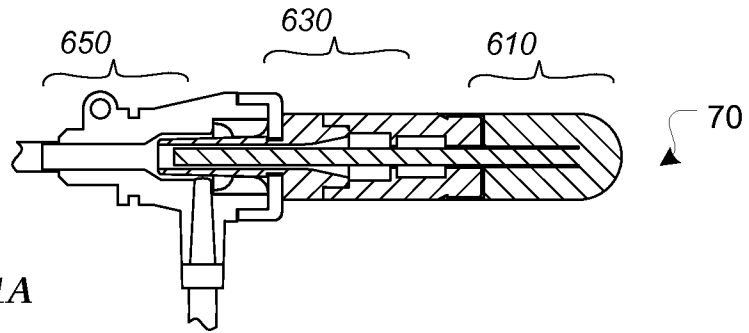

FIG. 91A

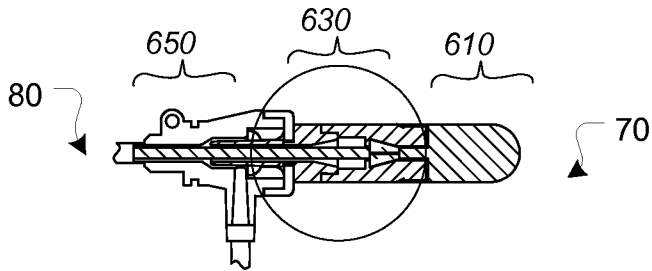

FIG. 91B

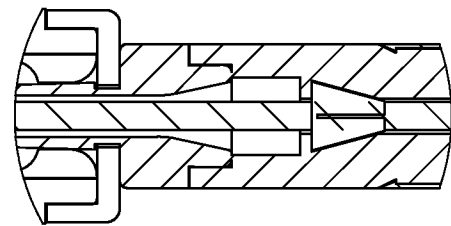

FIG. 91C

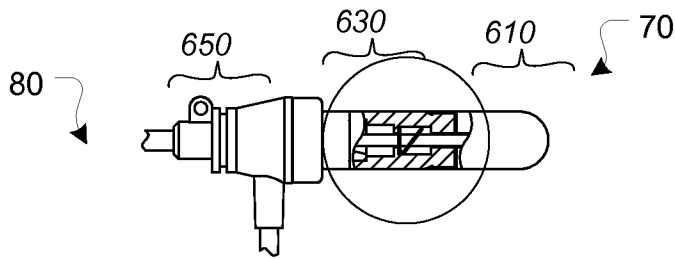

FIG. 91D

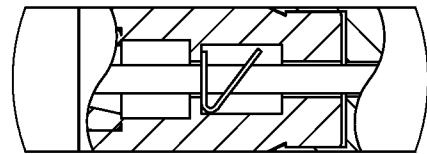

FIG. 91E

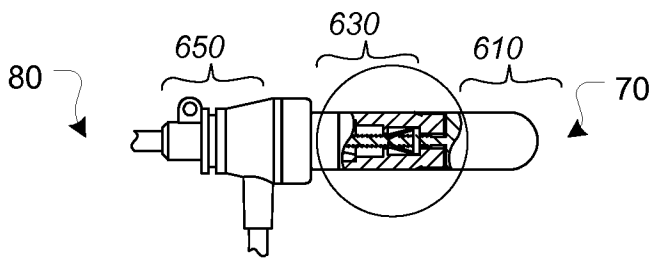

FIG. 91F

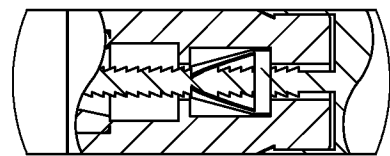

FIG. 91G

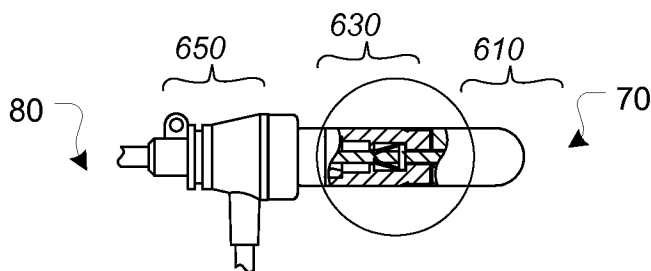

FIG. 91H

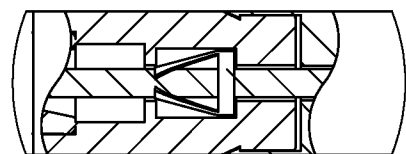

FIG. 91 i

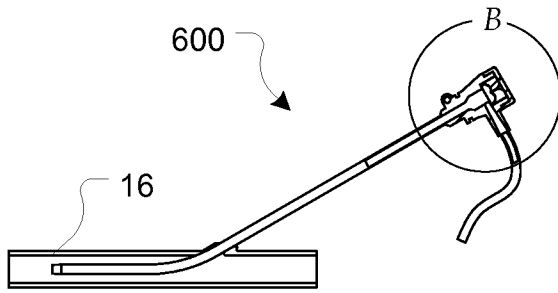

FIG. 92A

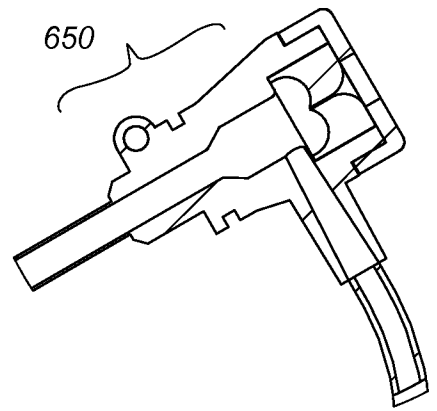

FIG. 92B

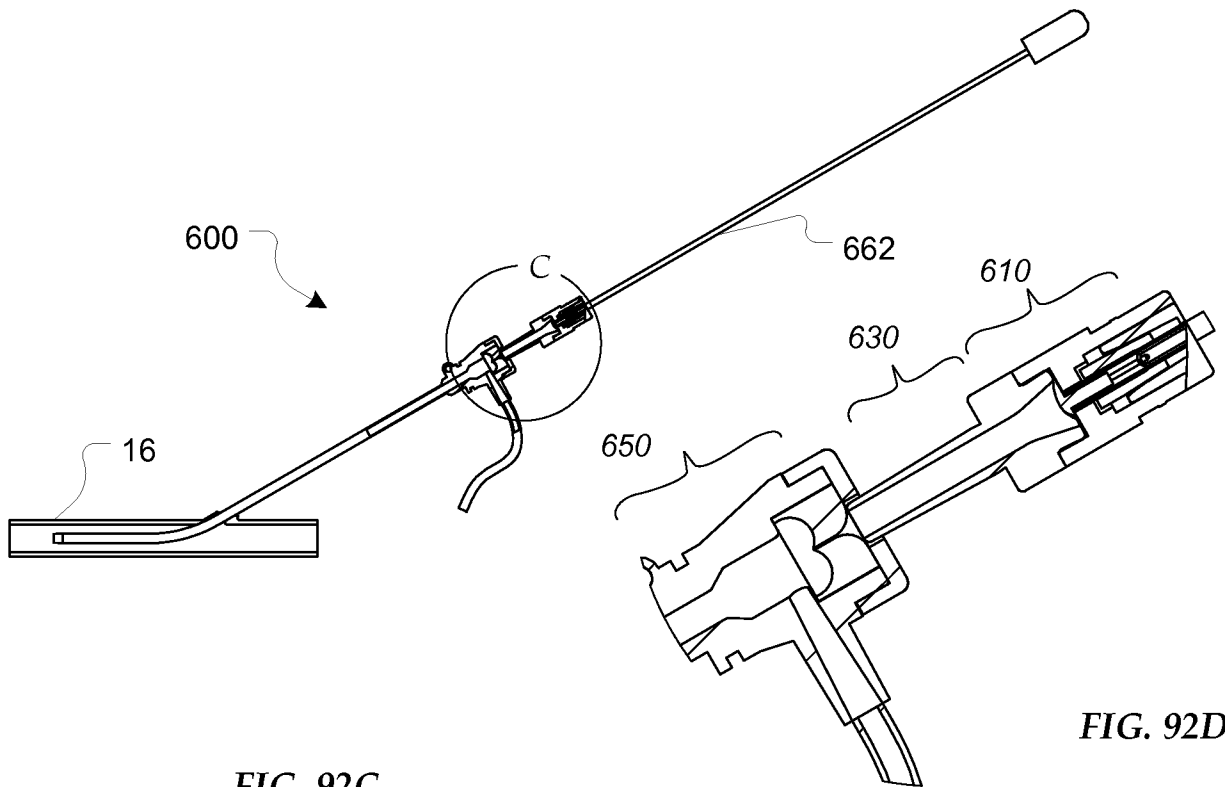

FIG. 92C

FIG. 92D

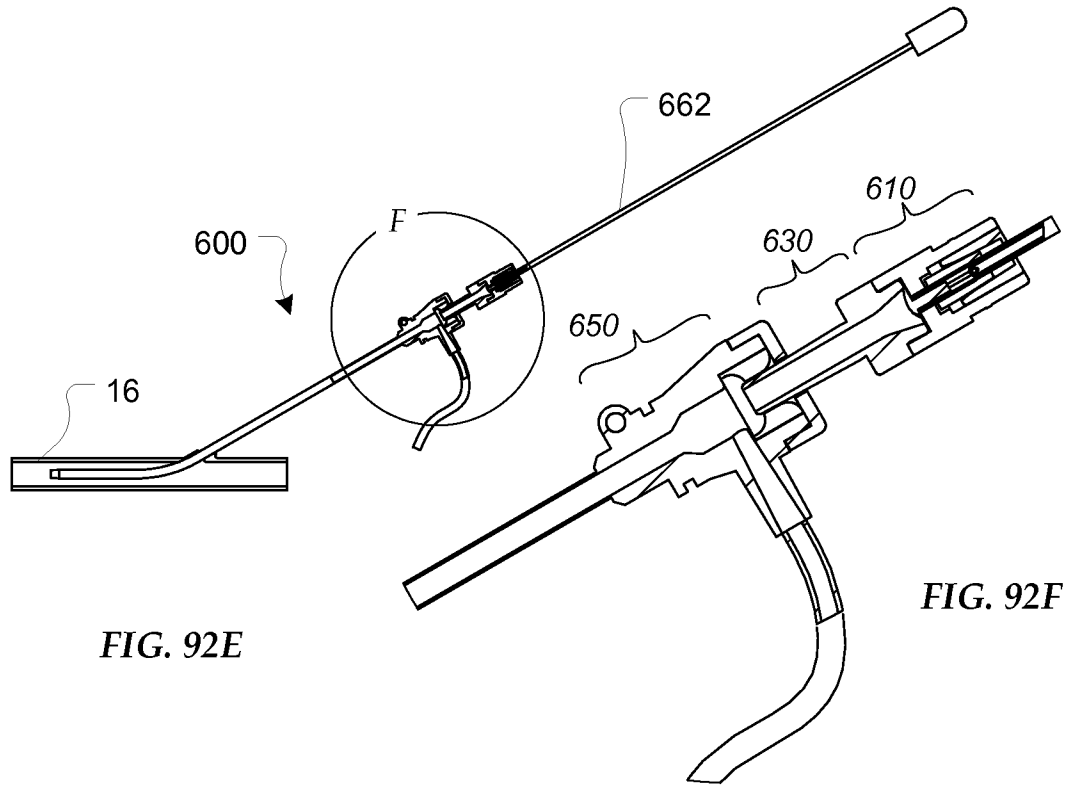

FIG. 92E

FIG. 92F

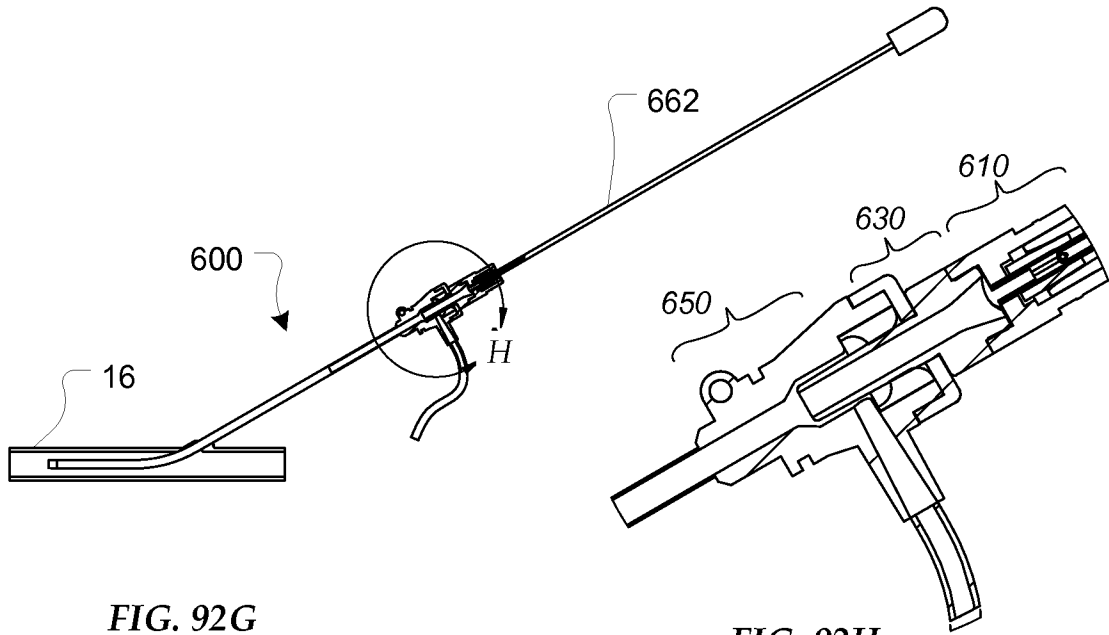

FIG. 92G

FIG. 92H

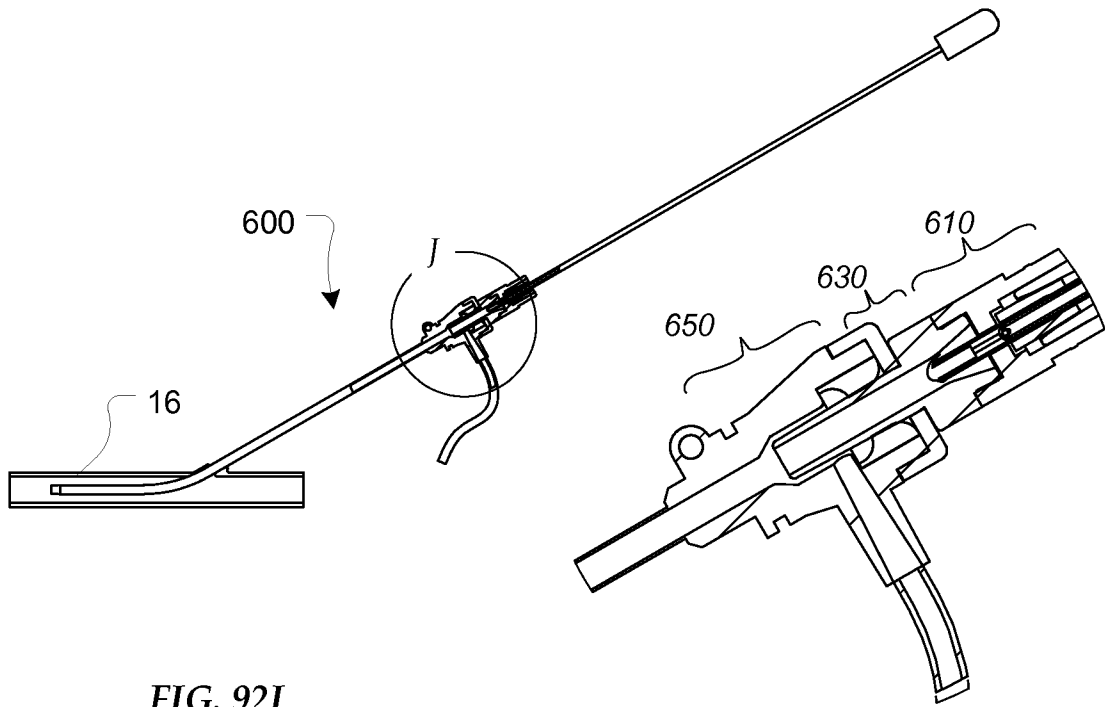

FIG. 92I

FIG. 92J

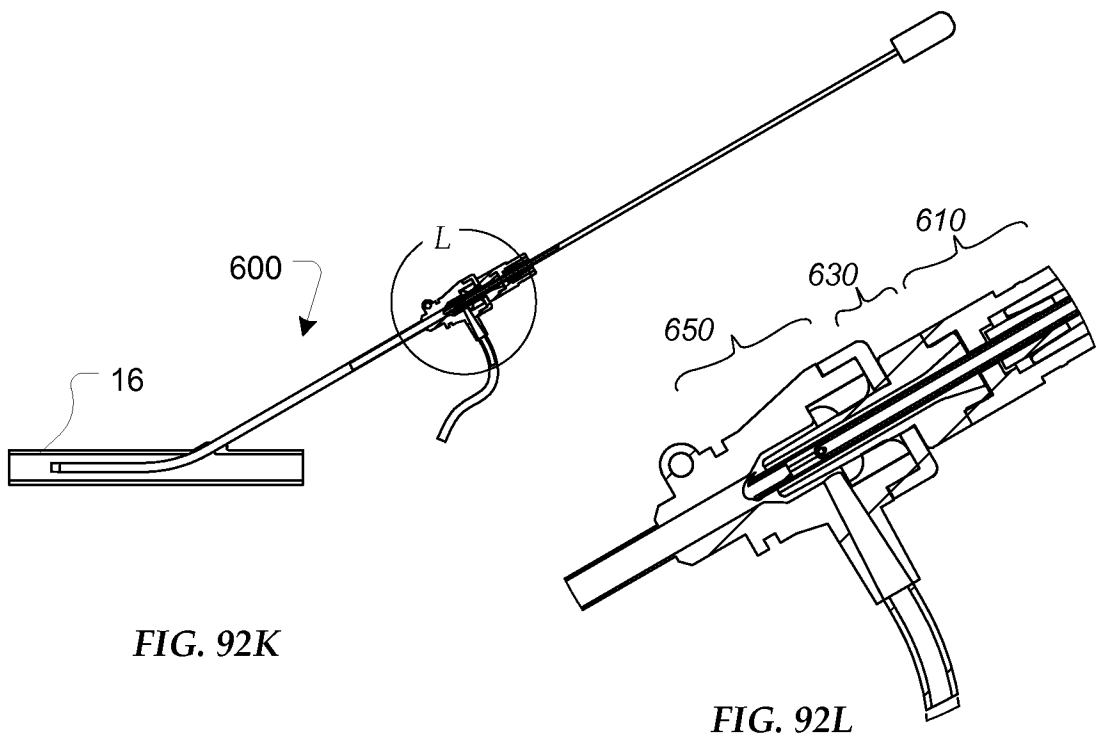

FIG. 92K

FIG. 92L

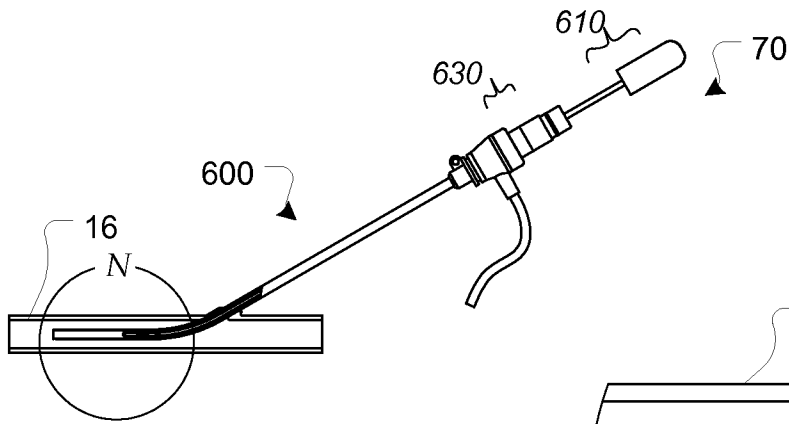

FIG. 92M

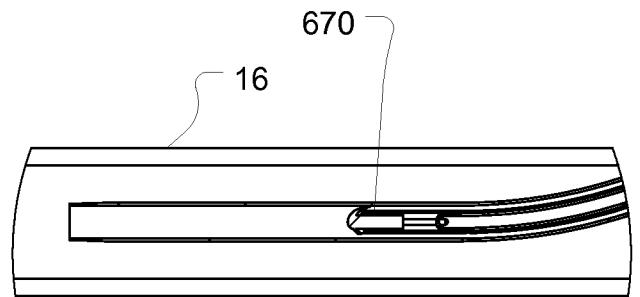

FIG. 92N

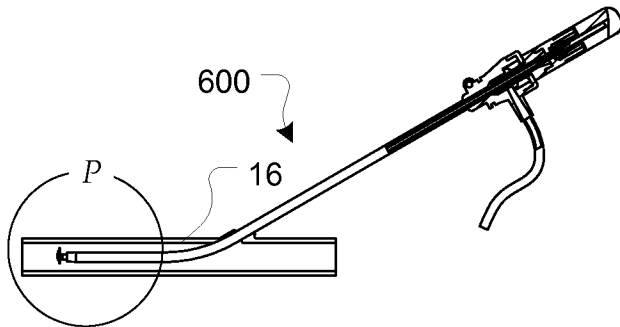

FIG. 92O

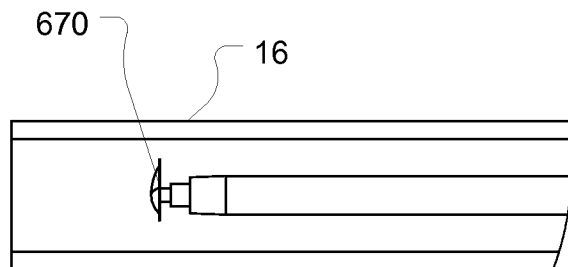

FIG. 92P

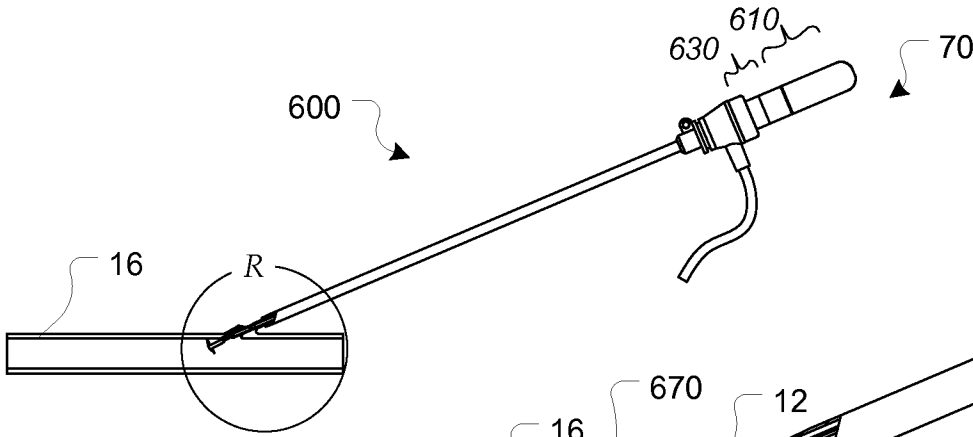

FIG. 92Q

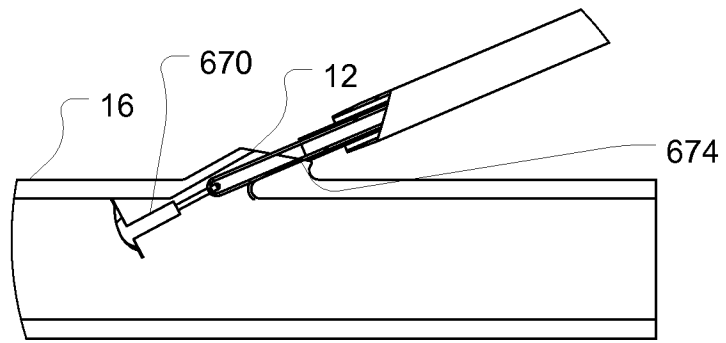

FIG. 92R

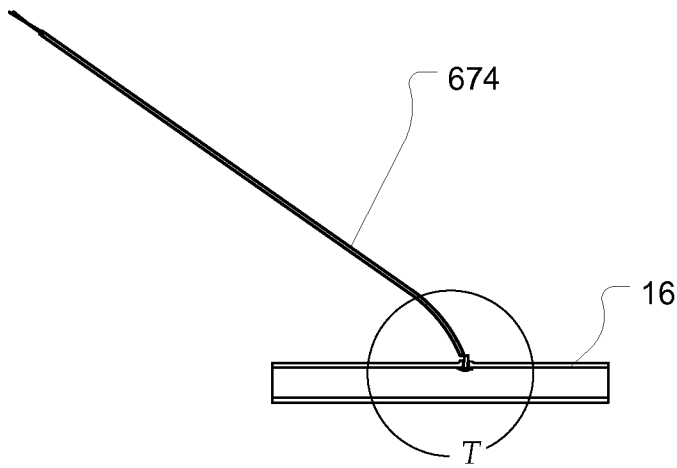

FIG. 92S

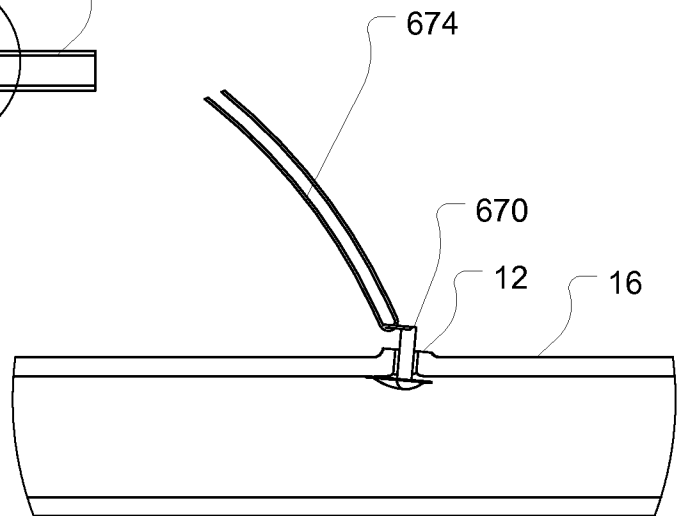
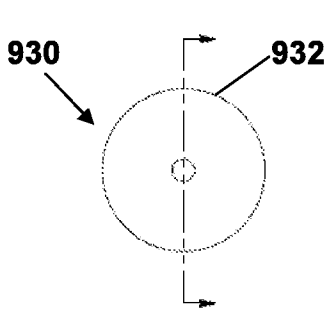
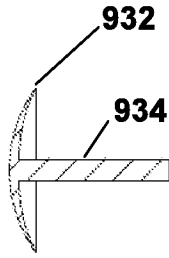

FIG. 92T

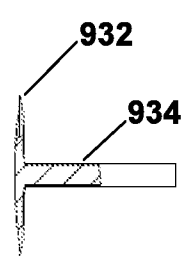

**FIG. 93A**



neutral state

**FIG. 93B**



max strain state

**FIG. 93C**

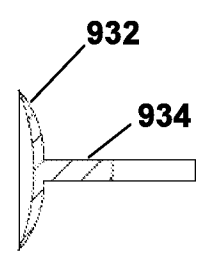

over center state

**FIG. 93D**

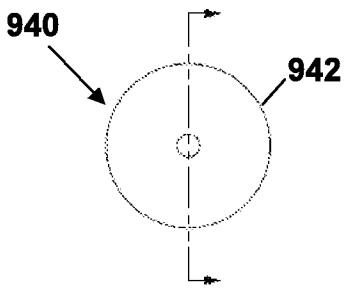

additional figs 1

**FIG. 94A**

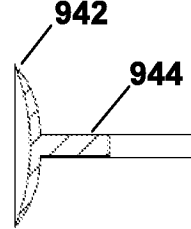

neutral state

**FIG. 94B**

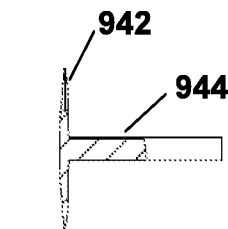

max strain state

**FIG. 94C**

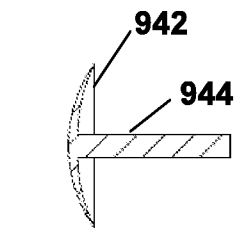

over center state

**FIG. 94D**

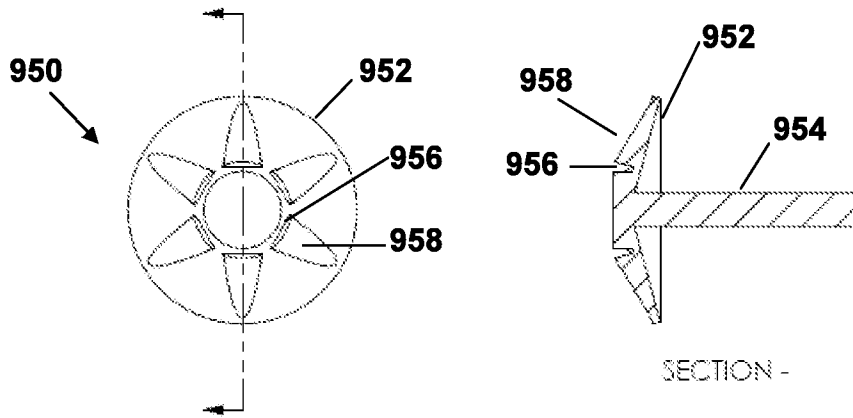

**FIG. 95A**

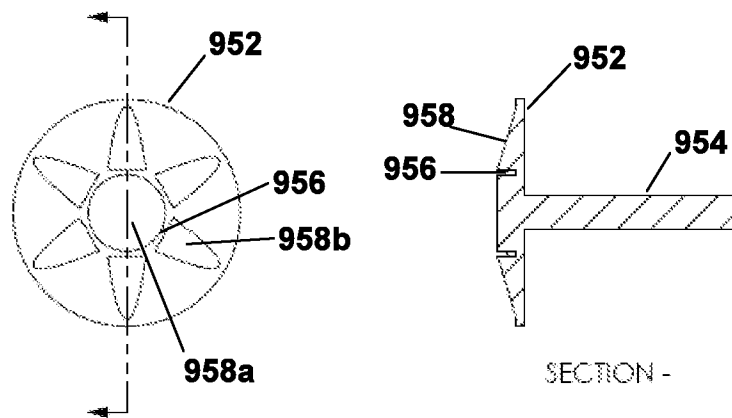

**FIG. 95B**

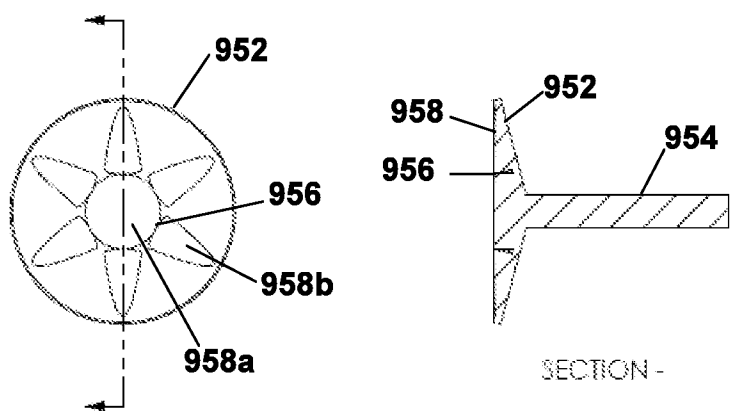

**FIG. 95C**

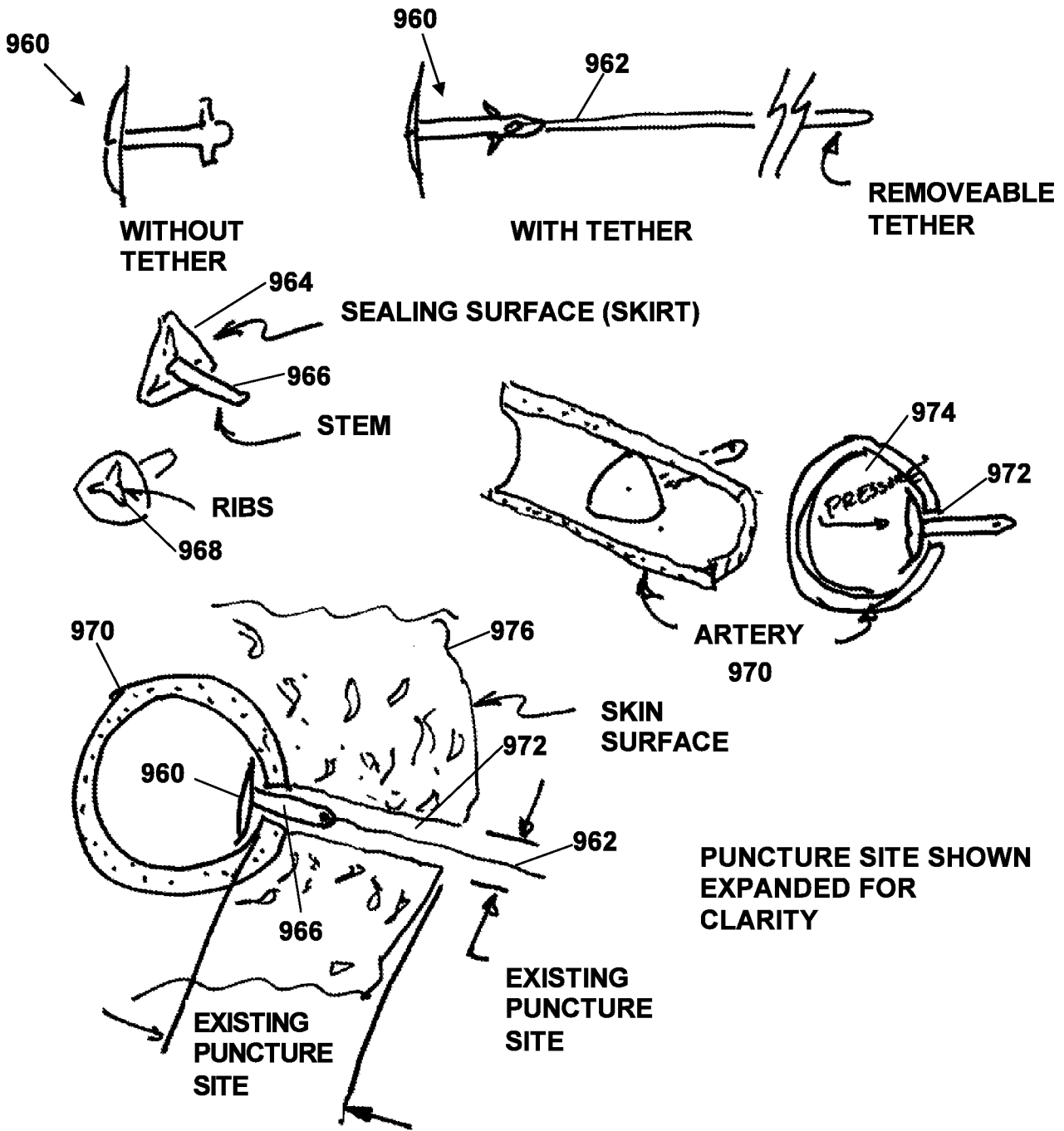

FIG. 96

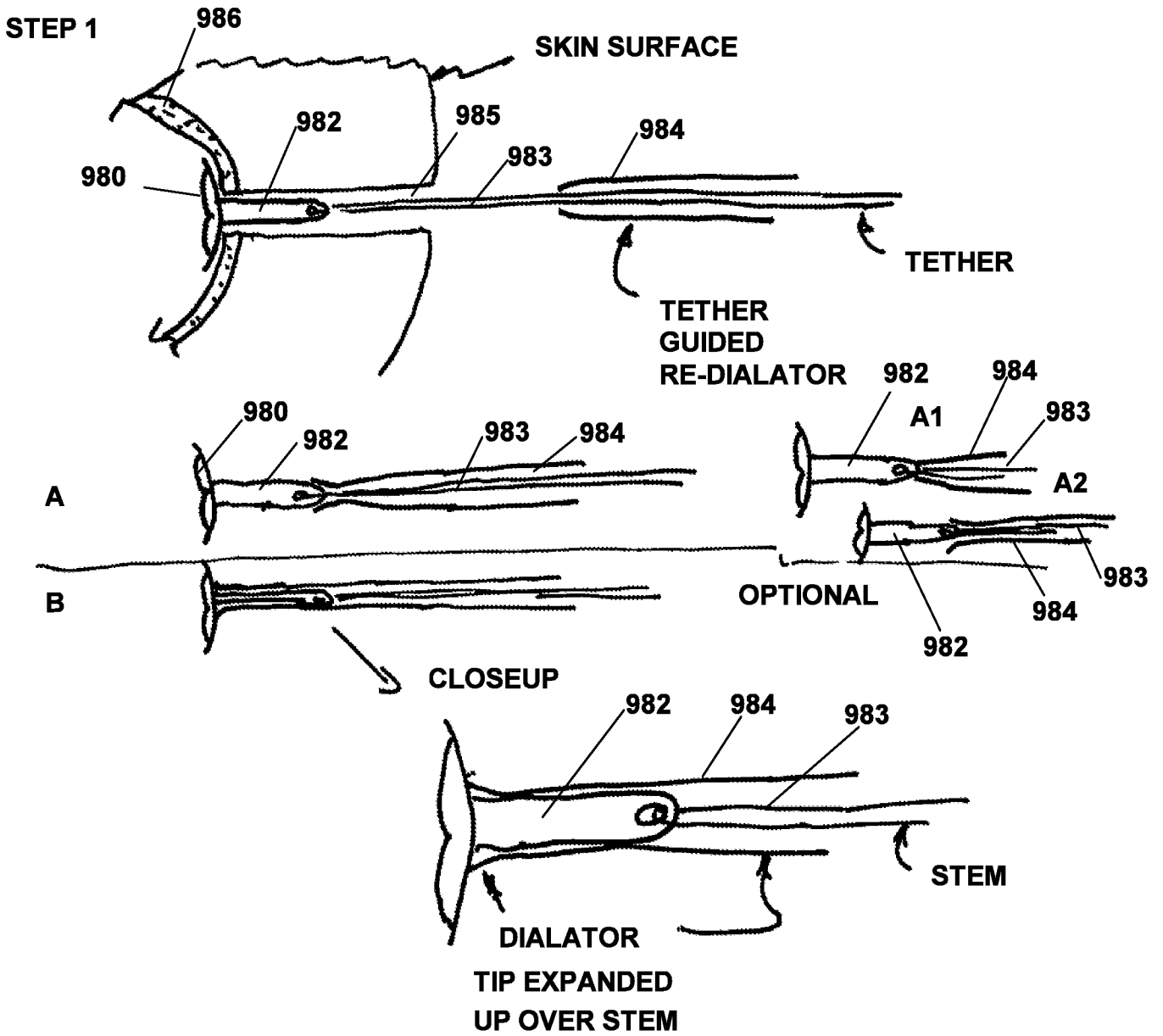

FIG. 97A

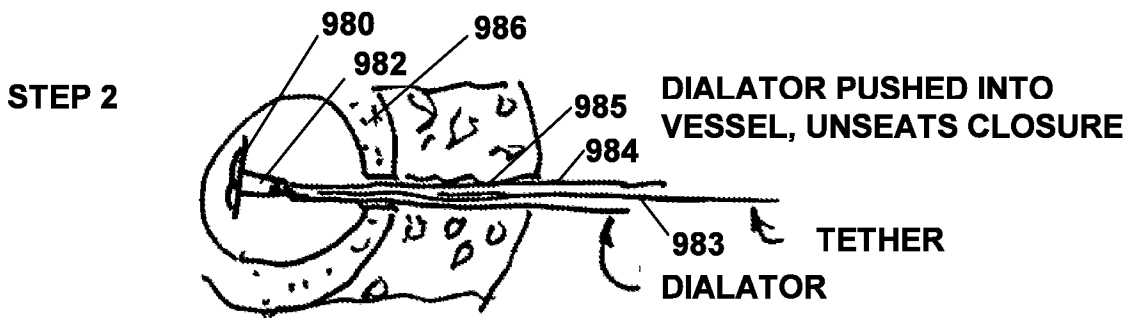

FIG. 97B

STEP 3

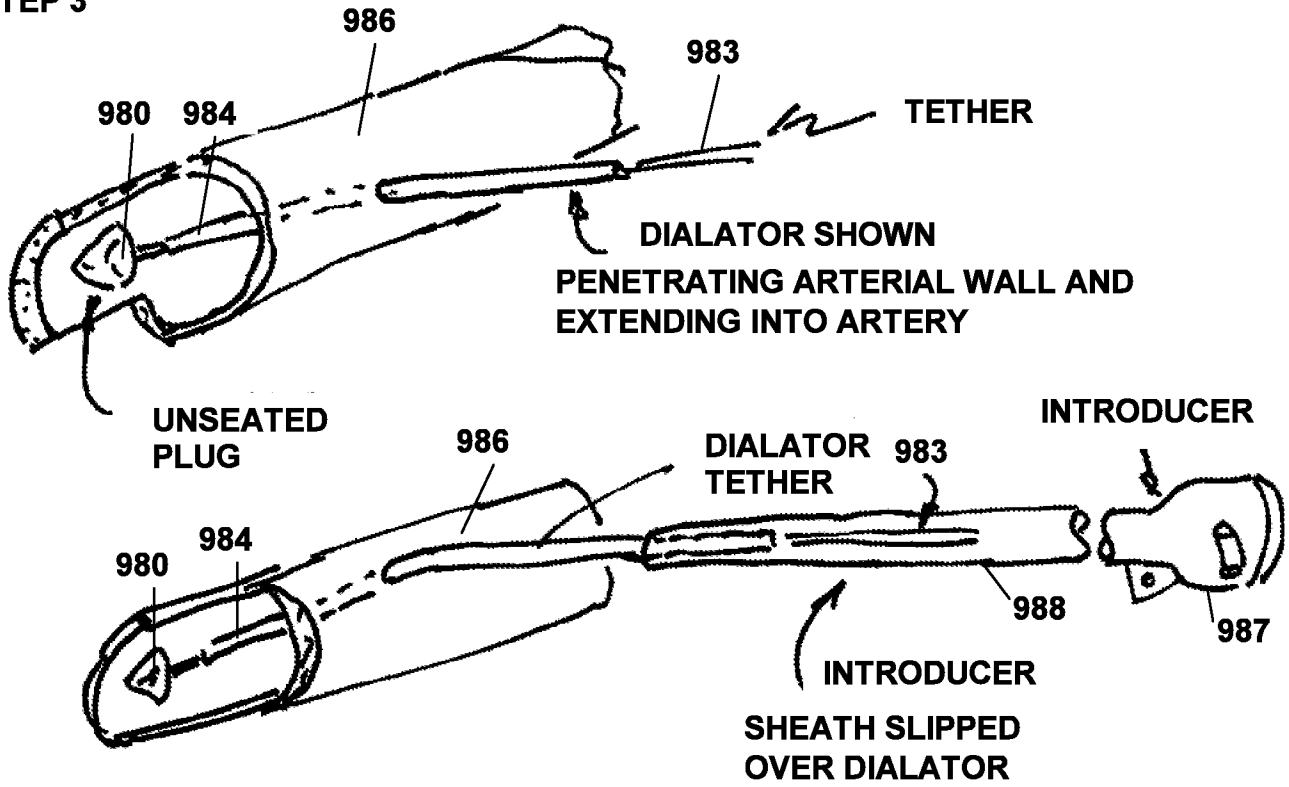
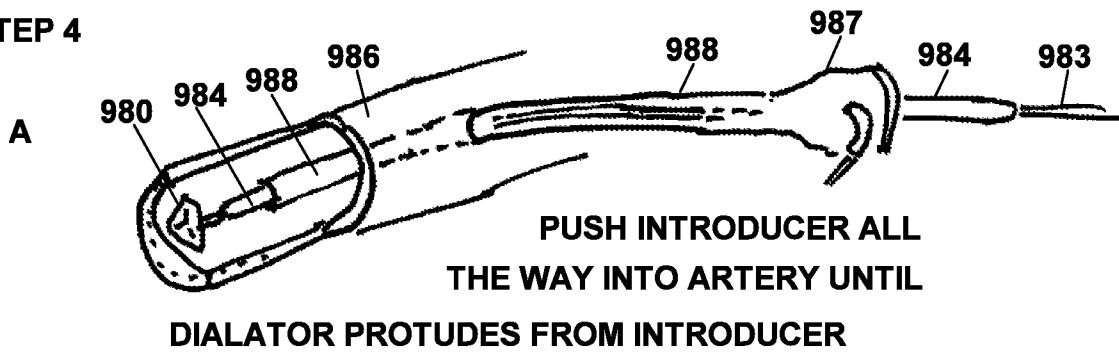
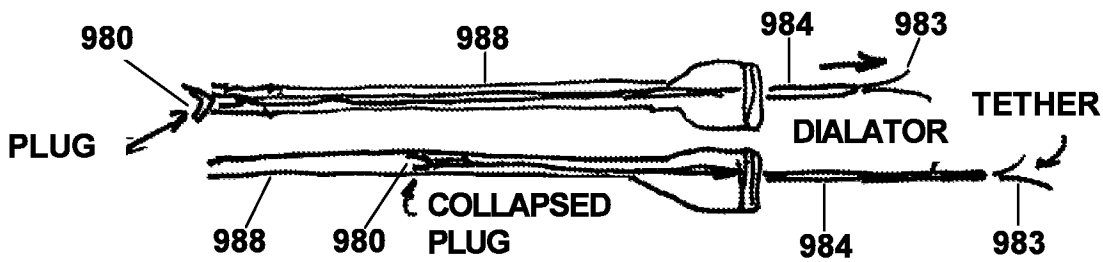

FIG. 97C

**STEP 4**



**B** **FULL ON DIALATOR UNTIL PLUG COLLAPSES ALL THE WAY INTO INTRODUCER TIP, CONTINUE PULLING UNTIL PLUG-TETHER-DIALATOR ARE COMPLETELY EXTRACTED FROM INTRODUCER**



*FIG. 97D*

OPTIONS

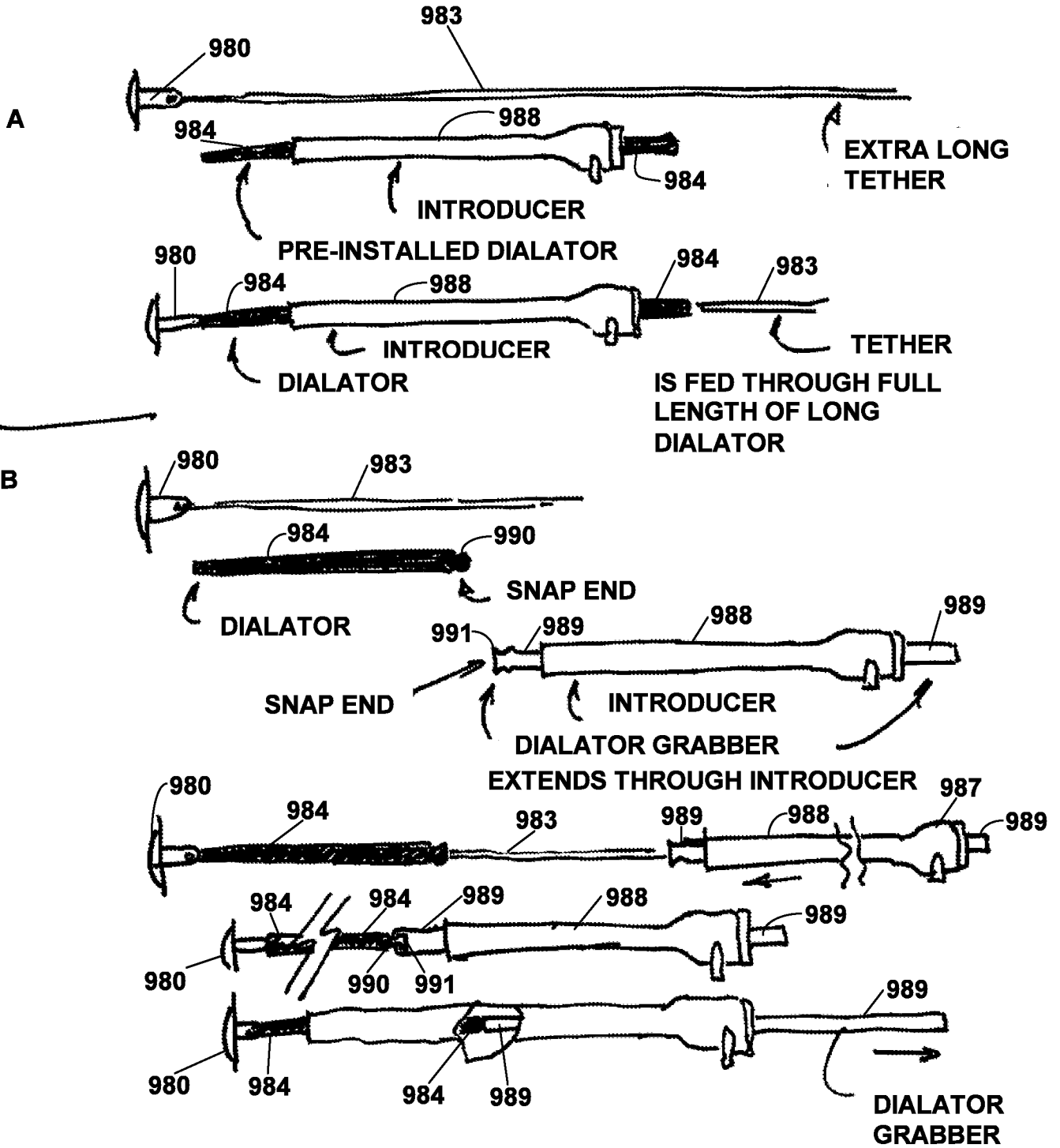

FIG. 97E

专利名称(译)	组织闭合装置，用于递送的装置和系统，试剂盒及其方法		
公开(公告)号	<a href="#">EP2498689A2</a>	公开(公告)日	2012-09-19
申请号	EP2010829294	申请日	2010-11-09
[标]申请(专利权)人(译)	心血管科技股份有限公司		
申请(专利权)人(译)	心血管TECHNOLOGIES, INC.		
当前申请(专利权)人(译)	心血管TECHNOLOGIES, INC.		
[标]发明人	HOUSER RUSSELL A BOWER JOHN HUNTER		
发明人	HOUSER, RUSSELL, A. BOWER, JOHN, HUNTER		
IPC分类号	A61B17/04 A61B17/34 A61M25/01		
CPC分类号	A61B17/0057 A61B17/0644 A61B17/32 A61B17/3209 A61B18/1482 A61B50/30 A61B2017/00477 A61B2017/00615 A61B2017/00623 A61B2017/00659 A61B2017/00668 A61B2017/00672 A61B2017 /0462 A61B2017/0641 A61B2018/00422 A61B2018/00601 A61B2018/00916 A61B2018/1412 A61B2018/1455 A61B2090/036 A61B2090/037		
优先权	12/757275 2010-04-09 US 61/280896 2009-11-09 US		
其他公开文献	EP2498689A4		
外部链接	<a href="#">Espacenet</a>		

#### 摘要(译)

本发明涉及组织闭合装置，用于递送的装置和系统，试剂盒及其方法。组织闭合装置可以实现组织闭合而不是压缩，并且可以构造成可以通过导引器或从身体外部快速展开。