

(19) World Intellectual Property Organization
International Bureau



(43) International Publication Date
12 January 2006 (12.01.2006)

PCT

(10) International Publication Number
WO 2006/004652 A1

(51) International Patent Classification⁷ : **A61B 17/34**

24662 Canela, Mission Viejo, CA 92692 (US). **HILAL, Nabil** [US/US]; 25291 Spindlewood, Laguna Niguel, CA 92677 (US).

(21) International Application Number:
PCT/US2005/022716

(74) Agent: **VU, Kenneth, K.**; 22872 Avenida Empresa, Rancho Santa Margarita, CA 92688 (US).

(22) International Filing Date: 28 June 2005 (28.06.2005)

(25) Filing Language: English

(81) Designated States (unless otherwise indicated, for every kind of national protection available): AE, AG, AL, AM, AT, AU, AZ, BA, BB, BG, BR, BW, BY, BZ, CA, CH, CN, CO, CR, CU, CZ, DE, DK, DM, DZ, EC, EE, EG, ES, FI, GB, GD, GE, GH, GM, HR, HU, ID, IL, IN, IS, JP, KE, KG, KM, KP, KR, KZ, LC, LK, LR, LS, LT, LU, LV, MA, MD, MG, MK, MN, MW, MX, MZ, NA, NG, NI, NO, NZ, OM, PG, PH, PL, PT, RO, RU, SC, SD, SE, SG, SK, SL, SM, SY, TJ, TM, TN, TR, TT, TZ, UA, UG, US, UZ, VC, VN, YU, ZA, ZM, ZW.

(26) Publication Language: English

(30) Priority Data:
60/584,302 29 June 2004 (29.06.2004) US
10/956,167 1 October 2004 (01.10.2004) US

(71) Applicant (for all designated States except US): **APPLIED MEDICAL RESOURCES CORPORATION** [US/US]; 22872 Avenida Empresa, Rancho Santa Margarita, CA 92688 (US).

(72) Inventors; and

(75) Inventors/Applicants (for US only): **ALBRECHT, Jeremy, J.** [US/US]; 27082 O'Neill Drive, #220, Ladera Ranch, CA 92694 (US). **BRUSTAD, John, R.** [US/US]; 34056 Formosa Drive, Dana Point, CA 92629 (US). **TAYLOR, Scott, V.** [US/US]; 27851 Encanto, Mission Viejo, CA 92692 (US). **JOHNSON, Gary, M.** [US/US];

(84) Designated States (unless otherwise indicated, for every kind of regional protection available): ARIPO (BW, GH, GM, KE, LS, MW, MZ, NA, SD, SL, SZ, TZ, UG, ZM, ZW), Eurasian (AM, AZ, BY, KG, KZ, MD, RU, TJ, TM), European (AT, BE, BG, CH, CY, CZ, DE, DK, EE, ES, FI, FR, GB, GR, HU, IE, IS, IT, LT, LU, MC, NL, PL, PT, RO, SE, SI, SK, TR), OAPI (BF, BJ, CF, CG, CI, CM, GA, GN, GQ, GW, ML, MR, NE, SN, TD, TG).

[Continued on next page]

(54) Title: INSUFFLATING OPTICAL SURGICAL INSTRUMENT

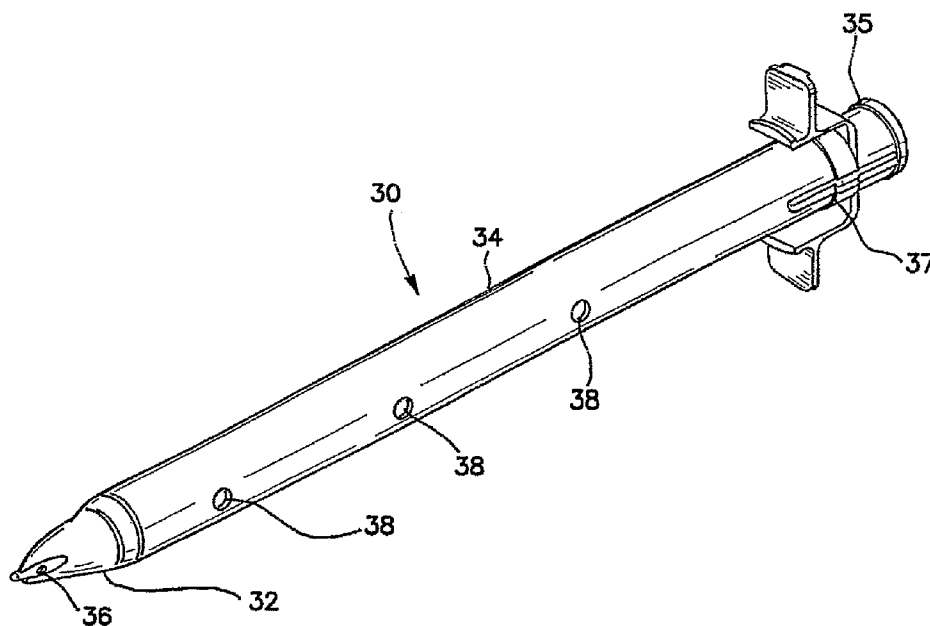

(57) Abstract: An insufflating surgical instrument adapted for movement across an abdominal wall to insufflate an abdominal region of a patient. The instrument comprises a shaft having an insufflation extending along an axis between a proximal end and a distal end, the insufflation channel being adapted for connection to a source of fluid under pressure at the proximal end, a tip at the distal end of the shaft, and at least one vent hole formed at the tip or the shaft being in connection with the insufflation channel and being adapted to expel the fluid under pressure to insufflate the abdominal region. At least one of the tip and the shaft is formed of a translucent or transparent material such as polycarbonate to facilitate visualization of the abdominal wall and the abdominal region.

WO 2006/004652 A1



Published:

- with international search report
- before the expiration of the time limit for amending the claims and to be republished in the event of receipt of amendments

For two-letter codes and other abbreviations, refer to the "Guidance Notes on Codes and Abbreviations" appearing at the beginning of each regular issue of the PCT Gazette.

INSUFFLATING OPTICAL SURGICAL INSTRUMENT

This is a non-provisional application claiming the priority of provisional application Serial No. 60/584,302, filed on June 29, 2004, entitled "Insufflating Optical Surgical Instrument," which is fully incorporated herein by reference. This non-provisional
5 application is also filed as a continuation-in-part application claiming the priority of patent application Serial No. 10/956,167, filed on October 1, 2004, entitled "Bladeless Optical Obturator," which is fully incorporated herein by reference.

BACKGROUND OF THE INVENTION

10 Field of the Invention

This invention generally relates to surgical instruments and, in particular, to surgical instruments providing visual entry and visual insufflation.

Discussion of the Prior Art

Laparoscopic surgery of the abdominal area typically requires the introduction of
15 an insufflation gas into the peritoneal cavity of the patient. The insufflation gas is usually pressurized to about 10 mm Hg above atmospheric pressure. This in turn lifts the abdominal wall away from the organs underlying it. Cannulas having seals are then placed at various locations through the abdominal wall to allow the use of a laparoscope and operating instruments. It is well known that establishing access to a non-inflated
20 peritoneal cavity can be a very dangerous part of any laparoscopic procedure. The most common method to achieve insufflation is to pass a sharp needle through the abdominal wall and into the abdominal region, and then inject a gas through the needle

and into the region thereby creating an enlarged or ballooned cavity to accommodate a laparoscopic procedure. Unfortunately, insertion of the needle has been required without any visual aid to facilitate location of the sharp needlepoint. In order to reduce the probability of inadvertent penetration of delicate internal organs in this “blind”
5 procedure, the sharp insufflation needle has been provided with a spring-loaded and retractable safety mechanism.

The safety mechanisms associated with most insufflation needles consist of a blunt or rounded member disposed within the lumen of the needle, and biased by a spring to an extended position beyond the needle tip. This spring must be responsive to
10 the insertion pressure during placement of the needle but must be capable of immediately moving forward when that pressure is relieved. This is a highly mechanical event at best and offers less than optimal arrangement. As pointed out above, a drawback of this procedure is it is performed blindly. A consequence of this blind insertion is the surgeon may inadvertently damage the organs and tissues underlying
15 the abdominal wall such as major blood vessels and the intestinal tract. Once access is gained, it can take several minutes for the gas to insufflate the abdomen and while this is happening the surgeon may be unaware of any complications caused by the insertion of the needle.

Another commonly used method of gaining initial access to the peritoneal cavity
20 is by using a procedure known as the Hasson technique. This method involves making a mini-laparotomy and using the fingers to bluntly dissect the tissues of the abdominal wall and thereby creating an access similar to an open surgical procedure. This method is generally considered to be safer but not without risks, and results in an access site

that is not well suited for the subsequent introduction and use of a laparoscopic cannula. The cannula is typically held in place with an additional device that allows the cannula to be tied down with sutures to prevent it from slipping out of the abdominal wall. This also leaves a large defect and is difficult to perform in large abdominal walls.

5 Some surgeons have used trocars designed for use with laparoscopes for the initial entry into the peritoneal cavity. These devices allow the placement of a laparoscope through the internal diameter of the trocar and have a trocar tip that is made of clear plastic to allow the surgeon to visualize the passage of the tip through the abdominal wall. However, in order to allow the subsequent introduction of insufflation
10 gas through the cannula, the trocar and cannula must be inserted all the way through the wall of the abdomen and this in turn can be potentially dangerous as the tip of the trocar may have to advance as much as one inch beyond the distal surface of the abdominal wall and into the underlying anatomical structures. As such, there remains a need in the art for an improved surgical instrument that provides visual entry and visual
15 insufflation, and that minimizes the risks of damaging organs, tissues and vessels underlying a body wall.

SUMMARY OF THE INVENTION

The invention is directed to surgical instruments providing visual entry and
20 visual insufflation with minimal risks of injury to organs, tissues and vessels underlying a body wall. It is appreciated that the concept of the invention may be applied to any surgical instrument that provides the ability to insufflate under direct vision of the site of insufflation, regardless of the size of the instrument and

the type of insufflation fluid. More specifically, the surgical instrument provides the ability to transfer an insufflation fluid such as CO₂ or saline from outside a patient to inside a surgical cavity under vision. The insufflation fluid may be transferred inside a lumen, along a body channel or through a coiled tube of a surgical instrument or scope used for vision.

In a first embodiment of the invention, an insufflating surgical instrument adapted for movement across an abdominal wall to insufflate an abdominal region of a patient is disclosed comprising a shaft having an insufflation channel extending along an axis between a proximal end and a distal end, the insufflation channel being adapted for connection to a source of fluid under pressure at the proximal end. The insufflating surgical instrument further comprises a tip at the distal end of the shaft and at least one vent hole formed at the tip or the shaft being in connection with the insufflation channel and being adapted to expel the fluid under pressure to insufflate the abdominal region. In one aspect, at least one of the tip and the shaft is formed of a transparent material to facilitate visualization of the abdominal wall and the abdominal region. With this aspect, the shaft and the tip are configured to enable insertion of a laparoscope. In particular, the shaft includes a lumen extending along the axis between the proximal end and the distal end to enable insertion of the laparoscope. The lumen and insufflation channel may be formed as separate channels or as one shared channel. The insufflating surgical instrument may further comprise a second vent hole being in connection with the insufflation channel and formed along the shaft. It is appreciated that the tip may be blunt, the shaft and the tip may be integrally formed, and the vent hole may be of any geometric shape including round, oval, square and rectangular. With this aspect, at

least one of the tip and the shaft may be formed of a translucent or a transparent material such as polycarbonate. The blunt tip may further comprise a marker to indicate when the vent hole has been positioned for insufflation. More specifically, the marker indicates the point where the vent hole has penetrated the abdominal wall. The shaft of the invention may further comprise a scope lock to prevent the laparoscope from being inserted too far into the shaft and block at least one of the insufflation channel and the vent hole. In another aspect, the tip may be sharp, pointed or bladed to facilitate penetration of body tissue.

The insufflating surgical instrument may further comprise a seal housing disposed at the proximal end of the shaft. The seal housing comprises a septum seal and a plurality of leaflets forming an instrument seal in the presence of a laparoscope, and providing a zero seal in the absence of an instrument. The thickness of the leaflets may be formed to a desired dimension to create a pressure release mechanism that inverts and releases pressure if the abdominal pressure within the patient undergoes a sudden spike. The septum seal may be formed of an elastomeric material including Kraton, silicone and the like. The seal housing may further comprise a duckbill or a double duckbill valve distal of the leaflets to further limit gas or fluid escape.

In another aspect of the invention, an insufflating surgical instrument adapted for penetrating an abdominal wall to insufflate an abdominal region of a patient is disclosed comprising a shaft having an insufflation channel extending along an axis between a proximal end and a distal end, the insufflation channel being adapted for connection to a source of fluid under pressure at the proximal end. The insufflating surgical instrument further comprises a tip at the distal end of the shaft, the tip having a first, closed position

during penetration of the abdominal wall and a second, opened position to expel the fluid under pressure to insufflate the abdominal region after penetration of the abdominal wall. The tip may be a flip-top that automatically opens upon traversing the abdominal wall or a flapper valve that opens to the second position when gas or fluid is introduced at the source and into the insufflation channel. The insufflating surgical instrument may further comprise a retention member for connecting the shaft and the flip-top. The flip-top may be a two-piece flip-top, the flapper valve may be a reverse flapper valve or a spring-based flapper valve, and the retention member may be one of a spring, a spring wire, an offset hinge or a living hinge. In another aspect, the tip may comprise at least two petals that reposition to the side of the shaft in the second insufflation position.

Another aspect of the invention is a laparoscopic insufflating surgical instrument adapted for movement across an abdominal wall to insufflate an abdominal region of a patient comprising an elongate tube having a distal tip, an insufflation channel extending between a proximal end and a distal end, the elongate tube being adapted for connection to a source of fluid under pressure at the proximal end, and being adapted at the distal end to expel the fluid under pressure to insufflate the abdominal region, and an optical element disposed at the distal end of the elongate tube to facilitate visualization of the abdominal wall and the abdominal region. With this aspect, the distal tip is defined by a curved surface, the distal tip being translucent or transparent, and the optical element being a light or an endoscope. It is appreciated that the insufflating surgical instrument may be an insufflating Veress needle.

Another aspect of the invention is directed to a laparoscopic insufflating surgical instrument adapted for movement across an abdominal wall to insufflate an abdominal region of a patient comprising an elongate tube having a proximal end and a distal end, an optical element disposed at the distal end of the elongate tube to facilitate
5 visualization of the abdominal wall and the abdominal region of the patient, and an insufflation channel having a proximal end and a distal end extending along the proximal end and the distal end of the elongate tube, the insufflation channel being adapted for connection to a source of fluid under pressure at the proximal end, and to expel the fluid under pressure to insufflate the abdominal region at the distal end. With
10 this aspect, the insufflation channel is formed into a coil around the elongate tube. It is further appreciated that the distal end of the elongate tube may be tapered to form a generally cone-tipped end.

In yet another aspect of the invention, there is disclosed an insufflating surgical instrument adapted for movement across an abdominal wall to insufflate an abdominal
15 region of a patient, the surgical instrument comprising an insufflating cannula having a wall forming a first lumen extending along an axis between a proximal end and a distal end, and a first insufflation channel formed in the wall extending along the axis between the proximal end and the distal end and being adapted for connection to a source of fluid under pressure at the proximal end. The insufflating surgical instrument further
20 comprises an insufflating trocar having a shaft with a second lumen extending along the axis between a proximal end and a distal end, a second insufflation channel formed at the distal end and being adapted for alignment with the first insufflation channel of the cannula to expel the fluid under pressure to insufflate the abdominal region, and a tip at

the distal end of the shaft, and at least one vent hole formed at the tip of the trocar being in connection with the second insufflation channel of the trocar. The insufflating surgical instrument may further comprise a laparoscope adapted for insertion at the proximal end of the trocar and advanced to the distal end as the trocar is placed through
5 the abdominal wall.

Another aspect of the invention is directed to a method for using an insufflating surgical instrument to create access across an abdominal cavity and to insufflate an abdominal region of a patient, the method comprising providing a transparent shaft having a lumen and an insufflation channel extending along an axis between a proximal
10 end and a distal end, the insufflation channel being adapted for connection to a source of fluid under pressure at the proximal end, a tip at the distal end of the shaft, and at least one vent hole formed at the tip or the shaft being in connection with the insufflation channel and adapted to expel the fluid under pressure to insufflate the abdominal
15 region; moving the shaft across the abdominal wall to place the distal end of the shaft in the abdominal region; and expelling gas or fluid under pressure through the insufflation channel to insufflate the abdominal region of the patient. The method for using the insufflating surgical instrument may further comprise the step of visualizing the abdominal cavity through the lumen of the shaft.

These and other features of the invention will become more apparent with a
20 discussion of the various embodiments in reference to the associated drawings.

DESCRIPTION OF THE DRAWINGS

The accompanying drawings, which are included in and constitute a part of this specification, illustrate the embodiments of the invention and, together with the description, explain the features and principles of the invention. In the drawings:

5 FIG. 1 illustrates a typical laparoscopic abdominal surgery of the prior art;

FIG. 2 illustrates a perspective view of an insufflation needle of the prior art;

FIG. 3 illustrates a perspective view of an insufflating optical trocar in accordance with a first embodiment of the invention;

10 FIGS. 4(a) and 4(b) illustrate cross-sectional views of an insufflating optical trocar in accordance with another embodiment of the invention;

FIG. 5 illustrates a perspective view of a septum seal for use with the insufflating optical trocar of the invention;

FIGS. 6(a)-6(d) illustrate cross-sectional views of the septum seal for use with the insufflating optical trocar of the invention;

15 FIGS. 7(a) and 7(b) illustrate the insufflating optical trocar and cannula of the invention;

FIGS. 8(a)-8(f) illustrate different geometric shapes and patterns of the vent hole of the invention;

20 FIG. 9 illustrates an insufflating needle having a transparent distal tip and insufflating vent in accordance with another embodiment of the invention;

FIG. 10 illustrates an insufflating scope having a transparent distal tip and insufflating vent in accordance with another embodiment of the invention;

FIG. 11 illustrates an insufflating scope sleeve having a transparent distal tip and insufflating vent in accordance with another embodiment of the invention;

5 FIGS. 12(a)-12(e) illustrate additional tip designs of an insufflating optical surgical instrument in accordance with additional aspects of the invention;

FIGS. 13(a) and 13(b) illustrate a coiled insufflating optical trocar and a coiled insufflating optical trocar with a coiled tip, respectively, in accordance with additional embodiments of the invention;

10 FIGS. 14(a)-14(c) illustrate flip-top or flip-tip designs of insufflating optical surgical instruments in accordance to additional embodiments of the invention;

FIGS. 15(a)-15(c) illustrate cross-sectional views of insufflating valve vents in accordance with additional embodiments of the invention;

15 FIG. 16 illustrates a blunt tip insufflating optical instrument having an advanceable lumen in accordance with another embodiment of the invention;

FIGS. 17(a) and 17(b) illustrate an insufflating surgical instrument including an insufflating optical trocar and a cannula having a gas channel for transferring insufflation gas to the trocar in accordance with another embodiment of the invention;

20 FIG. 18 illustrates an insufflating blade actuating optical trocar in accordance with another embodiment of the invention; and

FIGS. 19(a)-19(i) illustrate additional tip designs in accordance to other aspects of the invention to facilitate penetration of body tissue.

DESCRIPTION OF THE INVENTION

Referring to FIG. 1, there is shown a typical laparoscopic abdominal surgery where an inflation needle 10 is inserted through a body or abdominal wall 15 and into an abdominal cavity 25. A gas is passed through the needle 10 to create a space within the abdominal cavity 25. This procedure is referred to as insufflation. The needle 10 is referred to as an insufflation needle and the gas supply is referred to as an insufflation gas. The insufflation needle 10 is placed through the body wall 15 blindly. In other words, there is no direct visualization of the procedure from the inside of the body wall 15. As explained earlier, the current procedure may inadvertently damage organs and tissues underlying the body or abdominal wall 15 such as major blood vessels and the intestinal tract. It is not uncommon for there to be internal structures attached to the internal side of the body wall 15. This is especially so in the case of the abdominal cavity 25. Portions of the intestines, colon and bowel may be attached to the abdominal wall 15. These attachments are referred to as adhesions.

Adhesions represent a potential complication in laparoscopic surgery. This is especially the case as the procedure is initiated using a sharp or pointed instrument such as the insufflation needle 10. The delicate internal structures that may be attached by adhesions may inadvertently be pierced by the introduction of the insufflation needle 10. This can be very serious and may go undetected for some time.

Referring to FIG. 2, the typical insufflation needle 10 comprises an elongate tubular body 12, a proximal connecting housing 14, a sharp, pointed distal tip 16 and a spring, biased internal blunt core 18 with a blunt end 24 that extends beyond the sharp

distal tip 16 under the influence of an extended compression spring 20. A typical placement of the insufflation needle 10 requires a user to push the sharp distal tip 16 into the abdominal wall 15, which pushes the blunt core 18 proximally, then continues to push until the distal end 22 is through the body wall 15. At that point, the blunt end 24
5 moves forward and thereby protects delicate structures from being inadvertently punctured by the sharp distal tip 16 of the needle 10. The safety of such a device depends to a large extent on the design and integrity of the spring 20 since the sharp distal tip 16 remains within the established internal region or body cavity 25.

Referring to FIG. 3, there is shown a perspective view of an insufflating
10 optical instrument or trocar 30 in accordance with a first embodiment of the invention. The insufflating optical trocar 30 is designed to separate tissue fibers during insertion through the body wall 15. The insufflating optical trocar 30 includes a shaft 34 having a lumen extending substantially along an axis between a proximal end and a distal end, a handle 35 disposed at the proximal
15 end of the shaft 34, and a blunt tip 32 disposed at the distal end of the shaft 34. The shaft 34 of the insufflating optical trocar 30 is sized and configured for disposition within a working channel of a cannula system as described in co-pending application Bladeless Optical Obturator, which is herein incorporated by
20 reference. With this disposition, the insufflating optical trocar 30 functions to penetrate a body or abdominal wall to provide the cannula with access across the body wall 15 and into the body cavity 25, such as the peritoneal or abdominal cavity.

In one aspect of the invention, the shaft 34 and tip 32 are integrally formed of a transparent material to enable visualization of tissue during the insertion of the insufflating optical trocar 30 through the body wall 15. The insufflating optical trocar 30 is configured to enable the insertion of a conventional laparoscope, which typically includes an imaging element and fiber optic light fibers. The tip 32 further includes at least one vent hole 36, and preferably two or more vent holes one on each side of the tip 32, for the insufflation gas to transfer from the inside of the trocar 30 into the body or abdominal cavity 25. The vent hole 36 may be chamfered on the proximal side such that the vent hole does not core tissue as the insufflating optical trocar 30 enters through the body wall 15.

The shaft 34 includes at least one shaft vent 38 and preferably a plurality of shaft vents 38 along the axis between the proximal end and the distal end. It is appreciated that vent holes 36 and shaft vents 38 may be of any geometric shape including round, oval, square, rectangular, etc., as illustrated in FIGS. 8(a)-8(c) and may be configured in different patterns such as a waffle pattern as illustrated in FIG. 8(f). Furthermore, the tip 32 may be an open tip 180 or a non-coring tip 182 as illustrated in FIGS. 8(d) and 8(e), respectively, to allow the transfer of insufflation gas into the body cavity 25. Advantages of the shaft vents 38 include supporting a plurality of core pins during the injection molding process of the shaft 34 to provide a uniform part thickness, and allowing the insufflation gas to transfer from the inner diameter of the cannula and seal housing into the inner diameter of the insufflating optical trocar 30 and consequently out of the vent holes 36 at tip 32.

Referring to FIGS. 4(a) and 4(b), there are shown side cross-sectional views of an insufflating optical trocar 40 in accordance with another embodiment of the invention. The insufflating optical trocar 40 includes a shaft 34b having a lumen extending substantially along an axis between a proximal end and a distal end, and a blunt tip 32b disposed at the distal end. The insufflating optical trocar 40 further includes at least one gas channel 42 extending along the length of the shaft 34b to provide rapid gas transfer through the insufflating optical trocar 40 when a scope has been placed within the inner diameter. It is appreciated that there may be more than one gas channel 42 extending along the length of the shaft 34b to provide rapid gas transfer through the trocar 40. It is further appreciated that the gas channel 42 may be formed as a separate channel or as the same channel for inserting the scope, that is, by increasing the inner diameter of the shaft 34b to be bigger than the diameter of the scope. More specifically, even if the scope and gas share the same channel, the gas channel 42 assures that there is sufficient cross-sectional area for the gas to travel along the side of the scope and down to the vent hole(s) 36b even when the scope is in place.

The tip 32b may further include a marker 46 to be used as a visible reference point. The marker 46, together with an area indicated by reference number 44 as shown in FIG. 4A, depict the down vent of the insufflating optical trocar 40 that transfers the gas from the gas channel 42 of the trocar 40 to the vent holes 36b at tip 32b. For example, as the trocar 40 is being placed through the abdominal wall 15, at some point the tip 32b of the trocar 40 will penetrate

the peritoneum. Once the peritoneum can be seen through the tip 32b and once the peritoneum is above the visible marker 46, the insufflation gas can be turned on and insufflation can begin. As such, this marks the point where the vent hole 36b is within the abdominal cavity. Once the insufflation gas has created

5 sufficient space between the abdominal wall and the organ bed, the remainder of the insufflating optical trocar 40 including the cannula system can then be fully inserted to an operative position.

The insufflating optical trocar 40 may further include a scope stop 48 as illustrated in FIG. 4(b) to keep a scope from being inserted into the taper of the inner diameter of the trocar 40. The scope stop 48 may further include a ledge 10 that further prevent the possibility of the scope from being inserted too far into the trocar and consequently block the distal portion of the gas channel 42.

Referring to FIG. 5, there is shown a perspective view of a septum seal 50 to be used with the insufflating optical trocar of the invention. The septum seal 15 50 includes a tubular body 52, a septum ring 53 and a plurality of leaflets 54 formed by a slit 56 providing an instrument seal when a scope is inserted into the insufflating optical trocar and a zero seal when the scope is withdrawn from the trocar. In addition, the thickness of the leaflets 54 can be controlled such that a pressure release mechanism can be created and consequently allowing the 20 leaflets 54 to invert and release pressure if the abdominal pressure within the patient undergoes a sudden spike. Referring to FIGS. 6(a)-6(d), there are shown cross-sectional views of the septum seal 50 of FIG. 5. The septum seal 50 further includes a retaining ledge 58, which allows the septum seal 50 to be

attached to the cap or handle 35 of the insufflating optical trocar, and also serves as a sealing surface. Reference number 59 illustrates a sealing surface between the septum seal 50 and the cap or handle of the insufflating optical trocar. The septum seal 50 may further comprise a duckbill or double duckbill valve placed
5 distally of the leaflets 54 to further limit gas or fluid escape.

During use, the insufflating optical trocar 30 is first inserted into a seal housing 84 and cannula 70 as illustrated in FIG. 7(a). A conventional laparoscope 72 is then inserted into the proximal end of the insufflating optical trocar 30 and advanced to the distal end of the trocar 30. An endoscopic video
10 camera is attached to the proximal end of the laparoscope 72. The trocar 30 is then axially advanced by the surgeon through the body wall 15. As the surgeon advances the cannula 70 and trocar 30 through the body wall 15, the surgeon can visually observe tissue of the body wall 15 as it is being separated via a video monitor, which is connected to the endoscopic video camera. The surgeon
15 can also readily determine when the body wall 15 has been completely traversed by the trocar 30. Once the trocar 30 has traversed the body wall 15, the trocar 30 and laparoscope 72 may be removed which leaves the cannula 70 disposed across the body wall 15 to provide an access channel into the body cavity 25 for the insertion of laparoscopic instrumentation.

20 As illustrated in FIG. 7(a), the insufflating optical trocar 30 is designed for use with the seal housing 84 and cannula 70. The tip 32 may be blunt and does not include any sharp edges, piercing points or blades. With this aspect of the invention, the tip 32 of the bladeless insufflating optical trocar 30 is transparent and generally hollow. This

enables a clear view through the distal tip of the insufflating optical trocar 30 and increases the visibility of tissue as it is being traversed. The obturator shaft 34 with the integral tip 32 may be formed of a transparent material such as polycarbonate. The septum seal 50, which may be formed of a material such as Kraton, silicone and the like, may be snap fitted onto the proximal end of the obturator shaft 34. The seal housing 84 may further include a handle attachment 35 including a cannula seal, which may be formed of a plastic material such as polycarbonate, that operates to attach the trocar 30 to the cannula 70 so as to maintain axial position during insertion. The diameter of the shaft 34 can range from about 2 mm to 50 mm and is designed to fit within the seal housing 84 and cannula 70.

Referring to FIG. 7(b), the cannula 70 is designed to releasably attach to the seal housing 84 via cannula seal 80a, 80b. As the shaft 34 is inserted into the seal housing 84 and cannula 70, the cannula seal 80a, 80b passively engages the seal housing 84 and serves to axially lock the shaft 34 to the seal housing 84 and cannula 70. To release the shaft 34 from the seal housing 84 and cannula 70, outboard tabs on shaft 34 are depressed inwardly and the shaft 34 is then free to be slidably removed. The shaft 34 includes axial key members 37 (see FIG. 3) at its proximal end which are designed to mate with axial keyways on the seal housing 84. As the shaft 34 is inserted into the seal housing 84 and cannula 70, the shaft 34 is rotated slightly to align key members 37 with the keyways and then advanced until the cannula seal 80a, 80b engages the seal housing 84. The key members 37 serve to rotationally index the shaft 34 to the seal housing 84. In another aspect, cannula 70 may further include distal

cannula seal 82 formed at a distal portion of cannula 70 and shaft 34 so as to further limit gas or fluid escape.

In another aspect of the invention, the insufflating optical trocar 30 may include a laparoscope lock 86 having an elastomeric element. The addition of the elastomeric element would enhance the frictional engagement with the laparoscope 72. An
5 example of an elastomeric element would be a silicone O-ring sized with an inside diameter smaller than the outside diameter of the laparoscope 72. The laparoscope lock 86 could either rotate freely to enable the laparoscope 72 to rotate freely relative to the shaft 34 or the laparoscope lock 86 could be rotationally fixed to prevent the
10 laparoscope 72 from rotating relative to the shaft 34.

In another aspect of the invention, a process of placing and using the insufflating optical trocar of the invention is described. First, the skin around the area to be operated on is incised appropriately for the size of the cannula 70. An insufflation gas line 90, which is attached to the seal housing 84, the insufflating optical trocar 30 and
15 the laparoscope 72 are then inserted into the cannula 70. At this point the gas supply is still turned off. The assembled device is then advanced through the body or abdominal wall 15 under direct vision until it is observed that just the tip 32 of the device has penetrated the peritoneal cavity. The device is then held in place and the flow of insufflation gas is begun. The gas will flow through the tip 32 and into the peritoneal
20 cavity until the cavity is sufficiently distended by gas pressure. The surgeon then completes the insertion of the insufflating optical trocar 30 until the cannula 70 is in an appropriate or desired position. The insufflating optical trocar 30 and laparoscope 72 may then be removed. At this point, the surgeon may elect to reinsert just the

laparoscope 72 through the seal housing 84 and thereby allow observation of the abdominal cavity and subsequent insertions of additional laparoscopic instrumentation.

As explained earlier, an indicator line or marker 46 as shown in FIG. 4(a) may be located on tip 32 to be viewed by laparoscope 72 to indicate when the device has advanced far enough into the body cavity to begin insufflation. The coincidence of anatomical features with the indicator line or marker 46 may indicate the correct position to begin insufflation. The indicator line or marker 46 could be circumferential in nature and when the peritoneal layer, as it is being penetrated, forms a coincident circle with respect to the indicator line 46, the surgeon can begin insufflating. Another method is to employ an O-ring seal 86. Additionally, it is preferred that a zero seal be present on the trocar to prevent escape of the gas when the trocar is used to place cannulas without the laparoscope 72. A double duckbill valve 88 would work well too for this application as would a single duckbill, a flapper valve or a slit valve.

It is appreciated that the above-described concept may be applied to any surgical instruments providing visual entry and visual insufflation, regardless of size or type of fluid transfer as further described in the following exemplary embodiments of the invention. For example, FIG. 9 illustrates an insufflating needle 190 in accordance with another aspect of the invention comprising an elongate tubular body 192 having an insufflation channel extending along an axis between a proximal end and a distal end, a transparent distal tip 194 operably attached to the distal end of the tubular body 192, and at least one insufflating vent hole 196 formed at the distal tip 194 or tubular body 192 and being in connection with the insufflation channel. The insufflating needle 190 may further include an insufflation-controlling device 198 such as a stopcock and a

sealing mechanism 200 at the proximal end of the tubular body 192. A small diameter scope 202 may be inserted at the proximal end of the tubular body 192 and then advanced to the distal end of the tubular body 192 as the insufflating needle 190 such as an insufflating Veress needle is placed through an abdominal wall. In yet another aspect of the invention as illustrated in FIG. 10, an insufflating scope 210 comprises an elongate body 212 having an insufflation channel 224 extending along an axis between a proximal end and a distal end, a transparent tip 214 operably attached to the distal end of the elongate body 212 and having at least one insufflating vent hole 216 being in connection with the insufflation channel 224, and a handle 218 formed at the proximal end of the elongate body 212. The insufflating scope 210 may further include an insufflation-controlling device 220 such as a stopcock at the proximal end of the elongate body 212 or on the handle 218. The elongate body 212 includes an optical element 222 that directs light to the tip 214 and at least one insufflation channel 224 to transfer the insufflation gas into the surgical cavity.

Referring to FIG. 11, there is shown an insufflating scope sleeve 230 in accordance with another embodiment of the invention. The insufflating scope sleeve 230 comprises a flexible sleeve 232 having a proximal end and a distal end, a transparent tip 234 operably attached to the distal end of the flexible sleeve 232 and having at least one insufflating vent hole 236, and a handle 238 attached to the proximal end of the flexible sleeve 232. The insufflating sleeve 230 may further include an insufflation-controlling device 240 such as a stopcock and a sealing mechanism 242 at the proximal end of the insufflating sleeve 230. A scope 244 may be inserted at the proximal end of the insufflating scope sleeve 230 and then advanced to the distal end of

the insufflating scope sleeve 230 as the insufflating scope sleeve 230 is placed through an abdominal wall.

Referring to FIGS. 12(a)-12(e), there are shown additional tip designs 32o-32s in accordance with other aspects of the invention to facilitate penetration of a body tissue.

5 FIG. 12(a) illustrates a spoon-shaped or asymmetric tip 32o having at least one vent hole 36o; FIG. 12(b) illustrates a generally domed or conical shaped tip 32p having plastic or metal blades 33p along an axis of the shaft and at least one vent hole 36p; FIG. 12(c) illustrates a blunt tip 32q having at least one vent hole 36q; FIG. 12(d) illustrates a generally domed or conical shaped tip 32r having at least one bladed fin 33r
10 and at least one vent hole 36r; and FIG. 12(e) illustrates a generally conical shaped tip 32s having at least one vent hole 36s at the distal tip. It is appreciated that tips 32o, 32p, 32r and 32s have a sharp, pointed or bladed tip and/or edge to facilitate penetration of body tissue. In yet other aspects of the invention, the surface of the tip may have at least one tissue engaging raised pattern on the surface. The surface
15 operates to facilitate insertion of the insufflating surgical instrument or optical trocar with a reduced penetration force and minimize tenting of the body wall. The surface may further facilitate separation of different layers of the body wall and provides proper alignment of the tip between the layers. In another aspect of the invention, the tip may have an outer surface extending distally to a blunt point and includes a pair of side
20 sections separated by an intermediate section, and wherein the side sections extend from the blunt point radially outwardly with progressive positions proximally along the axis. The side sections may include a distal portion in proximity to the blunt point and a

proximal portion in proximity to the tubular body, and the distal portion of the side sections being twisted radially with respect to the proximal portion of the side sections.

FIGS. 13(a) and 13(b) illustrate a coiled insufflating optical trocar 250 and a coiled insufflating optical trocar with a coiled tip 260, respectively, in accordance with additional embodiments of the invention. The coiled insufflating optical trocar 250 comprises a shaft 34t having a lumen and a hollow coiled tube or gas channel 42t wrapped substantially along the length of the shaft 34t to provide gas transfer into the body cavity. An advantage of this aspect of the invention is coiling also helps to keep the trocar from moving about inside a body cavity. The coiled insufflating optical trocar 250 may further include an insufflation-controlling device 240 such as a stopcock at the proximal end of the coiled insufflating optical trocar 250. A scope may be inserted at the proximal end of the coiled insufflating optical trocar 250 and then advanced to the distal end of the trocar 250 as the trocar 250 is placed through an abdominal wall. The coiled insufflating optical trocar with coiled tip 260 as shown in FIG. 13(b) is similar to the coiled insufflating optical trocar 250 but further includes a tip 32u and a hollow coiled tube or gas channel 42u that wraps around the tip 32u and substantially along the length of the shaft 34u.

Referring to FIGS. 14(a)-14(c), there are shown additional tip designs 32v-32x in accordance to other aspects of the invention. For example, the tip 32v as illustrated in FIG. 14(a) comprises a flip-top 272 and a conical body 270 that operates to move from a first, penetrating position to a second, insufflating position when the body wall has been traversed. The tip 32v may further comprise a retention member for connecting the flip-top 272 and the conical body 270. The retention member may be one of a

spring, a spring wire, an offset hinge or a "living" hinge. Other flip-top or flip-tip designs as described in co-pending U.S. Patent Application Serial No. 10/805,864, entitled "Surgical Access Port and Method of Using Same," filed March 22, 2004, which is herein incorporated by reference, may also be used with the insufflating concept of the invention. In yet another aspect of the invention, the tip 32w as illustrated in FIG. 14(b) comprises a two-piece flip-top 282a, 282b that operates to move from a first, penetrating position to a second, insufflating position when the body wall has been traversed. In particular, the tip 32w may comprise at least two or more parts or petals that reposition to the side of the shaft 34w in the second, insufflating position. FIG. 14(c) illustrates the tip 32x in accordance with another aspect of the invention comprising a two-stage flip-top 290 that operates to move from a penetrating position to an insufflating position and then to an instrument access position. In particular, the two-stage flip-top 290 comprises a distal flip portion 292 and a proximal flip portion 294. In the first stage, the distal flip portion 292 moves from a penetrating position to an open or insufflating position once the body wall has been traversed. Once insufflation has been achieved, the proximal flip portion 294 moves to an open or instrument access position in the second stage. The tip 32x may further comprise retention members for connecting between the distal flip portion 292 and the proximal flip portion 294, and between the proximal flip portion 294 and the shaft 34x.

FIGS. 15(a)-15(c) illustrate insufflating valve vents in accordance with additional aspects of the invention. More specifically, FIG. 15(a) illustrates an insufflating valve vent 300 formed at the distal end of the shaft 34. The insufflating valve vent 300 is formed of an elastic material to allow gas such as CO₂ to be introduced from the inside

of the shaft 34 to a body cavity. It is appreciated that when there is no gas, the elastic material of the insufflating valve vent 300 causes it to close so as to provide an airtight seal. FIG. 15(b) illustrates an insufflating flapper valve 310 formed at tip 32y of an insufflating optical trocar. The insufflating flapper valve 310 comprises at least one
5 flapper valve vent 312 that operates to open when a gas such as CO₂ is introduced in the shaft 34. It is appreciated that when there is no gas, the flapper valve vent 312 closes to provide a tight seal. Similarly to FIG. 15(b), FIG. 15(c) illustrates an insufflating reverse flapper valve 320 formed at tip 32z of an insufflating optical trocar. The insufflating reverse flapper valve 320 comprises at least one flapper valve vent 322
10 that remains close or shut by tissue during insertion, and once peritoneum is passed, pressure by a gas such as CO₂ would then open the reverse flapper valve 320 to allow the transfer of the gas into a body cavity. It is appreciated that each of the above flapper valve vents may be spring loaded to operate like a Veress needle.

FIG. 16 illustrates a blunt tip insufflating optical instrument 400 in accordance
15 with another embodiment of the invention. The blunt tip insufflating optical instrument 400 comprises an elongate tubular body 410 extending along an axis between a proximal end and a distal end, a blunt tip optical obturator or separator 420 to be inserted through the tubular body 410 and into a body cavity, and an advanceable insufflation channel 430 extending along the length of the tubular body 410 and into the
20 body cavity. The blunt tip optical obturator or separator 420 operates to provide visibility down to the peritoneum at which time the insufflation channel 430 may be advanced through the peritoneum to provide gas and/or saline to the body cavity until sufficient space is achieved. Once gas and/or saline have been sufficiently introduced, the blunt

tip optical obturator 420 and tubular body 410 may be advanced into the body cavity. A feature of this aspect of the invention is the insufflation channel 430 may be advanced ahead of the blunt tip optical obturator or separator 420 to puncture peritoneum to transfer gas such as CO₂ to the body cavity.

5 Referring to FIGS. 17(a) and 17(b), there are shown illustrations of an insufflating surgical instrument 500 in accordance with another embodiment of the invention. The insufflating surgical instrument 500 comprises an insufflating optical trocar 502 and a cannula 520. The insufflating optical trocar 502 comprises a shaft 504 having a lumen extending along an axis between a proximal end and a distal end, a tip 506 disposed at
10 a distal end of the shaft, at least one vent hole 508 to introduce gas from the cannula 520 into the body or abdominal cavity as further discussed below, and a gas channel 510 formed in either the shaft 504 or the tip 506 and operably connected to the at least one vent hole 508 to allow gas transfer from the cannula 520 to the insufflating optical trocar 502. The cannula 520 comprises at least one cannula gas channel 522
15 extending along its longitudinal axis to transfer gas to the trocar gas channel 510 after insertion of the insufflating optical trocar 502 into the cannula 520. In other words, the cannula gas channel 522 is encased as a lumen in the cannula wall. During operation, the transfer of gas only takes place if there is an alignment between the cannula gas channel 522 and the trocar gas channel 510 as illustrated in FIGS. 17(a) and 17(b). A
20 scope 525 may be inserted at the proximal end of the insufflating optical trocar 502 and then advanced to the distal end of the trocar 502 as the trocar 502 is placed through an abdominal wall.

In yet another aspect of the invention, FIG. 18 illustrates an insufflating blade actuating optical instrument 600 in accordance with another embodiment of the invention. The insufflating blade actuating optical instrument 600 comprises an elongate tubular member 602 extending along a longitudinal axis between a proximal end and a distal end, an optical member 604 operably attached at the distal end of the elongate member 602, at least one blade member 606 being longitudinally movable between deployed and nondeployed positions, an actuating mechanism 608 operably attached at the proximal end of the tubular member 602 for moving the blade member 606 between the deployed and nondeployed positions, and at least one insufflating vent 610 formed in the optical member 604 to transfer insufflation gas from outside a body cavity to inside the body cavity. A scope may be inserted at the proximal end of the insufflating blade actuating optical instrument 600 and then advanced to the distal end of the instrument 600 as the insufflating blade actuating optical instrument 600 is placed through an abdominal wall.

Referring to FIGS. 19(a)-19(i), there are shown additional tip designs 32aa-32ii in accordance to other aspects of the invention to facilitate penetration of a body tissue. Each of these tip designs includes at least one vent hole (36aa-36ii) at the distal tip to introduce insufflation gas into a body cavity. It is appreciated that some of these tips have a sharp, pointed or bladed tip and/or edge to facilitate penetration of body tissue.

It is appreciated that the above described surgical instruments and devices can be used to access not only the peritoneal cavity but can be used for preperitoneal hernia repair, retroperitoneal operations including back and kidney operations, percutaneous kidney operations, thoracic surgery and arthroscopic access. In addition

to gas such as carbon dioxide, it is appreciated that other fluids such as air, water and saline can also be introduced into a body cavity with the technique of the invention. It is appreciated that operating scopes may be modified such that a lumen may be used to introduce insufflation fluid. Accordingly, it is understood that many other modifications
5 can be made to the various disclosed embodiments without departing from the spirit and scope of the invention. For these reasons, the above description should not be construed as limiting the invention, but should be interpreted as merely exemplary embodiments.

CLAIMS

1. An insufflating surgical instrument adapted for movement across an abdominal wall to insufflate an abdominal region of a patient, comprising:

a shaft having an insufflation channel extending along an axis between a proximal end and a distal end, the insufflation channel being adapted for connection to a source of fluid under pressure at the proximal end;

a tip at the distal end of the shaft; and

at least one vent hole formed at the tip or along the shaft, the vent hole being in connection with the insufflation channel and being adapted to expel the fluid under pressure to insufflate the abdominal region.

2. The insufflating surgical instrument of claim 1, wherein at least one of the tip and the shaft is formed of a transparent material to facilitate visualization of the abdominal wall and the abdominal region.

3. The insufflating surgical instrument of claim 1, wherein the shaft and the tip are configured to enable insertion of a laparoscope.

4. The insufflating surgical instrument of claim 3, wherein the shaft has a lumen extending along the axis between the proximal end and the distal end to enable insertion of the laparoscope.

5. The insufflating surgical instrument of claim 4, wherein the lumen and the insufflation channel are separated.
6. The insufflating surgical instrument of claim 4, wherein the lumen and the insufflation channel are combined as one channel.
7. The insufflating surgical instrument of claim 1, further comprising a second vent hole being in connection with the insufflation channel and formed along the shaft.
8. The insufflating surgical instrument of claim 1, wherein the tip is blunt.
9. The insufflating surgical instrument of claim 1, wherein the shaft and the tip are integrally formed.
10. The insufflating surgical instrument of claim 1, wherein the vent hole may be of any geometric shape including round, oval, square and rectangular.
11. The insufflating surgical instrument of claim 8, wherein the blunt tip further comprises a marker to indicate when the vent hole is positioned for insufflation.

12. The insufflating surgical instrument of claim 11, wherein the marker
5 indicates the point where the vent hole has penetrated the abdominal wall.

13. The insufflating surgical instrument of claim 3, wherein the shaft further
comprises a scope stop to prevent the laparoscope from being inserted too far into the
shaft and block at least one of the insufflation channel and the vent hole.

14. The insufflating surgical instrument of claim 1, further comprising a seal
housing disposed at the proximal end of the shaft.

15. The insufflating surgical instrument of claim 14, wherein the seal housing
comprises a septum seal and a plurality of leaflets forming an instrument seal in the
presence of a laparoscope, and providing a zero seal in the absence of an instrument.

16. The insufflating surgical instrument of claim 15, wherein the thickness of
the leaflets may be formed to a desired dimension to create a pressure release
mechanism that inverts and releases pressure if the abdominal pressure within the
patient undergoes a sudden spike.

17. The insufflating surgical instrument of claim 8, wherein the blunt tip is
hollow.

18. The insufflating surgical instrument of claim 1, wherein at least one of the tip and the shaft is formed of a translucent material.
19. The insufflating surgical instrument of claim 2 or 18, wherein the translucent or transparent material is polycarbonate.
20. The insufflating surgical instrument of claim 15, wherein the septum seal is formed of an elastomeric material including Kraton, silicone and the like.
21. The insufflating surgical instrument of claim 1, wherein the shaft has a diameter ranging from about 2 mm to about 5 mm.
22. The insufflating surgical instrument of claim 1, wherein the tip is sharp, pointed or bladed to facilitate penetration of body tissue.
23. The insufflating surgical instrument of claim 22, wherein the tip is asymmetric.
24. The insufflating surgical instrument of claim 1, wherein the tip is generally domed or conically shaped.

25. The insufflating surgical instrument of claim 24, further comprising at least one blade formed on the shaft or the tip.

26. The insufflating surgical instrument of claim 3, further comprising an elastomeric lock placed on the inner diameter of the shaft for locking the laparoscope.

27. The insufflating surgical instrument of claim 26, wherein the laparoscope lock is a silicone O-ring sized and configured to rotate freely to enable the laparoscope to rotate freely relative with the shaft.

28. The insufflating surgical instrument of claim 26, wherein the laparoscope lock is rotationally fixed to prevent the laparoscope from rotating relative to the shaft.

29. The insufflating surgical instrument of claim 1, wherein the shaft is formed of a flexible sleeve.

30. An insufflating surgical instrument adapted for penetrating an abdominal wall to insufflate an abdominal region of a patient, comprising:

a shaft having an insufflation channel extending along an axis between a proximal end and a distal end, the insufflation channel being adapted for connection to a

5 source of fluid under pressure at the proximal end; and

a tip at the distal end of the shaft, the tip having a first, closed position during penetration of the abdominal wall and a second, opened position to expel the fluid under pressure to insufflate the abdominal region after penetration of the abdominal wall.

31. The insufflating surgical instrument of claim 30, wherein the tip is a flip-top that automatically opens upon traversing the abdominal wall.

32. The insufflating surgical instrument of claim 31, further comprising a retention member for connecting the shaft and the flip-top.

33. The insufflating surgical instrument of claim 30, wherein the tip is a flapper valve that opens to the second position when gas or fluid is introduced at the source and into the insufflation channel.

34. The insufflating surgical instrument of claim 33, wherein the flapper valve is a reverse flapper valve.

35. The insufflating surgical instrument of claim 33, wherein the flapper valve is a spring-based flapper valve.

36. The insufflating surgical instrument of claim 32, wherein the retention member is one of a spring, a spring wire, an offset hinge or a living hinge.

37. The insufflating surgical instrument of claim 31, wherein the flip-top is a two-piece flip-top.

38. The insufflating surgical instrument of claim 31, wherein the tip comprises at least two petals that reposition to the side of the shaft in the second insufflation position.

39. A laparoscopic insufflating surgical instrument adapted for movement across an abdominal wall to insufflate an abdominal region of a patient, comprising:

an elongate tube having a proximal end and a distal end;

an optical element disposed at the distal end of the elongate tube to facilitate
5 visualization of the abdominal wall and the abdominal region of the patient; and

an insufflation channel having a proximal end and a distal end extending along the proximal end and the distal end of the elongate tube, the insufflation channel being adapted for connection to a source of fluid under pressure at the proximal end, and to expel the fluid under pressure to insufflate the abdominal region at the distal end.

40. The laparoscopic insufflating surgical instrument of claim 39, wherein the insufflation channel is formed into a coil around the elongate tube.

41. The laparoscopic insufflating surgical instrument of claim 40, wherein the distal end of the elongate tube is tapered to form a generally cone-tipped end.

42. An insufflating surgical instrument adapted for movement across an abdominal wall to insufflate an abdominal region of a patient, comprising:

an insufflating cannula having a wall forming a first lumen extending along an axis between a proximal end and a distal end, and a first insufflation channel formed in the wall extending along the axis between the proximal end and the distal end and being adapted for connection to a source of fluid under pressure at the proximal end;

an insufflating trocar having a shaft with a second lumen extending along the axis between a proximal end and a distal end, a second insufflation channel formed at the distal end and being adapted for alignment with the first insufflation channel of the cannula to expel the fluid under pressure to insufflate the abdominal region, and a tip at the distal end of the shaft; and

at least one vent hole formed at the tip of the trocar being in connection with the second insufflation channel of the trocar.

43. The insufflating surgical instrument of claim 42, further comprising a laparoscope adapted for insertion at the proximal end of the trocar and advanced to the distal end as the trocar is placed through the abdominal wall.

44. A method for using an insufflating surgical instrument to create access across an abdominal cavity and to insufflate an abdominal region of a patient, comprising:

- 5 providing a transparent shaft having a lumen and an insufflation channel extending along an axis between a proximal end and a distal end, the insufflation channel being adapted for connection to a source of fluid under pressure at the proximal end, a tip at the distal end of the shaft, and at least one vent hole formed at the tip or along the shaft, the vent hole being in connection with the insufflation channel and adapted to expel the fluid under pressure to insufflate the abdominal region;
- 10 moving the shaft across the abdominal wall to place the distal end of the shaft in the abdominal region; and
- expelling gas or fluid under pressure through the insufflation channel to insufflate the abdominal region of the patient.

45. The method for using an insufflating surgical instrument of claim 44, further comprising the step of visualizing the abdominal cavity through the lumen of the shaft.

46. An insufflating surgical instrument adapted for movement across an abdominal wall to insufflate an abdominal region of a patient, comprising:

a shaft having an insufflation channel extending along an axis between a proximal end and a distal end, the insufflation channel being adapted for connection to a source of fluid under pressure at the proximal end;

a tip at the distal end of the shaft; and

means for expelling the fluid under pressure to insufflate the abdominal region, the expelling means being formed at the tip or along the shaft and being in connection with the insufflation channel.

47. The insufflating surgical instrument of claim 46, wherein the expelling means includes at least one vent hole formed at the tip.

48. The insufflating surgical instrument of claim 46, wherein at least one of the tip and the shaft is formed of a transparent material to facilitate visualization of the abdominal wall and the abdominal region.

49. The insufflating surgical instrument of claim 46, wherein the tip is blunt.

50. The insufflating surgical instrument of claim 49, wherein the blunt tip further comprises a marker indicating a point where the expelling means has penetrated
5 the abdominal wall.

51. The insufflating surgical instrument of claim 46, wherein at least one of the tip and the shaft is formed of a translucent material.

52. The insufflating surgical instrument of claim 48 or 51, wherein the translucent or transparent material is polycarbonate.

53. The insufflating surgical instrument of claim 46, wherein the tip is sharp, pointed or bladed to facilitate penetration of body tissue.

54. The insufflating surgical instrument of claim 46, wherein the tip is generally domed or conically shaped.

55. The insufflating surgical instrument of claim 54, further comprising at least one blade formed on the shaft or the tip.

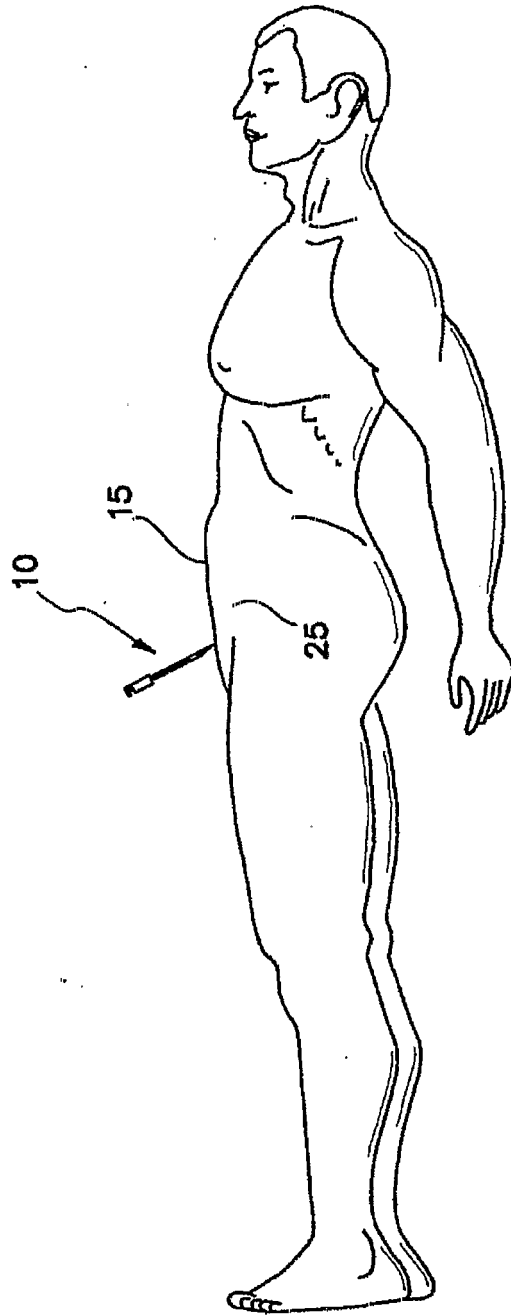

FIG. 1
PRIOR ART

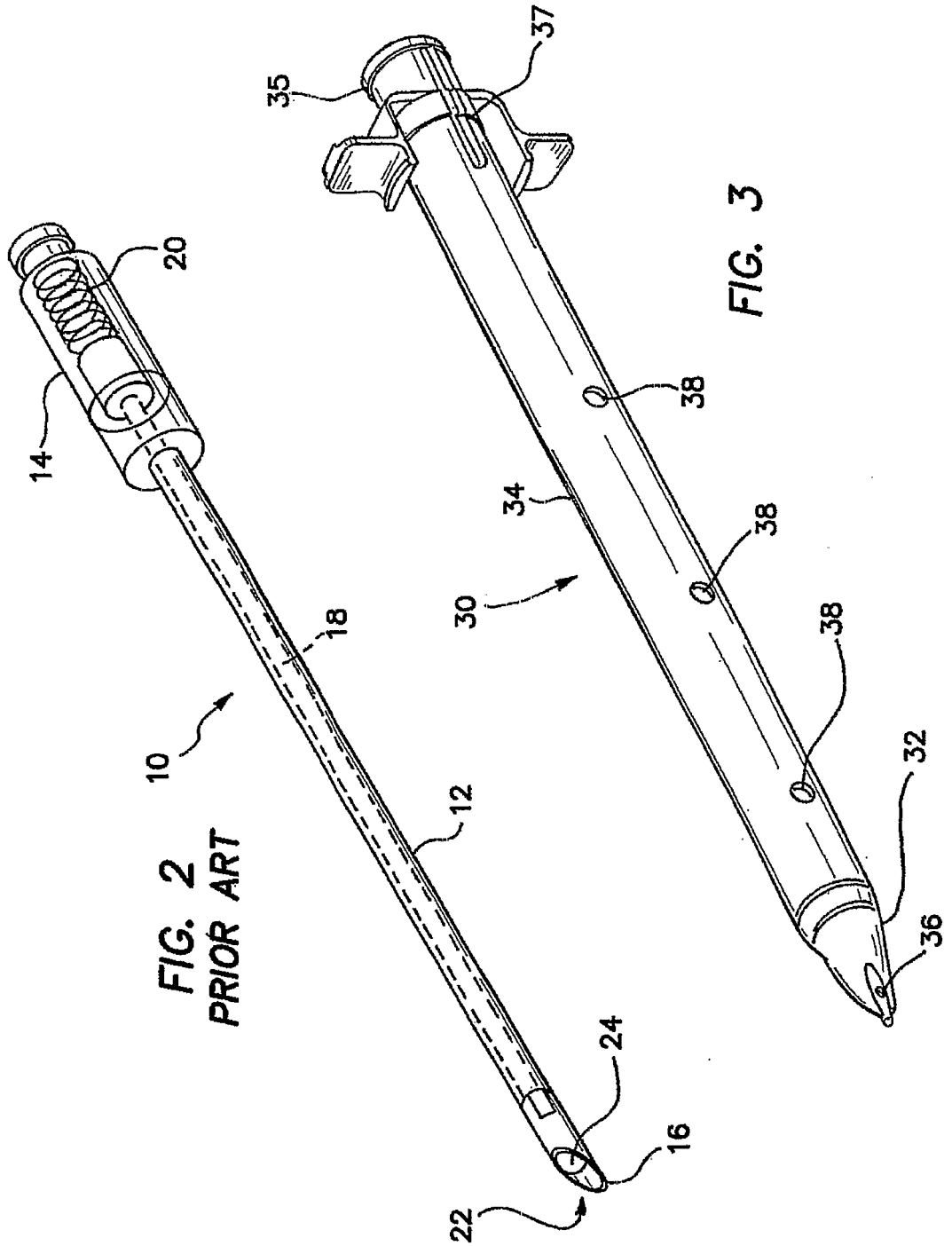
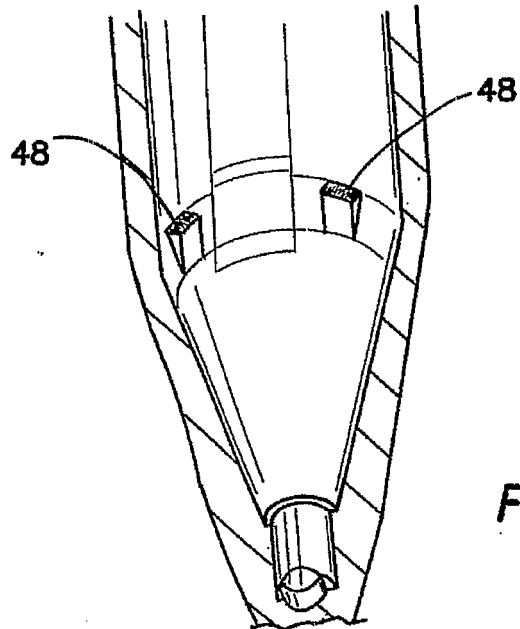
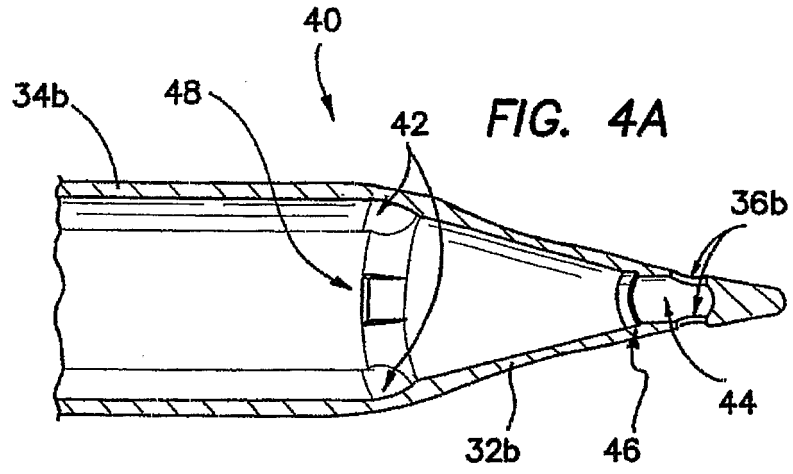

FIG. 2
PRIOR ART

FIG. 3



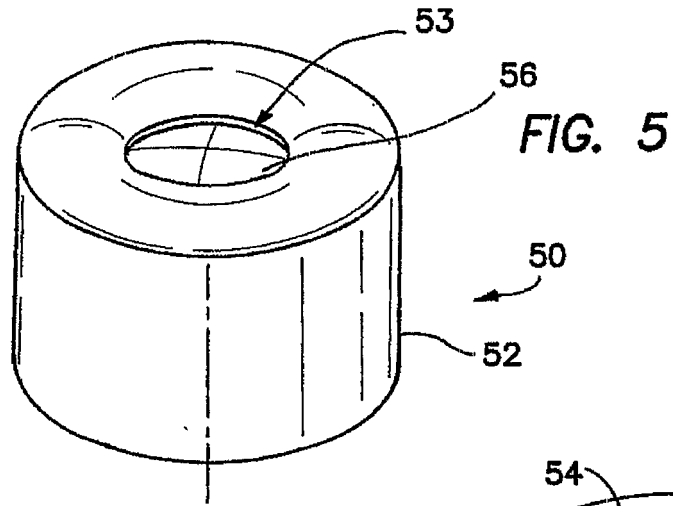
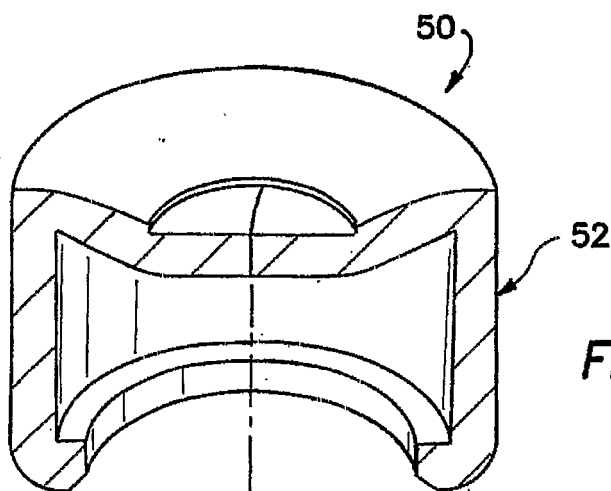
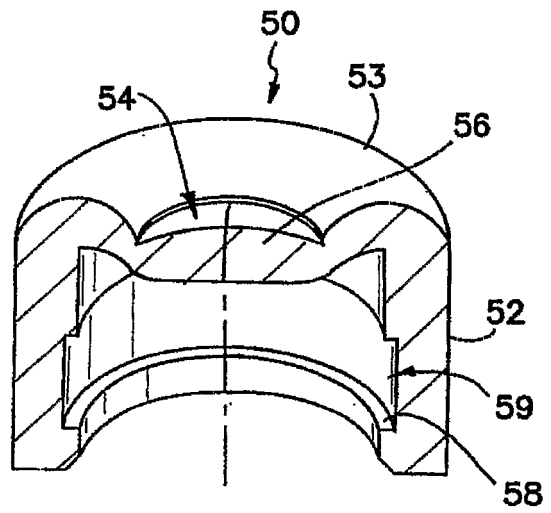

FIG. 6A



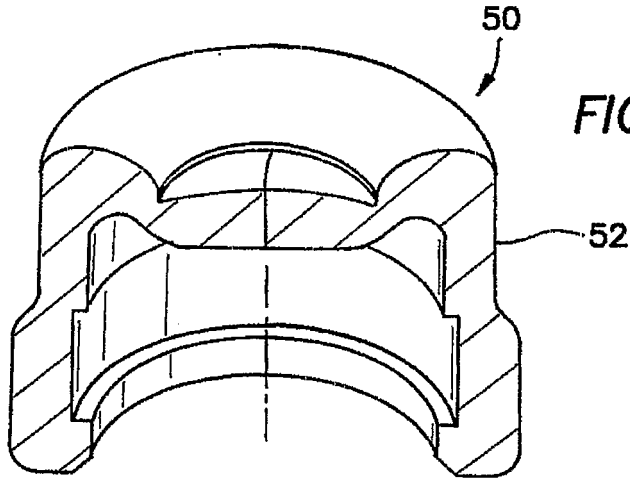

FIG. 6C

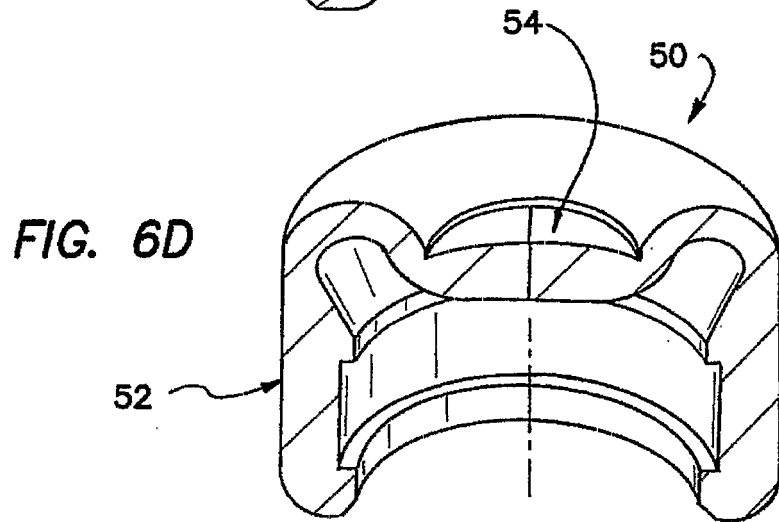

FIG. 6D

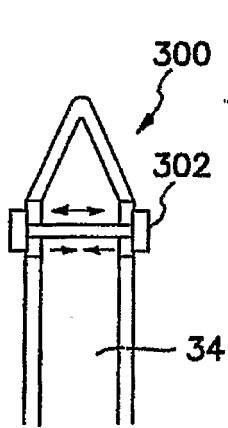

FIG. 15A

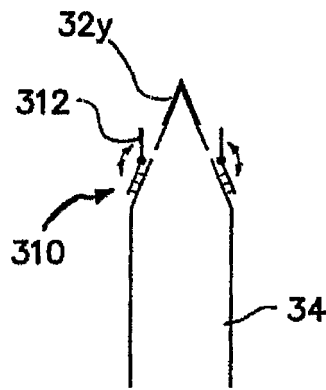

FIG. 15B

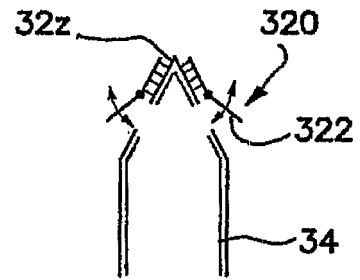

FIG. 15C

FIG. 7A

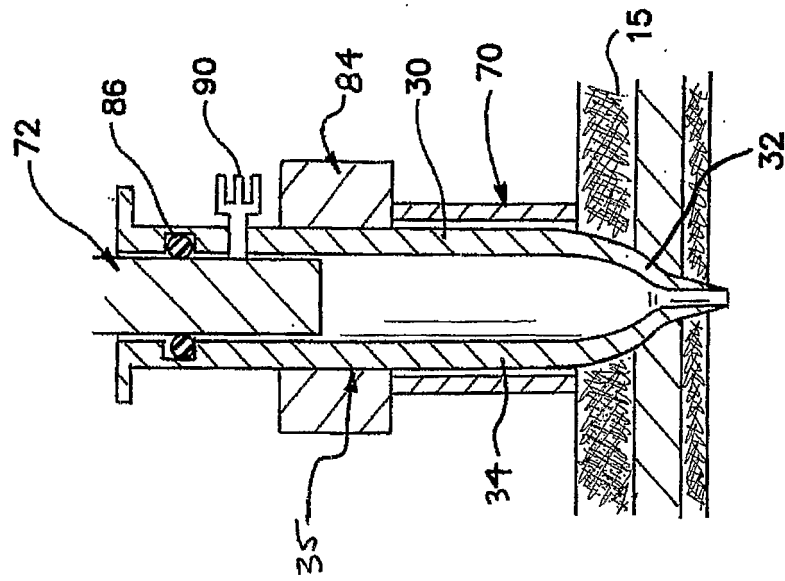

FIG. 7B

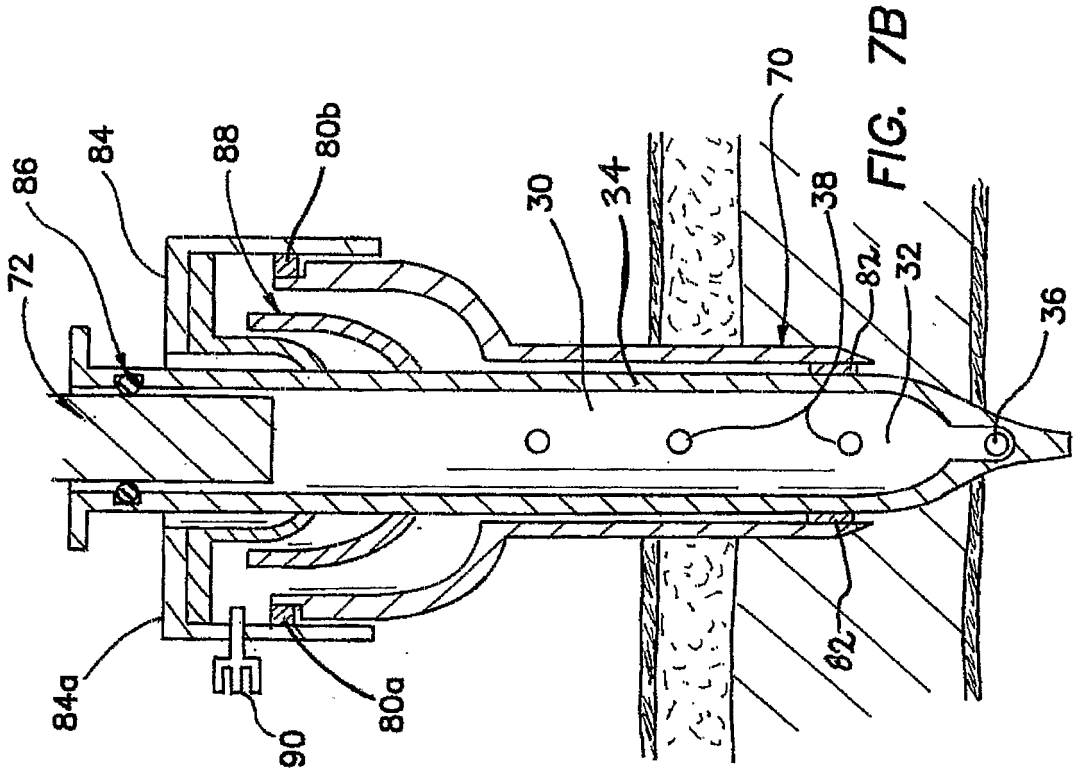



FIG. 8A

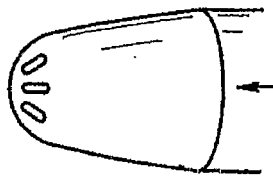

FIG. 8B



FIG. 8C

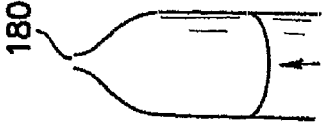

FIG. 8D



FIG. 8E

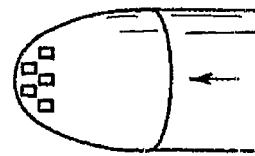

FIG. 8F

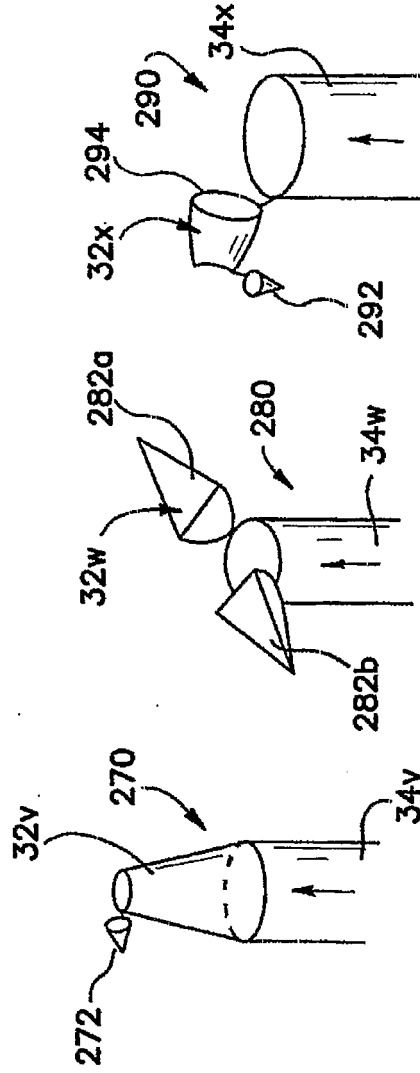

FIG. 14A

FIG. 14B

FIG. 14C

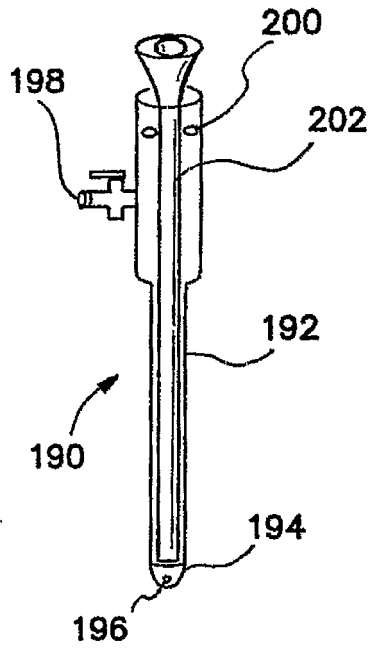

FIG. 9

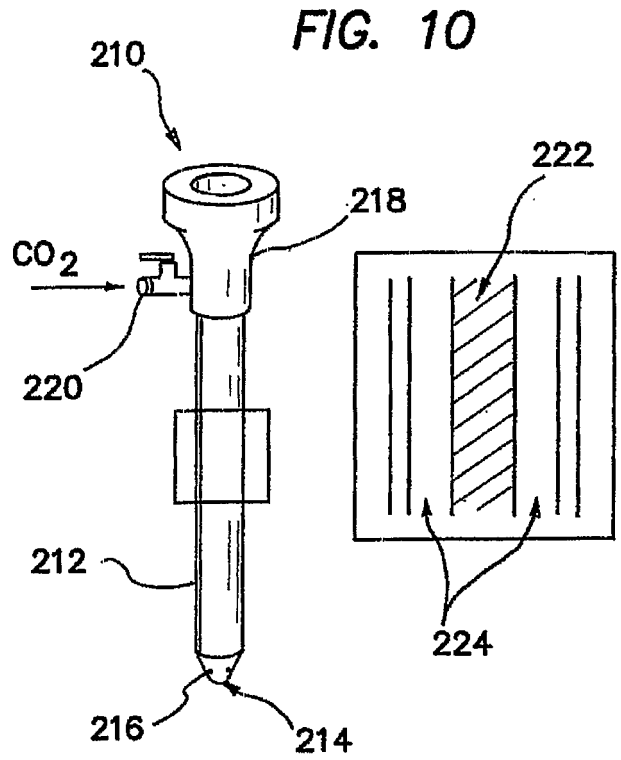
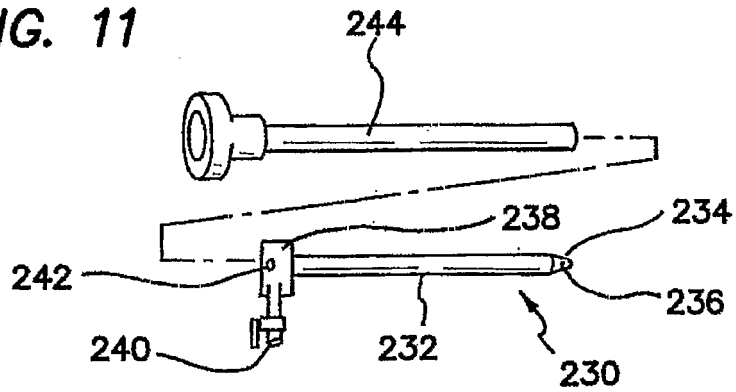

FIG. 10

FIG. 11



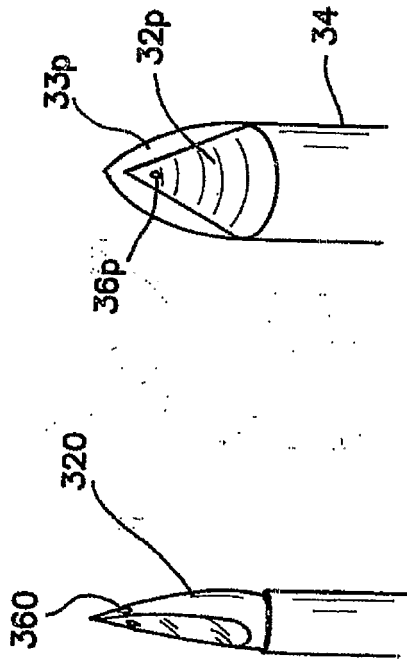

FIG. 12A

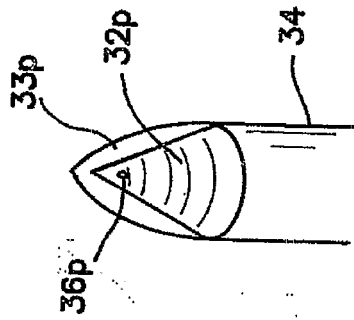

FIG. 12B

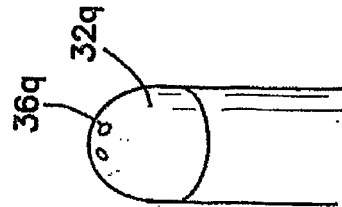

FIG. 12C

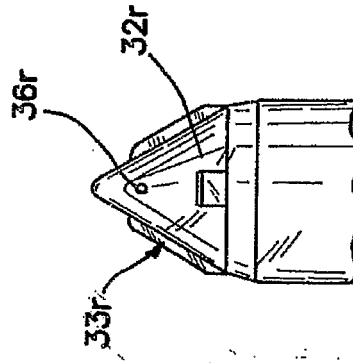

FIG. 12D

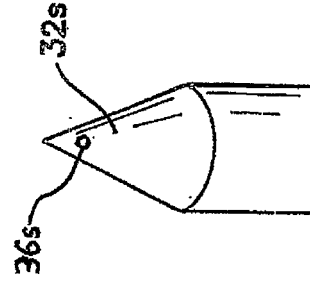
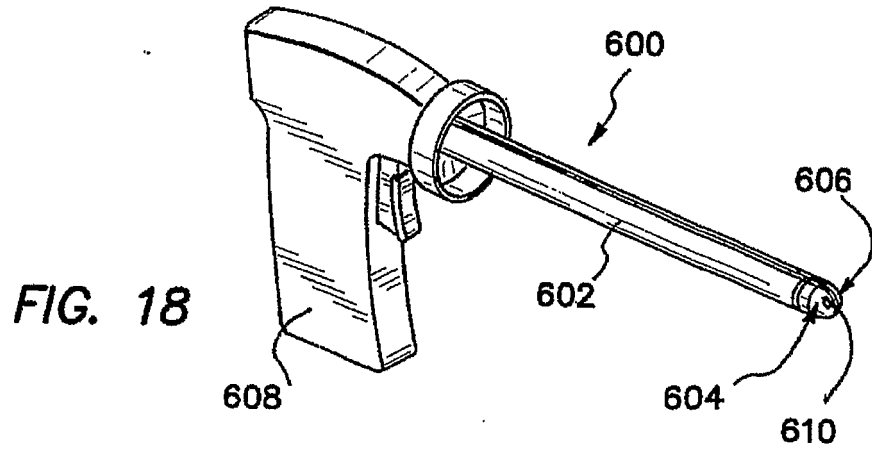
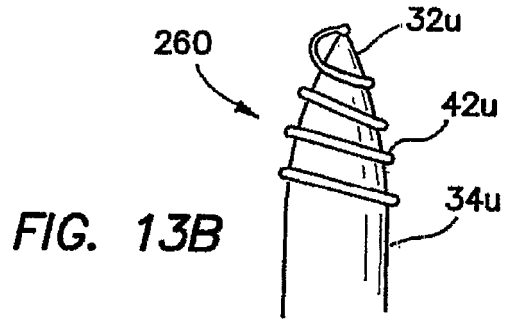
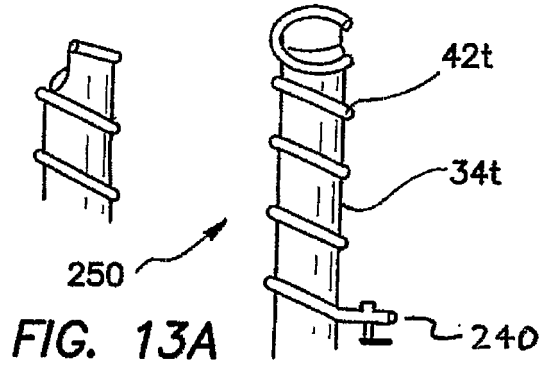

FIG. 12E



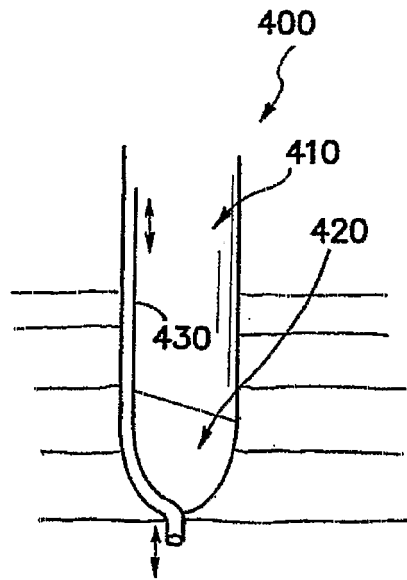

FIG. 16

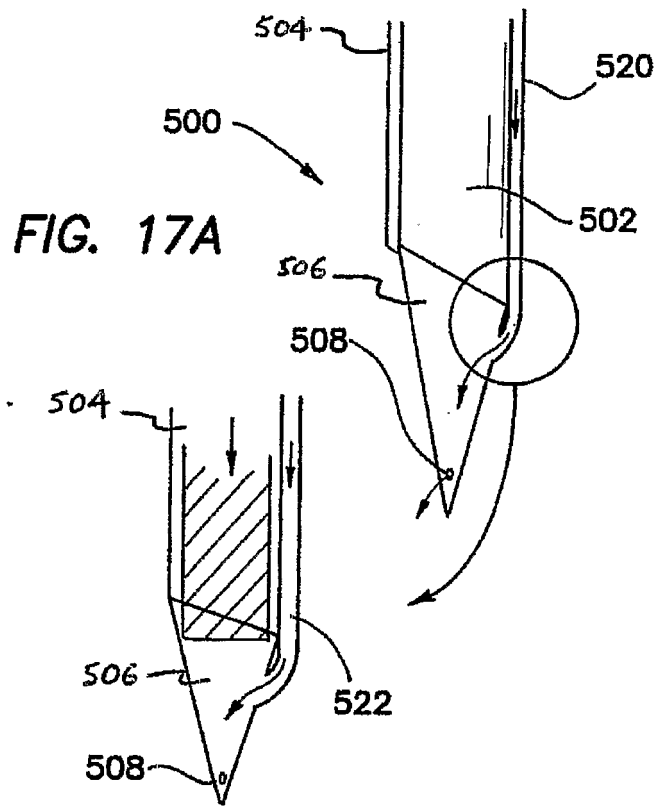
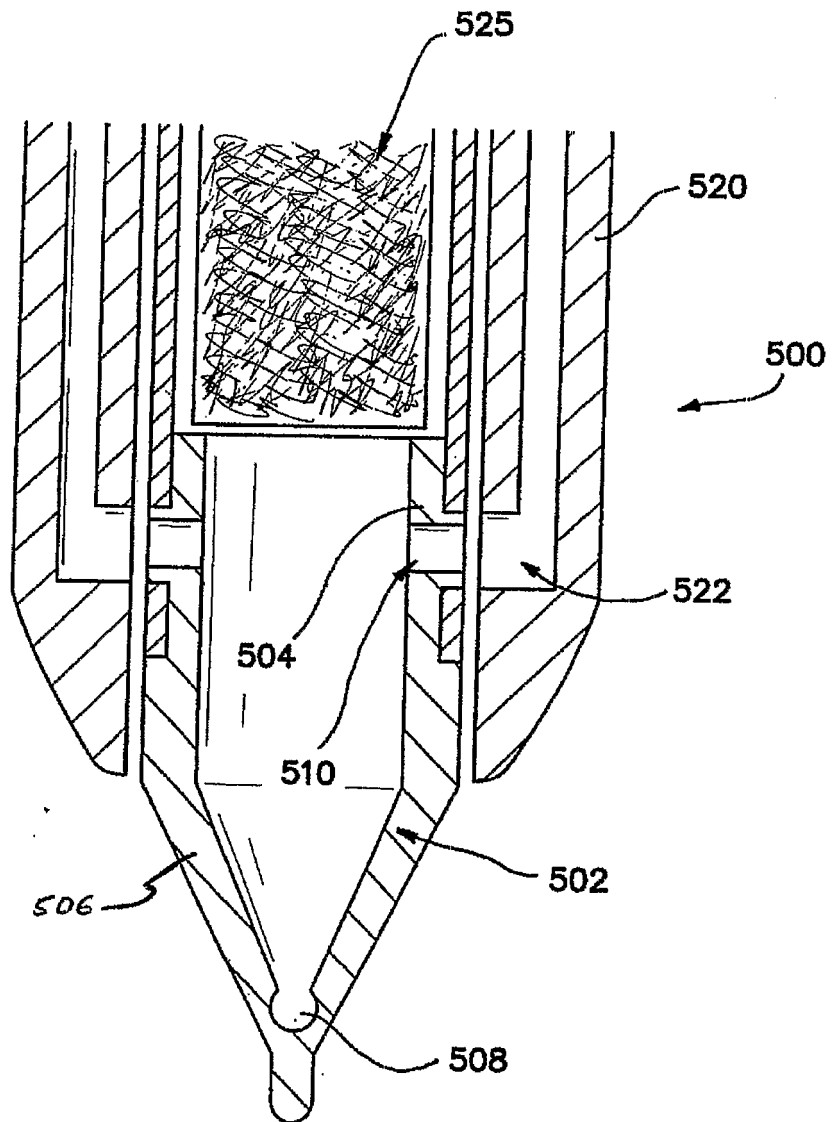

FIG. 17A

FIG. 17B



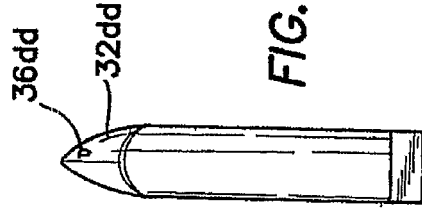

FIG. 19A

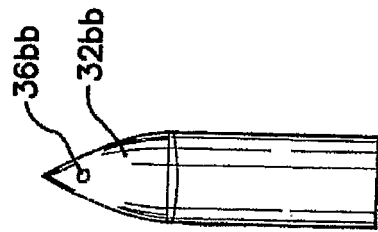

FIG. 19B

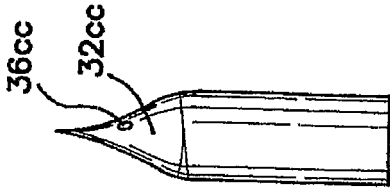

FIG. 19C

FIG. 19D

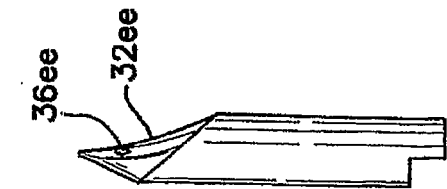

FIG. 19E

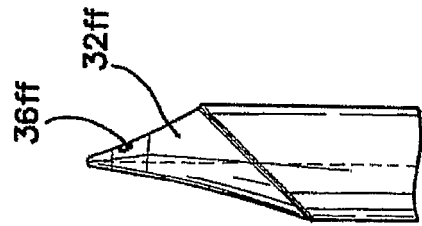

FIG. 19F

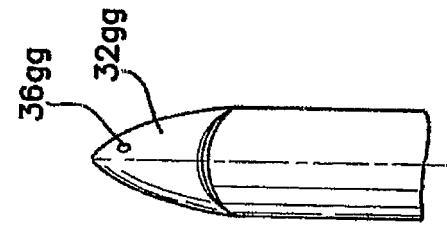

FIG. 19G

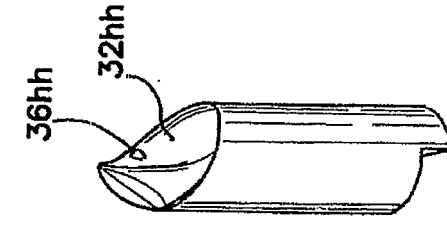

FIG. 19H

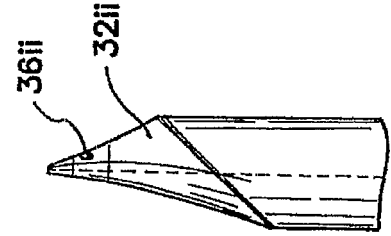

FIG. 19I

INTERNATIONAL SEARCH REPORT

International Application No
PCT/US2005/022716A. CLASSIFICATION OF SUBJECT MATTER
IPC 7 A61B17/34

According to International Patent Classification (IPC) or to both national classification and IPC

B. FIELDS SEARCHED

Minimum documentation searched (classification system followed by classification symbols)
IPC 7 A61B

Documentation searched other than minimum documentation to the extent that such documents are included in the fields searched

Electronic data base consulted during the international search (name of data base and, where practical, search terms used)

EPO-Internal

C. DOCUMENTS CONSIDERED TO BE RELEVANT

Category °	Citation of document, with indication, where appropriate, of the relevant passages	Relevant to claim No.
X	US 5 630 805 A (TERNAMIAN ET AL) 20 May 1997 (1997-05-20) the whole document	1-29, 42, 43, 46-55
X	EP 0 724 864 A (ETHICON ENDO-SURGERY, INC) 7 August 1996 (1996-08-07) column 5, line 3 - line 31 column 7, line 22 - line 31 figures 1,2	1-29, 42, 43, 46-55
X	US 5 445 615 A (YOON ET AL) 29 August 1995 (1995-08-29) column 4, line 59 - line 65; figure 1	1-29, 42, 43, 46-55
X	US 2002/183715 A1 (MANTELL ROBERT R ET AL) 5 December 2002 (2002-12-05) paragraph '0050!; figures 4-6,12	1-29, 42, 43, 46-55
	-/--	

 Further documents are listed in the continuation of box C. Patent family members are listed in annex.

° Special categories of cited documents:

- *A* document defining the general state of the art which is not considered to be of particular relevance
- *E* earlier document but published on or after the international filing date
- *L* document which may throw doubts on priority claim(s) or which is cited to establish the publication date of another citation or other special reason (as specified)
- *O* document referring to an oral disclosure, use, exhibition or other means
- *P* document published prior to the international filing date but later than the priority date claimed

- *T* later document published after the international filing date or priority date and not in conflict with the application but cited to understand the principle or theory underlying the invention
- *X* document of particular relevance; the claimed invention cannot be considered novel or cannot be considered to involve an inventive step when the document is taken alone
- *Y* document of particular relevance; the claimed invention cannot be considered to involve an inventive step when the document is combined with one or more other such documents, such combination being obvious to a person skilled in the art.
- * & * document member of the same patent family

Date of the actual completion of the international search

10 November 2005

Date of mailing of the international search report

22. 11. 2005

Name and mailing address of the ISA

European Patent Office, P.B. 5818 Patentlaan 2
NL - 2280 HV Rijswijk
Tel. (+31-70) 340-2040, Tx. 31 651 epo nl,
Fax: (+31-70) 340-3016

Authorized officer

Borowski, A

INTERNATIONAL SEARCH REPORT

 International Application No
 PCT/US2005/022716

C.(Continuation) DOCUMENTS CONSIDERED TO BE RELEVANT		
Category °	Citation of document, with indication, where appropriate, of the relevant passages	Relevant to claim No.
X	US 2003/023201 A1 (ABOUL-HOSN WALID ET AL) 30 January 2003 (2003-01-30) paragraphs '0009!, '0018!, '0021!; figures 1-3 -----	1-32,42, 43,46-55
X	EP 0 474 124 A (ETHICON INC) 11 March 1992 (1992-03-11) the whole document -----	30
A	WO 01/08563 A (GAYA LIMITED; CALDWELL, MARTIN; CUMMINS, CHRISTOPHER) 8 February 2001 (2001-02-08) the whole document -----	30
A	US 5 752 970 A (YOON ET AL) 19 May 1998 (1998-05-19) the whole document -----	30
A	US 5 797 888 A (YOON ET AL) 25 August 1998 (1998-08-25) the whole document -----	30
A	US 6 228 063 B1 (ABOUL-HOSN WALID NAGIB) 8 May 2001 (2001-05-08) the whole document -----	30

INTERNATIONAL SEARCH REPORT

International application No.
PCT/US2005/022716

Box II Observations where certain claims were found unsearchable (Continuation of item 2 of first sheet)

This International Search Report has not been established in respect of certain claims under Article 17(2)(a) for the following reasons:

1. Claims Nos.: 44, 45
because they relate to subject matter not required to be searched by this Authority, namely:
Rule 39.1(iv) PCT - Method for treatment of the human or animal body by surgery: a method for using an insufflating surgical instrument to create access across an abdominal cavity and to insufflate an abdominal region of a patient.
2. Claims Nos.:
because they relate to parts of the International Application that do not comply with the prescribed requirements to such an extent that no meaningful International Search can be carried out, specifically:
3. Claims Nos.:
because they are dependent claims and are not drafted in accordance with the second and third sentences of Rule 6.4(a).

Box III Observations where unity of invention is lacking (Continuation of item 3 of first sheet)

This International Searching Authority found multiple inventions in this international application, as follows:

see additional sheet

1. As all required additional search fees were timely paid by the applicant, this International Search Report covers all searchable claims.
2. As all searchable claims could be searched without effort justifying an additional fee, this Authority did not invite payment of any additional fee.
3. As only some of the required additional search fees were timely paid by the applicant, this International Search Report covers only those claims for which fees were paid, specifically claims Nos.:
1-38, 42, 43, 46-55
4. No required additional search fees were timely paid by the applicant. Consequently, this International Search Report is restricted to the invention first mentioned in the claims; it is covered by claims Nos.:

Remark on Protest

The additional search fees were accompanied by the applicant's protest.

No protest accompanied the payment of additional search fees.

FURTHER INFORMATION CONTINUED FROM PCT/ISA/ 210

This International Searching Authority found multiple (groups of) inventions in this international application, as follows:

1. claims: 1-29,42-43,46-55

Claims 1-29,42-43,46-55 essentially define an insufflating surgical instrument having a tip at the distal end and at least one vent hole at the tip or along the shaft.

2. claims: 30-38

Claims 30-38 essentially define an insufflating surgical instrument having a tip at the distal end, the tip adapted to be in a closed or in an opened position.

3. claims: 39-41

Claims 39-41 essentially define a laparoscopic insufflating surgical instrument having an optical element disposed at the distal end.

INTERNATIONAL SEARCH REPORT

Information on patent family members

International Application No

PCT/US2005/022716

Patent document cited in search report		Publication date	Patent family member(s)	Publication date
US 5630805	A	20-05-1997	AT 228801 T	15-12-2002
			AU 2417395 A	29-11-1995
			CA 2166627 A1	16-11-1995
			DE 69529048 D1	16-01-2003
			DE 69529048 T2	04-09-2003
			DE 707456 T1	29-08-1996
			EP 0707456 A1	24-04-1996
			WO 9530378 A1	16-11-1995
			JP 3545411 B2	21-07-2004
			JP 9503953 T	22-04-1997
			US 5478329 A	26-12-1995
ZA 9503643 A	27-02-1996			
EP 0724864	A	07-08-1996	AU 696687 B2	17-09-1998
			AU 4229596 A	08-08-1996
			CA 2168414 A1	02-08-1996
			DE 69602111 D1	27-05-1999
			DE 69602111 T2	19-08-1999
			ES 2130747 T3	01-07-1999
			JP 8266548 A	15-10-1996
			US 5569292 A	29-10-1996
US 5445615	A	29-08-1995	AT 175852 T	15-02-1999
			CA 2122817 A1	13-05-1993
			DE 69228257 D1	04-03-1999
			DE 69228257 T2	08-07-1999
			EP 0615421 A1	21-09-1994
			ES 2126604 T3	01-04-1999
			JP 7500758 T	26-01-1995
			WO 9308729 A1	13-05-1993
US 2002183715	A1	05-12-2002	CA 2444303 A1	31-10-2002
			EP 1381421 A1	21-01-2004
			WO 02085444 A1	31-10-2002
US 2003023201	A1	30-01-2003	US 2005020968 A1	27-01-2005
EP 0474124	A	11-03-1992	AU 8275491 A	05-03-1992
			CA 2050117 A1	01-03-1992
			GR 91100355 A	31-08-1992
			IE 913055 A1	11-03-1992
			JP 4253852 A	09-09-1992
			US 5114407 A	19-05-1992
			ZA 9106863 A	01-03-1993
			WO 0108563	A
IE 990659 A2	21-02-2001			
US 5752970	A	19-05-1998	AU 4763296 A	21-08-1996
			WO 9623536 A1	08-08-1996
US 5797888	A	25-08-1998	AU 2202297 A	10-10-1997
			WO 9734650 A1	25-09-1997
			US 5814026 A	29-09-1998
			US 5989232 A	23-11-1999
			US 5913847 A	22-06-1999
			US 5989233 A	23-11-1999

INTERNATIONAL SEARCH REPORT

Information on patent family members

International Application No

PCT/US2005/022716

Patent document cited in search report	Publication date	Patent family member(s)	Publication date
US 6228063	B1 08-05-2001	US 5741234 A	21-04-1998

专利名称(译)	充气光学手术器械		
公开(公告)号	EP1765197A1	公开(公告)日	2007-03-28
申请号	EP2005767670	申请日	2005-06-28
[标]申请(专利权)人(译)	应用医疗资源		
申请(专利权)人(译)	应用医疗资源		
当前申请(专利权)人(译)	应用医疗资源CORPORATION		
[标]发明人	ALBRECHT JEREMY J BRUSTAD JOHN R TAYLOR SCOTT V JOHNSON GARY M HILAL NABIL		
发明人	ALBRECHT, JEREMY J. BRUSTAD, JOHN R. TAYLOR, SCOTT V. JOHNSON, GARY M. HILAL, NABIL		
IPC分类号	A61B17/34 A61B19/00		
CPC分类号	A61M13/003 A61B1/06 A61B17/3417 A61B17/3462 A61B17/3474 A61B17/3494 A61B90/361 A61B2017/3454 A61B2017/346 A61B2017/349 A61M2202/0007 A61M2202/02 A61M2202/0468 A61M2205/3337		
优先权	10/956167 2004-10-01 US 60/584302 2004-06-29 US		
其他公开文献	EP1765197B1		
外部链接	Espacenet		

摘要(译)

一种吹气手术器械，适于穿过腹壁移动以吹入患者的腹部区域。该器械包括轴，该轴具有沿近端和远端之间的轴线延伸的吹入，吹入通道适于连接到近端压力下的流体源，轴的远端处的尖端，在所述尖端处或所述轴处形成的至少一个通气孔与所述吹气通道连接并且适于在压力下排出所述流体以吹入所述腹部区域。尖端和轴中的至少一个由诸如聚碳酸酯的半透明或透明材料形成，以便于腹壁和腹部区域的可视化。