



(11) **EP 3 195 811 A1**

(12) **EUROPEAN PATENT APPLICATION**

(43) Date of publication:
26.07.2017 Bulletin 2017/30

(51) Int Cl.:
A61B 17/064 ^(2006.01) **A61B 17/068** ^(2006.01)
A61B 17/00 ^(2006.01)

(21) Application number: **16168443.6**

(22) Date of filing: **04.05.2016**

(84) Designated Contracting States:
AL AT BE BG CH CY CZ DE DK EE ES FI FR GB GR HR HU IE IS IT LI LT LU LV MC MK MT NL NO PL PT RO RS SE SI SK SM TR
Designated Extension States:
BA ME
Designated Validation States:
MA MD

(72) Inventors:
• **SUN, Jie**
100027 Beijing (CN)
• **QIAO, Hongjiu**
100027 Beijing (CN)
• **CHEN, Fan**
100027 Beijing (CN)
• **DING, Lingcui**
100027 Beijing (CN)
• **MENG, Kai**
100027 Beijing (CN)

(30) Priority: **25.01.2016 CN 201610051820**
25.01.2016 CN 201620072770 U
25.01.2016 CN 201610051764
25.01.2016 CN 201620073762 U
25.01.2016 CN 201610051818
25.01.2016 CN 201610051765

(74) Representative: **Rapisardi, Mariacristina**
Ufficio Brevetti Rapisardi S.r.l.
Via Serbelloni, 12
20122 Milano (IT)

(71) Applicant: **TransEasy Medical Tech. Co., Ltd.**
100027 Beijing (CN)

(54) **FIXING DEVICE FOR SOFT TISSUE**

(57) The present invention relates to the field of medical equipment's technology, and more particularly to a fixing device for soft tissue with an absorbable screw or titanium screw. The fixing device for soft tissue includes a driving device, screw tube and a drive rod. A catheter is arranged around the screw tube by screw thread, and a plurality of absorbable screws or titanium screws are arranged in the catheter. A screw thread structure is formed on a nailed beam of each of the absorbable screws, and a lead spring is arranged on each of the absorbable screws structure. The plurality of absorbable screws or titanium screws are connected in series in the form of head to tail connection and put into the catheter

with a spiral groove. The driving rod is driven to rotate by the driving device in use under pulling the trigger; further the absorbable screw or titanium screw can be shot out of the catheter one by one when the laparoscopic hernia repair is performing. The fixing device for soft tissue with the absorbable screw or titanium of the present invention is particularly suitable for laparoscopic hernia repair operations. Furthermore, the fixing device for soft tissue of the present invention has characteristics of anti-adhesion, convenient and reliable operation, and the catheter is a detachable replacement element, so the fixing device can be reused after the catheter is replaced

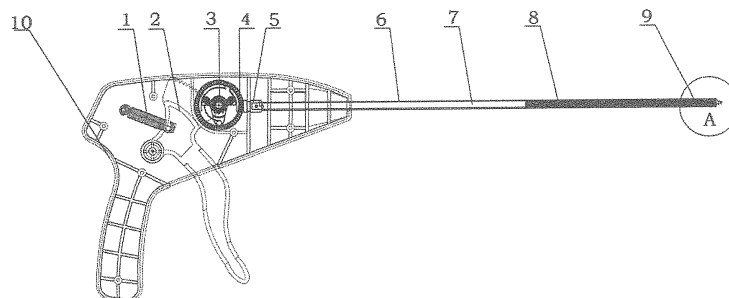

Fig.1

EP 3 195 811 A1

Description**FIELD OF THE INVENTION**

[0001] The present invention relates to the field of medical equipment's technology, and more particularly to a fixing device for soft tissue with an absorbable screw or titanium screw.

BACKGROUND OF THE INVENTION

[0002] Incisional hernia, which refers to a type of hernia that abdominal viscera or tissue protrudes from abdominal incision, is a common complication in laparotomy. The incision along a middle line of a lower portion of the abdomen has a high incidence of incisional hernia. The incisional hernia mostly occurs on longitudinal incision sites of the abdomen including incision dehiscence, incision infection and a secondary incision healing. A minority of the incisional hernia appears a long time after operation on the ones without incision dehiscence history. A morbidity of the incisional hernia is in the range of 2-11%, and an infected incision has an incisional hernia of up to about 40%. The incisional hernia on an abdominal wall is mainly treated by operation. Currently, the conventional repair method for the incisional hernia includes an open style hernia plastic operation with or without an artificial patch and a laparoscopic insional hernia repair operation. A recurrence rate of the incisional hernia after making a simple tissue suture repair operation is still up to 20-50%. According to a principle of incisional hernia classification in China, a medium-large or even huge scale of incisional hernia is more common in clinical trials. These types of incisional hernia are mainly performed with tension-free hernioplasty by the means of the artificial patch, which is capable of reducing effectively the recurrence rate of the incisional hernia to about 10%. Compared with open style hernia plastic operations, the laparoscopic insional hernia repair has characteristics as follows.

(1) The laparoscopic incisional hernia repair follows the principle of abdominal wall hernia surgery, and is in line with the theory of biological engineering mechanics of repairing for strengthening the rear wall, and the recurrence rate after the operation can reach 5%.

(2) The surgical approach is far away from the original incision hernia, so as to reduce the infection chance on implant sites of material, which is particularly suitable for the wound infection persons.

(3) A wide range of the abdominal tissue is not damaged to be free, and the original strength of the abdominal wall is retained as much as possible, which is more suitable for recurrent incisional hernia.

(4) Soft tissue capable of supplying blood is retained between skin on the hernia defect site and the artificial patch, and the soft tissue is capable of effectively cover and oppress the artificial patch, which is capable of facilitating the fibrous tissue to grow into an aperture of polypropylene mesh, so as to improve the tension strength between the artificial patch and the abdominal wall.

(5) Contents of free hernia in the pneumoperitoneum are more intuitively clear, and the force of gravity causes the contents of the hernia drooped naturally, so as to avoid the passive situation of intestinal injuries.

(6) An occult "pinhole hernia" is easier to find, so as to reduce the recurrence of abdominal hernia after operation caused thereby.

(7) Multi-point fixed patch is sutured and screwed in the abdominal cavity to reduce the uniformly dispersed tension.

(8) The area implanting the patch does has no skin incisions, so as to reduce the possibility of hematoma and liquid and replacement of a conventional drainage tube is not needed, so as to reduce the chance of contamination.

(9) The patch is fixed by non-abdominal wall penetration, so the postoperative pain is light, the duration of the operation is short and the patient recovers quickly.

(10) The laparoscopic operation is capable of not only reducing incisional infection, reducing postoperative recurrent rate but also achieving minimally invasive effects.

(11) The laparoscopic operation is technical demanding and requires a relative long learning time.

[0003] Based on the characteristics mentioned above, laparoscopic incisional hernia repair gradually attracts people's concern in recent years, and becomes more and more popular in the treatment of incisional hernia. The method for fixing patch in the laparoscopic hernia repair comprises completely suturing, completely nailing, combination of suturing, nailing and adhesive, and there is no uniform standard currently.

[0004] In the prior art, a speculum stapling device and a disposable screw case is disclosed in a patent application No. 200810009395.6, TYCO healthcare group. An absorbable screw nail for fixing hernia repair patch is disclosed in US 2007/0038220 A1, John Isbell Shipp, where the absorbable screw nail is made of a copolymer of lactide and glycolide. A surgical operation fixing method and device is disclosed in US 2007/0250064 A1, Da-

vol, Inc., Cranston, RI. An I-shaped operation fixing device is disclosed in US 2003/0187465 A1, SOFRADIM PRODUCTION, Trevoux (FR). And a surgical spiral fixing device is disclosed in US5366479A, Origin Medsystems, Inc. Menlo park, Calif. The fixing device mentioned above solves the problems of time-consuming and inconvenient during the process of repairing suture, and furthermore, hemorrhage and trauma of the patient is decreased. The conventional surgical fixing device is in a type of a staple. Deformation fixed by the staple type fixing device needs other components such as an iron felt, and thus the structure is very complicated and the cost is high. A far-end of the one way screw nail has a penetrating point, and a near-end thereof has a T-shaped bar, wherein the T-shaped bar equally divides a diameter of the screw nail and provides a stress face. According to another embodiment, the screw nail is a double-sided screw, a far-end of the double-sided screw nail has two penetrating points and a near-end thereof has a connecting bar, wherein the connecting bar connects two spiral coils and equally divides diameters of the two spiral coils. In the prior art, the fixing device is generally a disposable product and may cause friction tissue injury on the human body during operation process.

SUMMARY OF THE PRESENT INVENTION

[0005] In order to solve the technical problems in the prior art, the present invention provides a fixing device for soft tissue with an absorbable screw or titanium screw.

[0006] Accordingly, in order to achieve the objects mentioned above, the present invention adopts technical solutions as follows:

[0007] A fixing device for soft tissue includes: a handle, a tension spring, a trigger, a driving gear, a big helical gear, a small helical gear, a screw tube and a driving rod. A first end of the tension spring is mounted on a fixing post on an internal wall of the handle; a second end of the tension spring is arranged on an upper end of the trigger. One side of the upper end of the trigger is rotatably connected to the internal wall of the handle via a rotation axis, a helical gear matching with the driving gear is arranged on the other side of the upper end of the trigger. The trigger extends outward from an inside of the handle and its lower end is located in the outside of the handle. The big helical gear and the driving gear are arranged concentrically, and the big helical gear is driven by the driving gear, outer teeth of the big helical gear match with outer teeth of the small helical gear. The driving rod is driven by a rotation axis of the small helical gear, the screw tube is arranged around the driving rod, a first end of the screw tube is arranged inside of the handle, and a second end of the screw tube is arranged outside of the handle, a catheter is removably connected on the second end of the screw pipe, and an absorbable screw or titanium screw is arranged inside of the catheter, a screw thread structure is arranged on a nailed beam of the absorbable screw, and a lead spring is provided

on the screw thread structure.

[0008] In the present invention, a lubricant coating is covered on the catheter, which is beneficial to put the catheter having the fixing device for the soft tissue with the absorbable screw or titanium screw into human tissue smoothly, so as to prevent adhesion. In the prior art, the lubricant coating or an anti-adhesion coating may be for example silicon oil, such as dimethyl siloxane and the like. In the present invention, the lubricant coating containing Teflon is covered on the catheter, and a thickness of the lubricant coating is in the range of 3-5 μ m. A surface hardness of a lubricant compatible coating is in the range of Hv500-Hv1000, and a surface friction coefficient is in the range of 0.1-0.05. The lubricant coating further includes stable polymers selecting from a group consisting of one or more of the following: polymethyl methacrylate, polyacrylamide, polyacrylonitrile, polyether amide, polyethylenediamine, polycarbonate, polyketene, polyvinyl ether, polyvinyl ester, polyvinylpyrrolidone, polyethylene, polypropylene, polytetrafluoroethylene, polyolefin elastomer, polyisobutene, fluorosilicone, carboxymethyl chitosan, polyethylene terephthalate, poly-pentanoate, carboxymethyl cellulose, hydroxyethylcellulose, cellulose butyrate, cellulose acetate butyrate, ethyl-vinyl acetate copolymer, chitosan and chitosan derivatives. Preferably, the lubricant coating further comprises antibacterial agent, the antibacterial agent can be a silver based antibacterial agent or a non-silver based antibacterial agent. For example, the silver based antibacterial agent, the silver based antibacterial agent can be silver particles, silver based antibacterial agent or non-silver based antibacterial agent based on glass carriers, or silver based antibacterial agent based on zeolite carrier. The antibacterial agent can be added to a combination by a conventional mixing method and dispersed in a lubricant compatible coating obtained by applying. The antibacterial agent is capable of preventing or inhibiting growth of microorganisms carried, thereby preventing infection caused by fixing operation.

[0009] Preferably, the absorbable screw is made of a degradable material. The degradable material is selected from a group consisting of at least one of the following: poly(L-lactide), poly(D, L-lactide), poly(L-lactide-co-D, L-lactide), poly(D,L-lactide-co-glycolide), poly-glycolide, poly(L-lactide-co-glycolide), poly(glycolide-co-trimethylene carbonate), poly(L-lactide-co-trimethylene carbonate), poly(D,L-lactide-co-trimethylene carbonate), poly(L-lactide-co-caprolactone), poly(amino acids), poly(ϵ -caprolactone), poly(δ -valerolactone), poly(γ -butyrolactone), poly(β -hydroxybutyrate), poly(DL-lactide), poly(L-lactide), ethylene carbonate (1,3-dioxolan-2-one), propylene carbonate (4-methyl-1,3-dioxolan-2-one), 1,3-propylene carbonate (1,3-dioxan-2-one) and tetramethylene carbonate (1,3-dioxacyloheptane-2-one).

[0010] Preferably, the degradable material includes 10-15 wt% of poly(butylenes-co- ϵ -caprolactone carbonate) (PBCL) and 80-90wt% of poly(lactic-co-glycolic acid) (PLGA), the poly(lactic-co-glycolic acid) is synthesized

by PDLA (polylactic acid) and PGA (poly glycolic acid), and a molar ratio of the PLDA to PGA is 40:60. Preferably, the degradable material further includes 1-5wt% of sulfo-N-hydroxy succinimide sodium.

[0011] The titanium screw is formed by helically buckling titanium alloy wire.

[0012] Preferably, the titanium alloy composes of 5.5-6.0wt% of Mo, 1.5-2.0wt% of Zr, 0.3-0.5wt% of Mg, 0.05-0.15wt% of Nb and a remaining amount of Ti. A micro-arc oxidation surface modification treatment for the titanium alloy wire is performed, and an electrolyte solution of the micro-arc oxidation surface modification treatment composes of 1.5-2.0wt% of sodium citrate, 0.10-0.20wt% of sodium borate, 0.05-0.10wt% of glycine and a remaining amount of water, and a voltage of the micro-arc oxidation surface modification treatment is in the range of 200-250V, a current density thereof is in the range of 0.02~0.20 Adm⁻², and a treatment time thereof is in the range of 10-20 min.

[0013] Compared with the prior art, the fixing device for soft tissue with the absorbable screw or titanium of the present invention has beneficial effects as follows.

[0014] The fixing device for soft tissue with the absorbable screw or titanium of the present invention is particularly suitable for laparoscopic hernia repair operations. Furthermore, the fixing device for soft tissue of the present invention has characteristics of anti-adhesion, convenient and reliable operation. In the present invention, the catheter is a detachable replacement element, so the fixing device can be reused after the catheter is replaced.

BRIEF DESCRIPTION OF THE DRAWINGS

[0015]

Fig. 1 is a structural schematic view of a fixing device for soft tissue according to an embodiment of the present invention.

Fig. 2 is an enlarged structure schematic view of an absorbable screw in a circle A in the Fig. 1.

Fig. 3 is an enlarged structure schematic view of a titanium screw in the circle A in the Fig. 1.

DETAILED DESCRIPTION OF THE EMBODIMENTS

[0016] Further description of a fixing device for soft tissue with an absorbable screw is illustrated with respect to embodiments of the present invention. These and other objectives, features, and advantages of the present invention will become apparent from the following detailed description, the accompanying drawings, and the appended claims.

[0017] As shown in Figs. 1-2, according to an embodiment of the present invention, a fixing device for soft tissue with an absorbable screw includes a handle 10, an

tension spring 1, a trigger 2, a driving gear 3, a big helical gear 4, a small helical gear 5, a screw tube 6 and a driving rod 7. A first end of the tension spring 1 is mounted on a fixing post on an internal wall of the handle 10, a second end of the tension spring 1 is arranged on an upper end of the trigger 2. One side of the upper end of the trigger 2 is rotatably connected to the internal wall of the handle 10 via a rotation axis, a helical gear matching with the driving gear 3 is arranged on the other second side of the upper end of the trigger 2. The trigger 2 extends outward from an inside of the handle 10, and its lower end is located in the outside of the handle 10. The big helical gear 4 and the driving gear 3 are arranged concentrically, and the big helical gear 4 is driven by the driving gear 3, outer teeth of the big helical gear 4 match with outer teeth of the small helical gear 5. The driving rod 7 is driven by a rotation axis of the small helical gear 5, the screw tube 6 is arranged around the driving rod 7, a first end of the screw tube 6 is arranged inside of the handle 10, and a second end of the screw tube 6 is arranged outside of the handle 10, a catheter 8 is removably connected on the second end of the screw pipe, and an absorbable screw 9 is arranged inside of the catheter 8, a screw thread structure is arranged on a nailed beam of the absorbable screw 9, and a lead spring is provided on the screw thread structure. Specifically, a plurality of the absorbable screws are connected in series in the form of head to tail connection and put into the catheter with a spiral groove, where the heads of the absorbable screws toward an outlet of the catheter. In the embodiment, the trigger, the tension spring, the driving gear, the big helical gear and the small helical gear form a driving device of the fixing device for the soft tissue of the present invention. The driving rod is driven to rotate by the driving device in use under pulling the trigger, further the absorbable screw or titanium screw can be shot out of the catheter one by one when the laparoscopic hernia repair is performing.

[0018] In the present invention, a lubricant coating is covered on the catheter, which is beneficial to put the catheter having the fixing device for the soft tissue with the absorbable screw or titanium screw into human tissue smoothly, so as to prevent adhesion. In the prior art, the lubricant coating or an anti-adhesion coating may be for example silicon oil, such as dimethyl siloxane and the like. In the present invention, the lubricant coating containing Teflon is covered on the catheter, and a thickness of the lubricant coating is in the range of 3-5 μ m. A surface hardness of the lubricant coating is in the range of 3-5 μ m. A surface hardness of a lubricant compatible coating is in the range of Hv500-Hv1000, and a surface friction coefficient is in the range of 0.1-0.05. The lubricant coating further includes stable polymers selecting from a group consisting of one or more of the following: polymethyl methacrylate, polyacrylamide, polyacrylonitrile, polyether amide, poly-ethylenediamine, polycarbonate, polyketene, polyvinyl ether, polyvinyl ester, polyvinylpyrrolidone, polyethylene, polypropylene, polytetrafluor-

oethylene, polyolefin elastomer, polyisobutene, fluorosilicone, carboxymethyl chitosan, polyethylene terephthalate, poly-pentanoate, carboxymethyl cellulose, hydroxyethylcellulose, cellulose butyrate, cellulose acetate butyrate, ethyl-vinylacetate copolymer, chitosan and chitosan derivatives. Preferably, the lubricant coating contains 0.01-1.5wt% of antibacterial agent, the antibacterial agent can be silver based antibacterial agent or non-silver based antibacterial agent. For example, the silver based antibacterial agent, the silver based antibacterial agent can be silver particles, silver based antibacterial agent or non-silver based antibacterial agent based on glass carriers, or silver based antibacterial agent based on zeolite carrier. The antibacterial agent can be added to a combination by a conventional mixing method and dispersed in alubricant compatible coatingobtained by applying. The antibacterial agent is capable of preventing or inhibiting growth of microorganisms carried, thereby preventing infection caused by fixing operation.

Embodiment 1

[0019] In the present invention, the absorbable screw is made of a degradable material. As an example, the degradable material is selected from a group consisting of at least one of the following: poly(L-lactide), poly(D, L-lactide), poly(L-lactide-co-D, L-lactide), poly(D,L-lactide-co-glycolide), poly-glycolide, poly(L-lactide-co-glycolide), poly(glycolide-co-trimethylene carbonate), poly(L-lactide-co-trimethylene carbonate), poly(D,L-lactide-co-trimethylene carbonate), poly(L-lactide-co-caprolactone), poly (amino acids), poly (ϵ -caprolactone), poly (δ -valerolactone), poly (γ -butyrolactone), poly (β -hydroxybutyrate), poly(DL-lactide), poly(L-lactide), ethylene carbonate (1,3-dioxolan-2-one), propylene carbonate (4-methyl-1,3-dioxolan-2-one), 1,3-propylene carbonate (1,3-dioxan-2-one) and tetramethylene carbonate (1,3-dioxacyloheptane-2-one).

[0020] As an improvement, the degradable material includes 10-15 wt% of poly(butylenes-co- ϵ -caprolactone carbonate) (PBCL) and 80-90wt% of poly(lactic-co-glycolic acid) (PLGA), the poly(lactic-co-glycolic acid) is synthesized by PDLA (foscolic acid) and PGA (poly glycolic acid), where a molar ratio of the PDLA to the PGA is 40:60. Preferably, the degradable material further includes 1-5wt% of sulfo-N-hydroxy succinimide sodium. The static degradation testing based on Hanks' balanced salt solution indicates that: adding PBCL is capable of stabilizing a time which makes the have a weight loss of 90% within 80-90 days. Thus the degradable materials have excellent degradation performance, small stimulation and excellent compatibility. In addition, adding sulfo-N-hydroxy succinimide sodium is capable of facilitating hernia coalescence.

[0021] In the present invention, the absorbable screw is obtained by processes of raw material mixing, melt extruding and machining. As an example, raw material combination of the degradable materials is sent into a

blender mixer to be evenly mixed, where a mixing temperature is controlled below 80°C. Mixed materials are cooled and then melt extruded by a single-screw extruder. Temperature on each section of the single-screw extruder is in the range of 150~210°C. Melt blending materials obtained are processed into a round bar after being extruded. A mechanic performance testing shows that a tensile strength of the round bar is capable of reaching 50-60MPa, and a bending strength thereof is capable of reaching 100-120MPa. The stretched round bar is cut into sections by certain length, and then is performed with lathe processing according to screw thread parameters and screw structures, the absorbable screw is obtained. In the present invention, the absorbable screw adopts a shape of the conventional screw in the prior art, e.g., a front half of the whole body is a cone shape, and a back half thereof is a post shape, or the whole body is a circular truncated cone, such that the absorbable screw can be positioned accurately by a guide pin in the operation. Parameters of the screw thread are not limited, and a deep and flattened thread is preferred.

Embodiment 2

[0022] In the present invention, the titanium screw is formed by helically buckling titanium alloy wire. The titanium alloy composes of 5.5-6.0wt% of Mo, 1.5-2.0wt% of Zr, 0.3-0.5wt% of Mg, 0.05-0.15wt% of Nb and a remaining amount of Ti. In the present invention, by solution treatment, extension strength of the titanium alloy can reach 820-900MPa, yield strength can reach 800-850MPa, an elongation ratio can reach 25-35% and a fracture toughness can reach 85-90 MPam^{-1/2}, and thus malleability and toughness of the titanium alloy is good. During machining process, a micro-arc oxidation surface modification treatment for the titanium alloy wire is performed, and an electrolyte solution of the micro-arc oxidation surface modification treatment composes of 1.5-2.0wt% of sodium citrate, 0.10-0.20wt% of sodium borate, 0.05-0.10wt% of glycine and a remaining amount of water. After the modification treatment, in the alloy wire, which is added with an appropriate amount of Mg and Zr and in a Hank's solution, its anodizing curve can maintain in a stable passive state at a voltage of 0.5-2.5V, and a dissolution quantity of metallic ion is small (100ppmcm⁻² below), thereby significantly improving corrosion resistance and biocompatibility of the titanium screw. Specifically, a voltage of the micro-arc oxidation treatment is in the range of 200-250V and a current density thereof is in the range of 0.02-0.20 Adm⁻², and treatment time is in the range of 10-20 min.

[0023] One skilled in the art will understand that the embodiment of the present invention as shown in the drawings and described above is exemplary only and not intended to be limiting. It will thus be seen that the objects of the present invention have been fully and effectively accomplished. Its embodiments have been shown and described for the purposes of illustrating the functional

and structural principles of the present invention and is subject to change without departure from such principles. Therefore, this invention includes all modifications encompassed within the spirit and scope of the following claims.

Claims

1. A fixing device for soft tissue, comprising: a handle, an tension spring, a trigger, a driving gear, a big helical gear, a small helical gear, a screw tube and a driving rod, wherein a first end of the tension spring is mounted on a fixing post on an internal wall of the handle, a second end of the tension spring is arranged on an upper end of the trigger, one side of the upper end of the trigger is rotatably connected to the internal wall of the handle via a rotation axis; a helical gear matching with the driving gear is arranged on the other side of the upper end of the trigger, the trigger extends outward from an inside of the handle and its lower end located in the outside of the handle, the big helical gear and the driving gear are arranged concentrically, and the big helical gear is driven by the driving gear, outer teeth of the big helical gear match with outer teeth of the small helical gear; the driving rod is driven by a rotation axis of the small helical gear, the screw tube is arranged around the driving rod, a first end of the screw tube is arranged inside of the handle, and a second end of the screw tube is arranged outside of the handle, a catheter is removably connected on the second end of the screw pipe, and an absorbable screw or titanium screw is arranged inside of the catheter, a screw thread structure is formed on a nailed beam of the absorbable screw, and a lead spring is arranged on the screw thread structure.
2. The fixing device for soft tissue of claim 1, wherein a lubricant coating containing Teflon is covered on the catheter, and a thickness of the lubricant coating is in the range of 3-5 μ m.
3. The fixing device for soft tissue of claim 2, wherein a surface hardness of the lubricant coating is in the range of Hv500-Hv1000, and a its surface friction coefficient is in the range of 0.1-0.05.
4. The fixing device for soft tissue of claim 2, wherein the lubricant coating further comprises stable polymers selecting from a group consisting of one or more of the following: polymethyl methacrylate, polyacrylamide, polyacrylonitrile, polyether amide, polyethylenediamine, polycarbonate, polyketene, polyvinyl ether, polyvinyl ester, polyvinylpyrrolidone, polyethylene, polypropylene, polytetrafluoroethylene, polyolefin elastomer, polyisobutene, fluorosilicone, carboxymethyl chitosan, polyethylene terephthalate, poly-pentanoate, carboxymethyl cellulose, hydroxyethylcellulose, cellulose butyrate, cellulose acetate butyrate, ethyl-vinylacetate copolymer, chitosan and chitosan derivatives.
5. The fixing device for soft tissue of claim 2, wherein the lubricant coating further comprises antibacterial agent.
6. The fixing device for soft tissue of claim 1, wherein the absorbable screw is made of degradable material.
7. The fixing device for soft tissue of claim 6, wherein the degradable material is selected from a group consisting of at least one of the following: poly(L-lactide), poly(D, L-lactide), poly(L-lactide-co-D, L-lactide), poly(D,L-lactide-co-glycolide), poly-glycolide, poly(L-lactide-co-glycolide), poly(glycolide-co-trimethylene carbonate), poly(L-lactide-co-trimethylene carbonate), poly(D,L-lactide-co-trimethylene carbonate), poly(L-lactide-co-caprolactone), poly(amino acids), poly(ϵ -caprolactone), poly(δ -valerolactone), poly(γ -butyrolactone), poly(β -hydroxybutyrate), poly(DL-lactide), poly(L-lactide), ethylene carbonate (1,3-dioxolan-2-one), propylene carbonate (4-methyl-1,3-dioxolan-2-one), 1,3-propylene carbonate (1,3-dioxan-2-one) and tetramethylene carbonate (1,3-dioxacyloheptane-2-one).
8. The fixing device for soft tissue of claim 6, wherein the degradable material comprises 10-15 wt% of poly(butylenes-co- ϵ -caprolactone carbonate) (PBCL) and 80-90wt% of poly(lactic-co-glycolic acid) (PLGA), the poly(lactic-co-glycolic acid) is synthesized by PDLA (foscolic acid) and PGA (poly glycolic acid) and a molar ratio of the PLDA to PGA is 40:60.
9. The fixing device for soft tissue of claim 8, wherein the degradable material further comprises 1-5wt% of sulfo-N-hydroxy succinimide sodium.
10. The fixing device for soft tissue of claim 1, wherein the titanium screw is formed by helically buckling a titanium alloy wire.
11. The fixing device for soft tissue of claim 10, wherein the titanium alloy composes of 5.5-6.0wt% of Mo, 1.5-2.0wt% of Zr, 0.3-0.5wt% of Mg, 0.05-0.15wt% of Nb and a remaining amount of Ti.
12. The fixing device for soft tissue of claim 10, wherein a micro-arc oxidation surface modification treatment for the titanium alloy wire is performed, and an electrolyte of the micro-arc oxidation surface modification treatment, and an electrolyte solution of the micro-arc oxidation surface modification treatment composes of 1.5-2.0wt% of sodium citrate,

0.10-0.20wt% of sodium borate, 0.05-0.10wt% of glycine and a remaining amount of water, wherein a voltage of the micro-arc oxidation surface modification treatment is in the range of 200-250V and its current density is in the range of 0.02-0.20 Adm⁻², and its treatment time is in the range of 10-20 min.

5

10

15

20

25

30

35

40

45

50

55

7

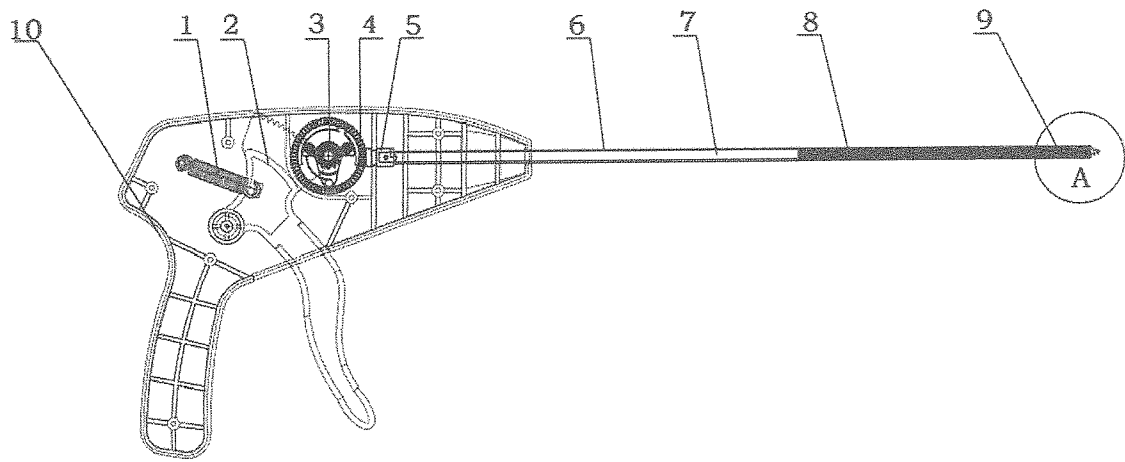

Fig.1

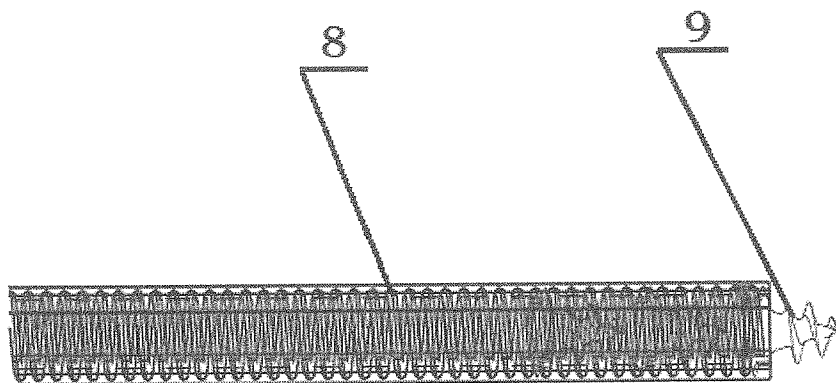

Fig.2

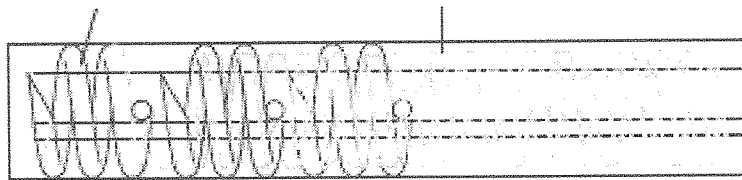

Fig.3



EUROPEAN SEARCH REPORT

Application Number
EP 16 16 8443

5

10

15

20

25

30

35

40

45

50

55

DOCUMENTS CONSIDERED TO BE RELEVANT			
Category	Citation of document with indication, where appropriate, of relevant passages	Relevant to claim	CLASSIFICATION OF THE APPLICATION (IPC)
X	US 2003/009441 A1 (HOLSTEN HENRY E [US] ET AL) 9 January 2003 (2003-01-09) * paragraphs [0081] - [0098]; figures 1-16 *	1-12	INV. A61B17/064 A61B17/068
X	WO 2004/112841 A2 (U S SURGICAL A DIVISION OF TYC [US]; ZERGIEBEL EARL M [US]) 29 December 2004 (2004-12-29) * page 5, line 9 - page 10, line 1; figures 1-8 *	1-9	ADD. A61B17/00
X	WO 2016/000246 A1 (COVIDIEN LP [US]; COVIDIEN CHINA MEDICAL DEVICES TECHNOLOGY CO LTD [CN] 7 January 2016 (2016-01-07) * paragraphs [0081] - [0097], [0137] - [0147]; figures 1-28,48-52 *	1-9	
X	US 2011/087240 A1 (SHIPP JOHN I [US]) 14 April 2011 (2011-04-14) * paragraphs [0049] - [0059], [0064] - [0069]; figures 1-6 *	1-9	
A	US 2014/014704 A1 (ONUKURI SAMARDH [US] ET AL) 16 January 2014 (2014-01-16) * paragraphs [0157] - [0169] *	2-5	
The present search report has been drawn up for all claims			
Place of search Munich		Date of completion of the search 2 June 2017	Examiner Maier, Christian
<p>CATEGORY OF CITED DOCUMENTS</p> <p>X : particularly relevant if taken alone Y : particularly relevant if combined with another document of the same category A : technological background O : non-written disclosure P : intermediate document</p> <p>T : theory or principle underlying the invention E : earlier patent document, but published on, or after the filing date D : document cited in the application L : document cited for other reasons & : member of the same patent family, corresponding document</p>			

EPO FORM 1503 03.02 (P04C01)

ANNEX TO THE EUROPEAN SEARCH REPORT
ON EUROPEAN PATENT APPLICATION NO.

EP 16 16 8443

5 This annex lists the patent family members relating to the patent documents cited in the above-mentioned European search report.
The members are as contained in the European Patent Office EDP file on
The European Patent Office is in no way liable for these particulars which are merely given for the purpose of information.

02-06-2017

Patent document cited in search report	Publication date	Patent family member(s)	Publication date
US 2003009441 A1	09-01-2003	AU 4494997 A	14-04-1998
		CA 2266326 A1	26-03-1998
		DE 69736601 T2	27-12-2007
		EP 0934024 A2	11-08-1999
		ES 2267152 T3	01-03-2007
		US 2003009441 A1	09-01-2003
		WO 9811814 A2	26-03-1998

WO 2004112841 A2	29-12-2004	AU 2004249161 A1	29-12-2004
		AU 2006201521 A1	09-11-2006
		CA 2527778 A1	14-06-2004
		CA 2544359 A1	25-10-2006
		EP 1635723 A2	22-03-2006
		EP 1716874 A2	02-11-2006
		EP 2298184 A1	23-03-2011
		EP 2308404 A1	13-04-2011
		EP 2314241 A1	27-04-2011
		EP 2893943 A1	15-07-2015
		ES 2370246 T3	13-12-2011
		JP 4914291 B2	11-04-2012
		JP 2006305348 A	09-11-2006
		JP 2007268291 A	18-10-2007
		JP 2007500583 A	18-01-2007
		JP 2011101814 A	26-05-2011
		US 2005267478 A1	01-12-2005
		US 2006241622 A1	26-10-2006
		US 2010191294 A1	29-07-2010
		US 2011282401 A1	17-11-2011
		US 2013018392 A1	17-01-2013
		US 2013197591 A1	01-08-2013
		US 2014114329 A1	24-04-2014
		US 2014371765 A1	18-12-2014
		US 2016066971 A1	10-03-2016
		US 2016135807 A1	19-05-2016
		US 2016270778 A1	22-09-2016
WO 2004112841 A2	29-12-2004		

WO 2016000246 A1	07-01-2016	CN 106535797 A	22-03-2017
		WO 2016000246 A1	07-01-2016

US 2011087240 A1	14-04-2011	US 2007038220 A1	15-02-2007
		US 2011087240 A1	14-04-2011
		US 2016074034 A1	17-03-2016

US 2014014704 A1	16-01-2014	EP 2848266 A1	18-03-2015
		US 2014014704 A1	16-01-2014

EPO FORM P0459

For more details about this annex : see Official Journal of the European Patent Office, No. 12/82

55

**ANNEX TO THE EUROPEAN SEARCH REPORT
ON EUROPEAN PATENT APPLICATION NO.**

EP 16 16 8443

5 This annex lists the patent family members relating to the patent documents cited in the above-mentioned European search report.
The members are as contained in the European Patent Office EDP file on
The European Patent Office is in no way liable for these particulars which are merely given for the purpose of information.

02-06-2017

10

Patent document cited in search report	Publication date	Patent family member(s)	Publication date
		WO 2015038763 A1	19-03-2015

15

20

25

30

35

40

45

50

EPO FORM P0459

For more details about this annex : see Official Journal of the European Patent Office, No. 12/82

55

REFERENCES CITED IN THE DESCRIPTION

This list of references cited by the applicant is for the reader's convenience only. It does not form part of the European patent document. Even though great care has been taken in compiling the references, errors or omissions cannot be excluded and the EPO disclaims all liability in this regard.

Patent documents cited in the description

- US 200810009395 A [0004]
- US 20070038220 A1 [0004]
- US 20070250064 A1 [0004]
- US 20030187465 A1 [0004]
- US 5366479 A [0004]

专利名称(译)	用于软组织的固定装置		
公开(公告)号	EP3195811A1	公开(公告)日	2017-07-26
申请号	EP2016168443	申请日	2016-05-04
[标]申请(专利权)人(译)	天助畅运医疗技术		
申请(专利权)人(译)	天助畅运医疗科技有限公司		
当前申请(专利权)人(译)	天助畅运医疗科技有限公司		
[标]发明人	SUN JIE QIAO HONGJIU CHEN FAN DING LINGCUI MENG KAI		
发明人	SUN, JIE QIAO, HONGJIU CHEN, FAN DING, LINGCUI MENG, KAI		
IPC分类号	A61B17/064 A61B17/068 A61B17/00		
CPC分类号	A61B17/064 A61B17/068 A61B2017/00004 A61B2017/00853 A61B2017/00889 A61B2017/0648 A61B2017/0649 A61B2017/0084		
审查员(译)	MAIER, CHRISTIAN		
优先权	201610051820.2 2016-01-25 CN 201620072770.1 2016-01-25 CN 201610051764.2 2016-01-25 CN 201620073762.9 2016-01-25 CN 201610051818.5 2016-01-25 CN 201610051765.7 2016-01-25 CN		
其他公开文献	EP3195811B1		
外部链接	Espacenet		

摘要(译)

本发明涉及医疗设备技术领域，尤其涉及一种带有可吸收螺钉或钛螺钉的软组织固定装置。用于软组织的固定装置包括驱动装置，螺旋管和驱动杆。通过螺纹将导管布置在螺旋管周围，并且在导管中布置多个可吸收螺钉或钛螺钉。在每个可吸收螺钉的钉梁上形成螺纹结构，并且在每个可吸收螺钉结构上设置引导弹簧。多个可吸收螺钉或钛螺钉以头对尾连接的形式串联连接，并用螺旋槽放入导管中。在拉动扳机时，驱动杆由使用中的驱动装置驱动旋转；此外，当腹腔镜疝气修复正在进行时，可吸收的螺钉或钛螺钉可以一个接一个地从导管中射出。具有本发明的可吸收螺钉或钛的软组织固定装置特别适用于腹腔镜疝气修复手术。此外，本发明的软组织固定装置具有抗粘连，操作方便可靠的特点，导管是可拆卸的更换元件，因此在更换导管后可以重复使用固定装置

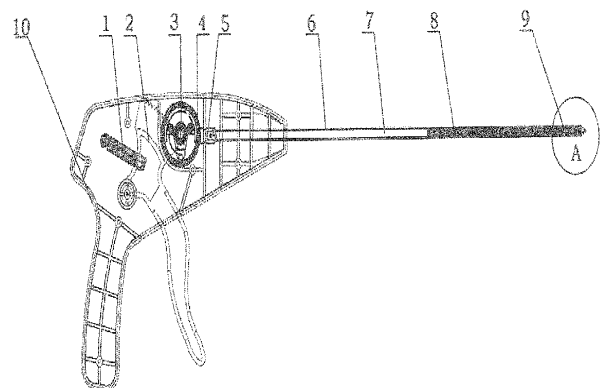

Fig.1