



(11) **EP 2 837 345 B1**

(12) **EUROPEAN PATENT SPECIFICATION**

(45) Date of publication and mention of the grant of the patent:
05.10.2016 Bulletin 2016/40

(51) Int Cl.:
A61B 17/34^(2006.01)

(21) Application number: **14186927.1**

(22) Date of filing: **26.01.2009**

(54) **Insufflating access system**

Insufflierendes Zugangssystem

Système d'accès d'insufflation

(84) Designated Contracting States:
AT BE BG CH CY CZ DE DK EE ES FI FR GB GR HR HU IE IS IT LI LT LU LV MC MK MT NL NO PL PT RO SE SI SK TR

(30) Priority: **25.01.2008 US 23539 P**

(43) Date of publication of application:
18.02.2015 Bulletin 2015/08

(62) Document number(s) of the earlier application(s) in accordance with Art. 76 EPC:
09703532.3 / 2 231 233

(73) Proprietor: **APPLIED MEDICAL RESOURCES CORPORATION**
Rancho Santa Margarita, CA 92688 (US)

(72) Inventors:
• **Albrecht, Jeremy J.**
Rancho Santa Margarita, CA California 92688 (US)
• **Johnson, Gary M.**
Rancho Santa Margarita, CA California 92688 (US)
• **Brustad, John R.**
Rancho Santa Margarita, CA California 92688 (US)

(74) Representative: **Dolleymores**
9 Rickmansworth Road
Watford, Hertfordshire WD18 0JU (GB)

(56) References cited:
EP-A1- 1 733 707 WO-A1-03/020140
US-A1- 2005 070 851 US-A1- 2005 288 622
US-A1- 2007 239 108

EP 2 837 345 B1

Note: Within nine months of the publication of the mention of the grant of the European patent in the European Patent Bulletin, any person may give notice to the European Patent Office of opposition to that patent, in accordance with the Implementing Regulations. Notice of opposition shall not be deemed to have been filed until the opposition fee has been paid. (Art. 99(1) European Patent Convention).

Description

BACKGROUND

Technical Field

[0001] This application is directed to an insufflating access system.

Description of the Related Art

[0002] In laparoscopic procedures in which a patient's abdomen is insufflated or inflated with gas, placing a device through which the abdomen is insufflated, also referred to as a first entry device, is often problematic. Because the peritoneum directly contacts the organ bed, a device puncturing the peritoneum can also damage the underlying organ bed. Placing subsequent devices is less dangerous because the insufflating the abdomen lifts the peritoneum above a gas-fill space or cavity above the organ bed, thereby reducing the risk of inadvertent damage thereto.

[0003] Several techniques are used to achieve pneumoperitoneum in laparoscopic surgery. A first technique uses a Veress needle, which is a sharp needle placed blindly through the abdominal wall into the abdominal cavity. An insufflation gas, for example, CO₂, is then pumped through the hollow Veress needle and into the abdominal cavity, thereby insufflating the peritoneal cavity. The Veress needle technique, also known as a controlled stab, is capable of damaging organs such as the intestinal tract. The technique provides little or no feedback to the surgeon that any damage to an anatomic structure has occurred.

[0004] A second technique is known as the Hassan technique in which a surgeon performs a mini-laparotomy through the abdominal layers into the abdominal cavity, through which a trocar is inserted and the abdomen insufflated. The Hassan technique is a cut-down technique that results in larger abdominal defects and increased patient scarring. The technique is also difficult to perform on obese patients with very thick abdominal walls.

[0005] In a third technique, the surgeon places a trocar optically, visualizing the abdominal layers as the trocar is placed through the abdominal wall through a laparoscope disposed within the obturator of the trocar. The tip of the obturator can penetrate about 2 cm (about 0.75") into the organ bed of the abdominal cavity when placing the cannula and establishing pneumoperitoneum.

[0006] In a fourth technique, the abdominal layers are visualized while the trocar is advanced through the abdominal wall. As soon as the tip of the obturator punctures the peritoneum, gas is pumped through the trocar system into the abdominal cavity through vent holes disposed at the tip of the obturator. The fourth technique uses a vacuum release, which causes the organs to fall away from the abdominal wall, thereby creating a space in the abdominal cavity for the obturator tip. Accordingly, the ab-

dominal cavity can be inflated with minimal penetration into the space. As soon as the tip of the obturator punctures the peritoneum, gas enters the abdominal cavity through the vent holes in the tip of the obturator, thereby reducing the negative pressure caused by the surgeon's lifting of the abdominal wall, and in turn, creating a space above the organ bed into which the trocar system is fully inserted into the cavity. A seal is disposed within the obturator that provides a gas tight seal both with and without the laparoscope in place. The vent holes at the tip of the obturator allow moisture and tissue to enter the obturator, however, which obscure the field of view within the obturator tip. Gas flowing directly past the laparoscope within the obturator can cool the laparoscope, thereby fogging of the lens thereof.

[0007] European Patent Application EP 1733707 A1, US2005/288622A1, US2005/070851A1 and International Patent Application WO 03/020140 A1 disclose known access systems of the type to which the present invention relates.

SUMMARY OF THE INVENTION

[0008] The present invention provides an access system in accordance with Claim 1. This may permit insufflation of a body cavity prior to the insertion of a cannula into the body cavity. The access system has a closed configuration, in which a distal end of the access system is fluidly isolated from the fluid flow channel, and an open configuration, in which the distal end of the access system is fluidly connected to the fluid flow channel, thereby permitting fluid flow, for example, an insufflation gas into a body cavity.

[0009] In some embodiments, the trocar seal assembly further comprises a zero seal.

[0010] In some embodiments, the distal end of the cannula comprises an angled tip.

[0011] In some embodiments, the fluid port is disposed on the trocar seal assembly.

[0012] In some embodiments, the fluid flow seal is integrated with a cannula tip disposed at the distal end of the cannula. In some embodiments, the fluid flow seal is disposed proximal of the distal end of the cannula. In some embodiments, the fluid flow seal is substantially perpendicular to the longitudinal axis of the axis channel. In some embodiments, the fluid flow seal is not perpendicular to the longitudinal axis of the axis channel.

[0013] Some embodiments further comprise a laparoscope.

[0014] In some embodiments, the fluid flow channel comprises a space defined by the lumen of the cannula and the body of the obturator.

[0015] In some embodiments, in the closed position, the obturator is rotated in the access channel compared with the open position.

[0016] Some embodiments further comprise means for visually monitoring the position of the penetrating tip through a laparoscope.

BRIEF DESCRIPTION OF THE DRAWINGS

[0017]

FIG. 1A, not in accordance with the present invention, is a perspective view of an example of an insufflating access system. FIG. 1B, not in accordance with the present invention, is a perspective cutaway view of a trocar of the insufflating access system illustrated in FIG. 1A. FIG. 1C, not in accordance with the present invention, is a side cutaway view of the trocar illustrated in FIG. 1B.

FIG. 1D, not in accordance with the present invention, is a side cutaway view of the insufflating access system illustrated in FIG. 1A in the closed configuration. FIG. 1E, not in accordance with the present invention, is a side cross-sectional view of the insufflating access system illustrated in FIG. 1A in a closed configuration. FIG. 1F, not in accordance with the present invention, is a cross-sectional view of the insufflating access system illustrated in FIG. 1A in an open configuration.

FIG. 2A, not in accordance with the present invention, is a perspective view of an insufflating access system. FIG. 2B, not in accordance with the present invention, is a perspective view of an embodiment of an obturator from the insufflating access system illustrated in FIG. 2A. FIG. 2C, not in accordance with the present invention, is a side cutaway view of the insufflating access system illustrated in FIG. 2A in a closed configuration. FIG. 2D, not in accordance with the present invention, is a side cutaway view of the insufflating access system illustrated in FIG. 2C in an open configuration.

FIG. 3A is a perspective view of an embodiment of an insufflating access system according to the present invention in an open configuration. FIG. 3B is a side cross section of the insufflating access system illustrated in FIG. 3A in a closed configuration. FIG. 3C is a side see-through view of another embodiment of an insufflating access system, in accordance with the present invention, in an open configuration.

FIG. 4A is a side cross section of another embodiment of an insufflating access system in a closed configuration. FIG. 4B is a side cross section of the insufflating access system illustrated in FIG. 4A in an open configuration. FIG. 4C is a perspective view of an obturator of the insufflating access system illustrated in FIGS. 4A and 4B.

FIG. 5A-5C, not in accordance with the present invention, schematically illustrate an embodiment of a method for placing the embodiment of the access device illustrated in FIGS. 1A-1F.

DETAILED DESCRIPTION OF CERTAIN EMBODIMENTS

[0018] FIG. 1A is a perspective view of an embodiment of an insufflating access system 100 not forming an embodiment of the present invention, which comprises a trocar 110 and an obturator 160 slidably insertable into the trocar 110. The insufflating access system 100 also comprises a fluid flow channel, which is discussed in greater detail below. The trocar 110 and obturator 160 comprise suitable biologically compatible materials.

[0019] FIG. 1B is a perspective cutaway view and FIG. 1C is a partial side cross section of the trocar 110. The trocar 110 comprises a proximal end 112 and a distal end 114. A trocar seal assembly 120 is disposed at the proximal end 112 of the trocar, and an elongate cannula 130 extends from the trocar seal assembly 120 and is disposed at the distal end 114 of the trocar. An access channel 116 extends through the trocar seal assembly 120 and the cannula 130, from the proximal end 112 to the distal end 114 of the trocar. The access channel 116 defines a longitudinal axis. In some embodiments, the trocar seal assembly 120 and the cannula 130 are integrated, while in other embodiments, the trocar seal assembly 120 and the cannula 130 are separate components, and in some embodiments, releasably coupled.

[0020] In the illustrated embodiment, the trocar seal assembly 120 comprises a first seal 122 and a second seal 124 disposed on the access channel 116 within a trocar seal housing 126. The first seal 122 is an instrument seal, which forms a substantially fluid tight seal with an instrument extending therethrough, thereby preventing fluid from escaping from the proximal end 112 of the trocar. In some embodiments, the first seal 122 comprises a septum seal. The second seal 124 is a zero seal, which forms a fluid tight seal with no instrument extending therethrough, preventing fluid from escaping from the proximal end 112 of the trocar. In some embodiments, the second seal 124 comprises a duckbill valve, a double duckbill valve, and/or a flap valve. The second seal 124 is optional in some embodiments. For example, in some embodiments, the first seal 122 provides both an instrument seal and a zero seal, for example, a valve comprising a gel material. Other embodiments do not comprise a zero seal. In some embodiments, the first seal 122 and the second seal 124 comprise an elastomer, for example rubber, synthetic rubber, silicone, ethylene propylene diene monomer (EPDM), ethylene-propylene copolymer (EP rubber), polyisoprene, polybutadiene, polyurethane, styrene-butadiene, ethylene vinyl acetate (EVA), polychloroprene (Neoprene®), perfluorelastomer (Kalrez®), and the like.

[0021] The cannula 130 comprises a proximal end, at which the trocar seal assembly 120 is disposed, and a distal end terminating in a tip 132. In the illustrated embodiment, the tip 132 of the cannula is angled with a beveled edge. The angled tip 132 facilitates insertion through tissue. In other embodiments, the tip 132 is not

angled. The cannula **130** comprises a hollow tube open at the proximal and the distal ends. The hollow tube defines a lumen **134**, through which the access channel **116** extends. One or more optional vents **136** perforate the cannula **130** at or near the distal end thereof. In the illustrated embodiment, the cannula **130** has a generally circular cross section, although those skilled in the art will understand that other embodiments have other suitable cross sections, for example, oval, elliptical, diamond, square, polygonal, and the like.

[0022] A fluid flow seal **140** is disposed within the lumen of the cannula **130**, on an inner wall of the hollow tube. The fluid flow seal **140** is positioned, dimensioned, and configured for sealing contacting the body **162** of the obturator, as discussed in greater detail below. In the illustrated embodiment, the fluid flow seal **140** is disposed near the tip **132** or distal end of the cannula. The fluid flow seal **140** is substantially normal or perpendicular to the longitudinal axis of the trocar **110**, and consequently, is generally circular in the illustrated embodiment. In other embodiments, the fluid flow seal **140** is disposed at another location. For example, in some embodiments, the fluid flow seal **140** is disposed at or integrated with the tip **132** of the cannula, or spaced adjacent to or just slightly inward from the tip **132** at the distal-most end. In some of these embodiments in which the tip **132** is not perpendicular to the longitudinal axis of the trocar **110**, the fluid flow seal **140** also subtends a non-normal angle with the longitudinal axis, and consequently, is elliptical or oval rather than circular. In some embodiments, the fluid flow seal **140** and the tip **132** subtend about the same angle with the longitudinal axis, while in other embodiments, the fluid flow seal **140** and the tip **132** subtend different angles with the longitudinal axis. Some embodiments of the fluid flow seal **140** comprise a plurality of sub-seals, which are disposed at about the same location in some embodiments, and disposed in a plurality of locations in other embodiments. The fluid flow seal **140** comprises a suitable elastomer for example, at least one of rubber, synthetic rubber, silicone, ethylene propylene diene monomer (EPDM), ethylene-propylene copolymer (EP rubber), polyisoprene, polybutadiene, polyurethane, styrene-butadiene, ethylene vinyl acetate (EVA), polychloroprene (Neoprene®), perfluorelastomer (Kalrez®), and the like.

[0023] A fluid port **150** is disposed on the housing **126** of the trocar seal assembly, fluidly connected with the access channel **116** distal of the first **122** and second **124** seals. The fluid port **150** comprises a stopcock in the illustrated embodiment, and terminates in a fitting that permits coupling to a fluid and/or suction source, for example, a Luer fitting. In other embodiments, the fluid port **150** has another location, for example, on the cannula **130** or the obturator **160**. Embodiments of the fluid port **150** are useful for introducing and/or venting an insufflation gas, for example, carbon dioxide, therethrough. Other fluids are introduced and/or vented in other embodiments.

[0024] The trocar **110** is typically manufactured in a range of sizes to accommodate instruments of different diameters, for example, up to about 5 mm, up to about 8 mm, up to about 11 mm, up to about 12 mm, or up to about 15 mm. Embodiments of the trocar **110** have working cannula lengths of about 55 mm, about 75 mm, about 100 mm, or about 150 mm.

[0025] As best seen in FIG. **1D**, which is a side cutaway view of the insufflating access system **100**, the obturator **160** comprises an elongate body **162** comprising a proximal end terminating in a handle **164** and a distal end terminating in a tissue penetrating tip **166**. A diameter of the tip **166** converges from a proximal end to a distal end thereof. The body **162** and tip **166** of obturator is slidably insertable into and removable from the access channel **116** through the proximal end of the trocar **110**. In a fully inserted configuration, the tip **166** of the obturator extends out of the distal end or tip **132** of the cannula **130**. The first seal **122** of the trocar seal assembly forms an instrument seal with the body **162** of the cannula, thereby substantially preventing fluid leaking from the proximal end of the access channel **116**. In the illustrated embodiment, the body **162** comprises a hollow, instrument well **168**, which is open at the handle **162** at the proximal end of the obturator, and which extends to the tip **166** of the obturator. The instrument well **168** is dimensioned to receive a laparoscope through the proximal opening thereof. When fully inserted, an end of the laparoscope extends through the body **162** of the obturator into or proximal to the tip **166**. In the illustrated embodiment, the tip **166** comprises at least a transparent or windowed portion through which the laparoscope images tissue proximal to the tip **166**, for example, for monitoring the position of the tip **166** during the insertion of the access system **100** into a body cavity. Some embodiments of the tip **166** comprise markers or another type of visually enhancing or facilitating features, which assist in viewing the tissue and body cavity, and thus, traversal of the tip **166** through the body. In some embodiments, the laparoscope is fully inserted in the instrument well **168**, thereby preventing or reducing fogging thereof. Accordingly, some embodiments comprise at least one of a distal laparoscope seal, membrane, or lock in that provides at least one of holding the laparoscope in a fully or nearly fully inserted position, preventing or reducing fogging, and preventing or reducing other types of interference of the viewing area of the laparoscope.

[0026] FIG. **1E** is a side cross section of the insufflating access system **100** in a closed configuration and FIG. **1F** is a side cross section of the insufflating access system **100** in an open configuration. The lumen **134** of the cannula and the body **162** of the obturator together define a fluid flow channel **180** therebetween, which extends longitudinally in the access channel **116**. A proximal end **182** of the fluid flow channel is fluidly connected to the fluid port **150**. A distal end **184** of the fluid flow channel extends to the distal end of the access system **100**, which in the illustrated embodiment, comprises the tip **132** of

the cannula. In the illustrated embodiment, the lumen **134** of the cannula and the body **162** of the obturator are both generally circular and define a fluid flow channel **180** with a generally annular cross section. In other embodiments, cross-sectional shapes of the lumen **134** of the cannula and the body **162** of the obturator are different from each other, and the cross section of the fluid flow channel **180** has another shape.

[0027] A size of a space or gap between the tip **166** of the obturator and the tip **132** of the cannula is selected to prevent or reduce coring of tissue as the access system is advanced. In some embodiments, the gap between the tip **166** of the obturator and the tip **132** of the cannula provides sufficient gas flow for insufflation, which is discussed in greater detail below. In some embodiments, a gap between the body **162** of the obturator and the lumen **134** of the cannula is not uniform longitudinally, for example, wider at the proximal end **112** and narrower at the distal end **116**.

[0028] In the closed configuration illustrated in FIG. **1E**, the tip **166** of the obturator extends from the tip **132** of the cannula in a configuration suitable for inserting the access system **100** through a body wall and into a body cavity. The position of the obturator **160** in this configuration is referred to as a closed position. In the closed configuration, the fluid flow seal **140** sealingly contacts the body **162** of the obturator, thereby cooperating therewith to prevent fluid flow through the fluid flow channel **180**, from the fluid port **150**, and out through the tip **132** of the cannula. Accordingly, the fluid port **150** is not fluidly connected with the distal end of the fluid flow channel **184**.

[0029] In the open configuration illustrated in FIG. **1F**, the obturator **160** is partially withdrawn from access channel **116**, that is translated proximally along the longitudinal axis compared with the configuration illustrated in FIG. **1E**. The position of the obturator **160** in this configuration is referred to as an open position. In the illustrated embodiment, the body **162** of the obturator is proximal of the fluid flow seal **140**, and consequently, does not make contact and form a seal therewith. Accordingly, in the open configuration, the distal end **184** of the fluid flow channel is fluidly connected with the fluid port **150**. In some embodiments, the fluid flow seal **140** contacts a portion of the body **162** of the obturator in the open configuration, but does not sealingly contact therewith. For example, in some embodiments, at least one of the fluid flow seal **140**, and a transition between the body **162** and tip **166** of obturator are not normal or perpendicular to the longitudinal axis. In some of these embodiments, in some positions of the obturator **160** in the access channel, the body **162** of the obturator contacts only a portion of the fluid flow seal **140** rather than the entire sealing surface thereof, and consequently, does not form a seal therewith.

[0030] Some embodiments of the access system **100** comprise an indicator of the configuration thereof. For example, some embodiments comprise indicia on the obturator **160** and/or the trocar **110** that indicate the position

of the obturator **160** in the open and/or closed position. Some embodiments comprise an audio and/or visual indicator of fluid flow through the fluid flow channel **180** and/or fluid port **150**, for example, a spinning disk, a spinning ball, a lamp, a whistle, and/or an alarm.

[0031] Some embodiments comprise one or more mechanical features that indicate the state of and/or lock the access system **100** into at least one of the open configuration and the closed configuration, for example, detents, latches, stops, and the like.

[0032] FIG. **2A** is a perspective view of another insufflating access system **200** not in accordance with the present invention, which is generally similar to that in FIGS. **1A-1F**, comprising a trocar **210**, an obturator **260** inserted in the trocar **210**, and a laparoscope **290** inserted into the obturator **260**. FIG. **2B** is a perspective view of an embodiment of the obturator **260**, which is similar to the embodiment of the obturator **160** described above, and comprises an elongate body **262**, a handle **264** disposed at the proximal end, a tip **266** disposed at the distal end, and an instrument well **268** extending longitudinally from an instrument well **268** extending longitudinally from an opening in the handle **264** at the proximal end of the obturator to the tip **266** at the distal end thereof.

[0033] The obturator **260** further comprises a slot **272** that extends longitudinally on the body **262** thereof. As will be apparent from the description below, the slot **272** incorporates the instrument well **268** into the fluid flow channel **280** in the illustrated embodiment. Because the fluid flow channel **280** comprising the instrument well **268** has a larger cross-sectional area compared with the fluid flow channel **180** of embodiment illustrated in FIGS. **1A-1F**, embodiments of the access system **200** exhibit increased fluid flow. A proximal end of the slot **272** is positioned such that the slot **272** does not interfere with the instrument seal between the body **262** and the trocar seal assembly **220** when the obturator **260** is in the open position or the closed position. A distal end of the slot **272** is positioned such that fluid does not flow from the slot **272** in the closed configuration, that is, the distal end of the slot **272** is fluidly isolated from the distal end of the access system **200**. The open configuration permits fluid flow from the distal end of the slot **272**, that is, the distal end of the slot **272** is fluidly connected to the distal end of the access system **200**. In the illustrated embodiment, the slot **272** perforates the body **262** of the obturator into the instrument well **268**. Accordingly, the illustrated embodiment comprises a seal between the proximal end of the obturator **260** and the laparoscope **290**, thereby preventing or reducing fluid flow therefrom. The seal is disposed on at least one of the laparoscope **290** and the obturator **260**. In some embodiments, the slot **272** does not perforate the body **262** of the obturator, for example, comprising one or more longitudinal grooves disposed on an outer surface of the body **262**. The seal between the proximal end of the obturator **260** and the laparoscope **190** is optional in these embodiments. Some embodiments of the fluid flow channel **280** comprise one or

more longitudinal grooves disposed on an inner wall of the cannula **230**.

[0034] FIG. **2C** is a side cutaway view of the insufflating access system illustrated in FIG. **2A** in a closed configuration. In the closed position, the obturator **260** is inserted into the access channel of the trocar **210** with the tip **266** extending from the tip **232** of the cannula in a tissue penetrating position. The proximal end of the slot **272** is disposed below the instrument seal of the seal assembly **220**, in fluid communication with the fluid port **250**. The distal end of the slot **272** is disposed proximal to the fluid channel seal **240**, which seals with the body **262** of the obturator, thereby fluidly isolating the slot **272** from the tip **232** of the cannula and the distal end of the access system **200**.

[0035] FIG. **2D** is a side cutaway view of the insufflating access system illustrated in FIG. **2C** in an open configuration in which the obturator **260** is advanced distally in the access channel, for example, using the handle **264**, thereby advancing the distal end of the slot **272** past the fluid channel seal **240**, and thereby releasing the seal between the body **262** of the obturator and the fluid channel seal **240**. In the illustrated embodiment, the slot **272** has about the same length as the cannula **230**, extending from about the position of the fluid inlet to past a proximal portion of the angled tip **232** of the cannula, with which the slot **272** is aligned. Accordingly, alignment of the distal end of the slot **272** with the proximal portion of the angled tip **232** exposes the distal end of the slot **272**, thereby providing a fluid flow channel **280** that permits insufflation gas to exit directly out the slot **272** and into the body cavity. In some embodiments, the obturator **260** and trocar **210** are keyed or otherwise configured to prevent rotation therebetween, thereby locking the slot **272** in the exposed condition when the access system **200** is in the open configuration. Those skilled in the art will understand that some embodiments in which the slot **272** is rotated relative to the configuration illustrated in FIG. **2D** such that the distal end of the slot **272** and the proximal portion of the angled tip **232** are not aligned, also permit fluid flow therethrough, but at reduced flow rates.

[0036] In other arrangements, the access system **200** has an open configuration, as illustrated in FIG. **2A**, with a fluid flow seal **240** disposed in the cannula **230** at or near the angled tip **232** thereof. As discussed above, the fluid flow seal **240** may subtend the same or a similar angle as the tip **232**. Rotating the obturator **260** positions the entirety of the slot **272** within the cannula **230**, proximal of the fluid flow seal **240**, thereby converts the open configuration to the closed configuration in which the distal end of the slot **272** is fluidly isolated from the distal end of the access system **200**, and preventing fluid flow therefrom. In some of these embodiments, rotation of the handle **264** of the obturator is restricted such that the device **200** is in the open configuration at a first limit of the rotation and in a closed configuration at a second limit thereof.

[0037] FIG. **3A** is a perspective view of an embodiment

of an insufflating access system **300**, in accordance with the present invention, in an open configuration. FIG. **3B** is a side cross section of the insufflating access system **300** illustrated in FIG. **3A** in a closed configuration. The embodiment of the access system **300** illustrated in FIGS. **3A** and **3B** is similar to the embodiments described above. Like the embodiment illustrated in FIGS. **2A-2D**, a gas flow channel in the illustrated embodiment incorporates an instrument well, thereby increasing the cross sectional area thereof. The access system **300** comprises a trocar **310** and an obturator **360**.

[0038] As best seen in FIG. **3B**, the obturator **360** comprises at least one proximal opening **372** and at least one distal opening **374**, both of which perforate the body **362** of the obturator into the instrument well **368**. In the illustrated embodiment, the at least one proximal opening **372** and the at least one distal opening **374** are both generally circular or oval, but in other embodiments, independently have other suitable shapes.

[0039] A fluid flow seal **340** is disposed at or integrated with the cannula tip **332** in the illustrated embodiment, as described above. Some embodiments of the trocar **310** further comprise a second fluid flow seal, either in addition to or instead of the fluid flow seal **340**. Some embodiments of the second fluid flow seal comprise a tubular member, disposed in the seal assembly through which the obturator **360** extends, wherein the tubular member

comprises at least one opening that is aligned with the at least one proximal opening **372** when the obturator is in an open position, thereby permitting fluid flow therethrough. The at least one opening in the tubular member is not aligned with the at least one proximal opening **372** when the obturator is in a closed position, thereby preventing fluid flow therethrough.

[0040] In the illustrated embodiment, the access system **300** is converted from the open configuration illustrated in FIG. **3A** to the closed configuration illustrated in FIG. **3B** by rotating the obturator **360**, for example, using the handle. In the illustrated embodiment, the obturator **360** is rotated about 180° between the views illustrated in FIGS. **3A** and **3B**, although those skilled in the art will understand that other rotational angles are used in other embodiments. The particular rotational angle depends on factors including the size and shape of the distal opening **374**, the location of the distal opening **374**, the location of the fluid flow seal **340**, the angle of the fluid flow seal **340**. In the illustrated embodiment, fluid flows from the fluid port **350**, into the proximal opening **372**, into the instrument well **368**, and out of the distal opening **374**. In the illustrated embodiment, the distal opening **374** is exposed in the open configuration. In the closed configuration, the distal opening **374** is positioned proximal of the fluid flow seal **340**, which forms a seal with a portion of the body **362** of the obturator distal of the distal opening **374**, thereby preventing fluid flow therefrom.

[0041] FIG. **3C** is a see-through view of another embodiment of an insufflating access system **300**, in accord-

ance with the present invention, in an open configuration. In the illustrated embodiment, the trocar **310** is similar to the embodiment illustrated in FIGS. **1A-1F** in which the fluid flow seal **340** is disposed in the lumen **334** of the cannula proximal to the tip **332**. In the illustrated embodiment, the access system **300** is converted from the illustrated open configuration to a closed configuration by withdrawing the obturator longitudinally toward the proximal end, thereby positioning the distal opening **374** proximal of the fluid flow seal **340**. The fluid flow seal **340** seals with a portion of the body **362** of the obturator distal of the distal opening **374**, thereby preventing fluid flow therefrom.

[0042] FIG. **4A** is a side cross section of another embodiment of an insufflating access system **400** in a closed configuration. FIG. **4B** is a side cross section of the insufflating access system **400** illustrated in FIG. **4A** in an open configuration. The insufflating access system **400** is generally similar to the insufflating access systems described above, and comprises a trocar **410** and an obturator **460**. In the illustrated embodiment, the trocar **410** is generally similar to the embodiment illustrated in FIGS. **1A-1F** and described above. The trocar **410** comprises a fluid flow seal **440** disposed in the lumen **434** of a cannula **430** thereof, proximal of the tip **432** of the cannula. In the illustrated embodiment, the fluid flow seal **440** is generally perpendicular to a longitudinal axis of the trocar **410**.

[0043] As best seen in FIG. **4C**, which is a perspective view of an embodiment of an obturator **460**, the obturator **460** comprises a plurality of openings **472** disposed longitudinally and circumferentially on the body **462** of the obturator, which extend into the instrument well **468**. The illustrated embodiment comprises a plurality of proximal openings **472a**, a plurality of distal openings **472b**, and a plurality of optional intermediate openings **472c**.

[0044] In converting the access system **400** from the closed configuration illustrated in FIG. **4** to the open configuration illustrated in FIG. **4B**, the obturator **460** is translated proximally along the longitudinal axis. In the closed configuration illustrated in FIG. **4A**, the fluid flow seal **440** seals with a portion of the body **462** of the obturator distal of the distal openings **472b**, thereby preventing fluid flow out of the tip **432** of the cannula at the distal end of access system **400**. In the open configuration illustrated in FIG. **4B**, because the body **462** of the obturator is proximal of the fluid flow seal **440**, the body **462** and fluid flow seal **440** do not cooperate in forming a seal in the fluid flow channel **480**. Accordingly, fluid flow is possible from the fluid port **450** into and through the fluid flow channel **480**. In the illustrated embodiment, the fluid flow channel **480** comprises both the instrument well **468** and a space between the lumen **434** of the cannula and the body **462** of the obturator. As best seen in FIG. **4B**, in the illustrated embodiment, the proximal openings **472a** are disposed proximal to the cannula **430** within the trocar seal assembly **420**, thereby increasing a cross sectional area around the proximal openings **472a** and increasing fluid flow

therethrough. Fluid continues flowing longitudinally towards the distal end of the access system **400** through both the instrument well **468** and the space between the lumen **434** of the cannula and the body **462** of the obturator. At the distal end of the obturator **460**, fluid exits the instrument well **468** through the distal openings **472c** and continues distally in the space between the lumen **434** of the cannula and the body **462** of the obturator. The fluid exits the access system **400** through the tip **432**.

[0045] Although embodiments of the insufflating access system are applicable to any endoscopic application using insufflation, a prototypical application is in laparoscopic procedures. Consequently, for purposes of illustration only, the following describes a method for inserting an endoscopic port or trocar of an insufflating access system, and establishing pneumoperitoneum in laparoscopic surgery with reference to the embodiment illustrated in FIGS. **1A-1F**. Those skilled in the art will understand that the method is also applicable to other embodiments of the access system disclosed herein.

[0046] The obturator **160** is inserted into the trocar **110** and positioned in the closed configuration illustrated in FIG. **1E**. A laparoscope is inserted into the instrument well **168** of the obturator and the laparoscope coupled with an imaging system, for example, a camera and a video monitor. The fluid port **150** is fluidly coupled to a source of pressurized insufflation gas.

[0047] The user positions the tissue penetrating tip **166** in an incision made at a desired location on the patient's abdomen **500** and advances the insufflating access system **100** through the abdominal wall **502** as illustrated schematically in FIG. **5A**. The user monitors the position of the tip **166** through the laparoscope and imaging system. When the user observes the tip **166** penetrating the peritoneum **504**, as illustrated in FIG. **5B**, the user converts the access system **100** to the open configuration. In the illustrated embodiment, the user urges the obturator **160** proximally, for example, pulling on the handle **162** to convert the access system **100** to the open configuration illustrated in FIG. **1F**. As discussed above, in some embodiments, the obturator **160** and/or trocar **110** comprise one or more marks or indicia that indicate the position of the obturator **160** in the open position. With the access system **100** in the open configuration, insufflation gas flows from the source of insufflation gas, into the fluid port **150**, into the proximal end **182** of the fluid flow channel, longitudinally through the fluid flow channel **180**, past the fluid flow seal **140**, past the partially withdrawn tip **166** of the obturator, and out the tip **132** of the cannula. Some gas may also flow out of the vents **136**, particularly if the tip **132** of the cannula is fully or partially blocked. The gas flows through the opening in the peritoneum into the abdominal cavity, thereby insufflating the abdominal cavity **506** and establishing pneumoperitoneum as illustrated in FIG. **5C**.

[0048] Accordingly, embodiments of the access system **100** and method provide an accurate and simple method for gaining access to the abdominal cavity for

laparoscopic surgery. In other embodiments, the insufflating access system **100** provides access to the abdominal cavity through another surface adjacent to the peritoneal lining of the abdominal cavity, for example, the cul-de-sac of the vagina, any point along the gastro-intestinal tract from the diaphragm to the anus, or one of the great vessels such as the abdominal aorta or vena cava. Embodiments of the access system **100** and method provide access to other internal structures, for example, the kidney, the stomach, and/or the third ventricle of the brain, or any hollow organ for which accurate and shallow entry and the subsequent flow of gas or liquid is desired.

[0049] Disposing a fluid flow seal **140** between the obturator **160** and the distal end **114** of the cannula permits the device **100** to be fluidly coupled with a source of CO₂ while the device **100** is advanced through the abdominal wall **502**. As soon as the peritoneum **504** is punctured by the tip **166** of the obturator, the surgeon stops forward movement of the device **100** and dislocates the fluid flow seal **140** between the obturator **160** and the cannula **130**, thereby allowing the gas to flow through the gas flow channel **180** and out of the device **100**. The gas, following a path of least resistance, flows between the tip **166** and the abdominal wall **502**, through the opening made in the peritoneum **504**, and finally into the abdominal cavity **506**.

[0050] Consequently, pneumoperitoneum is established with reduced penetration into the organ bed because the tip **166** of the obturator does not extend as far beyond the peritoneum as in embodiments in which the tip comprises vent holes through which gas insufflates the abdominal cavity. Embodiments of the device **100** also do not comprise at least one of: seals within the obturator and gas channels around the laparoscope. Some embodiments eliminate or reduce the possibility of fluid and/or tissue entering the visual field within the obturator tip **166**. In some methods, the peritoneum **504** is punctured and the abdominal cavity **506** insufflated without further penetration of the tip **166** beyond the peritoneum **504** and into the abdominal cavity **506** or organ bed.

[0051] While certain embodiments have been particularly shown and described with reference to exemplary embodiments thereof, it will be understood by those of ordinary skill in the art that various changes in form and details may be made therein without departing from the scope of the present invention as defined by the following claims.

Claims

1. An insufflating surgical access system (300, 400) comprising:

a trocar (310,410) comprising:

a proximal end and a distal end ;

a trocar seal assembly (420) disposed at the proximal end of the trocar (110), the trocar seal assembly (420) comprising an instrument seal;

an elongate cannula (430) disposed at the distal end of the trocar, the cannula (430) comprising a tubular wall defining a lumen (334, 434), an open proximal end, and an open distal end;

an access channel defining a longitudinal axis, extending through the trocar seal assembly (420) and the lumen (334, 434) of the cannula (430), from the proximal end of the trocar to the distal end of the trocar;

a fluid port (350, 450) disposed at the proximal end of the trocar; and

a fluid flow seal (340, 440) disposed in the access channel;

the system further comprising an obturator (360, 460) comprising:

an elongate body (362, 462) comprising a proximal end and a distal end;

at least one proximal opening (372) and at least one distal opening (374) perforating the elongate body (362);

a tissue penetrating tip disposed at the distal end wherein at least a portion of the tip of the obturator (360, 460) is transparent;

an instrument well (368) open at a proximal end of the obturator (360, 460), extending longitudinally through the body (362, 462) of the obturator (360, 460), terminating at the tip of the obturator, and dimensioned to receive a laparoscope therein; and

a handle disposed at the proximal end,

wherein the obturator (360, 460) is slidably insertable into a proximal end of the access channel, and the tip of the obturator (360, 460) extends out of the distal, open end of the cannula (430) when fully inserted therethrough; and

a fluid flow channel (480) fluidly connected to the fluid port (350, 450) of the trocar, including the instrument well (368) and extending to a distal end of the insufflating access system (300,400), and comprising the at least one proximal opening (372) and the at least one distal opening (374) disposed in the body of the obturator,

wherein the obturator (360,460) in the access channel has

a closed position, in which the body (362, 462) of the obturator (360, 460) sealingly contacts the fluid flow seal (340, 440), thereby preventing fluid flow through the fluid flow channel (480), and

an open position, in which the body (362, 462) of the obturator (360, 460) does not sealingly contact the

- fluid flow seal (340, 440), thereby allowing fluid flow through the fluid flow channel (480), wherein in the open position, the distal opening (374) is exposed and, in the closed position, the distal opening (374) is positioned proximal of the fluid flow seal (340) which forms a seal with a portion of the elongate body (362) of the obturator (360,460) distal of the distal opening (374) thereby preventing fluid flow.
2. The access system (300,400) of claim 1 wherein trocar seal assembly (120) further comprises a zero seal.
 3. The access system (300,400) of claim 1 wherein the distal end of the cannula (430) comprises an angled tip (332, 432).
 4. The access system (300,400) of claim 1 wherein the fluid port (350,450) is disposed on the trocar seal assembly (420).
 5. The access system (300,400) of claim 1 wherein the fluid flow seal (340, 440) is integrated with a cannula tip (332,432) disposed at the distal end of the cannula (430).
 6. The access system (300,400) of claim 1 wherein the fluid flow seal (340,440) is disposed proximal of the distal end of the cannula (430).
 7. The access system (300,400) of claim 1 wherein the fluid flow seal (340,440) comprises a plurality of sub-seals.
 8. The access system (300,400) of claim 1 wherein the fluid flow channel (480) comprises a space defined by the lumen (334, 434) of the cannula (430) and the body (362,462) of the obturator (360,460).
 9. The access system (300,400) of claim 1 wherein the fluid flow channel (480) comprises one or more longitudinal grooves disposed on an inner wall of the cannula (430).
 10. The access system (300,400) of claim 1 wherein the fluid flow seal (340,440) is not perpendicular to the longitudinal axis of the access channel.
 11. The access system (300,400) of claim 1 wherein the obturator (360,460) is converted from an open position to a closed position by withdrawing the obturator (360) longitudinally toward the proximal end to position the at least one distal opening (374) proximal of the fluid flow seal (340).
 12. The access system (300,400) of claim 1 wherein the access system (300,400) is converted from the open

position to the closed position by rotating the obturator (360,460) relative to the cannula (430).

13. The access system (300,400) of claim 3 wherein the fluid flow seal (340, 440) subtends the same or similar angle as angled tip (332, 432).

14. The access system (300,400) of claim 1 wherein the obturator (460) includes a plurality of proximal openings (472a), a plurality of distal openings (472b) and a plurality of optional intermediate openings (472c).

Patentansprüche

1. Ein chirurgisches Insufflationszugangssystem (300, 400), das Folgendes beinhaltet:

einen Trokar (310, 410), der Folgendes beinhaltet:

ein proximales Ende und ein distales Ende; eine Trokardichtungsbaugruppe (420), die am proximalen Ende des Trokars (110) angeordnet ist, wobei die Trokardichtungsbaugruppe (420) eine Instrumentendichtung beinhaltet;

eine längliche Kanüle (430), die am distalen Ende des Trokars angeordnet ist, wobei die Kanüle (430) eine röhrenförmige Wand, die ein Lumen (334, 434) definiert, ein offenes proximales Ende, und ein offenes distales Ende beinhaltet;

einen Zugangskanal, der eine Längsachse definiert, die sich durch die Trokardichtungsbaugruppe (420) und das Lumen (334, 434) der Kanüle (430), von dem proximalen Ende des Trokars bis zu dem distalen Ende des Trokars, erstreckt;

eine Fluidöffnung (350, 450), die an dem proximalen Ende des Trokars angeordnet ist; und

eine Fluidflussdichtung (340, 440), die in dem Zugangskanal angeordnet ist;

wobei das System ferner einen Obturator (360, 460) beinhaltet, der Folgendes beinhaltet:

einen länglichen Hauptteil (362, 462), der ein proximales Ende und ein distales Ende beinhaltet;

mindestens eine proximale Öffnung (372) und mindestens eine distale Öffnung (374), die den länglichen Hauptteil (362) durchdringen;

eine gewebedurchdringende Spitze, die an dem distalen Ende angeordnet ist und wobei mindestens ein Anteil der Spitze des Obturators (360, 460) transparent ist;

einen Instrumentenschacht (368), der an einem proximalen Ende des Obturators (360, 460) offen ist, sich längs durch den Hauptteil (362, 462) des Obturators (360, 460) erstreckt, an der Spitze des Obturators endet und zum Aufnehmen eines Laparoscops darin dimensioniert ist; und einen Handgriff, der an dem proximalen Ende angeordnet ist,

wobei der Obturator (360, 460) gleitfähig in ein proximales Ende des Zugangskanals einführbar ist und die Spitze des Obturators (360, 460) sich aus dem distalen, offenen Ende der Kanüle (430) erstreckt, wenn er vollständig durch sie eingeführt ist; und einen Fluidflusskanal (480), der in fluidier Verbindung mit der Fluidöffnung (350, 450) des Trokars steht, den Instrumentenschacht (368) einschließt und sich bis zu einem distalen Ende des Insufflationszugangssystems (300, 400) erstreckt und die mindestens eine proximale Öffnung (372) und die mindestens eine distale Öffnung (374), die in dem Hauptteil des Obturators angeordnet sind, beinhaltet,

wobei der Obturator (360, 460) in dem Zugangskanal Folgendes aufweist: eine geschlossene Position, in welcher der Hauptteil (362, 462) des Obturators (360, 460) in dichtendem Kontakt mit der Fluidflussdichtung (340, 440) steht, wodurch der Fluidfluss durch den Fluidflusskanal (480) verhindert wird, und eine offene Position, in welcher der Hauptteil (362, 462) des Obturators (360, 460) nicht in dichtendem Kontakt mit der Fluidflussdichtung (340, 440) steht, wodurch der Fluidfluss durch den Fluidflusskanal (480) gestattet wird,

wobei die distale Öffnung (374) in der offenen Position exponiert ist und die distale Öffnung (374) in der geschlossenen Position proximal zu der Fluidflussdichtung (340) positioniert ist, die eine Dichtung mit einem Anteil des länglichen Hauptteils (362) des Obturators (360, 460) distal zu der distalen Öffnung (374) bildet, wodurch der Fluidfluss verhindert wird.

2. Das Zugangssystem (300, 400) gemäß Anspruch 1, wobei die Trokardichtungsbaugruppe (120) ferner eine Nulldichtung beinhaltet.
3. Das Zugangssystem (300, 400) gemäß Anspruch 1, wobei das distale Ende der Kanüle (430) eine angewinkelte Spitze (332, 432) beinhaltet.
4. Das Zugangssystem (300, 400) gemäß Anspruch 1, wobei die Fluidöffnung (350, 450) auf der Trokardichtungsbaugruppe (420) angeordnet ist.
5. Das Zugangssystem (300, 400) gemäß Anspruch 1, wobei die Fluidflussdichtung (340, 440) mit einer Kanülenspitze (332, 432) integriert ist, die an dem distalen Ende der Kanüle (430) angeordnet ist.

6. Das Zugangssystem (300, 400) gemäß Anspruch 1, wobei die Fluidflussdichtung (340, 440) proximal zu dem distalen Ende der Kanüle (430) angeordnet ist.
7. Das Zugangssystem (300, 400) gemäß Anspruch 1, wobei die Fluidflussdichtung (340, 440) eine Vielzahl von Unterdichtungen beinhaltet.
8. Das Zugangssystem (300, 400) gemäß Anspruch 1, wobei der Fluidflusskanal (480) einen Raum beinhaltet, der durch das Lumen (334, 434) der Kanüle (430) und den Hauptteil (362, 462) des Obturators (360, 460) definiert ist.
9. Das Zugangssystem (300, 400) gemäß Anspruch 1, wobei der Fluidflusskanal (480) eine oder mehrere Längskerben beinhaltet, die an einer inneren Wand der Kanüle (430) angeordnet sind.
10. Das Zugangssystem (300, 400) gemäß Anspruch 1, wobei die Fluidflussdichtung (340, 440) nicht senkrecht zu der Längsachse des Zugangskanals steht.
11. Das Zugangssystem (300, 400) gemäß Anspruch 1, wobei der Obturator (360, 460) von einer offenen Position in eine geschlossene Position überführt wird, indem der Obturator (360) längs zum proximalen Ende hin zurückgezogen wird, um die mindestens eine distale Öffnung (374) proximal zu der Fluidflussdichtung (340) zu positionieren.
12. Das Zugangssystem (300, 400) gemäß Anspruch 1, wobei das Zugangssystem (300, 400) von der offenen Position in die geschlossene Position überführt wird, indem der Obturator (360, 460) relativ zu der Kanüle (430) gedreht wird.
13. Das Zugangssystem (300, 400) gemäß Anspruch 3, wobei die Fluidflussdichtung (340, 440) den gleichen Winkel oder einen ähnlichen Winkel begrenzt wie die angewinkelte Spitze (332, 432).
14. Das Zugangssystem (300, 400) gemäß Anspruch 1, wobei der Obturator (460) eine Vielzahl von proximalen Öffnungen (472a), eine Vielzahl von distalen Öffnungen (472b) und eine Vielzahl von Zwischenöffnungen (472c) einschließt.

50 Revendications

1. Système d'accès chirurgical d'insufflation (300, 400) comportant :
 - un trocart (310, 410) comportant :
 - une extrémité proximale et une extrémité distale ;

un ensemble joint d'étanchéité de trocart (420) disposé au niveau de l'extrémité proximale du trocart (110), l'ensemble joint d'étanchéité de trocart (420) comportant un joint d'étanchéité d'instrument ;
 une canule oblongue (430) disposée au niveau de l'extrémité distale du trocart, la canule (430) comportant une paroi tubulaire délimitant une lumière (334, 434), une extrémité proximale ouverte, et une extrémité distale ouverte ;
 un canal d'accès délimitant un axe longitudinal, qui s'étend à travers l'ensemble joint d'étanchéité de trocart (420) et la lumière (334, 434) de la canule (430), de l'extrémité proximale du trocart à l'extrémité distale du trocart ;
 un orifice pour fluide (350, 450) disposé au niveau de l'extrémité proximale du trocart ;
 et
 un joint d'étanchéité d'écoulement de fluide (340, 440) disposé dans le canal d'accès ;

le système comportant en outre un obturateur (360, 460) comportant :

un corps oblong (362, 462) comportant une extrémité proximale et une extrémité distale ;
 au moins une ouverture proximale (372) et au moins une ouverture distale (374) perforant le corps oblong (362) ;
 une pointe de pénétration des tissus disposée au niveau de l'extrémité distale, au moins une partie de la pointe de l'obturateur (360, 460) étant transparente ;
 un puits d'instrument (368) ouvert au niveau d'une extrémité proximale de l'obturateur (360, 460), qui s'étend longitudinalement à travers le corps (362, 462) de l'obturateur (360, 460), se terminant au niveau de la pointe de l'obturateur, et dimensionné pour y recevoir un laparoscope ;
 et
 une poignée disposée au niveau de l'extrémité proximale,

dans lequel l'obturateur (360, 460) peut être inséré de manière coulissante dans une extrémité proximale du canal d'accès, et la pointe de l'obturateur (360, 460) s'étend hors de l'extrémité distale ouverte de la canule (430) lorsqu'il est entièrement inséré dans celle-ci ; et

un canal d'écoulement de fluide (480) relié de manière fluidique à l'orifice pour fluide (350, 450) du trocart, comprenant le puits d'instrument (368) et s'étendant jusqu'à une extrémité distale du système d'accès d'insufflation (300, 400), et comportant ladite au moins une ouverture proximale (372) et ladite au moins une ouverture distale (374) disposées dans

le corps de l'obturateur,
 dans lequel l'obturateur (360, 460) dans le canal d'accès a
 une position fermée, dans laquelle le corps (362, 462) de l'obturateur (360, 460) vient en contact de manière étanche avec le joint d'étanchéité d'écoulement de fluide (340, 440), empêchant ainsi l'écoulement de fluide dans le canal d'écoulement de fluide (480), et
 une position ouverte, dans laquelle le corps (362, 462) de l'obturateur (360, 460) ne vient pas en contact de manière étanche avec le joint d'étanchéité d'écoulement de fluide (340, 440), permettant ainsi l'écoulement de fluide dans le canal d'écoulement de fluide (480),
 dans lequel dans la position ouverte, l'ouverture distale (374) est exposée et, dans la position fermée, l'ouverture distale (374) est positionnée proximale-ment par rapport au joint d'étanchéité d'écoulement de fluide (340) qui forme un joint d'étanchéité avec une partie du corps oblong (362) de l'obturateur (360, 460) distalement par rapport à l'ouverture distale (374), empêchant ainsi l'écoulement de fluide.

- 25 2. Système d'accès (300, 400) selon la revendication 1 dans lequel l'ensemble joint d'étanchéité de trocart (120) comporte en outre un joint d'étanchéité zéro.
- 30 3. Système d'accès (300, 400) selon la revendication 1 dans lequel l'extrémité distale de la canule (430) comporte une pointe inclinée (332, 432).
- 35 4. Système d'accès (300, 400) selon la revendication 1 dans lequel l'orifice pour fluide (350, 450) est disposé sur l'ensemble joint d'étanchéité de trocart (420) .
- 40 5. Système d'accès (300, 400) selon la revendication 1 dans lequel le joint d'étanchéité d'écoulement de fluide (340, 440) est intégré à une pointe de canule (332, 432) disposée au niveau de l'extrémité distale de la canule (430).
- 45 6. Système d'accès (300, 400) selon la revendication 1 dans lequel le joint d'étanchéité d'écoulement de fluide (340, 440) est disposé de manière proximale par rapport à l'extrémité distale de la canule (430).
- 50 7. Système d'accès (300, 400) selon la revendication 1 dans lequel le joint d'étanchéité d'écoulement de fluide (340, 440) comporte un pluralité de sous-joints d'étanchéité.
- 55 8. Système d'accès (300, 400) selon la revendication 1 dans lequel le canal (480) d'écoulement de fluide comporte un espace délimité par la lumière (334, 434) de la canule (430) et le corps (362, 462) de l'obturateur (360, 460).

9. Système d'accès (300, 400) selon la revendication 1 dans lequel le canal (480) d'écoulement de fluide comporte une ou plusieurs rainures longitudinales disposées sur une paroi interne de la canule (430). 5
10. Système d'accès (300, 400) selon la revendication 1 dans lequel le joint d'étanchéité d'écoulement de fluide (340, 440) n'est pas perpendiculaire à l'axe longitudinal du canal d'accès. 10
11. Système d'accès (300, 400) selon la revendication 1 dans lequel l'obturateur (360, 460) est changé d'une position ouverte à une position fermée en retirant l'obturateur (360) longitudinalement en direction de l'extrémité proximale pour positionner ladite au moins une ouverture distale (374) proximale par rapport au joint d'étanchéité d'écoulement de fluide (340). 15
12. Système d'accès (300, 400) selon la revendication 1 dans lequel le système d'accès (300, 400) est changé de la position ouverte à la position fermée en tournant l'obturateur (360, 460) par rapport à la canule (430). 20
13. Système d'accès (300, 400) selon la revendication 3 dans lequel le joint d'étanchéité d'écoulement de fluide (340, 440) sous-tend le même angle que la pointe inclinée (332, 432) ou un angle similaire. 25
14. Système d'accès (300, 400) selon la revendication 1 dans lequel l'obturateur (460) comprend une pluralité d'ouvertures proximales (472a), une pluralité d'ouvertures distales (472b) et une pluralité d'ouvertures intermédiaires éventuelles (472c). 30
- 35

40

45

50

55

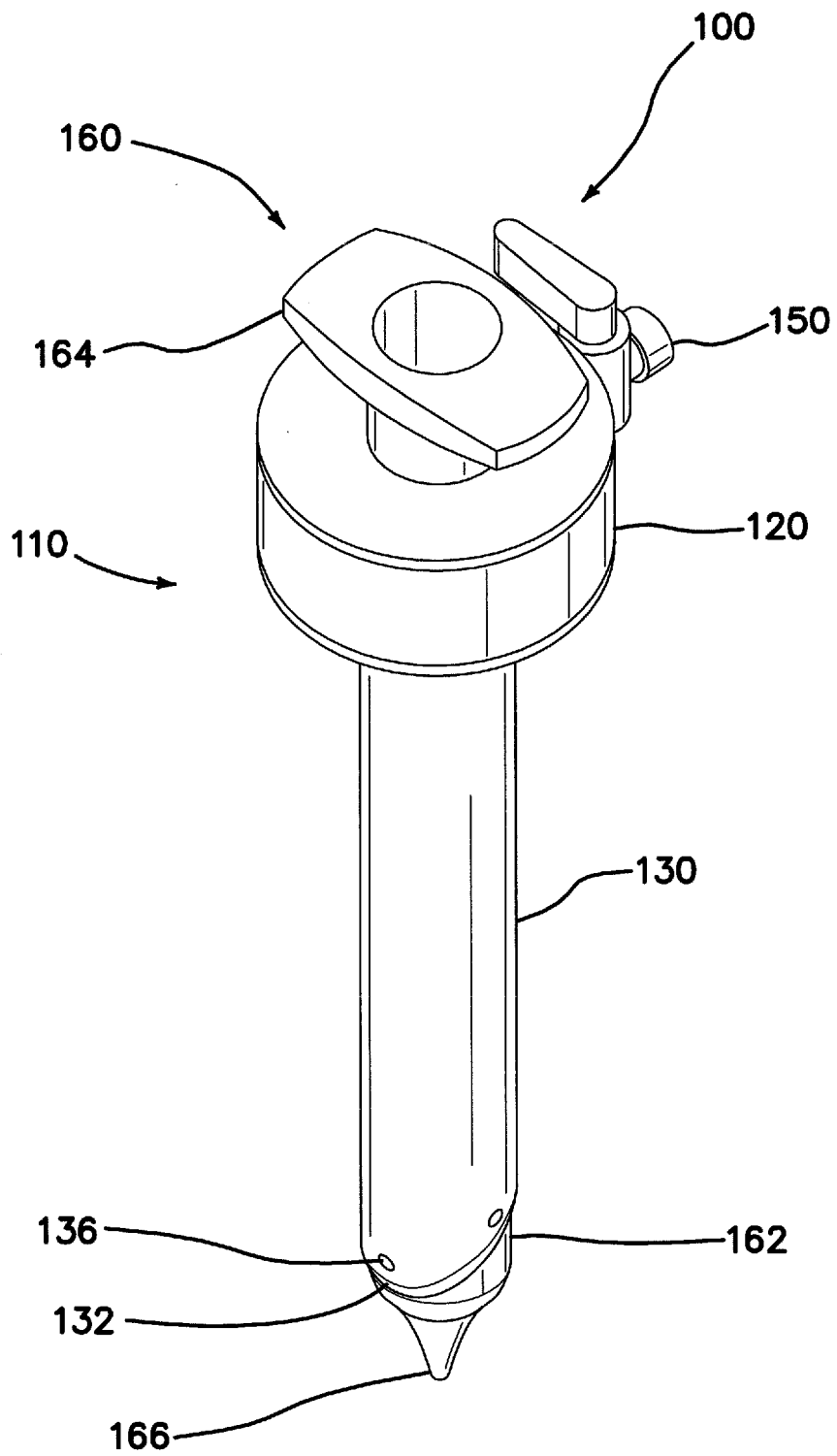
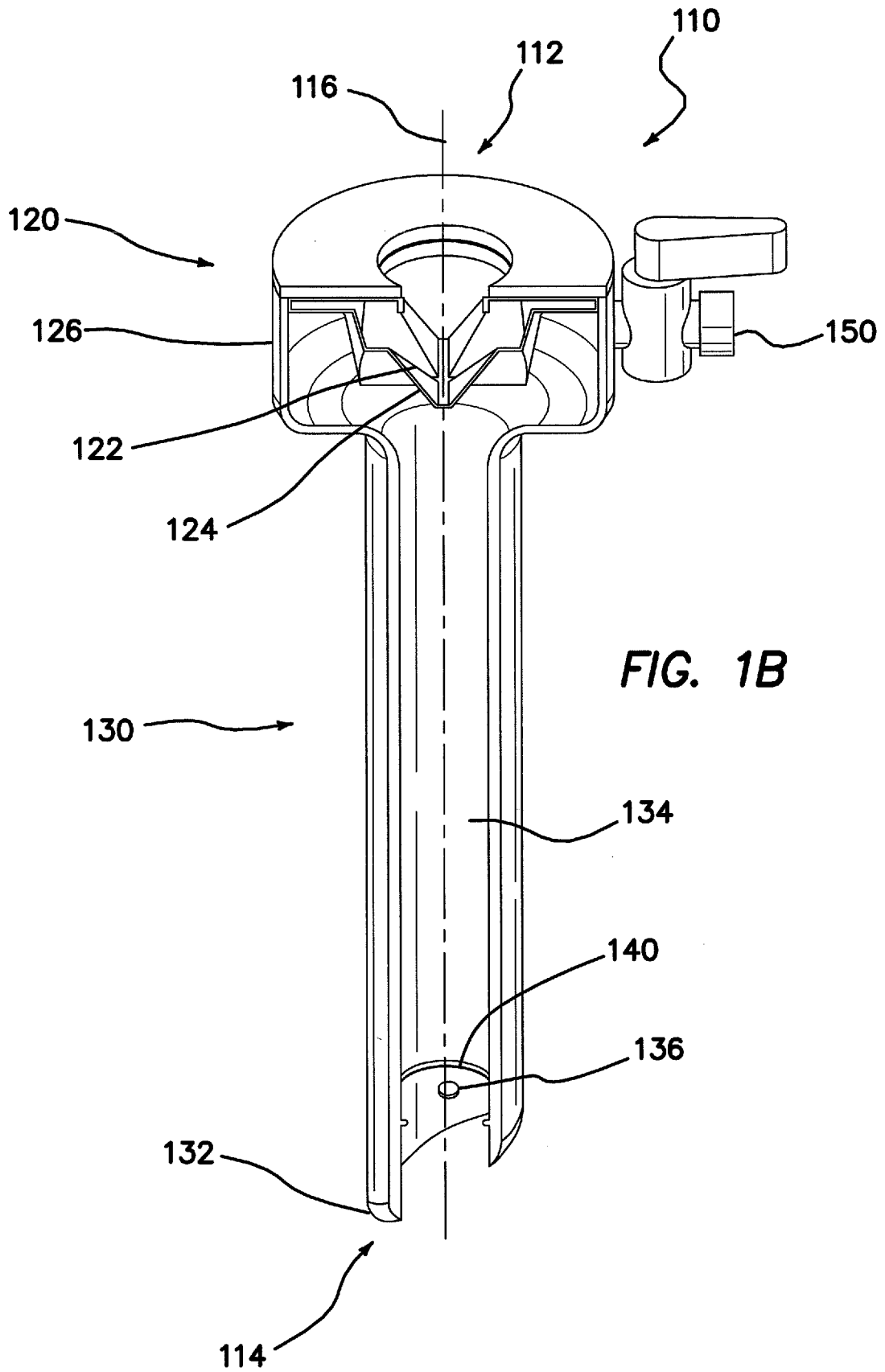

FIG. 1A



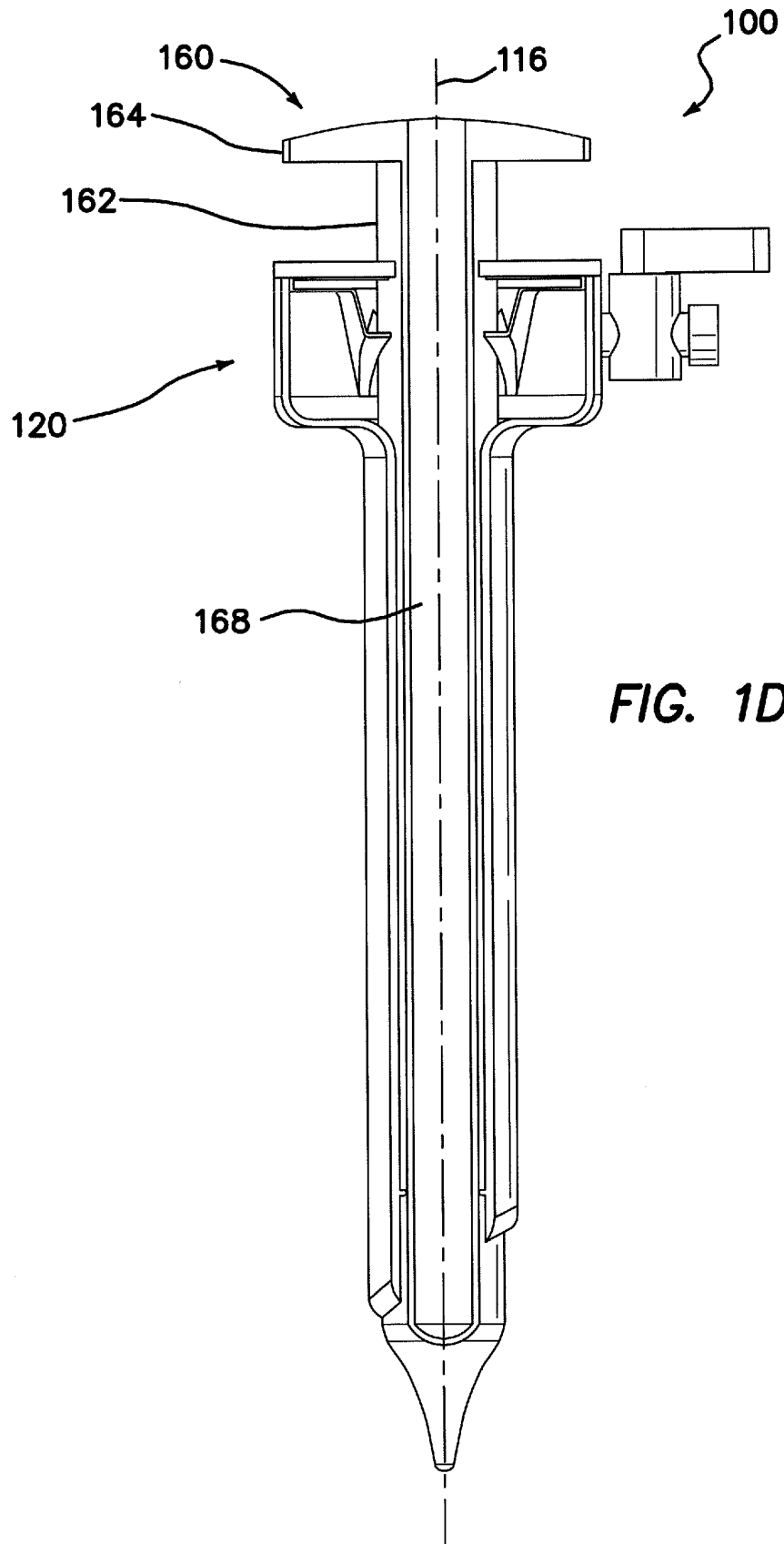

FIG. 1D

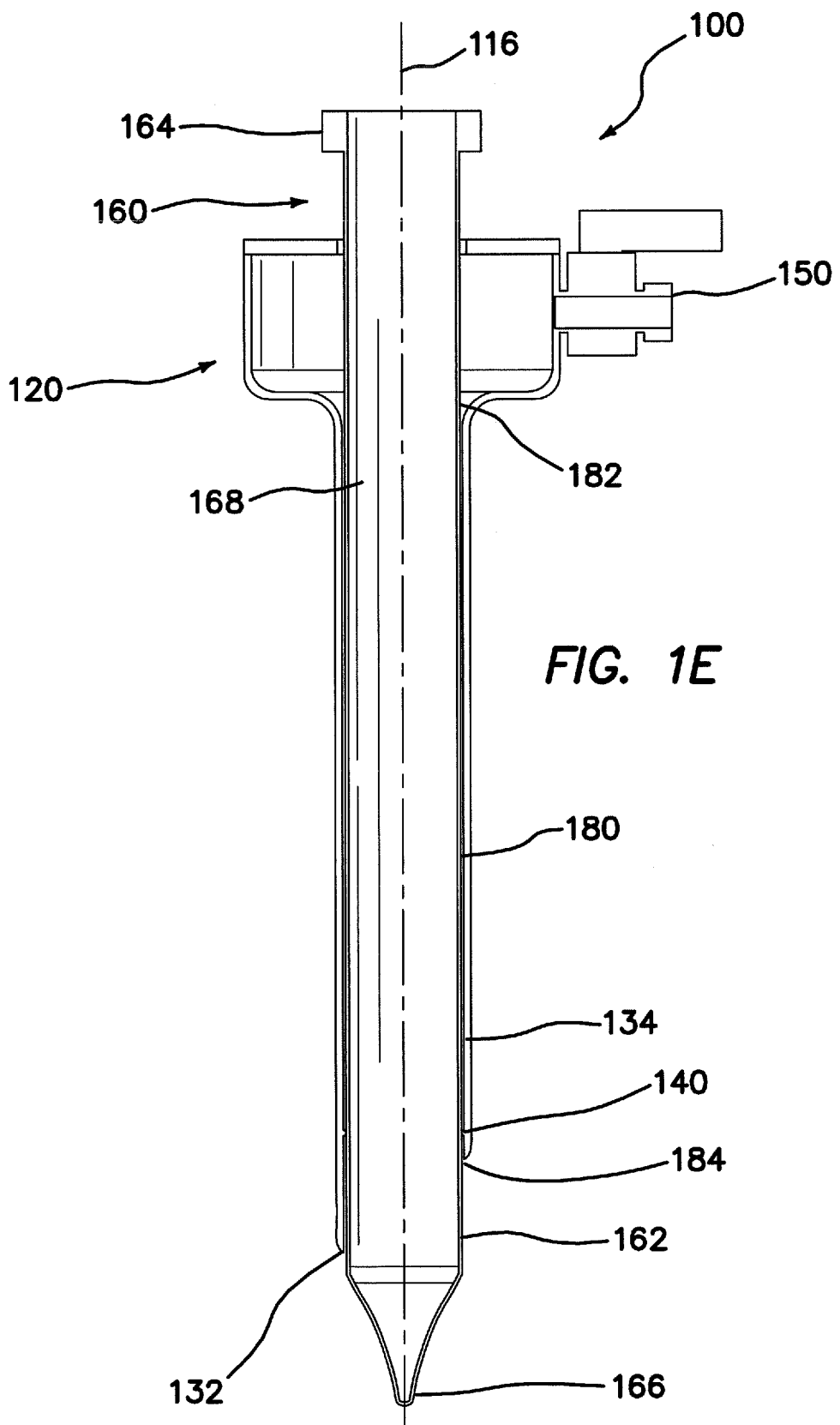

FIG. 1E

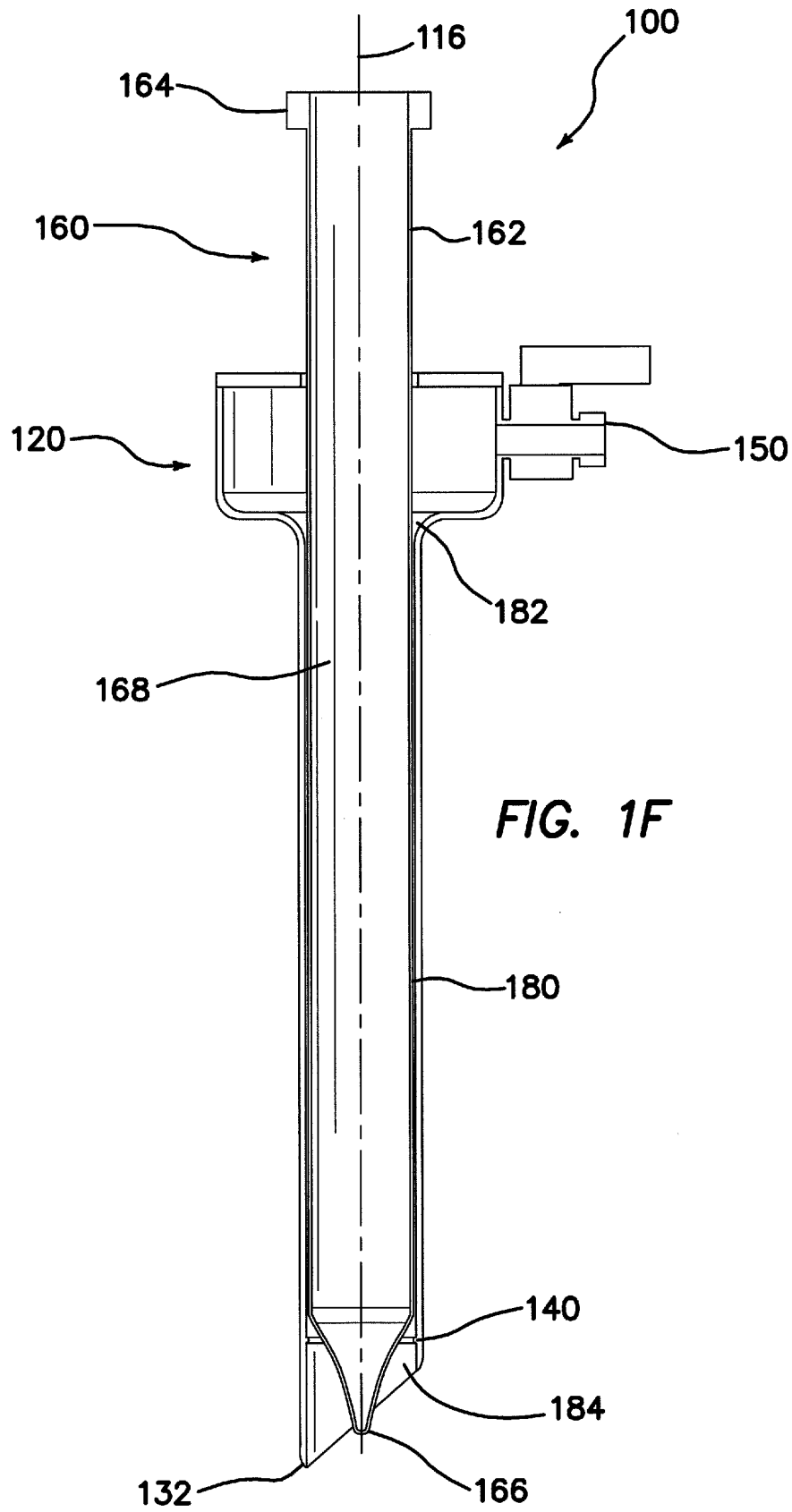
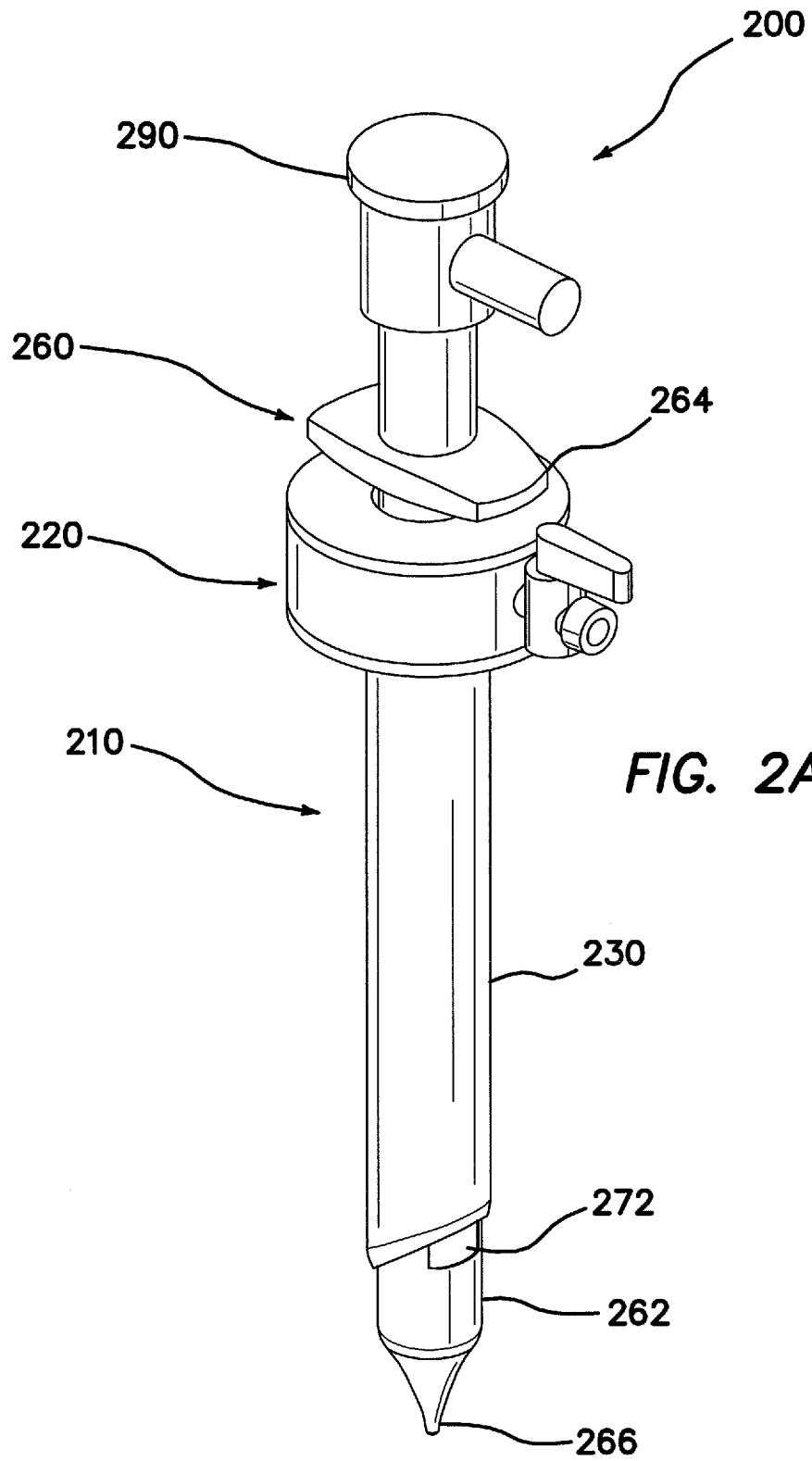

FIG. 1F



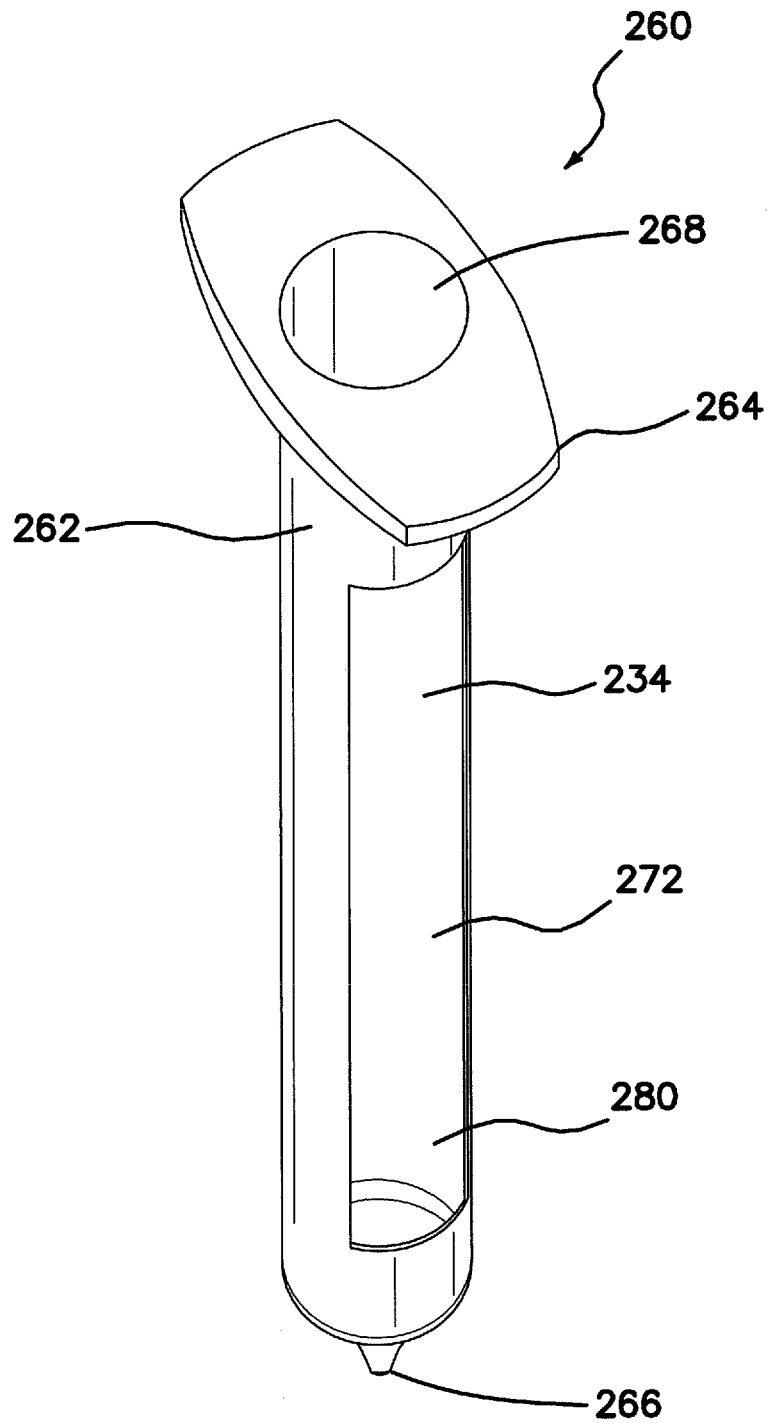

FIG. 2B

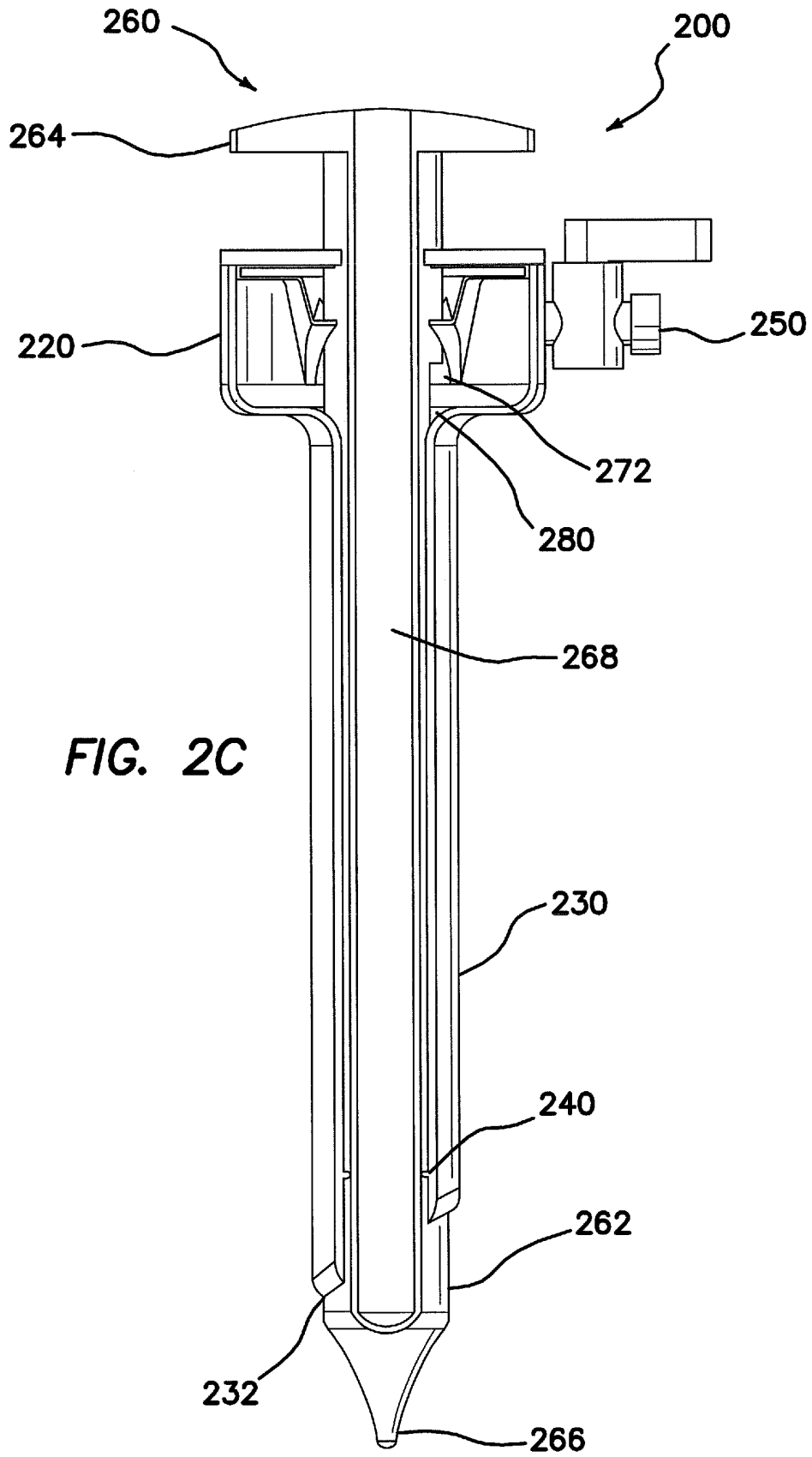
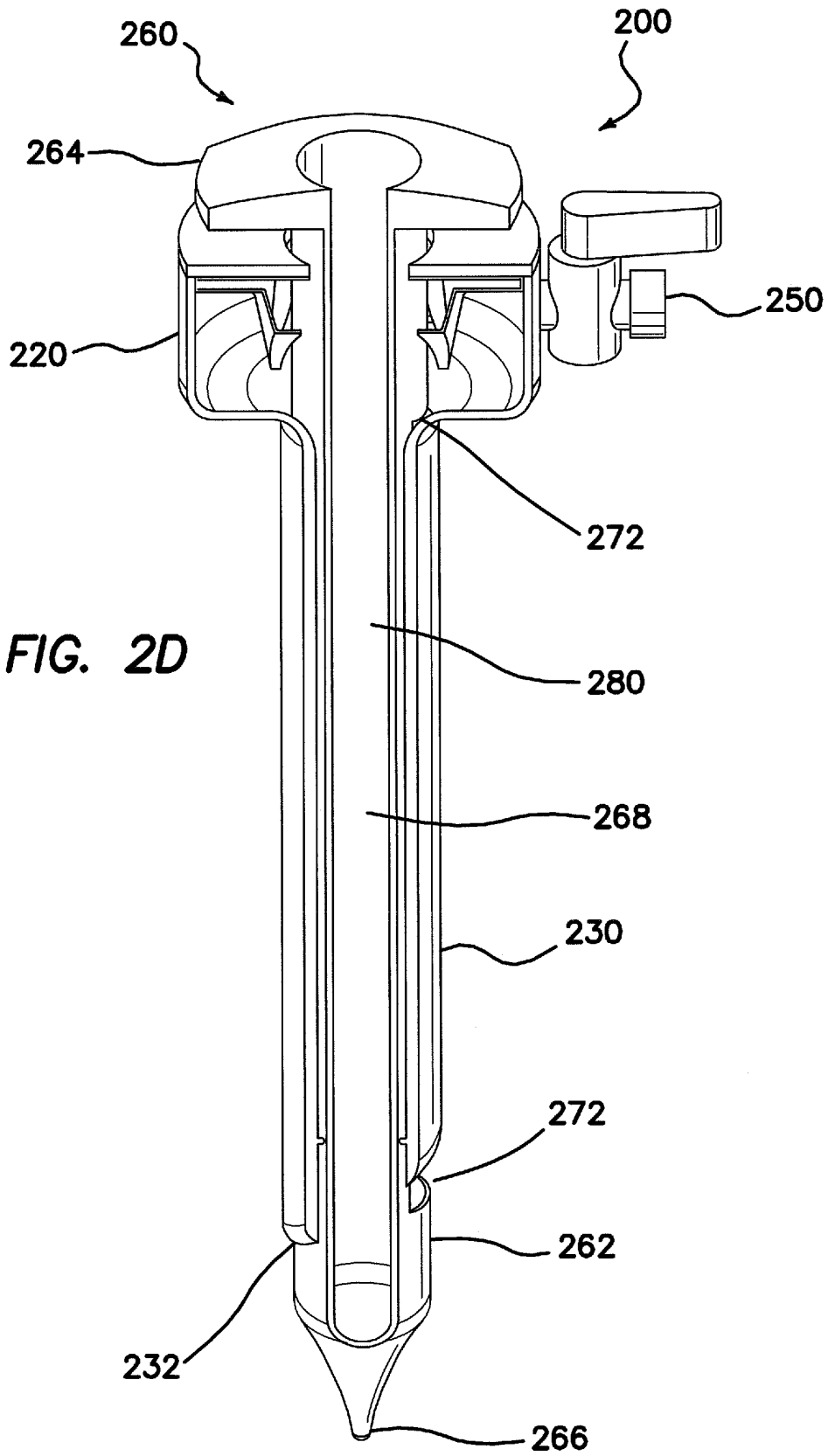
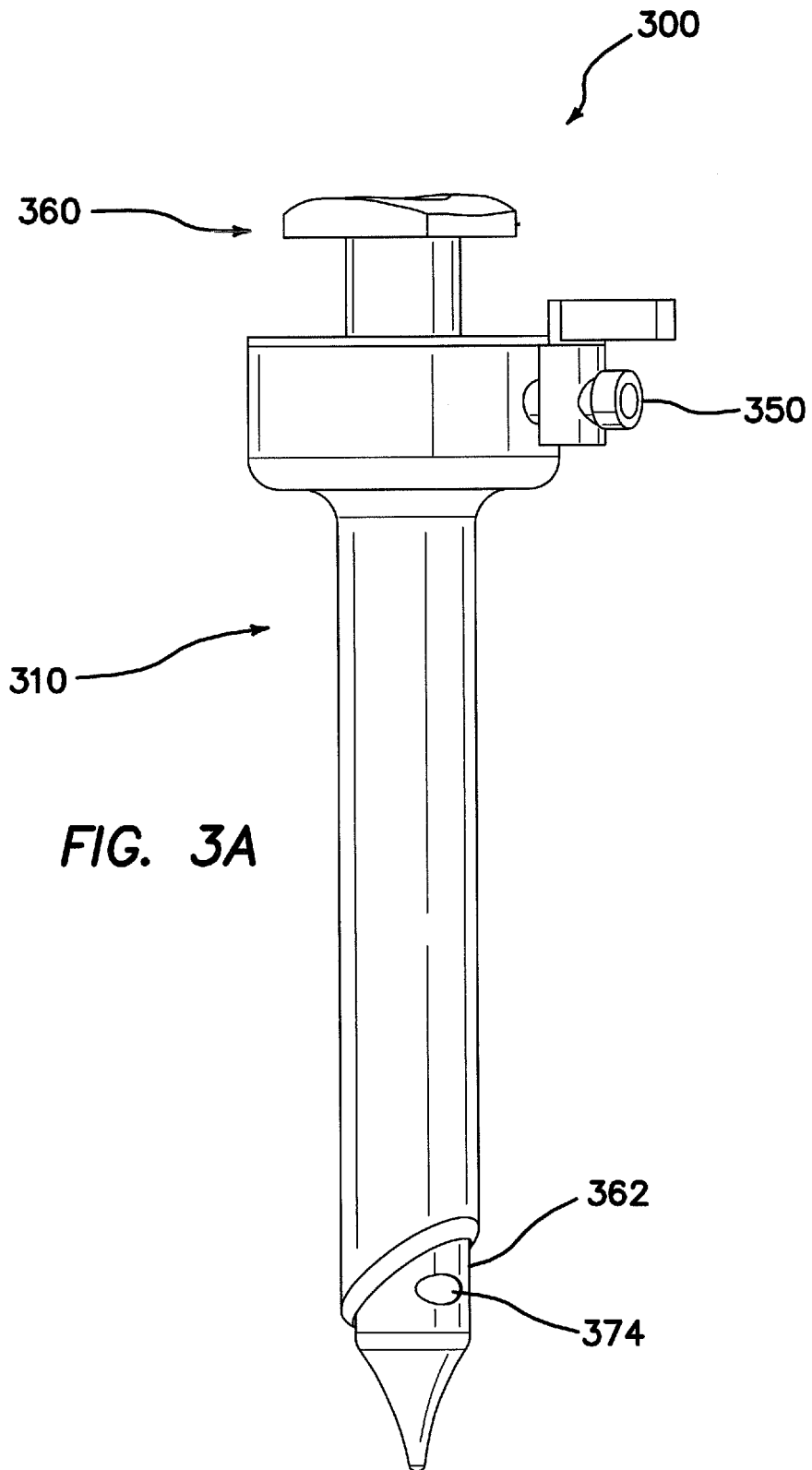

FIG. 2C





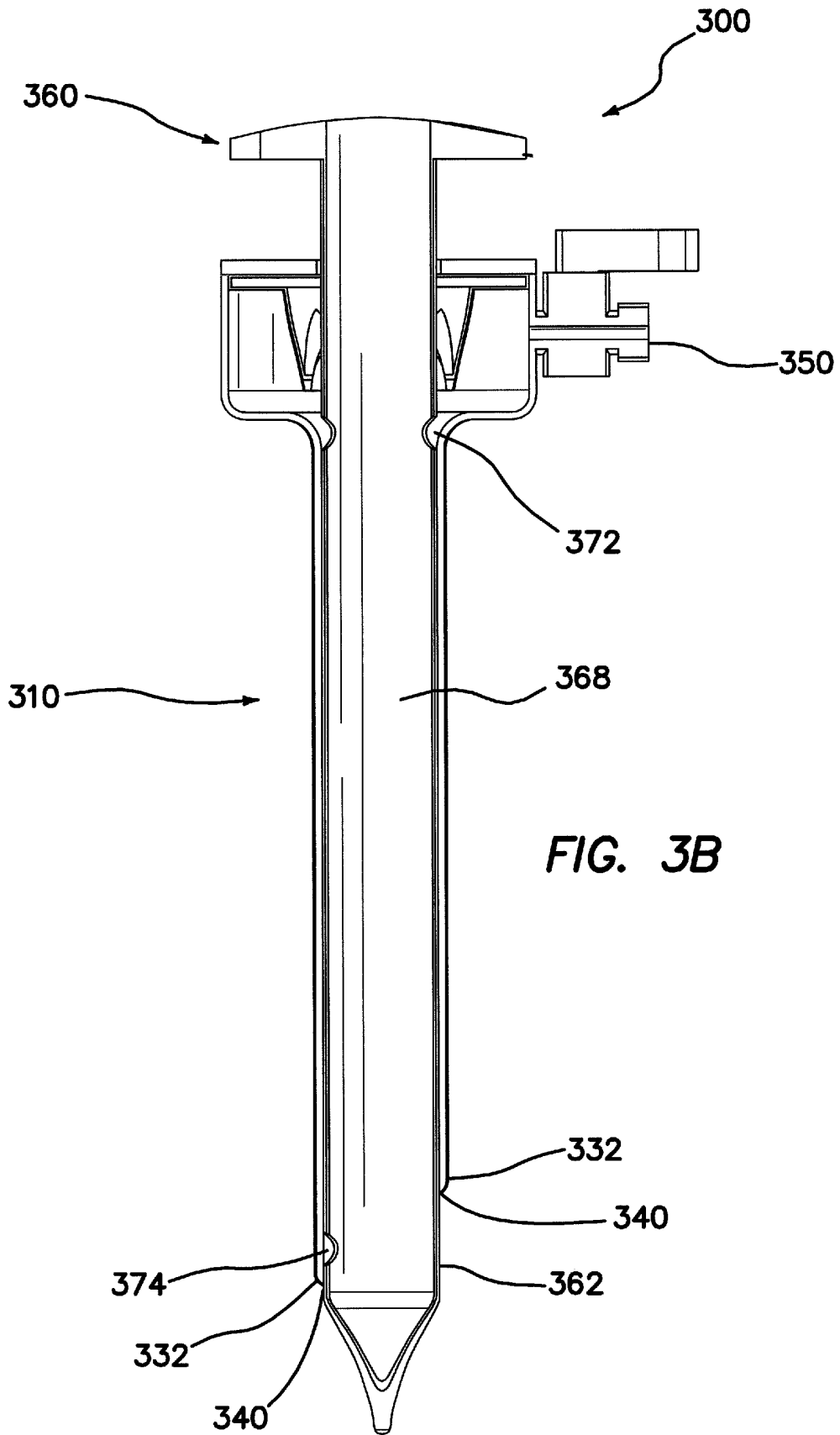
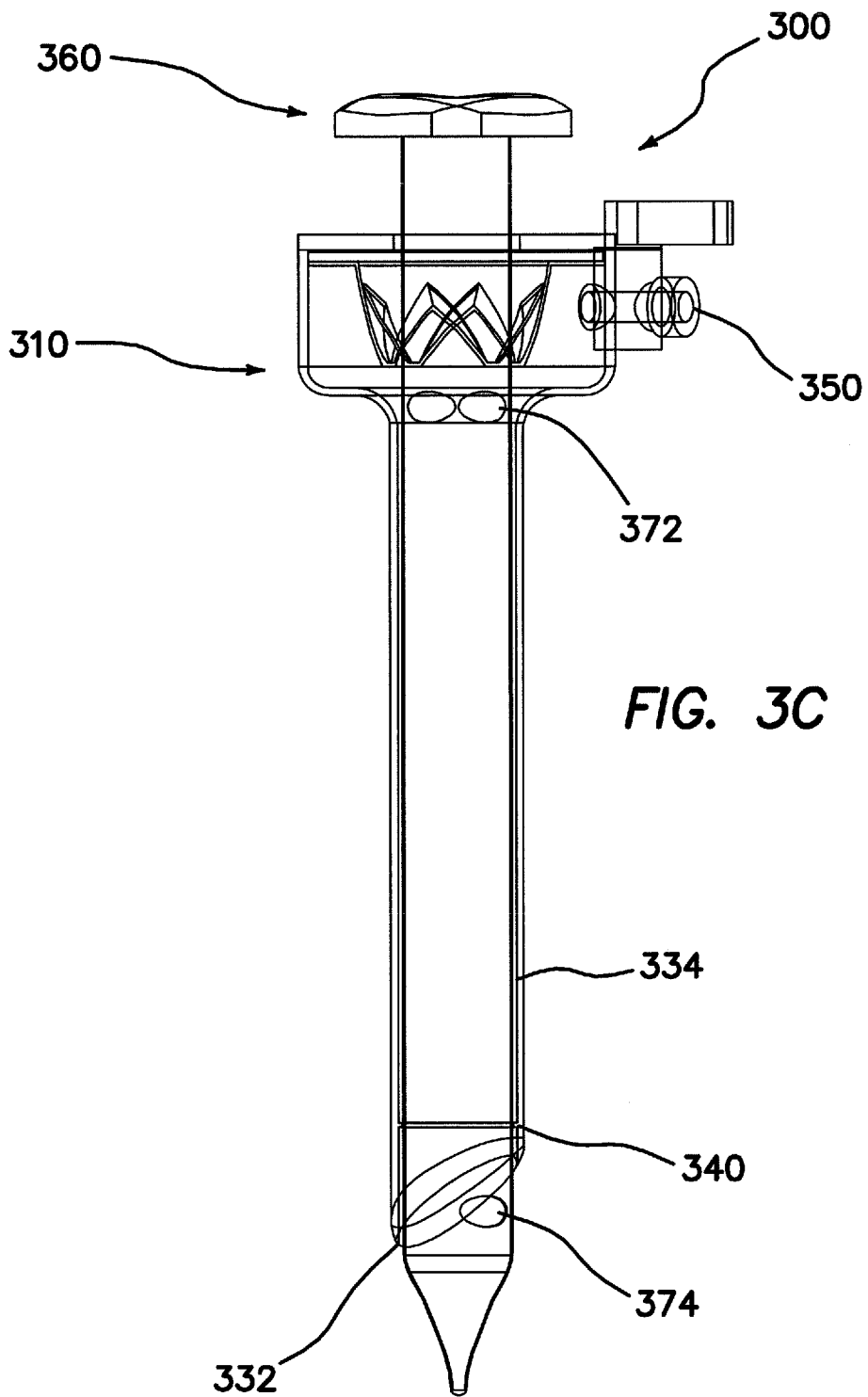

FIG. 3B



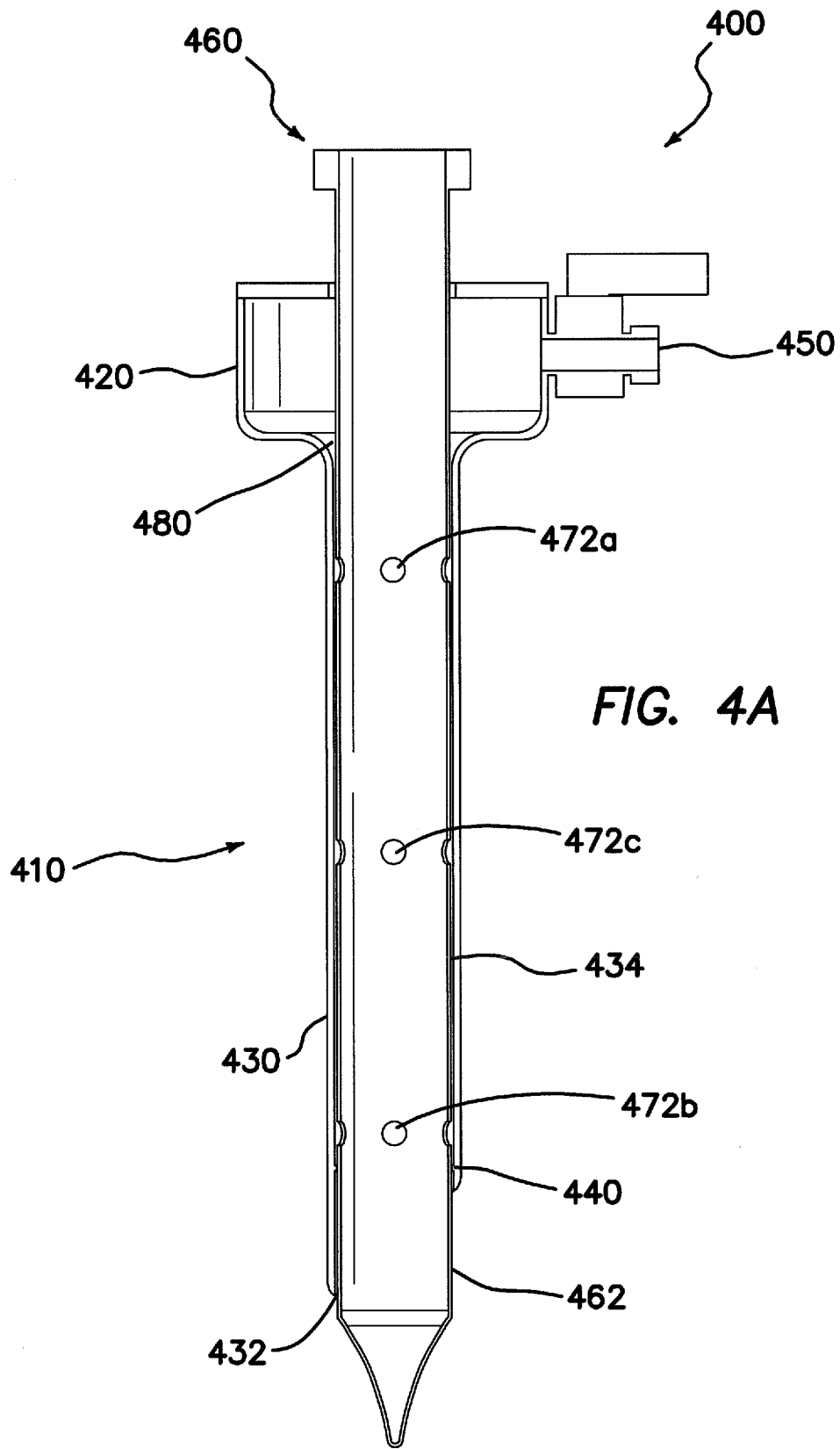
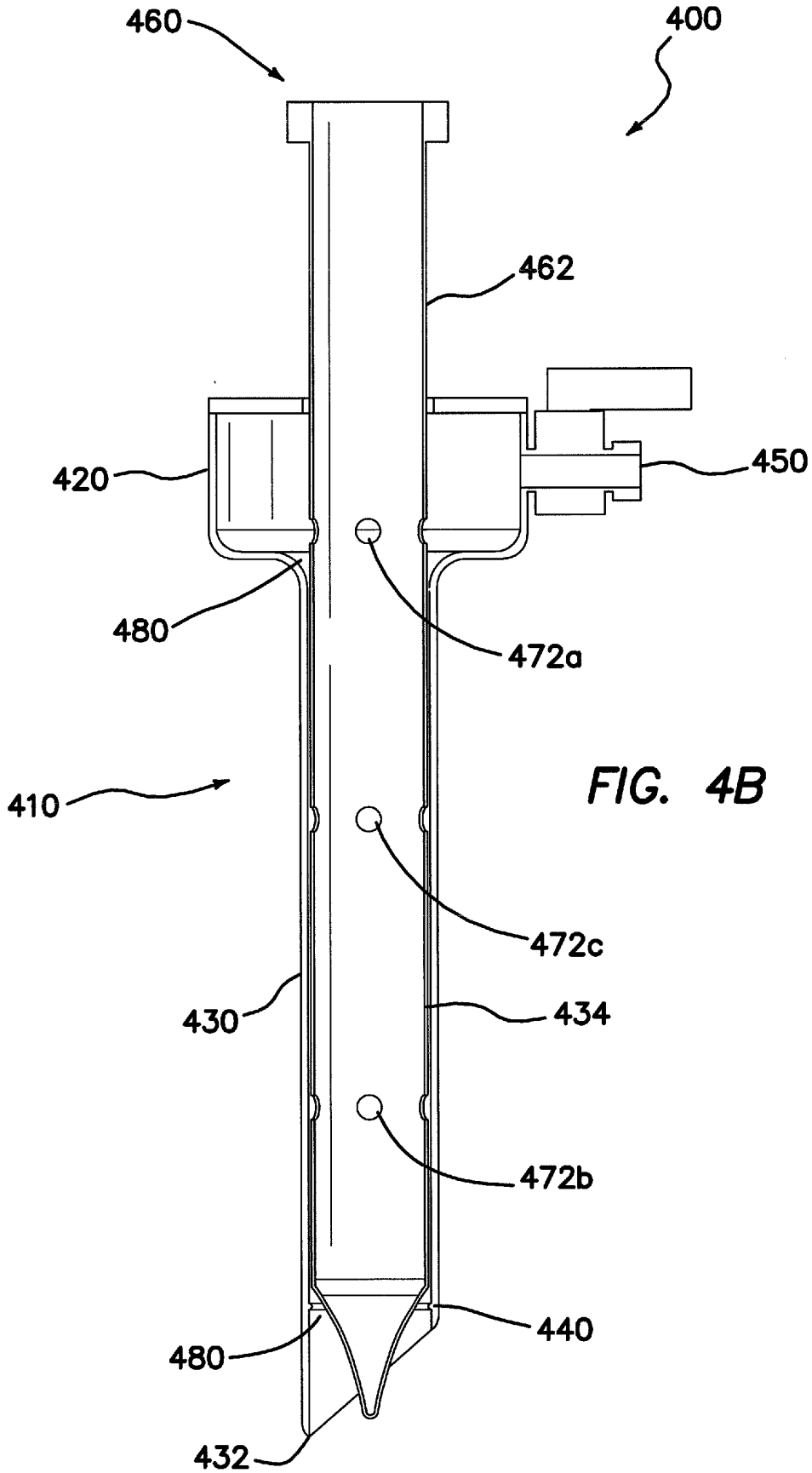
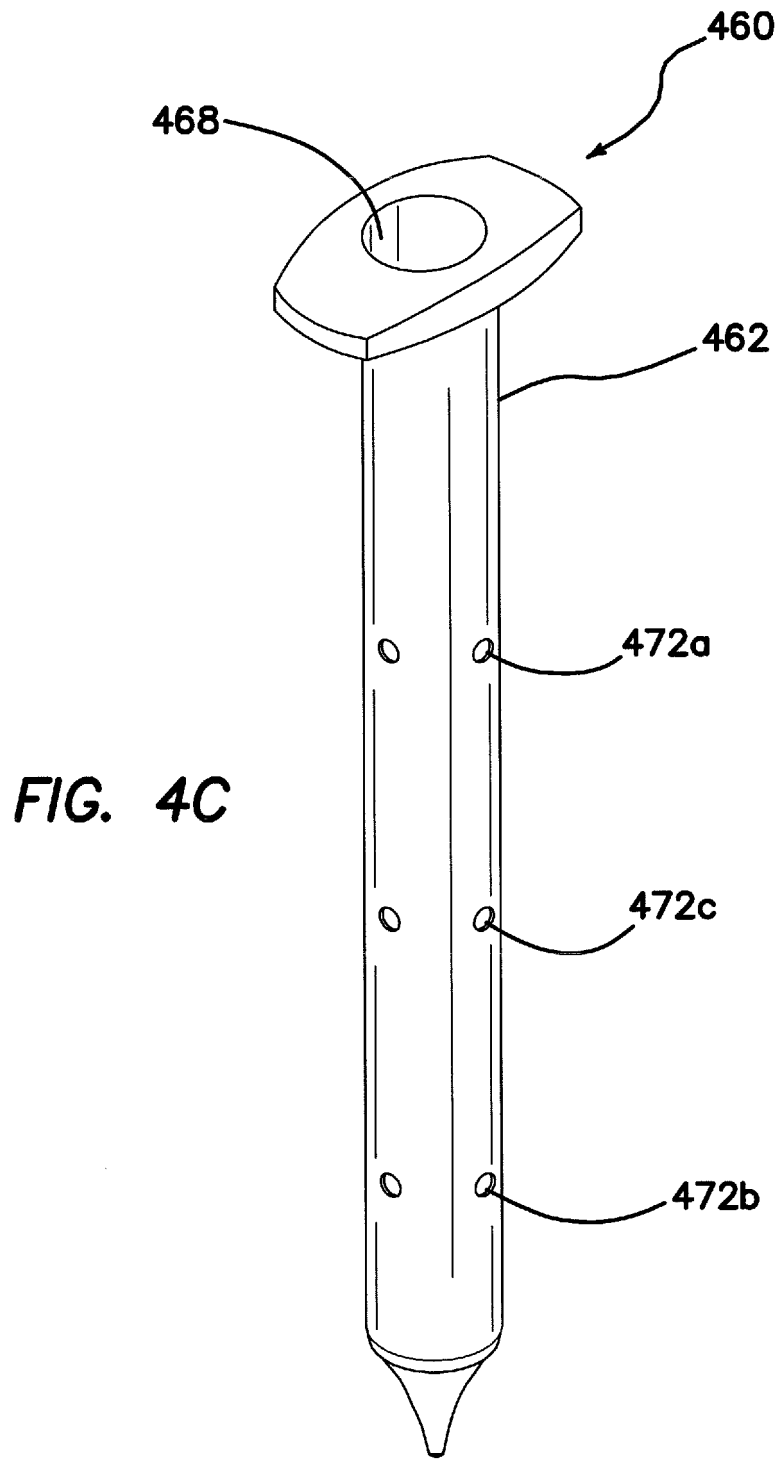

FIG. 4A





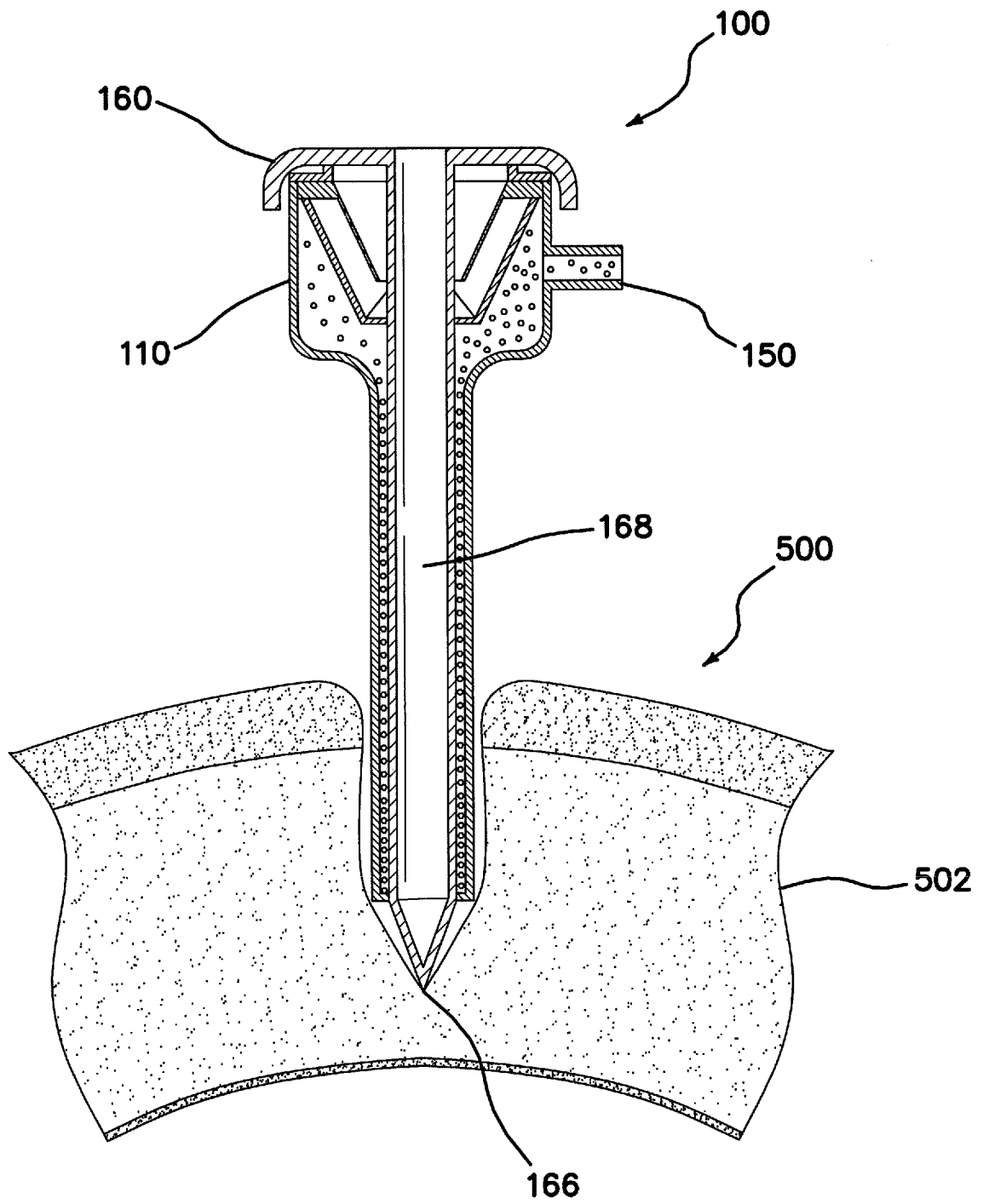

FIG. 5A

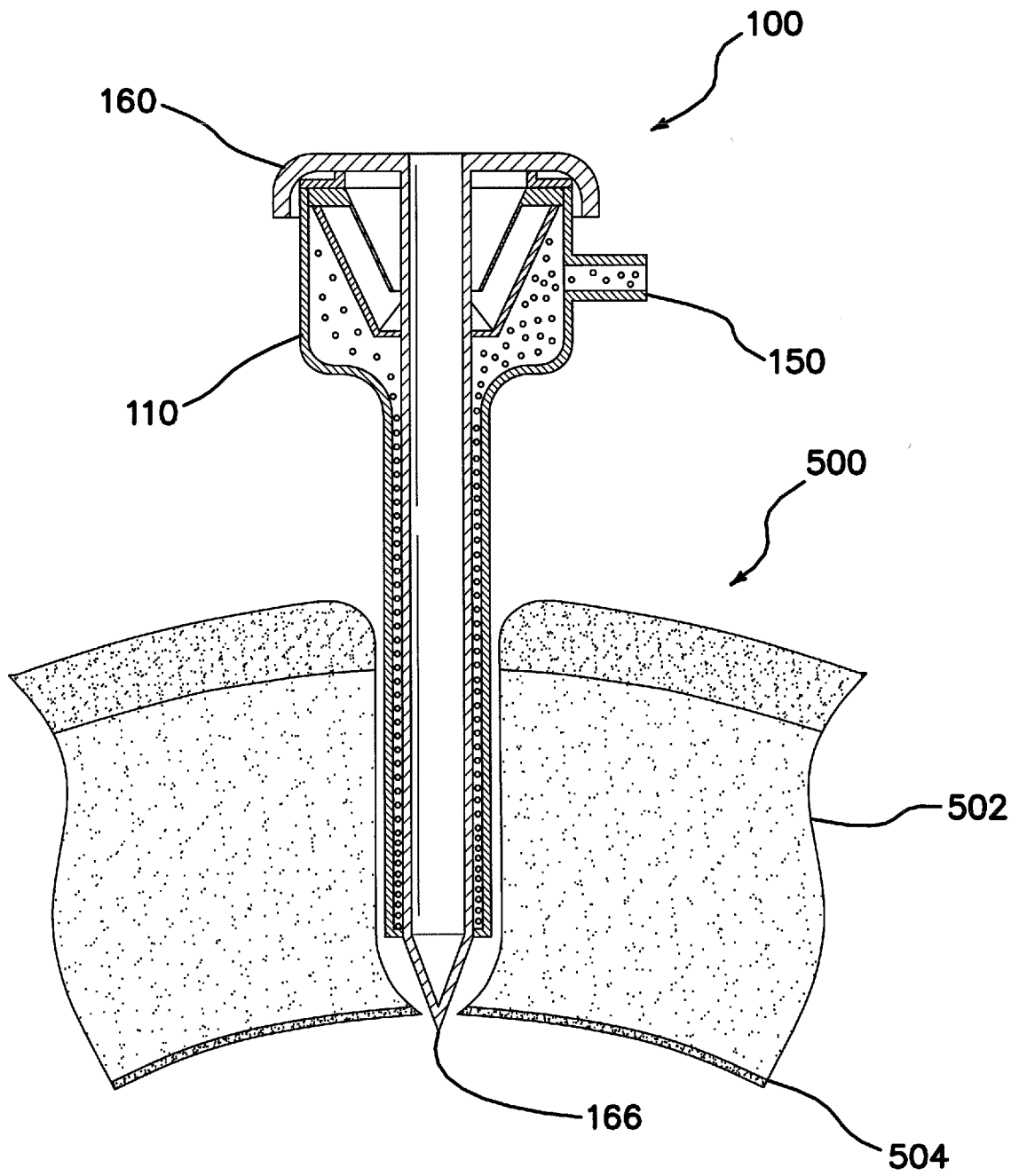

FIG. 5B

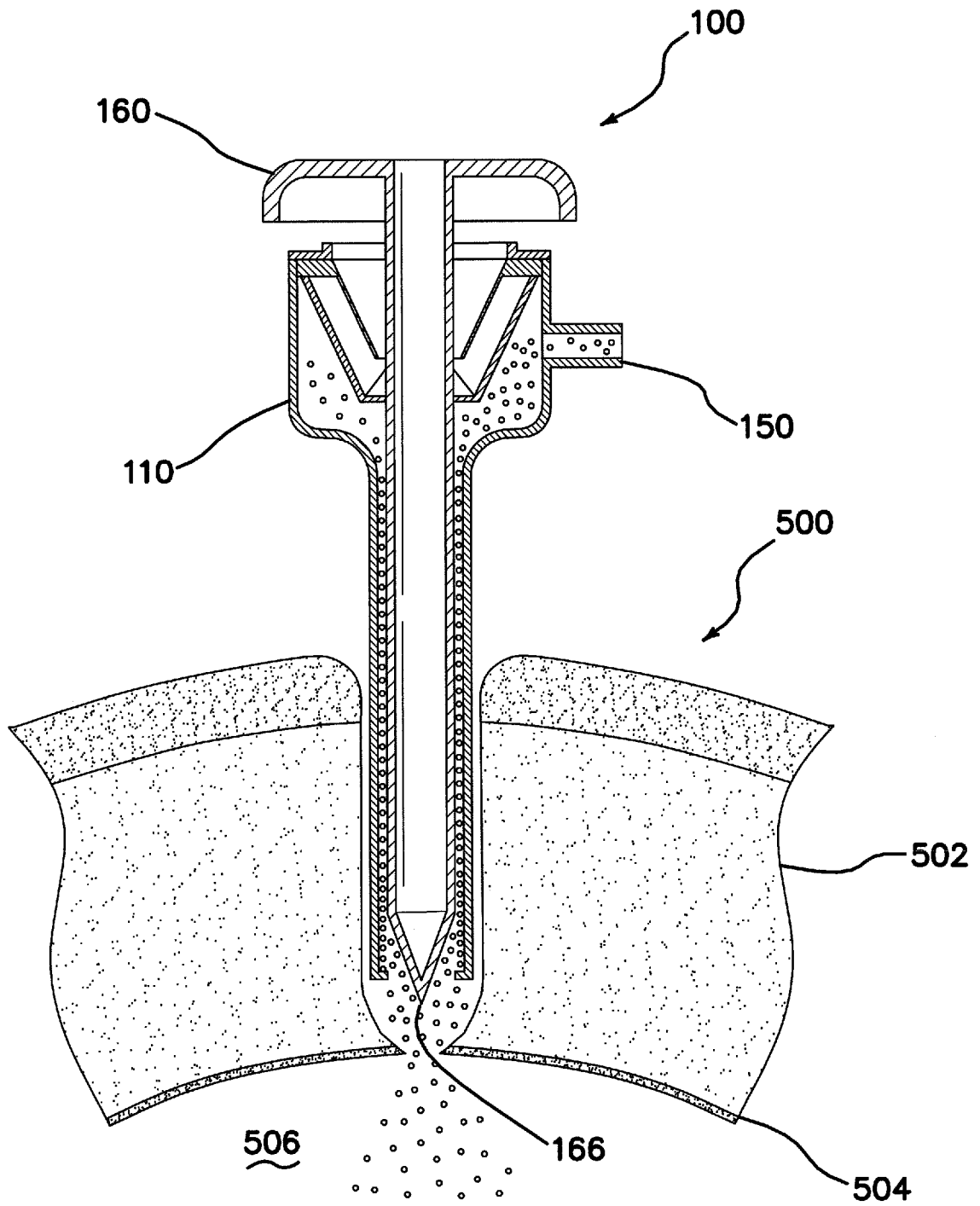

FIG. 5C

REFERENCES CITED IN THE DESCRIPTION

This list of references cited by the applicant is for the reader's convenience only. It does not form part of the European patent document. Even though great care has been taken in compiling the references, errors or omissions cannot be excluded and the EPO disclaims all liability in this regard.

Patent documents cited in the description

- EP 1733707 A1 [0007]
- US 2005288622 A1 [0007]
- US 2005070851 A1 [0007]
- WO 03020140 A1 [0007]

专利名称(译)	填充访问系统		
公开(公告)号	EP2837345B1	公开(公告)日	2016-10-05
申请号	EP2014186927	申请日	2009-01-26
[标]申请(专利权)人(译)	应用医疗资源		
申请(专利权)人(译)	应用医疗资源CORPORATION		
当前申请(专利权)人(译)	应用医疗资源CORPORATION		
[标]发明人	ALBRECHT JEREMY J JOHNSON GARY M BRUSTAD JOHN R		
发明人	ALBRECHT, JEREMY J. JOHNSON, GARY M. BRUSTAD, JOHN R.		
IPC分类号	A61B17/34		
CPC分类号	A61M13/003 A61B17/3439 A61B17/3474 A61B2017/00907 A61B2017/3441 A61B2017/3456 A61B2017/347		
优先权	61/023539 2008-01-25 US		
其他公开文献	EP2837345A1		
外部链接	Espacenet		

摘要(译)

系统，装置和方法允许在将套管插入体腔之前绝缘体腔。进入系统的一些实施例包括填塞器（160），套管针（110）和流体流动通道（180）。进入系统具有闭合配置，其中进入系统的远端与流体流动通道流体隔离，以及打开配置，其中进入系统的远端流体连接到流体流动通道，从而允许流体流动，例如，绝缘气体进入体腔。

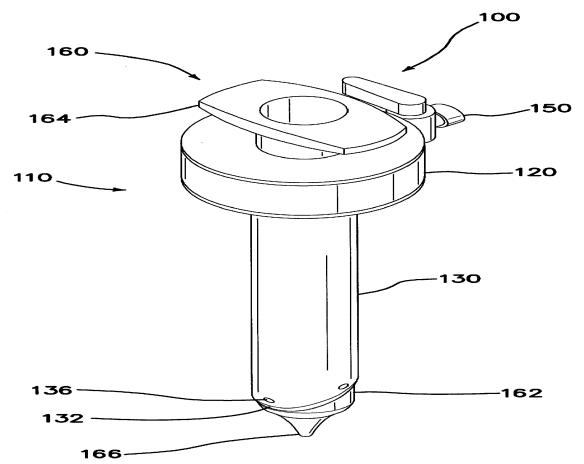

FIG. 1A