

(19)



(11)

EP 2 769 683 A2

(12)

EUROPEAN PATENT APPLICATION

(43) Date of publication:
27.08.2014 Bulletin 2014/35

(51) Int Cl.:
A61B 17/00 (2006.01) A61B 17/34 (2006.01)

(21) Application number: **14169569.2**

(22) Date of filing: **04.03.2002**

(84) Designated Contracting States:
DE FR GB

(30) Priority: **24.09.2001 US 324613 P**

(62) Document number(s) of the earlier application(s) in accordance with Art. 76 EPC:
**11191187.1 / 2 428 173
02706494.8 / 1 429 660**

(71) Applicant: **APPLIED MEDICAL RESOURCES CORPORATION**
Rancho Santa Margarita, CA 92688 (US)

(72) Inventors:
• **Pingleton, Edward D**
Rancho Santa Margarita, CA California 22782 (US)

• **Wixey, Matthew A**
Rancho Santa Margarita, CA California 22782 (US)
• **Kahle, Hank**
Rancho Santa Margarita, CA California 22782 (US)

(74) Representative: **Fitchett, Stuart Paul**
Saunders & Dolleymore LLP
9 Rickmansworth Road
Watford
Hertfordshire WD18 0JU (GB)

Remarks:
This application was filed on 23-05-2014 as a divisional application to the application mentioned under INID code 62.

(54) **Bladeless obturator**

(57) The invention is directed towards a bladeless obturator (18) for wedging through muscle fiber layers (41, 43, 45) to safely cut through to the abdominal cavity (32) in order to apply a cannula (12). The invention comprises a bladeless obturator (18) having a rectangular tip

(27j) with a conical surface (75j) between two cylindrical surfaces (95j, 99j). At least one ridge (93j) extends radially outwards from the conical surface and from the distal one of the two cylindrical surfaces.

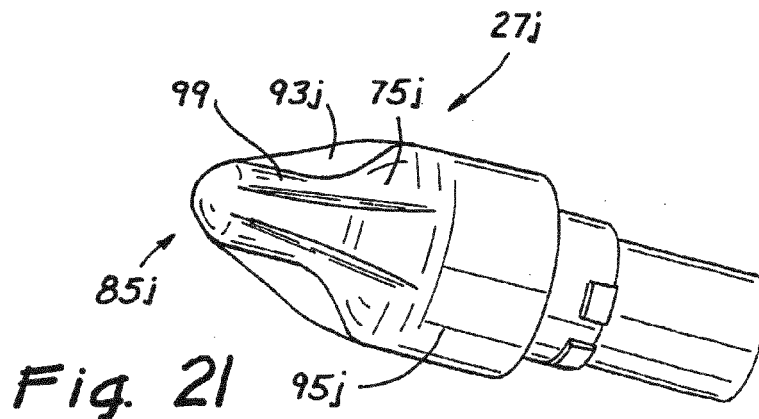

EP 2 769 683 A2

Description

[0001] This is a divisional application of European Patent Application No 11191187.1 which is a divisional application of European Application No 02706494.8.

Field of the Invention

[0002] This invention relates generally to trocar systems including obturators, and more specifically, bladeless obturators.

Background

[0003] Trocar systems have been of particular advantage in facilitating less invasive surgery across a body wall and within a body cavity. This is particularly true in the case of the abdominal surgery where trocars have provided working channels across the abdominal wall to facilitate the use of instruments within the abdominal cavity. Particularly in this form of surgery, it is advantageous to insufflate, inflate, or pressurize the abdominal cavity in order to provide an increased working volume. In the interest of maintaining this insufflation, trocars have been provided with valves which form at least two seals: across the working channel a zero seal in the absence of an instrument, and an instrument seal in the presence of an instrument.

[0004] The trocar systems of the past typically includes a cannula, which defines the working channel, and an obturator which is used to place the cannula across the abdominal wall. The obturator is inserted into the working channel of the cannula and then pushed through the abdominal wall with a penetration force of sufficient magnitude to result in penetration of the abdominal wall. Once the cannula is in place, the obturator can be removed.

[0005] In the past, obturators have been developed with an intent to provide a reduction in the force required for penetration. Sharp blades have typically been used to enable the obturator to cut its way through the abdominal wall. While the blades have facilitated a reduced penetration force, they have been of particular concern once the abdominal wall has been penetrated. Within the abdominal cavity, there are organs which need to be protected against any puncture by an obturator.

[0006] In some cases, shields have been provided with the obturators in order to sense penetration of the abdominal wall and immediately shield the sharp blades. These shielding systems have been very complex, have required a large amount of time to deploy, and have generally been ineffective in protecting the organs against the sharp blades.

[0007] Blunt-tip obturators have been contemplated with both symmetrical and asymmetrical designs. While the blunt tip tends to inhibit damage to interior organs, it also tends to increase the penetration force associated with the obturator.

[0008] In some cases, blunt tip obturators have been

adjusted to take advantage of the known anatomy associated with the abdominal wall. This anatomy includes three layers of muscle, each layer having parallel fibers which extend in a particular direction that is different for each of the layers. Notwithstanding this knowledge of the anatomy, prior attempts to develop blunt-tip obturators have not taken full advantage of this anatomical structure.

10 Summary

[0009] In accordance with the present invention, a blunt tip obturator is disclosed with characteristics which take further advantage of the abdominal anatomy. In several embodiments, the obturator has a blunt tip with a blade configuration particularly adapted for alignment parallel to the fibers of the muscle layers. With a twisted configuration, this tip transitions through a rectangular cross section to a circular cross section as it twists radially from a distal end to a proximal end of the tip. This configuration facilitates insertion with a reduced penetration force as the user moves the tip back and forth radially while applying an axial penetration force. With the blade tip having a length to width ratio greater than one, the blade can be inserted between the fibers and then rotated to provide increased fiber separation and thereby facilitate accommodation of the larger diameter associated with the cannula.

[0010] In one aspect of the invention, a surgical obturator is adapted to penetrate a body wall. The obturator includes an elongate shaft extending along an axis between a proximal end and a distal end. A bladeless tip is disposed at the distal end of the shaft, the tip having an outer surface extending distally to a blunt point. The outer surface has a pair of side sections separated by an intermediate section. One of the side sections extends from the blunt point radially outwardly with progressive position proximally along the axis. This side section includes a distal portion in proximity to the blunt point and a proximal portion in proximity to the shaft. The distal portion of the one side section is twisted radially with respect to the proximal portion of the one side section. The intermediate section extends across the blunt point of the bladeless tip.

[0011] In another aspect of the invention, a bladeless tip is disposed at the distal end of the shaft and has an outer surface with the distal portion and a proximal portion. The outer surface of the tip in radial cross section has the general configuration of a geometric shape with a side. The side of the geometric shape in the distal portion of the tip rotates in the first direction about the axis in progressive proximal radial cross sections along the axis. The side of the geometric shape in the proximal portion of the tip rotates in a second direction opposite to the first direction with progressive proximal radial cross sections along the axis.

[0012] In an additional aspect of the invention, the bladeless tip has an outer surface including a pair of gen-

erally opposed sections. The outer surface has a geometric shape in progressive radial cross sections from a distal cross section to a proximal cross section. A pair of generally opposed sections of the outer surface appear as a pair of lines in each of the progressive radial cross sections, with at least one of the lines becoming increasingly arcuate in the progressive radial cross sections.

[0013] In a further aspect of the invention, the bladeless tip is coupled to the shaft and has an axis extending between a proximal end and a distal end, the tip having an outer surface with a generally conical configuration and a blunt tip. Portions of the outer surface define at least one recess extending relative to the axis generally between the proximal end and the distal end of the tip.

[0014] These and other features and advantageous of the invention will become more apparent with a discussion of preferred embodiments and reference to the associated drawings.

Description of the Drawings

[0015]

Figure 1 is a side elevation view of a trocar system including a cannula with associated valve housing, and an obturator with a blunt tip extending through the working channel of the cannula to facilitate placement across the abdominal wall;

Figure 2 is a perspective view of a preferred embodiment of the blunt tip illustrated in Figure 1;

Figure 3 is a side elevation view of the blunt tip taken along lines 3-3 of Figure 2;

Figure 4 is a side elevation view taken along lines 4-4 of Figure 3;

Figure 5 is an end view taken along lines 5-5 of Figure 4;

Figure 6 is a radial cross-section view taken along line 6-6 of Figure 4;

Figure 7 is a radial cross-section view taken along line 7-7 of Figure 4;

Figure 8 is a radial cross section view taken along lines 8-8- of Figure 4;

Figure 9 is a radial cross section view taken along lines 9-9 of Figure 4;

Figure 10 is a radial cross section view taken along lines 10-10 of Figure 4;

Figure 11 is a schematic view illustrating each of the Figures of 5-10 super-imposed to facilitate an understanding of the twisted configuration of the blunt tip; and

Figures 12-37 show perspective views of other embodiments of the blunt tip of the present invention.

Description of Preferred Embodiments

[0016] A trocar system is illustrated in Figure 1 and designated by the reference numeral 10. This system includes a cannula 12, defining a working channel 14,

and a valve housing 16. The system 10 also includes an obturator 18 having a shaft 21 extending along an axis 23. A handle 25 is disposed at a proximal end of the shaft at 21 while a blunt tip 27 is disposed at a distal end of the shaft 21. The shaft 21 of the obturator 18 is sized and configured for disposition within the working channel 14 of the cannula 12. With this disposition, illustrated in Figure 1, the obturator functions to penetrate a body wall such as the abdominal wall 30 to provide the cannula with access across the wall 30 and into a body cavity, such as the peritoneal or abdominal cavity 32. The blunt tip 27, which initially facilitates penetration of the abdominal wall 30 can be removed with the obturator 18 once the cannula 12 is operatively disposed with the working channel 14 extending into the abdominal cavity 32.

[0017] In order to facilitate penetration of the abdominal wall 30 by the trocar system 10, a penetration force, represented by an arrow 34, is typically applied along the axis 23. It can be appreciated that the force required to move the system through the abdominal wall 30 drops significantly once the wall 30 is penetrated. Further application of the force 34, even for an instant of time, can result in injury to organs within the cavity 32. Where the obturators of the past have included blades facilitating penetration of the abdominal wall, these blades have been particularly threatening and detrimental to the interior organs following penetration.

[0018] Consequently, in accordance with the present invention, the tip 27 of the obturator 18 is provided with a blunt configuration. As noted, blunt tips have been used in the past to significantly reduce any potential for damage to interior organs. Unfortunately, these blunt tips have increased significantly the amount of force 34 required for penetration of the abdominal wall 30.

[0019] The blunt tip 27 of the present invention takes into account an anatomical configuration of the abdominal wall 30 with an improved structural design and method of insertion.

[0020] In order to fully appreciate the aspects of this invention, it is helpful to initially discuss the anatomy associated with the abdominal wall 30. This wall 30 typically includes the skin or fascia 35 and a series of muscles in the form of muscle layers 36, 38 and 41. These layers are each defined by muscle fibers which extend generally parallel to each other in a direction which is different for each of the layers. For example, the layer 38 is composed of fibers 43 which extend generally parallel in a particular direction. Fibers 45 associated with the layer 36 extend generally parallel at an angle such as 45 degrees to the particular direction of the fibers 43. Fibers 47 associated with the layer 41 also extend in a parallel direction but at an angle of about 45 degrees to the fibers 43 and an angle of about 90 degrees to the fibers 45.

[0021] Having noted the directional nature of the fibers, such as the fibers 45, it can be appreciated that such a structure is most easily penetrated by a tip 27 having a narrow width which is capable of being moved generally parallel to and between the fibers associated with a par-

ticular muscle layer. This narrow width might be provided with a point configuration or in the case of a preferred embodiment, a line or rectangular configuration having the narrow width and a longer length. With the length oriented parallel to the fibers of a particular layer a reduced penetration force 34 is required to push the obturator 18 through the particular layer.

[0022] Unfortunately, with the fibers 45, 43 and 47 oriented at 45 degrees to each other, proper alignment of the tip 27 for penetration of one layer, such as the layer 36, will not necessarily result in proper alignment for penetration of the next layer, such as the layer 38. For this reason, the rectangular configuration for the tip 27 is twisted slightly so that penetration of the first layer 36 begins to rotate the distal end of the tip 27 into proper orientation for penetration of the next layer 38.

[0023] The twisted configuration of the tip 27 also causes the tip 27 to function with the mechanical advantage of a screw thread. With this configuration, a preferred method of placement requires that the user grip the handle 25 of the obturator 18, and twist it about the axis 27. This twisting motion in combination with the screw configuration of the tip 27 converts radial movement into forward movement along the axis 23. Thus, the user applies both a forwardly directed force as well as a radial force to move the trocar system 10 in a forward direction. Since all of the force supplied by the user is not directed axially along the arrow 34, this concept avoids the tendency of prior trocar systems to jump forward upon penetration of the wall 30.

[0024] The twisted and rectangular configuration of the tip 27 is most apparent in the schematic view of Figure 2 and the side views of Figures 3 and 4. In this embodiment, the tip is composed generally of four surfaces: two opposing major surfaces 50 and 52, separated by two side surfaces 54 and 56 which extend between an end surface 58 and a proximal base 61. A plane drawn through the axis 23 would show the tip 27 in this case, to be composed of two symmetrical halves.

[0025] The major surfaces 50 and 52 and the side surfaces 54 and 56 generally define the cross section of the tip 27 to be rectangular from the end surface 58 to the proximal base 61. This configuration can best be appreciated with reference to the cross section views of Figures 5-10. In Figure 5, the distal end of the tip 27 is shown as a rectangle having its greatest length-to-width ratio. This rectangle, designated by the reference numeral 63, also has a twisted, S-shaped configuration at the distal-most end of the tip 27.

[0026] As views are taken along progressive proximal cross sections, it can be seen that the rectangle 63 becomes less twisted, and the width increases relative to the length of the rectangle 63. The spiral nature of the tip 27 is also apparent as the rectangle moves counterclockwise around the axis 23 in the embodiment of Figure 2. This is perhaps best appreciated in a comparison of the rectangle 63 in Figure 7 relative to that in Figure 6. With progressive proximal positions, the rectangle 63 be-

gins to fatten with a reduction in the ratio of length to width. The long sides of the rectangle 63 also tend to become more arcuate as they approach a circular configuration most apparent in Figures 9 and 10. In these figures, it will also be apparent that the rotation of the rectangle 63 reaches a most counterclockwise position and then begins to move clockwise. This is best illustrated in Figures 8, 9 and 10. This rotation back and forth results from the configuration of the side surfaces 54 and 56, which in general, have a U-shape best illustrated in Figures 2 and 3.

[0027] The ratio of the length-to-width of the rectangle 63 is dependent on the configuration of the side surfaces 54 and 56, which defined the short sides of the rectangle 63, as well as the configuration of the major surfaces 50 and 52 which define the long sides of the rectangle 63. Again with reference to Figure 3, it can be seen that the side surfaces 50 and 52 are most narrow at the distal end of the tip 27. As these surfaces extend proximally, they reach a maximum width near the point of the most counterclockwise rotation, shown generally in Figure 8, and then reduce in width as they approach the proximal base 61. Along this same distal to proximal path, the major surfaces 50 and 52 transition from a generally flat configuration at the distal end to a generally conical configuration at the proximal end 61.

[0028] In the progressive views of Figures 6-10, the rectangle 63 is further designated with a lower case letter a, b, c, d, or e, respectively. In Figure 11, the rectangles 63 and 63a-63c are superimposed on the axis 23 to show their relative sizes, shapes, and angular orientations.

[0029] A preferred method of operating the trocar system 10 benefits significantly from this preferred shape of the blunt tip 27. With a rectangular configuration at the distal surface 58, the end of the tip 27 appears much like a flathead screwdriver. The length of the surface 58 is aligned parallel with the fibers 45 of the layer 36. With this shape, the simple back and forth twisting motion tends to separate the fibers 45 along natural lines of separation, opening the muscle layer 36 to accept the larger diameter of the cannula 12. By the time the first layer 36 is substantially penetrated, the twisted configuration of the blunt tip 27 turns the rectangle at the distal surface 58 more into a parallel alignment with fibers 43 in the next layer 48. Again, a twisting or dithering motion facilitates an easy separation of these fibers requiring a significantly reduced penetration force along the arrow 34.

[0030] When the muscle layer 38 is sufficiently penetrated, the twisted configuration of the tip 27 automatically rotates the rectangular end surface 58 into generally parallel alignment with the fibers 47 of the next layer 41. Again, the natural separation of these fibers 47 together with the unique configuration of the tip 27, accommodates the further penetration of the layer 41 until the cannula 12 is operatively disposed across the wall 30. It will be noted in particular that the fibers 45, 43, and 47 are naturally separated, not cut. This has two advantageous effects: 1) the abdominal wall 30 easily closes upon re-

removal of the trocar system 10; and 2) without cutting, very little bleeding is encountered and very little healing is required to seal the wound permanently.

[0031] Certainly, one of the primary purposes of the invention is to maintain control and facilitate entry into the body cavity 32 while inhibiting any tearing or cutting of tissue. The tip 27 is bladeless, blunt, and atraumatic to organs and bowel within the peritoneal or abdominal cavity 32. The tip 27 also minimizes tenting of the peritoneum and allows for a safe entry. The device is used in conjunction with the cannula 12 to create an initial entry way into the peritoneal cavity 32. The obturator is first inserted through the valve housing 16 and into the cannula 12. The entire trocar system 10 is then inserted through the abdominal wall 30 and into the peritoneal cavity 32. Once the cannula 12 is properly placed, the obturator 18 can be removed.

[0032] This facilitates a unique method of separating tissue and could apply to any object with a slim profile and flat sides. When inserted into the peritoneum the slim profile of the device requires very little area to move safely between tissue and muscle fibers. The device can then be rotated in alternating clockwise and counterclockwise directions while the downward penetration force is applied. When rotated in alternating directions, the tissue is moved apart and a larger opening is created for a profile of greater cross sectional area to follow. This process continues with safety and ease until the device enters the peritoneal cavity 32 and moves to its operative position.

[0033] When the cannula 12 is ultimately removed, the size of the opening left in the tissue is minimal. Importantly, this opening is left sealed due to a dilating effect caused by the mere separation of fibers. Note that there are no blades or sharp edges to cut muscle fiber, and thereby prolong the healing process.

[0034] In other embodiments, the tip 27 of the obturator can be fabricated of a translucent or clear material, and the handle provided with a passageway along the inside of the tip. With this configuration, a laparoscope can be inserted through the handle of the obturator and through the shaft to the tip. Insertion can then be monitored through the laparoscope, and the clear tip of the obturator, in order to further ensure safe entry.

[0035] The obturator 18 can be constructed as a single component or divided into two components such as the shaft 21 and the tip 27. If the obturator 18 is constructed as a single component, it may be constructed of either disposable or reusable materials. If the obturator 18 is constructed as two or more components, each component can be made either disposable or useable as desired for a particular configuration. In certain preferred embodiments, the obturator shaft 21 and handle are made of a reusable material, such as a metal or an autoclavable polymer in order to facilitate re-sterilization and reuse of these components. In this embodiment, the tip 27 is made of a material that is not autoclavable and therefore is adapted to be disposable.

[0036] The blunt tip 27 can be coated or otherwise constructed from a soft elastomeric material. In such a case, the material could be a solid elastomer or composite elastomer/polymer.

5 **[0037]** The obturator could also contain a spring-biased shield to cover the tip. On entry the shield could be retracted exposing the tip and then immediately and automatically moved distally back over the tip upon full entry into the peritoneal cavity 32. The action of the shield could also serve as an indicator to the surgeon that safe entry had been achieved. The obturator could be constructed in a manner wherein the tip 27 itself is spring biased and keyed to the shaft. The tip 27 would retract during insertion but would then deploy upon entry into the peritoneal cavity 32. This deployment action could also further serve as an indicator of safe entry.

10 **[0038]** The shaft 21 of the obturator 18 could be partially or fully flexible. With this configuration, the obturator 18 could be inserted through a passageway containing one or more curves of virtually any shape. A partially or fully flexed obturator 18 could then be used with a flexible cannula 12 allowing greater access to an associated body cavity 32.

15 **[0039]** The obturator 18 could also be used as an insufflation needle and provided with a passageway and valve to administer carbon dioxide or other insufflation gas to the peritoneal cavity 32. The obturator 18 could also be used with an insufflation needle cannula, in which cases removal of the obturator 18 upon entry would allow for rapid insufflation of the peritoneal cavity 32.

20 **[0040]** The obturator 18 could also be constructed to permit free spinning of the tip about the axis 23. This would allow the tip 27 to find its own way through the abdominal wall 30 rather than relying on the user for clockwise and counterclockwise rotation.

25 **[0041]** Other embodiments of the invention are illustrated in Figure 12-37 where elements of structure similar to those previously disclosed are designated with the same reference numeral followed by the lower case letters "a" to "z", respectively. Thus, in Figure 12, the tip 27 is referred to with the reference numeral 27a while in Figure 37, the tip is referred to with a reference numeral 27z.

30 **[0042]** In Figure 12, the obturator tip 27a is formed with a conical surface 75 having an axis 77. In this embodiment, the axis 77 of the surface 75 is collinear with the axis 23a of the tip 27a. A plurality of recesses 79 are formed in the conical surface 75 around the axis 77. These recesses are formed with side walls 81 which extend radially inwardly to a valley 83. In this embodiment, the conical surface 75 has an angle with respect to the axis 77 which is greater than an angle between the valley 83 and the axis 77. As a result, the recesses 79 appear to deepen relative to the surface 75 from a distal end 85 to a proximal end 87 of the tip 27a. The sidewalls 81 have a generally constant angle with respect to the conical surface 75 and consequently have an increased area toward the proximal end 87. The valley 83 has a generally

constant width as it extends towards the proximal end 87.

[0043] In this embodiment, the tip 27a also has a cylindrical mounting shaft 89 with mounting lugs 91. This mounting shaft 89 is adapted to closely fit within the obturator shaft 21 (Figure 1). The mounting lugs 91 can engage holes or shoulders within the shaft 21 to facilitate a fixed but removable relationship between the shaft 21 and tip 27a.

[0044] In Figure 13, the tip 27b is also characterized by the conical surface 75b, the cylindrical mounting shaft 89 and the lugs 91b. In this case, the tip 27b is provided with ridges 93 which extend radially outwardly from the conical surface 75b. The ridges 93 can have a constant width or a width which increases proximally as in the illustrated embodiment. The height of the ridges above the conical surface 75b can be either constant or variable between the distal end 85b and the proximal end 87b.

[0045] The obturator tip 27c in Figure 14 is similar to that of Figure 13 except that the ridges 93c are not straight but rather curved as they extend between the distal end 85c and the proximal end 87c. In this case, the ridges have an angle with respect to the axis 77c which increases proximally both radially and axially.

[0046] The obturator tip 27d in Figure 15 is similar to that of Figure 12 except that the axis 77d of the conical surface 75d is curved rather than straight. Accordingly, the axis 77d of the conical surface 75d is curved relative to the axis 23d of the obturator shaft 21d.

[0047] The obturator tip 27e in Figure 16 is similar to that of Figure 12 in that it includes the recesses 79e which extend from the distal end 85e to the proximal end 87e. In this case however, the tip 27e has a cylindrical surface 95 which extends proximally of the conical surface 75e between the distal tip 85e and the mounting shaft 89e. The recesses 79e in this embodiment extend along both the conical surface 75e and the cylindrical surface 95.

[0048] The obturator tip 27f of Figure 17 is similar to that of Figure 16 except that the recesses 79f extend through the distal end 85f. In the illustrated embodiment, four of the recesses 79f provide the distal end 85f with the shape of the letter "X."

[0049] The obturator tip 27g in Figure 18 is similar to that of Figure 12 except that the surface 75g is more rounded thereby providing the tip 27g with a parabolic or bullet shape. Also, the recesses 79g are disposed at an angle with respect to any plane passing through the axis 77g.

[0050] The obturator tip 27h in Figure 19 has the cylindrical surface 95h at its proximal end 87h and a series of grooves 97 which extend circumferentially of the axis 77h with diameters which increase from the distal end 85h to the cylindrical surface 95h. Each of the recesses or ridges in the series 97h is disposed in an associated plane that is perpendicular to the axis 77h.

[0051] In the embodiment of Figure 20, the tip 27i includes recesses 79i which are similar to those illustrated in Figure 17 in that they extend through the distal end 85i. This embodiment also includes the ridges 93i which

are disposed between the recesses 79i and extend toward the cylindrical surface 95i at the proximal end 87i. The recesses 79i in Figure 20 have individual widths which decrease proximally.

[0052] In the embodiment of Figure 21, the tip 27j includes the conical surface 75j which transitions proximally into the cylindrical surface 95j. Distally of the conical surface 75j a second cylindrical surface 99j is provided which extends to the distal end 85j. Ridges 93j extend radially outwardly from the second surface 99 and the conical surface 75j.

[0053] The obturator tip 27k in Figure 22 is similar to previous embodiments having the conical surface 75k and the cylindrical surface 95k. In this embodiment, the ridges 93k include distally portions 101 and proximal portions 103 which extend in planes passing through the axis 77k. Between the proximal portions 103 and distal portions 101, the ridges 93k include intermediate portions 105 which extend in planes that do not include the axis 77k.

[0054] In Figure 23, the tip 27L is similar to that of Figure 17 except that the second cylindrical surface 99L is provided in this embodiment. The recesses 79L have a generally constant width along the second cylindrical surface 99L and the conical surface 75L. These recesses 79L do not extend into the cylindrical surface 95L.

[0055] The obturator tip 27m in Figure 24 is similar to that of Figure 21 except that it does not include the second cylindrical surface 99m. In this case, the conical surface 75m extends to the distal end 85m with a slightly concave shape. The ridges 93m transition into the surface 75m at the distal end 85m and transition into the cylindrical surface 95m at the proximal end 87m. Between these two ends, the ridges 93m have a height which is increased by the concave configuration of the surface 75m.

[0056] The tip 27n in Figure 25 is similar to the tip 27g in Figure 18 in that the outer surface 75n has a generally bullet-shaped configuration. The recesses 79n include a recess 101 which curves proximally in a counterclockwise direction, and a recess 103 which curves proximally in a clockwise direction.

[0057] The tip 27o in Figure 26 is similar to that of Figure 25 but includes a further recess 106 which spirals toward the distal end 85o in a clockwise direction. This spiral recess 105 crosses the recess 101o in this embodiment.

[0058] In Figure 27, the tip 27p includes the conical surface 75p which extends toward the distal end 85p at its apex. The apex of the outer conical surface 75e is blunted at the distal end 85p. This embodiment also includes the mounting stub 89p and associated lugs 91p.

[0059] The tip 27q in Figure 28 has the outer surface 75q with a bullet-shaped configuration. The recesses 79q in this embodiment include three recesses, 107, 110, and 112 which spiral in a generally parallel relationship proximally in a counterclockwise direction.

[0060] The tip 27r in Figure 29 has an outer surface 75r with a bullet-shaped configuration, and a plurality of

recesses 79r which extend generally axially from the distal end 85 as to the proximal end 87r. The recesses 79r are generally symmetrical and include a proximal portion 113, and a distal portion 114 with sidewalls 116 and 118 which define a deep valley 121 that extends generally parallel to the axis 27r. The proximal portion 113 of the recess 112 comprises a plane 123 which extends between the sidewalls 118 and 121 from the valley 116 radially outwardly with progressive positions toward the proximal end 87r.

[0061] The tip 27s in Figure 30 is similar to that of Figure 29, but includes fewer recesses 79s. Also, the tip 27s has a nose that is more pointed thereby providing the outer surface 75s with a concave configuration near the distal end 85s.

[0062] Figure 31 shows a perspective view of the tip 27t with a bullet-shaped outer surface 75t and a plurality of the recesses 79t. In this case the recesses are straight but nevertheless have an angular relationship with the axis 77t. These recesses 79t extend through the distal end 85t but stop short of the proximal end 87t.

[0063] The tip 27u in Figure 32 is similar to that of Figure 15 in that the axis 77u is curved relative to the axis 23u which is straight. Also, in this embodiment, there are no ridges or recesses.

[0064] In Figure 33, the tip 27v has an outer surface 75v which is formed by individual frustoconical portions 125, 127, 130, and 132, which have progressively smaller average diameters. These conical portions 125-132 appear to be stacked with their individual axes disposed along the common axis 77v.

[0065] The tip 27w in Figure 34 is similar to that of Figure 20 in that it includes both the recesses 79w, as well as the ridges 93w. In this embodiment, which includes both a distal portion 134, as well as a proximal portion 136. These portions 124 and 136 have a generally common dimension along the axis 77w.

[0066] The tip 27x in Figure 35 includes the conical surface 75x as well as the cylindrical surface 95x. The recesses 79x are oriented generally in respective radial planes. These recesses 79x are similar in shape and have a width which increases toward the distal end 87x.

[0067] The tip 27y in Figure 36 is similar to that of Figure 19. It includes concentric circular structures at the distal end 85y. In this case however, the structures are a series of recesses 97y rather than ridges. This embodiment includes at least one ridge 93y, however, which extends radially outwardly with progressive proximal positions along the axis 77y.

[0068] The tip 27z in Figure 37 is similar to that of Figure 35 except that it includes recesses 79z which are fewer in number but wider in size. Also, the nose of the tip 27 at the distal end 85z is accentuated in the embodiment of Figure 37.

[0069] It will be understood that many modifications can be made to the various disclosed embodiments without departing from the spirit and scope of the concept. For example, various sizes of the surgical device are con-

templated as well as various types of constructions and materials. It will also be apparent that many modifications can be made to the configuration of parts as well as their interaction. For these reasons, the above description should not be construed as limiting the invention, but should be interpreted as merely exemplary of preferred embodiments. Those skilled in the art will envision other modifications within the scope and spirit of the present invention as defined by the following claims.

[0070] Other non-limiting features and aspects of the invention are set out in the following clauses:

A. A surgical obturator adapted to penetrate a body wall, comprising:

an elongate shaft extending along an axis between a proximal end and a distal end;
 a bladeless tip disposed at the distal end of the shaft the tip having an outer surface extending distally to a blunt point;
 the outer surface having a pair of side sections separated by an intermediate section;
 the side sections extending from the blunt point radially outwardly with progressive positions proximally along the axis;
 the side sections including a distal portion in proximity to the blunt point, and a proximal portion in proximity to the shaft; and
 the distal portion of the side sections being twisted radially with respect to the proximal portion of the side section.

B. The surgical obturator recited in Clause A, wherein the intermediate section extends across the blunt point of the bladeless tip.

C. The surgical obturator recited in Clause B, wherein:

the intermediate section includes a distal portion in proximity to the blunt point and a proximal portion in proximity to the shaft;

the distal portion of the intermediate surface being twisted in a first radial direction; and the proximal portion of the intermediate surface being twisted in a second radial direction opposite the first radial direction.

D. The surgical obturator recited in Clause C, wherein the distal portion of the intermediate section has a width which increases proximally.

E. The surgical obturator recited in Clause D, wherein the proximal portion of the intermediate section has a width which decreases proximally.

F. The surgical obturator recited in Clause A, wherein the outer surface in radial cross section has the general configuration of a geometric shape.

G. The surgical obturator recited in Clause A, wherein the intermediate section of the outer surface separates the pair of side sections of the outer surface and extends distally to the blunt point, across the blunt point, and proximally from the blunt point.

H. A surgical obturator adapted to penetrate a body wall, comprising:

- an elongate shaft extending along an axis between a proximal end and a distal end;
- a bladeless tip disposed at the distal end of the shaft, the tip having an outer surface with a distal portion and a proximal portion;
- the outer surface of the tip in radial cross section having the general configuration of a geometric shape with a side;
- the side of the geometric shape in the portion of the tip rotating in a first direction about the axis in progressive proximal radial cross sections along the axis.

I. The surgical obturator recited in Clause H, further comprising:

the side of the geometric shape in the proximal portion of the tip rotating in a second direction opposite to the first direction with progressive radial cross sections along the axis.

J. The surgical obturator recited in Clause H, wherein the geometric shape is a rectangle.

K. The surgical obturator recited in Clause J, wherein the side is a long side of the rectangle and the rectangle further comprises:

- a generally short side having a length less than that of the long side; and
- the ratio of the length of the long side to the length of the short side decreases with progressive proximal radial cross sections along the axis.

L. The surgical obturator recited in Clause J, wherein the rectangle at the point of the tip has the general shape of the letter "S."

M. A surgical obturator adapted to penetrate a body wall, comprising:

- an elongate shaft extending along an axis between a proximal end and a distal end;
- a bladeless tip having an outer surface including a pair of generally opposed sections;
- the outer surface having a generally geometric

shape in progressive radial cross sections from a distal cross section to a proximal cross section; the pair of generally opposed sections of the outer surface appearing as a pair of lines in each of the progressive radial cross sections; and at least one of the pair of lines becoming increasing arcuate in the progressive radial cross sections.

N. The surgical obturator recited in Clause M, wherein the area of the geometric shape increases along the progressive radial cross sections.

O. The surgical obturator recited in Clause N, wherein:

- the geometric shape is a rectangle having a first side with a first length, and a second side with a second length shorter than the first length;
- the rectangle having a particular ratio characterized by the first length divided by the second length; and
- the particular ratio decreasing along the progressive radial cross sections.

P. The surgical obturator recited in Clause N, wherein the at least one of the pair of lines rotates in a first direction around the axis in the progressive radial cross sections.

Q. The surgical obturator recited in Clause P, wherein the at least one line rotates around the axis in a second direction opposite to the first direction in the progressive radial cross sections.

R. A surgical obturator adapted to penetrate a body wall, comprising:

- an elongate shaft extending along an axis;
- a bladeless tip coupled to the shaft and having an axis extending between a proximal end and a distal end, the tip having an outer surface with a generally conical configuration and a blunt tip;
- portions of the outer surface of the tip defining at least one recess extending relative to the axis generally between the proximal end and the distal end of the tip;

S. The surgical obturator recited in Clause R, wherein the recess extends generally in a plane common to the axis of the tip.

T. The surgical obturator recited in Clause R, wherein the recess extends generally spirally of the axis of the tip.

U. The surgical obturator recited in Clause R, wherein the recess extends to the blunt point of the bladeless tip.

V. The surgical obturator recited in Clause U, wherein the blunt point of the bladeless tip has the shape of a cross.

W. The surgical obturator recited in Clause T, wherein:

the recess is a first recess spiraling relative to the axis in a first direction to the access; the portions define a second recess spiraling relative to the axis in a second direction opposite of the first direction.

X. The surgical obturator recited in Clause R, wherein the axis is curved.

Claims

1. A surgical obturator (18) adapted to penetrate a body wall, comprising:

an elongate shaft (21) extending along an axis (23) between a proximal end and a distal end; and
 a bladeless tip (27) at the distal end of the shaft (21), the tip (27) includes a conical surface (75j), a first cylindrical surface (95j) and a second cylindrical surface (99j); the conical surface (75j) is located between the first cylindrical surface (95j) and the second cylindrical surface (99j); the second cylindrical surface (99j) being located distally of the conical surface (75j), and the conical surface (75j) transitions distally into the second cylindrical surface (99j); the second cylindrical surface (99j) extends to the distal end of the tip (27), the first cylindrical surface (95j) is located proximally of the conical surface (75j); and the conical surface (75j) transitions proximally into the first cylindrical surface (95j); and the tip (27) further includes at least one ridge (93j) extending radially outwardly from the second cylindrical surface (99j) and the conical surface (75j).

2. The surgical obturator of Claim 1 wherein the at least one ridge (93j) extends along the tip (27) such that a major component of the ridge (93j) is parallel to the axis (27).

3. The surgical obturator of any of the preceding claims wherein the distal end is rounded.

4. The surgical obturator of any of the preceding claims wherein the obturator (18) comprises a lumen open at a proximal end of obturator (18).

5. The surgical obturator of Claim 4 wherein the obtu-

rator (18) is translucent and the lumen is configured to receive a laparoscope therein.

6. The surgical obturator of Claim 1 further including a cannula (12) having a working channel (14) extending between an on open proximal end and an open distal end; the cannula (12) is configured to receive the elongate shaft (21) inside the working channel (14) of the cannula (12).

7. The surgical obturator of Claim 1 wherein the tip (27) is adapted to closely fit with the elongate shaft to facilitate a fixed or removable relationship between the elongate shaft (21) and the tip (27).

8. The surgical obturator of Claim 1 wherein the ridges (93k) include a distal portions (101), proximal portions (103), and intermediate portions (105); the intermediate portions (105) are located between the proximal portions (103) and the distal portions (101); the distal portions (101) being distal to the intermediate portions (105); the proximal portions (103) being proximal to the intermediate portions (105); the proximal portions (103) and the distal portions (101) of the ridges (93k) extend in planes passing through the axis (77k) along the conical surface (75k); and the intermediate portions (105) of the ridges (93k) extend in planes that do not include the axis (77k).

9. The surgical obturator of Claim 1 wherein the tip (27) further includes recesses (79) and wherein the ridges (93) are disposed between the recesses and extend toward the first cylindrical surface (95i).

10. The surgical obturator of Claim 9 wherein the recesses (79L) have a generally constant width along the second cylindrical surface (99L) and the conical surface (75L).

11. The surgical obturator of any of Claims 9 to 10 wherein the recesses (79L) do not extend into the first cylindrical surface (95L).

12. The surgical obturator of any of the preceding claims wherein the ridges (93) have a constant width or width that increases proximally.

13. The surgical obturator of any of the preceding claims wherein the ridges (93) lie in planes passing through the axis (23).

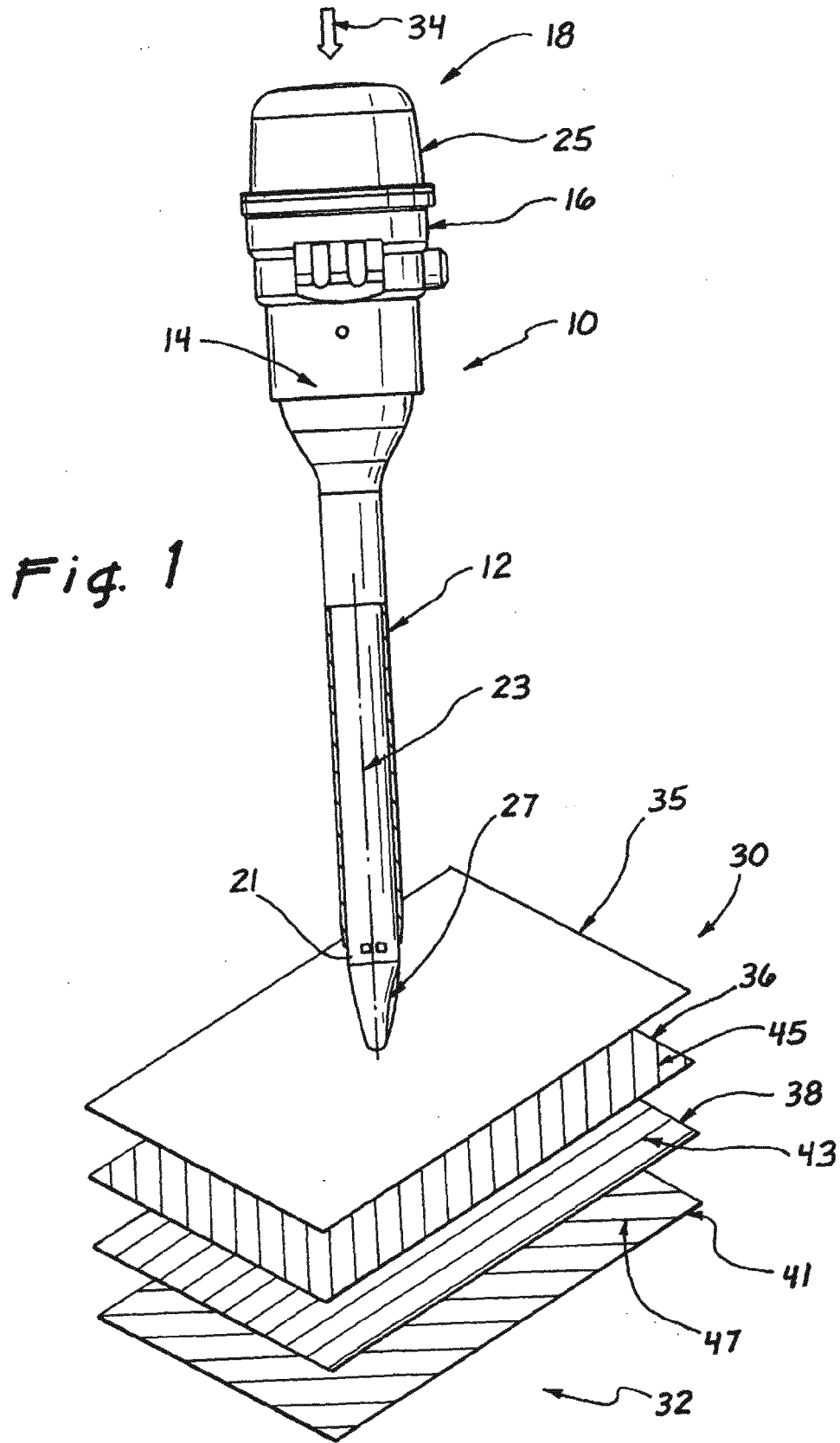

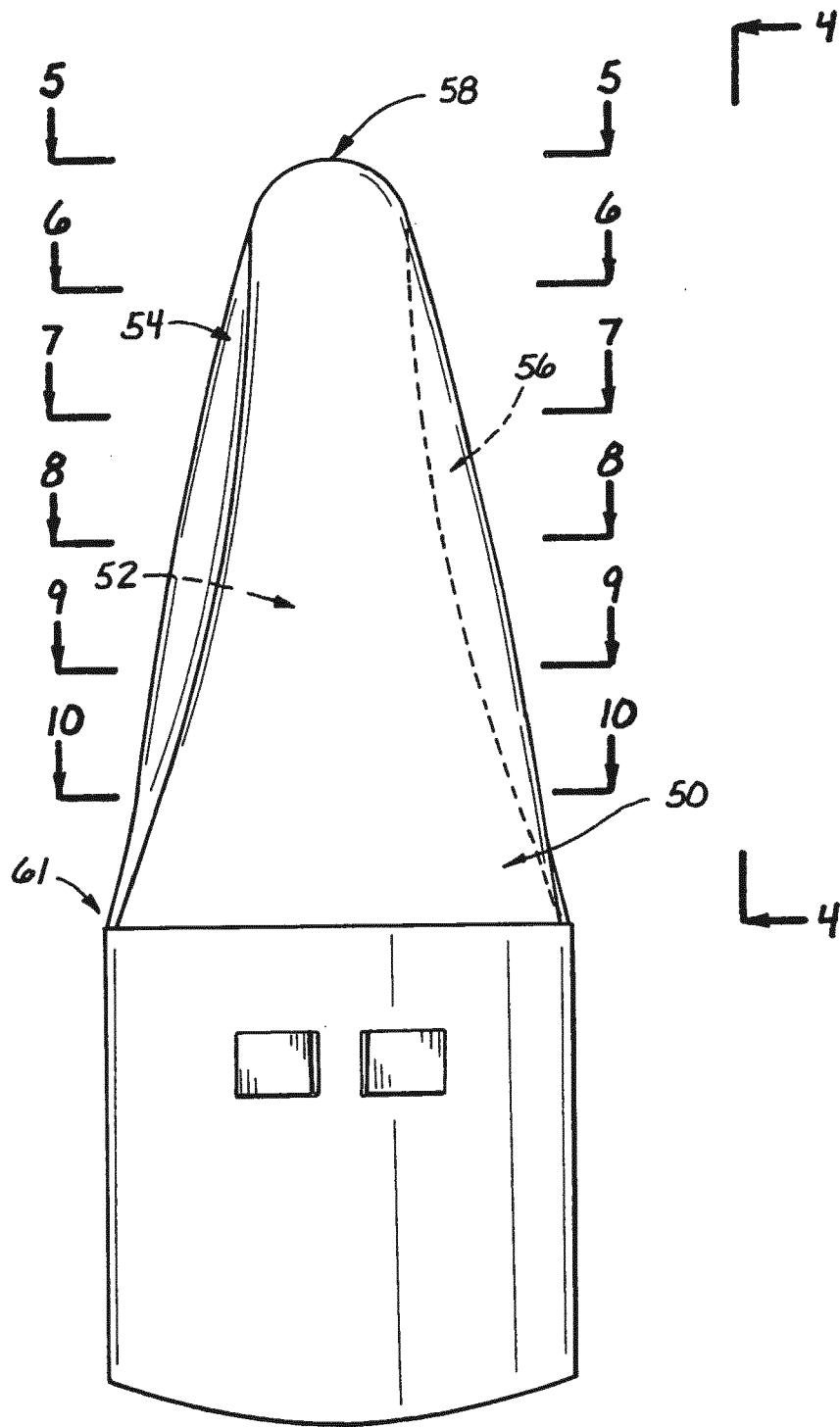
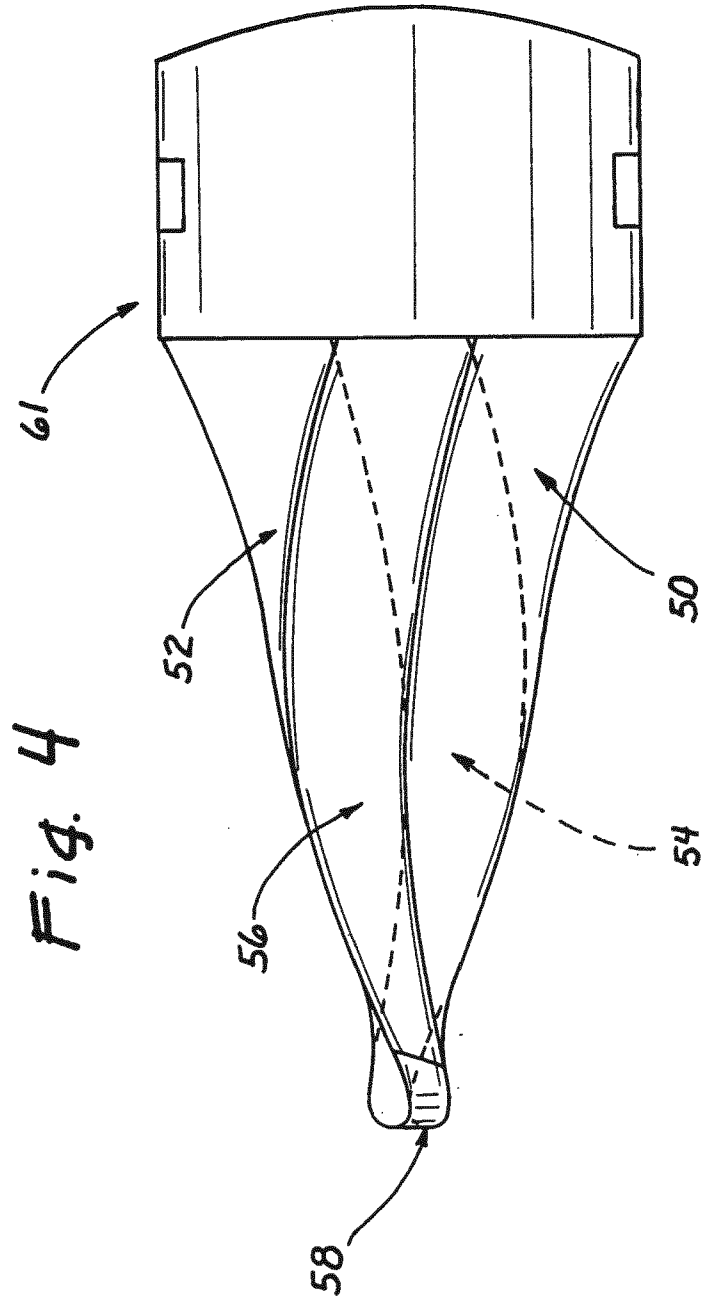

Fig. 3



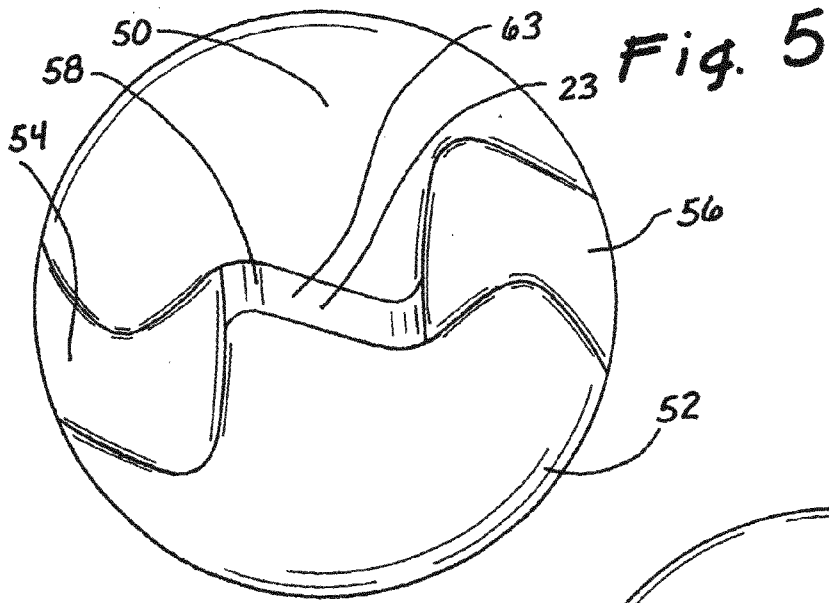

Fig. 6

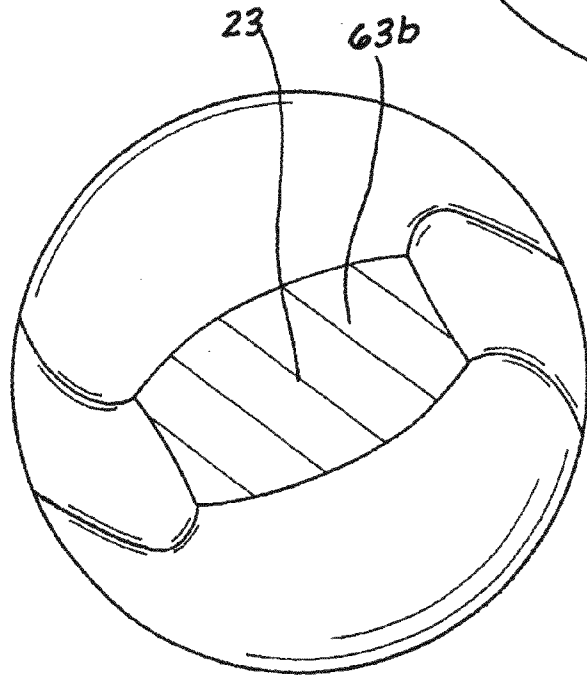
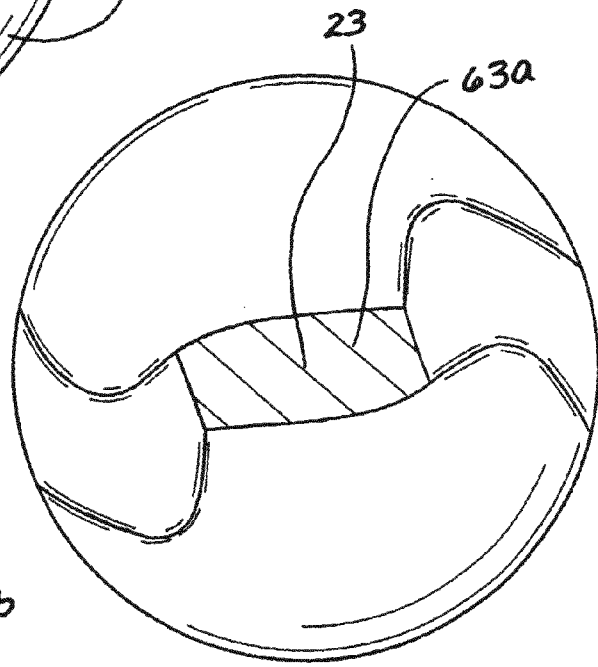

Fig. 7

Fig. 8

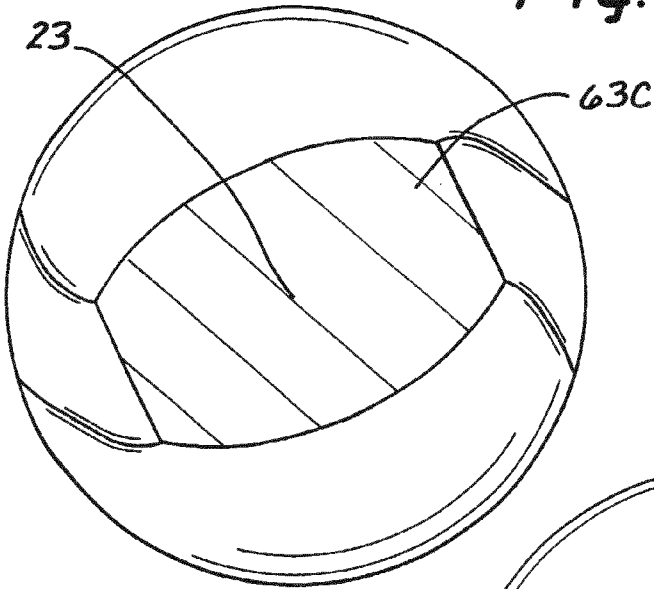

Fig. 9

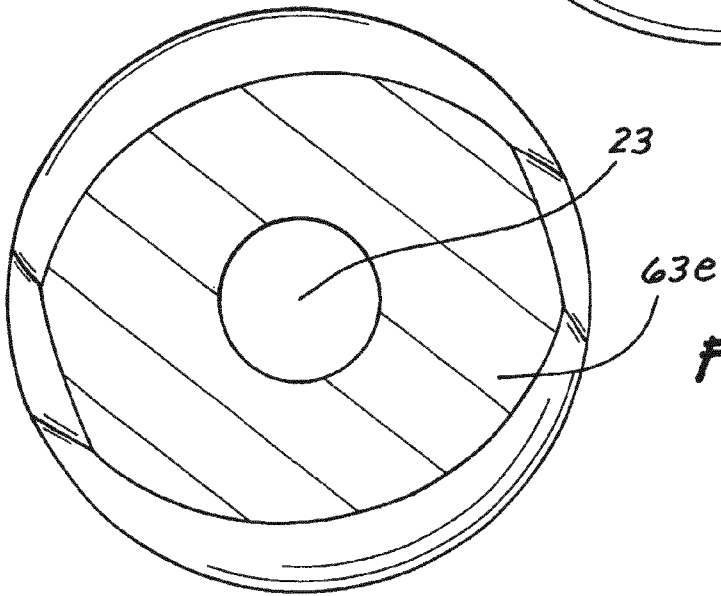
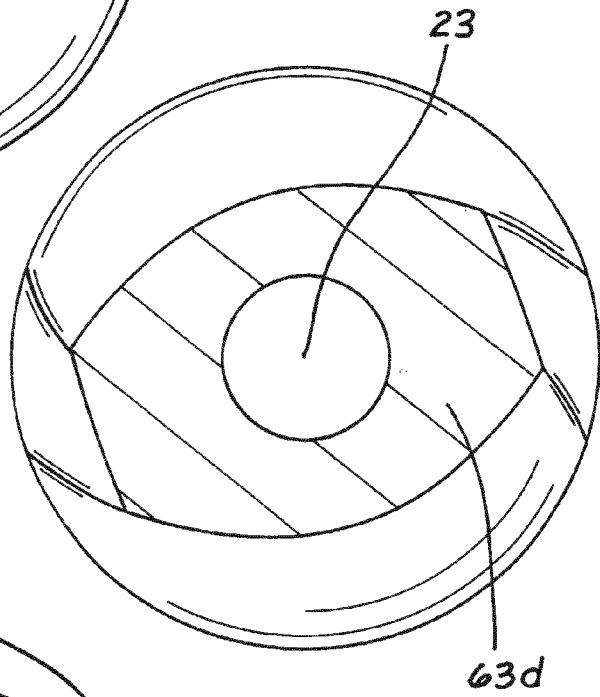

Fig. 10

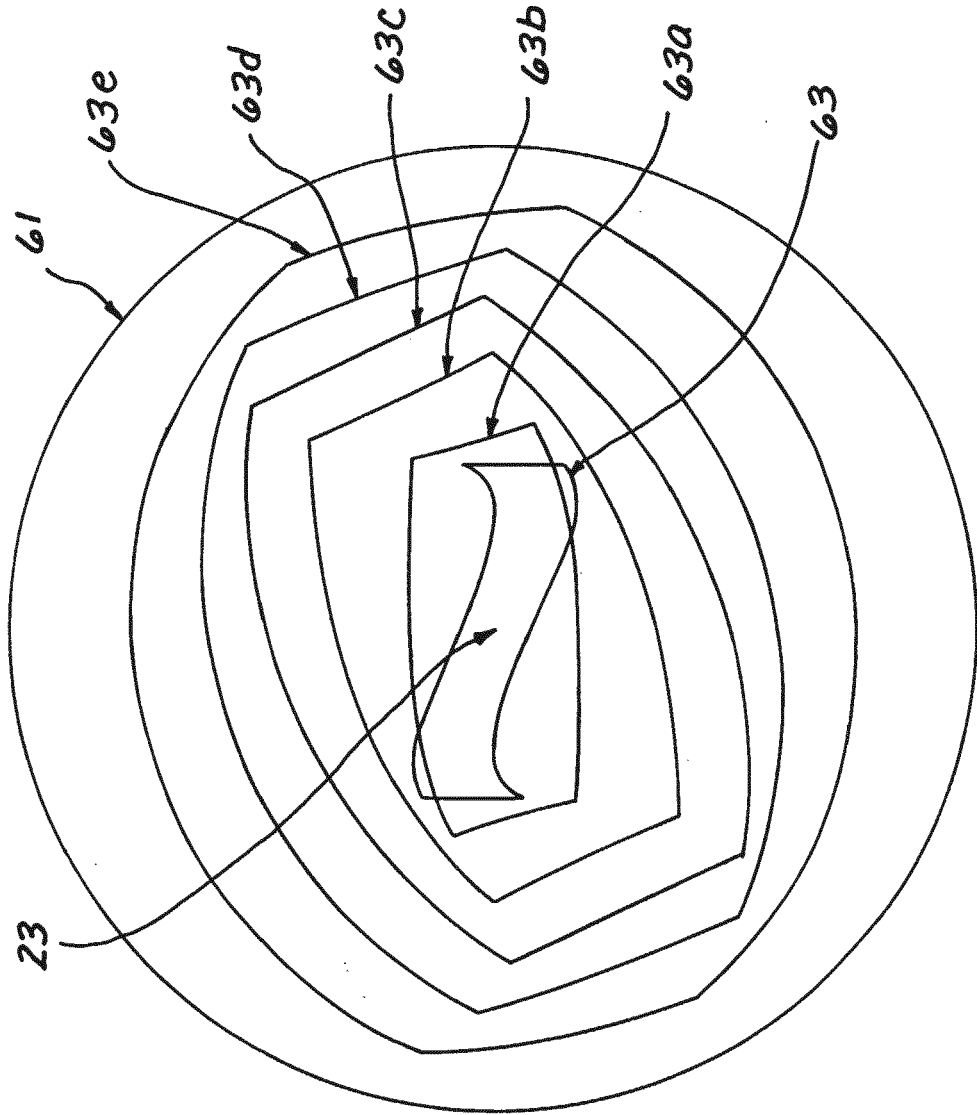
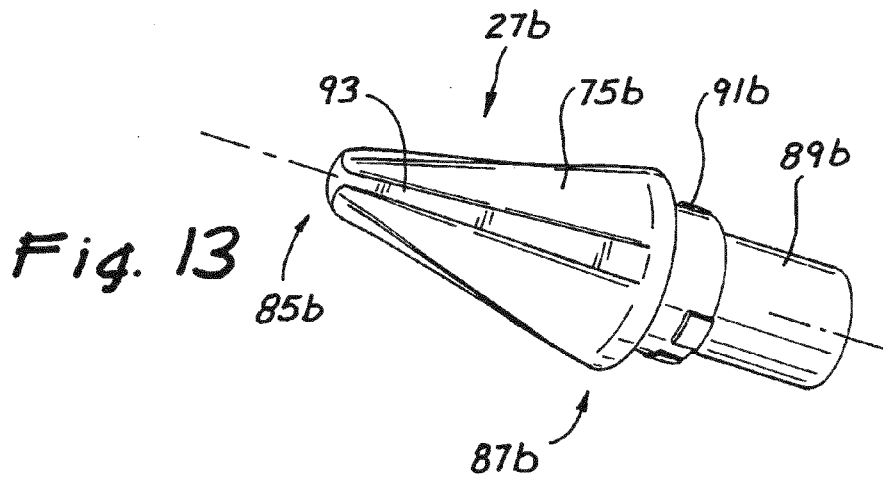
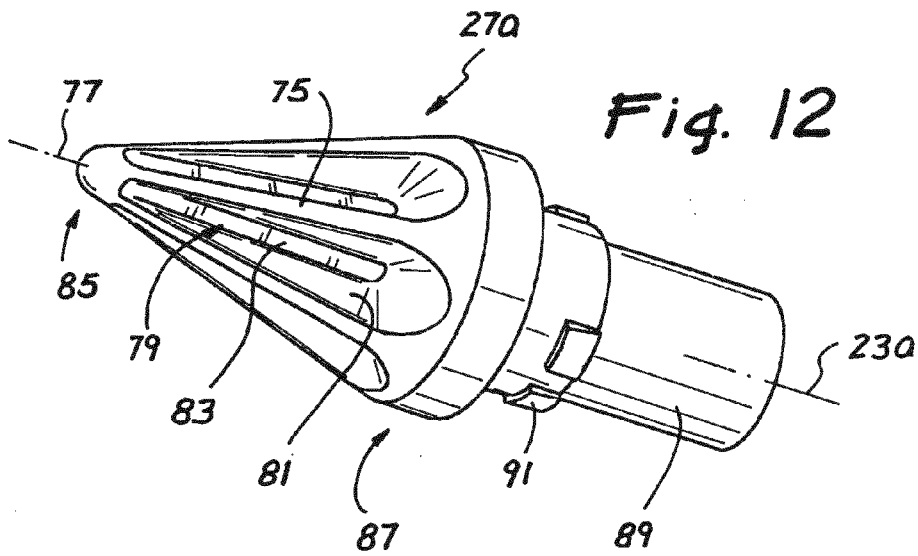
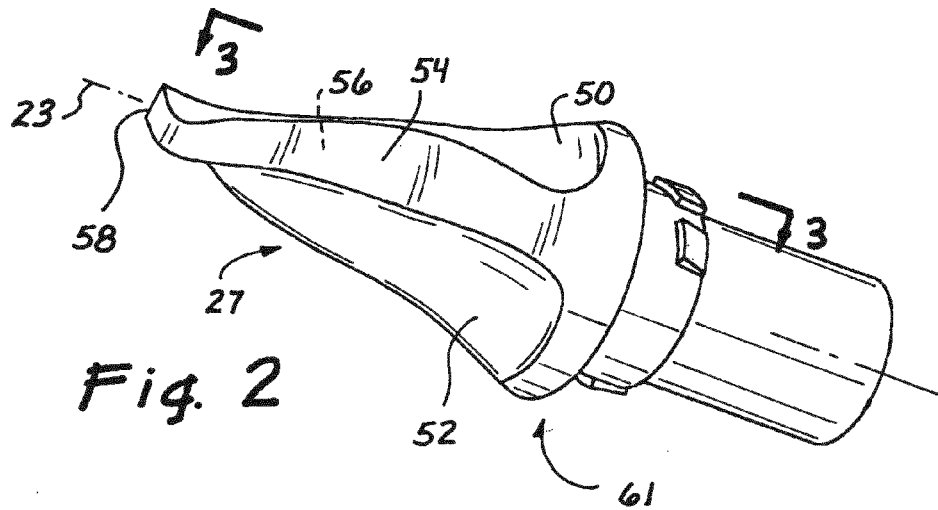

Fig. 11



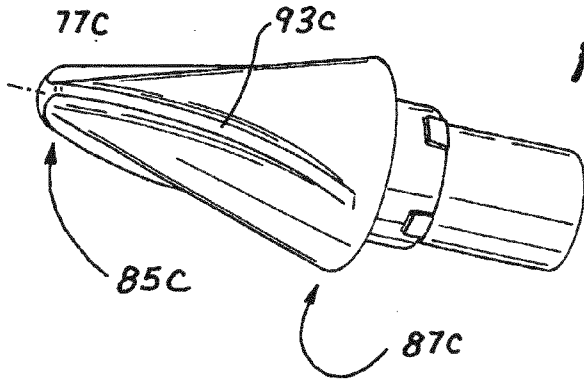

Fig. 14

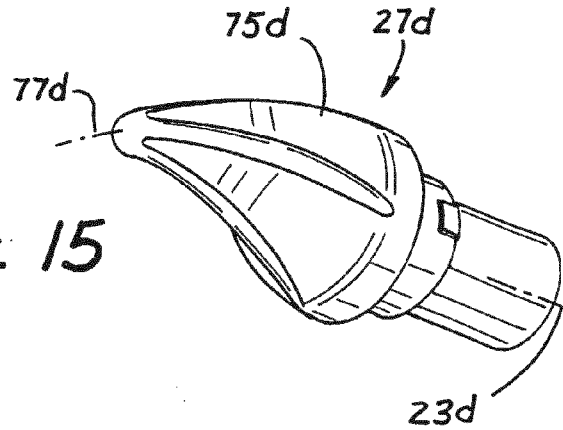

Fig. 15

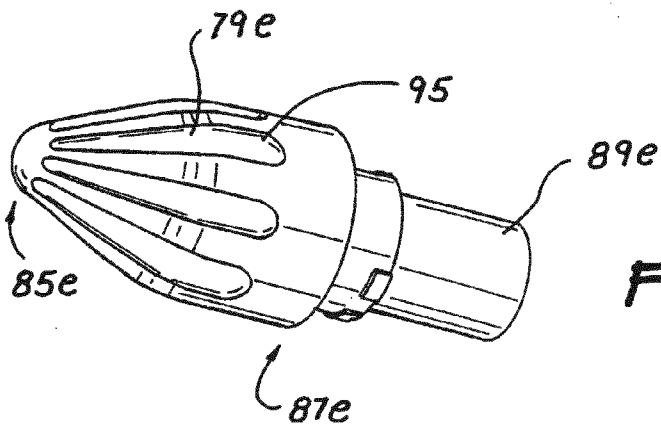

Fig. 16

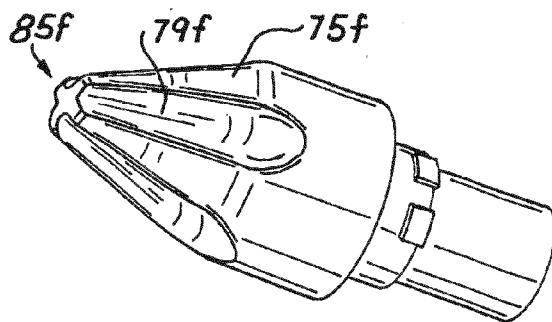
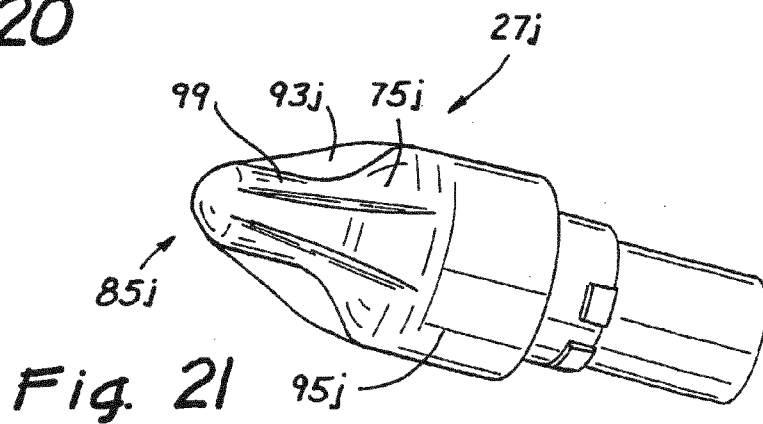
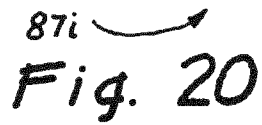
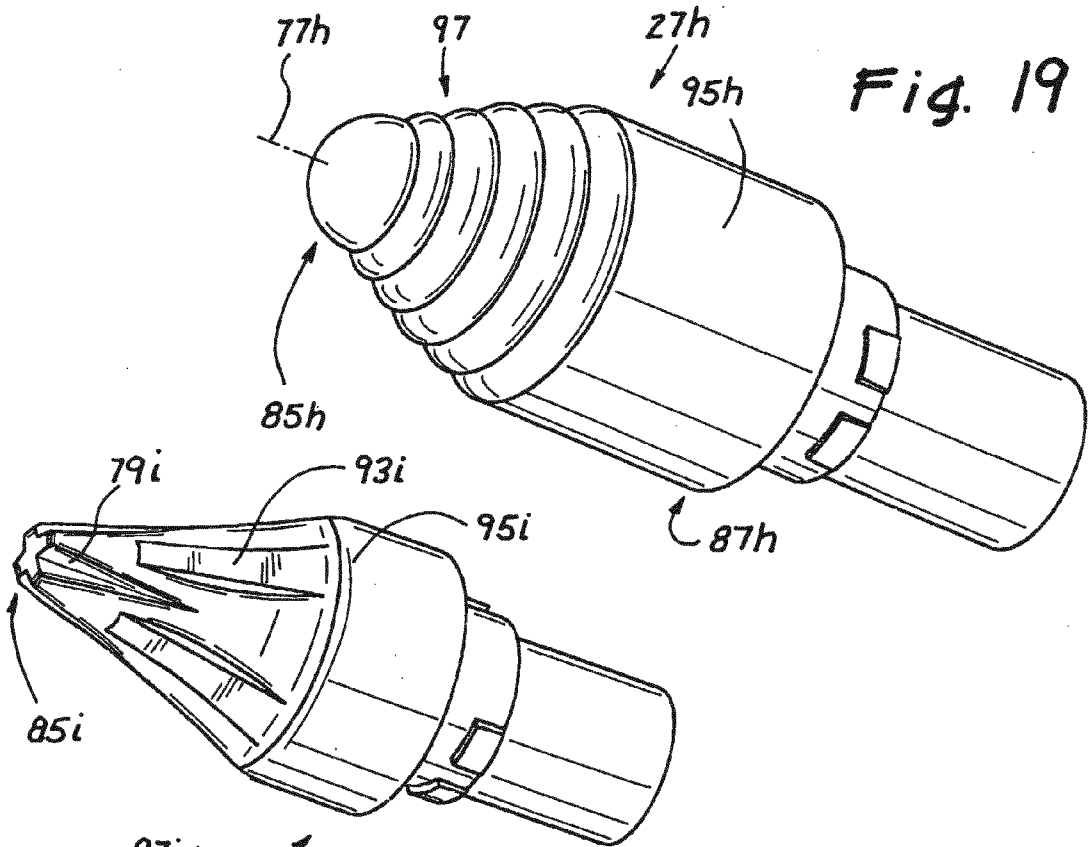
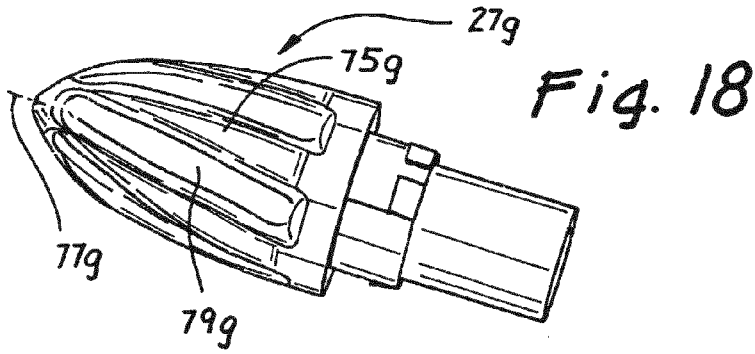
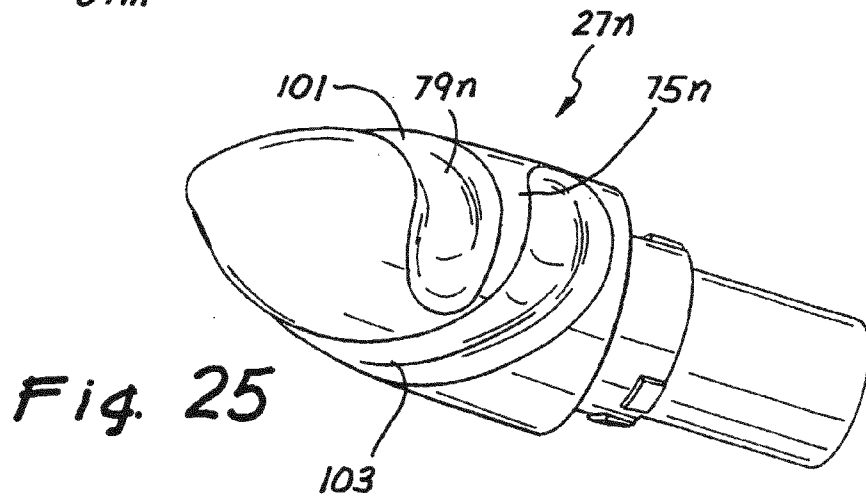
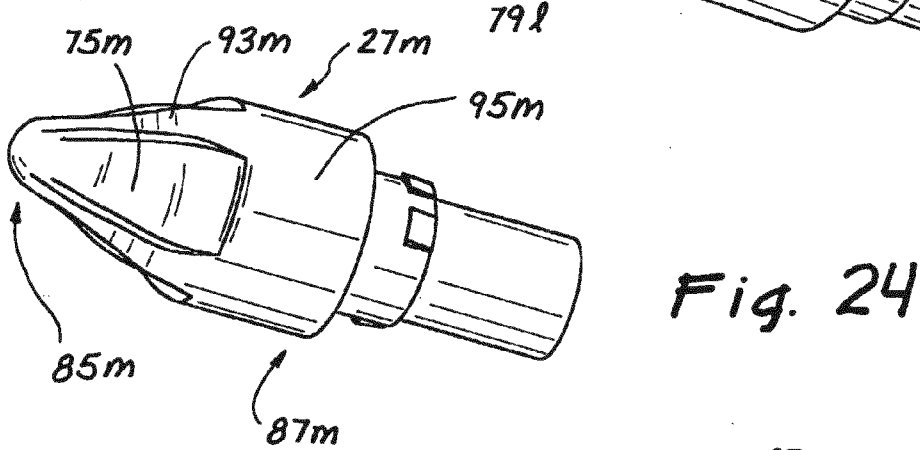
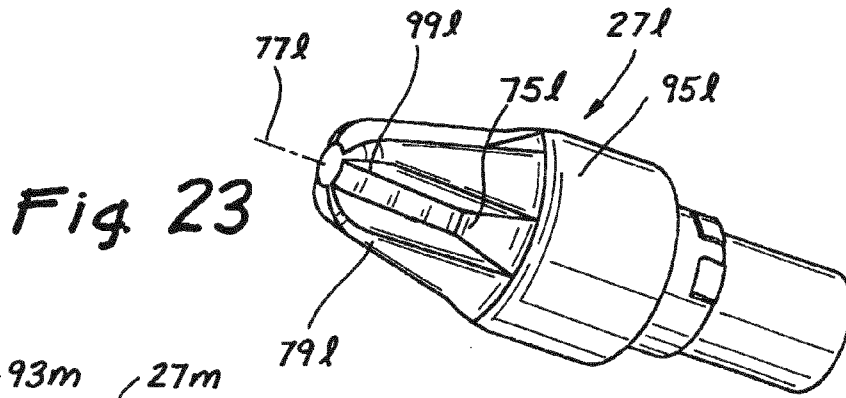
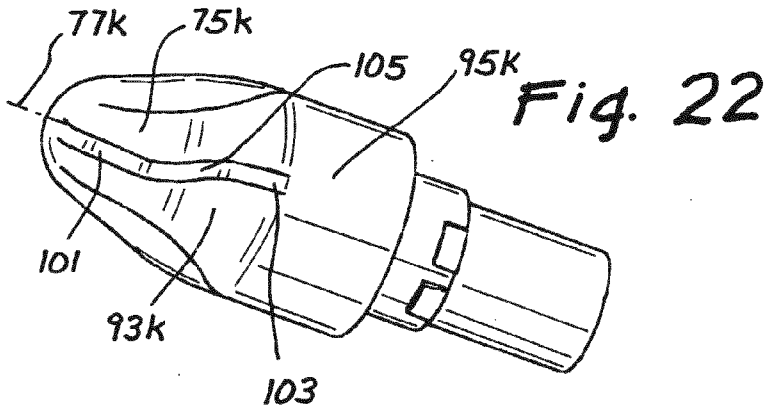

Fig. 17





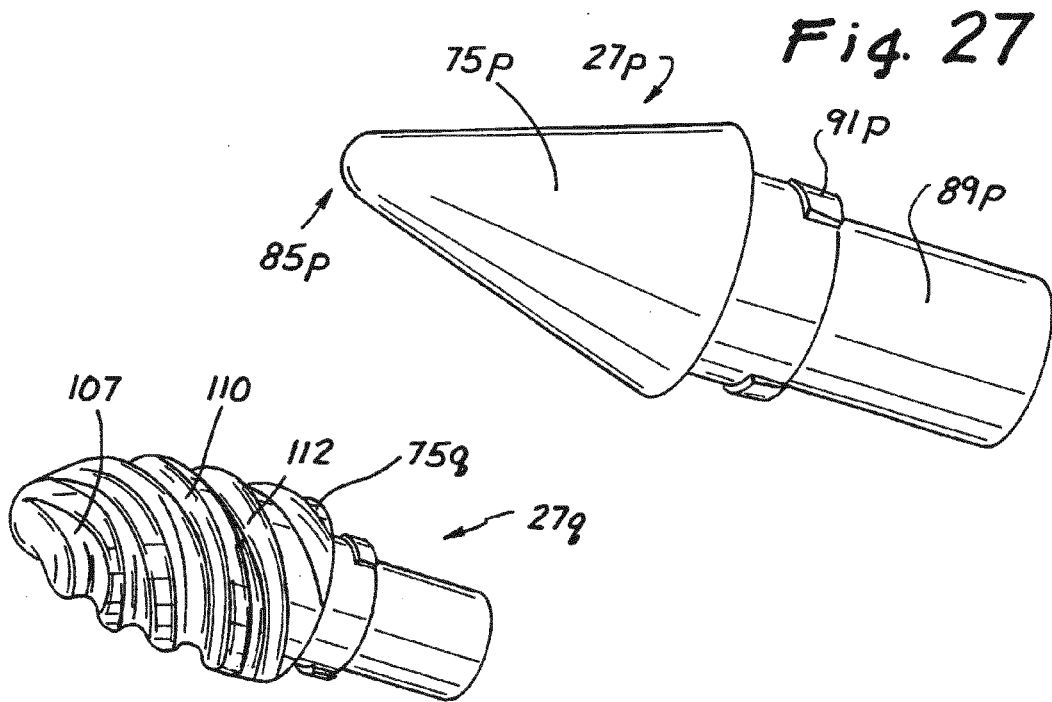
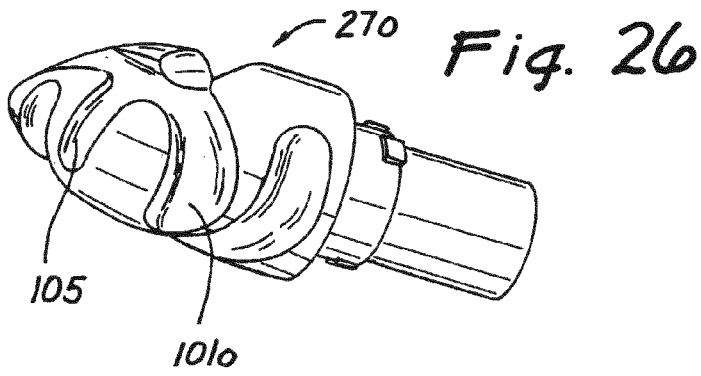

Fig. 28

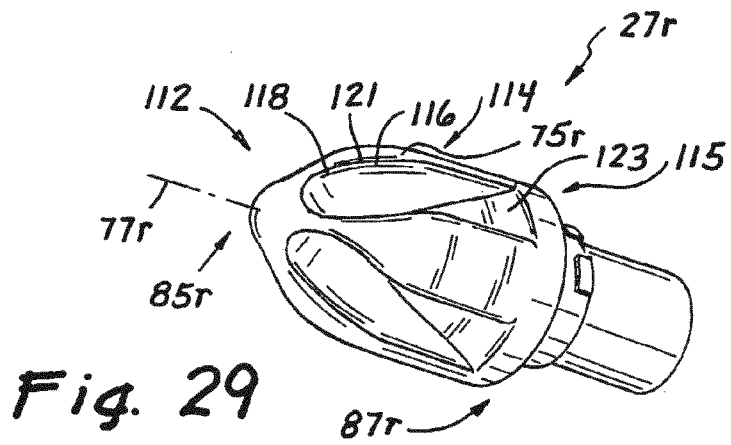
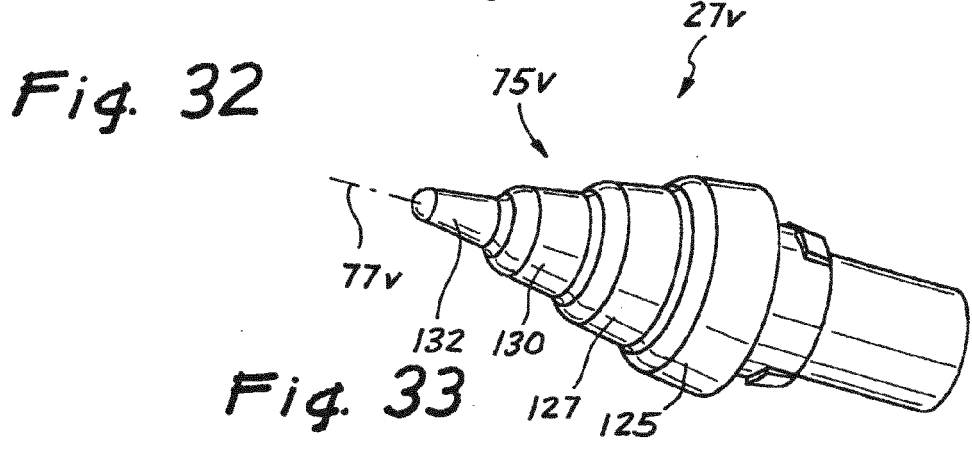
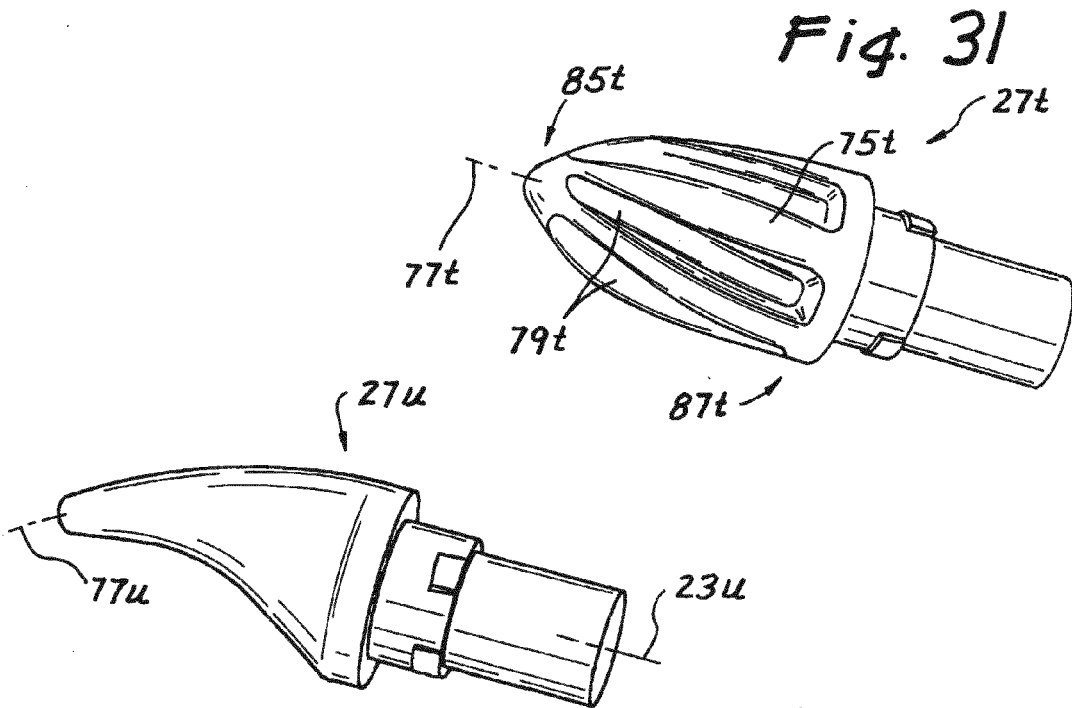
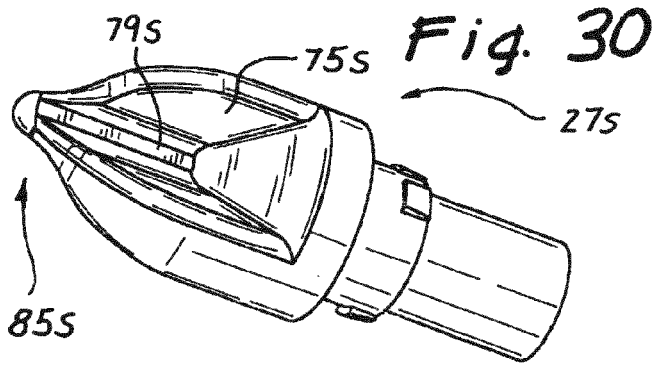
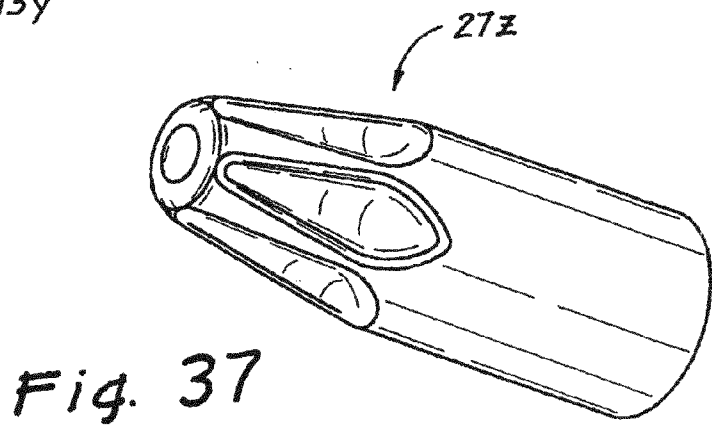
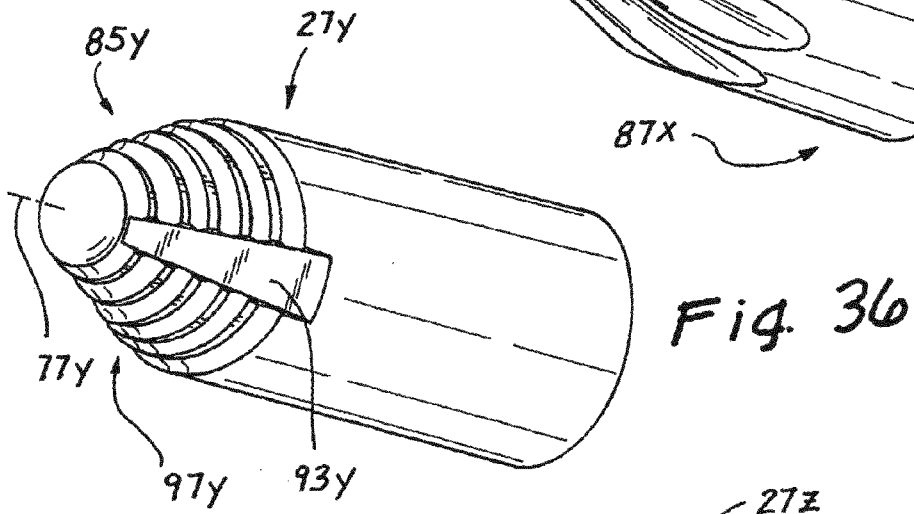
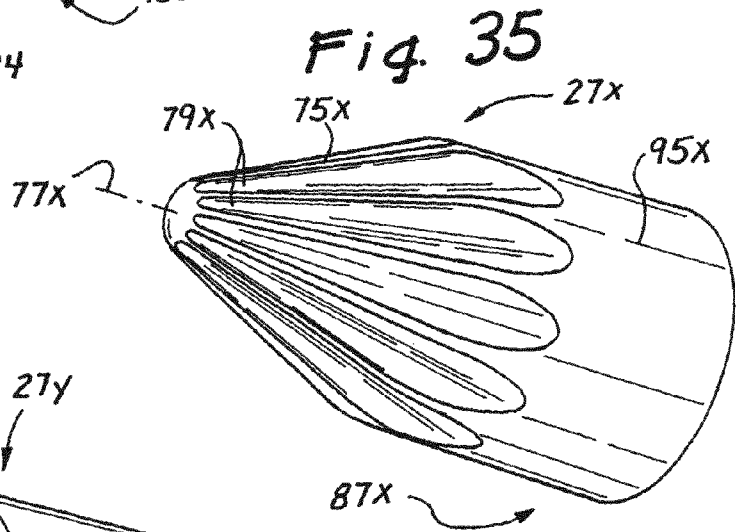
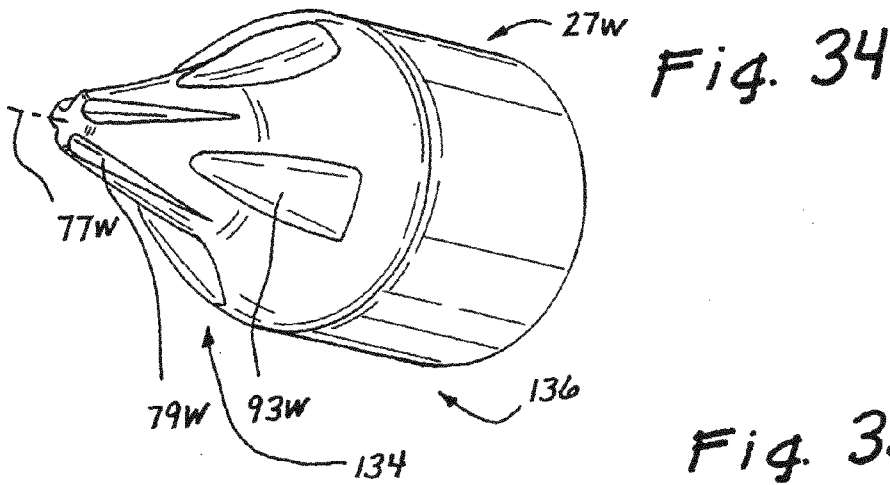

Fig. 29





REFERENCES CITED IN THE DESCRIPTION

This list of references cited by the applicant is for the reader's convenience only. It does not form part of the European patent document. Even though great care has been taken in compiling the references, errors or omissions cannot be excluded and the EPO disclaims all liability in this regard.

Patent documents cited in the description

- EP 11191187 A [0001]
- EP 02706494 A [0001]

专利名称(译)	无叶闭孔器		
公开(公告)号	EP2769683A2	公开(公告)日	2014-08-27
申请号	EP2014169569	申请日	2002-03-04
[标]申请(专利权)人(译)	应用医疗资源		
申请(专利权)人(译)	应用医疗资源CORPORATION		
当前申请(专利权)人(译)	应用医疗资源CORPORATION		
[标]发明人	PINGLETON EDWARD D WIXEY MATTHEW A KAHLE HANK		
发明人	PINGLETON, EDWARD D WIXEY, MATTHEW A KAHLE, HANK		
IPC分类号	A61B17/00 A61B17/34 A61B17/32		
CPC分类号	A61B17/02 A61B17/3417 A61B17/3478 A61B2017/320044 A61B2017/3456 A61B2017/346		
优先权	60/324613 2001-09-24 US		
其他公开文献	EP2769683B1 EP2769683A3		
外部链接	Espacenet		

摘要(译)

本发明涉及一种无刀片填塞器 (18)，用于楔入肌纤维层 (41,43,45) 以安全地切入腹腔 (32)，以便应用套管 (12)。本发明包括无刀片填塞器 (18)，其具有矩形尖端 (27j)，在两个圆柱形表面 (95j, 99j) 之间具有锥形表面 (75j)。至少一个脊 (93j) 从锥形表面和两个圆柱形表面中的远端之一径向向外延伸。

