

(19)



(11)

EP 1 804 640 B1

(12)

EUROPEAN PATENT SPECIFICATION

(45) Date of publication and mention of the grant of the patent:
23.03.2016 Bulletin 2016/12

(51) Int Cl.:
A61B 1/06 (2006.01) A61B 1/12 (2006.01)
A61B 1/005 (2006.01) A61B 17/00 (2006.01)

(21) Application number: **05802624.6**

(86) International application number:
PCT/US2005/034793

(22) Date of filing: **26.09.2005**

(87) International publication number:
WO 2006/037034 (06.04.2006 Gazette 2006/14)

(54) SOLID STATE ILLUMINATION FOR ENDOSCOPY

FESTPHASEN-BELEUCHTUNG FÜR ENDOSKOPIE

ECLAIRAGE ELECTRONIQUE POUR ENDOSCOPIE

(84) Designated Contracting States:
AT BE BG CH CY CZ DE DK EE ES FI FR GB GR HU IE IS IT LI LT LU LV MC NL PL PT RO SE SI SK TR

(72) Inventor: **Farr, Mina**
Palo Alto CA 94301 (US)

(30) Priority: **24.09.2004 US 612889 P**
23.09.2005 US 233684

(74) Representative: **Kaminski Harmann**
Patentanwälte AG
Landstrasse 124
9490 Vaduz (LI)

(43) Date of publication of application:
11.07.2007 Bulletin 2007/28

(56) References cited:
WO-A1-00/50809 US-A- 5 381 784
US-A- 5 494 483 US-A- 5 647 840
US-A1- 2002 001 202 US-A1- 2002 161 283
US-A1- 2003 120 130 US-A1- 2005 234 296
US-B1- 6 277 064

(73) Proprietor: **Farr, Mina**
Palo Alto CA 94301 (US)

EP 1 804 640 B1

Note: Within nine months of the publication of the mention of the grant of the European patent in the European Patent Bulletin, any person may give notice to the European Patent Office of opposition to that patent, in accordance with the Implementing Regulations. Notice of opposition shall not be deemed to have been filed until the opposition fee has been paid. (Art. 99(1) European Patent Convention).

Description

BACKGROUND OF THE INVENTION

1. The Field of the Invention

[0001] The present invention relates generally to apparatus for the illumination of endoscopic and borescopic fields, in minimally invasive surgical (MIS) procedures, general or diagnostic medical or industrial procedures using endoscopes or borescopes, respectively. More particularly, embodiments of the invention relate to use of Light Emitting Photodiode and other solid state light sources in endoscopic and borescopic procedures, as a means of illumination.

2. The Relevant Technology

[0002] Laparoscopy is used in both diagnostic and surgical procedures. Currently, MIS procedures, as opposed to open surgical procedures, are routinely done in almost all hospitals. Minimally invasive techniques minimize trauma to the patient by eliminating the need to make large incisions. This both reduces the risk of infection and reduces the patient's hospital stay. Laparoscopic and endoscopic procedures in MIS use different types of endoscopes as imaging means, giving the surgeon an inside-the-body view of the surgical site. Specialized endoscopes are named depending on where they are intended to look. Examples include: cystoscope (bladder), nephroscope (kidney), bronchoscope (bronchi), laryngoscope (larynx + the voice box), otoscope (ear), arthroscope (joint), laparoscope (abdomen), gastrointestinal endoscopes, and specialized stereo endoscopes used as laparoscopes or for endoscopic cardiac surgery.

[0003] The endoscope may be inserted through a tiny surgical incision to view joints or organs in the chest or abdominal cavity. More often, the endoscope is inserted into a natural body orifice such as the nose, mouth, anus, bladder or vagina. There are three basic types of endoscopes: rigid, semi-rigid, and flexible. The rigid endoscope comes in a variety of diameters and lengths depending on the requirements of the procedure. Typical endoscopic procedures require a large amount of equipment. The main equipment used in conjunction to the visual part of the endoscopic surgery are the endoscope body, fiber optics illumination bundles, illumination light source, light source controller, imaging camera, camera control module, and video display unit:

[0004] The laparoscope is a rigid endoscope as illustrated in Figure 1. It allows for visualization of the abdominopelvic cavities for diagnostic or surgical techniques. The laparoscope is inserted into the peritoneal cavity via a cannula that runs through the abdominal wall. There are many different features of laparoscopes, such as the size and field of vision, which determine the effectiveness of the instrument.

[0005] As illustrated in Figure 1, the basic laparoscope

is made up of a long thin tube 101 with an eyepiece 103 at one end for viewing into the patient. Fiber optic light introduced to the endoscope at fiber port 102, and launched into fiber optics 123 (Figure 3), passes through the endoscope body 101, illuminating the area 124 that is being observed, as illustrated by radiation pattern 125 in Figure 3. Laparoscopes are characterized by diameter and the direction of view. The direction of view is the angle 107 between the axis of the laparoscope 105 and the center field of view 106, as illustrated in Figure 1. Typical endoscopes have lengths of approximately 30 cm and diameters in the range of 4 to 10 mm. Laparoscopes consist of two important lenses, the ocular lens at the eyepiece and the objective lens 122 at the distal end of the endoscope 101 in Figure 3. Other lens sets acting as relay lenses 121 in Figure 3, are used in-between the objective lens and the eye piece or the CCD camera or image position 127. Imaging rays 126 traverse the length of the scope through all the imaging optics.

[0006] The rigid endoscope also comes in different viewing angles: 120 degree or retrograde, for viewing backward; 90 degree and 70 degree for lateral viewing; 30 degree (104 as illustrated in Figure 1) and 45 degree for forward oblique views; and 0 degree for forward viewing. The angle of the objective lens 122 used is determined by the position of the structure to be viewed.

[0007] Other surgical instruments and tools are also inserted into the body, for the operation and specific surgical manipulation by the surgeon. The insertion is done through open tubes provided inside the endoscope body for instrument insertion, such as in gastrointestinal endoscopes, or through separate incisions in the abdominal or chest wall 113, using cannula 110 (straight or curved stainless steel or plastic tubes which are inserted into a small opening or incision in the skin as illustrated in Figure 2). The cannula opening at the proximal end 112 outside the body is used to guide different instruments inside the body, where they are exposed to the inside of body at the distal end 111 of the cannula (Figure 2). Cannulas can make a seal at the incision site 114.

[0008] In a typical gastrointestinal endoscope, a tool opening is provided at the distal end of the scope, where inserted medical instruments gain access to the body following the scope body.

[0009] Endoscopes can be diagnostic, for observation only, or operative, having channels for irrigation, suction, and the insertion of accessory instruments when a surgical procedure is planned. Thus, endoscope bodies also could provide mechanical or electrical control sections, buttons for valves such as a suction valve, a CO2 valve, a water bottle connector, a water feed, a suction port, etc. The common component that all endoscopes must be equipped with is a light guide section for illumination.

[0010] An illustration showing typical endoscope optics is shown in Figure 3. Common imaging sections of the endoscope are an ocular or eyepiece, relay lenses (in the case of rigid scopes), a flexible imaging fiber-optic bundle (in the case of flexible scopes), and an objective

lens system. Endoscopes are either used as stand alone units, with the surgeon looking into the scope from the ocular or eye piece of the endoscope, or in conjunction with digital cameras, where an image of the surgical site is incident on the image capture device (charge coupled device or CCD) of the camera. Using a display device, the surgeon performs the operation looking at the image on the video monitor.

[0011] With recent technology improvements in the field of electronic imaging reducing the size of the image capture device (CCD), some endoscopes used in MIS and diagnostic procedures are equipped with a high resolution distal end camera system, commonly referred to as Chip on a Stick, one example of which is illustrated in Figure 4. These flexible endoscopes use a CCD chip 137 at the distal end of the endoscope directly capturing the image through the objective lens 131, in which case the flexible part (132) of the endoscope body, contains only power and communication wires for the CCD camera at the distal tip, rather than imaging optics 133 which is located in the rigid portion 131 of the endoscope. Light guides 138 are still necessary for this type of electronic scope to provide adequate lighting (134) of the surgical site 136 for imaging purposes.

[0012] Other, more complicated MIS systems make use of robotic surgical tools and instruments, and/or provide stereoscopic images of the surgical site for the surgeon, improving the surgeon's dexterity, precision and speed of operation. In these more sophisticated MIS imaging applications more specific types of illumination systems or multiple illuminators are used.

[0013] Endoscopes can have a variety of forms, ranging in diameter, tube length, and angle of view. However, all types of endoscopes commonly use optical fibers to illuminate the surgical site. Illumination is a very important part of laparoscopy because there is no light source inside the body. Fiber optic cold light is used to project light down the laparoscope from an external source. Large lamps with broadband output are used to couple light into the illumination light guides, where light guides transfer the illumination light from the light source to the illumination fiber bundle inside the endoscope body. A typical scope attached to an illumination light guide is shown in Figure 1. One or more light guide bundles are used to couple light into the endoscope illumination fiber bundles.

[0014] The use of fiber bundles inside the endoscope body or tube occupies space that otherwise could have been used by the imaging optics. This can be seen in Figure 3, showing the fiber optic illuminators sharing the endoscope body with the imaging optics. Limitations on the optical lens terrain diameter, as well as the imaging fiber bundle thickness, correlate directly to the imaging resolution vs. size of the image. The larger the lens diameter or imaging bundle thickness, the better the resolution of the endoscope for a certain field of view (FOV) or image size. This is the main reason that larger diameter scopes are considered better in optical quality than narrower scopes. However, large scope diameters are not

desirable for certain operations where space is limited on the operation site.

[0015] Different illumination fiber geometries are used to reduce the space constraint inside the scope body. For this reason, and to have a more uniform illumination, the imaging fiber bundles are also split in some cases to have two or more points of illumination at the distal end of the scope. In other types of scopes, illumination is made into a circular ring pattern at least at the distal end of the endoscope, similar to the ring illumination of microscopy.

[0016] The light source for the endoscope is either a xenon bulb, which creates a high intensity white light suitable for smaller-diameter endoscopes, a halogen bulb, which creates a yellowish light suitable for general endoscopic work, or a Metal Halide lamp. Since most broadband light sources also produce large amounts of Infrared Red (IR) wavelength light, IR cut filters and lamp dichroic reflectors (heat blocking filters and reflectors that reduce the radiation usually associated with heat production) are used in the illumination light source to prevent the transfer of IR radiation to the body. Thus, broadband visible cold light is highly desirable in laparoscopic procedures providing decreased thermal injury to tissues. Since most CCD cameras are also sensitive to IR radiation (due to Silicon absorption spectrum), extra IR cut filters are used in front of the camera to prevent glare caused by IR radiation in the camera.

[0017] Despite the precautions used in reducing the IR radiation, in actuality some amount of infrared radiation in addition to the visible light enters the fiber optic cable, and is transmitted through the cable and scopes into the body. When the light leaves the endoscope tip, the level of infrared radiation has usually been reduced to a safe level through absorption by the optical fibers in the endoscope, and substantial losses at the cable connections. However, if the cable is not connected to the endoscope, the infrared output is not reduced sufficiently and even could have the capability of igniting some materials if the cable is left at close proximity to absorbing combustible material. This hazard exists in fiber illumination cables with high intensity light sources.

[0018] Additionally, higher outputs not only increase the risk of fire, but may introduce the risk of burns during close-range inspection of tissue with the endoscopes. Absorption of high-intensity radiation at visible light wavelengths may also cause tissue heating, where additional filtering of infrared wavelengths may not eliminate this hazard. Furthermore, with the increasing use of television systems with video cameras connected to the endoscopes, many physicians operate light sources at their maximum intensities and believe they need even greater light intensities to compensate for inadequate illumination at peripheral areas of the image where the illumination intensity falls rather rapidly using today's standard illumination fiber guides.

[0019] Typical light sources are also deficient in their flux and color management of their spectral output. A

typical lamp spectral output requires time to come to an acceptable level during the warm-up procedure, both in terms of lumens output as well as color quality or white point on the color gamut. The color temperature of the lamp based illuminators, are typically deficient in producing the desirable color temperature (daylight color temperature of 5600 Kelvin) for typical endoscopic procedure. Color content of the lamp output also typically shifts during the life time of the lamp. Thus it is usually required to perform a white color balance adjustment in the camera controller each time an endoscope is used subsequent to the light source warm-up procedure to obtain realistic color image. A repeat of the white color balance adjustment may also be necessary if the lamp intensity is adjusted through a large range.

[0020] Typical high power lamps also have very limited life time, measured in hours (Typically 50, 500, or 1000 hours for Halogen, Xenon or Metal Halide depending on the lamp), where the light output of the lamp degrades to about one half of its original light output. Typical lamp manufacturers typically do not specify or have a failure criteria based on the color quality for the lifetime of the lamp.

[0021] Complicated and bulky optical schemes are incorporated in the light guide optical sources for effective coupling of the light into the illumination fiber bundles. Special non-imaging optics such as glass rods, and lens elements are used to also uniformly couple light into all the fibers inside the illumination fiber bundle. All these increase the cost and also size of having high brightness, uniform fiber optic illumination light sources. Typical high brightness light sources also incorporate powerful fans to dissipate the large amount of heat generated inside the light source package. In fact in a typical endoscopic procedure, light sources are one of the main sources of heat generation and the associated fans on the light sources are one of the main sources of noise in the surgical environment. Large package size of high power lamps also add extra burden to the premium space in a diagnostic and surgical environment.

[0022] Light sources normally give off electromagnetic interference (EMI), where the starting pulses from the lamp could reset or otherwise interfere with other digital electronics devices in today's surgical environment.

[0023] In an operating environment, the light source(s) are placed at a distance, on a table top or rack, mounted away from the patient and the endoscope. Fiber optic light bundles to transfer the light from the light source to the endoscope are used as light links between the light source and the endoscope. These fiber bundles are not only bulky and expensive, but their price increases by the length of the fiber bundle, whereas the amount of light transmitted goes down as the length of the fiber bundle increases. To conveniently place the light source and fiber bundle away from the operational site, longer fiber bundles are necessary, however the attenuation, or drop in the transmitted optical flux increases with the length of the fiber used as well, requiring more powerful light

sources.

[0024] Use of fiber optic light guides as a means of transfer of illumination light from the proximal to the distal end of the endoscope also increases the chance of relative light loss. The relative optical light-loss measurement quantifies the degree of light loss from the light source to the distal tip of the endoscope. The relative light loss will increase with fiber-optic damage. Extra heat will also be generated in the broken fiber ends inside the endoscope. In fact the major failure mode for the fiber optic bundles delivering the light to the endoscope, and the optical system inside the endoscope is breakage of the fibers.

[0025] As illustrated in Figure 1, the illumination fiber bundle(s) 102 commonly join the endoscope body at some angle near the ocular (103) at the proximal side of the endoscope. The fiber guide body and the main endoscope body are commonly joined together in a welding process at joint 108 illustrated in Figure 1. The construction and design of this welded joint is often a weakness in the endoscope manufacturing and use, where after many operations, high temperature and high humidity sterilizations, and successive handling, this welded joint could get damaged and break, exposing the internal parts of the scope to the environment when the seal is broken.

[0026] Color CCD cameras use alternate color dies on the individual CCD pixels, to capture color images. Green and red, and green and blue pixels are alternated in rows. This spatial color sampling limits the color resolution of the color CCD cameras, since each pixel is dedicated to capturing a single color in the color image.

[0027] 3 chip CCD cameras (red CCD chip, blue CCD chip, and green CCD chip) are also used in high resolution applications, where all the pixels in each CCD are dedicated to detecting the single color content of the image. The individual color captured images from the 3 CCDs are then put together electronically, as the multi-color image is reproduced on the viewing display. Three chip CCD cameras are expensive and bulky.

[0028] US 2003/120130 A1 relates to an endoscope having a tubular body with a distal end and a proximal end provided to be inserted with its distal end at least partially into a lumen and having a sensing device changeably connected to the distal end of the tubular body. The tubular body may be flexible or rigid. The sensing device is provided with an image sensor, such as a CCD or a CMOS sensor and optionally further sensors. It further comprises a light source, such as a LED and a transmitter for transmitting image data or other data to a receiving unit. These elements of the sensing device are powered by a battery contained in the sensing device or by means of an electrical wire connection. In a first mode the sensing device is connected to the distal end of the tube to substantially form a continuum along the longitudinal axis of the tube. In a second mode the sensing device is connected to the distal end of the tube essentially in parallel to the longitudinal axis of the tube. Movement of the sensing device from first mode into second

mode is managed, i.e. by means of a wire which is movable via a control.

[0029] WO 00/50809 A1 relates to a lightning device preferably used together with a surgical instrument in order to illuminate a lumen within a patient. The lightning device comprises a light distributor for receiving light from a light source and propagating light therethrough via internal reflection, a light emitter for receiving propagated light from the light distributor and emitting directional light from a free end of the light emitter. It further comprises a sleeve having an aperture spaced from said free end of the distributor through which the directional light is beamed. The light source can be a Xenon lamp as well as a LED or multiple white or colored LED. The distributor can be an optic light pipe. The transmitter can comprise one of the following transparent, translucent materials: acrylic, polycarbonate, glass, epoxy or any other suitable resin, it can be flat, curved, flexible or rigid, comprising prism or other devices in order to direct or diffuse light according to the requirements. In a particular embodiment the emitter is formed like a spring-formed "grope" lightning device. That means the emitter at the end of the lightning device is formed like a hook or an open ring. The hook is flexible and can be pressed in a more oval form in order to insert it through a small aperture into a lumen which has to be illuminated. Because it is formed of a flexible material, it returns to its original hook or open ring form after being compressed during insertion into the lumen.

BRIEF DESCRIPTION OF THE DRAWINGS

[0030] To further clarify the above and features of the present invention, a more particular description of the invention will be rendered by reference to specific embodiments thereof which are illustrated in the appended drawings. It is appreciated that these drawings depict only typical embodiments of the invention and are therefore not to be considered limiting of its scope. The invention is defined in claim 1 and will be described and explained with additional specificity and detail through the use of the accompanying drawings in which:

Figure 1 illustrates a typical angled endoscope, with fiber optic light port for illumination, and an eye piece for viewing;

Figure 2 illustrates a cannula inserted into the body cavity.

Figure 3 illustrates the cross section of a typical zero degree, rigid endoscope with associated terrain for relay of the image through the length of the endoscope.;

Figure 4 illustrates the cross section of a zero degree typical flexible endoscope body (Chip on the Stick) with fiber optics illumination;

Figures 5a to 5d illustrate various single LED sources, without and with various encapsulation optics;

Figures 6a and 6b illustrate a self lighted cannula

using multiple LED sources installed at the proximal end of the cannula;

Figure 7 illustrates a cannula body used as the illuminator for inside the body cavity;

Figure 8 illustrates a cannula with built in LED illuminators at the distal end of the cannula;

Figures 9a and 9b illustrate an angled endoscope with modified distal tip, incorporating an array of LEDs for illumination of the surgical site;

Figure 10 illustrates fixed solid state illuminators assembled behind the first negative lens of the endoscope, used as window at the distal end of a flexible endoscope;

Figures 11a and 11b illustrate inclusion of the LED sources within the objective lens of an endoscope, using a beam splitter;

Figures 12a and 12b illustrate insertion and deployment of a flexible membrane with built in LED illuminators, to light the surgical area inside the body, according to the invention;

Figures 13a and 13b illustrate possible deployment of LED illuminators at the distal end of a flexible endoscope;

Figures 14a and 14b illustrate possible deployment of LED illuminators stored within the objective lens of a flexible endoscope;

Figures 15a and 15b illustrate possible deployment of LED illuminators stored next to the objective lens of a rigid body endoscope;

Figures 16a and 16b illustrate possible deployment of LED illuminators stored along the distal tip of a rigid body endoscope;

Figures 17a, 17b, and 17c illustrate LED illuminators built into the body of a surgical instrument or tool, with possible deployment during operation to illuminate the surgical site;

Figures 18a and 18b illustrate LED illuminators positioned beyond the distal end of the endoscopes, with possible deployment clearing line of site in the imaging optics; and

Figures 19a and 19b illustrate LED array illuminators built into physically separate body, insertable and deployable inside the body of an endoscope.

45 DETAILED DESCRIPTION OF THE EXEMPLARY EMBODIMENTS

[0031] Exemplary embodiments of the invention concern monochromatic or polychromatic solid state light sources such as high power Light Emitting Devices (LEDs) and Laser Diodes as a means of illumination in a diagnostic or surgical endoscopic procedures, or functional borescopic systems. In particular, these solid state light sources are incorporated at the distal end of the endoscope, borescope, surgical or industrial tools, and the tip end of cannulas and other functional devices. They can also be incorporated in an illumination body that is inserted separately, or in conjunction with a lighted or

dark scope, into the body. The illumination of an object inside a body, a body herein being defined as at least a portion of a human, animal or physical object not easily accessible, is performed to detect the modified light, image the object, or manipulate a change in the object. The solid state illumination schemes of the present invention can replace, or can be used in addition to, the conventional fiber optic illumination system and other diagnostic devices such as ultrasound imaging used in endoscopy and borescopy..

[0032] Use of such solid state sources inside a cavity in the body, replaces variety of instruments otherwise needed for the same purpose, such as an external light source, fiber light guides, and means of transmitting the light to the desired object.

[0033] Exemplarily, the use of LED sources has several advantages over the conventional external white light source. With an LED based illumination, a true, visible light source with no IR content is available for the endoscopic application. Therefore, the complicated IR management of the light source is eliminated. There is no longer a fire hazard associated with light guides that may be left on, and no heat management inside the scope is needed.

[0034] LEDs can provide light at any region of the visible spectrum. Red, Green, and Blue LEDs in primary colors can be used together to form a white illumination, Phosphor-converted LEDs can provide white output directly without any color mixing, Infra Red (IR) or Ultraviolet (UV) LEDs can be used for their special characteristic in light transmission in the medium of insertion or the effect they have on the object of interest.

[0035] LED lifetimes are more than order of magnitude longer than bulb type light sources(50k hours depending on the drive condition). The long life time in conjunction with the reliability associated with solid state lighting practically illuminates any lamp outages in an MIS procedure, where dependable illumination is one of the most critical parts of the system. In fact LED life time is more in line with the usage life time of most MIS surgical tools.

[0036] LED power consumption is also much lower than high power light sources. The LED illumination system is most efficient since there is no need for i) transferring light from the source through fiber optic light guides, ii) coupling the light into the scope light guides, or iii) transmitting through the fiber optic light guides through bends in the fiber. Light powers in the order of 1000 lumens are in fact possible with use of few high power LEDs.

[0037] Further, LEDs are robust, and do not break, unlike fiber optic light guides. Properly encapsulated LEDs, can withstand severe environmental conditions and cleaning procedures.

[0038] LEDs do not produce any electromagnetic interference, thus eliminating the need for complicated EMI management system such as Faraday caging. Because of size, reliability and safety of LEDs, these light sources are ideal choice for "in location" illumination of the object

inside the body. Where only electrical power is transmitted to the light source inside the body along with possible electrical control signals.

[0039] By eliminating conventional fiber optic illumination guides inside the endoscope body, there is more space for the imaging optics or imaging fibers, where the size directly relates to the image information transfer capability of the system. With more space available to the imaging optics, larger diameter optics and imaging fiber diameters can be used, making larger image FOVs and higher resolution possible.

[0040] LEDs do not require a warm-up procedure. LEDs are capable of providing instant illumination with the exact color point at initiation. Optical power and color maintenance over the life time of the LED are also critical features of solid state light sources.

[0041] By using three color LEDs (red, green and blue) and synchronizing a black and white camera system to grab the three synchronized color component images, the use of color camera chips or the high resolution 3 CCD chip cameras is eliminated. Since a single CCD camera is used to capture the three images in a time synchronized fashion, each color component image takes advantage of the full CCD image resolution by incorporating all the pixels in each color image component. Two examples of exemplary embodiments of endoscopes having LED illuminators and CCD image cameras are shown in Figure 4. Simple black and white CCD or CMOS camera chips are also cheaper to use, especially compared to a 3 chip CCD camera, where in effect the resolution of the synchronized black and white imaging CCD using synchronized color illumination provided by the LEDs is equivalent to a same pixel 3 CCD chip camera.

[0042] Using the color synchronized image capture device also allows the use of much higher resolution image capture devices in chip on the stick cameras where space is limited at the distal tip of the endoscope for the image capture CCD. A variety of illumination configurations are possible using LED chips, where the uniformity, angle and extent of the illumination are freely controlled by the positioning and design of the LED light sources.

[0043] Other optoelectronic devices can also be suitable for use with the imaging, detecting, or manipulating device disclosed herein. For example, a photodiode may replace or be used in conjunction with a solid state light source for any of the embodiments shown herein. Thus, as used herein, the term "solid state optoelectronic element" will refer to both solid state devices that emit light as well as those that detect light.

[0044] Figures 5a through 5d illustrate various configurations of LED output. Figure 5a depicts a LED 140 disposed on a base 141. The LED 140 is unencapsulated resulting in output in the form of a Lambertian light source. This makes these solid state light sources ideal for endoscopic illumination applications where wide angular field of view needs to be properly illuminated.

[0045] A simple lensing element can also be used in

the form of an LED encapsulant, where depending on the shape of the lens surface and the lens' distance from the LED surface, different angular illuminations or focusing of the light can be easily accomplished. Figure 5b illustrates a simple lens encapsulation 143 maintaining the same Lambertian light output as the unencapsulated LED, however with much higher light extraction from the LED chip.

[0046] Figure 5c depicts an alternate surface structure for the LED encapsulation, such as fresnel lens profile 144, diffractive optics or other refractive profiles can yield different angular extent of the encapsulated LED radiation pattern 144.

[0047] Figure 5d illustrates a simple lens encapsulation where higher index encapsulation material is used in conjunction with positioning the lens surface farther away than the lens radius or curvature resulting in a substantial decrease in the angular extent of the radiation pattern 146 can be achieved.

[0048] With controllable illumination color available to 3 color LEDs, the color gamut of the illumination can be changed according to the application using the drive condition for the independent color LEDs. This is highly desirable where the information content of the surgical site is mainly in a certain color, and where shifting the illumination color can increase the visibility and differentiation needed in diagnostic evaluation of the surgical scene.

[0049] Using more illumination sources with other wavelengths than the three primary illumination colors, and matching the image detection frame capture sequence to that of the synchronized color illumination sources, allows higher quality image capture in terms of more realistic colors. Using only primary RGB colors the detected image color content is within the color triangle in the CIE color diagram. Adding LEDs with other colors such as amber, cyan, and magenta, increases the detected color gamut of the image substantially. With the recent color displays such as flat panel LCD displays using more than just primary color illuminators (such as with 6 LED back light illuminators), it is in fact possible to present a "true color" image to the operator that was never before possible with the 3 color LED CCD cameras. This can be important in certain surgical applications where the color reproduction integrity plays an important role in the surgeon's perception of the scene or diagnosis of the object.

[0050] LED illumination systems are modular, where one or multiple illumination systems can be inserted into the body independent of one another, via separate illumination bodies, at the distal end of an endoscope, or incorporated at convenient and efficient locations on surgical tool tips or cannulas.

[0051] Different solid state light sources or combination of these sources can be used to perform diagnostic as well as surgical or other functions on a body. A variety of illuminators can work in conjunction with one another and other devices to image, detect or modify the object.

[0052] One example of an embodiment of an LED illu-

minator 150 not according to the present invention used in a cannula is illustrated in Figures 6a and 6b. In this exemplary embodiment, the body of the cannula which is clear to the light in the visible spectrum is completely lit by white or color LEDs 151 mounted at the proximal end 112 of the cannula. Electrical power to the LEDs is provided by power connection 152. As illustrated in Figure 6b, the LED light fed into the cannula body goes through Total Internal Reflection as it travels the length of the cannula to the distal end 111, at which point the light leaves the cannula illuminating the surgical site and tools as indicated by radiation pattern 154.

[0053] In an alternative embodiment if a cannula 160 depicted in Figure 7, the cannula body includes near its distal end 111 surface mount white or color LEDs 161. A cone type reflective cover (not shown) for these LEDs 161 can also be inserted along with the cannula 160 into the body, where the LED light from the body of the cannula is directed more towards the distal end of the cannula.

[0054] Figure 8 illustrates another simple embodiment of a cannula 170 with white or color LEDs 171 mounted directly at the distal end 111 of the cannula 170.

[0055] As depicted in Figures 9a and 9b, in an exemplary embodiment of an LED illuminated endoscope 180, an array of white or color LED illuminators 181 is built into an extension portion 181a extending from the distal tip of an angled endoscope tube 101. The array of LEDs 181 can be encapsulated with lens elements 182 to establish the desired illumination field and uniformity 184. Figure 9a illustrates this exemplary embodiment of endoscope 101 in the side view, and Figure 9b is an end view illustration of such embodiment. Clear imaging port is noted as 183 on these figures, and the LEDs are encapsulated using a Fresnel type lens structure 182. Other tool insertion ports, multiple imaging ports for stereo imaging, or imaging ports with various Field of View (FOV), can be used in the clear area of the distal end of the endoscope. Other solid state light sources such as laser diodes or various wavelength LEDs can be mounted in the vicinity of the LED sources depicted in this embodiment to perform other functions using the same device. Other forms of optics or optical elements such as lenses, polarizers and wave-plates can also be used in front of the illuminators or detection ports to modify the illumination extent or for proper detection of the light

[0056] In another embodiment of a solid state illumination within an endoscope 190, Figure 10 illustrates the incorporation of white, color LEDs or lasers, IR or UV solid state light sources 191 behind the first negative lens 193 of the objective lens 131. This portion of the objective lens in effect acts as a window for the illumination source 191, since the concave portion of the first negative lens of the objective, is typically much smaller than the distal window of the scope. Solid state illumination sources in this configuration can be directly mounted to this glass window around the concave area of the lens. As the illumination light leaves the glass at the distal end, the an-

gular radiation pattern 192 of the light expands as illumination is emitted outside the glass. Refractive, polarization, or wave-plates can also be implemented in the area of the negative lens beyond the concave portion to modify the illumination characteristic.

[0057] In yet another embodiment of LED illumination within the endoscope 200, white or combination of RGB LEDs can be used within the objective lens 131. As illustrated in Figure 11a, LEDs 201 can be mounted so that the illumination crosses the endoscope axis where the illumination light from the LEDs is combined into the imaging path using beam splitter optics 202.

[0058] Figure 11b illustrates an alternative positioning of the LED 203 within the objective lens 131 in LED illuminated endoscope 200, without the use of a beam splitter. Light emitted by the LEDs in this geometry pass through the distal portion of the objective lens, illuminating the surgical site through the same window as the endoscope imaging optics.

[0059] LEDs provide a desirable cost advantage over conventional lamp and fiber guide systems, as it replaces the expensive light sources, long fiber optic light guides to transfer light from the light source to the scope, and the illumination light guides inside the scope as well. Low level power is only needed for the LED light sources, thus the electrical connection of the LEDs is much easier.

[0060] Only electrical power and LED control signals need to be provided for the endoscope, eliminating the heavy and bulky fiber optics illumination cable connection to the scope, increasing the maneuverability of the endoscope. LED illumination systems are also more robust to shock and vibrations or extreme environmental conditions than fiber optic illumination systems.

[0061] Since any heat generated from the LEDs is not in the form of radiative heat, as in the case of lamps, it can be easily conducted out of the endoscope, or instrument tip using a conductive layer or the endoscope or instrument body itself. Some of this heat can in fact be conducted towards the endoscope optical window, such as in the embodiment of Figure 10 which shows endoscope 190, where the LEDs 191 are at intimate contact with the endoscope window and its holder, which provides the proper temperature setting to avoid any condensation on the optical window during operation and additionally warms the end of the cold endoscope when it is inserted into the warm and humid body cavity. In turn a separate low power infrared LED can also be used for the purpose of heating the endoscope tip.

[0062] In another embodiment, channels containing cooling fluid can be formed in the body of the endoscope or instrument and near the light-emitting solid state light source to conduct heat away from the distal end of the device to the proximal end that is outside the body.

[0063] In addition to the above exemplary embodiments 180, 190 and 200, where the LED illuminators are used in fixed positions within the endoscope body, other deployable embodiments are possible for effective illumination of the surgical site. In these deployable embod-

iments, the LED illuminators are deployable from an insertion position in which they are held within the insertion body or within a close profile of the insertion body, to an operational position where they are conveniently pointed to the object of interest. In operational position, the illumination light can be directed to the surgical site from beyond the endoscope body, where deployment of the LED holder structure positions the illuminators off axis from the imaging axis, possibly increasing the collection efficiency of the imaging optics.

[0064] In some exemplary embodiments, this deployment can be accomplished using, by way of example and not limitation, an umbrella type deployment structure capable of being opened and closed by an operator. Different variations of this umbrella structure can be used depending on the desired application, amount of illumination, and light positioning requirement Figure 12a illustrates one example of an umbrella-type deployment structure where an LED-supporting structure is deployed through a cannula. A circular flexible membrane 381 is populated with white or color LEDs 382 This populated membrane 181 includes a spring at its peripheral section (circular edge) of the membrane body. The membrane 381 is deployably coupled to the distal end 111 of the cannula. In the insertion position, the membrane is collapsed into a tube form 381a. Once the collapsed membrane 381a is maneuvered to the desired location, the membrane is fully deployed until it is outside the distal end 111 of the cannula. The spring action at the membrane's edge forces the membrane to open into a flat surface 381b. LEDs 382 illuminate the surgical site or other tools and instruments inserted into the body.

[0065] Figures 13a and 13b illustrate another embodiment of dynamic deployment of LED illuminators. In Figure 13a, LED illuminators 210a are disposed via rotational hinges on the endoscope, such that the axis of hinges (forming deployment hinge axes 213 and 214) are orthogonal to the longitudinal axis of the endoscope. LED illuminators 210a in their "off" or insertion position, where deployment cables 211 and 212 placed around deployment hinge axis 213 and 214 in a neutral position. In order to deploy LEDs 210a, the illuminators 210 are flipped over the endoscope tip by pulling on one side of the deployment cables 211 and 212 that run around the deployment hinge axis 213 and 214. Once the illuminator 210b is deployed ("on" position) the 210b LEDs are flipped into position around the endoscope distal tip as shown in Figure 13b.

[0066] In another embodiment of deployable LED illumination, Figure 14a represents an "off" position for the LED illuminators 220a as they are stored within the endoscope objective lens free cavity. In an "on" position, LEDs 220b are deployed in a circular manner, rotating outside the objective lens cavity of the endoscope.

[0067] Figures 15a and 15b, represent another scheme in storing 231a LEDs in their "off" position, next to the objective lens at the distal end 230 of the endoscope. LEDs 231a are disposed on a hinge portion 232. The

hinge portion 232 is, in turn, connected to an actuation portion 233. The LEDs 231a are deployed into position as the actuation portion 233 is pushed distally in the direction of the arrows towards the distal tip of the endoscope. Such action deploys the hinge portion 232 which positions the LEDs 231b to emit light that is off-axis from the imaging optics.

[0068] In an alternate configuration, represented in Figures 16a and 16b, another type of deployment mechanism is used. The LEDs 241a are disposed on hinge portion 242. The hinge portion 242 is, in turn, connected to an actuation portion 243. The LEDs 241a are deployed into positions by pulling the actuation portion 243 proximally in the direction of the arrows toward the proximal end of the endoscope, deploying the LEDs 241b into their "on" position.

[0069] Figures 17a through 17c illustrate an exemplary embodiment of LED illumination in conjunction with a surgical tool. Figure 17a and 17b are side views of the surgical tool in an illumination "off" position where cables 253 and 254 used for deployment are in their neutral position. Figure 17b shows each LED 252a are disposed on the surgical tool via a rotational axis 255, 256. A cable 253 is disposed on rotational axes 255 and a cable 254 is disposed on rotational axes 256. As shown in Figure 17a, cable 253 includes a first side 253a and a second side 253b that can be lengthened simultaneously by pulling about the rotational axes 255. Figure 17c illustrates a surgical tool in an illumination or deployed "on" position, where LEDs illuminators 252b and 253b are opened up from the stored position to illuminate the surgical work area, by pulling one of the sides of the cables 253 and 254 that are disposed about the rotational hinge axis 255 and 256.

[0070] Figures 18a and 18b illustrate another exemplary embodiment of LED illumination on a triple port endoscope where ports 262a and 262b are for possible stereo imaging, and port 263 is possibly to access a larger field of view using wide angle lenses. Illumination bodies 261a and 261b represent arrays of solid state devices such as LEDs, Laser Diodes or combination of light sources and detectors. These devices are functionally rotationally deployable at the end of the endoscope, where the rotational deployment axis (264a and 264b) are parallel to the endoscope longitudinal axis. In a possible deployment scheme depicted in Figures 18a and 18b, cables 265a and 265b run through the device to the proximal end and are attached to the back of the illuminator bodies 261a and 261b. For deployment these cables are pulled along towards the proximal end, actuating the illuminator bodies from their neutral position to their deployed position. It will be appreciated that in this and any embodiment where the solid state electro-optic elements are deployable that more than one rotational axis may be implemented in order to provide more robotic forms of movement and manipulation. These sources or detectors are used to perform, help diagnose or perform surgical functions as necessary. Optical components to

collimate, focus or to capture light in form of a single or multiple refractive or diffractive elements can be used in front of the array as appropriate along with other optical components such as polarizers, pinholes, slits, or waveplates. The rotational deployment of the illuminator bodies 261 a and 261b, can be done in such manner that allows the insertion of the endoscope inside the body in the closed position and active use of the devices in the deployed position.

[0071] In all deployable embodiments, the LED illuminations can be encapsulated with plastic material for a single use purpose, where the deployable body is plugged into the device and is disposed of after use.

[0072] Figures 19a and 19b, represent yet another deployable array of devices 271a and 271b, where the direction of deployment and the rotation axis 274 are at an orthogonal direction to that of the longitudinal axis of the endoscope body. In this exemplary embodiment, the deployable illuminator body 275 is made as a separate body, is inserted into the hole 276 in the endoscope body 101, before insertion into the cannula. The deployable illuminator can be made as a reusable or a disposable unit. The solid state illuminators 271a, 271b can be deployed using actuating members similar to other embodiments described herein.

[0073] In alternate embodiments of all of the endoscopes, cannulas and other devices described above that use LEDs for illumination, Solid State Laser Diodes (LD) can also be used at the distal end of tools, insertion tubes, catheters, imaging scopes, cannulas, etc. Infrared Imaging could use IR solid state light sources to illuminate intra-vein or close tissue diagnostic and surgical procedures. IR detectors, visible detectors, and cameras are used for thorough tissue and blood imaging along with external infrared light sources that have appreciable penetration depth in human tissue, blood or other bodily fluids such as urine. Using a high intensity IR source at the surgical or examination site with control over the intensity, radiation pattern, and the direction of illumination helps with the most critical surgical procedures inside the vein, heart and other body organs.

[0074] Scanning or other directing mechanical elements could also be used to adjust the direction of illumination and control of the solid state light sources (laser diodes, and LEDs) used in conjunction with variety of surgical instruments inside the body, where other scanning or non scanning image capture elements detect the light. Additionally, since power is provided to the solid state light source at the distal end of the probe or scope, resistive heat from part of the electrical signal can also be used to reduce condensation at the probe or scope window.

[0075] In all embodiments described herein power and control signals are provided to the devices through the supporting structures, and when necessary the substrate material where the devices are mounted such as ceramics or Silicon substrates are made to have intimate contact with the body of the device, where heat generated

from the operating device can be conducted out of the body. In addition micro-channels to pass cooling fluid can be constructed in the body of the device to further assist the cooling function.

[0076] By placing the illumination light sources at close proximity of the object inside the body in diagnostic or surgical procedures, the losses in conjunction with the transmission of light from the external source to the surgical site is eliminated. Thus, light sources that have equal efficiency in converting electrical power to useful light, can be operated in much lower input power, eliminating the need for sophisticated power and heat management. Power and control signals transmitting through appropriate wires and flex circuitry, can be easily routed along the tool or endoscope body to the light source.

[0077] Miniature, optical components such as lenses, mirrors, beam splitters, polarizers, waveplates, etc. can also be used in conjunction with solid state light sources (laser diodes and LEDs), to further manipulate the illumination characteristics of the light. Lenses for example, can be used to direct the light to larger or smaller areas of the scene, or focusing the beam to a small area on the object depending on the application.

[0078] Polarization characteristics of the solid state laser or polarized LED light output can also be used in special detection schemes, where depth perception or other biological imaging characteristics that depend on the polarization of the light can be better perceived, similar to polarized microscopy.

[0079] The present invention may be embodied in other specific forms without departing from the disclosure of claim 1. The described embodiments are to be considered in all respects only as illustrative and not restrictive. The scope of the invention is, therefore, indicated by the appended claims rather than by the foregoing description. All changes which come within the meaning and range of equivalency of the claims are to be embraced within their scope.

Claims

1. A device for insertion into a body cavity, the device comprising:

- a cannula having a proximal end and a distal end (111), the distal end (111) being configured to be at least partially inserted into the body cavity;
- solid state light sources that are deployably disposed in relation to the distal end (111) of the cannula;
- a power source electrically coupled to the solid state light sources;

characterized in

- that the solid state light sources are configured

as white or color LEDs (382) which populate a flexible membrane (381); and

- the flexible membrane (381) having a spring at its peripheral section of the membrane (381), the membrane (381) being deployably disposed in relation to the distal end (111) of the cannula such that in an insertion position, the membrane (381) is in a tubular configuration (381a), and in the deployed position, the membrane (381) is in a substantially flat configuration (381b).

2. The device of claim 1, wherein the flexible membrane (381) is further collapsible after deploying the flexible membrane (381) in order to withdraw the cannula and the flexible membrane (381) from the body cavity.

3. The device of claim 1 or 2, further comprising a solid state light detecting device, in particular a CCD image camera or a CCD or CMOS camera chip, that are time synchronized with the solid state light sources of various wavelength, to capture various color component images in a time synchronized fashion.

4. The device of claim 1, wherein the cannula further comprises channels for conveying a cooling fluid to transfer heat from the solid state light source to the proximal end of the cannula.

Patentansprüche

1. Vorrichtung zum Einführen in eine Körperhöhle, wobei die Vorrichtung Folgendes umfasst:

- eine Kanüle mit einem proximalen Ende und einem distalen Ende (111), wobei das distale Ende (111) dafür ausgelegt ist, wenigstens teilweise in die Körperhöhle eingeführt zu werden;
- Festphasen-Lichtquellen, die in Bezug auf das distale Ende (111) der Kanüle entfaltbar angeordnet sind;
- eine Stromquelle, die mit den Festphasen-Lichtquellen elektrisch gekoppelt ist;

dadurch gekennzeichnet, dass

- die Festphasen-Lichtquellen als weiße oder farbige Leuchtdioden (382) ausgeführt sind, mit denen eine biegsame Membran (381) bestückt ist; und
- die biegsame Membran (381) eine Feder am Umfangsabschnitt der Membran (381) aufweist, wobei die Membran (381) in Bezug auf das distale Ende (111) der Kanüle entfaltbar angeordnet ist, so dass sich die Membran (381) in einer Einfügeposition in einer rohrförmigen Konfiguration (381a) befindet und sich die Membran

(381) in der entfalteten Position in einer im Wesentlichen flachen Konfiguration (381b) befindet.

2. Vorrichtung nach Anspruch 1, wobei die biegsame Membran (381) nach dem Entfalten der biegsamen Membran (381) wieder zusammengefaltet werden kann, um die Kanüle und die biegsame Membran (381) aus der Körperhöhle zu entfernen.
3. Vorrichtung nach Anspruch 1 oder 2, ferner umfassend eine Festphasen-Lichtdetektionsvorrichtung, insbesondere eine CCD-Kamera oder einen CCD- oder CMOS-Kamerachip, die mit den Festphasen-Lichtquellen mit verschiedenen Wellenlängen zeitlich synchronisiert sind, um auf zeitlich synchronisierte Weise Bilder mit verschiedenen Farbkomponenten aufzunehmen.
4. Vorrichtung nach Anspruch 1, wobei die Kanüle ferner Kanäle zur Beförderung eines Kühlfluids umfasst, um Wärme von der Festphasen-Lichtquelle zum proximalen Ende der Kanüle zu übertragen.

flexible (381) étant de plus escamotable de manière à retirer la canule et la membrane flexible (381) de la cavité corporelle.

- 5 3. Dispositif selon la revendication 1 ou 2 comprenant de plus un dispositif de détection de lumière à l'état solide, en particulier une caméra CCD ou une puce de caméra CCD ou CMOS, qui est synchronisé dans le temps avec les sources lumineuses à l'état solide de différentes longueurs d'onde pour saisir des images de différents composants de couleur de manière synchronisée dans le temps.
- 10
- 15 4. Dispositif selon la revendication 1, la canule comprenant de plus des canaux pour transporter un fluide de refroidissement pour transférer la chaleur de la source de lumière à l'état solide à l'extrémité proximale de la canule.

25

Revendications

1. Dispositif pour insertion dans une cavité corporelle, le dispositif comprenant :

30

- une canule qui a une extrémité proximale et une extrémité distale (111), l'extrémité distale (111) étant configurée pour être au moins partiellement insérée dans la cavité corporelle ;
- des sources lumineuses à l'état solide qui sont disposées en pouvant être déployées en relation avec l'extrémité distale (111) de la canule ;
- une source de courant couplée électriquement aux sources lumineuses à l'état solide,

40

caractérisé en ce

- **que** les sources lumineuses à l'état solide sont configurées comme des LED blanches ou de couleur (382) qui peuplent une membrane flexible (381) et
- la membrane flexible (381) ayant un ressort sur sa section périphérique de la membrane (381), la membrane (381) étant placée de manière à pouvoir être déployée en relation avec l'extrémité distale (111) de la canule de telle manière que, dans une position d'insertion, la membrane (381) est de configuration tubulaire (381a) et, dans la position déployée, la membrane (381) est de configuration substantiellement plate (381 b).

45

50

55

2. Dispositif selon la revendication 1, la membrane

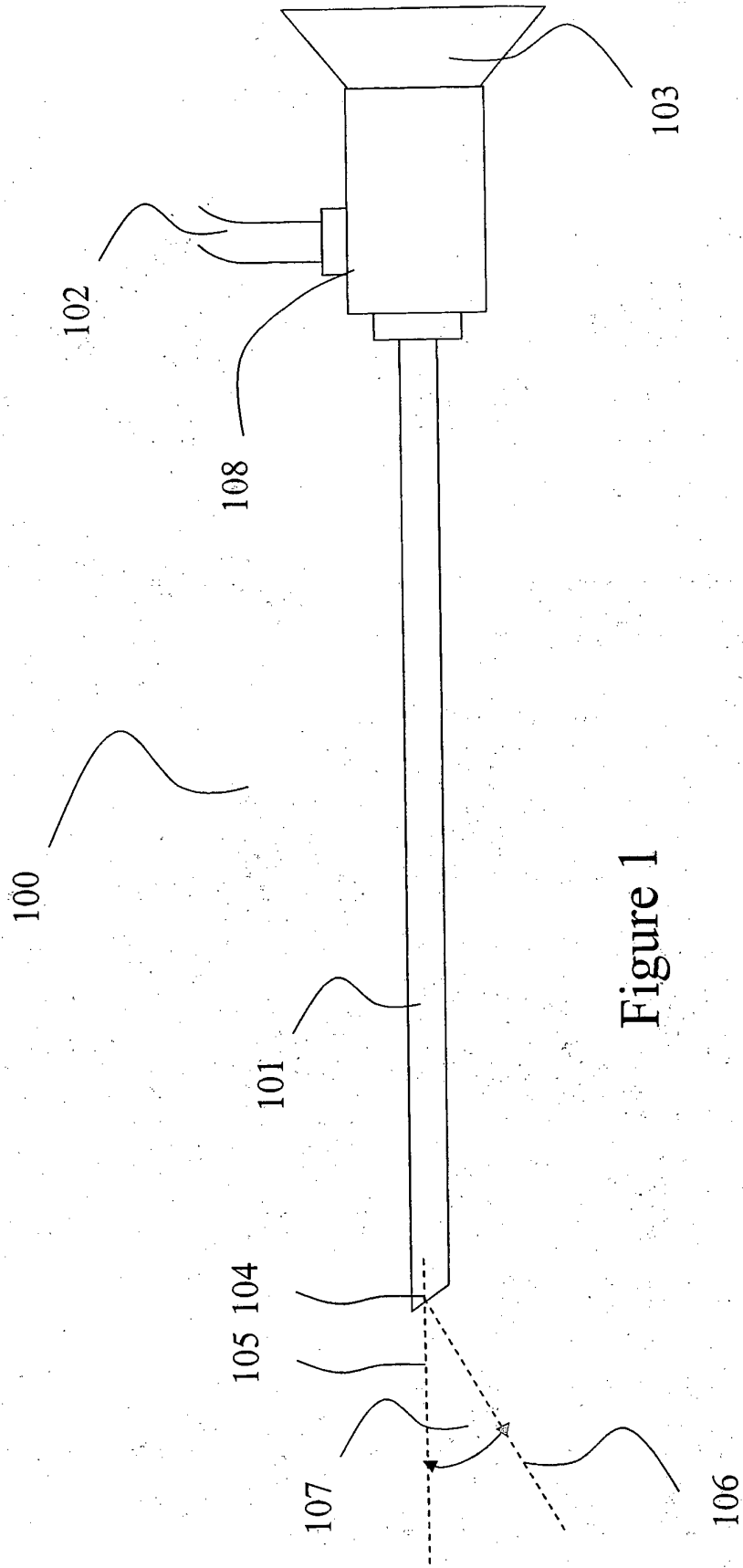

Figure 1

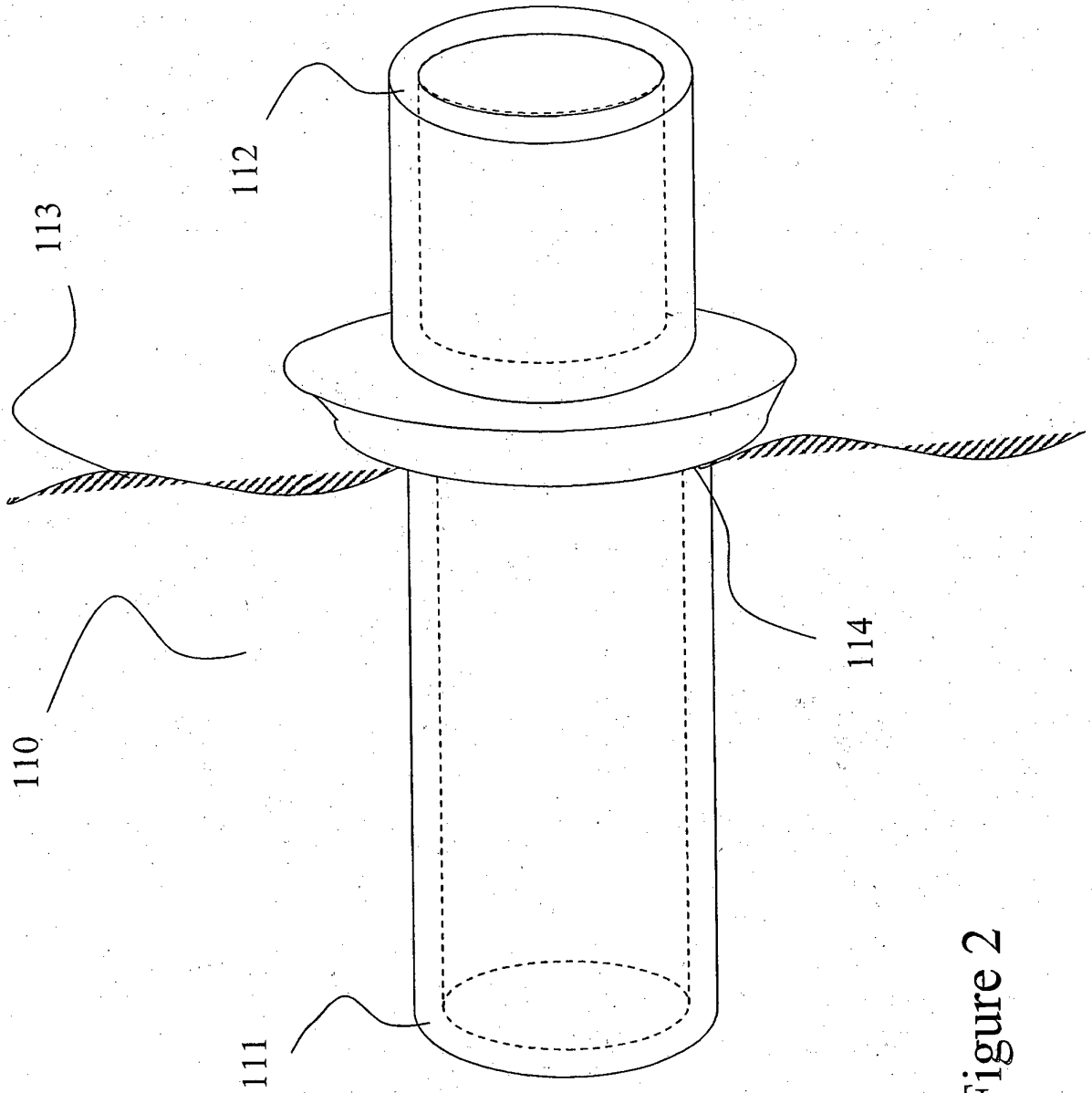

Figure 2

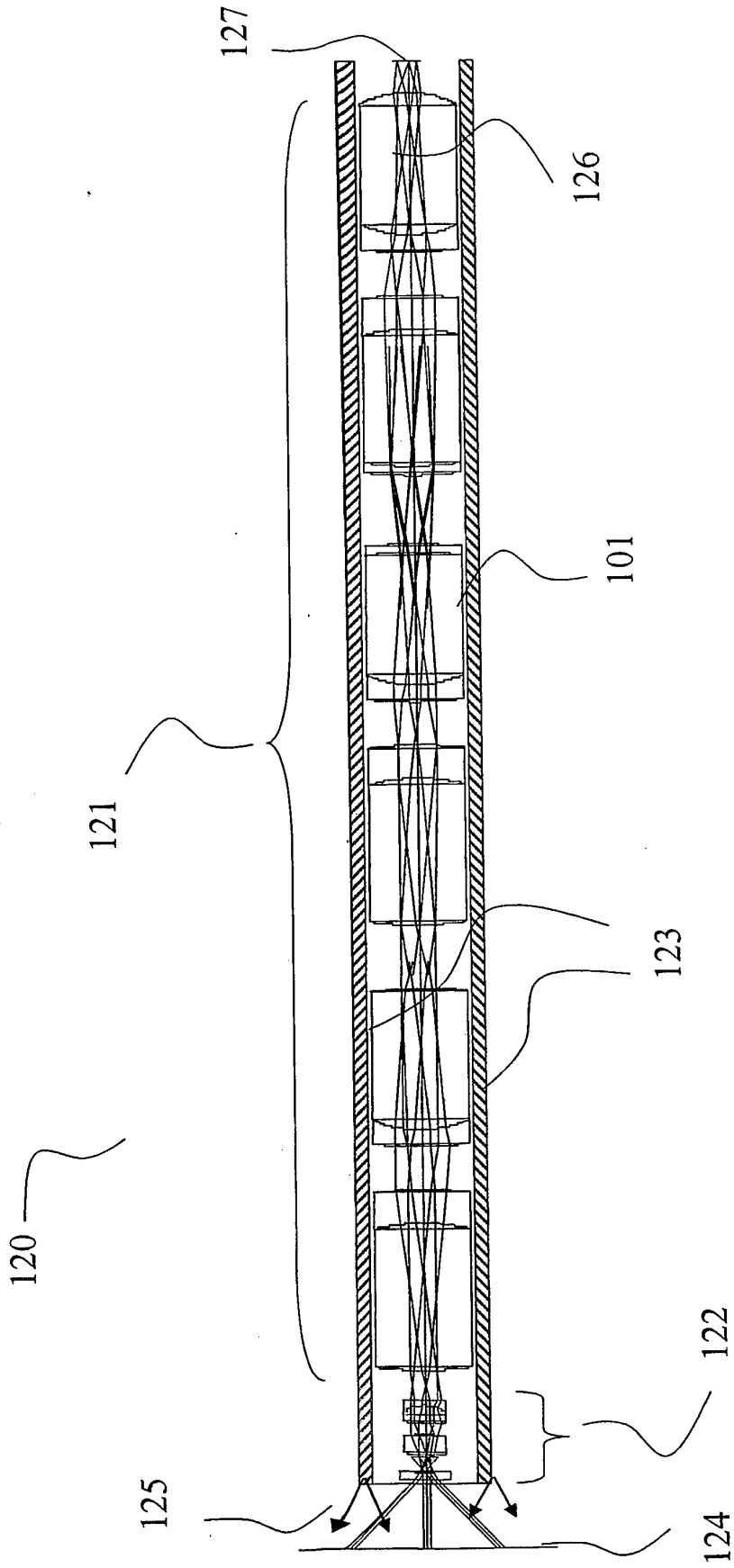

Figure 3

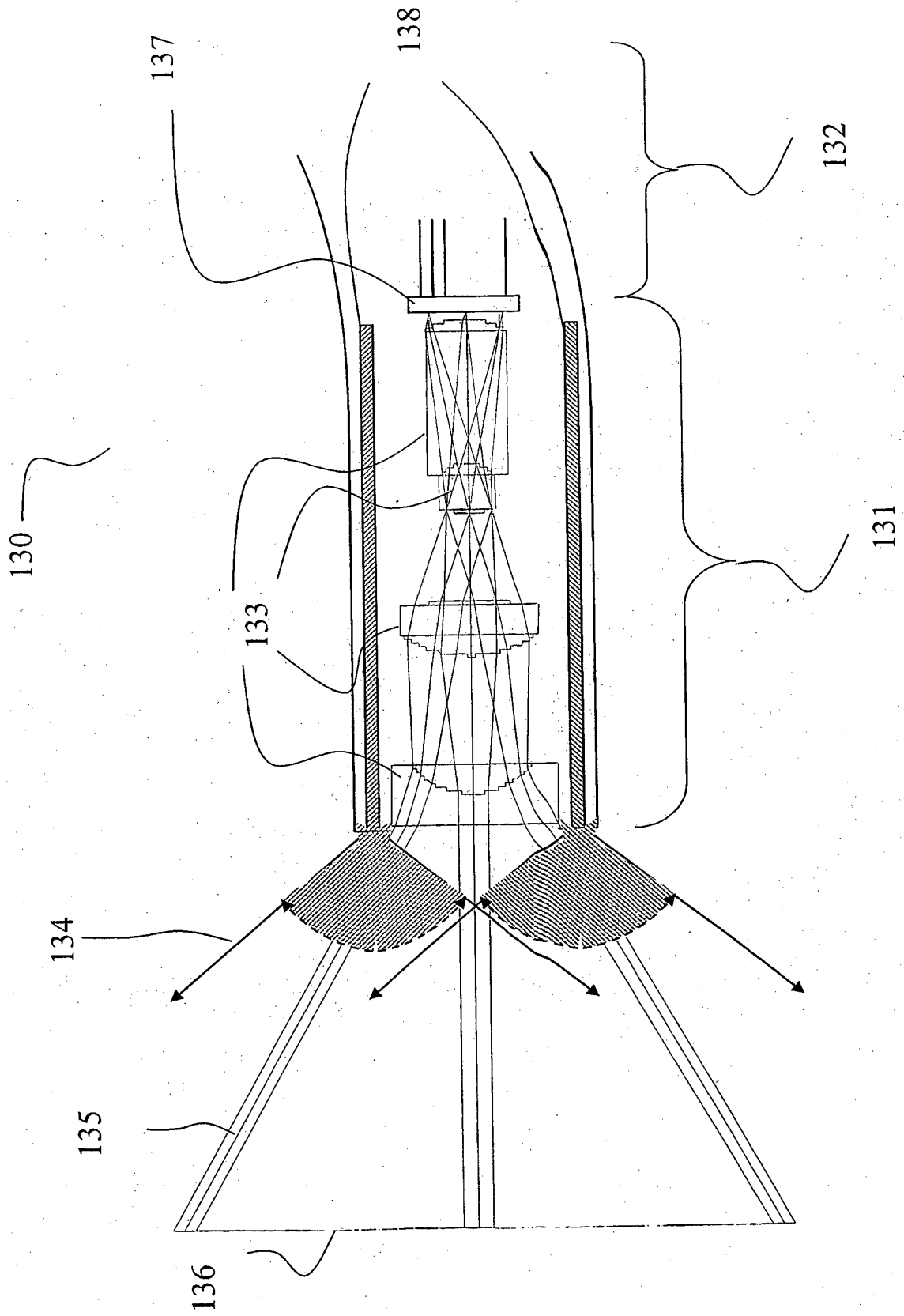

Figure 4

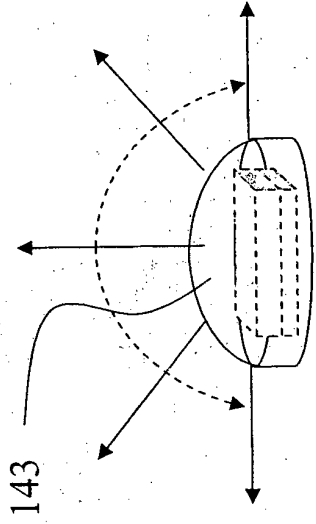

Figure 5b

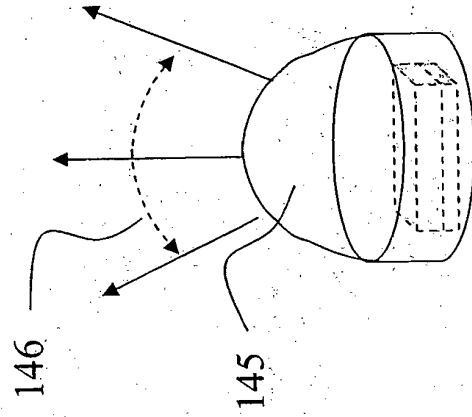

Figure 5d

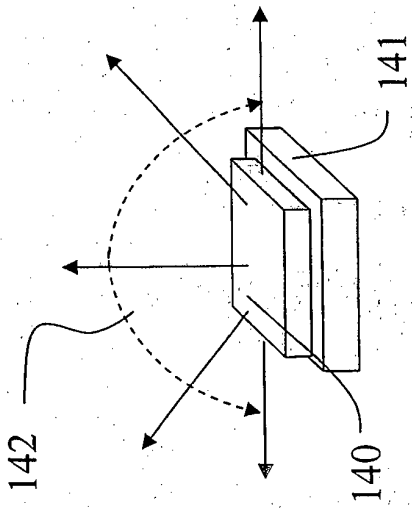

Figure 5a

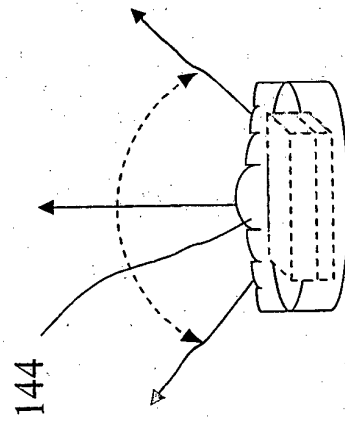

Figure 5c

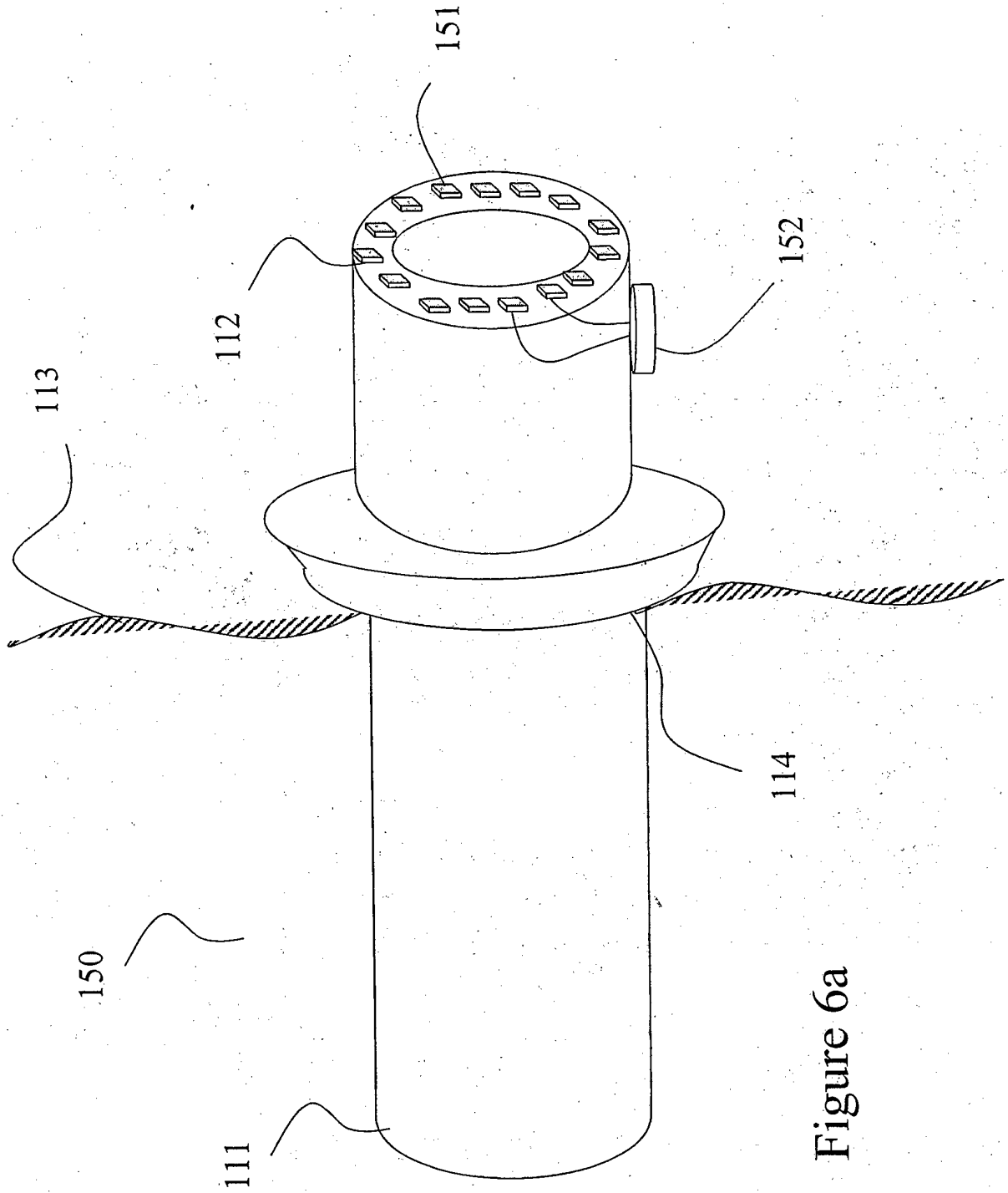

Figure 6a

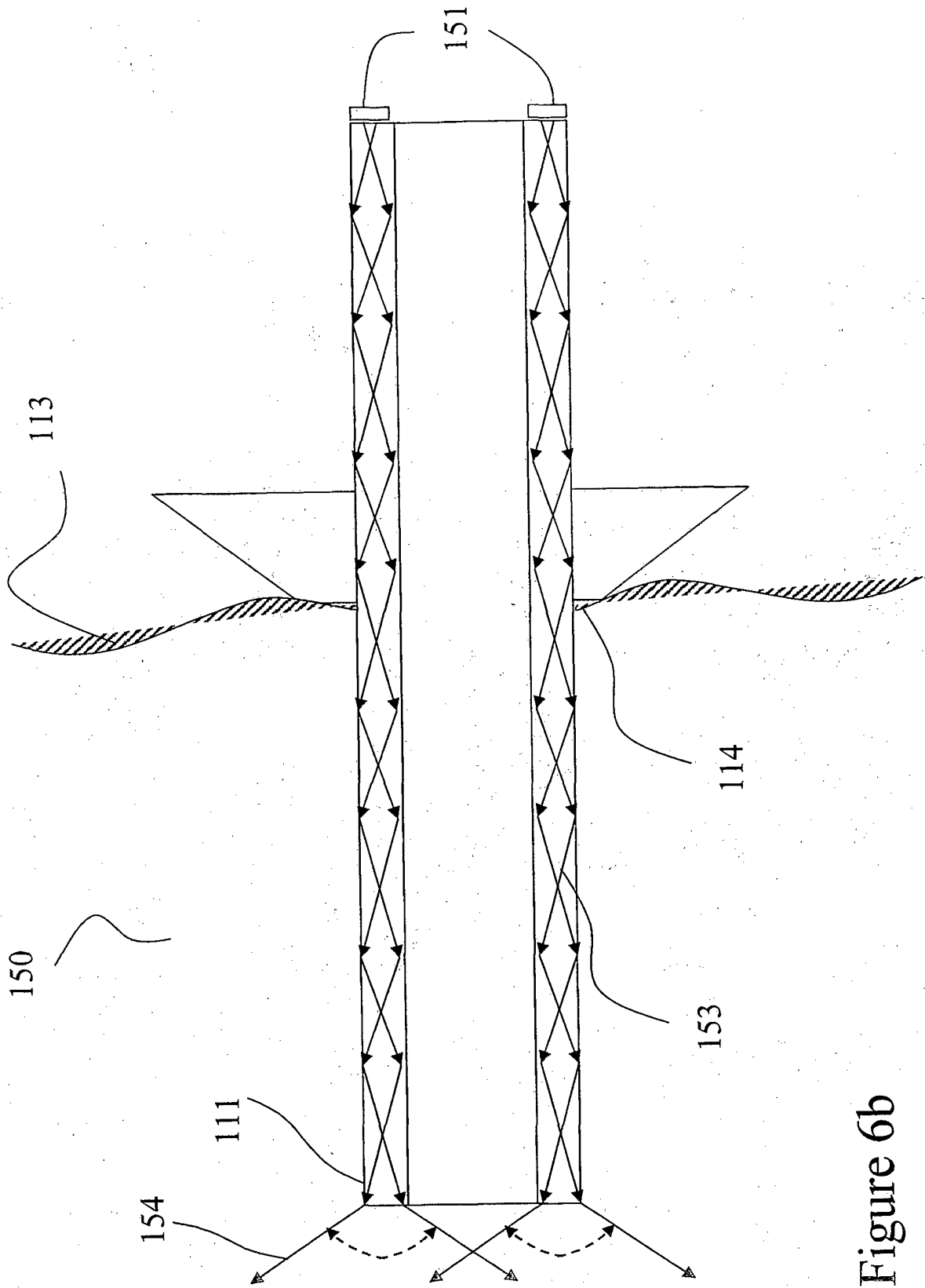

Figure 6b

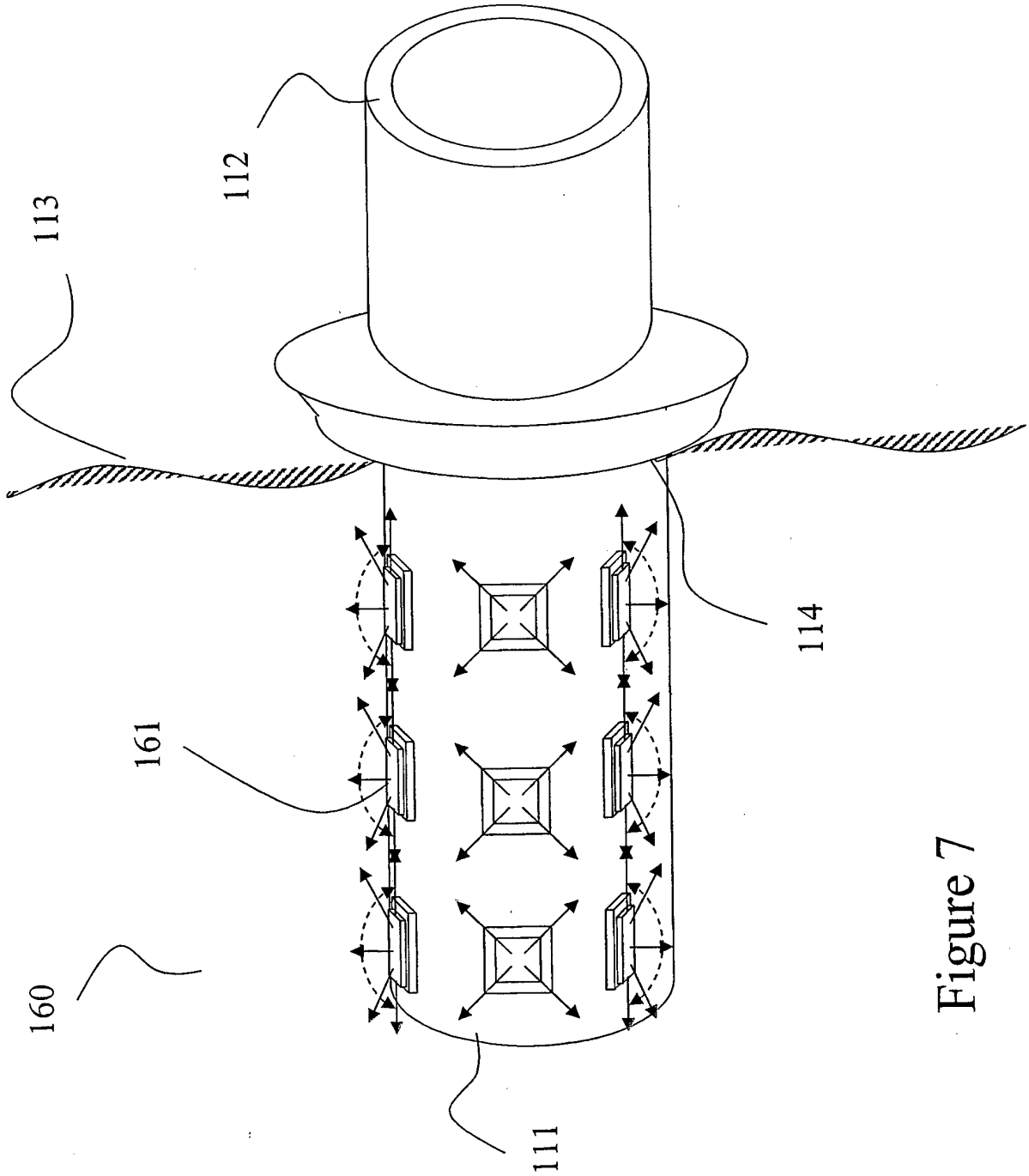

Figure 7

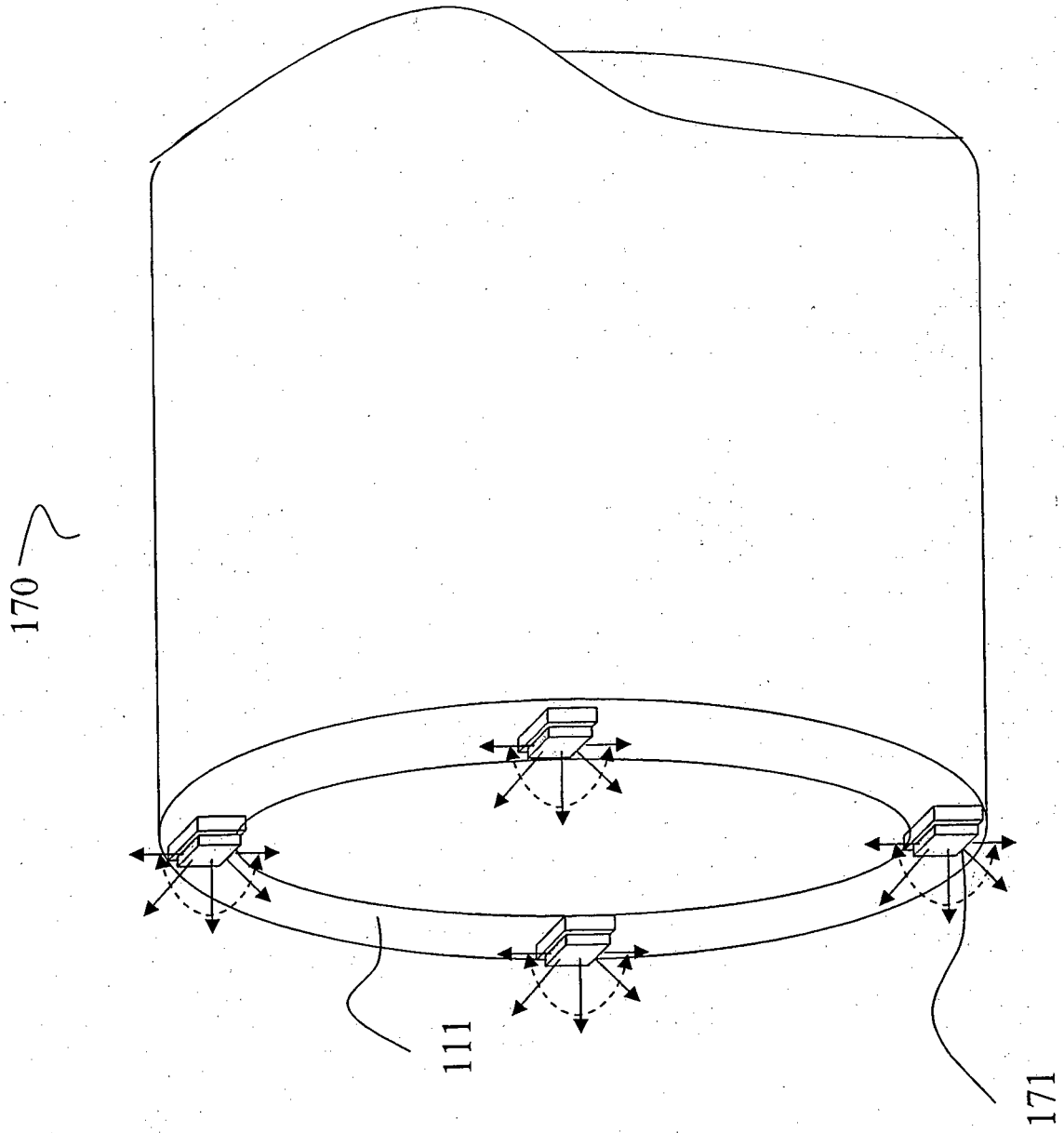

Figure 8

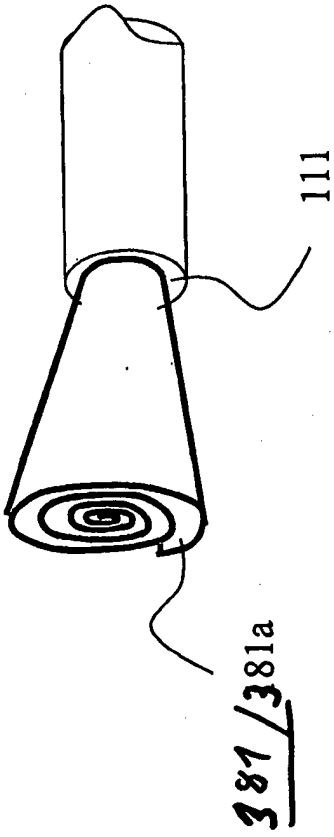

Figure 12a

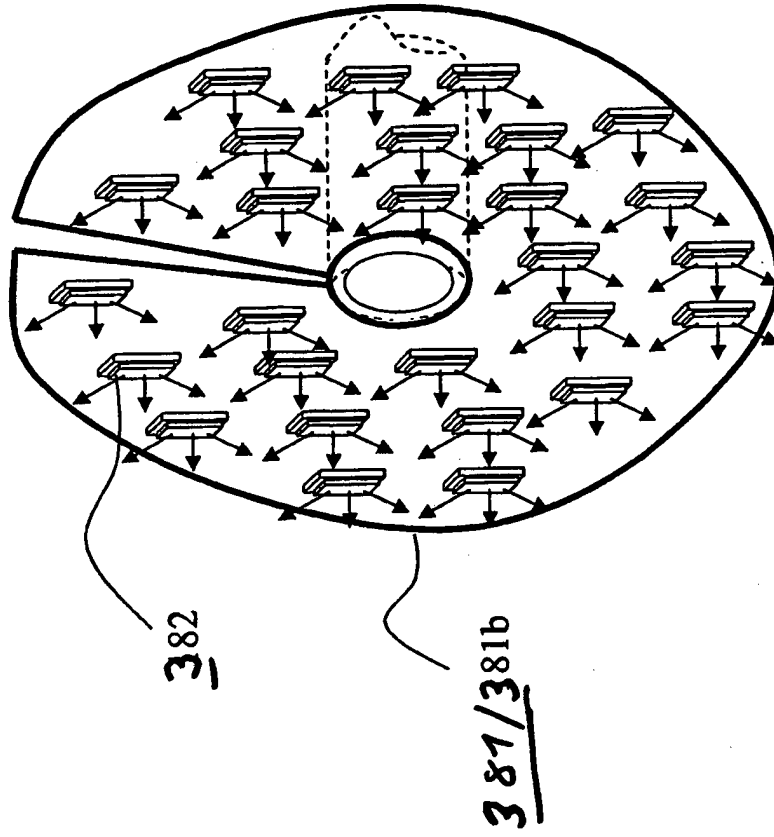

Figure 12b

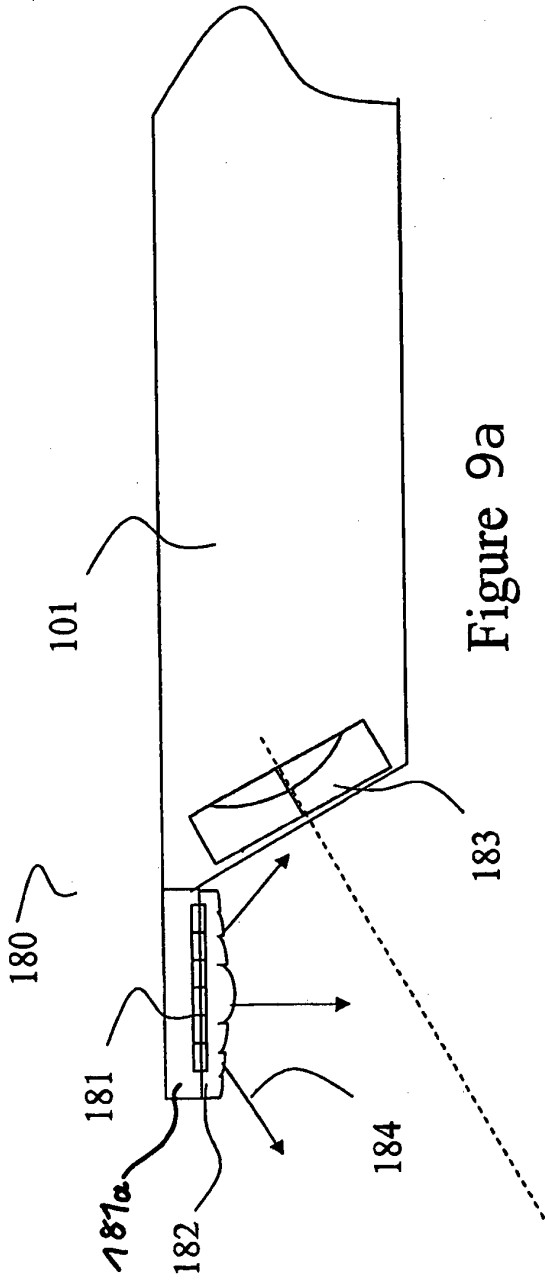

Figure 9a

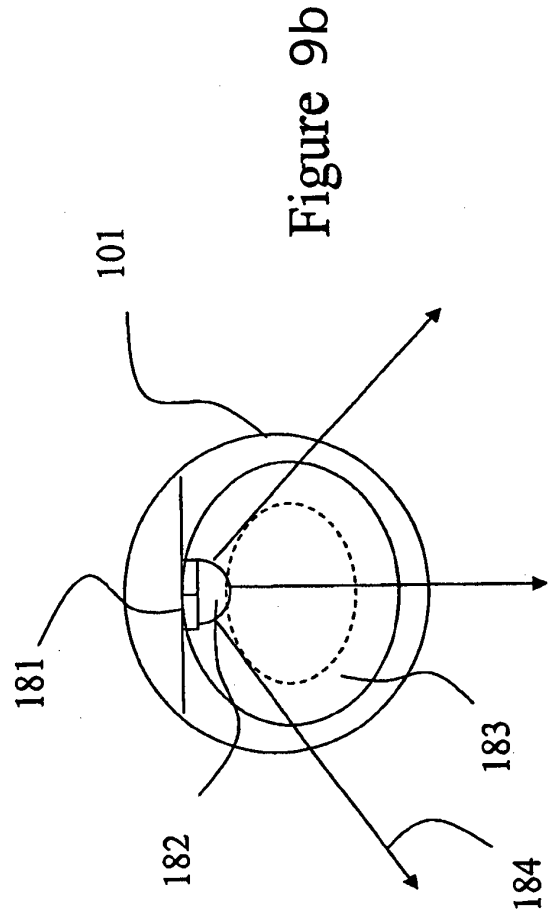

Figure 9b

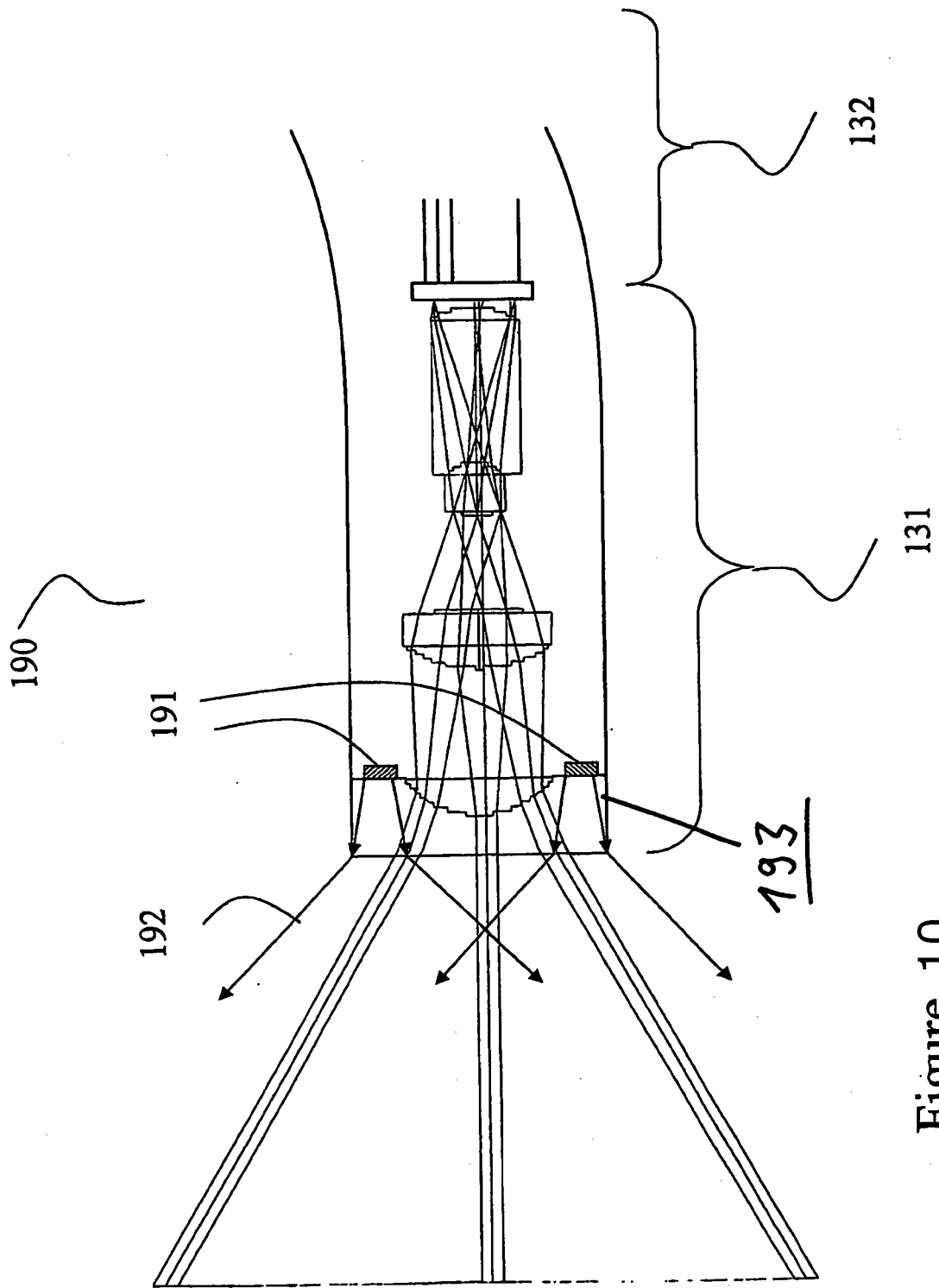

Figure 10

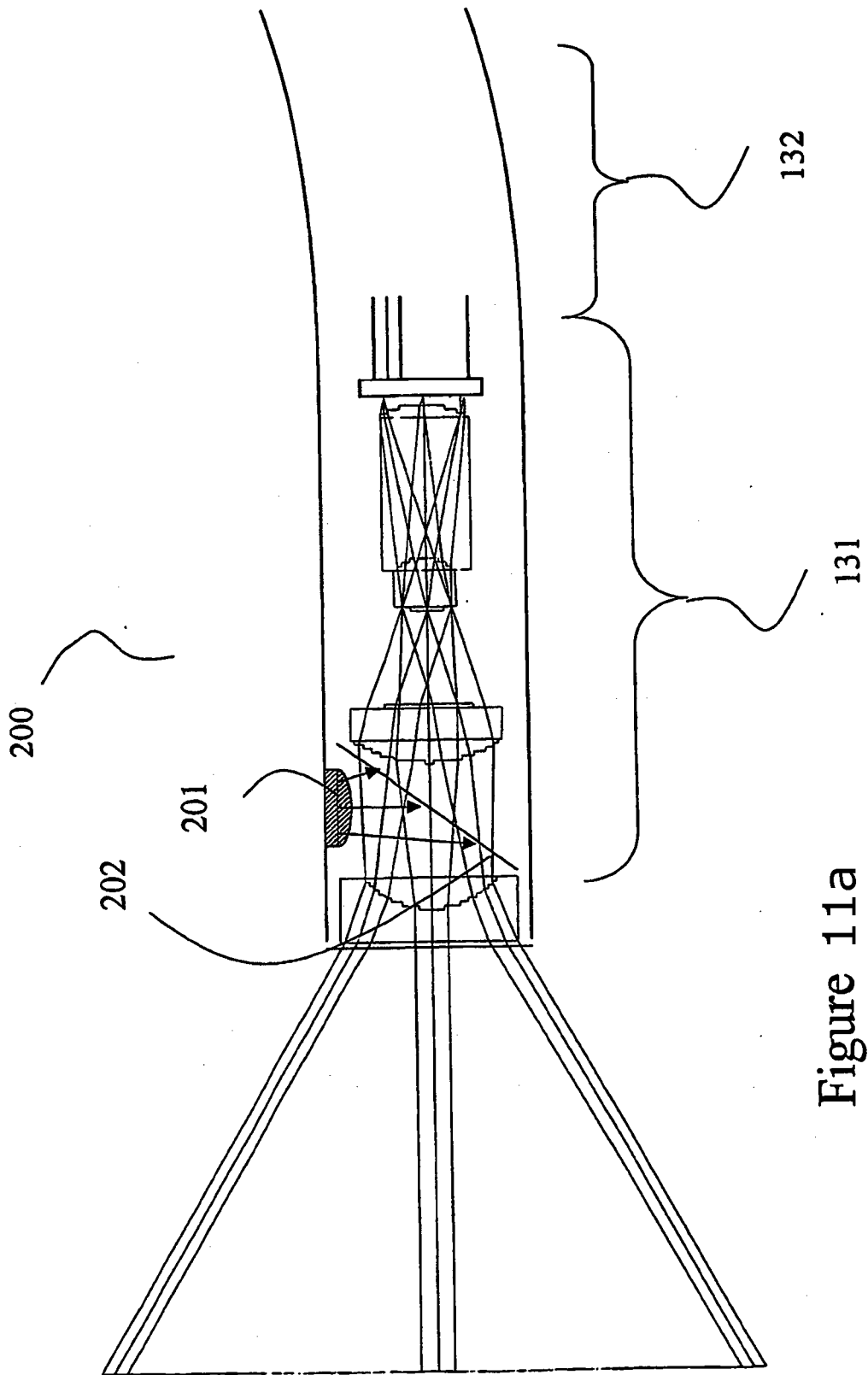

Figure 11a

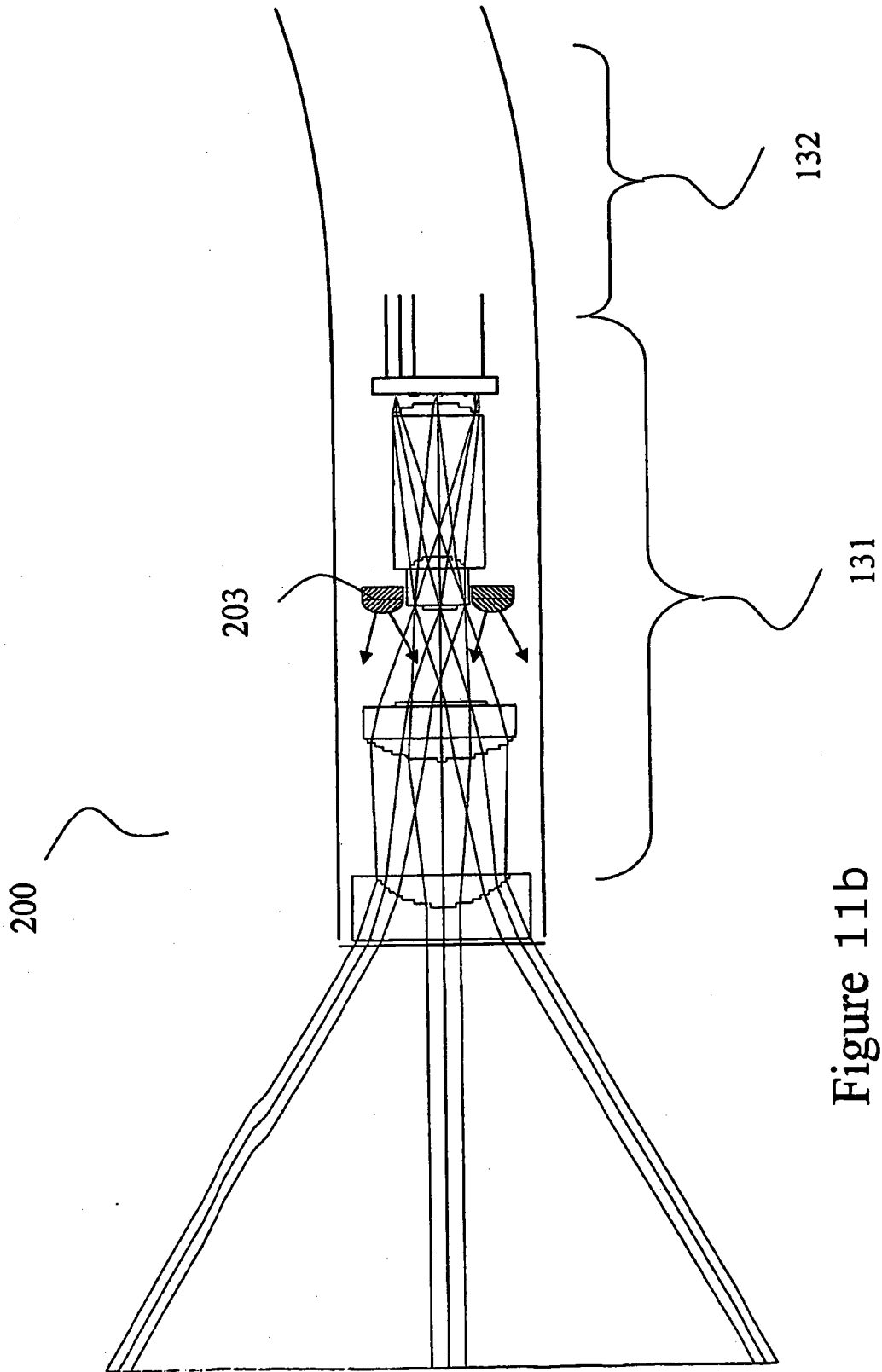

Figure 11b

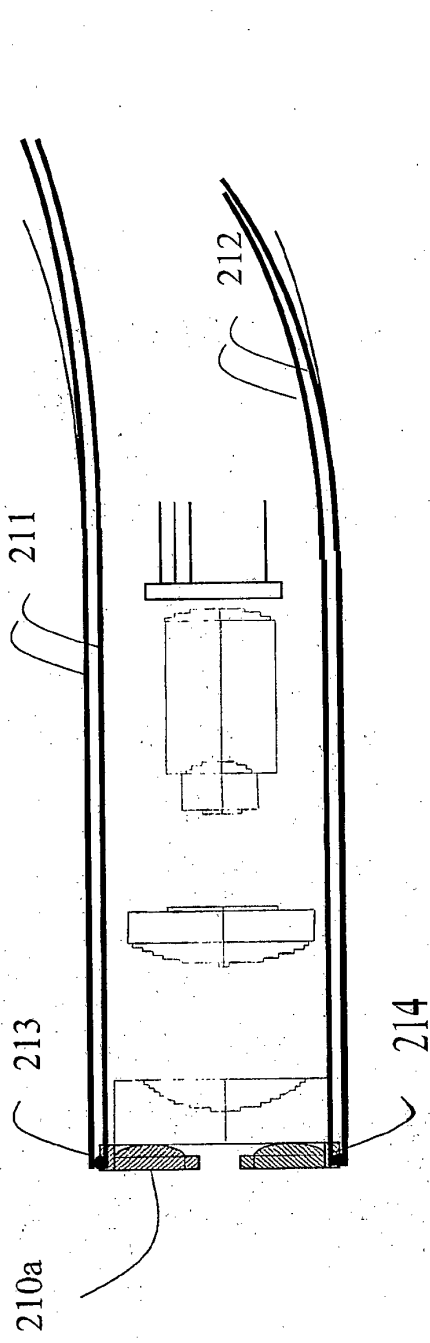

Figure 13a

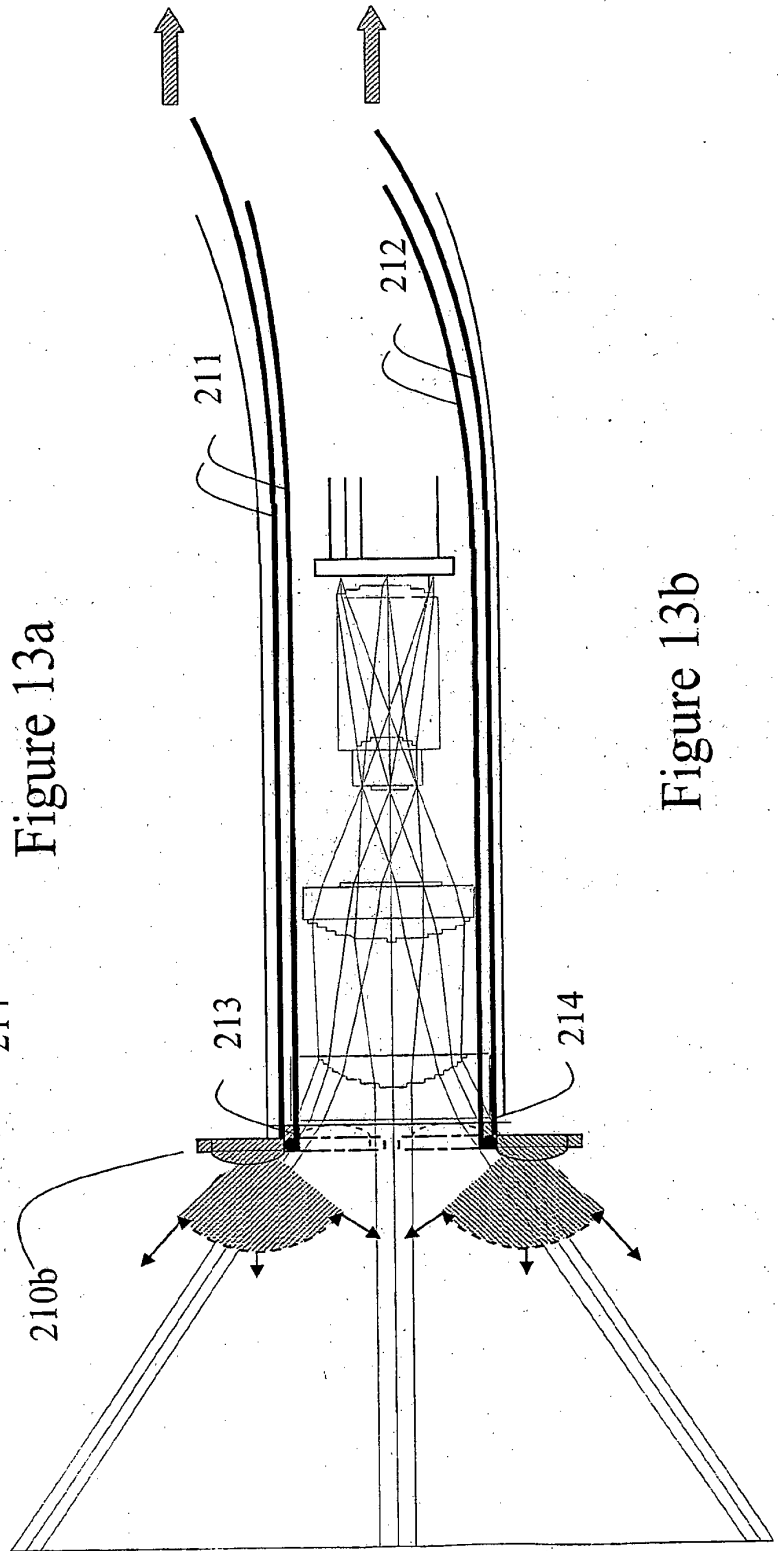

Figure 13b

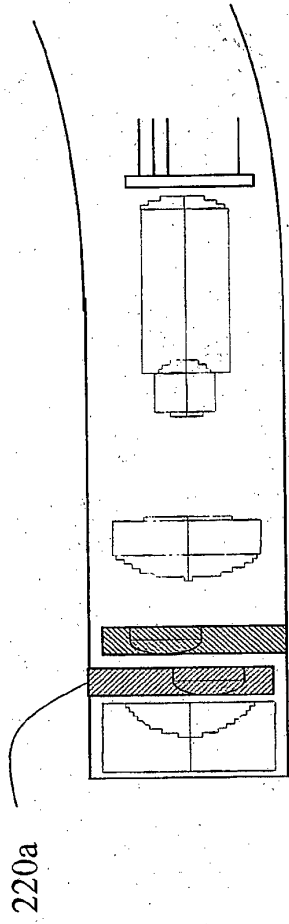

Figure 14a

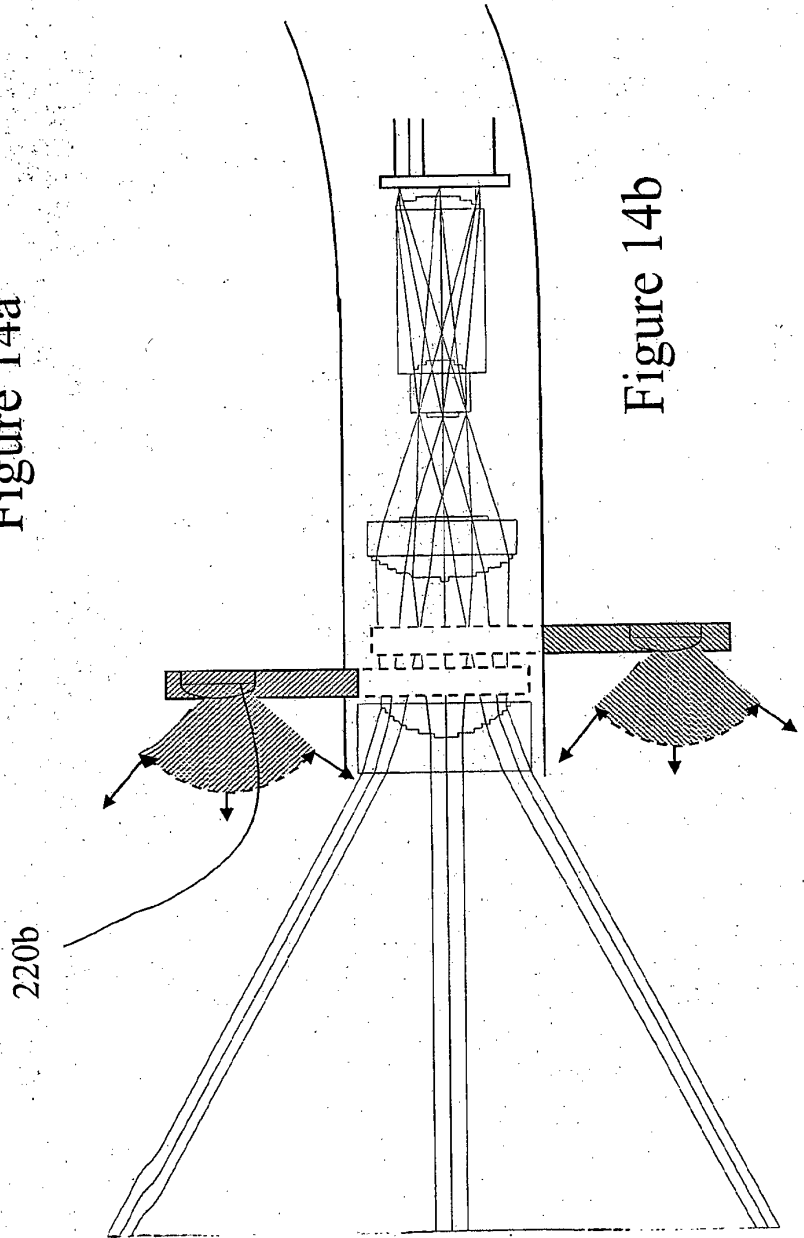

Figure 14b

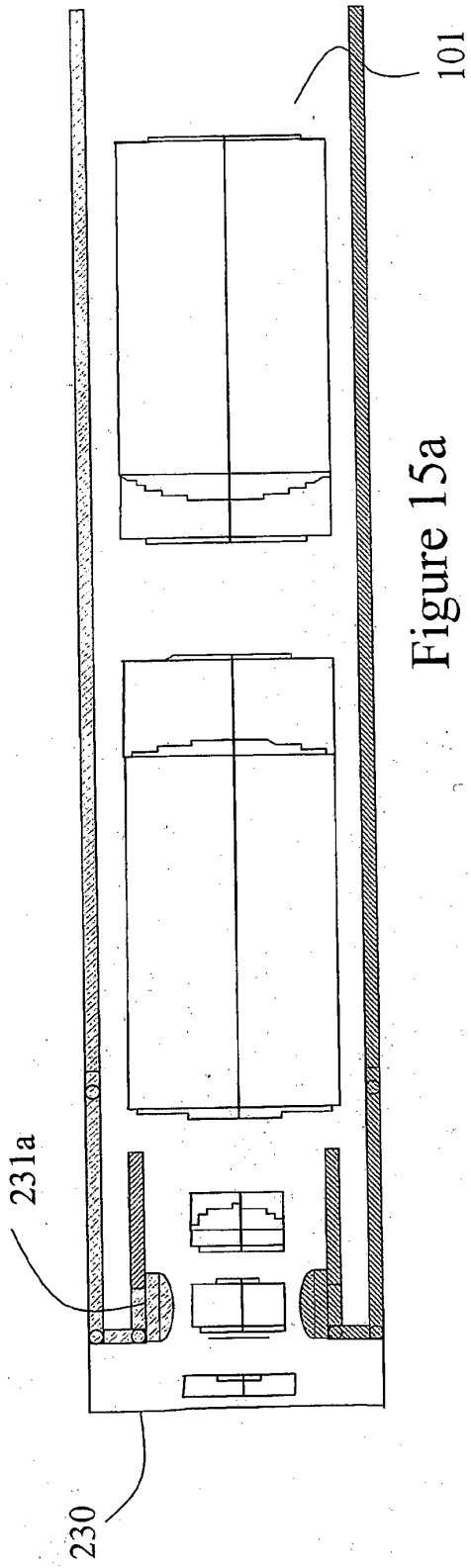

Figure 15a

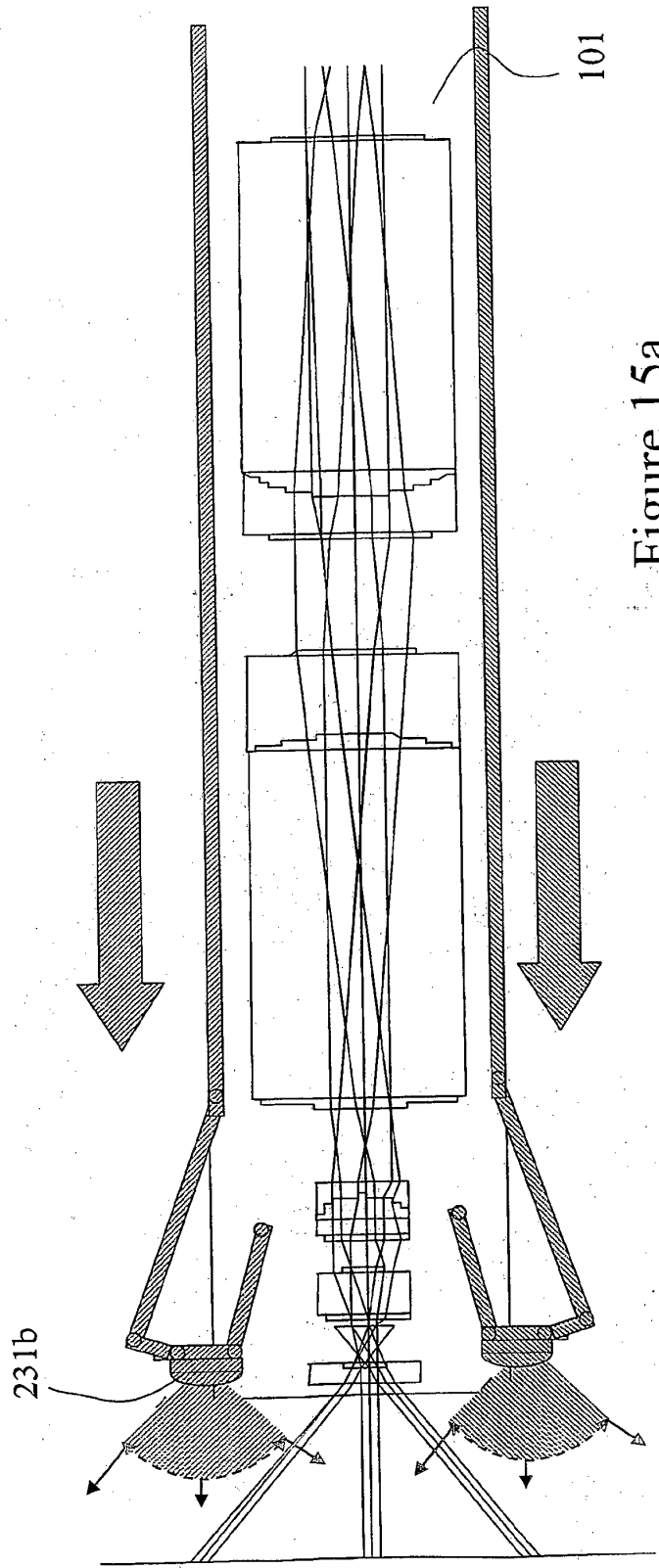

Figure 15a

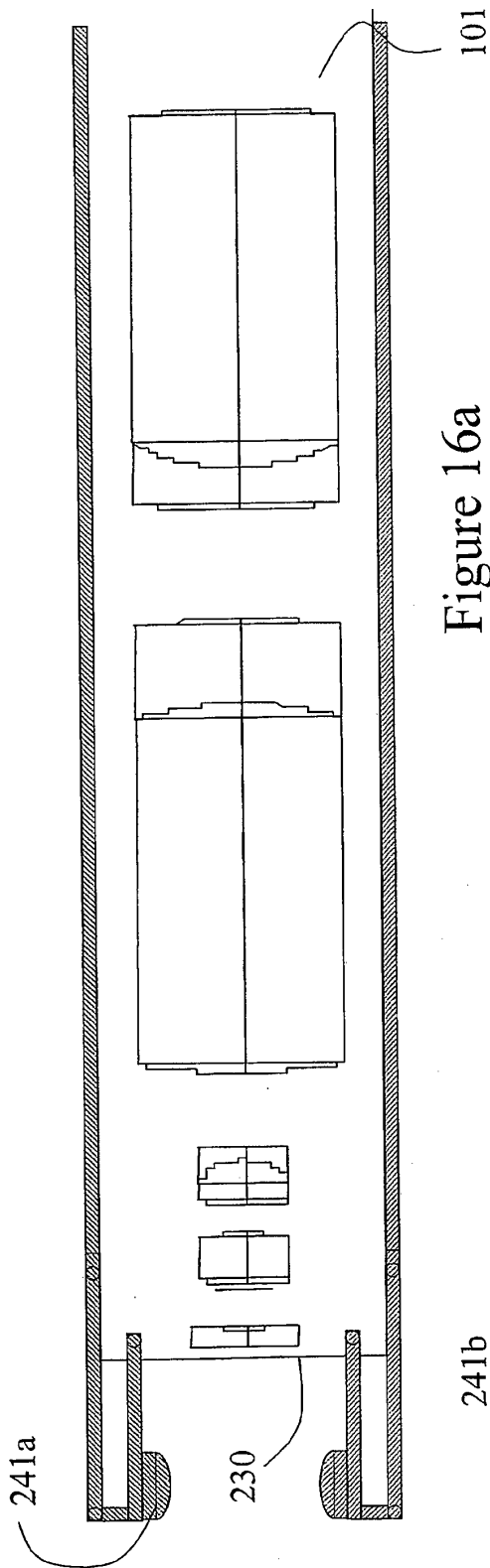

Figure 16a

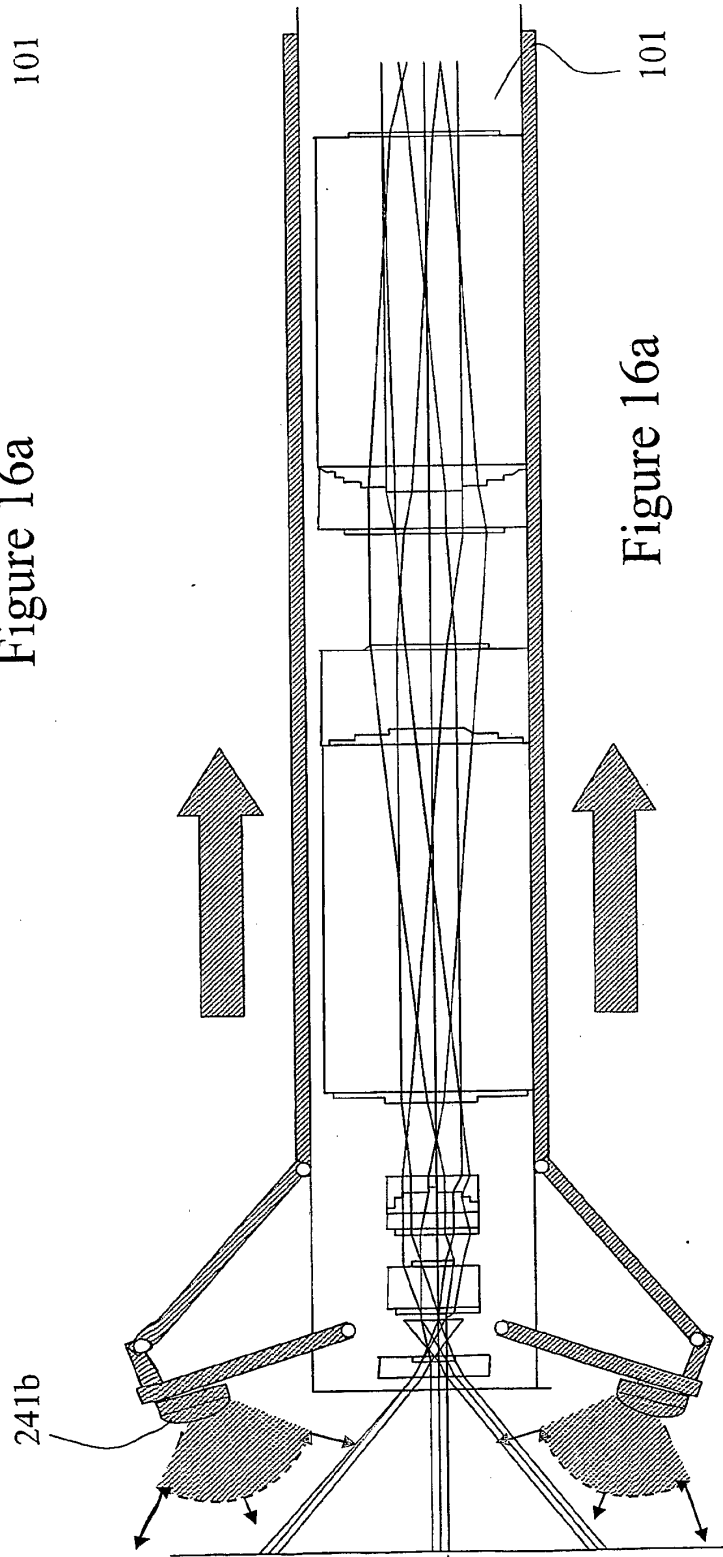
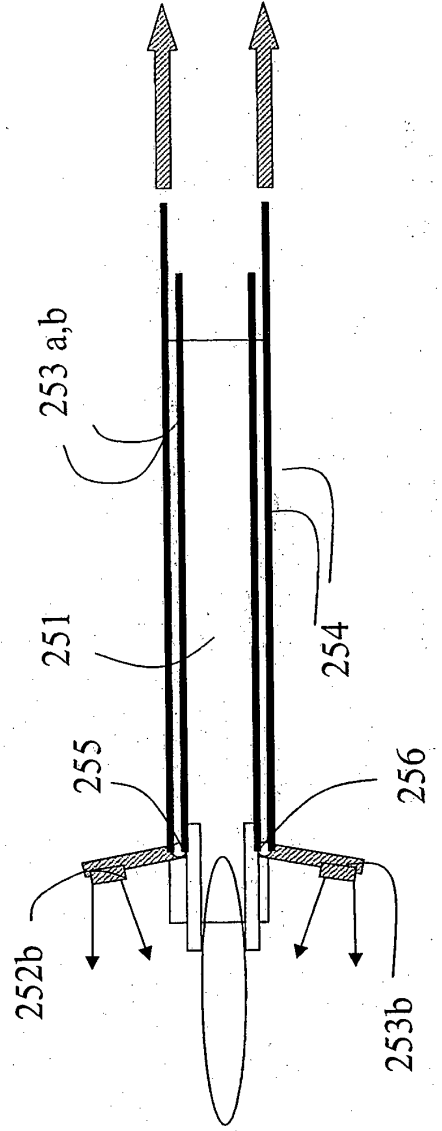
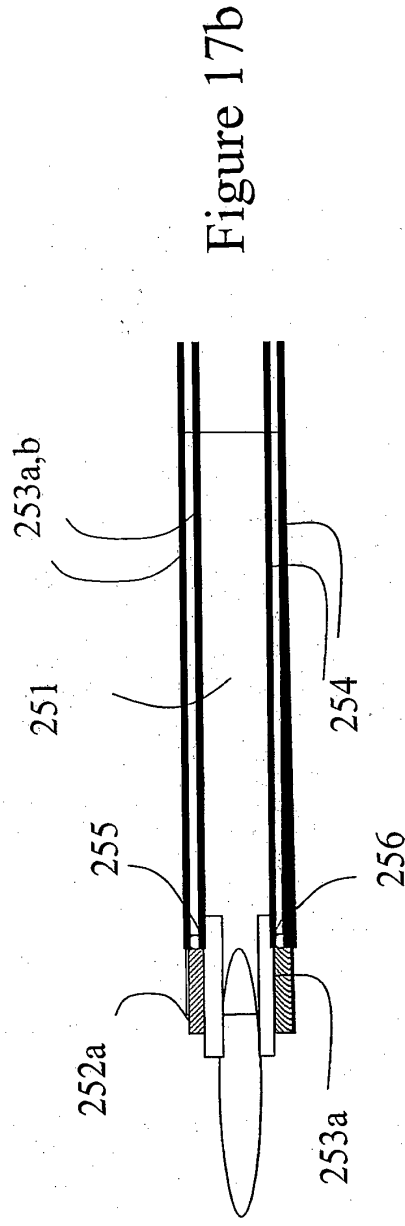
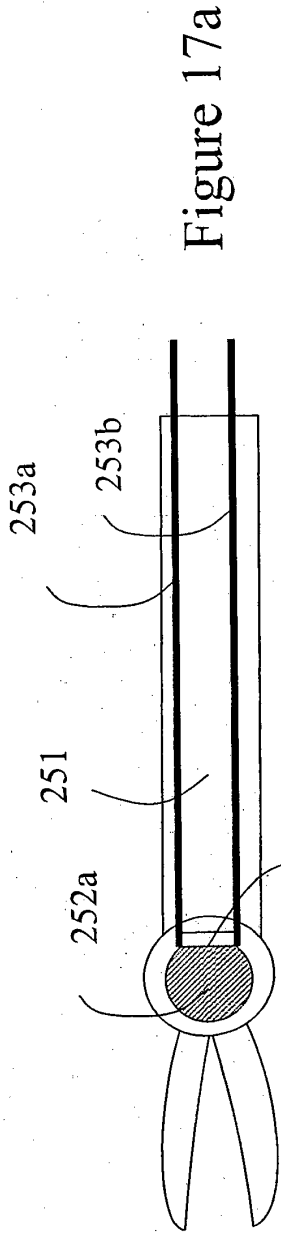

Figure 16a



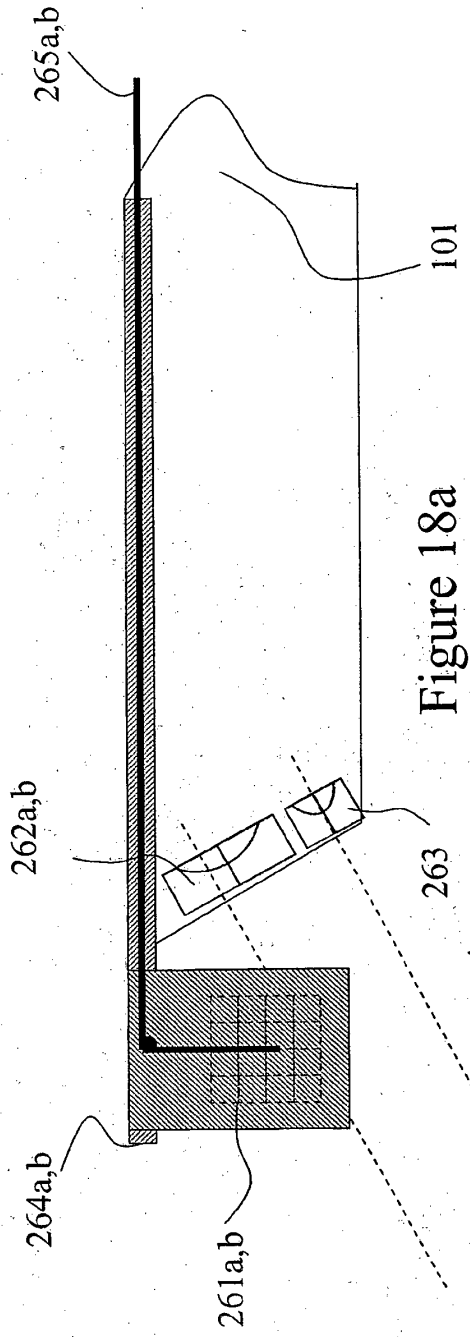

Figure 18a

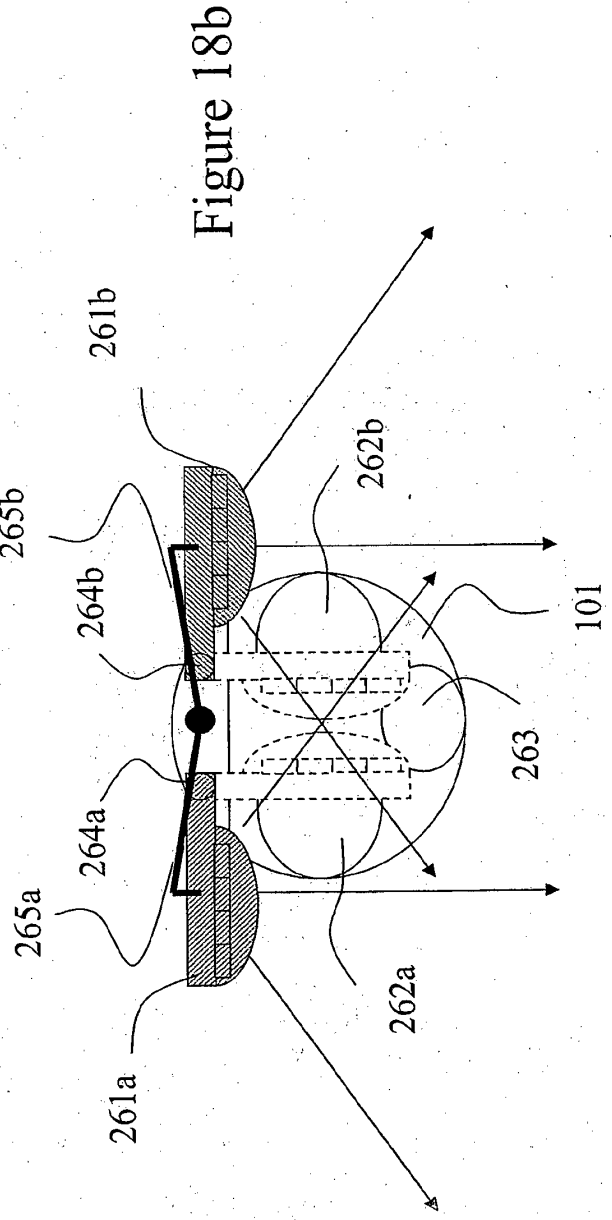

Figure 18b

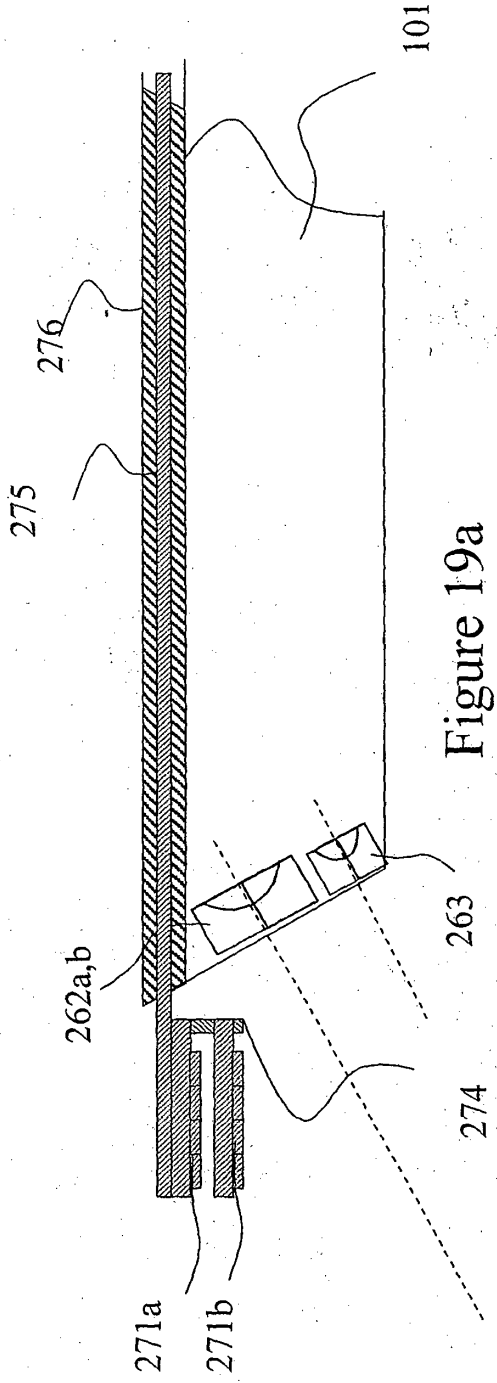

Figure 19a

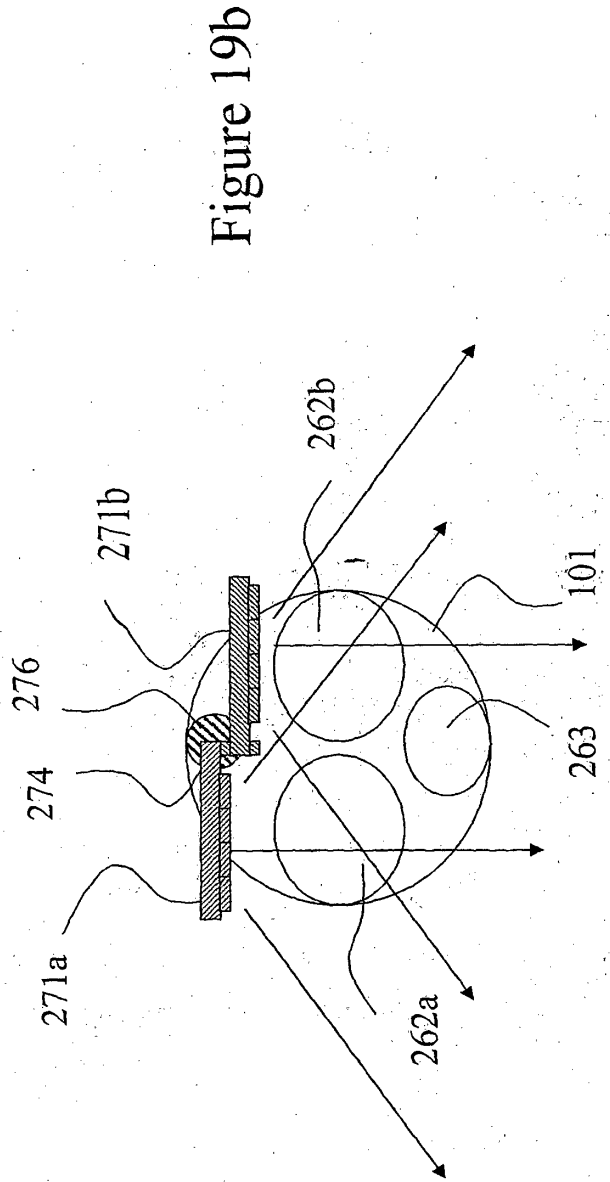

Figure 19b

REFERENCES CITED IN THE DESCRIPTION

This list of references cited by the applicant is for the reader's convenience only. It does not form part of the European patent document. Even though great care has been taken in compiling the references, errors or omissions cannot be excluded and the EPO disclaims all liability in this regard.

Patent documents cited in the description

- US 2003120130 A1 [0028]
- WO 0050809 A1 [0029]

专利名称(译)	用于内窥镜检查的固态照明		
公开(公告)号	EP1804640A4	公开(公告)日	2010-12-22
申请号	EP2005802624	申请日	2005-09-26
[标]申请(专利权)人(译)	FARR MINA		
申请(专利权)人(译)	FARR , MINA		
当前申请(专利权)人(译)	FARR , MINA		
[标]发明人	FARR MINA		
发明人	FARR, MINA		
IPC分类号	A61B1/06 A61B1/005 A61B1/12 A61B17/00		
CPC分类号	A61B1/0676 A61B1/00096 A61B1/00179 A61B1/0051 A61B1/04 A61B1/042 A61B1/0607 A61B1/0615 A61B1/0623 A61B1/063 A61B1/0653 A61B1/0684 A61B1/07 A61B1/126 A61B2090/306 A61B2090/309		
优先权	11/233684 2005-09-23 US 60/612889 2004-09-24 US		
其他公开文献	EP1804640B1 EP1804640A2		
外部链接	Espacenet		

摘要(译)

提供了用于为内窥镜检查或孔镜检查提供固态照明的各种实施例。通常，各种医疗或工业设备可包括位于其上的一个或多个固态或其他紧凑型电光照明设备。固态或紧凑型电光照明装置可包括但不限于发光二极管 (LED)，激光二极管 (LD) 或其他红外 (IR) 或紫外线 (UV) 源。各种波长的固态源可以用于照亮物体以用于成像或检测目的或其他调节目。固态照明装置可以放置在装置的外表面上，装置内部，可展开地联接到装置的远端，或者以其他方式设置在装置上。