



(51) International Patent Classification:

A61B 17/02 (2006.01) A61M 25/10 (2006.01)  
A61M 29/02 (2006.01) A61B 17/94 (2006.01)

(21) International Application Number:

PCT/US2012/020138

(22) International Filing Date:

4 January 2012 (04.01.2012)

(25) Filing Language:

English

(26) Publication Language:

English

(30) Priority Data:

61/429,648 4 January 2011 (04.01.2011) US  
61/450,682 9 March 2011 (09.03.2011) US

(71) Applicant (for all designated States except US):

**THE JOHNS HOPKINS UNIVERSITY** [US/US]; 3400 North Charles Street, Baltimore, Maryland 21218 (US).

(72) Inventor; and

(75) Inventor/Applicant (for US only):

**NGUYEN, Hien Tan** [US/US]; 100 Harborview Drive, Unit #403, Baltimore, Maryland 21230 (US).

(74) Agent: **SPECTOR, Elaine**; 100 N. Charles Street, 5th Floor, Baltimore, Maryland 21201 (US).

(81) Designated States (unless otherwise indicated, for every kind of national protection available):

AE, AG, AL, AM, AO, AT, AU, AZ, BA, BB, BG, BH, BR, BW, BY, BZ, CA, CH, CL, CN, CO, CR, CU, CZ, DE, DK, DM, DO, DZ, EC, EE, EG, ES, FI, GB, GD, GE, GH, GM, GT, HN, HR, HU, ID, IL, IN, IS, JP, KE, KG, KM, KN, KP, KR, KZ, LA, LC, LK, LR, LS, LT, LU, LY, MA, MD, ME, MG, MK, MN, MW, MX, MY, MZ, NA, NG, NI, NO, NZ, OM, PE, PG, PH, PL, PT, QA, RO, RS, RU, RW, SC, SD, SE, SG, SK, SL, SM, ST, SV, SY, TH, TJ, TM, TN, TR, TT, TZ, UA, UG, US, UZ, VC, VN, ZA, ZM, ZW.

(84) Designated States (unless otherwise indicated, for every kind of regional protection available):

ARIPO (BW, GH, GM, KE, LR, LS, MW, MZ, NA, RW, SD, SL, SZ, TZ, UG, ZM, ZW), Eurasian (AM, AZ, BY, KG, KZ, MD, RU, TJ, TM), European (AL, AT, BE, BG, CH, CY, CZ, DE, DK, EE, ES, FI, FR, GB, GR, HR, HU, IE, IS, IT, LT, LU, LV, MC, MK, MT, NL, NO, PL, PT, RO, RS, SE, SI, SK, SM, TR), OAPI (BF, BJ, CF, CG, CI, CM, GA, GN, GQ, GW, ML, MR, NE, SN, TD, TG).

[Continued on next page]

(54) Title: MINIMALLY INVASIVE LAPAROSCOPIC RETRACTOR

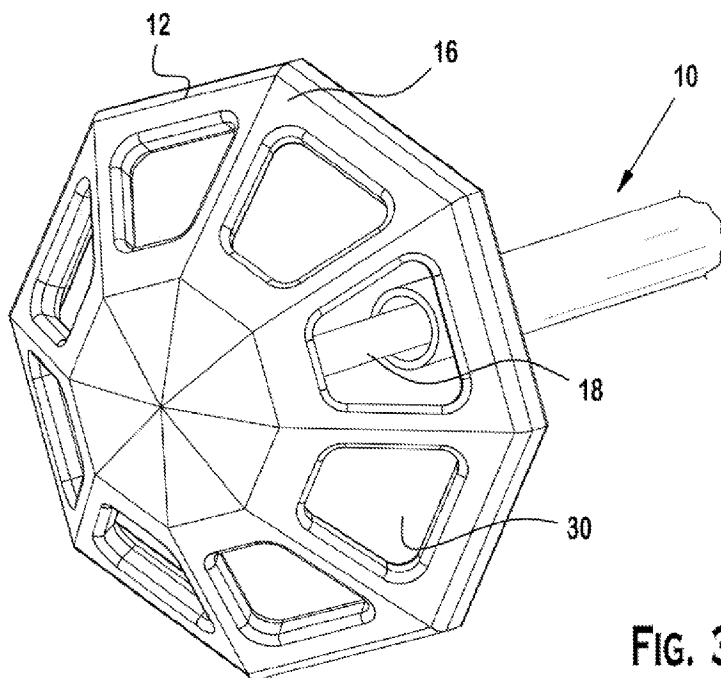

FIG. 3

(57) Abstract: An inflatable retractor for use in laparoscopic surgery of a patient's body includes an inflatable element disposed at a distal end of a retractor shaft. The retractor shaft includes a port for receiving insufflating fluid. The inflatable element is designed so that different parts of the inflatable element may be filled to different pressure levels. The inflatable element may include separately inflatable chambers. In this way, the rigidity and shape of the inflatable element is controlled by the surgeon, allowing for flexibility and ease of use.



**Published:**

- *without international search report and to be republished upon receipt of that report (Rule 48.2(g))*

## MINIMALLY INVASIVE LAPAROSCOPIC RETRACTOR

### CROSS-REFERENCE TO RELATED APPLICATIONS

[0001] This application claims the benefit of U.S. Provisional Application No. 61/429,648 filed January 04, 2011 and U.S. Provisional Application No. 61/450,682 filed March 09, 2011, which are incorporated herein by reference in their entirety.

### FIELD OF THE INVENTION

[0002] The present invention pertains to a retractor for use in laparoscopic surgery. More particularly, the present invention pertains to a minimally invasive inflatable retractor for use in laparoscopic surgery.

### BACKGROUND OF THE INVENTION

[0003] Laparoscopic surgery, also known as minimally invasive surgery, is becoming an increasingly popular method of surgery. The number of surgeons graduating each year with advance minimally invasive training continues to increase, which means that the number of minimally invasive abdominal cases will also increase. One of the most challenging aspects of laparoscopic surgery is to be able to clearly visualize the organ of concern without having to constantly clear away intestines or other nearby organs from falling into the operative field.

[0004] For example, the removal of an inflamed appendix requires the surgeon to be able to isolate this organ from its nearby surrounding tissues, such as the colon, sigmoid, ileum, jejunum, ovaries, etc. If this operation were performed openly, through a large incision, then the surgeon has the option of using sterile towels to push the other intestines and organs away from the inflamed appendix, thereby creating a clear visual field for the safe removal of the organ.

[0005] Laparoscopically, the surgeon does not have the option of using a sterile towel. The frustration is amplified by the fact that the visualized operative field through a laparoscope is very narrow and close-up, and the avalanche of intestines into the operative field is often visualized suddenly at a critical part of the dissection process. Therefore, the surgeon must constantly “clear the field” by constantly pushing the adjacent organs away as they fall back and cover up the appendix, or try to utilize the tilt function of the operating room table to hopefully allow the adjacent organs to fall away from the operative field. This is an inconsistent method of isolating the operative field, which leads to an inefficient and sometimes dangerous operation.

[0006] Various tools have been developed for retracting organs from the field of vision during surgery. However, some of these tools themselves have been known to impart damage to the organs themselves.

[0007] Accordingly, there is a need in the art for a retractor for laparoscopic surgery that removes organs from the field of vision safely and effectively.

#### SUMMARY

[0008] According to a first aspect of the present invention, an inflatable retractor comprises an inflatable element including an inner surface and an outer surface and a retractor shaft including a port for receiving insufflation pressure, wherein the inflatable element is attached to a distal end of the retractor shaft. The inflatable element is configured so as to form a compartment for retaining the organ when the inflatable element is insufflated with fluid.

[0009] According to a second aspect of the present invention, an inflatable retractor comprises an inflatable element including at least a first chamber and a second chamber and a retractor shaft including a port for receiving insufflating pressure. The inflatable element is secured to a distal end of said retractor shaft. The inflatable element is configured so as to form a

compartment when the inflatable element is insufflated with fluid. By using the term fluid, we also refer to air as a particular type of fluid that is useful.

### **BRIEF DESCRIPTION OF THE DRAWINGS**

**[0010]** The accompanying drawings provide visual representations which will be used to more fully describe the representative embodiments disclosed herein and can be used by those skilled in the art to better understand them and their inherent advantages. In these drawings, like reference numerals identify corresponding elements and:

**[0011]** FIG. 1 illustrates a perspective view of an exemplary retractor, in part, according to the features of the present invention showing the inflatable element in a deflated position.

**[0012]** FIG. 2 illustrates a perspective view of an exemplary retractor, in part, according to the features of the present invention showing the commencement of deployment of the inflatable element.

**[0013]** FIG. 3 illustrates a perspective view of the exemplary retractor in an inflated position according to the features of the present invention.

**[0014]** FIG. 4 illustrates a perspective view of the exemplary retractor in an inflated position according to the features of the present invention.

**[0015]** FIG. 4A illustrates a perspective view of a valve to be used in connection with the exemplary retractor according to the features of the present invention.

**[0016]** FIG. 5 illustrates a top plan view of the exemplary retractor in an inflated position according to the features of the present invention.

**[0017]** FIG. 6 illustrates a cross sectional view of the inflatable element positioned within an outer deployment shaft according to features of the present invention.

[0018] FIG. 7 illustrates a cross sectional view of the inflatable element in a partially inflated position according to features of the present invention.

[0019] FIG. 8 illustrates a cross sectional view of the inflatable element in another partially inflated position according to features of the present invention.

[0020] FIG. 9 illustrates a cross sectional view of the inflatable element in a fully inflated position according to features of the present invention.

[0021] FIG. 10 illustrates a cross sectional view of the inflatable element in an inflated position and showing optional bumps according to features of the present invention.

[0022] FIG. 11 illustrates a partial schematic view of a patient during laparoscopic surgery illustrating initial deployment of the inflatable retractor according to features of the present invention.

[0023] FIG. 12 illustrates a partial schematic view of a patient during laparoscopic surgery illustrating insufflation of the inflatable retractor according to features of the present invention.

[0024] FIG. 13 illustrates a partial schematic view of a patient during laparoscopic surgery illustrating engagement of the bowels by the inflatable retractor according to features of the present invention.

[0025] FIG. 14 illustrates a schematic view of a patient showing how the inflatable retractor of the present invention may be used during an appendectomy performed by laparoscopic surgery.

[0026] FIG. 15A illustrates a perspective view of another exemplary embodiment of the inflatable retractor according to features of the present invention.

[0027] FIG. 15B illustrates a perspective view of the inflatable retractor of FIG. 15B, with the crown removed.

## DETAILED DESCRIPTION OF THE PREFERRED EMBODIMENTS

[0028] The present invention pertains to an inflatable retractor used in laparoscopic surgery to retract organs from the field of vision so that laparoscopic surgery of a particular organ may be performed. However, it should be understood that the inflatable retractor of the present invention is not limited to laparoscopic use, but may be applied to a wide variety of procedures, including open surgery, thoracic surgery, and endoluminal surgery.

[0029] With reference to FIGS. 1-10, an inflatable retractor 10 includes an inflatable element 12 having an inner surface 14 and an outer surface 16, and disposed at a distal end of a retractor shaft 18, as shown, for example, in FIGS. 2-4 and 6-10. The inflatable element 12 is configured such that, when deflated, the inflatable element can be wrapped around the distal end of the shaft 12, and when inflated, the inflatable element 12 opens up like an umbrella to trap organs therein. In this way, the retractor 10 can be easily deployed without causing interference when in the deflated condition, while providing a substantial device that allows retraction of major organs when in the inflated condition.

[0030] To insufflate the inflatable element 12, the retractor shaft 18 is hollow and includes a port 20 which communicates with an internal channel (not shown) for receiving insufflating fluid such as air (FIG. 4), which causes the inflatable element 12 to expand and inflate. The size of the internal channel of the retractor shaft may be sufficiently large to allow another laparoscopic instrument (e.g., a grasper) to be deployed through the internal channel, thereby allowing the retractor 10 be used as an extended trocar. A 5 mm camera may also be placed through the internal channel of the retractor 10 to minimize visual impedance by the retractor 10. In addition, while the port 20 is shown in FIG. 4 as being at the proximal end of the retractor shaft 18, it should be understood that it may be at any location on the retractor shaft 18 that remains

outside the patient's body during the procedure. For example, FIGS. 11-13 show the port 20 being located at the side of the retractor shaft 18. In this way, a valve 22 is associated with port 20 to allow a surgeon to control insufflating the inflatable element 12.

[0031] With reference back to FIG. 4, the inflatable element 12 is configured so as to form a compartment 24 when the inflatable element 12 is insufflated with fluid. A "compartment" is hereby defined as a 3-dimensional volumetric space, which can retain organs therein. In this way, a "compartment" is like a bowl or an upside down umbrella, so that at least a portion of the organ or tissue can be constrained inside the compartment. As such, the compartment 24 acts to trap organs behind it, so that organs may be cleared from the field of vision. As shown in FIG. 4, the compartment 24 is preferably umbrella shaped. However, the compartment 24 may be any other shape, depending upon application and design preference. For example, the compartment 24 may be flatter and v-shaped to bluntly isolate organs, such as the gallbladder, or for safe dissection of adhered intra-abdominal planes.

[0032] Similarly, the inflatable element 12 is shown as being circular. However, other shapes are possible, including but not limited to, oval, rectangular, diamond, triangular, or square. In addition, while the inflatable element 12 is shown as being symmetrical, it should be understood that the inflatable element 12 may be asymmetrical, depending on application and design preference. In this way, the inflatable element 12 may be manufactured to any specific size or configuration to accommodate the operation, depending on application and design preference.

[0033] Preferably, the inflatable element 12 is made from a material that becomes rigid once inflated and has a sufficient tensile strength to hold large organs, such as the bowels that could weigh as much as 5 pounds. In addition, the inflatable element 12 is preferably made of an inert compound, so as to not aggravate patients with latex allergies. Examples of materials include,

but are not limited to, any plastic or polymer based materials, such as polyurethane, silicone, and polyethylene.

[0034] In addition, the inflatable element 12 should be sufficiently sized and configured to hold particular organs at issue. For example, in the case of retracting bowels, the width of the inflatable element 12 may be up to 50-75% of the cross sectional view of the abdominal cavity. In addition, inflatable element 12 should be sufficiently thick so as to prevent the inflatable element 12 from turning inside out. However, other sizes and shapes are possible, depending upon application and design preference. Similarly, the retractor shaft 18 should be made from a material that is rigid and sturdy, and able to hold the inflatable element 12 and the organs retained therein. Such materials include, but are not limited to, polyethylene, silicone, polyurethane or any plastics or polymer based material.

[0035] To further prevent the inflatable element 12 from turning inside out, a support structure 25 may be positioned between the inflatable element 12 and the retractor shaft 18 (FIG. 4). Preferably, the support structure 25 is configured and sized to provide maximum support, while taking up minimum space. In the preferred embodiment, the support structure 25 is inflatable and made from the same material as the inflatable element 12. However, the particular shape, configuration and material of the support structure 25 will depend upon application and design preference.

[0036] With reference to FIGS. 4, 5, and 7, valves 27 are provided at various locations within the inflatable element 12 to control insufflation of various parts of the inflatable element 12.

With reference to FIG. 4A, the valve 27 is configured to include a partition 29 down the middle, which may be twisted 90 to 180 degrees, which acts as a flow restrictor. The twistable partition 29 makes it a plug at low insufflation pressures, which requires more back pressure to insufflate

the first compartment. After adequate insufflation, it allows air to pass and fill up the second compartment, to allow for “staged” insufflation of the retractor 10.

[0037] According to a preferred embodiment as shown in FIGS. 4, 5, and 7, the valves 27 are placed at strategic locations between the inner surface 14 and outer surface 16 of the inflatable element 12 so as to form staged insufflation of the inflatable element 12. According to the preferred embodiment shown in FIG. 4A, staged insufflation may proceed, whereby the first insufflatable chamber 31A is filled first (see FIG. 7), followed by the second insufflatable chamber 31B, and then the third insufflatable chamber 31C.

[0038] For example, the inflatable element 12 may be designed such that when the first inflatable chamber 31A reaches a predetermined insufflation pressure, the valves 27 positioned between the first inflatable chamber 31A and second inflatable chamber 31B open to allow fluid into the second inflatable chamber 31B. Similarly, when the second inflatable chamber 31B reaches a predetermined insufflation pressure, the valves 27 positioned between the second inflatable chamber 31B and the third inflatable chamber 31C open to allow fluid into the third inflatable chamber 31C.

[0039] In another exemplary embodiment as shown in FIGS. 15A and 15B, two independent and separate chambers 33A and 33B are illustrated. In this way, one or more tubes may be used to insufflate each chamber independently, allowing for varying pressures in each chamber. For example, the outer rim or crown 33A of the inflatable element 12 may be filled with less pressure so as to minimize damage to bowels during retraction, while a rigid base with a greater pressure would provide more stability to the device. The second chamber 33B may include support elements S, connected by an extra tubular section T, which connects the tubular section T and support elements S to a single sphere.

[0040] Accordingly, the insufflation pressure of the different chambers 33A and 33B may be controlled by the user to obtain specific and/or different pressures in each chamber. In addition, each of the support elements S may be separately inflatable, allowing for an asymmetric pumping of the inflatable element, thereby achieving a single larger side observation window.

[0041] While two chambers are shown in the exemplary embodiment, it should be understood that any number of chambers may be used depending upon application and design preference. To aid in attachment to surrounding tissue to maximize retraction potential, the inner surface 14 may include bumps 28, as shown in FIG. 10. In addition, the outer edge 26 of the inflatable element 12 (FIG. 4) may be wedged or scalloped, to further aid in adhesion of the surrounding tissue. Importantly, there should be no sharp edges or hard substances on the inflatable element 12 to potentiate bowel injury or vessel damage. However, the bumps 28 and wedged outer edge 26 are not necessary, particularly if inflatable element 12 is made from material having a sufficiently high surface roughness.

[0042] With reference to FIGS. 3-5, a plurality of windows 30 may be disposed through the inflatable element 12. The windows 30 should be sufficiently large so as to enable a field of vision beyond the outer surface 16 of the retractor 10. That is, the windows 30 should be sized to allow the surgeon to see behind the retractor 10. The windows 30 may be any size or shape, and in any pattern or configuration, depending on application and design preference. In addition, the windows 30 also should be sufficiently sized to allow for other instruments to be positioned there through, as will be described in more detail below.

[0043] With reference to FIGS. 7-9, the inflatable element 12 may be insufflated to different levels, such that a configuration of the compartment 24 changes according to the insufflating level. For example, in the particular embodiment shown in FIGS. 7-9, the amount of concavity

of the inflatable element 12 is adjustable by changing the insufflation pressure of the inflatable element 12. As shown in FIG. 7, a more compact, deeper compartment is possible when the inflatable element 12 is insufflated to a lower level. In this way, the angle  $\alpha$  formed between a longitudinal axis of the retractor shaft 18 and a predominant axis of the inflatable element 12 is relatively small. Comparatively, a flatter compartment is shown in FIG. 8, wherein the inflatable element 12 is insufflated to a medium level. In this way, the angle  $\alpha_1$  formed between a longitudinal axis of the retractor shaft 18 and a predominant axis of the inflatable element 12 is greater than the angle  $\alpha$  from FIG. 7.

[0044] Still, a further flattened compartment 24 is shown in FIG. 9, wherein the inflatable element 12 is insufflated to a high level. In this way, the angle  $\alpha_2$  formed between a longitudinal axis of the retractor shaft 18 and a predominant axis of the inflatable element 12 is greater than the angle  $\alpha$  from FIG. 7 and angle  $\alpha_1$  from FIG. 8. Preferably, the angle  $\alpha$  formed between a longitudinal axis of the retractor shaft 18 and a predominant axis of the inflatable element is between 0 and 90 degrees, and more preferably, between 20 and 70 degrees. Importantly, the angle must be chosen so that the retractor does not turn inside out during use. The optimum angle chosen will also depend upon the size, thickness and configuration of the inflatable element.

[0045] With reference, for example, to FIG. 7, the level of insufflating is under complete control of the surgeon by way of valve 22. By operating the valve 22, the surgeon may control the rate of insufflation, as well as the final rigidity and shape of the retractor 10. As such, the insufflation process may be operated in a gentle way to retract and separate intestines, even in the setting of adhesion. However, it should be understood that other types of mechanisms for

insufflating the inflatable element may be used, depending upon application and design preference.

[0046] For example, a pressure indicator may be included, which indicates the pressure of the inflatable element 12. The pressure indicator may be correlated to the inflatable element 12, such that certain chambers of the inflatable element 12 collapse when the pressure exceeds a predetermined level. As such, the fully inflated element 12 allows for a built in load limiter which limits the load applied to the intestine. In addition, the correlation between the collapsing value and the internal pressure level may be preset, and the user should be instructed on what volume of air should be pumped into the trocar.

[0047] With reference to FIGS. 1, 2 and 6, deployment of the retractor 10 will be described in more detail. In particular, the inflatable element 12 may be housed in an outer deployment shaft 34. Preferably, the outer deployment shaft 34 is adapted to retain the inflatable element 12 therein when in the deflated condition, as shown, for example, in FIGS. 1, 2, and 6. In this way, the inflatable element 12 is positioned around the retractor shaft 18, and nestled within the inner channel of the outer deployment shaft 34.

[0048] With reference to FIGS. 11-14, the outer deployment shaft 34 may be constructed as a standard trocar-induced cannula. In particular, the outer deployment shaft 34 may include a cannula 36 at a distal or insertion end 38 for penetration into body of a patient, and a proximal end 40 having a cannula handle 42 maintained outside the body of the patient. The outer deployment shaft 34 may be made from a material that is easily sterilized, biocompatible, and durable, such as polyethylene, and the like.

[0049] While retractor 10 is illustrated in connection with an outer deployment shaft 34, it should be understood that the retractor 10 may be inserted inside any laparoscopic port without

the use of the outer deployment shaft 34. In this way, the retractor is inserted directly into an existing port. As such, the retractor 10 is not limited to any particular housing or shaft, or method of insertion into a patient's body.

[0050] With reference to FIGS. 11-13, the retractor 10 may be deployed through a standard trocar, such as a 10/12 mm trocar, although any sized trocar is possible, depending upon application and design preference. For example, the retractor 10 may be designed to fit through 5 mm trocars to optimize efficiency.

[0051] With particular reference to FIG. 11, the retractor 10 may be inserted into a port 44 of the body 46 of a patient. In particular, the retractor 10 is moved out of the outer deployment shaft 34 towards the organ to be retracted. As described above, the outer deployment shaft 34 may be part of a trocar-induced cannula, but may also be a separate shaft, as shown, for example, in FIG. 4. During deployment of the retractor 10, the inflatable element 12 remains in a deflated condition. As described above, the surface roughness of the material of the inflatable element 12 preferably allows it to stay positioned about the retractor shaft 18 during deployment. This self-adhesive ability would also allow the inflatable element 12 to be deployed into an existing port without an outer deployment shaft, as described above.

[0052] With continued reference to FIG. 11, the retractor 10 is directed past the organ it is intended to retract. As shown in FIG. 11, the retractor 10 is positioned below the bowels 48. Once the retractor 10 is appropriately positioned, the surgeon operates valve 22 to inflate the inflatable element 12, as shown in FIG. 12. In particular, a pump 50 may be provided to direct insufflation fluid to the inflatable element 12. The inflatable element 12 may be filled with any type of fluid, including but not limited to, liquid such as saline and air such as CO<sub>2</sub>. The pump 50 may be the same source providing CO<sub>2</sub> to insufflate the abdomen, or may be a separate

source, depending on application or design preference. For example, a hand-held pump similar to one used to take blood pressure, may be provided. The pump preferably is designed to attach onto the insufflation port, which would allow a surgeon to manually pump the appropriate amount of fluid into the inflatable element.

[0053] Moreover, as described above, the surgeon controls the level of insufflation of the retractor 10 by controlling valve 22. That is, the retractor 10 may be filled to different levels, as shown for example, in FIGS. 7-9, with the final shape and rigidity of the inflatable element 12 depending on the amount of fluid that is insufflated into the system. As the inflatable element 12 is insufflated with fluid, the inflatable element 12 opens up and moves away from the retractor shaft 18, similar to the opening of an umbrella. Once the appropriate orientation, size, and rigidity are achieved, the inflatable element 12 is set to trap and hold the organs behind it.

[0054] With reference to FIG. 13, once the organs (and in this case, the bowels 48) are trapped within the inflatable element 12, the surgeon pulls back on the retractor shaft 18 to clear the field of view of the surgical area 52. As shown in FIG. 13, the retractor 10 may be secured into place by way of clamp 54. Preferably, the clamp 54 is circular and includes inner ridges (not shown) which mate with outer ridges 56 on the exterior surface of the retractor shaft 18, keeping the retractor 10 in place. The corresponding ridges allow the clamp to anchor the retractor 10 onto the outer deployment shaft 34 or cannula, without allowing it to slide. Preferably, the clamp 54 is hinged, and has a simple locking mechanism (such as a latch) to allow it to close circumferentially around the retractor shaft 18. When closed, the clamp 54 rests on top of the outer deployment shaft 34 or cannula and prevents the retractor 10 from sliding within the outer deployment shaft 34, thereby potentially obviating the need of additional assistance.

[0055] A laparoscope (not shown) can then be advanced either past the balloon, or through the windows 30 to keep it out of the visual field. In addition, one or more surgical tools 58 may be advanced through other ports via a cannula 59 or the like to perform the particular laparoscopic procedure. Once the operation is complete, the inflatable element 12 may be deflated by opening up valve 22, and removing the deflated inflatable element 12 from the body of the patient.

Alternatively, the inflatable element 12 may be easily punctured, so that the insufflation fluid falls into the body of the patient, before the deflated inflatable element 12 is removed, allowing for quick removal.

[0056] The retractor 10 according to the features of the present invention is easily deployable and mobile. It has a variable shape and rigidity, which is controlled by the surgeon or assistant. As such, the retractor 10 may be particularly helpful to surgeons having high volumes, or who will be operating on deeper structures in the abdominal cavity or pelvis, where a still operative field is necessary for fine and intricate dissection. It also allows for consistent and atraumatic retraction of the adjacent organs for a safer and more efficient operation to be performed.

[0057] In addition, the retractor 10 of the present invention allows for the safe and consistent isolation and retraction of adjacent organs to allow clear visualization of the target organ of interest. It can be used in multiple quadrants of the abdomen, and will not cause injury to healthy intestines or solid organs. It is easily deployed through a laparoscopic port, and does not require advanced laparoscopic training to use.

#### EXAMPLE 1

[0058] With reference to FIG. 14, use of the retractor 10 of the present invention is described in connection with abdominal surgery. In particular, the surgeon makes an infraumbilical incision with a Hasson trocar 60 and safely enters the abdominal cavity. The patient 62 has

adhesions in the right lower quadrant of the abdomen due to an inflamed appendix 64. A first 5 mm trocar 66 is inserted in the supra-pubic position and a second 5 mm trocar 68 is placed into the left lower quadrant. The retractor 10 is deployed through an incision 70 in the left upper quadrant cannula 34, and graspers (not shown) are placed in the 5 mm trocars 66 and 68. The inflatable element 12 is brought into view. The intestines are retracted toward the left upper quadrant away from the appendix 64, and the inflatable element 12 is deployed by insufflation.

[0059] As the inflatable element 12 opens like a spiraling umbrella, the inflatable element 12 systematically traps the intestines behind it. The surgeon may help by gently positioning the intestines behind the inflatable element. The insufflation pressure of the inflatable element 12 is adjusted by the surgeon to provide adequate retraction and rigidity. The retractor 10 is then pulled back towards the left upper quadrant to create more space around the appendix 64. The laparoscope position may be adjusted so that the view is unimpeded by the retractor 10. This can be done by further retracting the inflatable element 12 away from the field, or by adjusting the scope so that it is looking through the windows 30 of the inflatable element 12. The appendix 64 is then clearly visualized, the operative field is free of cascading intestines and the operation is safely and efficiently performed. Once the appendix 64 is removed, the inflatable element 12 is desufflated and the retractor 10 is removed from the abdominal cavity.

[0060] While the inflatable retractor 10 has been described primarily in connection with retracting organs from the field of vision during laparoscopic surgery, it should be understood that it may have different uses, including but not limited to, as a dissection tool for the dissection of a target organ or adhered planes. For example, the insufflating property of the retractor 10 will allow it to safely open adhered planes in an atraumatic fashion. The retractor 10 may also be useful for hemostasis or tamponade bleeding. In particular, the inert material will allow it to

be used as a compressive device to minimize bleeding from an injured vessel or gastrointestinal spillage from an enterotomy. The retractor 10 may also be used for thoracic surgery to isolate the lung or pulmonary vessel. However, it should be understood that the retractor 10 may have many different uses, depending upon application and design preference.

[0061] Although the present invention has been described in connection with preferred embodiments thereof, it will be appreciated by those skilled in the art that additions, deletions, modifications, and substitutions not specifically described may be made without departing from the spirit and scope of the invention as defined in the appended claims.

**CLAIMS**

1. An inflatable retractor, comprising:  
an inflatable element including an inner surface and an outer surface;  
a retractor shaft including a port for receiving insufflating pressure, said inflatable element being secured to a distal end of said retractor shaft;  
wherein inflatable element being configured so as to form a compartment when said inflatable element is insufflated with fluid.
2. The retractor of claim 1, wherein the compartment is concave.
3. The retractor of claim 1, wherein the compartment is v-shaped.
4. The retractor of claim 1, wherein the inflatable element includes a plurality of windows, said windows sufficiently large to enable a field of vision beyond the outer surface the retractor.
5. The retractor of claim 1, wherein the inner surface of the inflatable element includes raised bumps.
6. The retractor of claim 1, wherein the inflatable element is positioned around the retractor shaft in a deflated condition prior to first use.

7. The retractor of claim 1, wherein said port is operatively connected to a valve for insufflating and desufflating of the inflatable element to a range of insufflations levels, wherein a configuration of said compartment changes according to said insufflating level.
8. The retractor of claim 1, further including a clamp for releasably positioning the retractor into a fixed position after an organ is positioned within the compartment and retracted from a field of vision.
9. The retractor of claim 1, further including an outer deployment shaft, said outer deployment shaft disposed about said retractor shaft, and adapted to surround the inflatable element when in the deflated condition.
10. An inflatable retractor, comprising:
  - an inflatable element including at least a first chamber and a second chamber;
  - a retractor shaft including a port for receiving insufflating pressure, said inflatable element being secured to a distal end of said retractor shaft;
  - wherein inflatable element being configured so as to form a compartment when said inflatable element is insufflated with fluid.
11. The inflatable retractor of claim 10, wherein the first chamber and second chamber are separately inflatable.
12. The inflatable retractor of claim 11, wherein the first chamber and second chamber are inflatable through separate ports.

13. The inflatable retractor of claim 10, wherein the first chamber and second chamber are inflatable through a single port.
14. The inflatable retractor of claim 10, wherein the compartment is concave.
15. The retractor of claim 10, wherein the compartment is v-shaped.
16. The retractor of claim 10, wherein the inflatable element includes a plurality of windows, said windows sufficiently large to enable a field of vision beyond the outer surface the retractor.
17. The retractor of claim 10, wherein the inner surface of the inflatable element includes raised bumps.
18. The retractor of claim 10, wherein the inflatable element is positioned around the retractor shaft in a deflated condition prior to first use.
19. The retractor of claim 10, wherein said port is operatively connected to a valve for insufflating and desufflating of the inflatable element to a range of insufflations levels, wherein a configuration of said compartment changes according to insufflating level.
20. The retractor of claim 10, further including a clamp for releasably positioning the retractor into a fixed position after an organ is positioned within the compartment and retracted from a field of vision.

21. The retractor of claim 10, further including an outer deployment shaft, said outer deployment shaft disposed about said retractor shaft, and adapted to surround the inflatable element when in the deflated condition.

1/11

FIG. 1

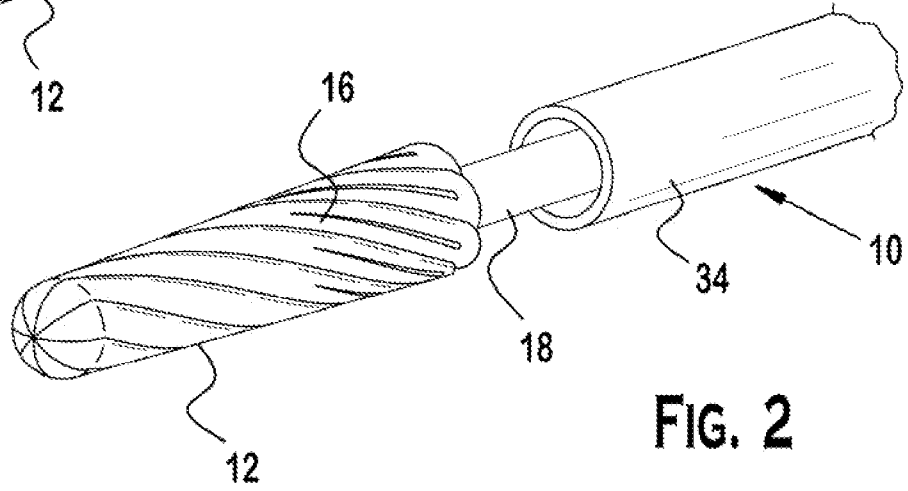
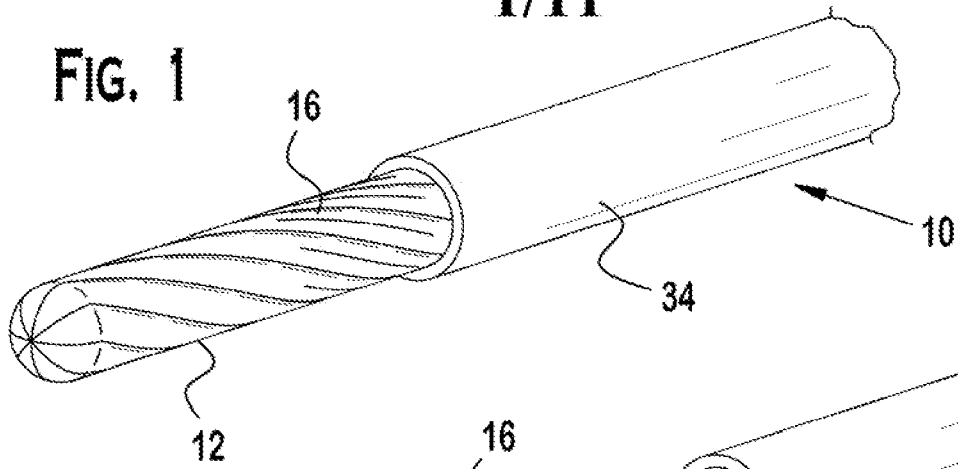

FIG. 2

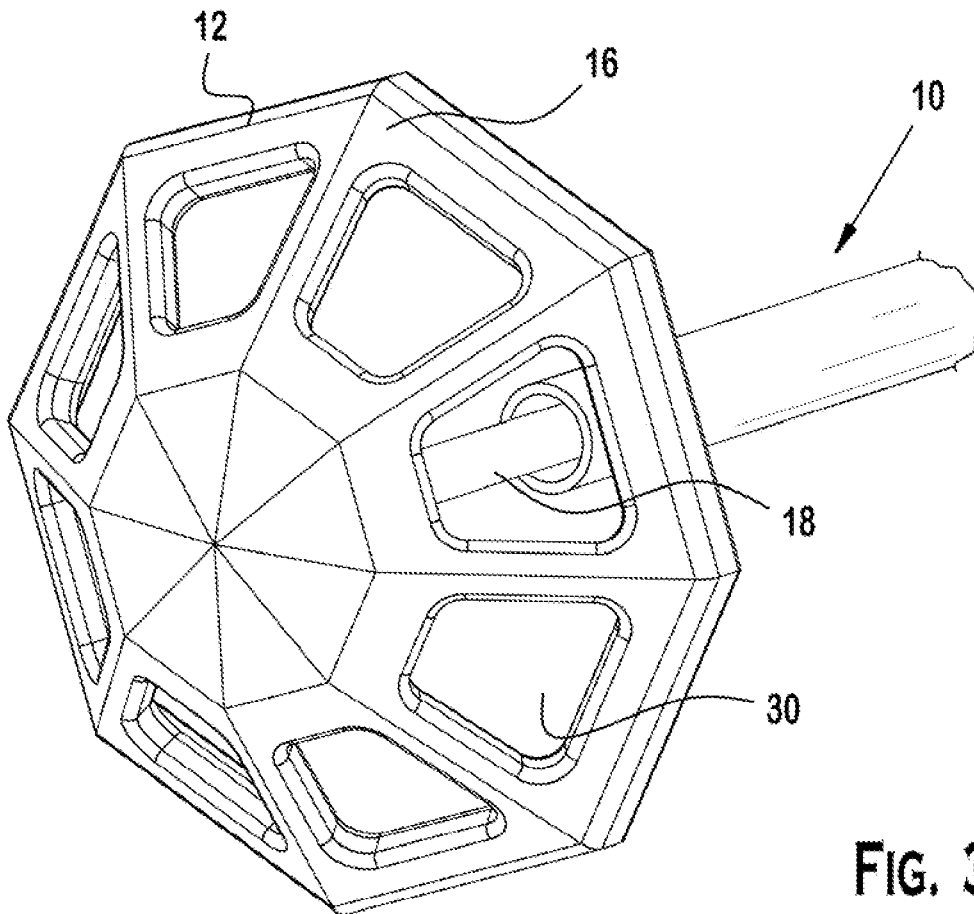
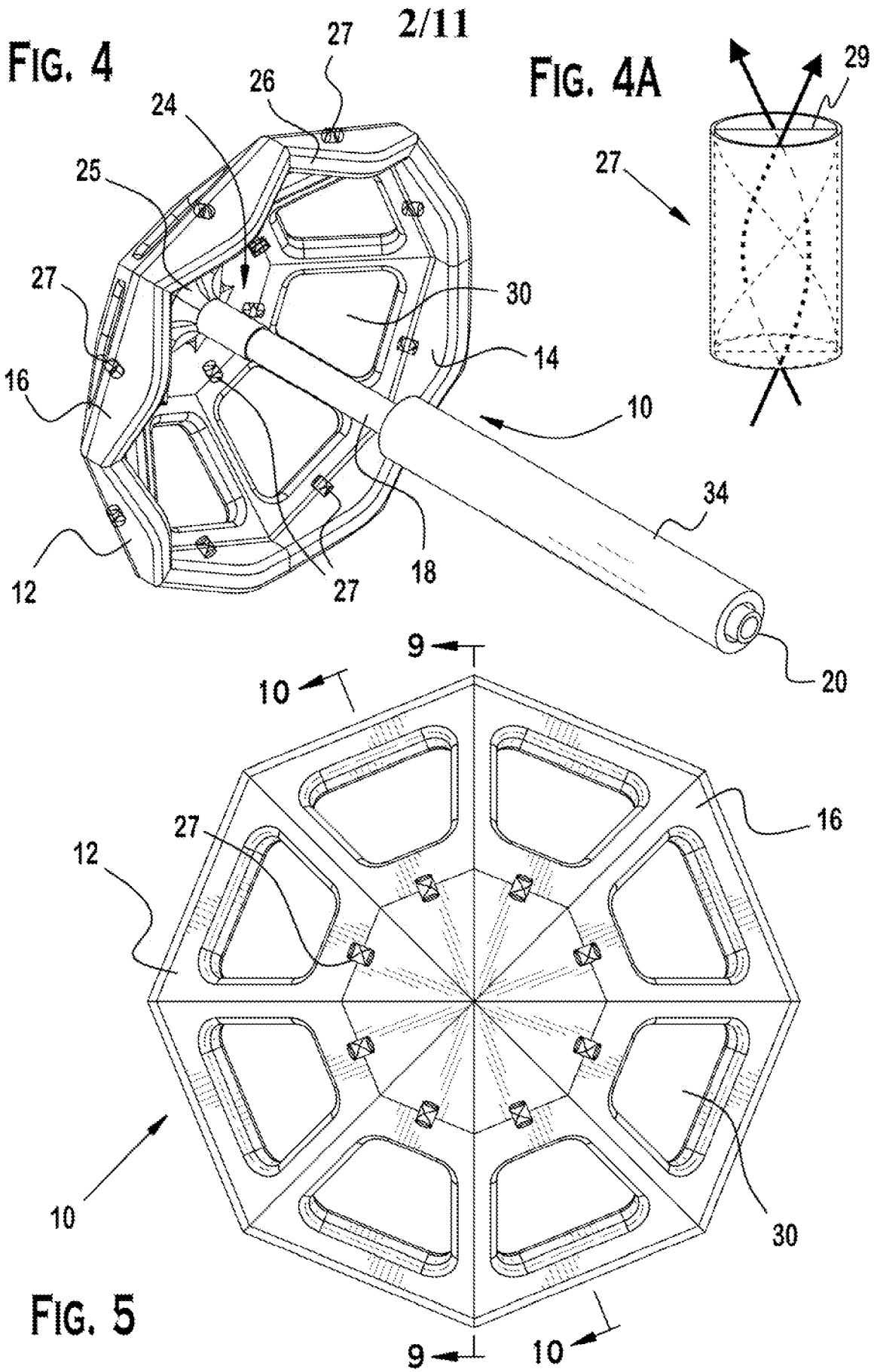
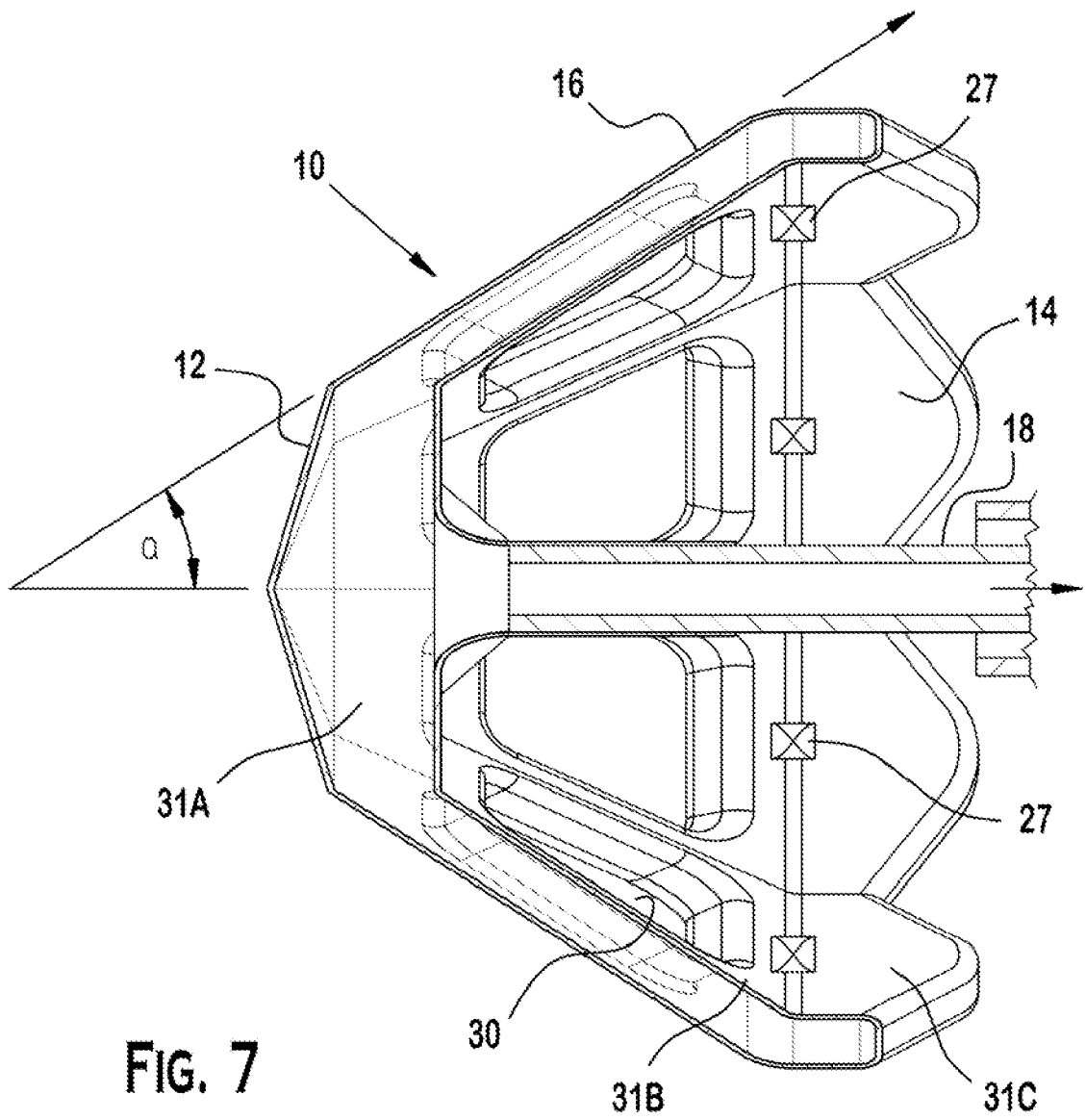
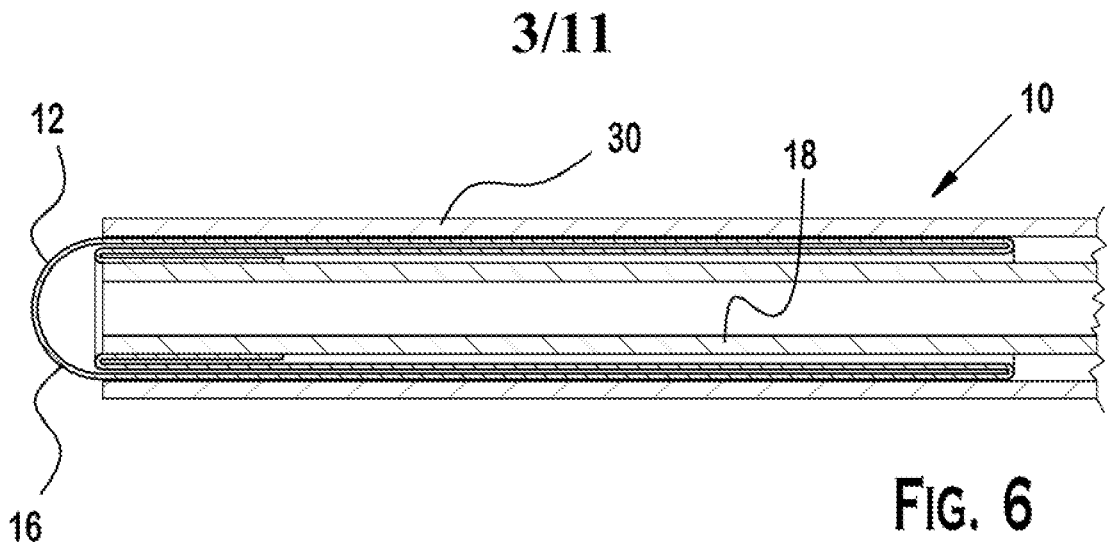

FIG. 3





4/11

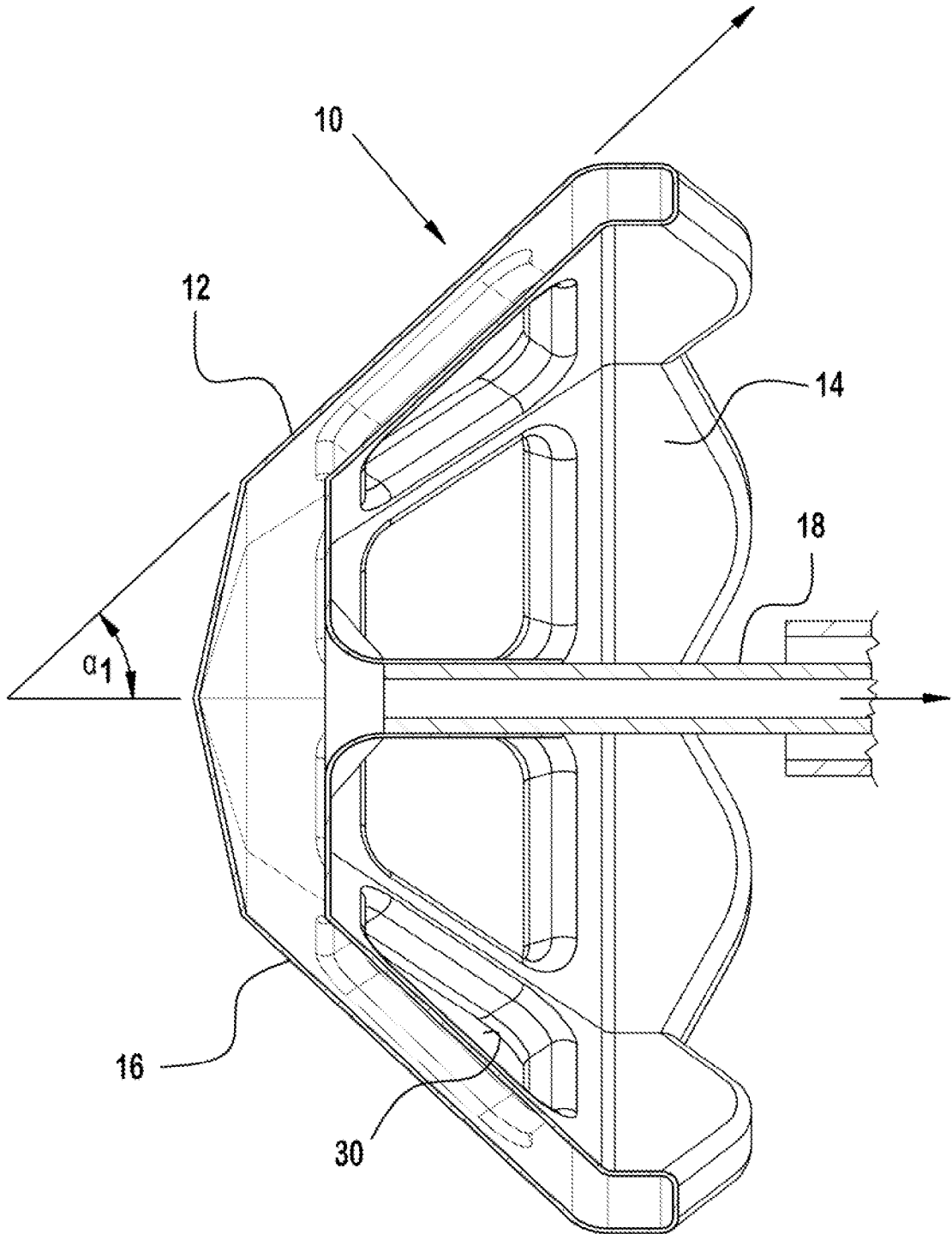
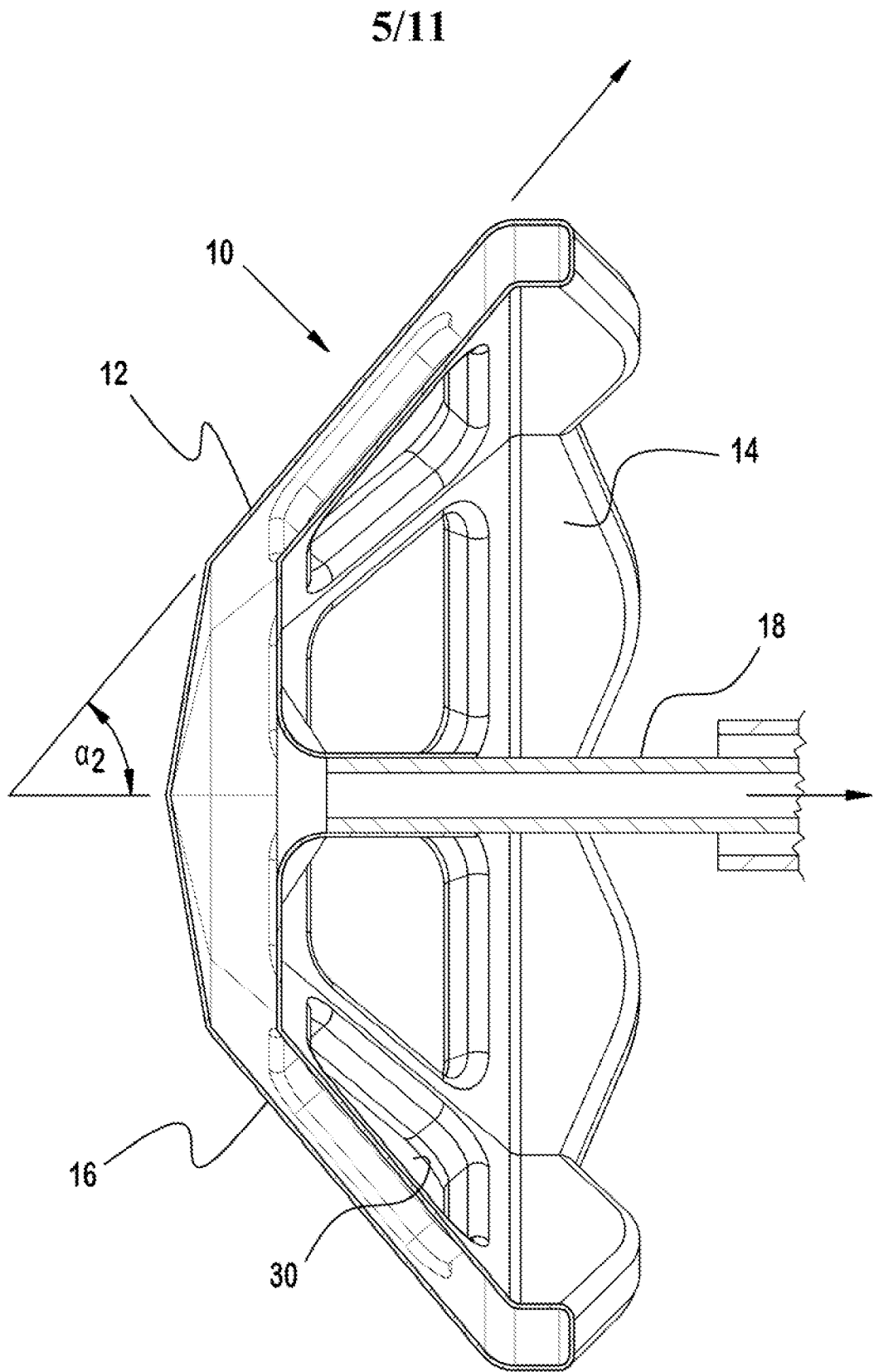

FIG. 8



6/11

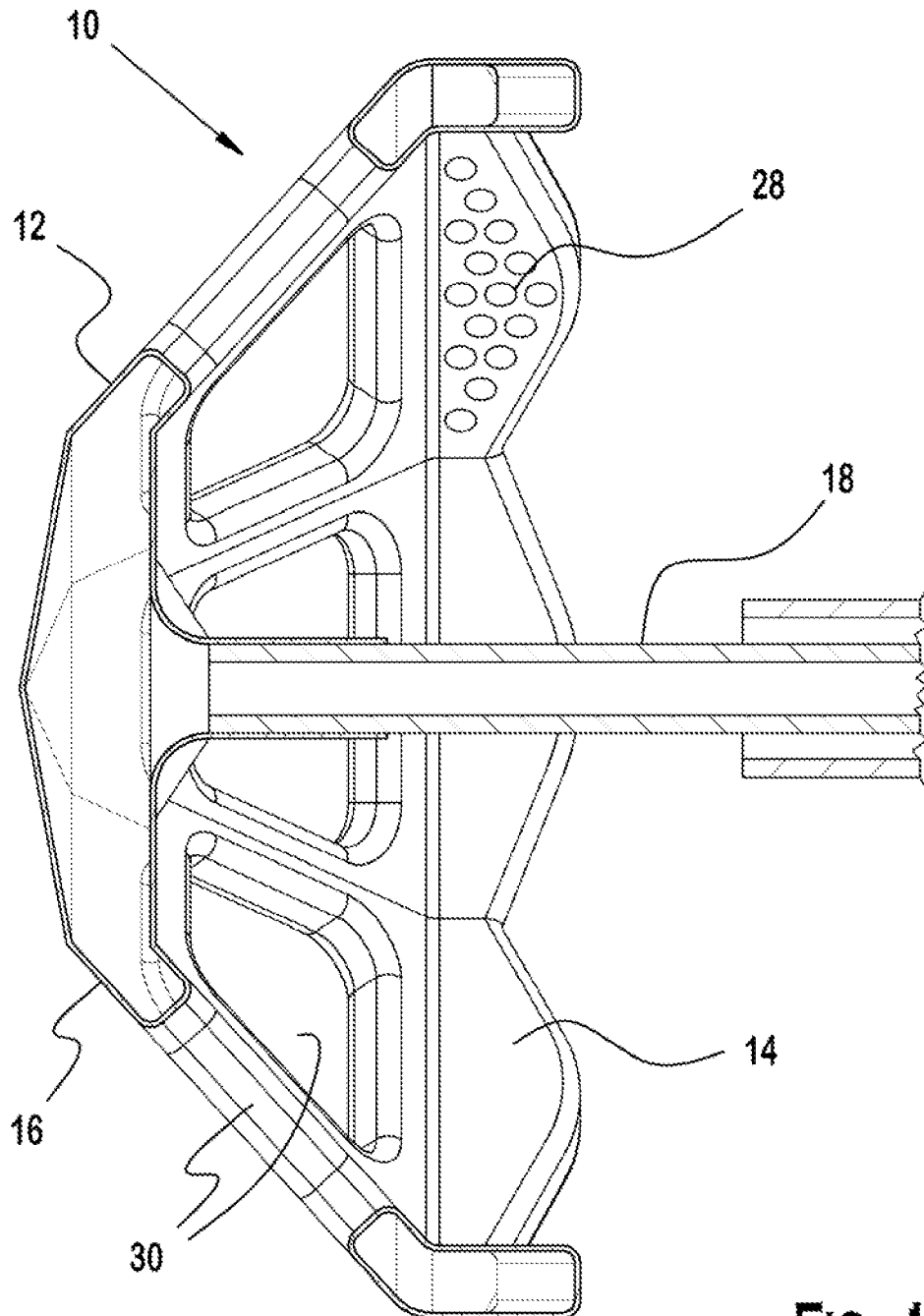

FIG. 10

7/11

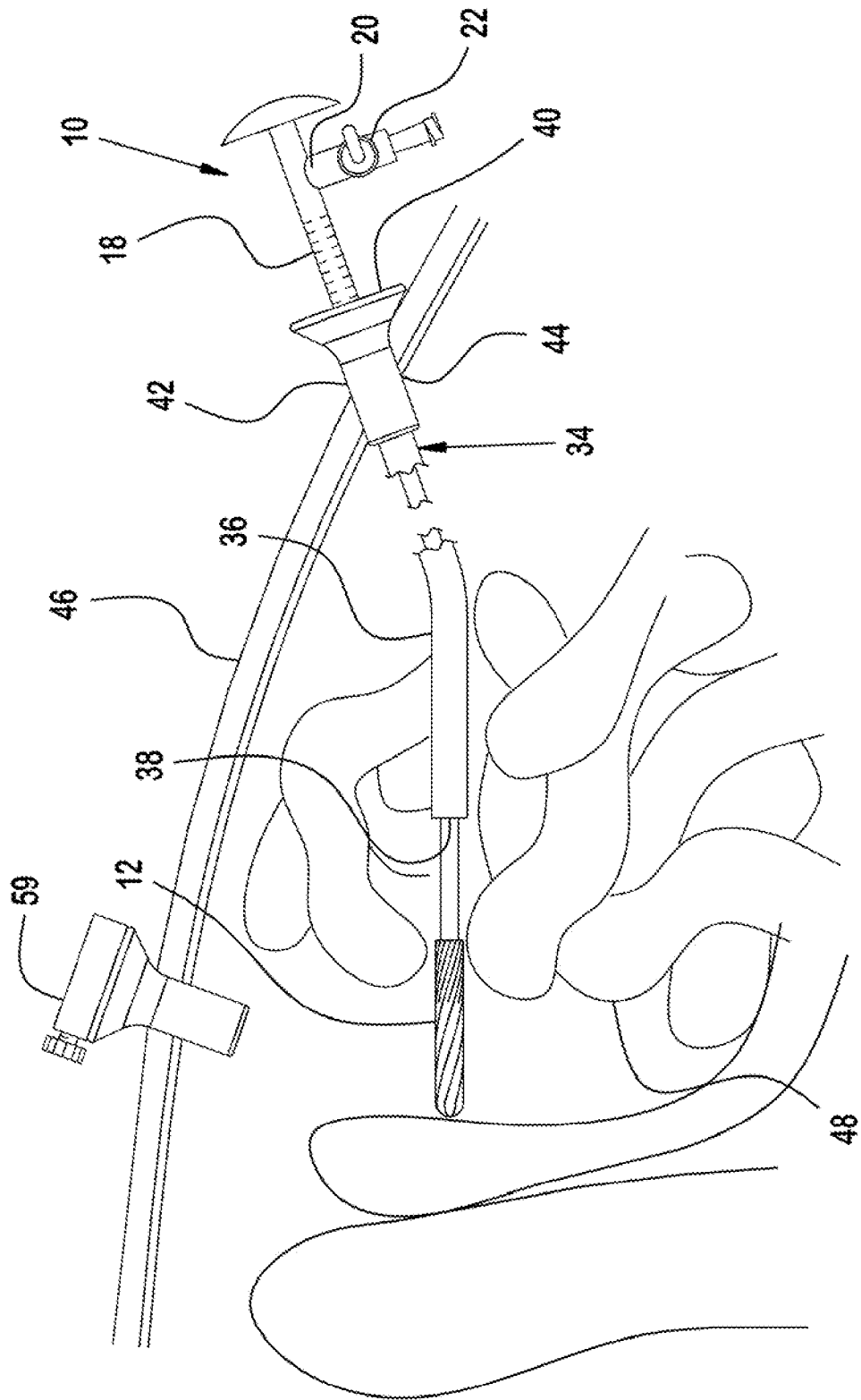

FIG. 11

8/11

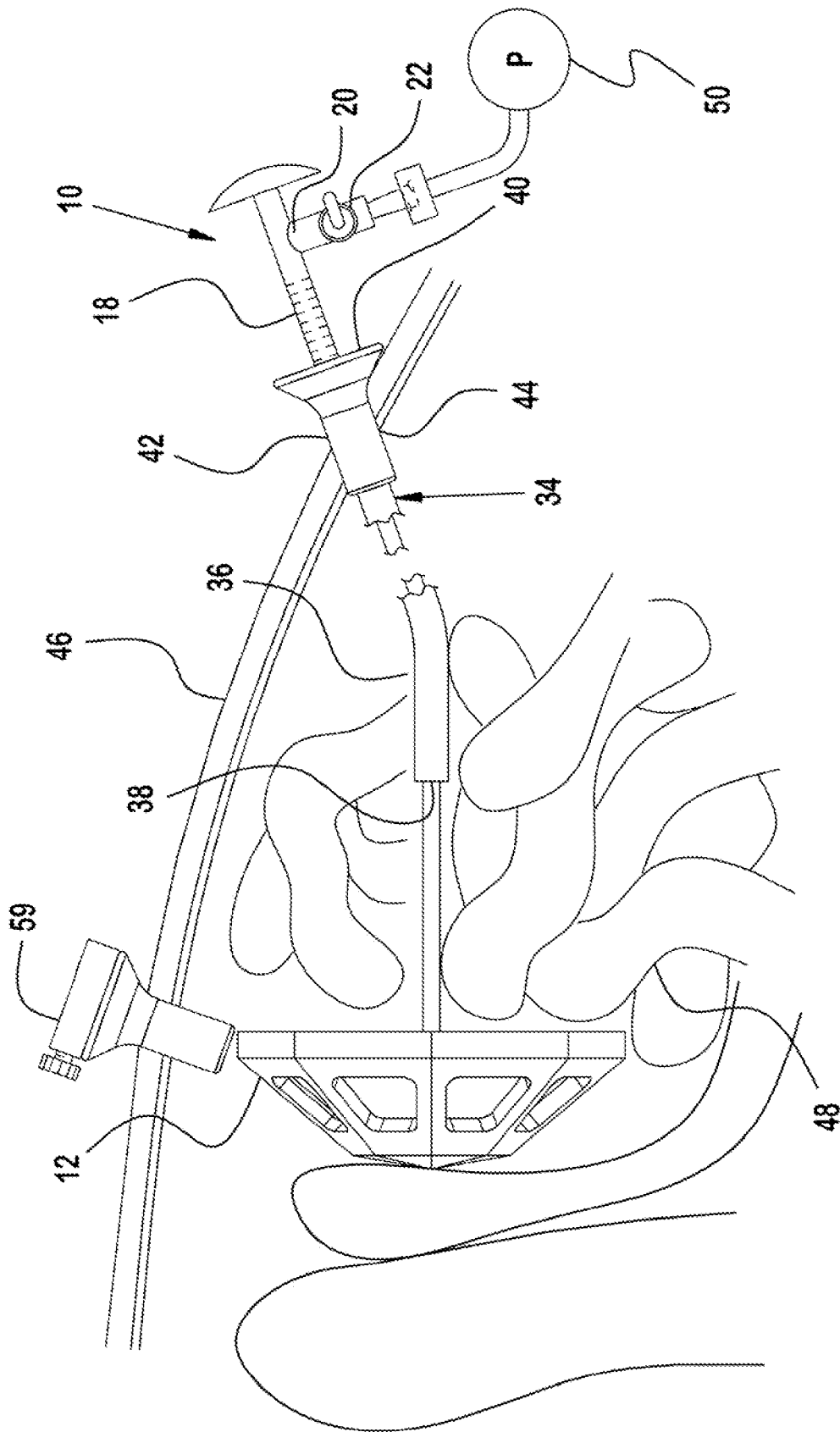

FIG. 12



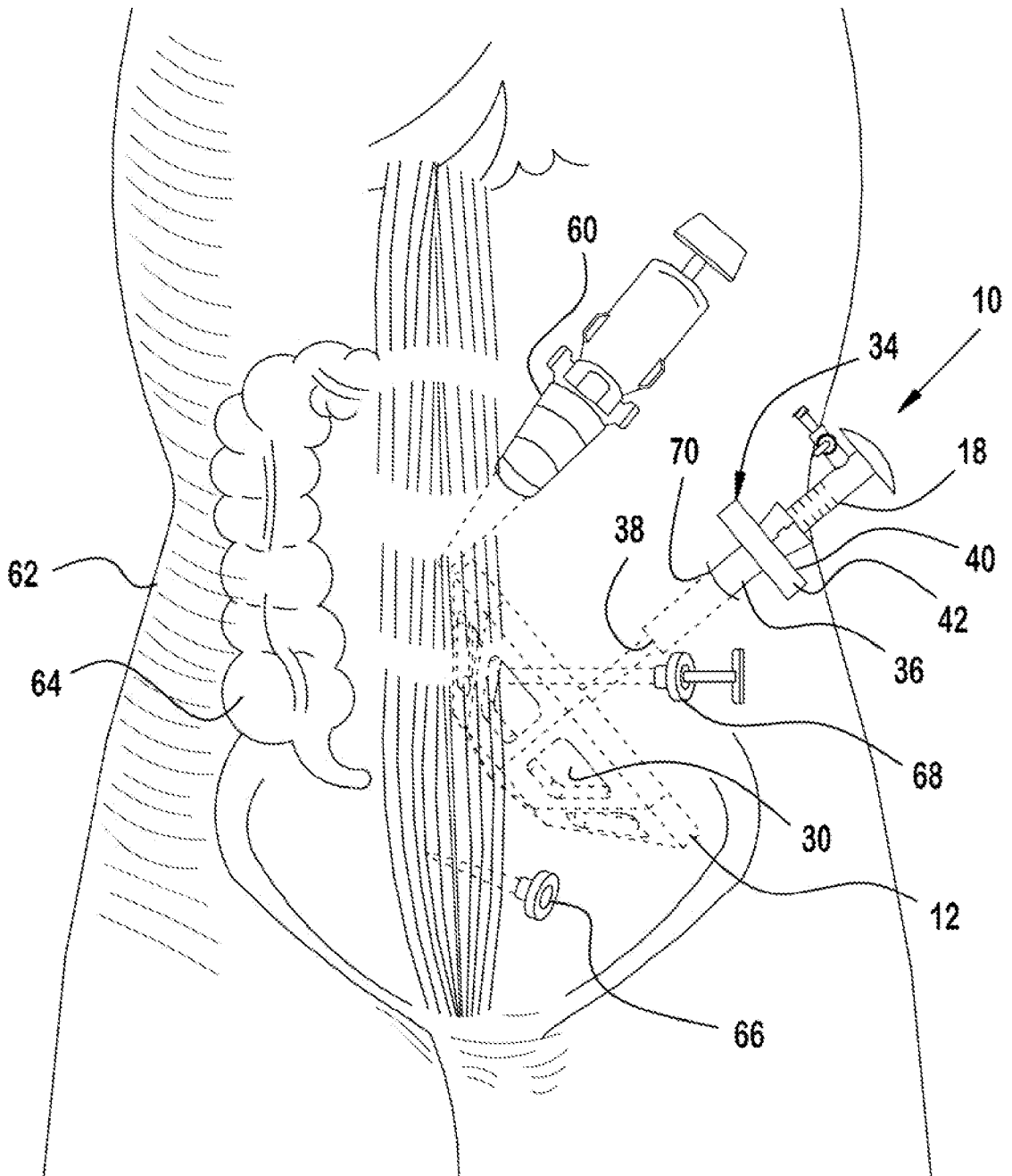
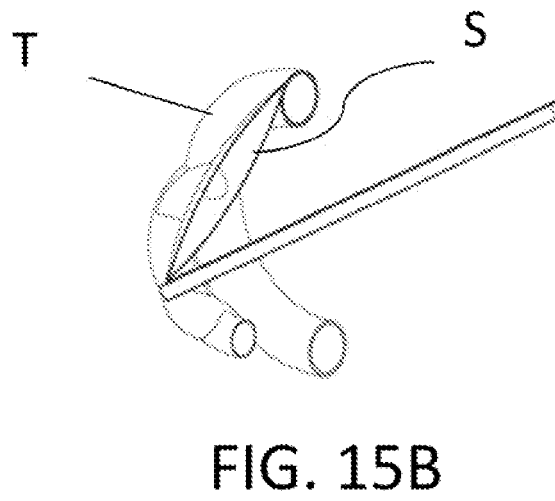
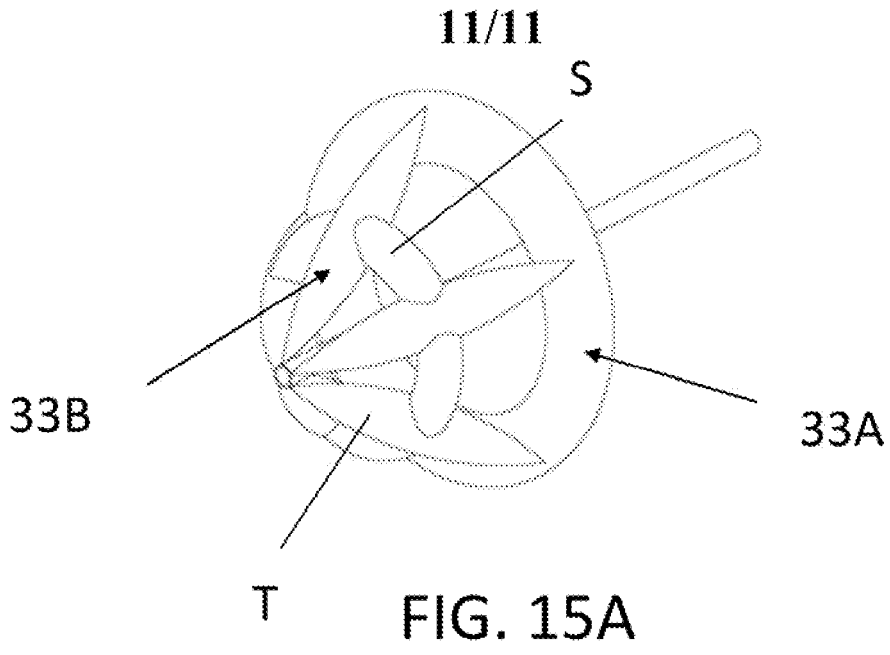

FIG. 14



专利名称(译)	微创腹腔镜牵开器		
公开(公告)号	<a href="#">EP2661231A2</a>	公开(公告)日	2013-11-13
申请号	EP2012732225	申请日	2012-01-04
[标]申请(专利权)人(译)	约翰霍普金斯大学		
申请(专利权)人(译)	约翰·霍普金斯大学		
当前申请(专利权)人(译)	约翰·霍普金斯大学		
[标]发明人	NGUYEN HIEN TAN		
发明人	NGUYEN, HIEN TAN		
IPC分类号	A61B17/02 A61M29/02 A61M25/10 A61B17/94 A61F2/958		
CPC分类号	A61B17/0218 A61B1/32 A61B17/02 A61B17/0281 A61B2017/00557 A61B2017/0212		
优先权	61/450682 2011-03-09 US 61/429648 2011-01-04 US		
其他公开文献	EP2661231A4		
外部链接	<a href="#">Espacenet</a>		

#### 摘要(译)

用于患者身体的腹腔镜手术的可充气牵开器包括设置在牵开器轴的远端的可充气元件。牵开器轴包括用于接收注入流体的端口。可膨胀元件设计成使得可膨胀元件的不同部分可以填充到不同的压力水平。可膨胀元件可包括单独的可膨胀腔室。以这种方式，可膨胀元件的刚度和形状由外科医生控制，允许灵活性和易用性。