

(19) World Intellectual Property Organization
International Bureau



(43) International Publication Date
10 November 2005 (10.11.2005)

PCT

(10) International Publication Number
WO 2005/104927 A2

(51) International Patent Classification⁷: A61B 1/01, 1/04

(74) Agents: HESLIN, James, M. et al.; Townsend and Townsend and Crew LLP, Two Embarcadero Center, 8th Floor, San Francisco, CA 94111-3834 (US).

(21) International Application Number:

PCT/US2005/009393

(81) Designated States (unless otherwise indicated, for every kind of national protection available): AE, AG, AL, AM, AT, AU, AZ, BA, BB, BG, BR, BW, BY, BZ, CA, CH, CN, CO, CR, CU, CZ, DE, DK, DM, DZ, EC, EE, EG, ES, FI, GB, GD, GE, GH, GM, HR, HU, ID, IL, IN, IS, JP, KE, KG, KP, KR, KZ, LC, LK, LR, LS, LT, LU, LV, MA, MD, MG, MK, MN, MW, MX, MZ, NA, NI, NO, NZ, OM, PG, PH, PL, PT, RO, RU, SC, SD, SE, SG, SK, SL, SM, SY, TJ, TM, TN, TR, TT, TZ, UA, UG, US, UZ, VC, VN, YU, ZA, ZM, ZW.

(22) International Filing Date: 22 March 2005 (22.03.2005)

(25) Filing Language: English

(26) Publication Language: English

(30) Priority Data:

10/824,936 14 April 2004 (14.04.2004) US
11/036,029 14 January 2005 (14.01.2005) US

(84) Designated States (unless otherwise indicated, for every kind of regional protection available): ARIPO (BW, GH, GM, KE, LS, MW, MZ, NA, SD, SL, SZ, TZ, UG, ZM, ZW), Eurasian (AM, AZ, BY, KG, KZ, MD, RU, TJ, TM), European (AT, BE, BG, CH, CY, CZ, DE, DK, EE, ES, FI, FR, GB, GR, HU, IE, IS, IT, LT, LU, MC, NL, PL, PT, RO, SE, SI, SK, TR), OAPI (BF, BJ, CF, CG, CI, CM, GA, GN, GQ, GW, ML, MR, NE, SN, TD, TG).

(71) Applicant (for all designated States except US): USGI MEDICAL INC. [US/US]; 1140 Calle Cordillera, San Clemente, CA 92673 (US).

(72) Inventors; and

(75) Inventors/Applicants (for US only): SAADAT, Vahid [US/US]; 12679 Kane Drive, Saratoga, CA 95070 (US). COX, John, A. [GB/US]; 2126 Cross Creek Road, Muncie, PA 18062 (US). ROTHE, Chris, A. [US/US]; 1593 Sabina Way, San Jose, CA 95118 (US).

Published:

— without international search report and to be republished upon receipt of that report

[Continued on next page]

(54) Title: METHODS AND APPARATUS FOR OBTAINING ENDOLUMINAL ACCESS

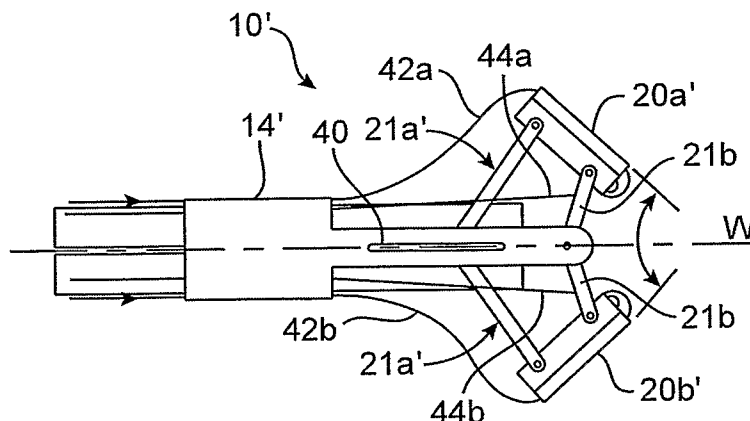

(57) Abstract: The present invention provides methods and apparatus for obtaining endoluminal access. An elongate body is configured for insertion within a body lumen, conduit, organ, orifice, passageway or cavity, the elongate body having a working axis and a distal region, and an articulating element disposed near the distal region, the articulating element configured to articulate off-axis from the working axis of the elongate body. The elongate may achieve access in an endoluminal or a laparoscopic fashion. Methods of using the apparatus are also provided.

WO 2005/104927 A2



For two-letter codes and other abbreviations, refer to the "Guidance Notes on Codes and Abbreviations" appearing at the beginning of each regular issue of the PCT Gazette.

METHODS AND APPARATUS FOR OBTAINING ENDOLUMINAL ACCESS

BACKGROUND OF THE INVENTION

5 [0001] Field of the Invention. The present invention relates to methods and apparatus for obtaining endoluminal access. More particularly, the present invention relates to methods and apparatus for obtaining endoluminal access utilizing off-axis articulation.

[0002] Medical endoscopy entails the insertion of an elongate body into a body lumen, conduit, organ, orifice, passageway, etc. The elongate body typically has a longitudinal or
10 working axis and a distal region, and a visualization element disposed near the distal region in-line with the working axis. The visualization element may comprise an optical fiber that extends through the elongate body, or a video chip having an imaging sensor, the video chip coupled to or including a signal-processing unit that converts signals obtained by the imaging sensor into an image. The elongate body may also include a working lumen to facilitate
15 passage of diagnostic or therapeutic tools therethrough, or for injection of fluids or to draw suction.

[0003] The maximum delivery profile for a medical endoscope may be limited by the cross-sectional profile of the body lumen, conduit, organ, orifice, passageway, etc., in which the endoscope is disposed. At the same time, advances in therapeutic endoscopy have led to
20 an increase in the complexity of operations attempted with endoscopes, as well as the complexity of tools advanced through the working lumens of endoscopes. As tool complexity has increased, a need has arisen in the art for endoscopes having relatively small delivery profiles that allow access through small body lumens, but that have relatively large working lumens that enable passage of complex diagnostic or therapeutic tools. Furthermore,
25 as the complexity of operations attempted with endoscopes has increased, there has arisen a need for enhanced visualization platforms, including three-dimensional or stereoscopic visualization platforms.

[0004] As with endoscopy, ever more challenging procedures are being conducted utilizing laparoscopic techniques. Due to, among other factors, the profile of instruments necessary to
30 perform these procedures, as well as a need to provide both visualization and therapeutic

instruments, laparoscopic procedures commonly require multiple ports to obtain the necessary access. Multiple ports also may be required due to the limited surgical space accessible with current, substantially rigid straight-line laparoscopic instruments.

5 [0005] In view of the foregoing, it would be desirable to provide methods and apparatus for obtaining endoluminal access that facilitate introduction of the apparatus into relatively small body lumens, while providing for introduction of at least one relatively large tool, as compared to standard endoscopes or laparoscopes. It also would be desirable to provide methods and apparatus that facilitate single port laparoscopy.

BRIEF SUMMARY OF THE INVENTION

10 [0006] Endoluminal access that facilitates introduction of the apparatus into relatively small body lumens while providing for introduction of at least one relatively large tool, as compared to a standard endoscope or laparoscope, may be accomplished by providing an elongate body configured for insertion within a body lumen, conduit, organ, orifice, passageway, etc. The elongate body has a working or main longitudinal axis and a distal
15 region, and at least one articulating element disposed near or at the distal region. The articulating element generally is configured to articulate off-axis or out-of-line from the working axis of the elongate body such that the element (or elements) are extendable and retractable in a radial direction relative to the working axis. The element may comprise, for example, the distal region of a working lumen extending through the elongate body; a
20 visualization element, such as a fiber optic or video chip; a diagnostic or therapeutic tool; or an illumination element. Additional alternative articulating elements will be apparent to one of skill in the art.

[0007] The articulating elements may alternatively or additionally provide radially extendable platforms from which various tools may be advanced and/or therapies may be
25 conducted. This extendable platform may allow the user to deploy the elements once the apparatus has been desirably situated within the body giving the user a versatile platform from which to access a greater portion of the body lumen while maintaining a device having a relatively small delivery profile.

[0008] Advantageously, the articulating element provides the elongate body with a
30 collapsed delivery configuration and a radially expanded deployed configuration. The collapsed delivery profile may facilitate passage of the elongate body within small body

lumens, cavities, etc., while the expanded deployed profile may facilitate diagnosis or therapy via the elongate body once the elongate body is disposed within the body lumen. For example, off-axis articulation of the articulating element may expose distal openings of one or more working lumens extending through the elongate body.

5 [0009] With traditional endoscopes or laparoscopes, a maximum profile of the working lumen is constrained by geometry of the visualization element. Conversely, the apparatus described herein enables one or more visualization elements, working lumens, tools, illumination elements, etc., to be aligned with the working axis of the elongate body in the delivery configuration, and articulated out of alignment in the radially deployed
10 configuration, thereby significantly reducing geometric constraints. As will be apparent, the working lumen(s), tool(s), illumination elements and visualization element(s) optionally may be provided as part of multiple distinct devices. For example, a standard endoscope or laparoscope may be provided as a visualization element, while one or more working lumens may be disposed within an overtube or endoluminal tool deployment system (e.g., as
15 described in Applicant's co-pending U.S. patent application Serial No. 10/797,485, filed March 9, 2004, which is incorporated herein by reference in its entirety) disposed over the standard endoscope/laparoscope. Apparatus of the present invention additionally or alternatively may be advanced through a trocar or multi-lumen insert, as described, for example, in Applicant's co-pending U.S. patent application Serial No. 10/843,682, filed May
20 10, 2004, which is incorporated herein by reference in its entirety.

[0010] Optionally, multiple articulating elements may be provided near the distal region of the elongate body. When the multiple articulating elements comprise two or more visualization elements, stereoscopic visualization may be provided. When the multiple elements comprise multiple working lumens or tools, complex therapeutic or diagnostic
25 endoluminal procedures may be performed. Combinations of various articulating elements may be provided.

[0011] When used in conjunction with laparoscopic endoluminal access, off-axis articulating element(s) may facilitate achievement of complex diagnostic and/or therapeutic laparoscopic procedures through a single port or opening. Likewise, when utilized for
30 endoscopic endoluminal access, the articulating element(s) may facilitate otherwise unachievable endoscopic procedures. Thus, off-axis articulating element(s) may enable a transition of procedures currently performed in an open surgical fashion or via multiple

laparoscopic ports to less invasive endoscopic or laparoscopic techniques. It is expected that the element(s) also may facilitate novel procedures that may not be performed utilizing current methods and apparatus.

[0012] It should be understood that, in addition to obtaining endoluminal access, the apparatus and methods described herein also may be utilized to obtain access to non-luminal spaces, regions, or cavities within a patient, for example, to the patient's peritoneum.

BRIEF DESCRIPTION OF THE DRAWINGS

[0013] FIGS. 1A-1E are side and frontal views of one variation of the apparatus, illustratively showing the articulating elements in collapsed delivery configurations, partially articulated configurations and expanded deployed configurations;

[0014] FIG. 2 is a perspective view of the apparatus of FIG. 1C;

[0015] FIGS. 3A-3E are side and frontal views of an alternative variation of the apparatus of FIGS. 1A-1C; shown, respectively, in collapsed, partially articulated, and expanded configurations;

[0016] FIG. 4 is a perspective view of the apparatus of FIG. 3C;

[0017] FIG. 5 is a schematic side view, partially in cut-away section, of an alternative variation comprising articulation biasing;

[0018] FIG. 6 is a schematic side view of an alternative variation comprising an articulating element having a steerable shaft;

[0019] FIG. 7 is a schematic side view of an alternative variation of the apparatus of FIG. 6 comprising multiple articulating elements having steerable shafts;

[0020] FIGS. 8A and 8B are schematic side views of illustrative variations of atraumatic tips for use with the apparatus;

[0021] FIGS. 9A and 9B are schematic side and detail views, respectively, of a variation of the apparatus of FIGS. 1 and 2 comprising an illumination articulating element and a visualization articulating element;

[0022] FIG. 10 is a detail view of an articulating element featuring visualization, illumination and flushing features;

[0023] FIG. 11 is a schematic view of a liner for use with an elongate body, the liner adapted to carry control elements through the body;

[0024] FIG. 12 is a schematic view of an exemplary link of an elongate body having through-holes for passage of control elements;

5 [0025] FIGS. 13A-13C are side views, partially in section, of an exemplary endoluminal method and apparatus for obtaining endoluminal access for performing diagnostic and/or therapeutic procedures;

[0026] FIG. 14 is a schematic view of exemplary laparoscopic apparatus for obtaining endoluminal access;

10 [0027] FIGS. 15A and 15B are schematic views, partially in section, of an exemplary method of using the apparatus of FIG. 14 to obtain single port laparoscopic endoluminal access for performing diagnostic and/or therapeutic procedures; and

[0028] FIG. 16 is a schematic cut-away view of an exemplary method of using the apparatus of FIG. 14 to obtain single port peritoneal access for performing diagnostic and/or
15 therapeutic procedures.

DETAILED DESCRIPTION OF THE INVENTION

[0029] Endoluminal access may be achieved more effectively by utilizing off-axis articulation with an apparatus advanced within a body lumen, e.g., advanced endoluminally
20 or laparoscopically within the body lumen. As described herein, off-axis articulating elements may act as radially extendable platforms from which various tools may be advanced or therapies may be conducted. This extendable platform may allow the user to deploy the elements once the apparatus has been desirably situated within the body, thereby giving the user a versatile platform from which to access a greater portion of the body lumen while
25 maintaining a device having a relatively small delivery profile.

[0030] With reference to FIGS. 1 and 2, a first variation of the apparatus is shown. Apparatus **10** comprises elongate body **12** configured for insertion within a body lumen, conduit, organ, orifice or passageway, e.g., via laparoscopic or endoluminal techniques. Body **12** comprises working axis **W** and distal region **13**. The elongate body may, for
30 example, comprise a flexible, steerable, rigidizable and/or multi-segmented body, such as described in Applicant's co-pending U.S. patent application Serial No. 10/797,485, filed

March 9, 2004, which has been incorporated by reference above. Body **12** alternatively may be substantially rigid and/or straight-line, and may be configured for laparoscopic access to the body lumen, etc. As will be apparent, flexible, steerable and/or rigidizable instruments may be advanced laparoscopically or endoluminally. Laparoscopic surgical techniques are described, for example, in Applicant's co-pending U.S. patent application Serial No. 10/843,682, filed May 10, 2004, which has been incorporated by reference above.

[0001] Apparatus **10** also comprises at least one articulating element **20**, shown in this example as two elements **20a** and **20b** (collectively referred to as elements **20**), disposed near or at distal region **13** of body **12**. Elongate body **12** further comprises housing **14**, which may be slidably disposed over one or more working lumens **16**, illustratively shown as working lumens **16a** and **16b**. Articulating elements **20** may be pivotally coupled to housing **14** by linkages **21a** and **21b**, which extend between hinges **22a** and **22b** of elements **20a** and **20b** and hinges **15a** and **15b**, respectively, of housing **14**. Push/pull members **24a** and **24b** also may be provided to actuate articulating elements **20a** and **20b**, respectively, between the collapsed profile and radially extended profile.

[0002] Members **24a** and **24b** may extend along elongate body **12**, for example, between housing **14** and lumens **16**, to a proximal region of the elongate body (not shown) for manipulation by a medical practitioner. The members may be coupled to one another for coordinated actuation of articulating elements **20**, or may be decoupled for independent actuation. Furthermore, the members may comprise cables or coils, as described hereinafter, adapted to convey control elements between the articulating elements and the elongate body.

[0003] As seen in FIGS. 1 and 2, articulating elements **20** are configured to articulate off-axis or out-of-line from working axis **W** of elongate body **12**. FIG. 1A shows articulating elements **20** in a collapsed delivery configuration having a reduced delivery profile suited for delivery within a body orifice, lumen, cavity, etc. FIG. 1B shows articulating elements **20** in a partially articulated configuration. FIGS. 1C and 2 show the articulating elements fully articulated to a deployed configuration of expanded profile.

[0004] Articulating elements **20** may be articulated from the reduced profile of FIGS. 1A and 1D to the expanded profile of FIGS. 1C and 1E, by retracting members **24** relative to housing **14**. The articulating elements may be articulated back to the collapsed profile, as desired, by advancing members **24** relative to housing **14**. As will be apparent, elements **20**

alternatively may be articulated by advancing or retracting housing 14 relative to members 24.

[0005] As seen in FIGS. 1C and 2, articulation of elements 20 to the expanded deployed configuration advantageously exposes distal openings 17a and 17b of working lumens 16a and 16b, respectively. In the delivery configuration of FIG. 1A, the lumens and articulating elements are aligned with working axis W of elongate body 12. Such alignment reduces the delivery profile of apparatus 10, but also causes articulating elements 20 to be disposed in-line with lumens 16, thereby blocking distal openings 17 of the lumens.

[0006] Articulating elements 20 off-axis and out of alignment with working axis W exposes distal openings 17 of lumens 16. Once exposed, lumens 16 may be used for passage of diagnostic or therapeutic tools from the proximal to the distal region of apparatus 10, as well as to draw suction, inject fluids, etc. By providing apparatus 10 with elements that articulate, lumens 16 may be provided with larger cross-sectional profiles than otherwise would be possible for a given delivery profile, as compared to apparatus having needed elements that cannot articulate.

[0007] Each articulating element 20 may comprise, for example, the distal region of a working lumen extending through elongate body 12. Alternatively, each articulating element may comprise a visualization element, such as a fiber optic or video chip. As yet another alternative, each articulating element may comprise a diagnostic or therapeutic tool, or an illumination element. Additional alternative articulating elements will be apparent.

[0008] In FIGS. 1 and 2, articulating elements 20 illustratively comprise visualization elements 30a and 30b. Elements 30 may comprise illumination sources 32a and 32b, as well as optics 34a and 34b. Optional illumination sources 32 may be used to provide light for imaging with elements 30, while optics 34 may, for example, comprise lenses, filters, etc. The optics may be coupled to one or more optical fibers and/or video chips that transmit visual information to a proximal region of apparatus 10. Optional flushing elements 35 also may be provided. Control elements for visualization elements 30, such as electrical wires, flushing lumens, etc., may run within or along push/pull members 24.

[0009] When video chips having imaging sensors are coupled to optics 34, the chips may be adapted to receive, as well as to transmit and/or signal process, visual information. Illustrative imaging sensors that may be used as part of visualization elements 30 include, but are not limited to, charge coupled device ("CCD") image sensors, complementary metal

oxide semiconductor (“CMOS”) image sensors, multi-layer solid state image sensors, direct image sensors, and combinations thereof. The video chips may wirelessly transmit signals to a processing and/or display unit, or one or more wires may extend along the length of the elongate body to carry such signals.

5 [0010] Since apparatus 10 has two articulating visualization elements 30, the apparatus 10 is adapted to provide stereoscopic or 3-dimensional visualization. Stereoscopic visualization may be displayed to a medical practitioner, for example, via a viewfinder disposed in front of the practitioner’s eyes or via a standard monitor. A depth of field, a focal point or depth, and/or a field of view of stereoscopic images produced with visualization elements 30 may be
10 altered, for example, by changing a degree of articulation of elements 30, by varying parameters of optics 34, via digital signal processing techniques, etc.

[0011] Referring now to FIGS. 3 and 4, an alternative variation of apparatus 10 is described. Apparatus 10’ comprises housing 14’ having at least one slot 40. Linkages 21a’ extend between hinges 22a of elements 20’ and slot 40 of housing 14’. In this variation,
15 linkages 21a’ are longer than more distal linkages 21b, and are slidably disposed within slot 40 of the housing. Apparatus 10’ further comprises proximal push/pull members 42a and 42b coupled to the proximal regions of articulating elements 20a and 20b, respectively, as well as distal push/pull members 44a and 44b coupled to the distal regions of elements 20.

[0012] As seen in FIGS. 3A-3E, actuation of articulating elements 20a’ and 20b’ may be
20 achieved by coordinated movements of proximal members 42a and 42b, distal members 44a and 44b and housing 14’. In FIGS. 3A and 3D, apparatus 10’ is disposed in the collapsed delivery configuration suitable for advancement within a body lumen. In FIG. 3B, members 42a and 42b, as well as members 44a and 44b, have been retracted relative to housing 14’. This causes long linkages 21a’ to articulate about hinges 22a of elements 20’ and slide
25 proximally within slot 40 of housing 14’, while linkages 21b articulate about hinges 15b and 22b. Elements 20a’ and 20b’ articulate out of alignment and off-axis from working axis W of elongate body 12, thereby exposing distal openings 17a and 17b of lumens 16a and 16b.

[0013] As seen in FIGS. 3C, 3E, and 4, subsequent advancement of proximal members 42a and 42b relative to housing 14’ and distal members 44a and 44b causes long linkages 21a’ to
30 slide distally within slot 40 and articulate about hinges 22a. Such movement causes the distal regions of elements 20’ to articulate inwards relative to the proximal regions of the elements,

thereby changing the relative angle between elements **20a'** and **20b'**. As will be apparent, elements **20a'** and **20b'** may be articulated in either a coordinated fashion or individually.

[0014] When elements **20a'** and **20b'** comprise visualization elements (optionally used in a stereoscopic fashion), relative angulation of the elements may be used to dynamically alter a focal point or depth, a depth of field and/or a field of view provided by the elements. When the elements comprise tools (e.g. grasping tool arms, cutting tools, plicating tools, affixing tools, etc.) or lumens, the tools or lumens may be angled for better positioning of the tools/lumens. When the elements comprise illumination elements, angling or angulation of the elements may better light a region of interest. As will be apparent, any combination of various articulating and/or angulate-able elements **20** may be provided, including combinations of visualization elements, illumination elements, tools, lumens, etc.

[0015] Referring now to FIG. 5, an alternative variation is described comprising articulation biasing. Apparatus **50** comprises elongate body **52** having working axis **W**, distal region **53**, working lumen **54**, control lumen **56** and ramp **58**. Apparatus **50** may further comprise articulating element **60** disposed near or at distal region **53** of body **52**. Articulating element **60** is coupled to elongate body **52** by proximal linkage **62** and torsion spring **64**. Linkage **62** extends between hinge **63** of articulating element **60** and control rod **59** disposed within control lumen **56** of body **52**. Torsion spring **64** extends between hinge **65** of the articulating element and hinge **55** of the elongate body. Torsion spring **64** provides element **60** with articulation biasing. In other variations, other biasing elements aside from torsion springs may be utilized.

[0016] As seen in dotted profile in FIG. 5, advancement of control rod **59** relative to elongate body **52** advances linkage **62** along ramp **58** and articulates element **60**, thereby exposing the distal end of lumen **54**. Torsion spring **64** has a natural tendency to push element **60** off-axis and biases the element to the articulated position. Once element **60** has 'sprung-up' to the articulated position, further advancement of rod **59** controls the angle θ of element **60** relative to elongate body **52**. Retraction of rod **59** may overcome the articulation biasing of spring **64** and return apparatus **50** to the collapsed delivery configuration. The spring constant of torsion spring **64** may be specified to control a degree of articulation biasing provided by the spring.

[0017] Referring now to FIG. 6, another variation is described wherein the articulating element comprises a steerable shaft. Apparatus **70** comprises elongate body **72** having

working axis **W**, distal region **73** and lumen **74**. Apparatus **70** further comprises articulating element **80** disposed near distal region **73** of elongate body **72**. Element **80** is coupled to the elongate body by previously-described linkages **21** disposed between hinges **15** and **22**.

[0018] Articulating element **80** comprises steerable shaft **82**. Shaft **82** may be passively articulate-able or, alternatively, may be actively controllable. Any number of conventional methods may be utilized to articulate the shape and configuration of shaft **82**. In FIG. 6, shaft **82** illustratively may, for example, be steerable in any number of directions. In this variation, shaft **82** may be steerable in at least four directions, e.g., via four control wires routed through or along cable **84** and elongate body **72** to a proximal region of apparatus **70** for manipulation by a medical practitioner. Cable **84** may also be used to articulate element **80**. As discussed hereinbelow with respect to FIGS. 11 and 12, proximal of cable **84**, the control wires for steerable shaft **82** preferably are routed through or along body **72** in spaces that would not be usable as working lumens or for tool insertion.

[0019] During delivery, articulating element **80** and steerable shaft **82** preferably are aligned with working axis **W** of elongate body **72**. Advantageously, the ability to articulate element **80** off-axis post-delivery allows apparatus **70** to have both a large working lumen **74** and a small collapsed delivery profile. Furthermore, steerable shaft **82** gives the apparatus an off-axis platform with added functionality for performing complex procedures. The steering capability of shaft **82** may be used to steer therapeutic or diagnostic tools, and/or for illumination, visualization, fluid flushing, suction, etc., into better position for conducting such procedures.

[0020] Various methods and apparatus for controlling elements used in conjunction with shaft **82** may be routed through cable **84** along with the control wires for shaft **82**. For example, when a visualization element is coupled to steerable shaft **82**, electrical wires may run through cable **84** for sending and/or receiving signals, power, etc., to/from the visualization element. In such a variation, the visualization element would allow direct visualization during insertion within a body lumen, while providing off-axis visualization and steering, as well as facilitating tool introduction, post-articulation. Alternatively or additionally, when a working lumen is disposed through steerable shaft **82**, cable **84** may comprise a lumen for connecting the shaft lumen to a lumen extending through elongate body **72** of apparatus **70**.

[0021] Referring now to FIG. 7, an alternative variation of apparatus 70 is described comprising multiple articulating elements having steerable shafts. Apparatus 70' comprises first articulating element 80a and second articulating element 80b. Elements 80 comprise first steerable shaft 82a and second steerable shaft 82b, respectively. Lumens 74a and 74b extend through elongate body 72' and are exposed upon articulation of elements 80a and 80b, respectively. As will be apparent, a single lumen or more than two lumens alternatively may be provided. Likewise, more than two articulating elements and/or steerable shafts optionally may be provided.

[0022] In FIG. 7, first steerable shaft 82a illustratively is shown with working lumen 86 that extends through the shaft, as well as through cable 84a and elongate body 72'. Exemplary grasper tool 90 is shown advanced through lumen 86. Second steerable shaft 82b illustratively is shown with visualization element 88 coupled to an end thereof. Electrical wires, e.g., for powering and transmitting signals to/from the visualization element, are disposed within cable 84b. As will be apparent, steerable shafts 82 may be provided with additional or alternative capabilities.

[0023] With reference to FIGS. 8, illustrative embodiments of atraumatic tips for use with apparatus of the present invention are described. In FIG. 8A, apparatus 70 of FIG. 6 is shown with atraumatic tip 76. Tip 76 provides a smooth transition between elongate body 72 and articulating element 80 with steerable shaft 82. Tip 76 may, for example, comprise an inflatable balloon that may be inflated as shown during insertion and delivery of apparatus 70, then deflated prior to articulation of element 80 and off-axis steering of shaft 82, so as not to block or impede articulation or the distal opening of the lumen 74 post-articulation.

[0024] In FIG. 8B, apparatus 50 of FIG. 5 comprises alternative atraumatic tip 78 having cap 79, which optionally may be fabricated from rubber. As illustrated by the cut-away section in FIG. 8B, the cap may be U-shaped to both provide a smooth transition between elongate body 52 and articulating element 60 in the delivery configuration, as well as to ensure that the cap does not block or impede lumen 54 post-articulation.

[0025] With reference now to FIGS. 9, a variation of the apparatus of FIGS. 1 and 2 is described comprising an articulating illumination element and an articulating visualization element. In FIG. 9A, articulating element 20a of apparatus 10 comprises previously described visualization articulating element 30, while articulating element 20b comprises illumination articulating element 100. Control wires for both element 30 and element 100,

illustratively routed through coils or cables **84**, are proximally coupled to control/power unit **110**. As seen in FIG. 9B, illumination element **100** comprises at least one light emitting diode (“LED”) **102**, as well as optional sensor **104**. Other variations may utilize other types of lights or illumination methods, e.g., incandescent lights, fluorescent lights or chemicals, etc. Control unit **110** may coordinate signals from visualization element **30** and sensor **104** to appropriately set the white balance of visualization element **30**, as well as the intensity of light emitted from LEDs **102**, etc.

[0026] With reference to FIG. 10, a combination articulating element is described that provides illumination, visualization and fluid flushing. Articulating element **120** comprises visualization element **130** having lens **132** and video chip **134** with an image sensor, such as a CCD or CMOS image sensor. The video chip is coupled to power source **136**, as well as signal processing and/or display unit **138**.

[0027] Element **120** further comprises illumination element **140** for illuminating a region of interest to facilitate visualization with element **130**. Illumination element **140** comprises optical fibers **142**, which are illustratively disposed in a ring about lens **132**. Fibers **142** are coupled to light source **144**.

[0028] Element **120** also comprises flushing element **150** for cleaning lens **132** of visualization element **130**, as well as optical fibers **142** of illumination element **140**. Flushing element **150** comprises tube **152** having lumen **154** that distally terminates at side port **156** disposed adjacent to lens **132**. Tube **152** may be proximally coupled to fluid injection element **158**, which may, for example, comprise a syringe filled with saline.

[0029] Referring now to FIG. 11, a liner for use with an elongate body is described. Liner **160** comprises polymeric substrate **162** having control elements **164** embedded or disposed therein. Liner **160** may, for example, be disposed within the working lumen of an elongate body of the present invention, such as working lumen **16** of elongate body **12** of apparatus **10**. Polymeric substrate **162** may seal the lumen and preclude contact between the elongate body and bodily fluids. Furthermore, control elements **164** may extend between proximally-disposed control, power, injection, processing, etc., units and a distally-disposed cable that communicates with an articulating element of the present invention. The control elements may comprise, for example, tension wires, electrical wires, optical fibers, fluid transport tubes, etc. The elements may be slidable relative to substrate **162**, or may be fixed relative to the substrate. When the position of control elements **164** is fixed relative to the substrate,

substrate **162** and elements **164** may be coextruded to form liner **160**. It is expected that routing the control elements within a liner will save room, thereby allowing for a larger working lumen for a given delivery profile.

[0030] With reference to FIG. 12, alternative apparatus for routing control elements is described. FIG. 12 illustrates exemplary link **200** for an elongate body. A plurality of such links may be nested within one another to form the elongate body. Steerable and/or shape-lockable elongate bodies formed from a plurality of nested links have been described previously, for example, in Applicant's co-pending U.S. patent application Serial No. 10/797,485, filed March 9, 2004, which has been incorporated herein by reference. Link **200** comprises working lumen **202** and through-holes **204**. Control elements **162** may be routed through the through-holes. In FIG. 12, exemplary control element **162** is illustratively disposed within coil **206**. Coil **206** may protect the control element during bending of an elongate body formed from a plurality of links **200**. Furthermore, coil **206** may provide superior torqueability and/or pushability to such an elongate body.

[0031] One method for obtaining endoluminal access comprises advancing an elongate body or guide, as described above, into a body lumen or other cavity, e.g. advancing the elongate body or guide laparoscopically or endoluminally. The elongate body comprises an articulating element disposed near a distal region thereof, and the exemplary method further comprises articulating the articulating element from a position in-line with a working axis of the elongate body to a position out-of-line or off-axis from the working axis. Articulating the articulating element may expand the articulating element from a reduced delivery configuration to an expanded deployed configuration in a radially extended manner. Furthermore, articulating the element may expose the distal opening of a lumen through which a tool, fluid, suction, etc., may be advanced or withdrawn.

[0032] The method may further comprise imaging within the body lumen via an articulated visualization element. Such imaging optionally may be stereoscopic, and the depth of field, field of view, focal point or depth, etc., of such imaging may be altered. Additionally or alternatively, the method may comprise performing diagnostic or therapeutics actions via tools or instruments attached to, or advanced along, an articulated element. The method further may comprise repositioning the articulating element in-line with the working axis of the elongate body and manipulating or removing the elongate body from the body lumen, as

well as optionally re-articulating the element. The elongate body may be steered and/or rigidized while obtaining endoluminal access.

5 [0033] Referring now to FIGS. 13, an exemplary endoluminal method and apparatus for obtaining endoluminal access is described. In FIG. 13A, apparatus 10 of FIGS. 1 and 2 is shown with an exemplary elongate body 12 formed from a plurality of links 200 of FIG. 12. Articulating element(s) 20 are disposed at the end of elongate steerable and shape-lockable/rigidizable body 12. Apparatus 10 is advanced per-orally and endoluminally through the patient's esophagus E past gastroesophageal junction GE into stomach S with articulating elements 20 disposed in a low profile delivery configuration. Visualization
10 element 30 may, for example, be positioned on one or more of the articulating elements 20 to provide direct visualization during endoluminal positioning of apparatus 10, as well as to provide direct visualization of tools advanced through lumen(s) 16 of elongate body 12 of the apparatus post-articulation of element(s) 20.

15 [0034] As seen in FIG. 13B, body 12 may be steered, retroflexed, etc., into a desired configuration for diagnosis or treatment. Exemplary endoluminal treatments, such as gastric reduction and treatment of GERD, have been described previously, for example, in Applicant's co-pending U.S. patent applications Serial Nos. 10/734,562, filed December 12, 2003; and 10/841,233, filed May 7, 2004, both of which are incorporated herein by reference in their entireties. Once properly positioned, element(s) 20 may be articulated off-axis to
20 expose one or more lumens 16 through which additional tools or instruments, such as tissue plication assembly 210 and tissue manipulation assembly 220, may be advanced. As will be apparent, other tools also may be utilized, depending upon the desired diagnostic and/or therapeutic procedure to be performed upon the tissue. As seen in FIG. 13C, after completion of a diagnostic or therapeutic procedure; such as formation, approximation and securement of
25 anterior and posterior tissue folds F to partition stomach S; the apparatus may be returned to a low-profile configuration by retracting the tools or instruments back within lumen(s) 16 and articulating element(s) 20 back into alignment with the longitudinal axis of elongate body 12 of apparatus 10. Apparatus 10 then may be removed from the patient to complete the procedure.

30 [0035] With reference to FIGS. 14 and 15, an exemplary laparoscopic method and apparatus for obtaining endoluminal access is described. In FIGS. 14, apparatus 70 of FIG. 6 is shown with an exemplary elongate body 72 formed from a plurality of links 200 of FIG.

12. One or more lumens **74** extend through body **72**, and articulating element **80**, having four-way steerable shaft **82** and optional visualization element **30**, is disposed near distal region **73** of the elongate body. Illustrative control handle **230** is provided to manipulate apparatus **70**. Lumen **231** extends through the handle and communicates with lumen(s) **74** of elongate body **72**. Knob **232** of handle **230** may facilitate steering of elongate body **72**, while knob **234** may control off-axis articulation of element **80**, and knobs **236a** and **236b** (see FIG. 15B) may control four-way steering of shaft **82**. Knob **236a** may, for example, facilitate steering of shaft **82** along an axis perpendicular to a steering axis controllable via knob **236b**. Handle **230** further comprises shape-locking or rigidizing lever **238** for maintaining a configuration of elongate body **72**. Steering, off-axis articulation and and/or shape-locking of apparatus **70** with handle **230** preferably is achieved via tensioning wires that extend along elongate body **72** through through-holes **204** of links **200** (see FIG. 12).

[0036] Apparatus **70** may be used in conjunction with trocar assembly **250** to perform single-port laparoscopic procedures. Trocar assembly **250** may be any standard or customized trocar assembly and may comprise obturator **252** having sharpened tip **254**, as well as trocar **260** having lumen **261** with a universal or other fluid seal therein. Lumen **261** and the fluid seal are configured for passage of obturator **252** therethrough. The lumen and seal are also configured for passage of apparatus **70** or other apparatus therethrough.

[0037] Trocar **260** optionally may comprise member **264** for stabilizing the trocar against tissue, as described hereinafter. Member **264** optionally may be expandable and/or inflatable, and may be expandable from a low profile configuration, as shown in dotted profile in FIG. 14, to the illustrated expanded configuration. The optional low profile configuration may facilitate placement of member **264** across the wall of a body lumen or cavity.

[0038] Trocar **260** may comprise a substantially rigid tubular shaft, or may be flexible and passively or actively steerable, as illustrated in dotted profile in FIG. 14. When actively steerable, trocar **260** may, for example, be fabricated from a plurality of links **200** and manipulated via optional control handle **270**. Additional laparoscopic apparatus and methods, which may be utilized as desired in combination with apparatus of the present invention, are described in Applicant's co-pending U.S. patent application Serial No. 10/843,682, filed May 10, 2004, which has been incorporated herein by reference.

[0039] As seen in FIG. 15A, an incision may be formed through a patient's skin, and trocar **260**, having obturator **252** disposed therethrough, may be advanced through the incision

directly into stomach **S**, as shown, or into the peritoneal space. Treatment or diagnosis (e.g., obesity treatment, appendectomy, cholecystectomy or gall bladder removal, etc.) may be performed within the peritoneum (see FIG. 16), or trocar assembly **250** may be further advanced into a body lumen, such as the stomach. In FIG. 15A, sharpened tip **254** of obturator **252** pierces the wall of stomach **S**, and a distal region of trocar **260** is advanced within the stomach. Obturator **252** then may be removed from lumen **261** of trocar **260**, and member **264** optionally may be expanded. If the member is disposed within stomach **S**, trocar **260** may be retracted such that a position of the trocar is stabilized against the internal wall of the stomach. Alternatively, if the member is disposed exterior to the patient, as in FIG. 15A, the trocar may be advanced such that the position of the trocar is stabilized against the patient's skin or exterior. In FIGS. 15, although trocar **260** illustratively has been placed through the antrum of the patient's stomach, it should be understood that the trocar alternatively may be positioned at any other location, as desired.

[0040] As seen in FIG. 15B, once trocar **260** has been properly placed, apparatus **70** may be advanced through the trocar into stomach **S** with articulating element **80** disposed in a low profile delivery configuration. Elongate body **72** then may be steered into a desired configuration for diagnosis or treatment and optionally may be rigidized or shape-locked, e.g., via lever **238**, to maintain the desired configuration. Optional visualization element **30** coupled to articulating element **80** may facilitate steering of elongate body **72** into a desired configuration or position. Once apparatus **70** is properly positioned, element **80** may be articulated off-axis to expose one or more lumen(s) **74** through which additional tools or instruments, such as tissue plication assembly **210** and tissue manipulation assembly **220**, may be advanced.

[0041] Plication assembly **210** illustratively comprises elongate, flexible shaft **212** coupled to control handle **214** for operating the plication assembly. Likewise, manipulation assembly **220** illustratively comprises elongate, flexible shaft **222** coupled to control handle **224** for operating the manipulation assembly. As will be apparent, additional or alternative instruments, such as an endoscope or laparoscope may be utilized. Furthermore, the instruments optionally may be configured for passage through steerable shaft **82** of articulating element **80** to facilitate off-axis use of the instruments. In FIGS. 15, shaft **82** illustratively comprises visualization element **30**, and procedures performed with assemblies **210** and **220** may be monitored via the visualization element.

[0042] After completion of a diagnostic or therapeutic procedure, apparatus 70 may be returned to a flexible, low-profile configuration by releasing lever 238, retracting assemblies 210 and 220 within lumen(s) 74 and articulating element 80 back into alignment with the longitudinal axis of elongate body 72, as in FIG. 14. The apparatus then may be retrieved through trocar 260. Trocar 260 may be removed, and the punctures through the stomach wall and the patient's skin may be sutured closed. In this manner, the apparatus facilitates performance of complex endoluminal or peritoneal procedures through a single laparoscopic access port or trocar. The apparatus preferably comprises both visualization and other diagnostic and/or therapeutic tools. As will be apparent, additional laparoscopic ports optionally may be provided, as desired. Furthermore, instruments advanced through the patient's esophagus optionally may be used in conjunction with laparoscopic endoluminally placed instruments. Furtherstill, apparatus 70 may be advanced across the patient's skin, e.g., into the patient's peritoneum or stomach, without use of an intervening trocar.

[0043] With reference now to FIG. 16, an illustrative method of using the apparatus of FIG. 15 in the peritoneal cavity or space is described. Trocar 260 may be placed through the patient's skin and across the tissue wall within the patient, as described previously, and apparatus 70 may be advanced through the trocar into peritoneal cavity P. In FIG. 16, member 264 of trocar 260 illustratively also is disposed within the peritoneal cavity, and is expanded to stabilize the trocar against the interior wall of the cavity. Articulating element 80 then may be articulated off-axis, and instruments, such as tissue plication assembly 210 and tissue manipulation assembly 220, may be advanced through lumen(s) 74 of apparatus 70 and/or through shaft 82 of element 80 to perform a diagnostic and/or therapeutic procedure within the cavity. Articulating element 80 optionally may comprise visualization element 30 for monitoring procedures performed via apparatus 70. Diagnostic and/or therapeutic procedures may, for example, be performed on the patient's liver L, gall bladder G, stomach S, intestines I, appendix A, etc.

[0044] Appendectomy is an exemplary therapeutic procedure that may be performed within the peritoneal cavity. Such a procedure may, for example, proceed as follows. Access to peritoneal cavity P may be gained via an 18-20 mm dilated incision in the umbilicus, similar to a hassan entry. Apparatus 70 then may be introduced through a trocar, such as trocar 260 as in FIG. 16, or may be introduced bluntly through the incision in a rigid state, pre-shaped by the surgeon to allow it to be placed in the direction of the target area. A pneumoperitoneum may be established and maintained to the normal standards for

conventional laparoscopy, for example, via an insufflation channel extending through an insufflation lumen 74 of apparatus 70. Visualization element 30 may be connected to a light source and a video monitor exterior to the patient in order to establish visualization, and a proximal section of apparatus 70 optionally may be locked to a standard table-mounted clamp.

[0045] Next, apparatus 70 may be steered and re-positioned such that an inspection of the Cecum and appendix A can be completed. Element 80 is articulated off-axis to provide a “top down” view with visualization element 30, wherein the Appendix is centered in the field of view. An operating dissector and scissor are introduced, for example, through first and second lumens 74 of apparatus 70. Utilizing the dissector and scissors as necessary, appendix A is bluntly separated from any adherent omentum or adhesions and mobilized. Depending on positioning of the appendix relative to the cecum, further mobilization may be necessary.

[0046] A temporary clamp or suture may be introduced through a third lumen 74 of apparatus 70 and is placed across the appendiceal mesentery in the standard fashion. The appendiceal mesentery is then ligated and divided using, for example, cautery or ligating clips and scissors. Temporary clamps or sutures then may be placed at the base of the appendix if desired. Scissors are used to transect the base of appendix A flush with the clamp or suture. An anchor stitch may be placed to close the remnant base, or it may be left open and secured by inversion within the cecum. Further anchors may be placed to affect a purse string suture at the cecum and invert the stump. The area may be inspected for hemostasis and irrigated/suctioned in the standard fashion for laparoscopy.

[0047] Next, the dissector may be affixed to the tip of the appendix, element 80 may be articulated back in-line with the longitudinal axis of elongate body 72, and apparatus 70 may be withdrawn through the umbilicus. Alternatively, an anchor may be placed through the tip of the appendix and the suture end may be grasped via the dissector. Apparatus 70 then may be removed gently from the peritoneal cavity, and the end of appendix A may be pulled through the incision until it can be grasped using a standard surgical clamp. The appendix is delivered through the incision in the standard fashion, and the incision is closed with sutures. It should be understood that the preceding method of removing a patient’s appendix utilizing apparatus 70 is provided for the purposes of illustration, and variations or modifications to the method within the scope of the present invention will be apparent to those of skill in the art.

[0048] Cholecystectomy is another exemplary therapeutic procedure that may be performed within peritoneal cavity **P**. Access to the peritoneal cavity again may be gained via an 18-20 mm dilated incision in the umbilicus, similar to a hassan entry. Apparatus **70** may be introduced through a trocar or may be introduced bluntly through the incision in a rigid state, pre-shaped by the surgeon to allow it to be placed in the direction of the target area. A pneumoperitoneum may be established and maintained to the normal standards for conventional laparoscopy, for example, via an insufflation channel extending through an insufflation lumen **74** of apparatus **70**. Visualization element **30** may be connected to a light source and a video monitor exterior to the patient in order to establish visualization, and a proximal section of apparatus **70** optionally may be locked to a standard table-mounted clamp.

[0049] Apparatus **70** is steered and positioned such that an inspection of the upper right quadrant can be completed via visualization element **30** of articulating element **80**. Element **80** then may be articulated off-axis to provide a "top down" view of the fundus of gallbladder **G**. If the gallbladder cannot be seen, an operating dissector and scissor or electrosurgical hook may be extended through lumen(s) **74** of apparatus **70**, and any adhesions may be removed.

[0050] A retracting grasper may be inserted through a lumen **74** of apparatus **70** and firmly affixed and locked to the fundus of gallbladder **G**. The gallbladder then may be exposed via anterior and lateral traction, for example, in the manner of conventional laparoscopy. Utilizing scissors advanced through apparatus **70** to create an incision in the cystic duct and a self-sealing catheter, an intraoperative cholangiogram may be performed.

[0051] The cystic duct may be isolated using the dissector and an electrosurgical hook, and the cystic artery then may be skeletonized and isolated using a similar technique. The location of the common duct and any unusual arterial branches may be visually verified. The electrosurgical hook may be withdrawn, and ligating ties or clips may be placed on the duct and artery, thereby leaving double closure if desired on each patient side. Scissors may be introduced through apparatus **70** and used to transect the artery and duct, thereby completely mobilizing the gallbladder infundibulum.

[0052] The retraction grasper optionally may be maintained at the fundus or may be repositioned centrally along the gallbladder as desired. Utilizing cautery scissors or hook introduced through apparatus **70**, as well as the operating dissector for additional traction and

dissection, the gallbladder serosa is scored, and the fundus is mobilized in the manner of conventional laparoscopy. The gallbladder bed is inspected and any bleeding areas are cauterized. Irrigation may be used to clean the area and facilitate inspection. Once the gallbladder is completely excised, the grasper may be repositioned for easy removal of the specimen. Element **80** then may be articulated back in-line with the longitudinal axis of elongate body **72**, and apparatus **70** may be slowly straightened and withdrawn, pulling gallbladder **G** along with the locked grasper. Once the gallbladder is visible through the incision, a clamp replaces the grasper, the gallbladder is removed through the umbilicus and the incision is closed.

5
10 [0053] It should be understood that the preceding method for performing cholecystectomy utilizing apparatus **70** is provided for the purposes of illustration, and variations or modifications to the method within the scope of the present invention will be apparent to those of skill in the art. Furthermore, alternative methods and procedures utilizing apparatus **70** within peritoneal cavity **P**, stomach **S**, or any other region of a patient's body will be
15 apparent to those of skill in the art.

[0054] Although various illustrative embodiments are described above, it will be evident to one skilled in the art that various changes and modifications are within the scope of the invention. It is intended in the appended claims to cover all such changes and modifications that fall within the true spirit and scope of the invention.

WHAT IS CLAIMED IS:

- 1 1. Apparatus for obtaining endoluminal access, the apparatus comprising:
2 an elongate body having a working axis and a distal region, the elongate body
3 configured for insertion within a body lumen; and
4 at least one articulating element disposed near or at the distal region of the
5 elongate body,
6 wherein the articulating element is configured to articulate off-axis from the
7 working axis of the elongate body.
- 1 2. The apparatus of claim 1, wherein the articulating element comprises a
2 visualization element configured to image within a body lumen.
- 1 3. The apparatus of claim 1, wherein the articulating element comprises
2 the distal region of a lumen extending through the elongate body.
- 1 4. The apparatus of claim 1, wherein the apparatus has a delivery
2 configuration in which the articulating element is aligned with or adjacent to the working axis
3 of the elongate body, and a deployed configuration wherein the articulating element is
4 articulated off-axis from the working axis of the elongate body.
- 1 5. The apparatus of claim 1, wherein the articulating element further
2 comprises at least two articulating elements.
- 1 6. The apparatus of claim 5, wherein the at least two articulating elements
2 are configured for independent off-axis articulation.
- 1 7. The apparatus of claim 5, wherein the at least two articulating elements
2 are configured for coordinated off-axis articulation.
- 1 8. The apparatus of claim 3, wherein the at least two articulating elements
2 comprise at least two visualization elements configured to provide stereoscopic visualization.
- 1 9. The apparatus of claim 8, wherein a focal depth of the at least two
2 visualization elements may be altered by altering a relative angle between the at least two
3 visualization elements.

1 10. The apparatus of claim 2, wherein the visualization element comprises
2 a fiber optic visualization element.

1 11. The apparatus of claim 2, wherein the visualization element comprises
2 a video chip coupled to a signal-processing unit.

1 12. The apparatus of claim 11, wherein the video chip comprises an image
2 sensor.

1 13. The apparatus of claim 12, wherein the image sensor is chosen from
2 the group consisting of charge coupled device (CCD) image sensors, complementary metal
3 oxide semiconductor (CMOS) image sensors, multi-layer solid state image sensors, direct
4 image sensors, and combinations thereof.

1 14. The apparatus of claim 2, wherein the visualization element is coupled
2 to a display unit.

1 15. The apparatus of claim 1, wherein the elongate body further defines a
2 lumen.

1 16. The apparatus of claim 15, wherein off-axis articulation of the
2 articulating element is configured to expose a distal opening of the lumen.

1 17. The apparatus of claim 4, wherein the elongate body further defines a
2 lumen, and wherein a distal opening of the lumen is exposed in the deployed configuration.

1 18. The apparatus of claim 17, wherein the distal opening is covered by the
2 articulating element in the delivery configuration.

1 19. The apparatus of claim 1 further comprising a visualization element.

1 20. The apparatus of claim 19, wherein off-axis articulation of the
2 articulating element is configured to expose the visualization element.

1 21. The apparatus of claim 2 further comprising a light source configured
2 to illuminate the interior of the body lumen and facilitate visualization with the visualization
3 element.

1 22. The apparatus of claim 15 wherein the elongate body further defines
2 multiple lumens.

1 23. The apparatus of claim 1 further comprising a housing configured to
2 couple the articulating element to the elongate body and to facilitate articulation of the
3 articulating element.

1 24. The apparatus of claim 23, wherein the housing comprises at least one
2 linkage for articulating the articulating element.

1 25. The apparatus of claim 2, wherein the visualization element comprises
2 optics.

1 26. The apparatus of claim 1, wherein the elongate body is steerable.

1 27. The apparatus of claim 1, wherein the elongate body is rigidizable.

1 28. The apparatus of claim 1, wherein the articulating element further
2 comprises a steerable shaft.

1 29. The apparatus of claim 1, wherein the articulating element further
2 comprises a diagnostic or therapeutic tool.

1 30. The apparatus of claim 1 further comprising an atraumatic tip.

1 31. A method for obtaining endoluminal access, the method comprising:
2 advancing an elongate body having an articulatable element disposed near or
3 at a distal region thereof into a body lumen; and
4 articulating the articulatable element from a position in-line with or adjacent to
5 a working axis of the elongate body to a position out-of-line with the working axis.

1 32. The method of claim 31, further comprising imaging within the body
2 lumen with a visualization element disposed within or upon the articulatable element.

1 33. The method of claim 32, wherein imaging further comprises imaging
2 stereoscopically.

1 34. The method of claim 31, wherein articulating the articulatable element
2 comprises exposing a distal opening of at least one lumen defined within the elongate body.

1 35. The method of claim 34 further comprising advancing a tool through
2 the lumen.

1 36. The method of claim 34 further comprising injecting or withdrawing a
2 fluid through the lumen.

1 37. The method of claim 31, wherein articulating the articulatable element
2 further comprises expanding the articulatable element from a reduced delivery configuration
3 to an expanded deployed configuration.

1 38. The method of claim 31 further comprising repositioning the
2 articulating element in-line with or adjacent to the working axis of the elongate body.

1 39. The method of claim 38 further comprising removing the elongate
2 body from the body lumen.

1 40. The method of claim 38 further comprising manipulating the elongate
2 body and re-articulating the articulatable element out-of-line with the working axis.

1 41. The method of claim 33, further comprising altering a focal depth
2 during stereoscopic imaging.

1 42. The method of claim 31 further comprising steering the elongate body
2 within the body lumen.

1 43. The method of claim 31 further comprising rigidizing the elongate
2 body within the body lumen.

1 44. Apparatus for obtaining endoluminal access, the apparatus comprising:
2 a steerable guide having a working axis, at least one lumen and a distal region,
3 the guide configured for insertion within the body lumen; and
4 an articulating element disposed near the distal region of the steerable guide,
5 wherein the articulating element is configured to articulate off-axis from the
6 working axis of the elongate body.

1 45. The apparatus of claim 44, wherein the steerable guide is configured to
2 steer the articulating element within the body lumen to facilitate access to regions of interest
3 within the body lumen.

1 46. The apparatus of claim 44, wherein the articulating element comprises
2 a distal region of the lumen.

1 47. The apparatus of claim 44, wherein the articulating element comprises
2 a visualization element.

1 48. The apparatus of claim 44, wherein the articulating element further
2 comprises a steerable shaft.

1 49. The apparatus of claim 44, wherein the articulating element comprises
2 a diagnostic or therapeutic tool.

1 50. The apparatus of claim 44 further comprising an atraumatic tip.

1 51. Apparatus for obtaining laparoscopic endoluminal access, the
2 apparatus comprising:
3 a trocar having a lumen, the trocar configured for placement across a wall of a
4 body lumen;
5 an elongate body adapted for insertion through the trocar lumen, the elongate
6 body having a longitudinal axis and a distal region; and
7 at least one articulating element disposed near or at the distal region, the at
8 least one articulating element being configured to articulate off-axis relative to the
9 longitudinal axis of the elongate body.

1 52. The apparatus of claim 51, wherein the articulating element comprises
2 a visualization element configured to image within a body lumen.

1 53. The apparatus of claim 51, wherein the apparatus has a delivery
2 configuration in which the articulating element is aligned with or adjacent to the longitudinal
3 axis of the elongate body, and a deployed configuration wherein the articulating element is
4 articulated off-axis from the longitudinal axis of the elongate body, and

5 wherein the elongate body is configured for insertion through the lumen of the
6 trocar when the apparatus is in the delivery configuration.

1 54. The apparatus of claim 51, wherein the articulating element further
2 comprises at least two articulating elements.

1 55. The apparatus of claim 54, wherein the at least two articulating
2 elements are configured for independent off-axis articulation.

1 56. The apparatus of claim 54, wherein the at least two articulating
2 elements are configured for coordinated off-axis articulation.

1 57. The apparatus of claim 52, wherein the visualization element
2 comprises a fiber optic visualization element.

1 58. The apparatus of claim 52, wherein the visualization element
2 comprises a video chip coupled to a signal-processing unit.

1 59. The apparatus of claim 51, wherein the elongate body further defines a
2 lumen.

1 60. The apparatus of claim 59, wherein off-axis articulation of the
2 articulating element is configured to expose a distal opening of the elongate body lumen.

1 61. The apparatus of claim 51 further comprising a visualization element.

1 62. The apparatus of claim 61 further comprising a light source for
2 illuminating an interior of the body lumen to facilitate visualization with the visualization
3 element.

1 63. The apparatus of claim 51 further comprising a housing configured to
2 couple the articulating element to the elongate body and to facilitate articulation of the
3 articulating element.

1 64. The apparatus of claim 51, wherein the elongate body is steerable.

1 65. The apparatus of claim 51, wherein the elongate body is rigidizable.

1 66. The apparatus of claim 51, wherein the articulating element further
2 comprises a diagnostic or therapeutic tool.

1 67. A method for obtaining access to a body lumen or body cavity, the
2 method comprising:

3 placing a trocar across a wall of the body lumen or body cavity;

4 advancing an elongate body having an articulatable element disposed near or
5 at a distal region thereof through the trocar and into the body lumen or body cavity; and

6 articulating the articulatable element from a position in-line with or adjacent to
7 a longitudinal axis of the elongate body to a position off-axis relative to the longitudinal axis.

1 68. The method of claim 67, further comprising imaging within the body
2 lumen or body cavity with a visualization element disposed within or upon the articulatable
3 element.

1 69. The method of claim 67, wherein articulating the articulatable element
2 comprises exposing a distal opening of at least one lumen defined within the elongate body.

1 70. The method of claim 69 further comprising advancing a tool through
2 the lumen of the elongate body.

1 71. The method of claim 67, wherein articulating the articulatable element
2 further comprises expanding the articulatable element from a reduced delivery configuration
3 to an expanded deployed configuration.

1 72. The method of claim 67 further comprising steering the elongate body
2 within the body lumen or body cavity.

1 73. The method of claim 67 further comprising rigidizing the elongate
2 body within the body lumen or body cavity.

1 74. The method of claim 67, wherein the body lumen comprises a
2 stomach.

1 75. The method of claim 67, wherein the body cavity comprises a
2 peritoneal space.

1 76. A method for obtaining access to a body lumen or body cavity, the
2 method comprising:

3 advancing an elongate body into the body lumen or cavity through a single
4 opening; and

5 articulating a platform coupled to the elongate body and disposed within the
6 body lumen or cavity from a position in-line with or adjacent to a longitudinal axis of the
7 elongate body to a position off-axis relative to the longitudinal axis.

1 77. The method of claim 76, further comprising imaging within the body
2 lumen or body cavity with a visualization element disposed within or upon the articulated
3 platform.

1 78. The method of claim 76 further comprising advancing a tool through at
2 least one lumen defined within the elongate body.

1 79. The method of claim 76, wherein the body lumen comprises a
2 stomach.

1 80. The method of claim 79 further comprising performing endoluminal
2 gastric reduction or partitioning within the stomach via tools advanced through the articulated
3 platform or through a lumen extending through the elongate body.

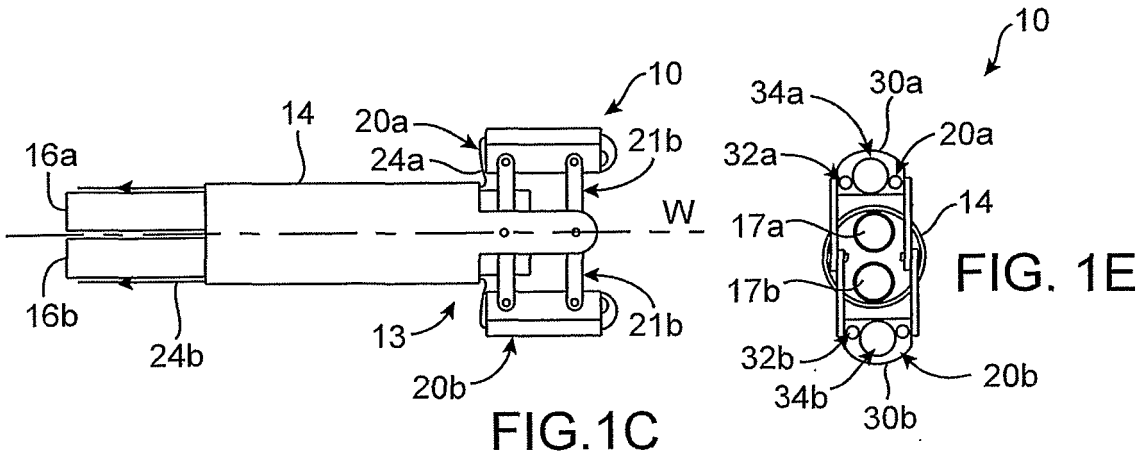
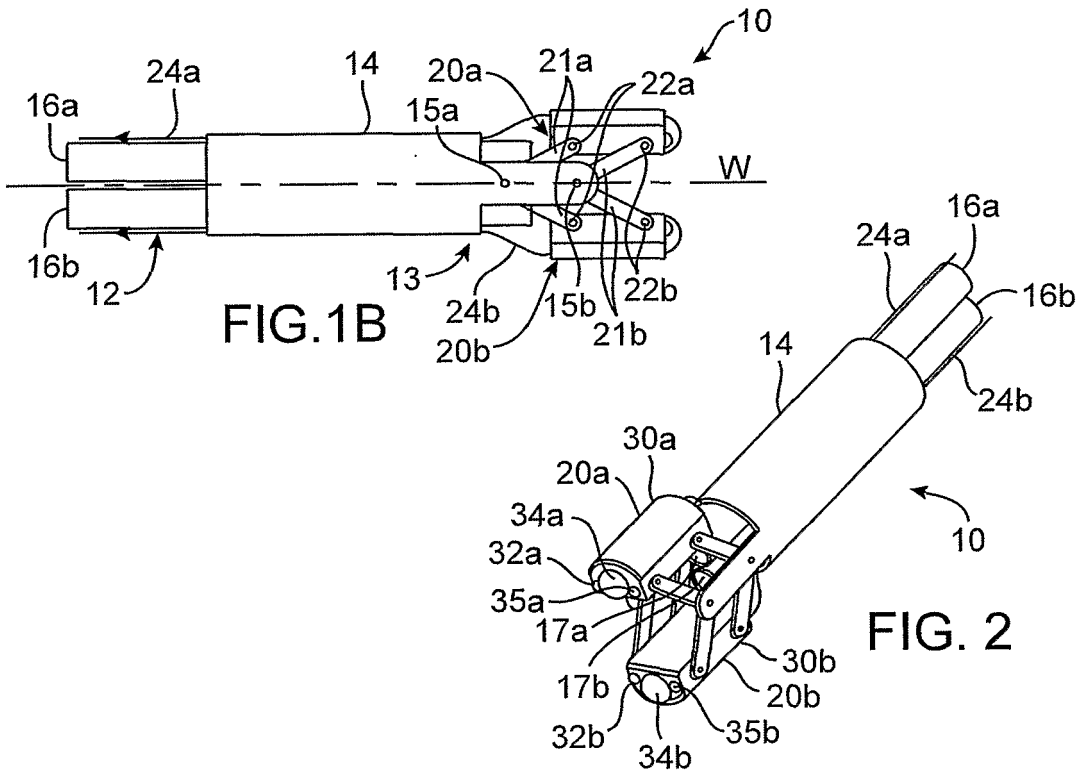
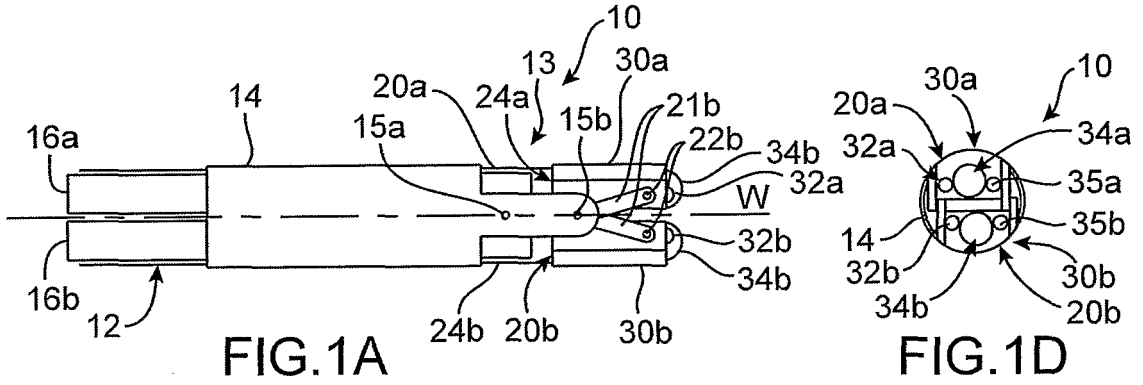

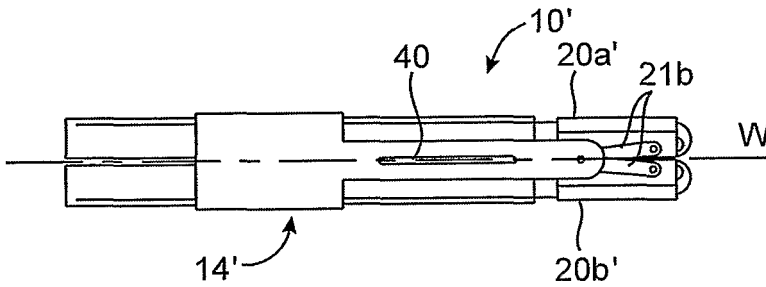

FIG. 3A

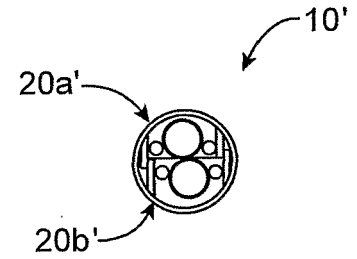

FIG. 3D

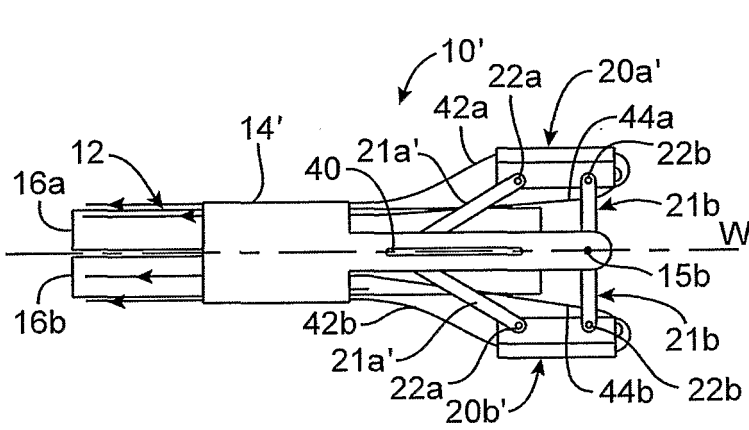

FIG. 3B

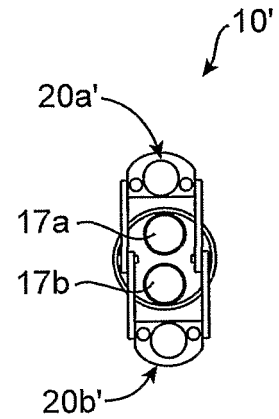

FIG. 3E

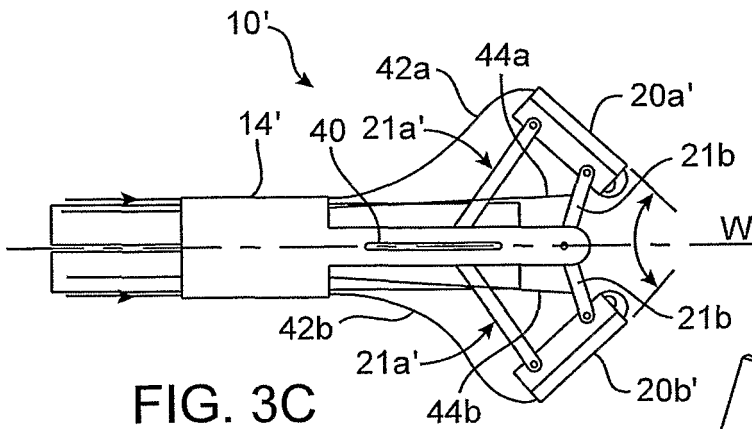

FIG. 3C

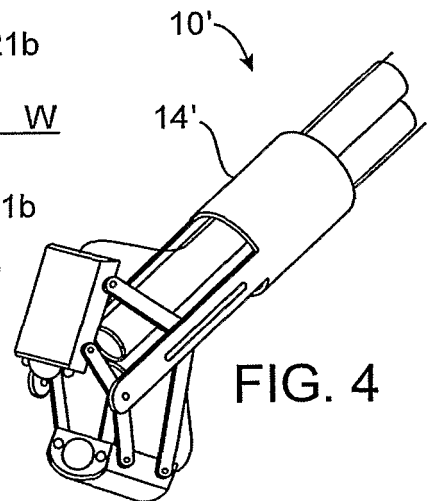

FIG. 4

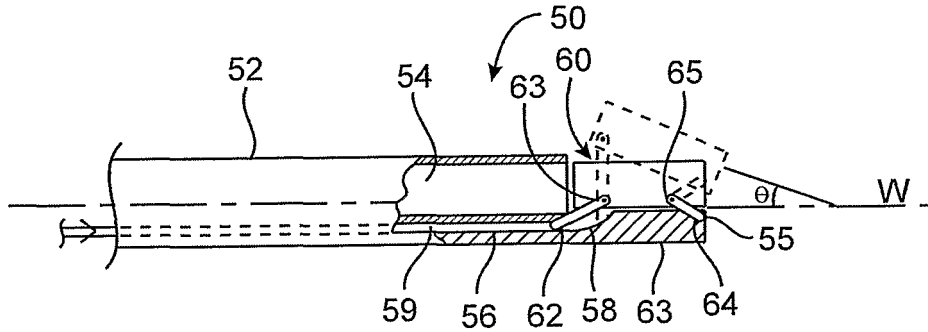

FIG. 5

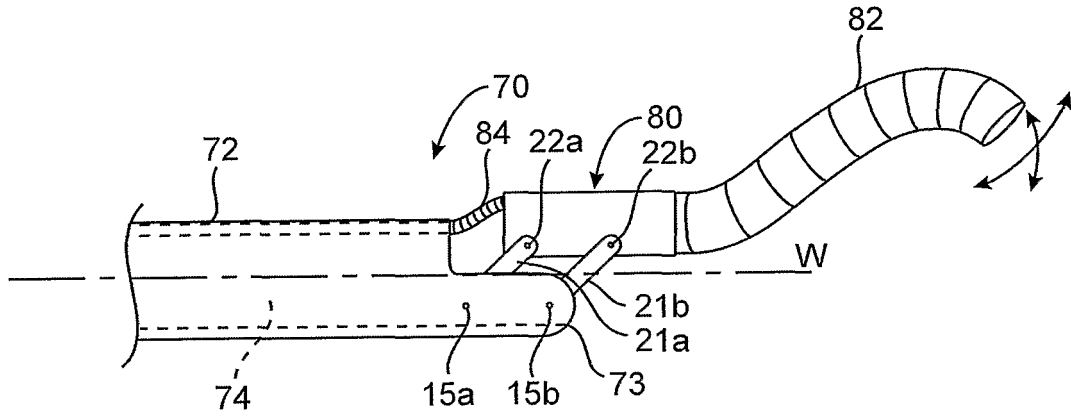

FIG. 6

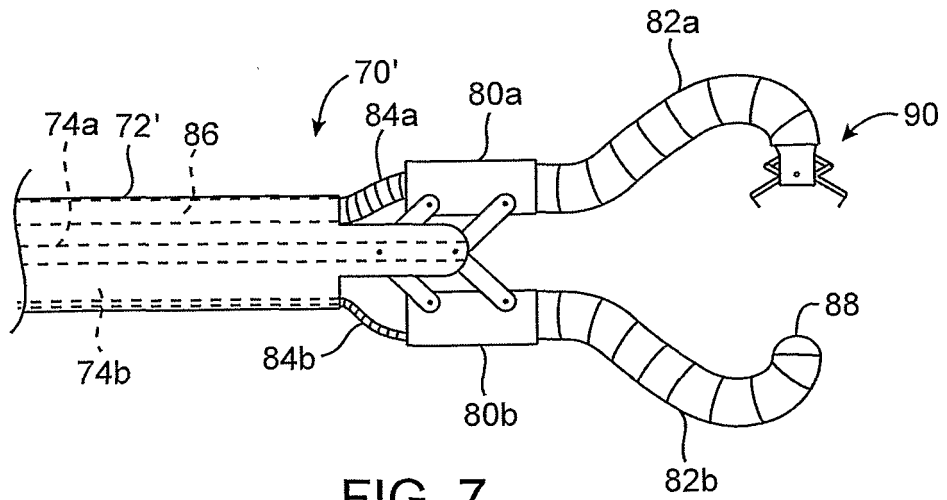

FIG. 7

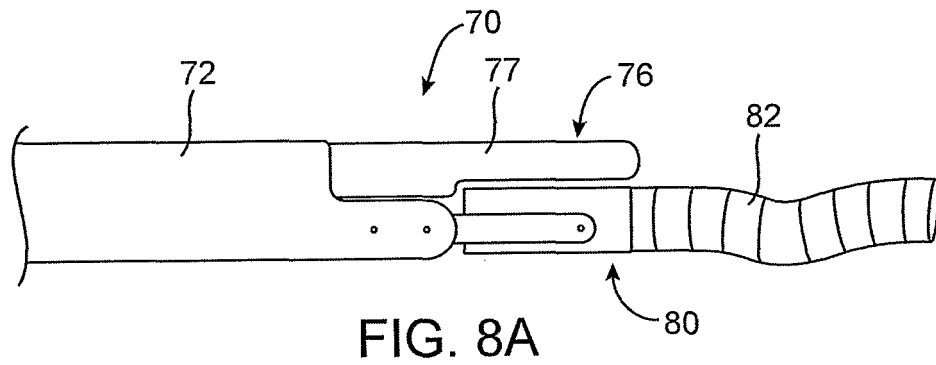

FIG. 8A

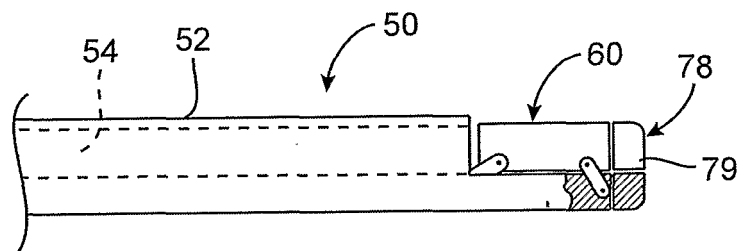
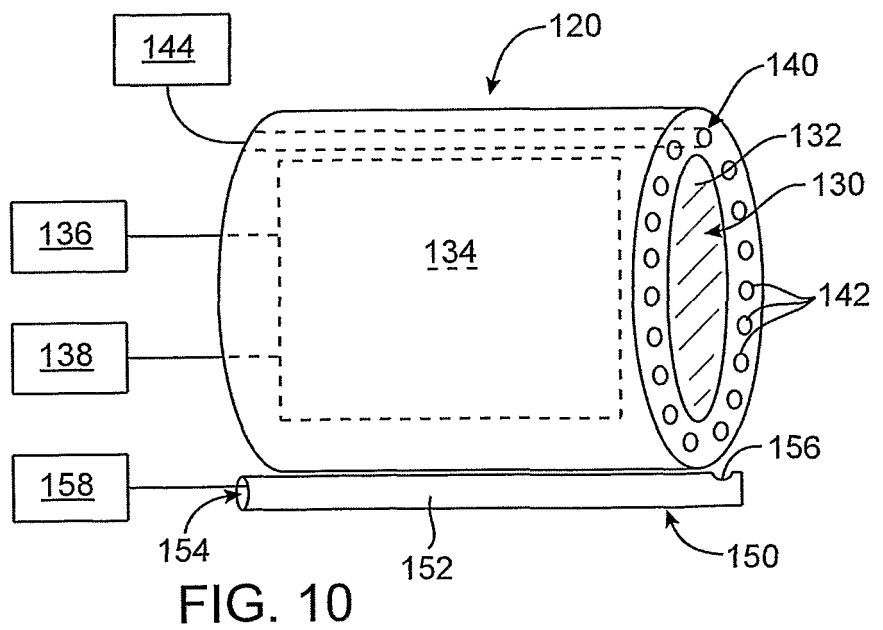
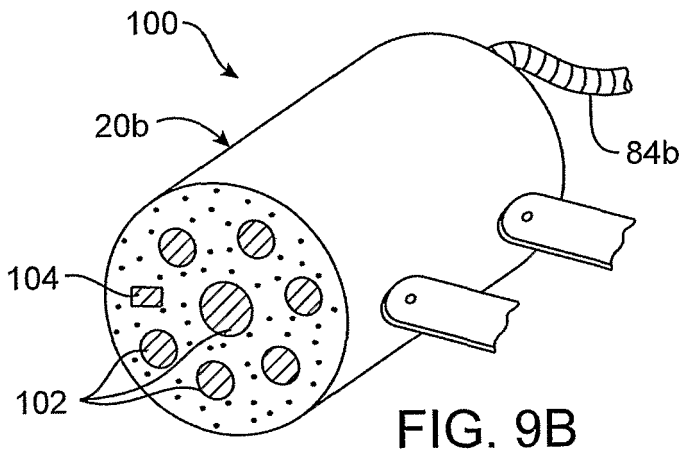
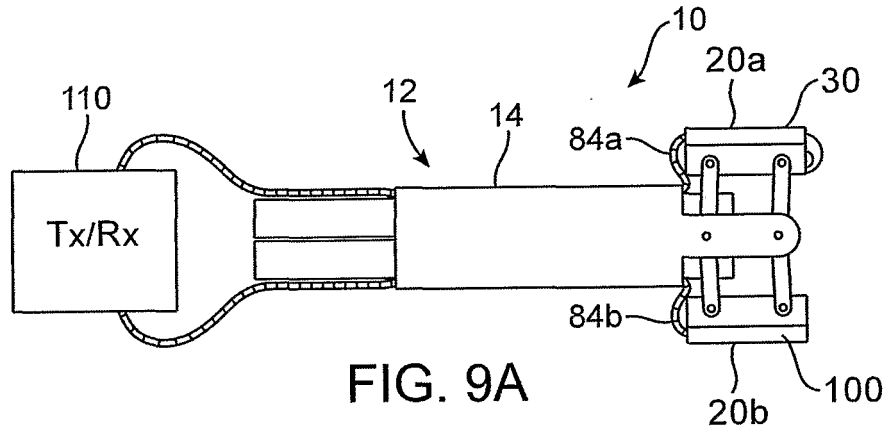

FIG. 8B



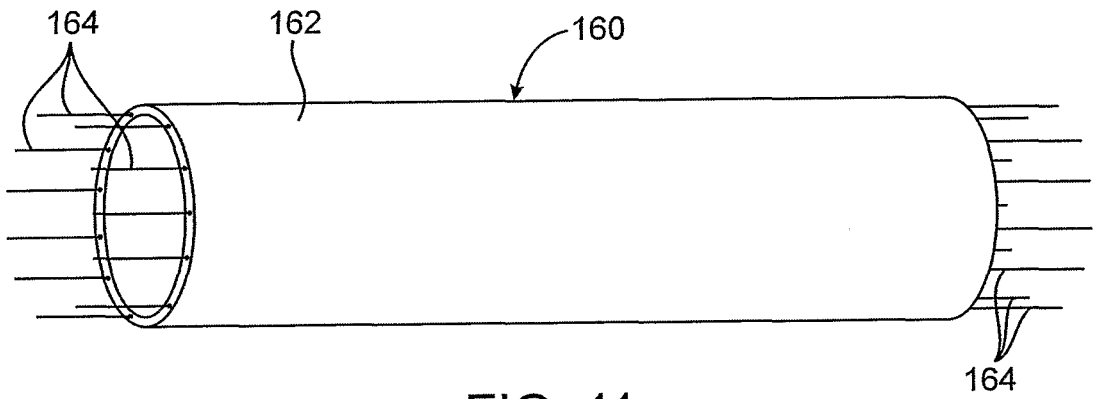

FIG. 11

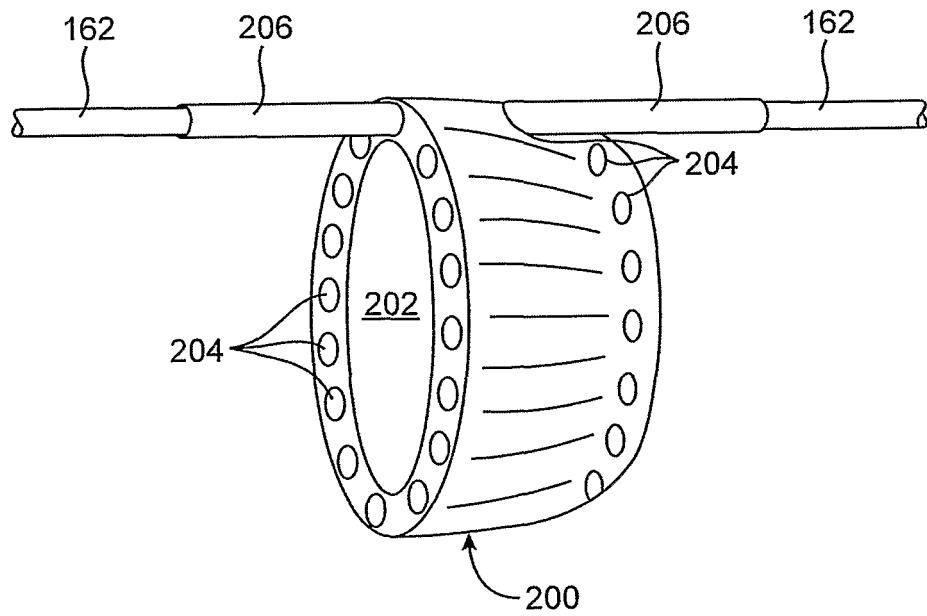

FIG. 12

7 / 11

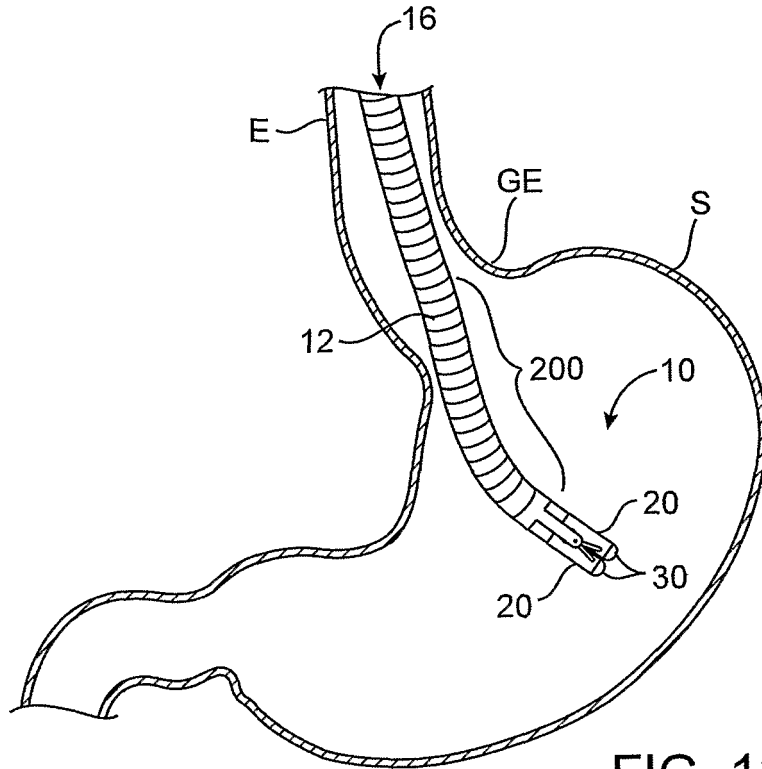

FIG. 13A

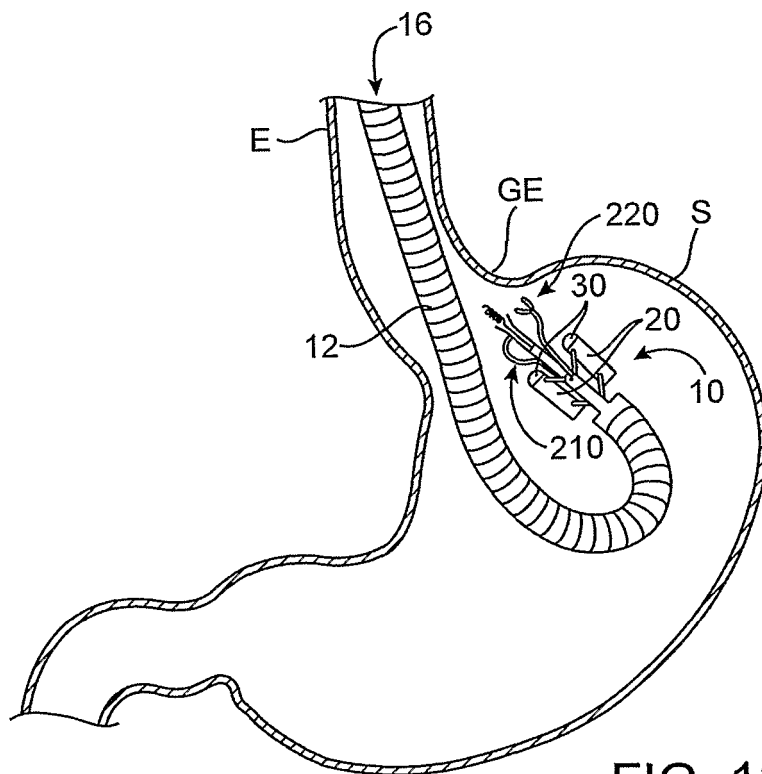

FIG. 13B

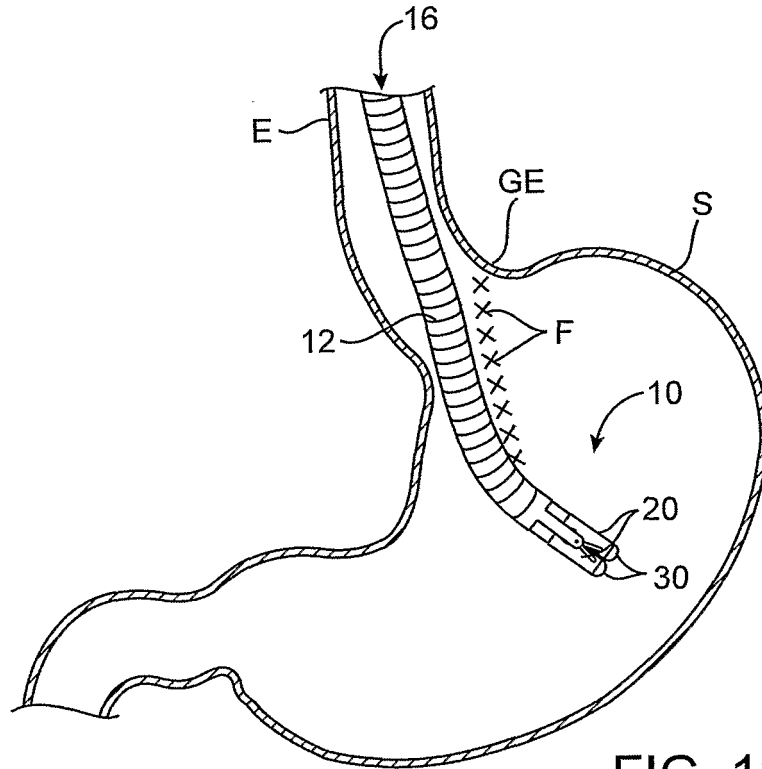

FIG. 13C

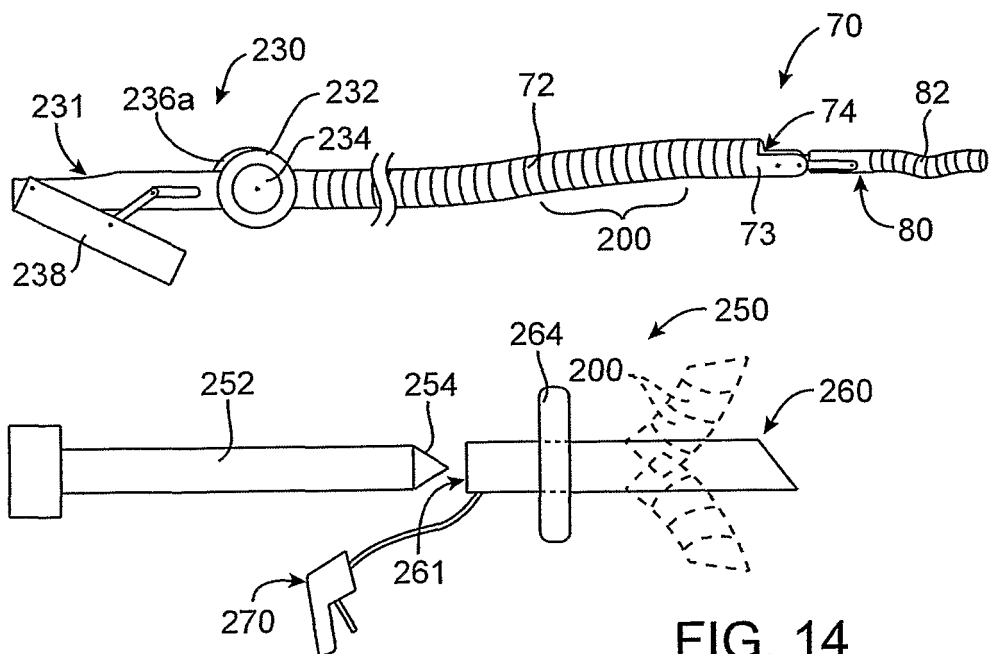

FIG. 14

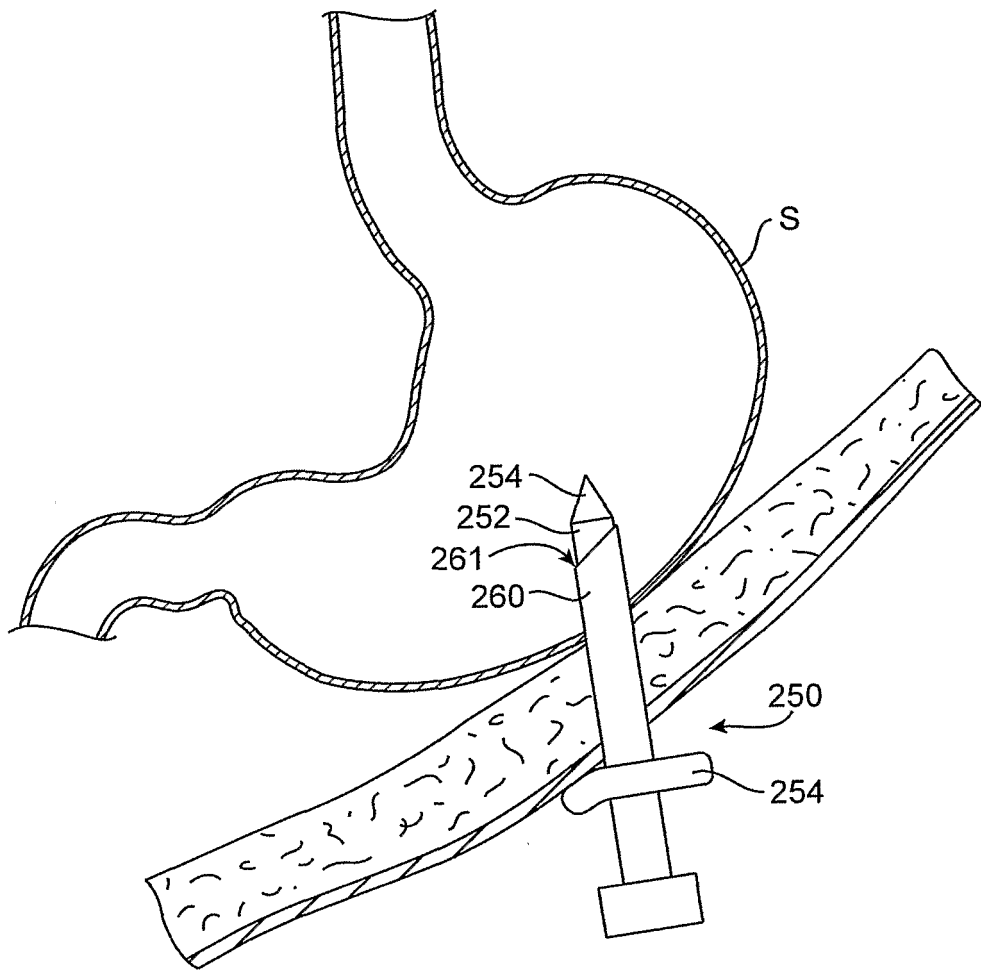

FIG. 15A

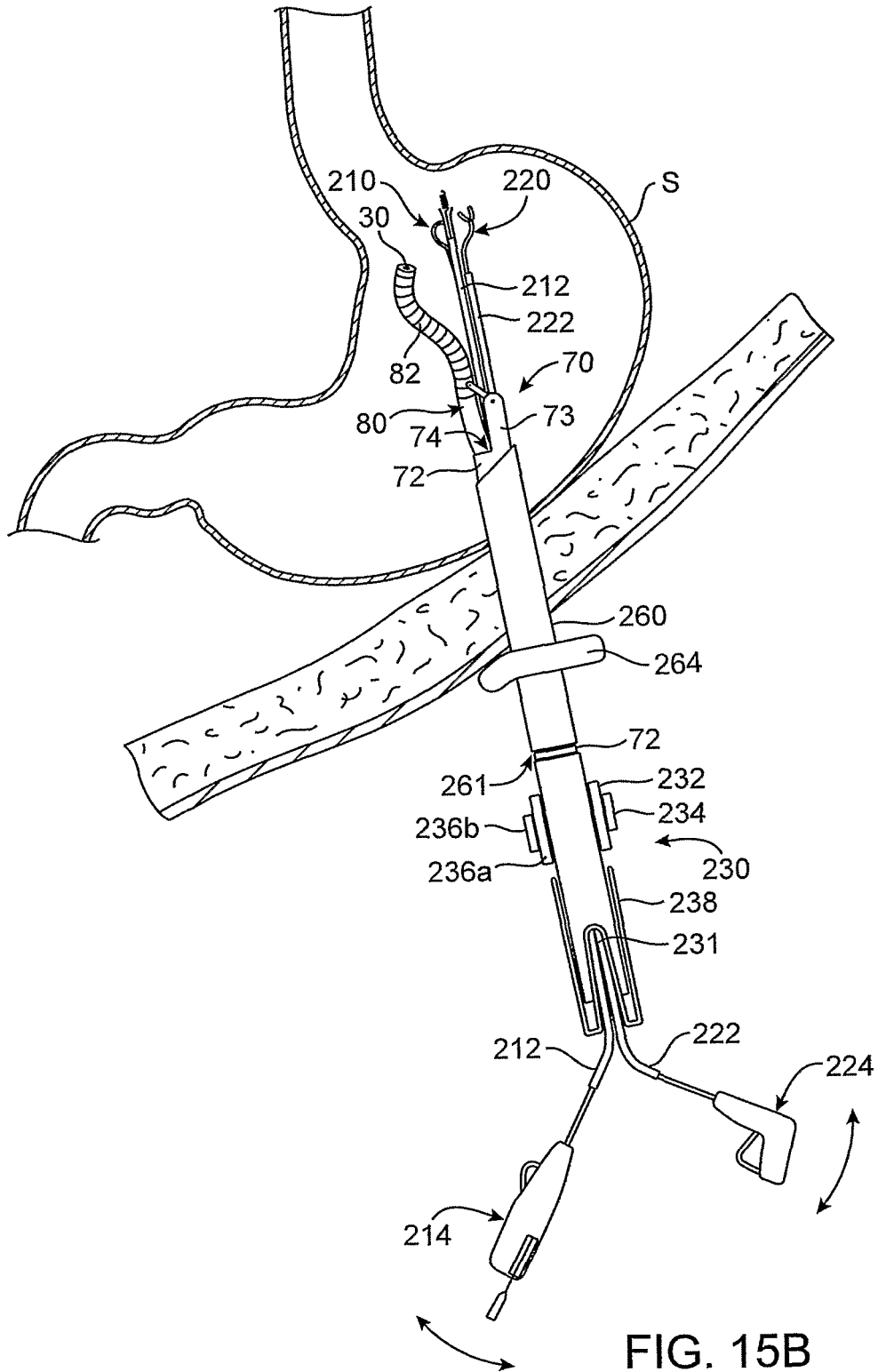

FIG. 15B

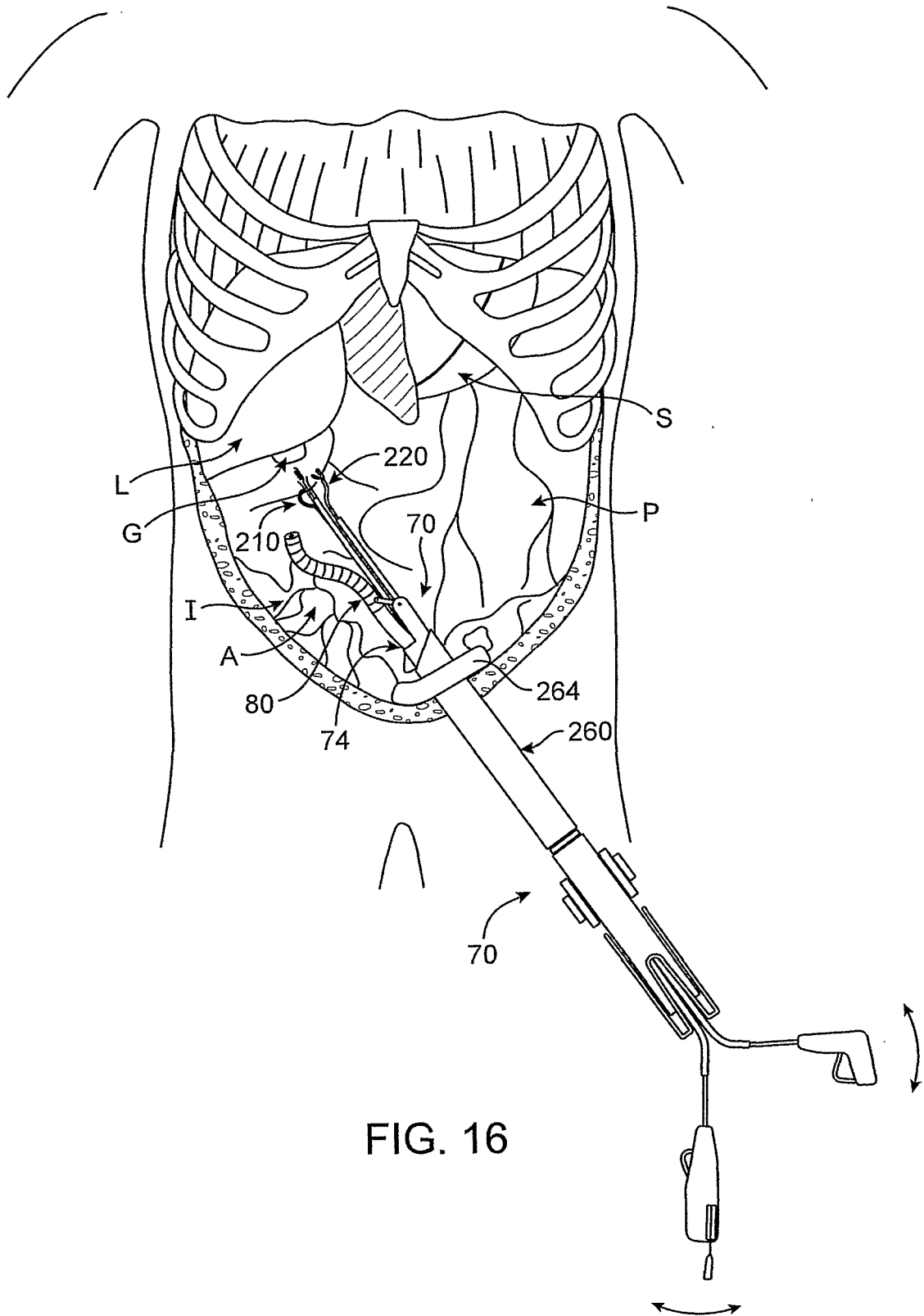

FIG. 16

专利名称(译)	获得腔内通路的方法和装置		
公开(公告)号	EP1755435A2	公开(公告)日	2007-02-28
申请号	EP2005725998	申请日	2005-03-22
[标]申请(专利权)人(译)	USGI医疗		
申请(专利权)人(译)	USGI MEDICAL INC		
当前申请(专利权)人(译)	USGI MEDICAL INC		
[标]发明人	SAADAT VAHID COX JOHN A ROTHER CHRIS A		
发明人	SAADAT, VAHID COX, JOHN, A. ROTHER, CHRIS, A.		
IPC分类号	A61B1/01 A61B1/04 A61B1/00 A61B1/018		
CPC分类号	A61B17/3421 A61B1/0008 A61B1/00098 A61B1/00183 A61B1/00193 A61B1/018 A61B1/04 A61B2017/00278 A61B2017/3445 A61B2017/3447		
代理机构(译)	WORK , 伊利亚		
优先权	10/824936 2004-04-14 US 11/036029 2005-01-14 US		
外部链接	Espacenet		

摘要(译)

本发明提供了用于获得腔内通路的方法和装置。细长主体构造成用于插入体腔，导管，器官，孔口，通道或腔体内，细长主体具有工作轴线和远端区域，以及设置在远端区域附近的铰接元件，铰接元件构造成铰接的离细长体的工作轴偏离轴线。细长物可以以腔内或腹腔镜方式进入。还提供了使用该装置的方法。