

(19) World Intellectual Property
Organization
International Bureau



(43) International Publication Date
12 August 2004 (12.08.2004)

PCT

(10) International Publication Number
WO 2004/066827 A2

- (51) International Patent Classification⁷: **A61B**
- (21) International Application Number: PCT/US2004/000695
- (22) International Filing Date: 13 January 2004 (13.01.2004)
- (25) Filing Language: English
- (26) Publication Language: English
- (30) Priority Data: 10/346,846 17 January 2003 (17.01.2003) US
- (71) Applicant (for all designated States except US): **APPLIED MEDICAL RESOURCES CORPORATION** [US/US]; 22872 Avenida Empresa, Rancho Santa Margarita, CA 92688 (US).
- (72) Inventors; and
- (75) Inventors/Applicants (for US only): **HART, Charles, C.** [US/US]; 126 Marvin Gardens, Summerville, SC 29483-8949 (US). **BRUSTAD, John, R.** [US/US]; 34056 Formosa Drive, Dana Point, CA 92629 (US).
- (74) Agent: **MYERS, Richard, L.**; 22872 Avenida Empresa, Rancho Santa Margarita, CA 92688 (US).
- (81) Designated States (unless otherwise indicated, for every kind of national protection available): AE, AG, AL, AM, AT, AU, AZ, BA, BB, BG, BR, BW, BY, BZ, CA, CH, CN, CO, CR, CU, CZ, DE, DK, DM, DZ, EC, EE, EG, ES, FI, GB, GD, GE, GH, GM, HR, HU, ID, IL, IN, IS, JP, KE, KG, KP, KR, KZ, LC, LK, LR, LS, LT, LU, LV, MA, MD, MG, MK, MN, MW, MX, MZ, NA, NI, NO, NZ, OM, PG, PH, PL, PT, RO, RU, SC, SD, SE, SG, SK, SL, SY, TJ, TM, TN, TR, TT, TZ, UA, UG, US, UZ, VC, VN, YU, ZA, ZM, ZW.
- (84) Designated States (unless otherwise indicated, for every kind of regional protection available): ARIPO (BW, GH, GM, KE, LS, MW, MZ, SD, SL, SZ, TZ, UG, ZM, ZW), Eurasian (AM, AZ, BY, KG, KZ, MD, RU, TJ, TM), European (AT, BE, BG, CH, CY, CZ, DE, DK, EE, ES, FI, FR, GB, GR, HU, IE, IT, LU, MC, NL, PT, RO, SE, SI, SK, TR), OAPI (BF, BJ, CF, CG, CI, CM, GA, GN, GQ, GW, ML, MR, NE, SN, TD, TG).
- Published: — without international search report and to be republished upon receipt of that report
- For two-letter codes and other abbreviations, refer to the "Guidance Notes on Codes and Abbreviations" appearing at the beginning of each regular issue of the PCT Gazette.

(54) Title: SURGICAL ACCESS APPARATUS AND METHOD

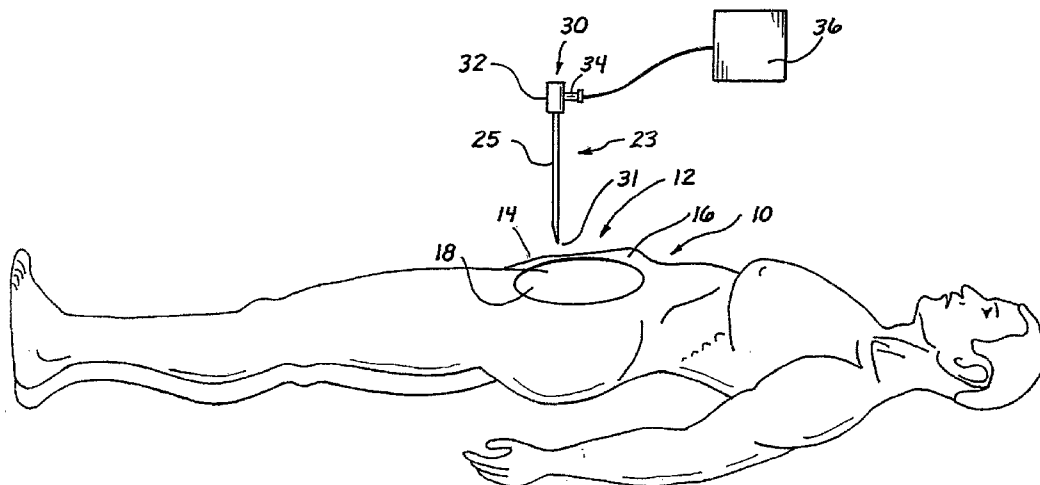

(57) Abstract: A laparoscopic insufflation device is provided in the configuration of a coil with a blunt tip. The device is capable of passing through the abdominal wall without cutting tissue, and exiting the abdominal wall substantially parallel to the inner surface. While rotation of the coiled device results in forward movement through the abdominal wall, a counter force can be applied to the device to create a safety space between the wall and the interior organs. With the blunt distal tip, parallel exit angle, and safety space, there is substantially no threat to the interior organs during placement of the device. Further space can be generated with the use of pressured gas to produce an abdominal cavity for the subsequent placement of trocars. By rotatably attaching the coiled insufflation device to a trocar, the advantage of a counter force can be used not only to establish the safety space but also to pull the trocar into the abdominal wall with a counterforce which resists tenting.

WO 2004/066827 A2

SURGICAL ACCESS APPARATUS AND METHOD

BACKGROUND OF THE INVENTION

5

Field of the Invention

This invention relates generally to surgical access devices and more specifically to trocars and insufflation devices used in laparoscopic surgery.

10

Discussion of Related Art

Abdominal inflation is a critical component of Laparoscopic Surgery. The most common method to achieve inflation, more commonly referred to as insufflation, is to pass a sharp needle through the abdominal wall and into the inner abdominal region, and then inject a gas through the needle and into the region thereby creating an enlarged or ballooned cavity to accommodate a laparoscopic procedure. Unfortunately, insertion of the needle has been required without any visual aid to facilitate location of the sharp needlepoint. In order to reduce the probability of inadvertent penetration of delicate internal organs in this "blind" procedure, the sharp insufflation needle has been provided with a spring-loaded and retractable safety mechanism.

20

The safety mechanisms associated with most insufflation needles consist of a blunt or rounded member disposed within the lumen of the needle, and biased by a spring to an extended position beyond the needle tip. This spring must be responsive to the insertion pressure during placement of the

25

needle but must be capable of immediately moving forward when that pressure is relieved. This is highly mechanical event and at best, offers a less than optimal arrangement.

In order to make the insertion of sharp needles into the abdominal region safer, a common practice has developed where the needle is inserted at an angle to the tissue plane. This of course requires that the needle traverse a greater distance through the abdominal tissue, so the maximum angle is always limited by the length of the needle.

Notwithstanding these attempts to reduce the probability and severity of an adverse consequence, many inadvertent injuries continue to result from the blind insertion of insufflation needles.

SUMMARY OF THE INVENTION

In a preferred embodiment of the present device, a length of hollow tubing, configured as a helix, is provided with a closed and rounded distal end. At least one distal side opening allows insufflation gas to exit the spiral tube at the distal end. The proximal end of the spiral tube is fitted with a connecting hub and a valve for connection to a gas supply. In operation, the spiral tube is inserted into a small skin incision and subsequently rotated to separate or part abdominal tissue until the distal end emerges from the abdominal wall and into the abdominal region. A significant characteristic of the spiral tube is that its distal tip emerges nearly parallel to the plane of the inner surface of the

abdominal wall and the adjacent internal organs. With this orientation, the blunt distal end of the device presents no danger to these delicate internal structures.

In one aspect, a laparoscopic insufflation needle is adapted for movement across an abdominal wall of a patient to insufflate an abdominal region of the patient, the needle comprises an elongate tube having an inflation channel extending between a proximal end and a distal end. The tube is adapted at the proximal end for connection to a source of fluid under pressure, and is adapted at its distal end to expel the fluid under pressure to insufflate the abdominal region of the patient. An optical element can be disposed at the distal end of the elongate tube to facilitate visualization of the abdominal wall and the abdominal region of the patient.

In another aspect, an insufflation needle is adapted for movement across an abdominal wall and into an abdominal region of a patient. The needle includes an elongate tube for insufflating the abdominal region with a fluid under pressure. The tube is configured to provide a mechanical advantage when moved across the abdominal wall.

In another aspect, the insufflation needle includes an elongate tube for insufflating the abdominal region with a fluid under pressure. The elongate tube at its distal end is angled relative to the proximal end of the tube to produce an exit angle with an interior surface of the abdominal wall. This exit angle is in a range of less than about 40 degrees in order to inhibit penetration of interior organs of the patient.

In another aspect, the elongate tube of the insufflation needle has a distal end with a distal tip that is free of sharp edges to inhibit cutting the abdominal wall during penetration of the abdominal wall, and to inhibit cutting the interior organs following penetration of the abdominal wall.

5 An associated method for accessing an abdominal region of the patient by crossing an abdominal wall of the patient, includes the steps of providing an insufflation needle in the configuration of a tube, and turning the tube to facilitate the crossing of the abdominal wall with the insufflation needle.

In another method, an access device is used to create an
10 abdominal cavity in an abdominal region containing interior organs of the patient. The method includes the steps of providing an elongate shaft having an axis extending between a proximal end and a distal end, and moving the shaft across the abdominal wall to place the distal end of the shaft in the abdominal region. Following this placement, the elongate shaft can be pulled to move the
15 abdominal wall away from the interior organs and to create the abdominal cavity around the interior organs in the abdominal region.

In a further aspect, a surgical device is adapted to provide access across an abdominal wall and into an abdominal region of a patient. The device includes a trocar having a cannula, and a shaft having a proximal end and a
20 distal end. The shaft has the configuration of a coil with a coil axis, the coil being adapted to facilitate rotational movement of the shaft across the abdominal wall. The proximal end of the shaft is coupled to the trocar so that movement by the

shaft across the abdominal wall is accompanied by movement of the trocar into the abdominal wall.

In an associated method, a trocar is placed across an abdominal wall of a patient by providing a shaft in the form of a coil having a proximal end and a distal end. The proximal end of the coil is coupled to the trocar so that
5 screwing the coil into the abdominal wall moves the trocar with the shaft into the abdominal wall with a mechanical advantage which is dependent upon the configuration of the coil.

In a further aspect, an anchor is adapted for use with a trocar
10 having a cannula configured for placement in an operative position across an abdominal wall. The anchor includes a structural element adapted to be coupled to the trocar and to extend outwardly of the cannula, the structural element having characteristics for engaging the abdominal wall at a location spaced from the cannula to inhibit withdrawal of the cannula from the operative position of the
15 cannula.

DESCRIPTION OF THE DRAWINGS

20 FIG. 1 is a side view of a patient in a prone position and prepared for laparoscopic surgery;

FIG. 2 is a top plan view showing organs internal to an abdominal region of the patient;

FIG. 3 is a side elevation view of the patient with an inflated abdominal cavity,

FIG. 4 is a perspective view of an insufflation needle of the prior art;

FIG. 5 illustrates an initial step in an insertion method associated with the insufflation needles of the prior art;

FIG. 6 illustrates an undesirable puncture of internal organs which can result when using the insufflation needles of the prior art;

FIG. 7 is a perspective view of one embodiment of the present insufflation device;

FIG. 8 is an enlarged perspective view of one embodiment of a distal end portion of the insufflation device illustrated in Figure 7;

FIG. 9 is an enlarged perspective view of the distal end portion of an alternate embodiment of the insufflation device;

FIG. 10 is a perspective view of an alternate embodiment of the device including a distal tip emitting visible light;

FIG. 11 is an enlarged perspective view of the distal end portion in another embodiment of the insufflation device;

FIG. 12 is an enlarged perspective view of the distal end portion in a further embodiment of the insufflation device;

FIG. 13 is an enlarged cross-section view of the abdominal wall showing an initial step in a preferred method for insertion of the device;

FIG. 14 is an enlarged cross-sectional view of the abdominal wall showing a continuing step in a preferred method for insertion;

FIG. 15 is a close-up view of the abdominal wall illustrating a further step in the insertion method as the distal end emerges in close proximity to the internal organs of the patient;

FIG. 16 is a schematic perspective view of the device within the
5 abdominal wall;

FIG. 17 is a perspective view of a wound site after removal of the device;

FIG. 18 is a front elevation view of a combination including an insufflation device rotatably attached to a trocar; and

10 FIG. 19 is a front elevation view showing the combination of FIG. 18 in use to cross the abdominal wall.

DESCRIPTION OF PREFERRED EMBODIMENTS

AND BEST MODE OF THE INVENTION

15 A patient is illustrated in Figure 1 and designated generally by the reference numeral 10. The patient 10 is shown in a prone position with his abdomen 12 facing upwardly as he is readied for laparoscopic surgery. In this process, minimally invasive surgery is undertaken through an abdominal wall 14
and within an abdominal region 16 of the patient. This laparoscopic surgery
20 commonly involves internal organs 18 as best illustrated in Figure 2. Rather than accessing these internal organs 18 through a large opening in the abdominal wall 14, laparoscopic surgery calls for minimal invasion of the abdominal wall 14

through tubular access devices, commonly referred to as trocars. These trocars are designated by the reference numeral 20 in Figure 3.

The trocars 20 are placed through small openings in the abdominal wall to provide access for visualization and surgical instruments. They are commonly provided with sharp points which although facilitating puncture of the abdominal wall, can be particularly threatening to the internal organs 18 which initially are in close proximity to the abdominal wall.

It is for this reason that placement of the trocars 20 is commonly preceded with inflation of the abdominal region in order to create an abdominal cavity 21. This initial step of inflating or insufflating the abdominal region 16 produces space between the abdominal wall 14 and the internal organs 18 as best illustrated in Figure 3. With this separation or space, placement of the trocars 20 is facilitated with a reduced threat to the internal organs 18. Formation of the abdominal cavity 21 also increases the size of the operative environment and enhance visualization of the operative procedure.

Creation of the abdominal cavity 21 has typically been accomplished using an insufflation or Veress needle 23 as illustrated in Figure 1. This needle 23 has included an elongate cannula 25 having a distal end 27 and a proximal end 30. At the distal end 27, the cannula has been provided with a sharp distal tip 31 of comparative interest to the present invention. At the proximal end 30, the cannula 25 has been coupled through a housing 32 to a connector 34. A source of gas under pressure 36 has been coupled to the connector 34 to provide the insufflation gas through the cannula 25.

It is of particular importance to note that when the Veress needle 23 of the past is initially forced through the abdominal wall 14, there is no abdominal cavity 21. As a consequence, the internal organs 18 are not spaced from the abdominal wall 14, but are disposed closely adjacent to the abdominal wall 14 as illustrated in Figure 1. In order to avoid puncture of these internal organs 18 by the sharp distal tip 31 of the insufflation needle 23, a spring actuated safety member 38 has been provided as best illustrated in the enlarged view of Figure 4.

Note that the present procedure for placement of the Veress needle has generally required that the needle be inserted perpendicular to the abdominal wall 14. This has produced a perpendicular exit angle with an inner surface 39 of the abdominal wall 14, and most importantly has produced a highly detrimental perpendicular relationship between the Veress needle 23 and the interior organs 18.

In order to fully understand this critical moment when an access device first emerges from the abdominal walls, reference is now made to Figure 5 which shows a greatly enlarged view of the abdominal wall 14 with the internal organs 18 in close proximity. At the particular time illustrated, the Veress needle 23 has been forced through the abdominal wall 14 and the sharp distal tip 31 has just become exposed at an inner surface 39 of the abdominal wall 14. With the intent of avoiding any damage to the internal organs 18 by the sharp distal tip 31, the safety member 38 has been deployed in this limited time and narrow space to shield the distal tip 31.

The mechanical requirements of this safety member deployment have limited the timeliness of this protection with consequent damage to the internal organs 18. While the safety member 38 reduces the probability of organ damage, the severity of this adverse occurrence remains significant.

5 Furthermore, if a blood vessel is cut or an organ penetrated, the insufflation gas pressure will tend to inhibit any leakage that might alert one to the damage. Under these circumstances, the procedure can be fully completed with the resulting damage becoming apparent only after the insufflation pressure has been relieved and the operative site has been closed. This threatened exposure
10 of the interior organs 18 can also be seen in the wider view of Figure 6

It can be seen from Figures 5 and 6 that great care has been required during insertion of the Veress needle 23 in order to avoid damage to the adjacent internal organs 18. The needle 23 is commonly inserted through the abdominal wall 14 by pushing forward or distally. The forward motion must be
15 carefully controlled to avoid overshooting the abdominal wall 14 and inadvertently penetrating one of the internal organs 18 before the safety member 38 can respond and move forward to shield the sharp tip 31. This has required that the spring force be carefully balanced between that which is required to penetrate the abdominal wall 14 and that which is required to prevent penetration of the
20 internal organs 18.

As illustrated in Figure 5, the abdominal wall 14 consists of skin 41, layers of muscle 43 and a layer of connective tissue 45. In addition, there is a final, internal membrane 47 referred to as the peritoneum. This membrane 47,

which forms the inner surface 39 of the abdominal wall 14, may be very thin and delicate or it may be very tough. In the latter case, the safety member 38 associated with the distal end 27 of the Veress needle 23 may be unable to respond in sufficient time to be effective, particularly if the peritoneum exerts an elastic load as the needle 23 is urged forward. In short, an abrupt rupture of the peritoneum 47 may allow a sharp, unshielded tip to penetrate the internal organs 18 before the safety member 38 can respond.

Referring to Figure 7, a preferred embodiment of an insufflation device 101 of the present invention is shown in the configuration of a coil 102 formed of a spiraled length of hollow tubing 103. The coil 103 has a diameter 104, and an axis 105 extending between a proximal end 107 and a distal end 110.

At the distal end 110, a distal tip 111 can be rounded or blunted to ensure that there are no sharp edges to cut or tear body tissue. The distal end 110 may have at least one side port 112 that permits gas to escape from the lumen of the tubing 103. The proximal end 107 of the coil 102 may include a tubular extension 114 terminating in a connector 116 which is adapted to be coupled to the source of gas 36 (Figure 1). The coil 102 can be formed with individual convolutions 118 which are spaced to provide maximum engagement with the body tissue while avoiding overcompression and necrosis of the tissue

With reference to Figure 8, it will be appreciated that the distal end 110 of the coiled insufflation device 101 can be substantially or completely closed and formed with a hemispherical distal tip 111 providing a smooth transition to

the coiled tubing 103. The side port 112 is preferably sized and configured to deliver maximum gas flow from the coiled tubing 103 to the abdominal cavity 21.

In an alternate embodiment illustrated in Figure 9, the distal tip 111 is formed from a material that is optically clear. This allows use of an optical viewing device 121, such as an endoscope, angioscope or the like. In such an embodiment, the optical viewing device 121 could be disposed in the lumen of the coiled tubing 103 and subsequently advanced to the distal end 110 for visually monitoring insertion of the insufflation device 101.

It will be noted by comparison, that in the past, insertion of the Veress needle 23 was a blind procedure which presented the greatest threat to the internal organs 18 (Figure 2). Only after the Veress needle 23 had created the inflated abdominal cavity 21 and the first trocar 20 was placed, could an endoscope be inserted to facilitate visualization during insertion of subsequent trocars. With the present device, this visualization is available to provide for safe placement of the access device which initially crosses the abdominal wall 14.

In another embodiment illustrated in Figure 10, the optical viewing device 121 may include an illumination device or light 130 within the lumen of the coiled tubing 103. In this case, the light 130 will produce an illuminated area 132 that is viewable from outside the body of the patient 10. This form of viewing, which is commonly referred to as transillumination, provides a clear indication as to the position of the distal end 110 when it has reached a preferred location. The indication may be some change in the emission characteristics of the light

130, or may result from diffusion of the omitted light in a manner that indicates proper placement.

Referring now to Figures 11 and 12, the distal tip 111 of the coiled tubing 103 may present an end condition that is not rounded. For instance, the coil tubing 103 may terminate in a straight perpendicular surface 125 as illustrated in Figure 11. In this case, the lumen of the tubing 103 would be unobstructed.

In the embodiment of Figure 12, the distal end 110 is provided with a sharp, pointed tip 127. Although the preferred embodiment of the present invention comprises a blunt or rounded tip 111, the sharp tip 127 of the Figure 12 embodiment still offers the significant advantage associated with the reduced entry and exit angles provided by the coil construction.

These entry and exit angles can be further appreciated with reference to Figures 13, 14, and 15 which show progressive positions of the insufflation device 101 as it is maneuvered through the abdominal wall 14. In Figure 13, a nick 134 has been made in the skin 41 of the wall 14. By placing the axis 105 of the coil 102 at an angle to the abdominal wall 14, the entry angle of the distal tip 121 can be increased to facilitate passage through the nick 134. In Figure 13, this entry angle is designated by the Greek letter α . After the nick 134 has been penetrated, the coil 102 is preferably oriented so that its axis 105 is substantially perpendicular to the abdominal wall 14 as illustrated in Figure 14. This greatly reduces the entry angle α as the distal tip 121 passes through the

layer of muscle 43 and associated connective tissue 45 (Figure 5) which comprise the abdominal wall 14.

Continued penetration of the coiled tubing 103 through the abdominal wall 14 is illustrated in Figure 14. As the coil 102 passes through the abdominal wall 14, as illustrated in the enlarged view of Figure 15, the distal tip and the following convolutions 118 exit the wall 14 at an exit angle designated by the Greek letter β in Figure 15.

It is this exit angle β which is of particular importance to the present invention. Although this angle is measured with respect to an inner surface 136 of the abdominal wall 14, it can be appreciated that the internal organs 18 are also in contact with, or generally parallel to this inner surface 136. Accordingly, the exit angle β is also the angle which the distal tip 121 presents to the internal organs 18. When this angle is generally perpendicular, as in the past (see Figure 6), the probability of organ penetration is great. However, when this exit angle β is reduced to a very small acute angle, the distal tip 111 tends to slide along the surface of the internal organs 18, particularly if the distal tip 111 has a blunt configuration as first discussed with reference to Figure 8.

In Figure 16, the coiled device 101 of the present invention is illustrated schematically so that one can appreciate the forces associated with placement of the device 101 through the body wall 14. In the past, the straight Veress needle 23 (Figure 1) would be placed using a force applied in the same direction as that desired for movement of the device 101, specifically a forward force applied in the direction represented by an arrow 150. Note that the

insufflation device 101 of the present embodiment moves in the desired forward direction 150, but does so only in response to a rotational force represented by an arrow 152. The forward direction of movement illustrated by the arrow 150, may even be realized while the coiled tubing 103 is pulled backwardly by a force
5 opposite to the forward direction of arrow 150. In other words, once the distal tip 111 is adequately engaged within the abdominal wall 14, Figure 13, preferably within a small skin incision or nick 134 (Figure 13), the entire device 101 may be held in traction rather than pushed to provide the desired forward motion. The coiled tubing 103 acts as a "corkscrew" and propels or advances itself in the
10 forward direction 150, but only in response to rotational motion shown by arrow 152. This tractional rotation of the coiled tubing 103 tends to provide a safety margin as the body wall 14 is pulled or drawn away from the internal organs 18.

With further reference to Figure 7, it can be seen that the present invention may comprise larger than ordinary tubing 103 since the placement
15 force is not perpendicular to the abdominal wall 14 and internal organs 18. In fact, the placement force, as shown by arrow 152, is rotational and incremental rather than direct and uncontrollable. In addition, the slow and deliberate advancement of the blunt distal end 110 gradually parts tissue, such as the skin 41, muscle 43, and connective tissue 45 in a more natural manner than with the
20 straight, cutting penetration of the past. The blunt distal end 110 tends to wind its way through body tissue seeking weak, less dense or fatty tissue, and avoiding included blood vessels, and muscle that is normally more vascular than fatty tissue.

An insertion site 21 associated with the present invention is shown in Figure 17 at a time when the device 101 has been removed, and the tissue, previously separated by the procedure, has generally returned to its original condition. Since little or no cutting has occurred, there is minimal bleeding and no potential for herniation of the site. A track 154 through which the device 101 passes as it is rotated through the tissue, has the same length and convoluted nature as the device 101 itself. With respect to the track 138, its length, convoluted nature and general lack of cut tissue provides improved healing even though the diameter size of the insufflation device 101 may have been as much as two or three times that of existing insufflation needles.

With further reference to this enlarged diameter, it will be noted that the insufflation device 101 can provide a gas flow significantly greater than existing insufflation needles. But even if the diameter or gauge size of the present insufflation device 101 is the same as that of the prior art, its gas flow will be significantly greater primarily due to the lack of obstruction in the lumen of the tubing 103.

Many of the advantages associated with the coiled insufflation device 101 can be further appreciated in combination with a trocar, such as the trocar 20 discussed with reference to Figure 3. In this combination, illustrated in Figure 18, the trocar 20 is shown to have a valve housing 141, a cannula 143, and a removable obturator 145. The coiled insufflation device 101 is rotatably attached to the trocar 20, for example with an attachment ring 147.

The trocar 20 is preferably disposed inside of and coaxial with the coiled insufflation device 101. With this orientation, the device 101 is free to rotate on its axis around the cannula 143 of the trocar 20. The device 101 will typically be as long as, if not slightly longer than, the cannula 143 so that the
5 distal tip 111 extends at least to the tip of the obturator 145.

Operation of this combination is illustrated in Figure 19. As the coiled insufflation device 101 is rotated into the abdominal wall 14 of the patient, it advances in the manner previously discussed. Due to its attachment to the trocar 20, this advancement tends to pull the trocar into the abdominal wall 14.
10 One major advantage associated with this combination is that the device 101 provides an outward counter force which resists any tendency of the abdominal wall 14 to tent inwardly due to the forward movement of the trocar 20.

This system would be particularly useful for bariatric patients which have a large quantity of abdominal wall fat. In these patients, it is common
15 practice to introduce the trocar at a slight angle to the patient's abdominal wall 14 in order to maintain it in place. Often a large amount of leverage must be applied against the trocar to overcome the bulk of abdominal wall fat. This in turn widens the trocar entry wound and makes slippage of the trocar more likely. With the combination of the trocar 20 and insufflation device 101, the surgeon will not
20 have to fight the abdominal wall during insertion and will further benefit from the tremendous retention provided by the insufflation device 101.

A further advantage associated with this combination can be appreciated by noting that trocars are typically placed normal to the surface of

the abdominal wall 14 and also normal to the peritoneum. In the past, when the trocar 20 was pushed inwardly, the abdominal wall tented inwardly after the muscular layer of the abdominal wall 14 was penetrated, this inward force was applied directly to the peritoneum and tended to separate the peritoneum from the remainder of the abdominal wall. With the present combination, the coiled insufflation device 101 engages the peritoneum and holds it against the remainder of the abdominal wall as the trocar 20 is pulled inwardly. As a result, the peritoneum does not dissect from the abdominal wall.

It will be understood that many other modifications can be made to the various disclosed embodiments without departing from the spirit and scope of the concept. For example, various sizes of the surgical device are contemplated as well as various types of constructions and materials. It will also be apparent that many modifications can be made to the configuration of parts as well as their interaction. For these reasons, the above description should not be construed as limiting the invention, but should be interpreted as merely exemplary of preferred embodiments. Those skilled in the art will envision other modifications within the scope and spirit of the present invention as defined by the following claims.

CLAIMS

1. A laparoscopic insufflation needle adapted for movement across an abdominal wall of a patient to insufflate an abdominal region of the patient, the insufflation needle comprising:

5 an elongate tube having an inflation channel extending between a proximal end and a distal end, the elongate tube being adapted at the proximal end for connection to a source of fluid under pressure, and being adapted at the distal end to expel the fluid under pressure to insufflate the abdominal region of the patient; and

10 an optical element disposed at the distal end of the elongate tube to facilitate visualization of the abdominal wall and the abdominal region of the patient.

2. The laparoscopic insufflation needle recited in Claim 1, wherein the optical element is a light.

3. The laparoscopic insufflation needle recited in Claim 1, wherein the optical element is an endoscope.

4. The laparoscopic insufflation needle recited in Claim 2, wherein the light is adapted to facilitate transillumination of the abdominal wall of the patient.

5. The laparoscopic insufflation needle recited in Claim 1, wherein the distal end has a distal tip which is free of sharp edges to inhibit cutting the abdominal wall.

6. An insufflation needle adapted for movement across an abdominal wall and into an abdominal region of a patient, the Veress needle comprising:

an elongate tube having an inflation channel extending
5 between a proximal end and a distal end, the elongate tube being adapted at the proximal end for connection to a source of fluid under pressure, and being adapted at the distal end to expel the fluid under pressure to insufflate the abdominal region; and

the tube being configured to provide a mechanical
10 advantage when moved across the abdominal wall.

7. The insufflation needle recited in Claim 6, wherein the tube has the configuration of a coil with an axis and a diameter.

8. The insufflation needle recited in Claim 7, wherein the diameter is variable along the axis.

9. The insufflation needle recited in Claim 8, wherein the mechanical advantage is variable along the axis.

10. The insufflation needle recited in Claim 9, wherein the distal end has a distal tip free of sharp edges.

11. An insufflation needle adapted for penetrating an abdominal wall, having an inner service, defining an abdominal region containing interior organs of the patient, the needle comprising:

an elongate tube having an inflation channel extending
5 between a proximal end and a distal end. The elongate tube being adapted at the proximal end for connection to a source of fluid under pressure, and being adapted at the distal end to expel the fluid under pressure to insufflate the abdominal region;

the elongate tube at its distal end being angled relative to the
10 proximal end of the tube to produce an exit angle with the interior surface upon penetration of the abdominal wall; and

the exit angle being in a range of less than about 40 degrees in order to inhibit penetration of the interior organs of the patient.

12. The insufflation needle recited in Claim 11, wherein the distal end of the elongate tube is curved.

13. The insufflation needle recited in Claim 11, wherein the proximal end of the elongate tube produces an entry angle with the abdominal wall, and the entry angle is greater than the exit angle.

14. The insufflation needle recited in Claim 12, wherein the elongate tube is formed into a coil, having at least one convolution.

15. The insufflation needle recited in Claim 11, wherein the distal end of the elongate tube is substantially parallel to the inner surface of the abdominal wall upon penetration of the abdominal wall.

16. The insufflation needle recited in Claim 12, wherein the distal end of the elongate tube has a distal tip which is free of cutting edges.

17. An insufflation needle adapted for penetrating an abdominal wall having an inner surface defining an abdominal region containing interior organs of a patient, the needle comprising:

an elongate tube having an inflation channel extending
5 between a proximal end and a distal end, the elongate tube being adapted at the

proximal end for connection to a source of fluid under pressure and being adapted at the distal end to expel the fluid under pressure to insufflate the abdominal regions; and

the distal end of the elongate tube having a distal tip free of sharp edges to inhibit cutting the abdominal wall during penetration of the abdominal wall and to inhibit cutting the interior organs following penetration of the abdominal wall.

18. The insufflation needle recited in Claim 17, wherein the distal tip is blunt.

19. The insufflation needle recited in Claim 17, wherein the distal tip is defined by a curved surface

20. The insufflation needle recited in Claim 17, wherein the distal tip is translucent.

21. The insufflation needle recited in Claim 20 wherein the distal tip is transparent.

22. The insufflation needle recited in Claim 20, further comprising:
a light disposed in proximity to the translucent distal tip

23. The insufflation needle recited in Claim 21, further comprising:
an endoscope disposed in the elongate tube for viewing the abdominal region upon penetration of the abdominal wall.

24. A method for accessing an abdominal region of a patient by crossing an abdominal wall of the patient, comprising the steps of:
providing a Veress needle having the configuration of a tube extending between a proximal end and a distal end; and
5 turning the tube to facilitate the crossing of the abdominal wall with the Veress needle.

25. The method recited in Claim 24, wherein:
the providing step includes the step of forming the tube into a coil, having an axis, and

the turning step includes the step of rotating the coil to
5 facilitate crossing the abdominal wall of the patient with the elongate tube of the
Veress needle.

26 The method recited in Claim 25, wherein the rotating step
includes the step of rotating the coil about the axis.

27. The method recited in Claim 24, wherein the forming step
includes the step of:

forming the coil with at least one convolution to provide the
coil with a mechanical advantage during the turning step.

28. The method recited in Claim 25, wherein the rotating step
includes the steps of:

rotating the coil in a first direction to advance the Veress
needle into the abdominal wall; and

5 rotating the coil in a second direction to remove the Veress
needle from the abdominal wall.

29. A method for using an access device to create an abdominal cavity in an abdominal region containing interior organs of the patient comprising the steps of:

- providing an elongate shaft having an axis extending
- 5 between a proximal end and a distal end;
- moving the shaft across the abdominal wall to place the distal end of the shaft in the abdominal region; and
- pulling on the elongate shaft to move the abdominal wall away from the interior organs and to create the abdominal cavity around the
- 10 interior organs in the abdominal region of the patient.

30. The method recited in Claim 29, wherein the shaft has the configuration of a tube with a lumen extending along the axis between the proximal end and the distal end.

31. The method recited in Claim 30, further comprising the step of:

visualizing the abdominal cavity through the lumen of the tube.

32. The method recited in Claim 29, wherein the abdominal wall has the general configuration of a plane and the pulling step includes the step of:

pulling the shaft generally perpendicular to the plane of the abdominal wall.

33. The method recited in Claim 29, wherein the abdominal wall has an inner surface and the moving step includes the step of:

moving the elongate shaft through the abdominal wall with the distal end of the shaft crossing the inner surface at an exit angle generally
5 parallel to the inner surface of the abdominal wall.

34. The method recited in Claim 30, further comprising the steps of :

connecting the proximal end of the tube to a source of fluid under pressure; and

5 moving the fluid under pressure through the tube to insufflate the abdominal cavity of the patient.

35. The method recited in Claim 34, further comprising the step of:

expelling the fluid under pressure from the tube laterally of the tube.

36. The method recited in Claim 29, wherein:
the providing step includes the step of forming the shaft into
the configuration of a coil having an axis and at least one convolution; and
the moving step includes the step of screwing the coil into
5 the abdominal wall to place the distal end of the shaft into the abdominal region
of the patient.

37. A surgical device adapted to provide access across an
abdominal wall and into an abdominal region of a patient, comprising:
a trocar including a cannula;
a shaft having a proximal end and a distal end;
5 the shaft having the configuration of a coil with a coil axis,
the coil facilitating rotational movement of the shaft across the abdominal wall;
and
the proximal end of the shaft being coupled to the trocar so
that movement by the shaft across the abdominal wall is accompanied by
10 movement of the trocar into the abdominal wall.

38. The surgical device recited in 37, wherein the shaft is
rotationally coupled to the trocar so that the coil is free to rotate relative to the
trocar.

39. The surgical device recited in Claim 37, wherein:
the trocar has an axis; and
the trocar axis is generally coincidence with the coil access
40. The surgical device recited in Claim 39, wherein:
the trocar has a cannula with a distal tip forming a trocar exit
angle with the abdominal wall;
the shaft has a distal tip forming a shaft exit angle with the
5 abdominal wall; and
the trocar exit angle is greater than the shaft exit angle.
41. The surgical device recited in Claim 40, wherein the distal tip
of the cannula is generally perpendicular to the distal tip of the shaft.
42. The surgical device recited in Claim 41, wherein the distal tip
of the cannula is generally normal to the abdominal wall.
43. The surgical device recited in Claim 37, wherein the rotation
movement of the shaft across the abdominal wall provides a mechanical
advantage greater than unity to facilitate movement of the shaft across the
abdominal wall provides a mechanical advantage greater than unity to facilitate
5 movement of the trocar into the abdominal wall.

44. The surgical device recited in Claim 37, further comprising:
a ring rotation carried by the trocar; and
the proximal end of the shaft having a fixed relationship with
the ring and a rotational relationship with the trocar.

45. The surgical device recited in Claim 44, wherein the trocar
has a cannula and the ring is rotational supported by the cannula.

46. The surgical device recited in Claim 44, wherein the distal tip
of the cannula and the distal tip of the shaft each have a blunt configuration.

47. A method for placing a trocar across an abdominal wall of a
patient, comprising the steps of:

providing a shaft in the form of a coil, the shaft having a
proximal end and a distal end;

5 coupling the proximal end of the shaft to the trocar,

screwing the coil into the abdominal wall; and

moving the trocar with the shaft into the abdominal wall with
a mechanical advantage dependent on the coil.

48. The method recited in Claim 47, wherein the moving step
includes the step of pulling the trocar into the abdominal wall.

49. The method recited in Claim 47 wherein the moving step includes the step of lifting the coil to elevate the abdominal wall and to create an abdominal cavity.

50. The method recited in Claim 48, wherein the coil has an access and the pulling step includes the step of pulling the trocar along the axis of the coil.

51. An anchor adapted for use with a trocar having a cannula and being adapted for placement in an operative position across an abdominal wall, the anchor comprising:

a structural element adapted to be coupled to the trocar and
5 to extend outwardly of the cannula, the structural element having characteristics for engaging the abdominal wall at a location spaced from the cannula; and
the structural element having properties for inhibiting
withdrawal of the cannula from the operative position of the cannula.

52. The anchor recited in Claim 51, wherein the structural element comprises an elongate shaft disposed outwardly of the cannula.

53. The anchor recited in Claim 52, wherein the shaft has the configuration of a coil sized and shaped for disposition around the cannula.

54. The anchor recited in Claim 53, wherein the coil has a blunt distal tip.

55. The anchor recited in Claim 54, wherein the coil is adapted to be rotated into the abdominal wall to produce an inwardly directed force tending to move the trocar through the abdominal wall to the operative position and to maintain the trocar in the operative position across the abdominal wall.

56. The anchor recited in Claim 55, wherein:
the coil has a configuration including a diameter and a pitch,
and
the inwardly directed force is variable with the configuration
5 of the coil.

57. The anchor recited in Claim 56, wherein the shaft is adapted for removal by counter rotation of the coil outwardly of the abdominal wall.

1/15

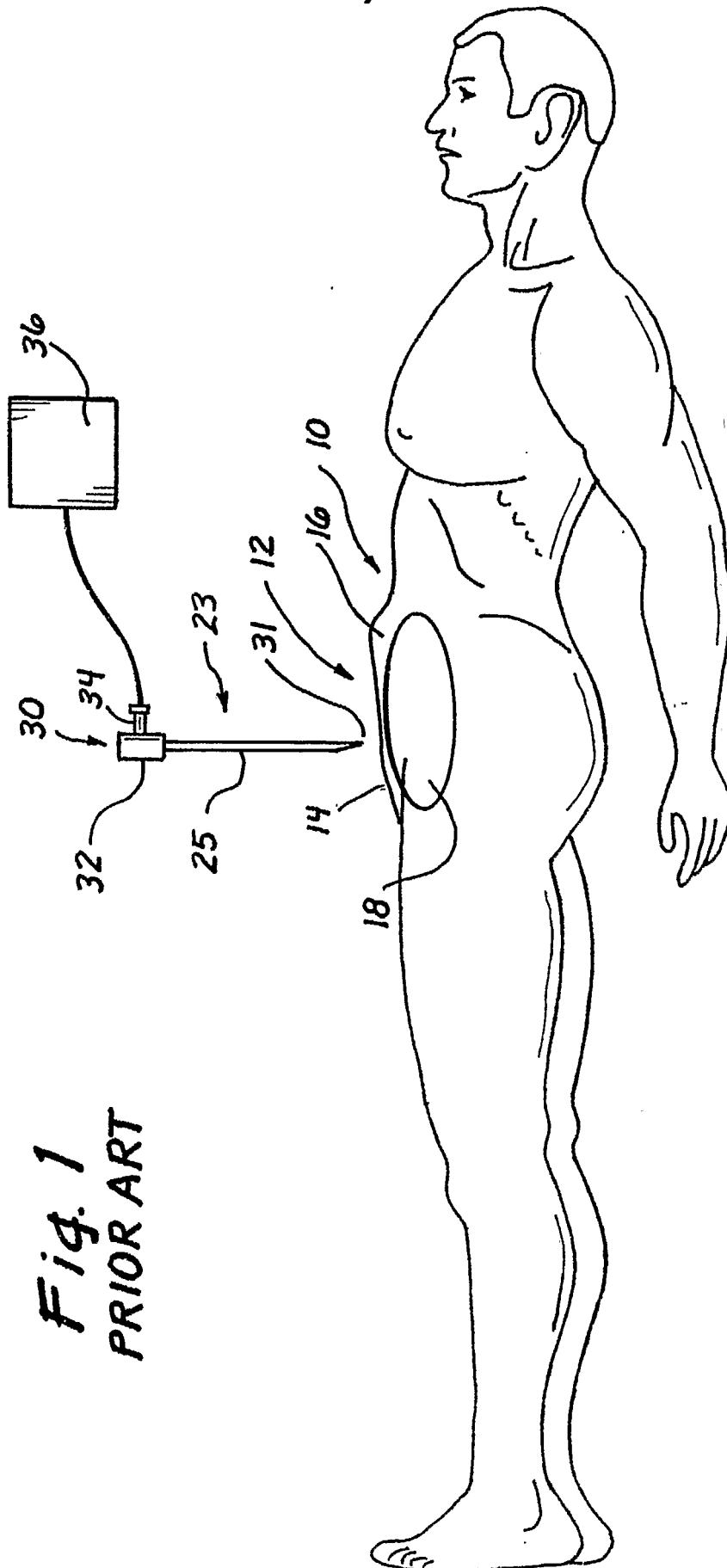
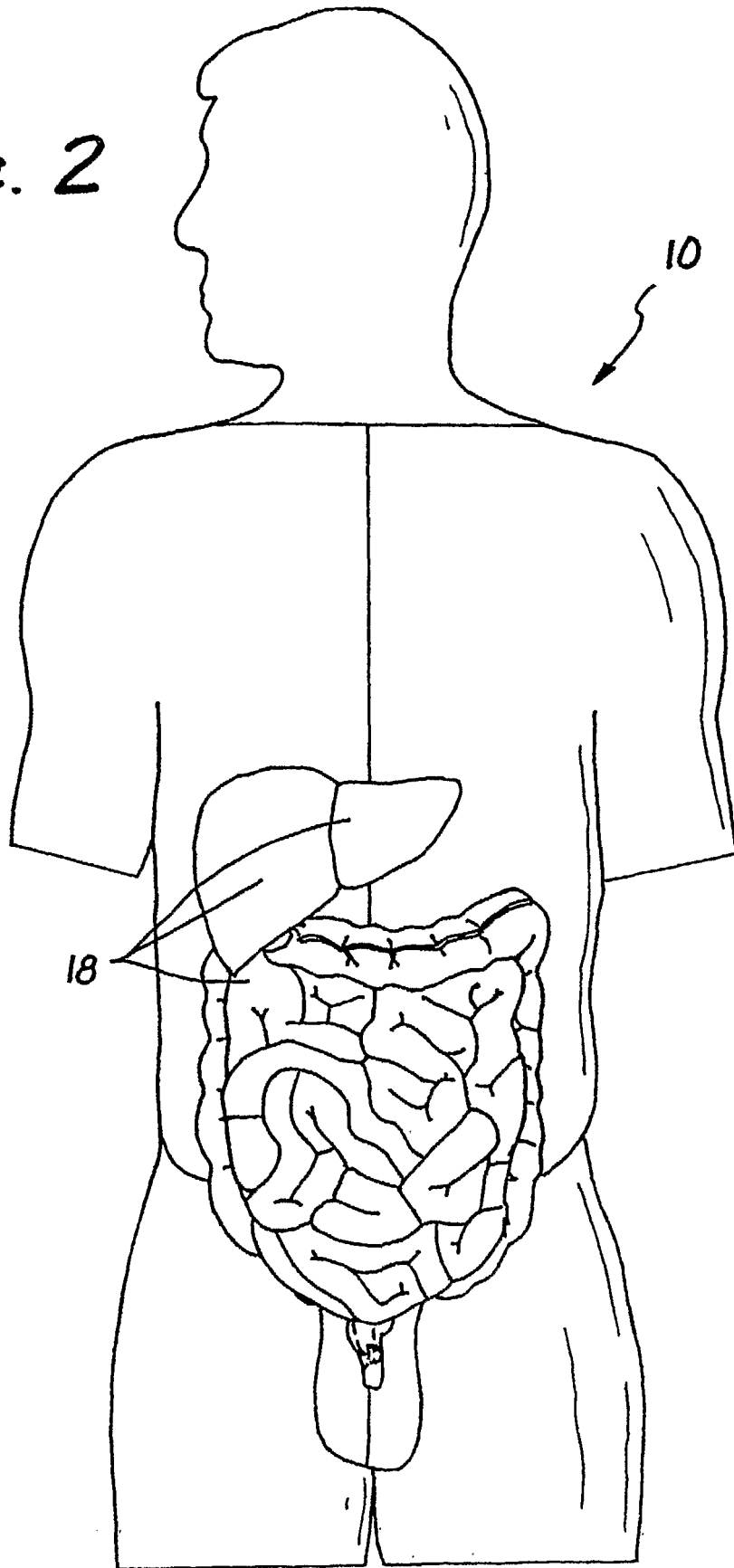

Fig. 1
PRIOR ART

2/15

Fig. 2



3/15

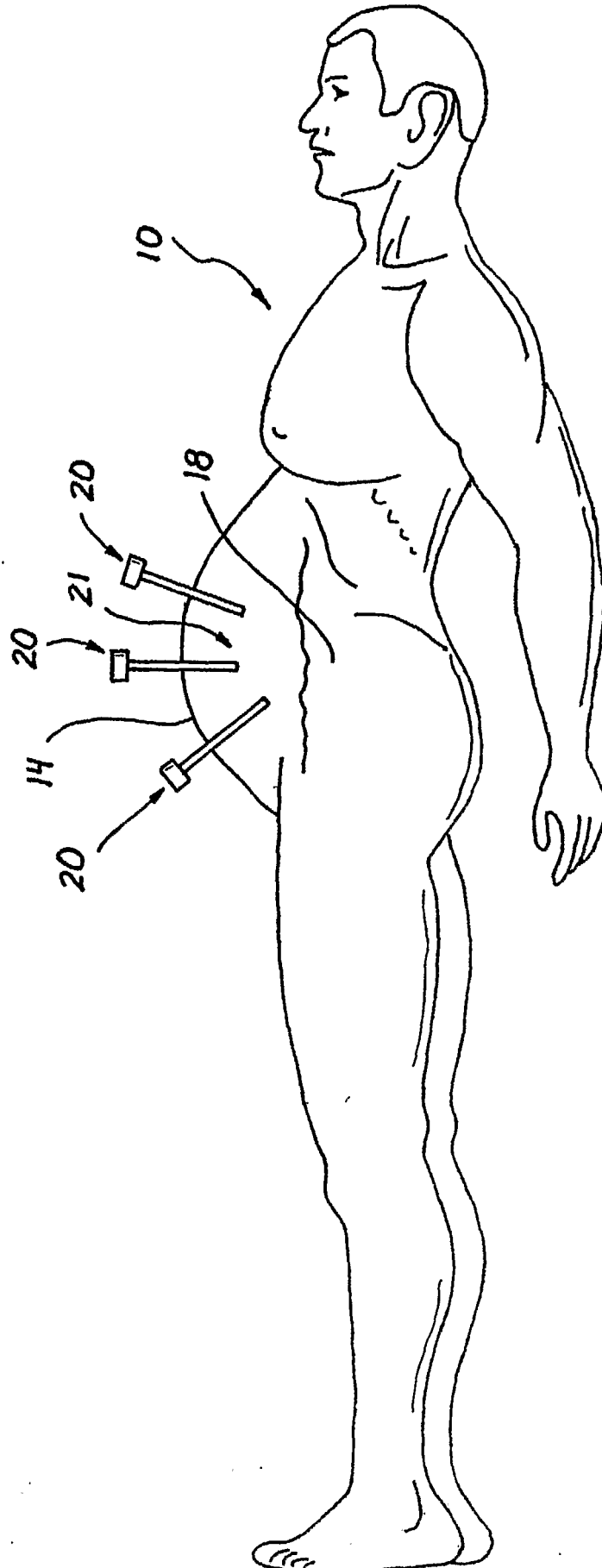

Fig. 3

4/15

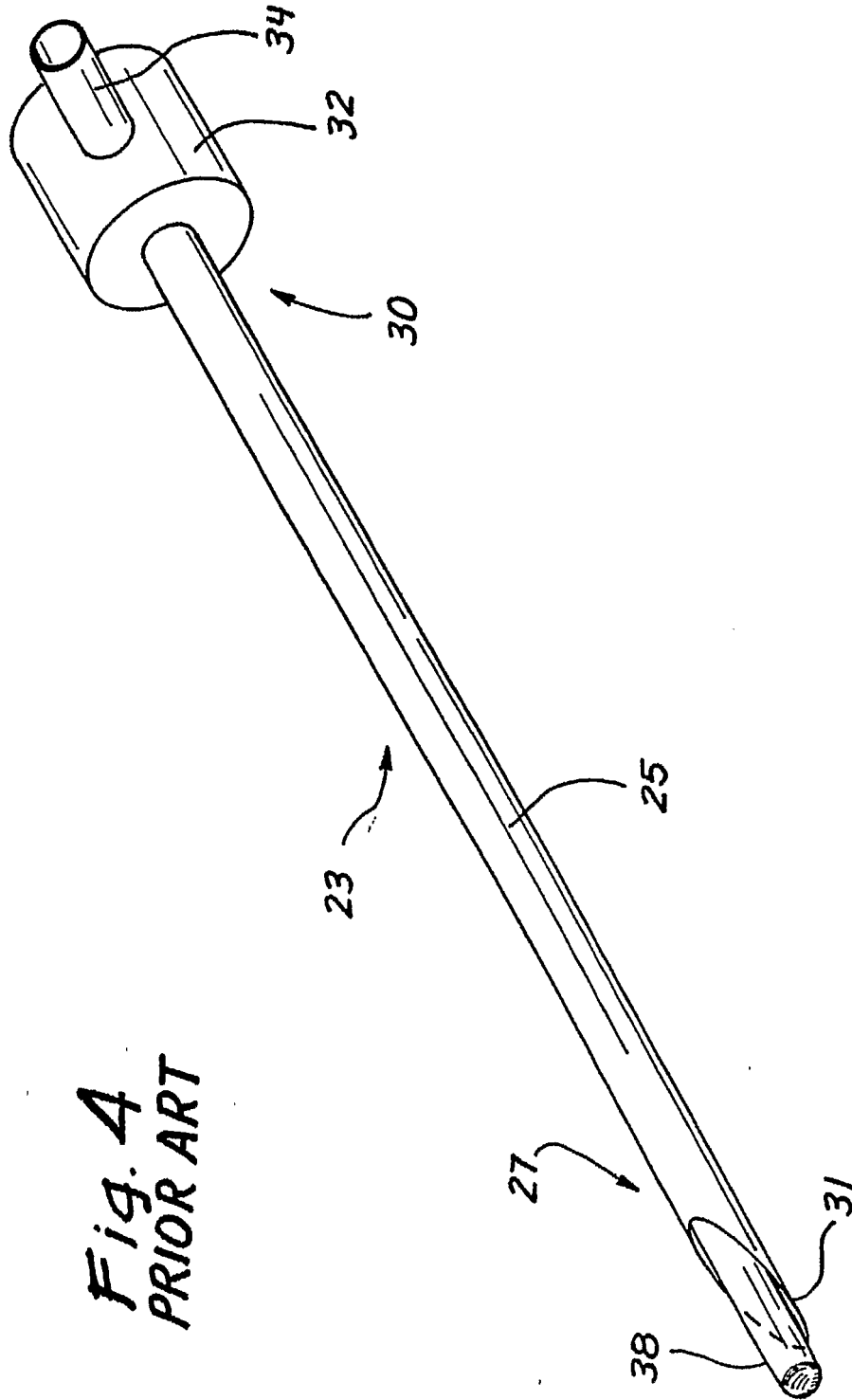

Fig. 4
PRIOR ART

5/15

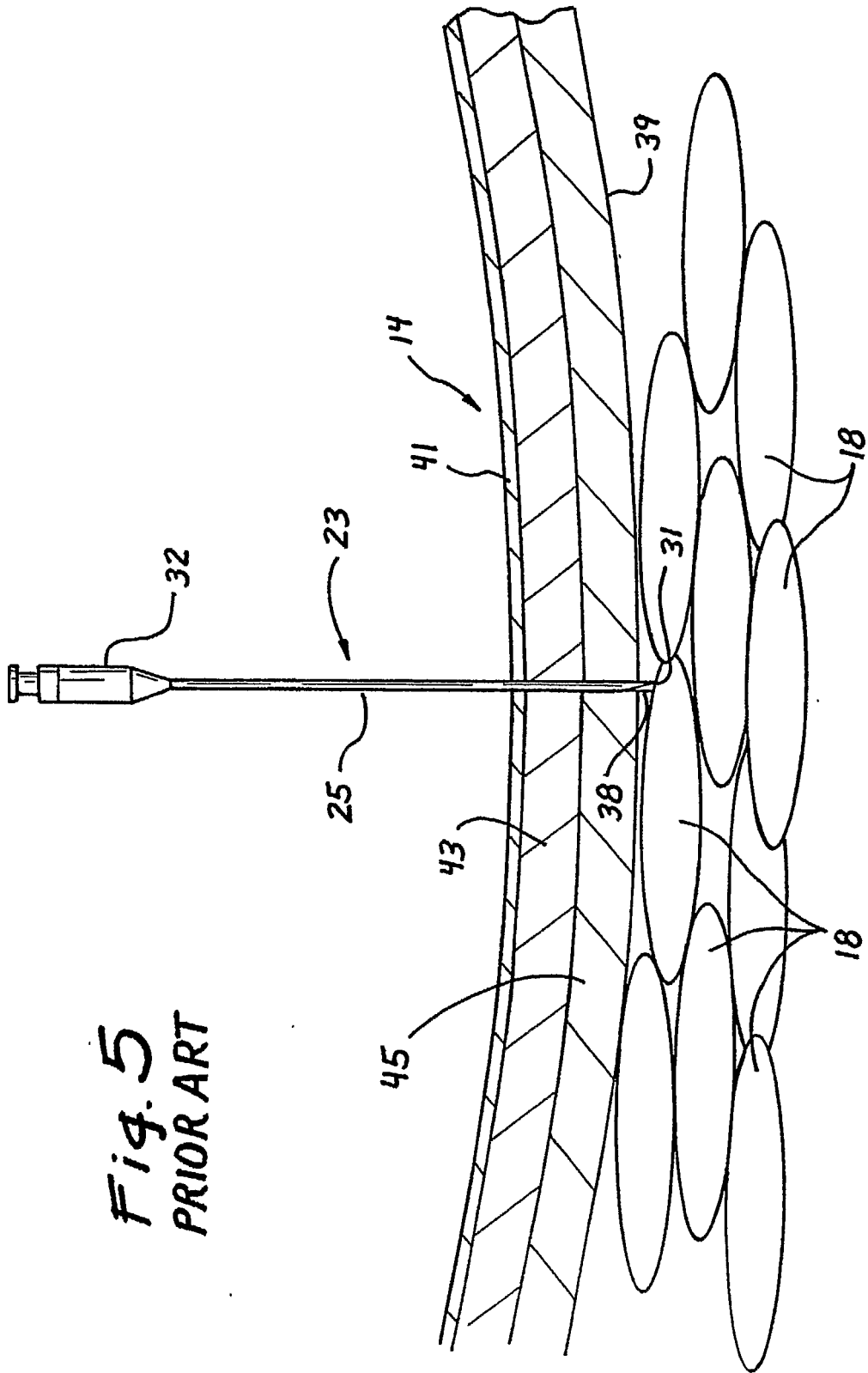
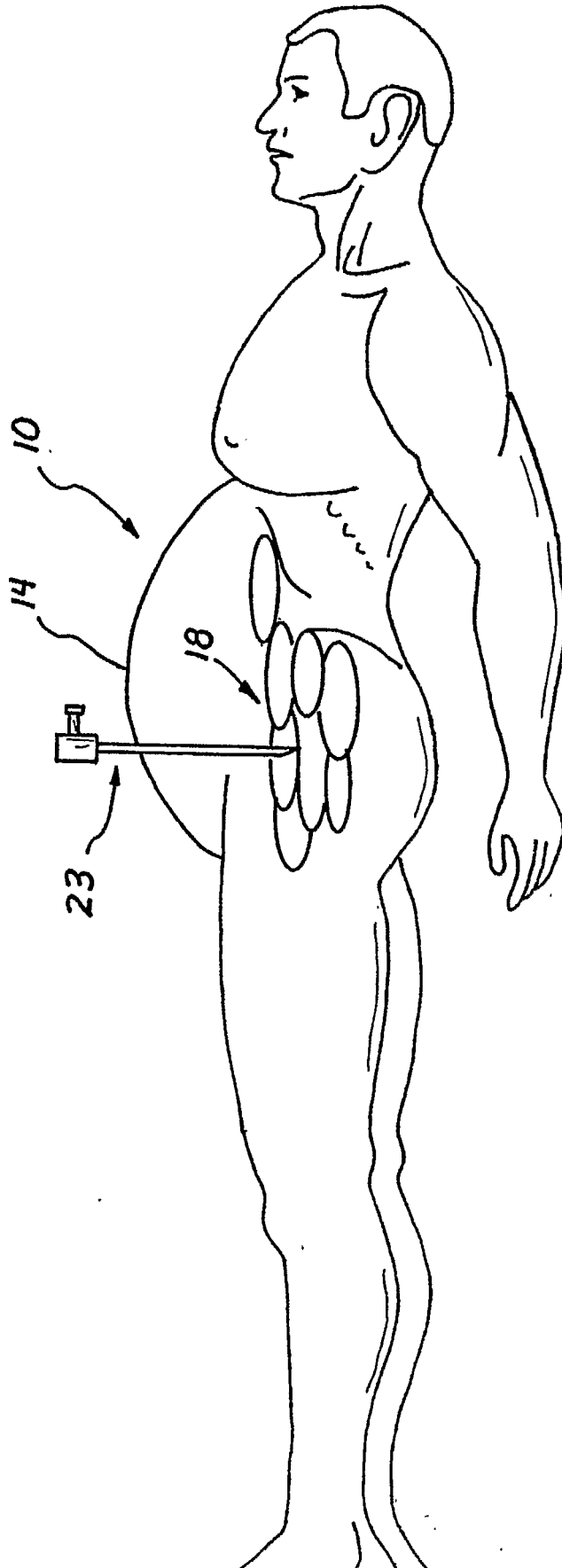

Fig. 5
PRIOR ART

6/15

Fig. 6
PRIOR ART



7/15

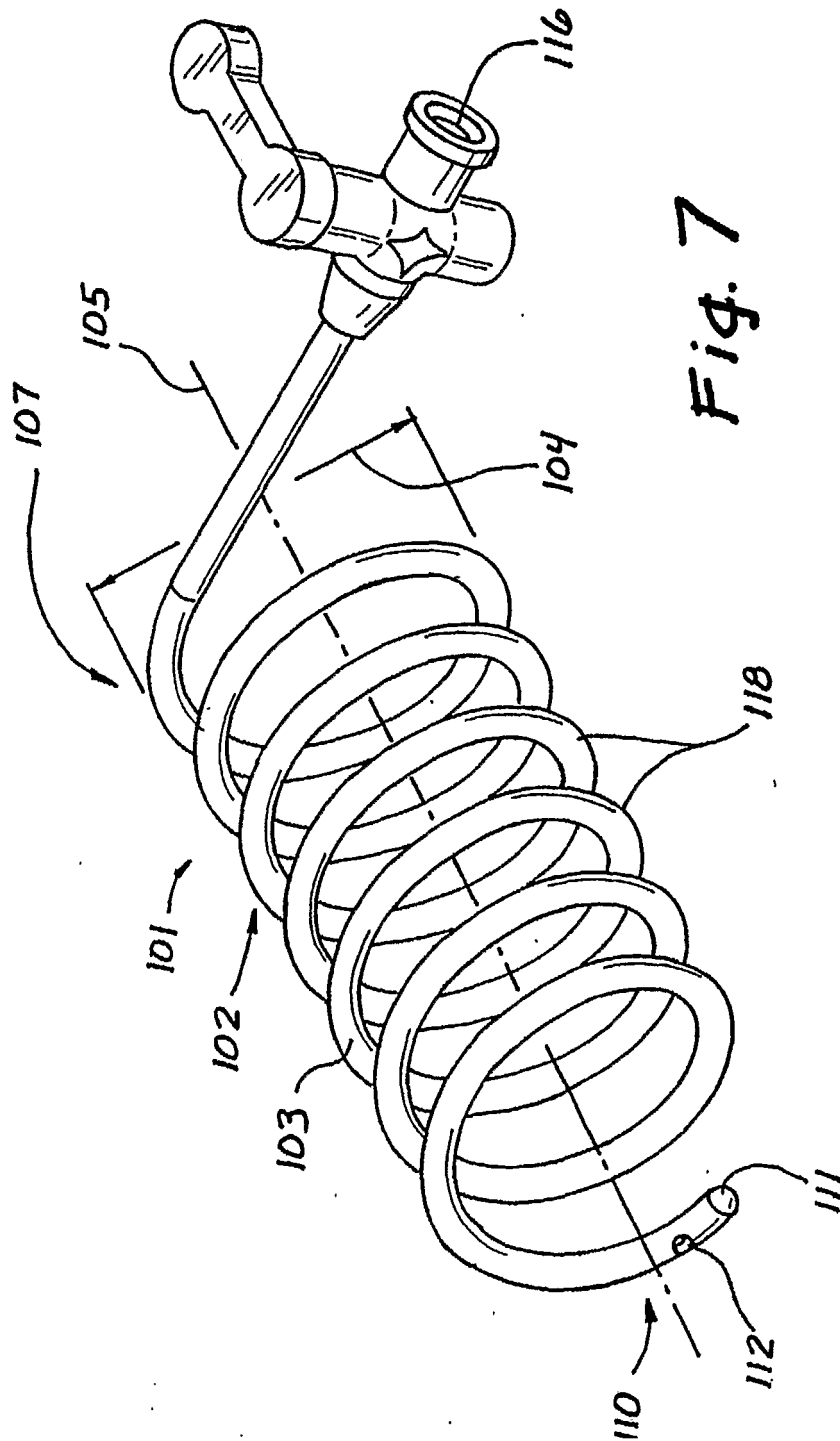

Fig. 7

8/15

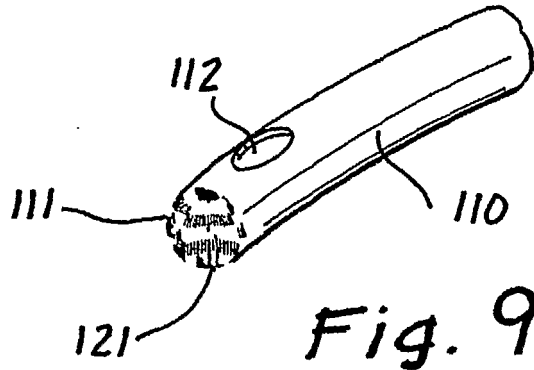

Fig. 9

Fig. 8

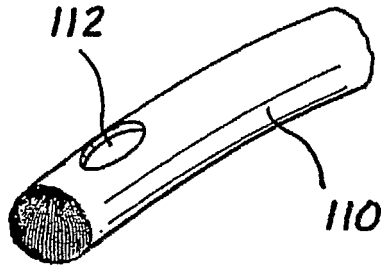

Fig. 11

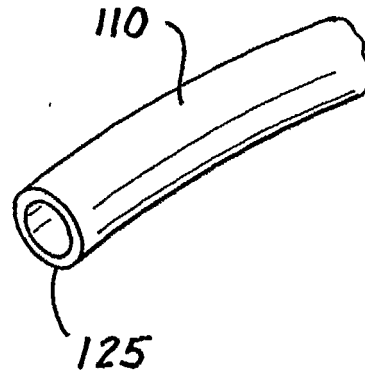
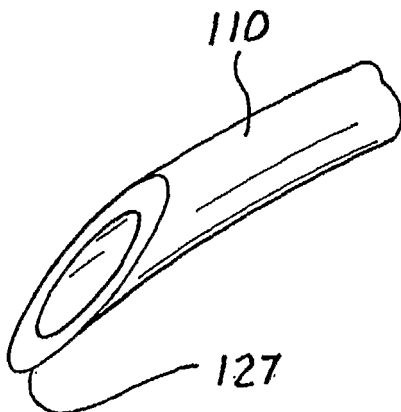
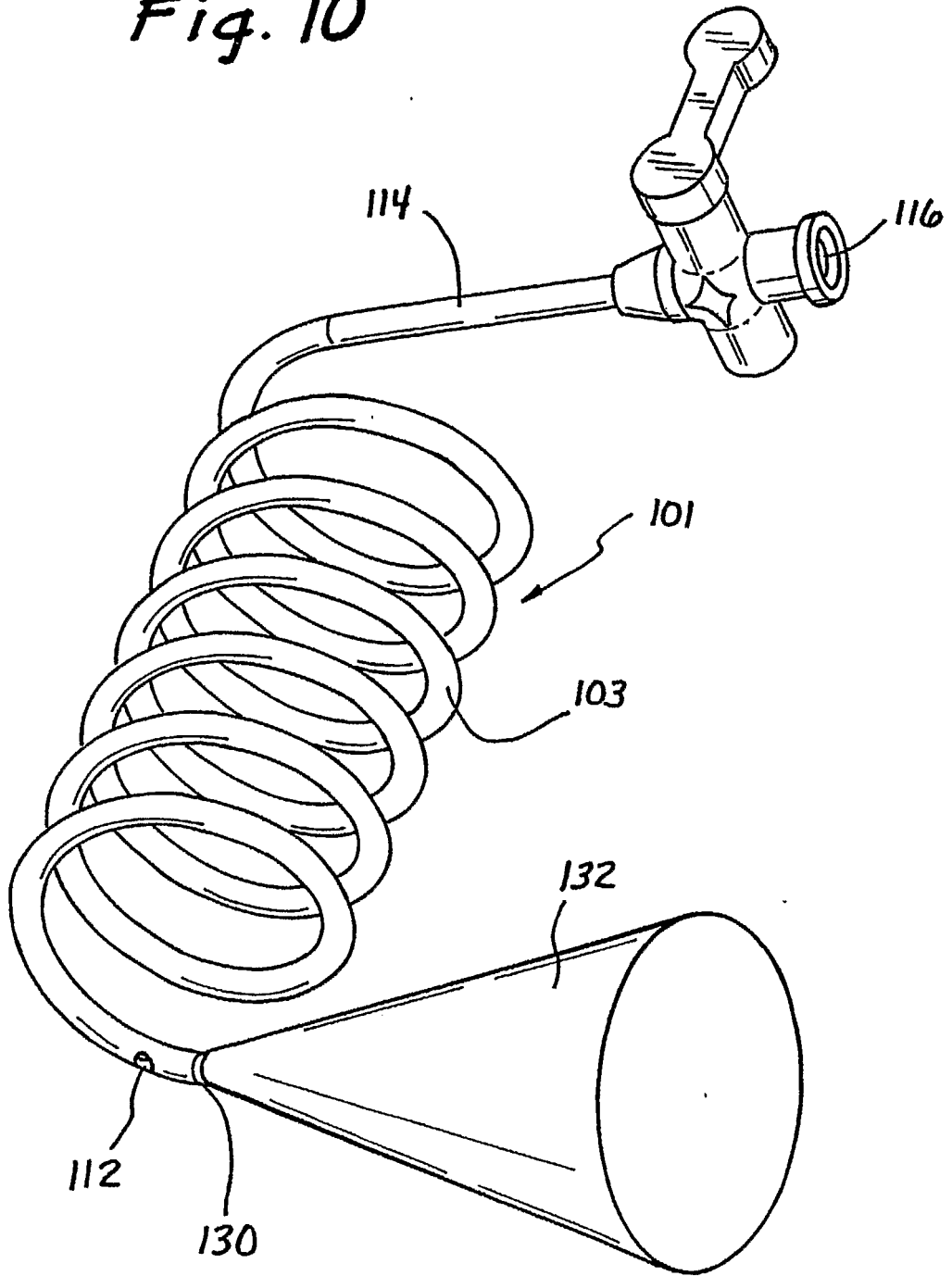

Fig. 12



9/15

Fig. 10



10/15

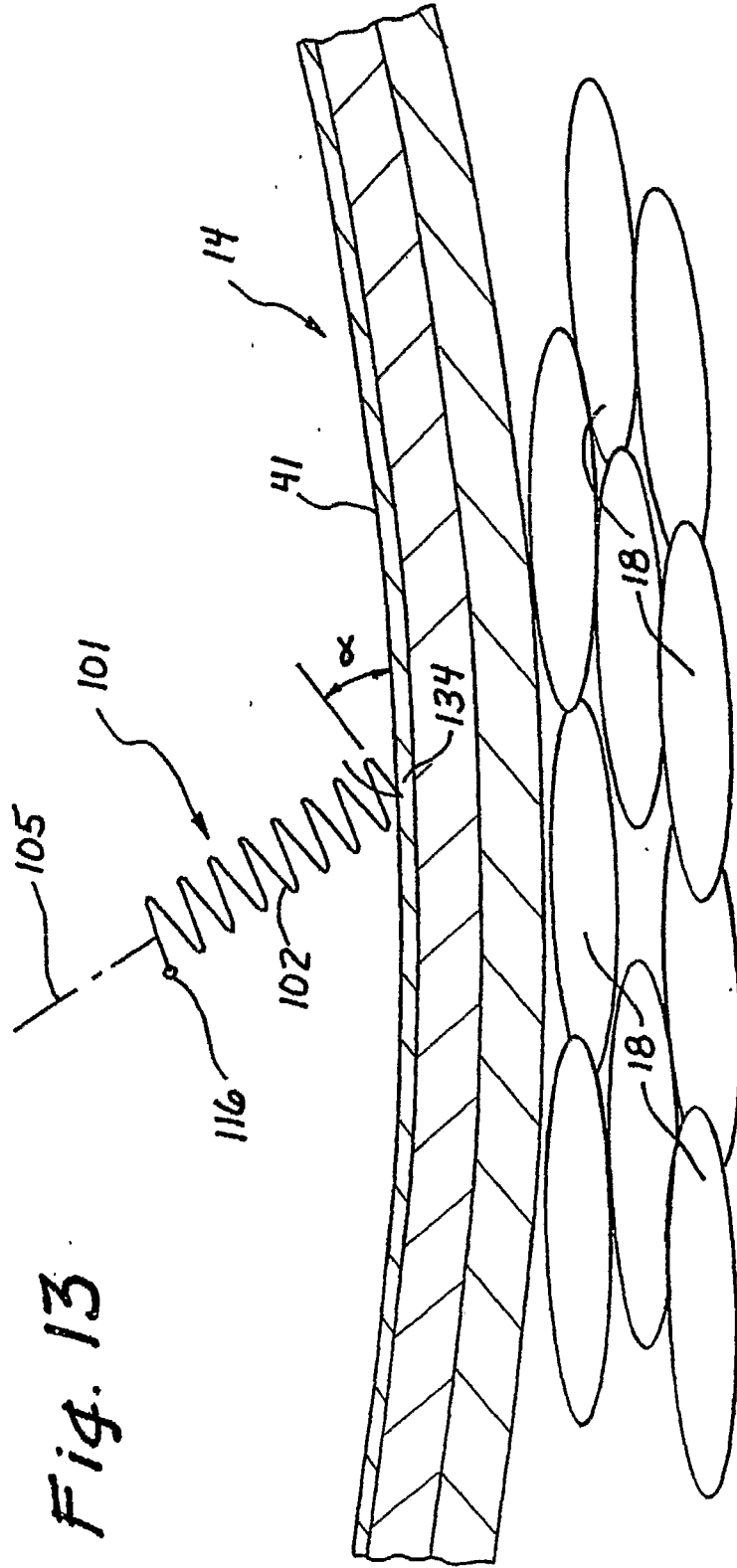

Fig. 13

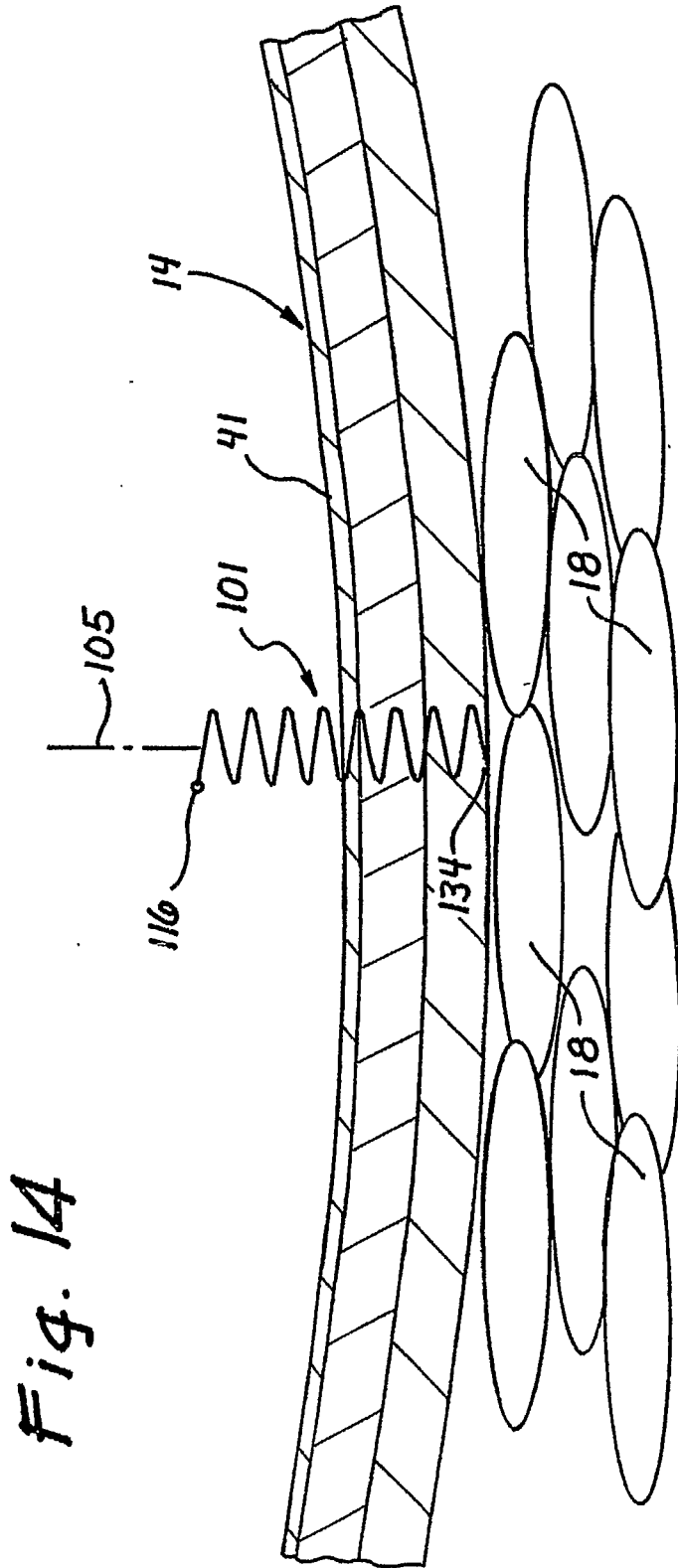

Fig. 14

12/15

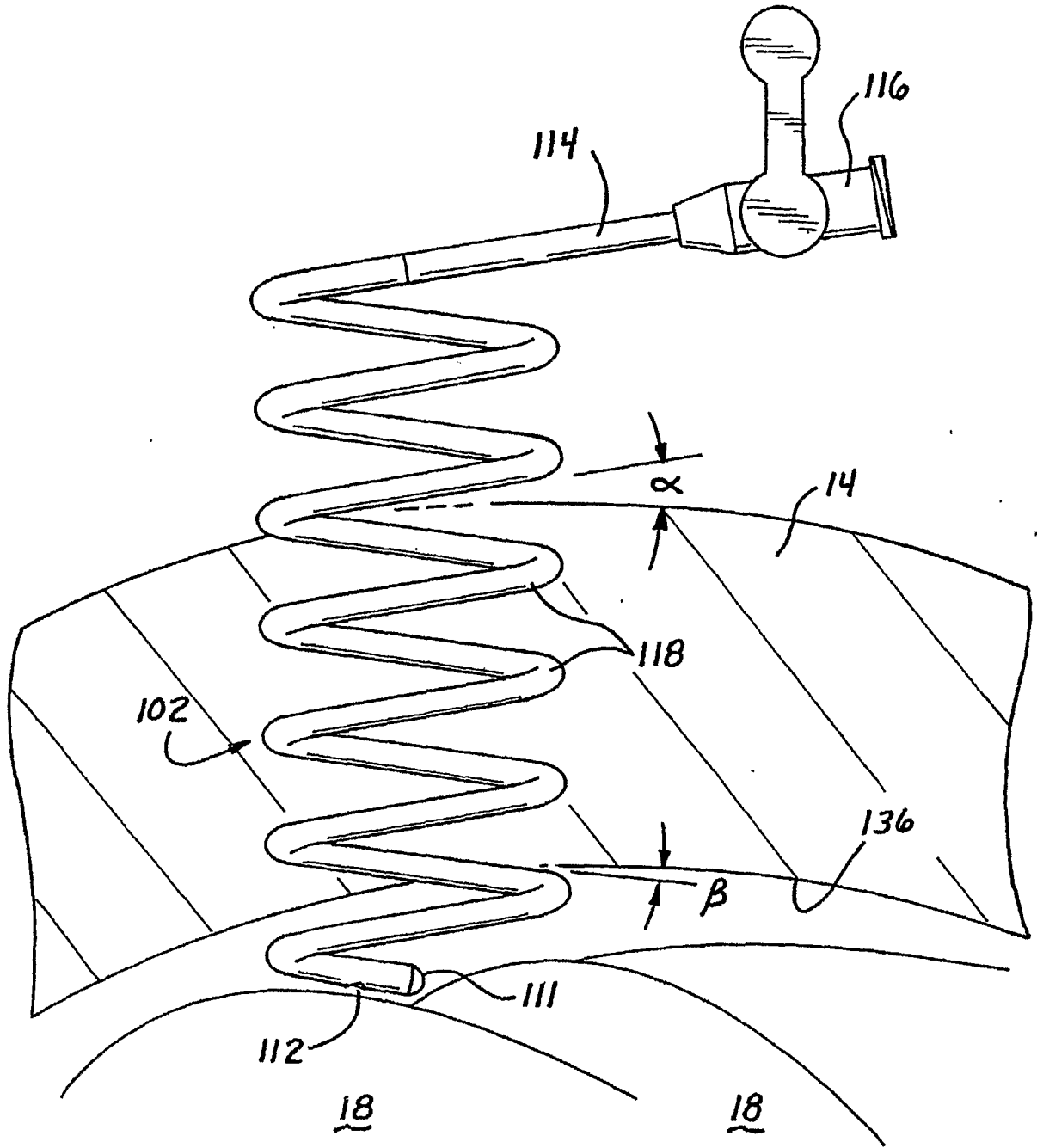

Fig. 15

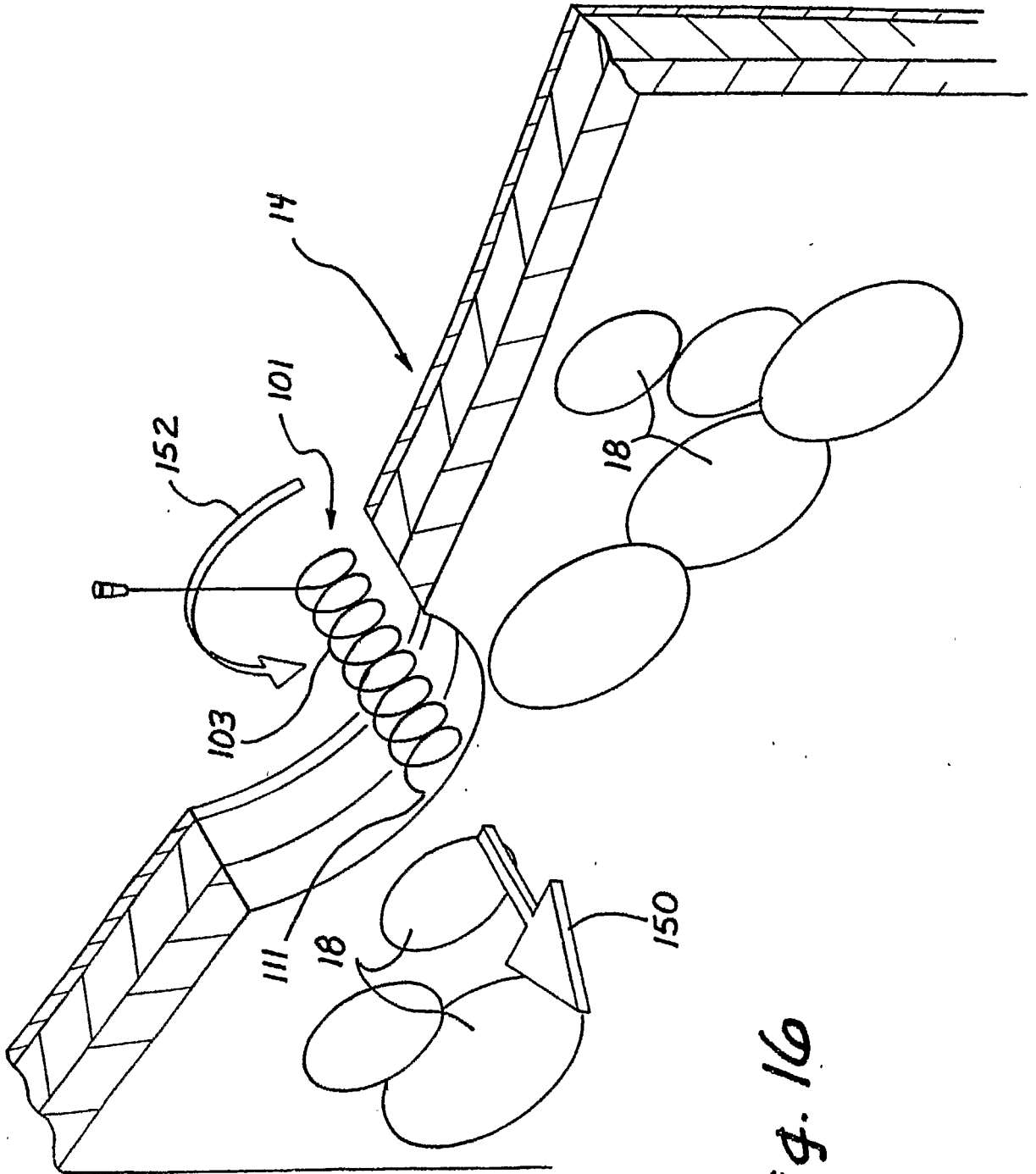

Fig. 16

14/15

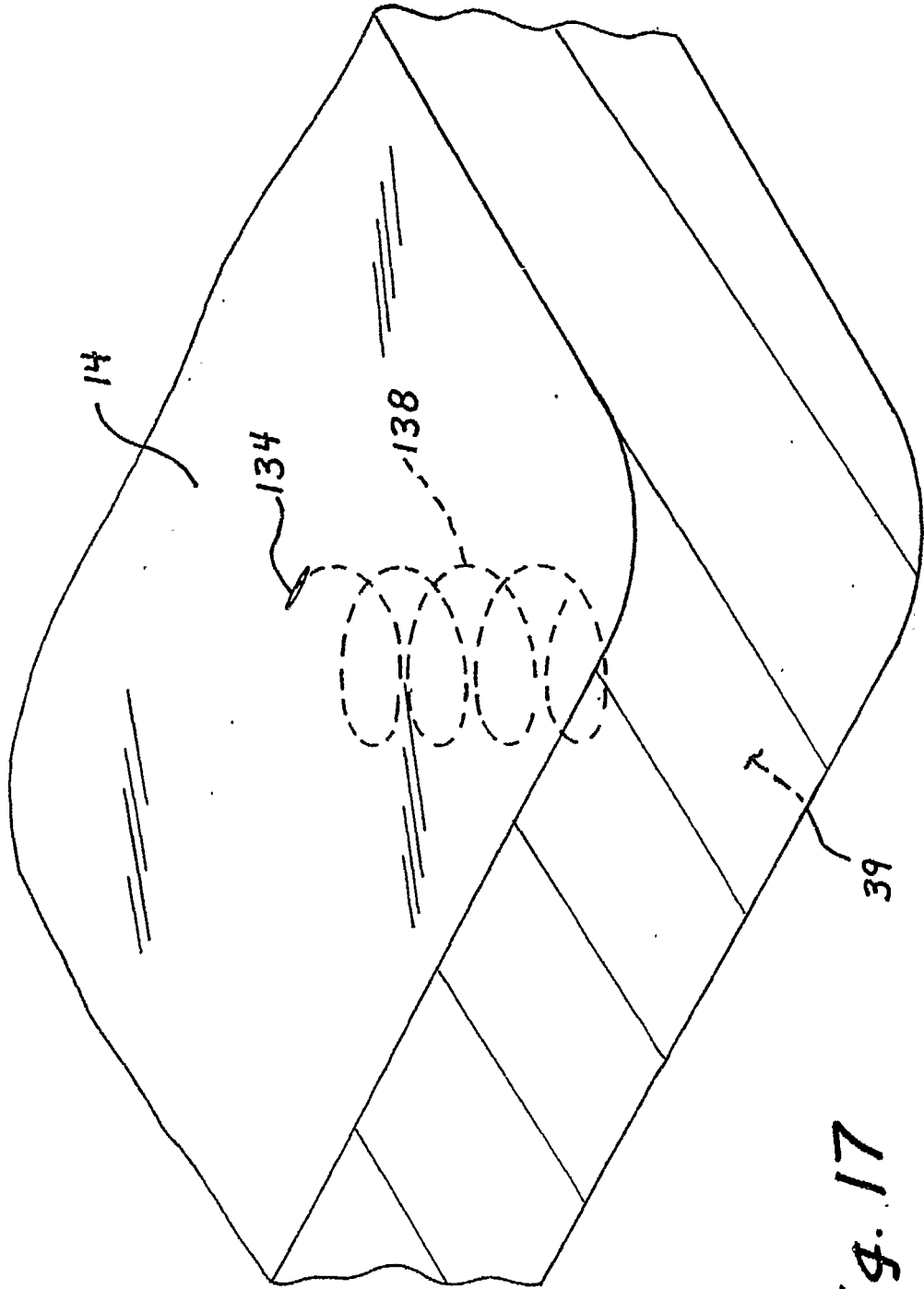

Fig. 17

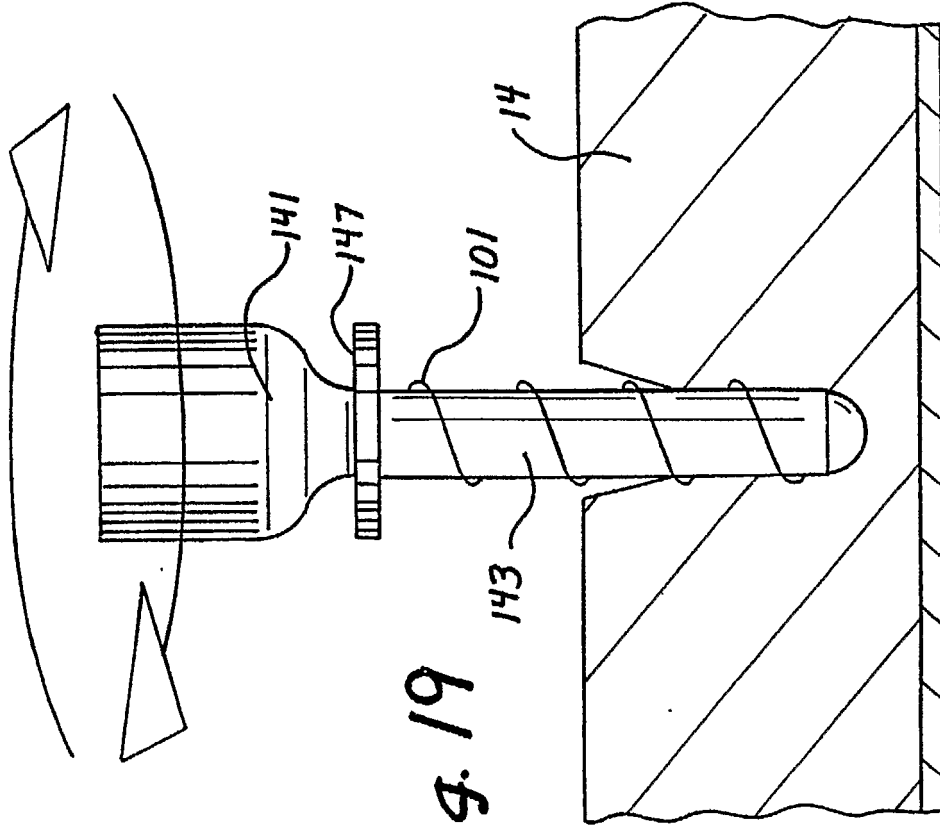

Fig. 19

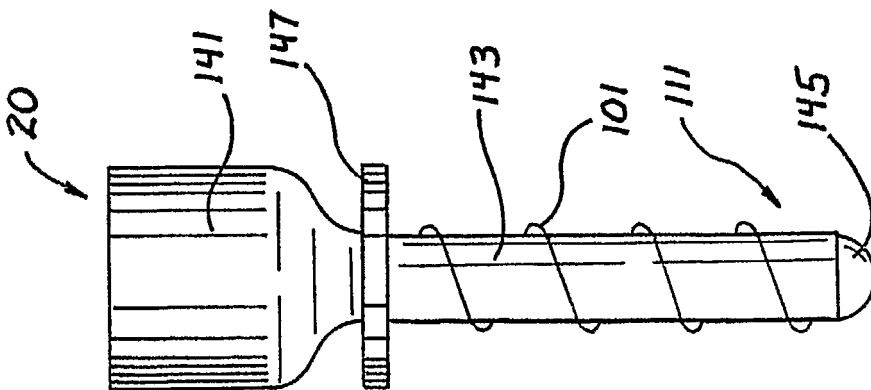

Fig. 18

专利名称(译)	手术进入装置和方法		
公开(公告)号	EP1594391A2	公开(公告)日	2005-11-16
申请号	EP2004701731	申请日	2004-01-13
[标]申请(专利权)人(译)	应用医疗资源		
申请(专利权)人(译)	应用医疗资源INC.		
当前申请(专利权)人(译)	应用医疗资源INC.		
[标]发明人	HART CHARLES C BRUSTAD JOHN R		
发明人	HART, CHARLES, C. BRUSTAD, JOHN, R.		
IPC分类号	A61B1/313 A61B17/32 A61B17/34 A61B19/00 A61B1/00		
CPC分类号	A61B17/3417 A61B1/3132 A61B17/3474 A61B90/30 A61B2017/320044 A61B2017/349 A61B2090/08021 A61B2090/373		
优先权	10/346846 2003-01-17 US		
其他公开文献	EP1594391A4		
外部链接	Espacenet		

摘要(译)

腹腔镜吹气装置设置在具有钝头的线圈的构造中。该装置能够在不切割组织的情况下穿过腹壁，并且基本上平行于内表面离开腹壁。当盘绕装置的旋转导致通过腹壁向前移动时，可以向装置施加反作用力以在壁和内部器官之间形成安全空间，具有钝的远端尖端，平行的出口角度和安全空间，在放置装置期间，对内部器官基本上没有威胁。通过使用加压气体可以产生进一步的空间，以产生用于随后放置套管针的腹腔。通过将盘绕的吹气装置可旋转地连接到套管针上，反作用力的优点不仅可用于建立安全空间，而且还可用于利用抵抗隆起的反作用力将套管针拉入腹壁。