

(19) World Intellectual Property Organization
International Bureau



(43) International Publication Date
15 February 2001 (15.02.2001)

PCT

(10) International Publication Number
WO 01/10289 A2

- (51) International Patent Classification⁷: **A61B 1/00**
- (21) International Application Number: PCT/GB00/03026
- (22) International Filing Date: 10 August 2000 (10.08.2000)
- (25) Filing Language: English
- (26) Publication Language: English
- (30) Priority Data:
9918703.1 10 August 1999 (10.08.1999) GB
- (71) Applicant (for all designated States except US): **G. SCOPE LIMITED** [GB/GB]; QUBIS Limited, 10 Malone Road, Belfast BT9 5BN (GB).
- (72) Inventors; and
- (75) Inventors/Applicants (for US only): **GALLAGHER, Anthony, Gerald** [GB/GB]; 15 Sycamore Drive, Jordantown, Belfast BT37 0AP (GB). **NEIL, William, John** [GB/GB]; 10 Malone Road, Belfast BT9 5BN (GB).
- (74) Agent: **MURGITROYD & COMPANY**; 373 Scotland Street, Glasgow G5 8QA (GB).
- (81) Designated States (national): AE, AG, AL, AM, AT, AU, AZ, BA, BB, BG, BR, BY, BZ, CA, CH, CN, CR, CU, CZ, DE, DK, DM, DZ, EE, ES, FI, GB, GD, GE, GH, GM, HR, HU, ID, IL, IN, IS, JP, KE, KG, KP, KR, KZ, LC, LK, LR, LS, LT, LU, LV, MA, MD, MG, MK, MN, MW, MX, MZ, NO, NZ, PL, PT, RO, RU, SD, SE, SG, SI, SK, SL, TJ, TM, TR, TT, TZ, UA, UG, US, UZ, VN, YU, ZA, ZW.
- (84) Designated States (regional): ARIPO patent (GH, GM, KE, LS, MW, MZ, SD, SL, SZ, TZ, UG, ZW), Eurasian patent (AM, AZ, BY, KG, KZ, MD, RU, TJ, TM), European patent (AT, BE, CH, CY, DE, DK, ES, FI, FR, GB, GR, IE, IT, LU, MC, NL, PT, SE), OAPI patent (BF, BJ, CF, CG, CI, CM, GA, GN, GW, ML, MR, NE, SN, TD, TG).
- Published:**
— Without international search report and to be republished upon receipt of that report.
- For two-letter codes and other abbreviations, refer to the "Guidance Notes on Codes and Abbreviations" appearing at the beginning of each regular issue of the PCT Gazette.



WO 01/10289 A2

(54) Title: SURGICAL CAMERA APPARATUS AND METHOD

(57) Abstract: A device adapted to receive a surgical camera useable in a patient and having means to detect rotational and/or longitudinal movement of a camera relative to a reference point in, on or about the patient is described. The reference point is preferably a surgical port means, and the device is preferably adapted to conjoin with the port means. By detecting and/or measuring any rotational and/or longitudinal measurement of the camera relative to a reference point, the surgeon can be made aware of desired or undesired movement of the camera during surgery as referenced to the reference point. Such information would be particularly useful in laparoscopic or endoscopic surgery.

1 Surgical Camera Apparatus and Method

2

3 The present invention relates to a device and method
4 for use with a surgical camera, particularly but not
5 exclusively a laparoscopic camera.

6

7 During certain forms of surgery, e.g. laparoscopic
8 surgery, a camera is used to provide vision for the
9 surgeon. However, the surgeon does not usually operate
10 the camera, such that he relies upon the co-ordination
11 of an assistant to control the movement and direction
12 of vision of the camera, whilst he conducts the
13 surgery. However, when conducting a laparoscopic
14 procedure with a manually held laparoscopic camera, the
15 assistant can easily allow the camera to 'drift'.
16 Accidental rotational drift is the commonest problem,
17 thereby leading to orientational error as the surgeon
18 attempts to maintain co-ordination of the monitored
19 display of camera information, with his own surgical
20 procedure.

1

2 It is an object of the present invention to provide
3 visual feedback to the surgical team by means of a
4 graphical display indicating additional positional
5 information of the laparoscopic camera relative to a
6 laparoscopic port and patient alignment. Such visual
7 data can be overlaid on the visual laparoscopic image.

8

9 According to one aspect of the present invention, there
10 is provided a device adapted to receive a surgical
11 camera useable in a patient and having means to detect
12 rotational and/or longitudinal movement of the camera
13 relative to a reference point in, on or about the
14 patient.

15

16 The device may also be able to measure any rotational
17 and/or longitudinal movement of the camera relative to
18 the reference point.

19

20 In one embodiment of the present invention, the
21 reference point is the or one of the surgical points of
22 entry into the patient, e.g. a surgical port means. By
23 detecting and/or measuring any rotational and/or
24 longitudinal measurement of the camera relative to a
25 reference point, e.g. the patient and/or a port, the
26 surgeon can be made aware of desired or undesired
27 movement of the camera as referenced to the patient
28 and/or the port.

29

30 The device may be integral with the camera and/or port,
31 or be formed as a separate unit adapted to be fitted to
32 or otherwise conjoin with known camera and port

1 apparatus. The device may be releasably conjoinable
2 therewith.

3

4 The detection means for use with the present invention
5 includes any suitable apparatus, device, means or unit
6 adapted to detect effective movement between two parts.
7 The means may involve any, or any combination of,
8 electrical, electromagnetic, optical and/or mechanical
9 apparatus, etc.

10

11 The detection means may include one or more sensor
12 means, such as an optical transmitter/receiver. The
13 sensor means may be able to detect camera movement
14 directly.

15

16 In one embodiment of the present invention, the
17 detection means includes intermediate means such as one
18 or more belts or rollers, or one or more cog wheels
19 such as a gear train, the movement of which relates to
20 movement of the camera relative to the patient. The
21 camera and/or any such intermediate means as described
22 herein before may be graded or graduated, the passage
23 of which is what is detected.

24

25 In another embodiment of the present invention, the
26 device includes a sleeve coaxial with a surgical port,
27 either therewithin or therewithout, and movement of the
28 sleeve is proportional to the rotational and/or
29 longitudinal movement of the camera relative to the
30 port.

31

1 According to a further embodiment of the present
2 invention, the device includes control means, encoder
3 means and/or information relay means. Preferably
4 relative-motion information from the device can be
5 relayed to a visual display unit, e.g. the existing
6 visual display means showing the surgical e.g.
7 laparoscopic image from the camera.

8

9 The device of the present invention may also include a
10 visual and/or audible alarm means or alarm-initiator
11 means adapted to provide a visual and/or audible alarm
12 signal in the event of an undesired and/or (possibly)
13 predetermined rotational and/or longitudinal movement
14 of the camera relative to the port being detected.

15

16 The device of the present invention can be constructed
17 and made to any suitable size, shape and design. In
18 one embodiment, the device can be made sufficiently
19 simply to be disposable. The device is usable in any
20 form of surgery using a camera, e.g. laparoscopy and
21 endoscopy.

22

23 According to a second aspect of the present invention,
24 there is provided a method to detect rotational and/or
25 longitudinal movement of a surgical camera useable in a
26 patient relative to a reference point in, on or about
27 the patient, wherein a device as defined herein before
28 is conjoined with the camera in use and detects the
29 relative movement.

30

31 Preferably, there is a method of detecting and/or
32 measuring rotational and/or longitudinal movement of a

1 camera relative to a surgical port means, wherein the
2 device is adapted to mate with the camera and the port
3 has means adapted to measure and/or detect such
4 movement. Part of the camera is preferably inserted
5 through the device in use.

6

7 Embodiments of the present invention will now be
8 described by way of example and in relation to the
9 accompanying diagrammatic drawings in which:

10

11 Fig 1 is a perspective view of a device according to
12 one embodiment of the present invention;

13

14 Fig 2 is a perspective view of the device in Fig 1,
15 with mating camera and laparoscopic port;

16

17 Fig 3 is a perspective view of a device according to a
18 second embodiment of the present invention;

19

20 Fig 4 is a perspective view of the internal workings of
21 the device shown in Fig 3;

22

23 Figs 5a and 5b are top and side views of the means
24 shown in Fig 4;

25

26 Fig 6 is a side view of a device according to a third
27 embodiment of the present invention with attached port
28 and camera;

29

30 Fig 7 is a perspective view of parts of a device
31 according to a fourth embodiment of the present
32 invention;

1

2 Fig 8 shows a schematic perspective view of parts of a
3 device according to a fifth embodiment of the present
4 invention;

5

6 Fig 9 shows a schematic view of a visual data display
7 having on-screen graphics provided from information
8 from a device of the present invention;

9

10 Fig 10 is a schematic flow diagram of analysis of
11 information from means of the present invention.

12

13 Referring to the drawings, Figure 1 shows a general
14 device 2 according to one embodiment of the present
15 invention. Fig 2 shows a general laparoscopic port 1
16 which can be inserted into a patient, and is designed
17 for use with for example a trocar. Attached to the
18 port 1 is the device 2, and attached to the device 2 is
19 a general laparoscopic camera 3.

20

21 Figure 3 shows a second general device 4 according to
22 the present invention, whose internal mechanism is
23 shown in Figures 4, 5a and 5b. As shown in these
24 Figures, the primary drive of the laparoscopic camera
25 device 4 is manual. A laparoscope (not shown) is
26 inserted into the orifice 6, and this orifice 6 also
27 forms the gaiter 8, which provides frictional
28 rotational drive for the laparoscopic camera control
29 system. The gaiter 8 is bonded to the primary wheel 12
30 of a gear train mechanism. The gear train mechanism is
31 mounted on an internal chassis 13. The gear train
32 mechanism provides transmission of rotary movement of

1 the camera to a 180-impulses incremental disk 14. The
2 rotational movement of this reflective disk 14 is
3 sensed or detected by an optical transmitter/receiver
4 16 (Figure 5b) which is mounted on a printed circuit
5 board 18. These components are also assembled on the
6 internal chassis 13.

7

8 Electronic signals are transmitted via lead 20 to an
9 information processing device (not shown) which
10 provides software graphic and display and data
11 recording.

12

13 The information from the device 4 is preferably
14 electronically conditioned to provide signals
15 appropriate for interfacing to a computer. The
16 computer preferably provides a textual and graphical
17 display, and permits the surgeon to:

18

- 19 1. Set up a datum cursor to his preferred angle of
20 view of the laparoscopic camera display.
- 21
- 22 2. Activate a dynamic cursor driven by the
23 laparoscopic camera rotation.
- 24
- 25 3. Observe any deviation of the dynamic cursor from
26 the datum cursor. An audible alarm is sounded
27 outside the angular tolerance set by the operator.

28

29 The visual display could be superimposed on the
30 laparoscopic video image of the surgical procedure
31 thereby providing an "artificial horizon". An example
32 of this is shown in Fig 9.

1 Fig 6 shows a third device 22 according to the present
2 invention. The device 22 is around a laparoscopic port
3 23. The device 22 has a frame 26 supporting a sleeve
4 24, camera mating part 25 and a shaft 28. On the shaft
5 28 is a stator 30 and encoder 32. Around the stator 30
6 and a bush 31 at the top of the sleeve 24 is an
7 intermediate mechanical drive belt pulley 34. Attached
8 to the encoder 32 is a connector 36, again connectable
9 to an information relay means, e.g. a lead to a
10 computer and/or a visual display means.

11

12 In use, the device 22 is attached to the port 23 after
13 the port 23 has been inserted into the patient. A
14 laparoscopic camera or laparoscope 40 is then inserted
15 into the mating part 25, and the optics are guided
16 through the sleeve part 24. The camera 40 and sleeve
17 24 can be mated using any suitable means, e.g. through
18 friction or a pin and slot arrangement, to rotate
19 together. Thus, any rotational movement of the camera
20 40 in use will also cause rotation of the sleeve 24 and
21 the bush 31, and, as a consequence, rotation of the
22 pulley belt 34 and stator 30. This motion of the
23 stator 30 can be detected by the encoder 32, and the
24 information relayed via the connector 36 to the visual
25 display means. The encoder 32 may also be able to
26 measure the degree of rotational movement, which
27 information could also be suitably relayed.

28

29 Fig 7 shows schematic means for a possible fourth
30 device according to the present invention, using a
31 toothed wheel 44 journalled on a sleeve part or a
32 camera shaft 46, with associated optical reading

1 device and chip 48 able to provide a direct reading
2 of movement of the wheel 44. Alternatively there is
3 a graded bar alongside the camera shaft 46, or the
4 camera shaft 46 itself is graded, and the
5 longitudinal movement of the shaft 46 is readable by
6 an optical reading device.

7

8 Fig 8 shows schematic means for another possible
9 device, using the arrangement of the device shown in
10 Fig 7, with additional longitudinal motion detecting
11 means based on a frictioned wheel 50 on a sleeve 52.
12 The wheel 50 is set to rotate upon longitudinal
13 movement of the sleeve etc 52, and relate its
14 movement to another toothed wheel 54, thereby
15 providing both rotational and longitudinal movement
16 detection and/or measurement. The longitudinal means
17 could act directly on the shaft of a laparoscope or
18 other camera.

19

20 The present invention provides an important advance
21 in assisting surgeons in endoscopic and laparoscopic
22 surgery to maintain visual understanding of the in
23 situ surgical procedure. Such visual understanding
24 is very dependent upon the position of the camera,
25 which is then dependent upon the handling ability of
26 the human camera operator. The present invention
27 allows the surgeon to maintain and track camera
28 movement with the position of his surgical
29 instruments with considerably more control.

30

1 CLAIMS

2

3 1. A device adapted to receive a surgical camera
4 usable in a patient and having means to detect
5 rotational and/or longitudinal movement of the
6 camera relative to a reference point in, on or
7 about the patient.

8

9 2. A device as claimed in Claim 1 wherein the means
10 is also able to measure the rotational and/or
11 longitudinal movement of the camera.

12

13 3. A device as claimed in Claim 1 or Claim 2
14 wherein the reference point is the or one of the
15 surgical points of entry into the patient.

16

17 4. A device as claimed in any one of Claims 1 to 3
18 wherein the reference point is a surgical port
19 means.

20

21 5. A device as claimed in Claim 4 wherein the
22 device is adapted to conjoin with the port
23 means.

24

25 6. A device as claimed in Claim 5 wherein the
26 device is adapted to releasably conjoin with the
27 port.

28

29 7. A device as claimed in Claim 4 wherein the
30 device is integral with the port.

31

- 1 8. A device as claimed in any one of the preceding
2 claims wherein the device includes a friction
3 fitting through which the camera or a part of
4 the camera is insertable.
5
- 6 9. A device as claimed in any one of the preceding
7 claims wherein the detection means includes one
8 or more sensor means.
9
- 10 10. A device as in claimed in Claim 9 wherein the
11 sensor means is an optical transmitter/
12 receiver.
13
- 14 11. A device as in claimed in Claim 9 or Claim 10
15 wherein the sensor means is adapted to directly
16 detect movement of the camera.
17
- 18 12. A device as claimed in any one of Claims 9 to 11
19 wherein the detection means includes one or more
20 intermediate means adapted to relay movement of
21 the camera to the or each sensor means.
22
- 23 13. A device as claimed in Claim 12 wherein the
24 intermediate means comprises a gear train
25 mechanism.
26
- 27 14. A device as claimed in any one of the preceding
28 claims wherein the camera and/or the
29 intermediate means are angularly and/or
30 longitudinally graded or graduated.
31

- 1 15. A device as claimed in any one of the preceding
2 claims wherein the device includes one or more
3 of the following: control means, encoder means
4 and information relay means.
5
- 6 16. A device as claimed in any one of the preceding
7 claims wherein the device is connectable to a
8 visual display unit.
9
- 10 17. A device as claimed in any one of the preceding
11 claims wherein the device includes a visual
12 and/or audible alarms means.
13
- 14 18. A device as in claimed in any one of the
15 preceding claims for use in laparoscopic or
16 endoscopic surgery.
17
- 18 19. A method to detect rotational and/or
19 longitudinal movement of a surgical camera
20 useable in a patient relative to a reference
21 point in, on or about the patient, wherein a
22 device as defined in any one of Claims 1 to 18
23 is conjoined with the camera in use and detects
24 the relative movement.
25
- 26 20. A method as claimed in Claim 19 wherein the
27 device is also able to measure rotational and/or
28 longitudinal movement of the camera.
29
- 30 21. A method as in claimed in Claim 19 or Claim 20
31 wherein the device is conjoined with a surgical

1 port means.

2

3 22. A method as claimed in any one or Claims 19 to
4 21 wherein the camera is inserted through the
5 device.

6

7 23. A laparoscopic device substantially as herein
8 described and with reference to Figures 1-8.

9

1 / 9

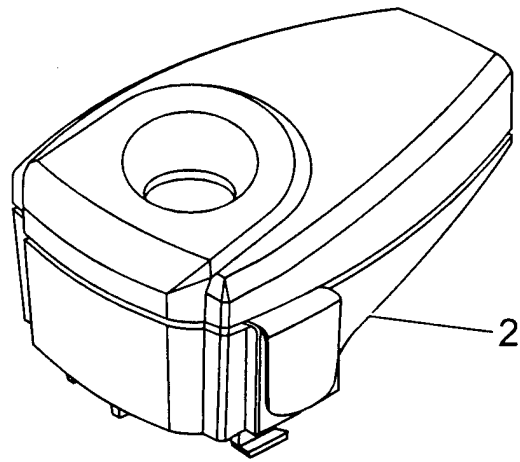

Fig. 1

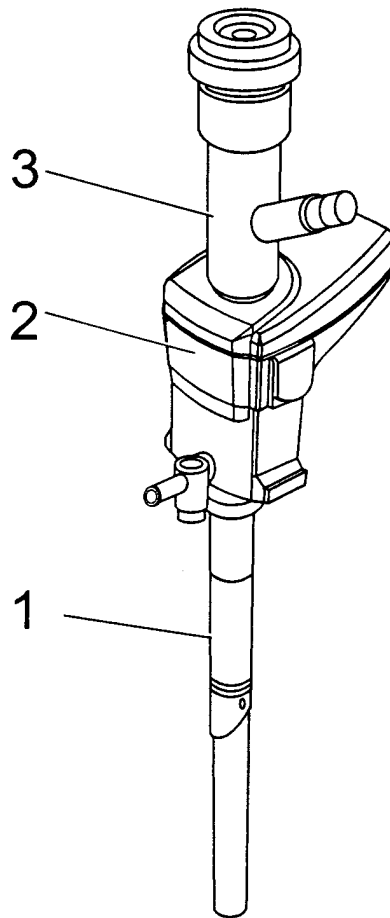

Fig. 2

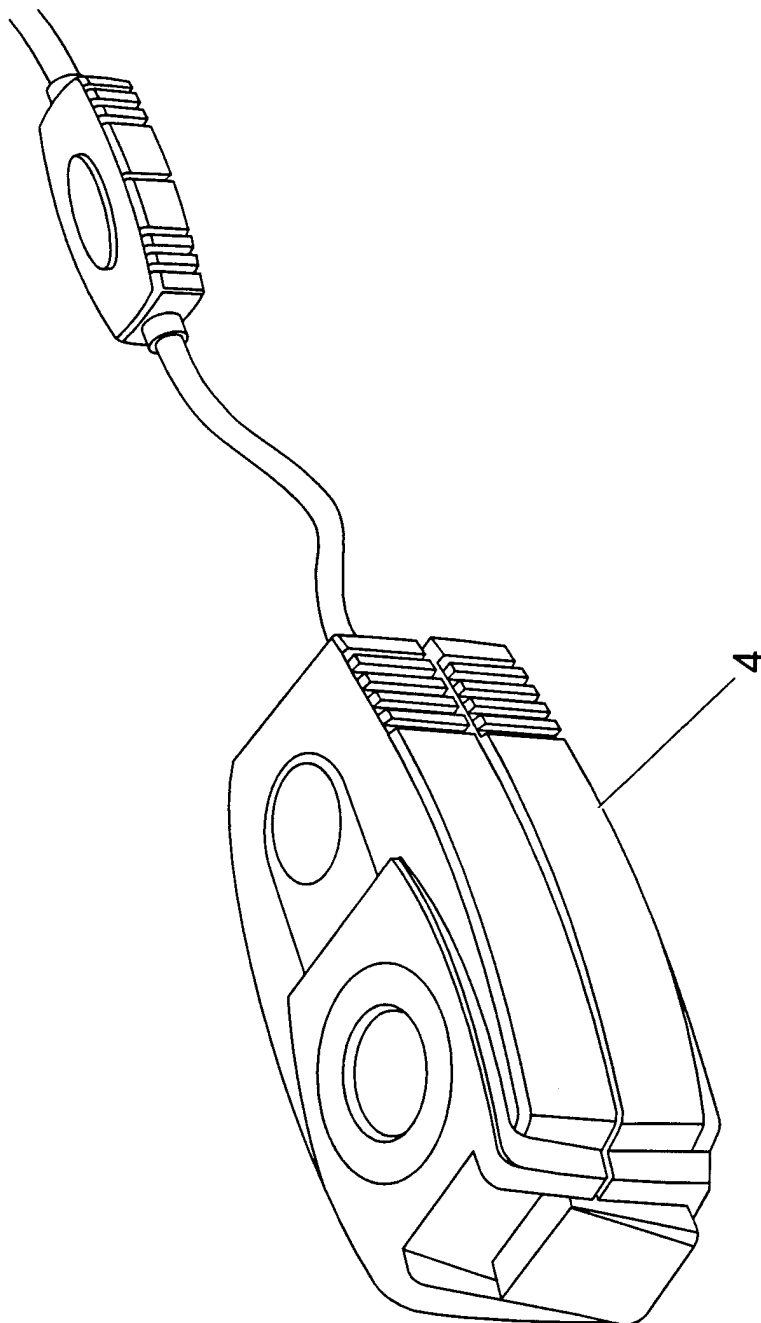

Fig. 3

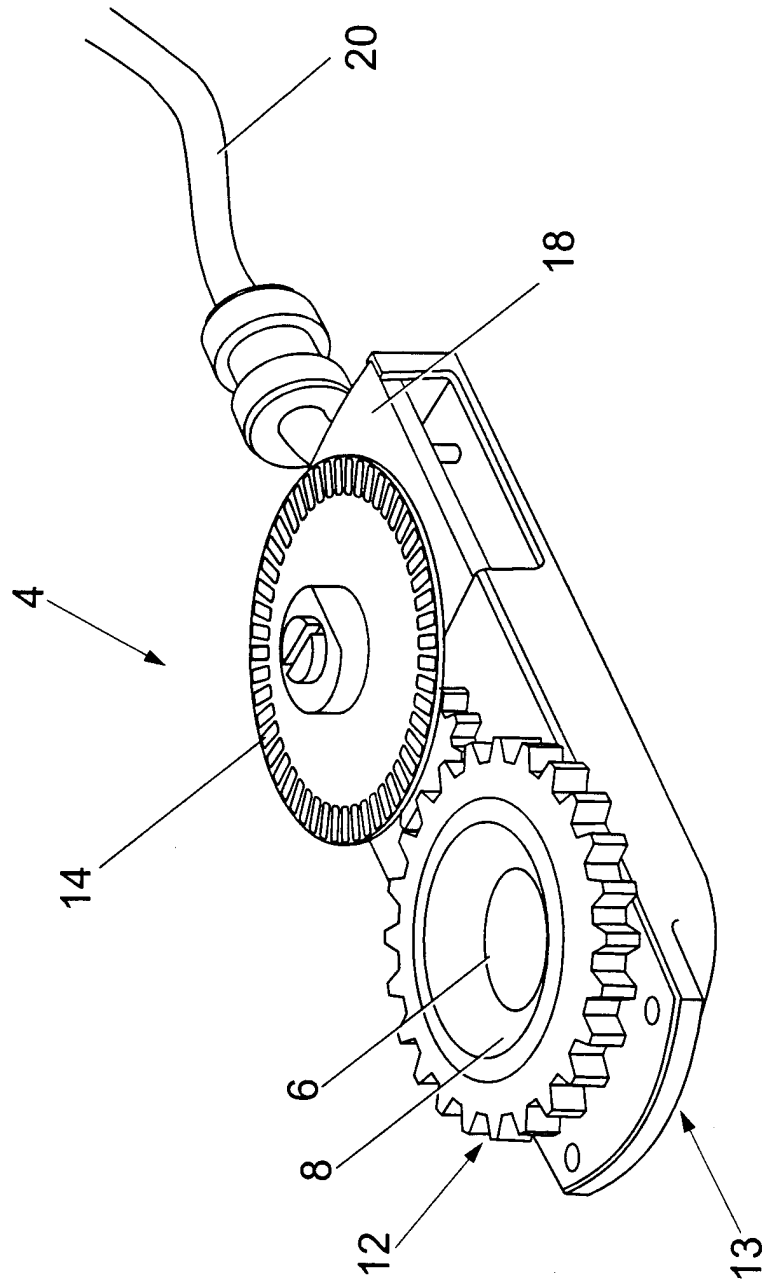

Fig. 4

4 / 9

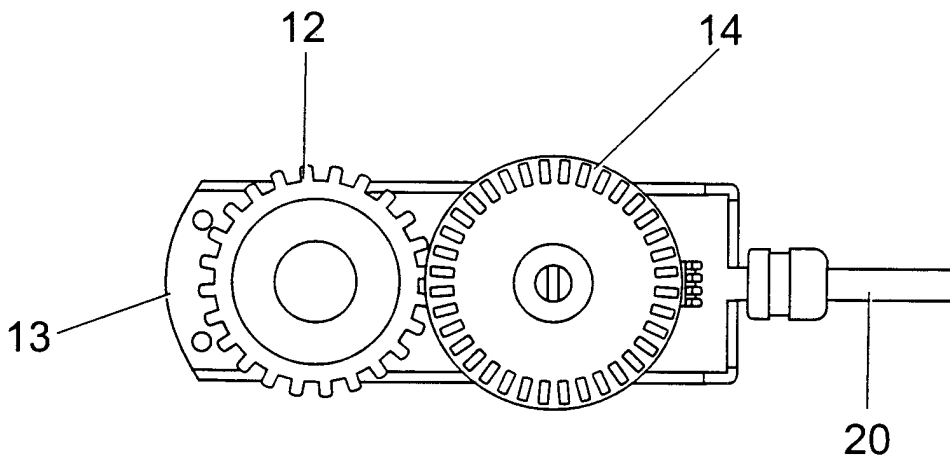

Fig. 5a

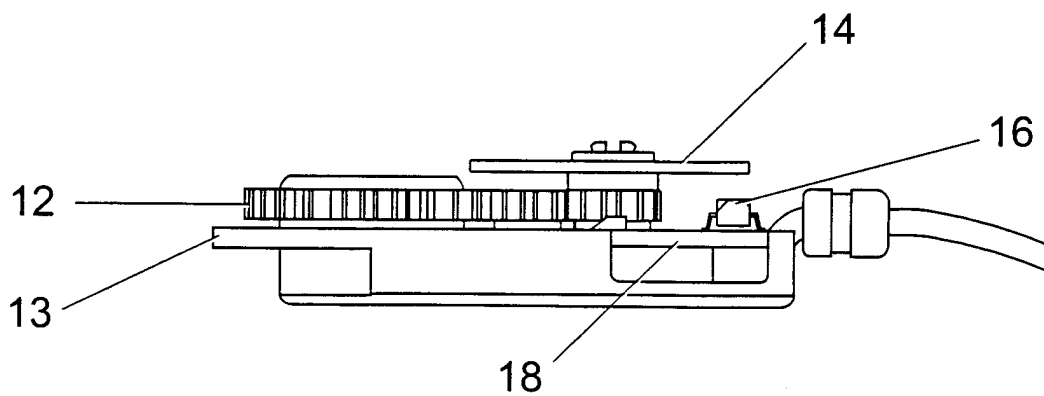

Fig. 5b

5 / 9

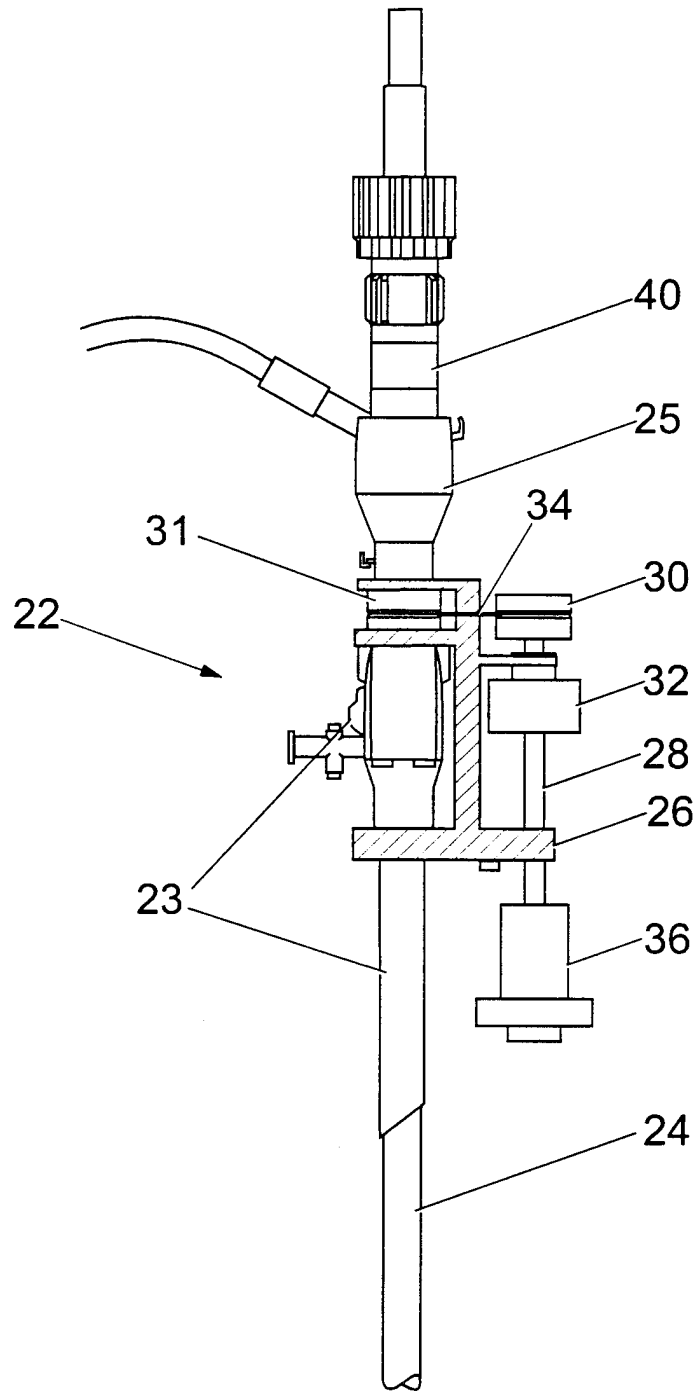

Fig. 6

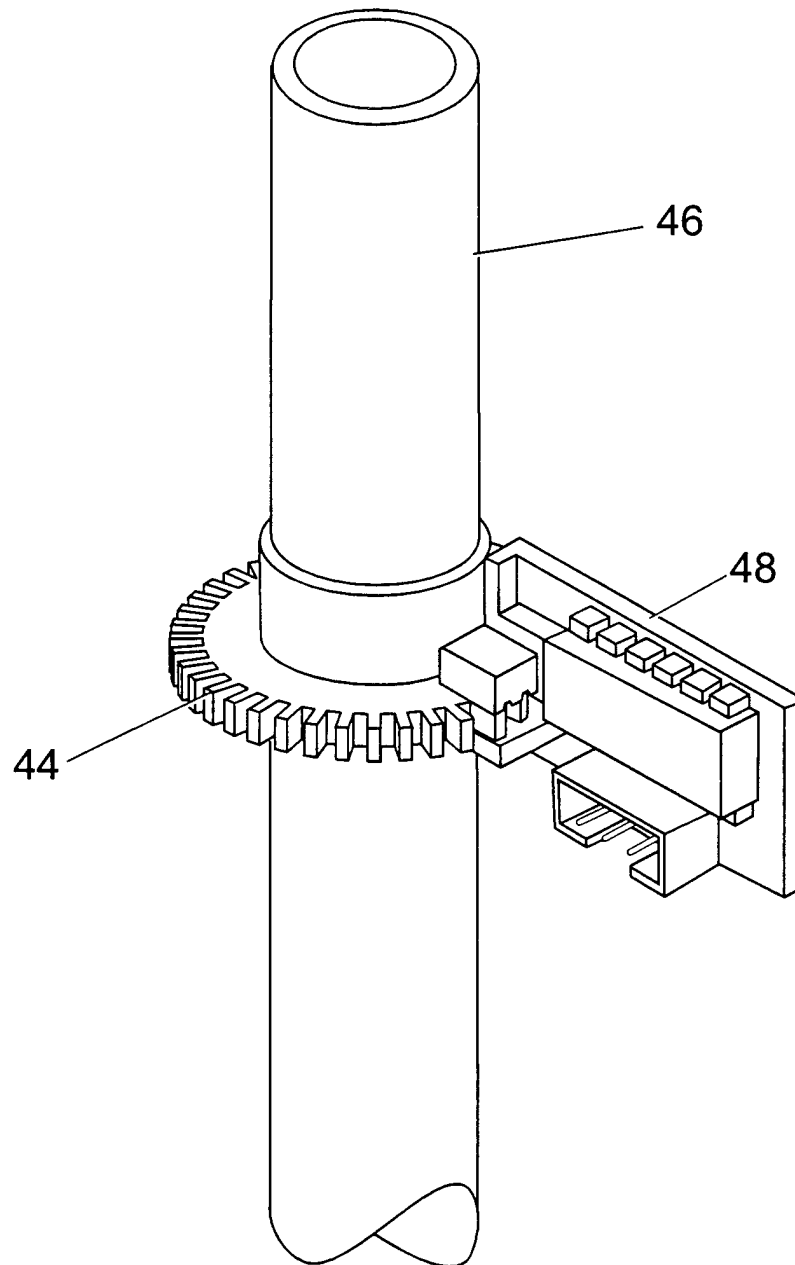

Fig.7

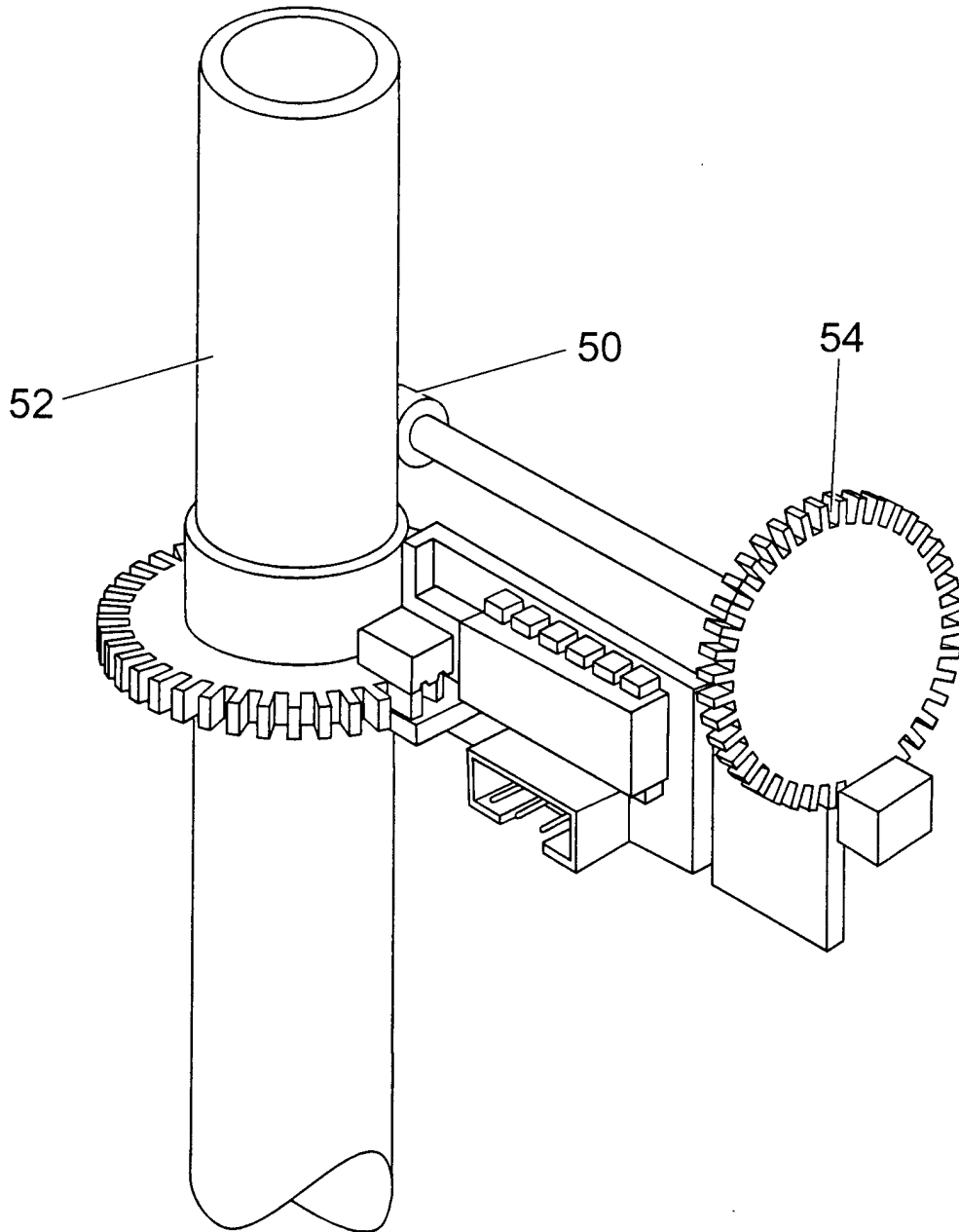

Fig.8

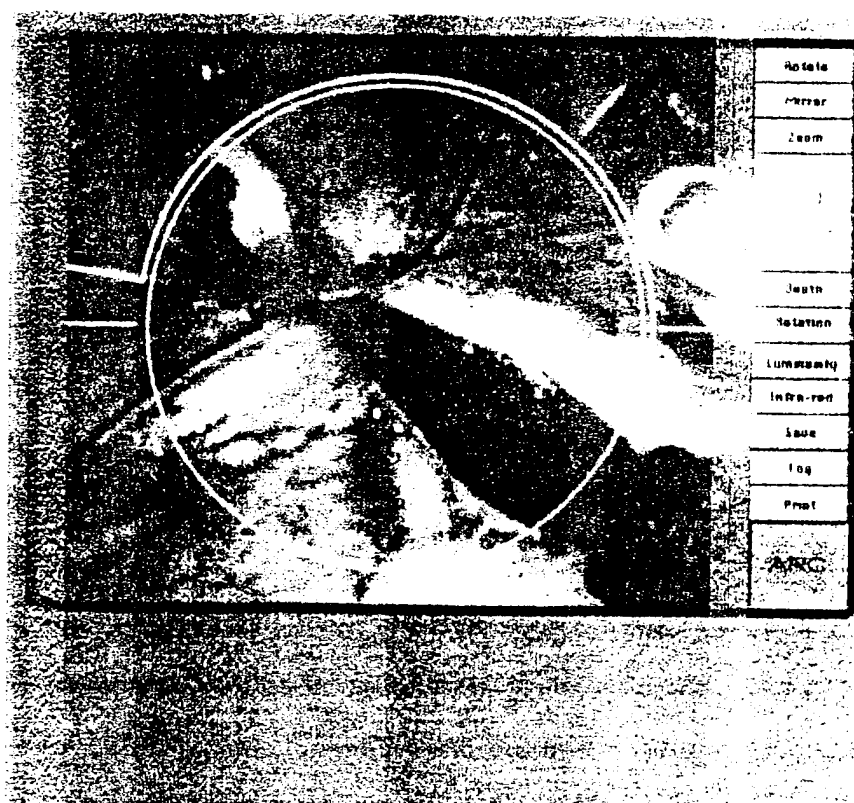

Fig.9

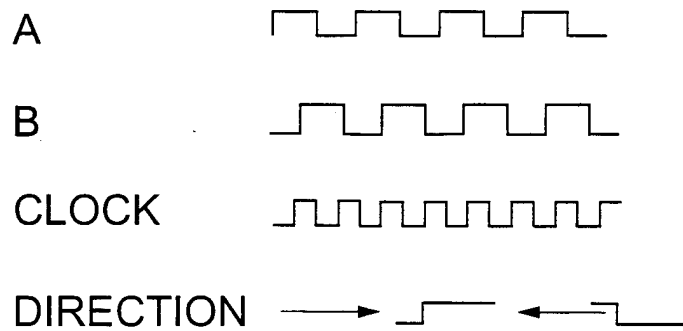
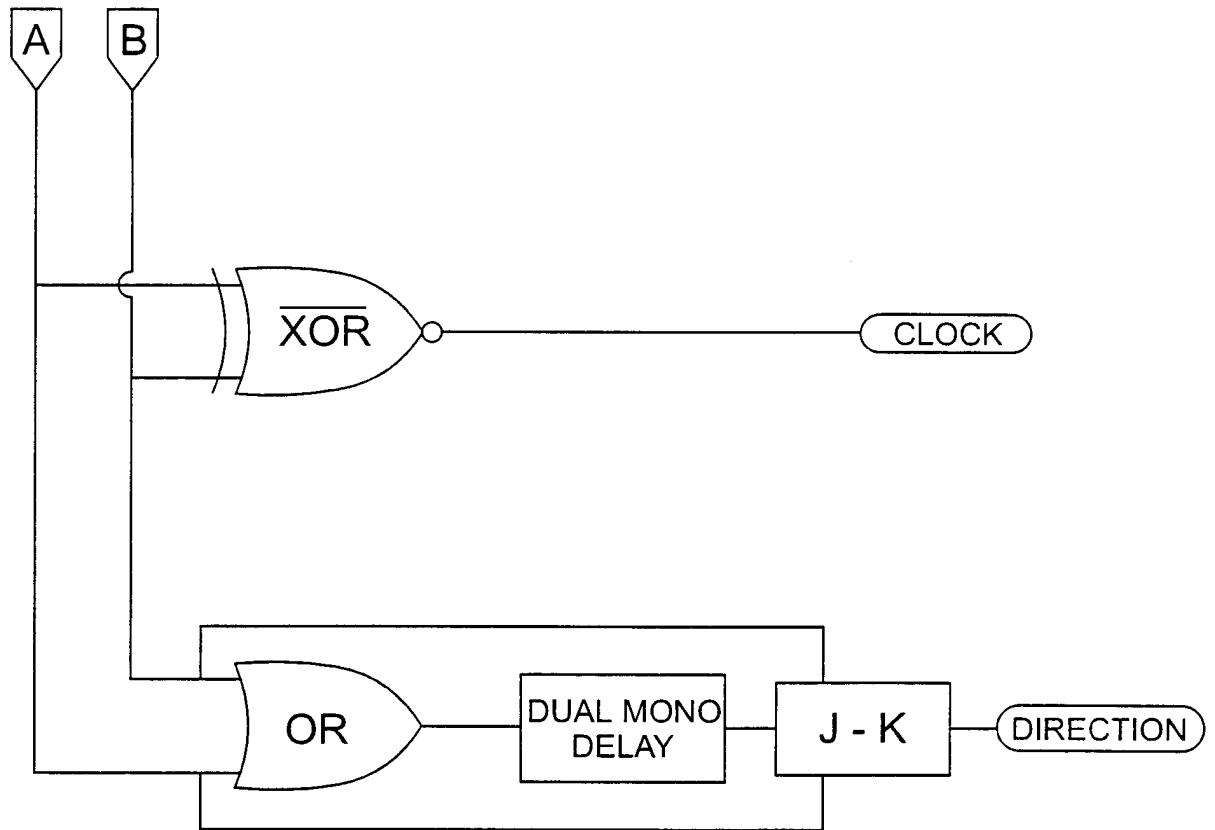

Fig. 10

专利名称(译)	手术照相机设备和方法		
公开(公告)号	EP1207777A2	公开(公告)日	2002-05-29
申请号	EP2000956649	申请日	2000-08-10
[标]申请(专利权)人(译)	慕范围		
申请(专利权)人(译)	G. SCOPE LIMITED		
当前申请(专利权)人(译)	G. SCOPE LIMITED		
[标]发明人	GALLAGHER ANTHONY GERALD NEIL WILLIAM JOHN		
发明人	GALLAGHER, ANTHONY GERALD NEIL, WILLIAM, JOHN		
IPC分类号	A61B1/313 A61B17/00		
CPC分类号	A61B1/00147 A61B1/313 A61B17/00234		
优先权	1999018703 1999-08-10 GB		
外部链接	Espacenet		

摘要(译)

本发明描述了一种适于接收可在患者体内使用的手术相机的装置，该装置具有检测相机相对于患者体内或周围的参考点的旋转和/或纵向运动的装置。参考点优选地是手术端口装置，并且该装置优选地适于与端口装置结合。通过检测和/或测量相机相对于参考点的任何旋转和/或纵向测量，外科医生可以在参考参考点的过程中了解相机的期望或不期望的移动。这些信息在腹腔镜或内窥镜手术中特别有用。