

(19)



(11)

EP 2 961 334 B1

(12)

EUROPEAN PATENT SPECIFICATION

(45) Date of publication and mention of the grant of the patent:
06.06.2018 Bulletin 2018/23

(51) Int Cl.:
A61B 17/128 (2006.01) A61B 17/29 (2006.01)
A61B 17/00 (2006.01)

(21) Application number: **14757805.8**

(86) International application number:
PCT/US2014/015807

(22) Date of filing: **11.02.2014**

(87) International publication number:
WO 2014/133751 (04.09.2014 Gazette 2014/36)

(54) **SYSTEMS FOR MAGNETICALLY SUSPENDING TISSUE STRUCTURES**

SYSTEME ZUM MAGNETISCHEN AUFHÄNGEN VON GEWEBESTRUKTUREN

SYSTÈMES POUR SUSPENDRE MAGNÉTIQUEMENT DES STRUCTURES TISSULAIRES

(84) Designated Contracting States:
AL AT BE BG CH CY CZ DE DK EE ES FI FR GB GR HR HU IE IS IT LI LT LU LV MC MK MT NL NO PL PT RO RS SE SI SK SM TR

- **ROHANINEJAD, Morteza**
Saratoga, CA 95070 (US)
- **ROHANINEJAD, Mohammadreza**
San Jose, CA 95124 (US)

(30) Priority: **27.02.2013 US 201361770159 P**
18.09.2013 US 201314030581

(74) Representative: **Boult Wade Tennant**
Verulam Gardens
70 Gray's Inn Road
London WC1X 8BT (GB)

(43) Date of publication of application:
06.01.2016 Bulletin 2016/01

(73) Proprietor: **Rohaninejad, Mohammadreza**
San Jose, CA 95124 (US)

(56) References cited:
WO-A1-2010/041714 WO-A1-2010/121282
US-A1- 2002 107 533 US-A1- 2007 004 958
US-A1- 2007 004 958 US-A1- 2007 135 678
US-A1- 2007 156 028 US-A1- 2007 161 855
US-A1- 2009 192 344 US-A1- 2010 204 727
US-A1- 2010 204 727

- (72) Inventors:
- **MIRNAJAFI, Seyed, Ali**
Irvine, CA 92604 (US)
 - **ROHANINEJAD, Mostafa**
Saratoga, CA 95070 (US)

EP 2 961 334 B1

Note: Within nine months of the publication of the mention of the grant of the European patent in the European Patent Bulletin, any person may give notice to the European Patent Office of opposition to that patent, in accordance with the Implementing Regulations. Notice of opposition shall not be deemed to have been filed until the opposition fee has been paid. (Art. 99(1) European Patent Convention).

Description**BACKGROUND OF THE INVENTION**1. Field of the Invention.

[0001] The present invention relates generally to medical devices. More particularly, the present invention relates to systems for magnetically suspending tissue structures during minimally invasive surgical procedures.

[0002] A number of surgical procedures which previously required open surgery are now performed by laparoscopy and other minimally invasive procedures. In laparoscopic procedures, a camera and a number of tools are introduced into a body cavity through ports or other passages formed through the patient's skin. In many procedures, the abdomen is insufflated and several ports are placed through the patient's abdominal wall. The camera is introduced through one of the ports, and the remaining ports are used for introducing tools needed to manipulate internal tissue structures and to remove, oblate, cauterize, cut, or otherwise modify these tissue structures.

[0003] One limitation of such laparoscopic and other minimally invasive procedures is the limited number of ports available at any one time to accommodate the tools required to perform the procedures. In order to reduce the number of needed ports, it has been proposed to use external magnets to suspend and position organs. The magnets could thus perform the role of a tissue grasper without the need to utilize one of the available access ports. For example, a magnetic element may be introduced into the body cavity through a port or otherwise. The magnetic element will be coupled to a target organ and an external magnet used to attract and position the magnetic element in order to in turn position the organ as needed for the procedure. Several specific systems for magnetically suspending organs and tissue structures are described in the references identified below in the Description of the Background Art.

[0004] Although quite promising, such magnetic tissue suspending systems have typically been cumbersome to deploy, difficult to reposition during a procedure, and difficult to release and remove after the procedure is over. It is an object of the present invention to overcome at least some of these deficiencies.

2. Description of the Background Art.

[0005] U.S. Patent Publ. Nos. 2010/0204727; 2009/0043246; 2012/0088965; and 2012/0238796 and PCT Publication WO2009/019288 describe magnetic tissue suspension systems useful in laparoscopic procedures. U.S.

[0006] Patent No. 7,169,104 describes a magnetic tissue suspension system useful in endoscopic procedures. U.S. Patent No. 7,766,810; U.S. Patent Publ. 2008/0171907; and WO2008/089049 describe systems

for filling an organ with a magnetic material and thereafter magnetically manipulating the organ. US2007/0135678A1 describes a magnetic suspension system using an electromagnet as a magnetic element. US2002/0107533A1 describes a surgical clamp system having detachable clamps connected to a shaft through a threaded connection.

SUMMARY OF THE INVENTION

[0007] The present invention provides improved systems for magnetically suspending and manipulating tissue structures during laparoscopy and other minimally invasive surgical procedures.

[0008] According to the present invention there is provided a tissue suspension system having the features of claim 1 and preferred embodiments are disclosed in the dependent claims. The systems provide a simplified and efficient protocol for introducing a tissue grasper attached to a magnetic element into a body cavity through a laparoscopic port or other tissue passage. The tissue grasper, magnetic element, and an adjustable tether connecting them together, are introduced simultaneously through the laparoscopic port or other tissue passage using a single shaft. After releasing the magnetic element from the shaft, the shaft is used to position the tissue grasper adjacent to the target tissue structure. The tissue grasper is then opened, placed over the tissue structure, and closed to firmly grasp the tissue structure. The tissue grasper is then released from the single shaft and the shaft removed from the body cavity. A conventional or other laparoscopic grasper is then introduced into the body cavity to grasp the magnetic element and position the magnetic element adjacent to an external magnet which attracts the magnetic element and allows positioning the element by moving the external magnet over the patient's skin. The laparoscopic grasper can also be used to tighten or cinch the tether by pulling on the tether which locks in place after appropriate tensioning.

[0009] A particular object of the present invention is to provide variable control of the magnetic field which is created between the magnetic coupling element within the body cavity and the external suspension magnet present over the patient's skin. While the use of fixed magnets and/or magnetic materials which are not themselves magnets comes within the scope of the present invention, at least one of the magnetic coupling element and the external suspension magnet is configured to provide an adjustable magnetic field. The most common magnets having adjustable field strength are electromagnets, which typically comprise a wound helical coil of wire, usually having an iron core. When current flows through the helical coil, the iron core acts as a magnet, where the strength and polarity of the magnetic field created are adjustable by changing the magnitude of and/or the direction of current flow through the wire. A variety of conventional circuits are available for coupling to an electromagnet to provide a variable, adjustable magnetic field.

[0010] While at least one of the magnetic coupling element and the external suspension magnet will have an adjustable magnetic field, the other magnetic element may be a permanent magnet or a temporary magnet. Permanent magnets are those which retain a generally fixed level of magnetism over time and which are typically made of permanently magnetizable materials, such as neodymium-iron-boron alloys, samarium-cobalt alloys, alnico alloys, as well as ceramic and ferrite materials. Temporary magnets are typically made from iron and other ferrite materials.

[0011] While using an electromagnet or other magnet having an adjustable field as the external suspension magnet will be most common, it will also be possible to use an electromagnet or other adjustable field magnet as the magnetic coupling element within the body cavity. In some cases, it will be desirable to form both the external suspension magnet and the magnetic coupling element as electromagnets or other adjustable field strength magnets. It will be appreciated that by having both the external suspension magnet and the internal magnetic coupling element be capable of providing an adjustable magnetic field, the magnetic traction between these magnetic elements can be adjustable over a wide range of field strengths. The ability to adjust the field strength is desirable for many reasons. For example, the strength may be adjusted when it is desirable to move the external suspension magnet over the patient's body surface in order to pull or drag the internally located magnetic coupling element. It will also be desirable to be able to adjust the magnetic field strength at different portions of the surgical procedure. A strong magnetic field may be necessary at times that significant tension is being placed on the tether. At other times, however, it may be desirable to reduce the magnetic strength between the magnetic coupling element and the external suspension magnet, for example in order to lessen the compressive force being applied to the tissue in order to reduce the inhibition of blood circulation over extended time periods. The electromagnet will usually include a controller unit, and the controller unit will usually be adjustable or programmable for one or more purposes. For example, software may be provided to determine or calculate the optimal magnetic force to accommodate an abdominal thickness, tool size, supporting force, or the like, and to calculate the desired holding force and the electrical power needed to generate the desired force.

[0012] The tissue suspension system comprises a grasper placement tool having a shaft, a tissue grasper, a magnetic coupling element, and a tether securing the magnetic coupling element to the tissue grasper. The tissue grasper is detachably secured to a distal end of the shaft, allowing the tissue grasper to be released once it has been secured to a target tissue structure. Such a release mechanism eliminates the need to provide a separate tool to remove and place the tissue grasper as required by several of the proposed system.

[0013] In a preferred aspect, the grasper placement

tool has a rigid narrow shaft configured for laparoscopic introduction into a patient's insufflated abdomen. Typically, the shaft will have a diameter intended for insertion through a conventional laparoscopic port, e.g. having a diameter of 5 mm, 10 mm, or 12 mm. The tissue grasper may be secured to the shaft of the grasper placement tool by any suitable mechanical attachment mechanism, typically being a bayonet attachment which can be released via a mechanism located at a proximal end of the shaft. The tissue grasper includes a pair of clamping jaws which can be typically opened and closed from the proximal end of the shaft. The tissue grasper is specifically configured to be closed over the tissue structure while the tissue grasper remains attached to the shaft. The tissue grasper is further configured to remain closed over the tissue even after being detached from the shaft.

[0014] In specific embodiments of the present invention, the jaws of the tissue grasper will be attached to a rod which can be moved in order to open and close the jaws. Typically, the tissue grasper placement tool includes a driver which engages the rod of the tissue grasper allowing the rod to be reciprocated in order to open and close the jaws while the tissue grasper remains on the shaft.

[0015] In further specific embodiments, the magnetic coupling element will be configured so that it can be carried by the jaws when the grasper placement tool is being introduced into the body cavity. In such a configuration, the magnetic element, the tissue grasper, and the shaft of the tissue grasper placement tool will preferably be coaxially aligned in order to minimize the profile and allow the assembly to be introduced through a laparoscopic or other port simultaneously in a single motion. That is, the tissue grasper will have an axis which is aligned with an axis of the shaft and usually with an axis of the magnetic element. This allows the shaft, tissue grasper, and magnetic element to be inserted together in tandem through the laparoscopic port or other access passage.

[0016] The length of tether between the tissue grasper and the magnetic element is preferably adjustable. For example, the tether may be configured to be pulled through the magnetic coupling element and to be selectively locked once a proper tension on the tissue structure has been achieved. A variety of suitable locking mechanisms may be provided on the magnetic element, including mechanically actuable locking mechanisms and magnetically actuable locking mechanisms. In some embodiments, as a safety measure, the locking mechanism can be configured to allow the tether to slip when excessive tension is applied.

[0017] The assembly of the tissue grasper placement tool, magnetic element, and tether, as just described, is combined in a system that further includes the external magnet and optionally a frame, arm or other support structure for holding the external magnet in place during a procedure. Such support structures will typically be configured to be secured to a table and they may optionally include a shape lock mechanism for facilitating re-

positioning.

[0018] There is also described an exemplary method for supporting an internal tissue structure using an external magnet. A shaft is introduced through a percutaneous passage, such as a laparoscopic port, into a body cavity of a patient, such as an insufflated abdomen. A distal end of the shaft carries a tissue grasper and a magnetic coupling element. The tissue grasper is secured to the magnetic coupling element by a tether. The magnetic coupling element is released from the shaft within the cavity while maintaining connected to the grasper by the tether. The tissue grasper is then secured over the tissue structure while the grasper remains on the shaft. Usually, a driver or other mechanism in the shaft is used to lock the grasper in the required gripped position. The tissue grasper is then released from the shaft after having been secured over the tissue structure. The external magnet is then positioned over the patient's skin to attract and hold the magnetic coupling element in place. The tether is then cinched to position the tissue structure as desired.

[0019] The shaft, tissue grasper, and magnetic coupling element are usually aligned in tandem as they are introduced through the percutaneous passage. Such an aligned configuration simplifies the introduction of these three system components, significantly reducing the complexity of the procedure. Typically, the magnetic coupling element is carried by the tissue grasper while being introduced through the port or other tissue passage, and the magnetic coupling element can be released by simply opening the tissue grasper.

[0020] The tissue grasper comprises opposed jaws, and securing the tissue grasper over the tissue comprises closing the jaws over the tissue where the jaws remain closed after the tissue grasper has been released from the shaft. In specific procedures, closing the jaws over the tissue structure comprises actuating a driver in the shaft to cause the jaws to close where the jaws remain closed after such actuation stops.

[0021] Releasing the tissue grasper from the shaft typically comprises actuating a coupling mechanism, such as a bayonet connector, on the shaft, to release the tissue grasper. The exemplary methods may further comprise positioning the external magnet using a supporting structure, such as support arm attached to the patient bed or operating table. Cinching the tether may comprise grasping the tether and pulling the tether through a lock on at least one of the magnetic coupling element in the tissue grasper. The exemplary methods may further comprise releasing the tissue grasper from the tissue structure after the procedure has been completed.

BRIEF DESCRIPTION OF THE DRAWINGS

[0022] The features of the invention are set forth with particularity in the appended claims. A better understanding of the features and advantages of the present invention will be obtained by reference to the following detailed description that sets forth illustrative embodiments, in

which the principles of the invention are utilized, and the accompanying drawings of which:

FIG. 1 illustrates the grasper placement tool connected to a tissue grasper and a magnetic element. FIGS. 2A and 2B are detailed end views of the grasper placement tool of FIG. 1 shown with the tissue grasper holding the magnetic element (FIG. 2A) and with the tissue grasper open (FIG. 2B).

FIG. 3 is a cross-sectional view of the grasper placement tool of FIG. 1 shown without the tissue grasper. FIG. 4A is a detailed, end view of the grasper placement tool shown with a bayonet connector holding the tissue grasper in place.

FIG. 4B is a detailed, end view of the grasper placement tool shown with the jaws of the tissue grasper open.

FIG. 4C is a detailed, end view of the grasper placement tool shown with the tissue grasper detached from the bayonet connector.

FIGS. 5A-5F illustrate a first tissue grasper.

FIGS. 5G-5I illustrate a second tissue grasper.

FIGS. 6A and 6B illustrate a third tissue grasper.

FIGS. 7A-7C illustrate a fourth tissue grasper.

FIGS. 8A and 8B illustrate a first exemplary magnetic element.

FIGS. 9A and 9B illustrate a second exemplary magnetic element.

FIGS. 10A and 10B illustrate a third exemplary magnetic element.

FIG. 10C illustrates an electromagnetic element which may be useful as the magnetic element.

FIGS. 11A-11I illustrate the grasper placement tool used for positioning a tissue grasper and magnetically suspending it in accordance with a described exemplary method.

FIGS. 12A and 12B illustrate an exemplary external magnet.

FIGS. 13A and 13B illustrate the external magnet being supported by a shape-lock arm.

Figs. 14A-14D illustrate a fifth tissue grasper.

Figs. 15A-15D illustrate a sixth tissue grasper.

Figs. 16A-16C illustrate a seventh tissue grasper.

DETAILED DESCRIPTION

[0023] Referring to FIG. 1, a tissue grasper placement tool 10 includes a shaft 12 which carries a tissue grasper 14 at its distal end. A magnetic element 16 is secured to the tissue grasper 14 by a tether 18. A handle 20 at the proximal end of shaft 12 includes a trigger 22 which is used for opening and closing the opposed jaws 34 and 36 and also for detaching the tissue grasper 14 from the shaft 12, as will be described in more detail below. A detachment sleeve 23 on shaft 12 is also provided to detach the tissue grasper 14, and a rotatable knob 24 is provided at the proximal end of a driver 28 (FIGS. 2A, 2B and 3) and is used to lock the opposed jaws 34 and

36 of the tissue grasper 14 in place in any desired position, as will also be described in more detail below.

[0024] Referring now to FIGS. 2A and 2B, the tissue grasper 14 will preferably hold the magnetic element 16 between the opposed jaws 34 and 36, as shown in FIG. 2A, while the tool end is being introduced into a target body cavity through a laparoscopic port or other tissue passage. Once in place, the jaws 34 and 36 may be opened, as shown in FIG. 2B, to release the magnetic element 16. In the open configuration of FIG. 2B, the jaws 34 and 36 of tissue grasper 14 will also be in position to engage and be tightened over a target tissue structure, as will be described in more detail below.

[0025] Referring now to FIG. 3, a bayonet connector 26 is used for detachably securing the tissue grasper 14 in the position shown in FIG. 1. The bayonet connector may be of generally conventional construction, including one or a pair of detents 27 which are received in opposed apertures 32 (FIG. 4A) in a shank region of the tissue grasper 14. The shaft 12 is axially split into a pair of opposed prongs 30 which may be squeezed together in order to release the detent pins 27 when it is desired to detach the tissue grasper 14 from the shaft. The grasper release mechanism 23 allows the user to close the prongs and the trigger 22 can be used to advance the driver 28 to push the grasper off of the bayonet connector. As shown in FIG. 3, the trigger 22 may be pulled (as shown in broken line) to advance a distal end 40 of the driver 28 (as also shown in broken line).

[0026] Referring now to FIG. 4B, the rotatable knob 24 may be used to rotate driver 28 (as shown by an arrow) in order to lock the opposed jaws 34 and 36, as will be described in greater detail below.

[0027] FIG. 4C illustrates the tissue grasper 14 after the jaws have been closed and the grasper released from the bayonet connector 26.

[0028] Referring now to FIGS. 5A-5F, a first tissue grasper 114 will be described. The tissue grasper 114 comprises an upper jaw 134 pivotally attached to a lower jaw 136 and having a shank region 152 at a proximal end thereof. Although not illustrated in FIGS. 5A-5F, the bayonet connector 26 of the shaft 30 of the grasper placement tool 10 will be received within the open end of the shank and will engage apertures (as described previously for detachably securing the tissue grasper 114). The distal end 40 of the driver 28 will be configured to engage a proximal end (to the right in FIG. 5A) of a piston 150 with a threaded proximal end 154. The threaded end 154 is rotatably attached to a follower 151 secured to a link 156. In this way, the driver 28 can be used to rotate the piston between a locked configuration, as shown in FIG. 5A, where the threads on the piston engage mating threads on an inner surface of the shank 152, and an unlocked configuration as shown in FIG. 5C, where the piston has been rotated 180 degrees so that the threads no longer engage each other. In the unlocked configuration of FIGS. 5C and 5D, the driver 28 may be used to advance the piston distally to close the upper jaw 134.

The piston 150 may then be rotated back to the position of FIG. 5A and FIG. 5B in order to lock the jaw closed if desired. Otherwise, a spring 160 may be configured to self-open the jaws when the piston is free to translate and no force is applied to piston by the driver 28. A portion 162 of the shank 152 is pivotally attached so that the portion may be opened to disengage the piston whenever desired, allowing the jaws to open.

[0029] In variations of the grasper 114 of Figs. 5A-5F, the shank 152 may be replaced by a cylinder with a full internal thread. The follower 151 and the threaded end 154 of the piston 150 remain rotatably coupled, and a hex or other driver can be temporarily engaged with the shank 152 and piston 150 to rotate the threaded end 154 to translate the piston distally and proximally within the shank to open and close the jaws 134 and 136. When the piston 150 is fully distally advanced against the follower, the jaws will remain locked until the driver is re-engaged to drive the piston 150 proximally to release the jaws.

[0030] Referring now to FIGS. 5G-5I, a second tissue grasper 164 will be described. The tissue grasper 164 comprises an upper jaw 166 pivotally attached to a lower jaw 168 and having a shank region 170 at a proximal end thereof. The shank region 170 is detachably received in an open end of the shaft 12 of the previously illustrated tissue grasper placement tool 10. A distal end 172 of a hex driver shaft 174 is configured to pass through a complementary hexagonal axial passage through a threaded piston 176 having a protruding distal end 178. A follower 180 is pivotally attached to one end of a link 182 which is pivotally attached at its other end to the upper jaw 166. In this way, the hex driver 174 can be passed through the passage in the threaded piston 176 to engage a proximal end of the follower to close the upper jaw 166 as shown in Fig. 5H. Once the jaws have been closed over a target tissue T, the hex driver 174 can be rotated to drive the threaded piston 176 forward to lock the jaws over the tissue. As with earlier designs, a spring 184 is provided to hold the jaws 166 and 168 open, as shown in Fig. 5G, when the follower 180 is proximally retracted. When it is desired to release the jaws, the hex driver 174 and shaft 12 may be re-engaged with the shank 170 and the hex driver used to rotate the threaded piston 176 to release the force against the follower 174, allowing the spring 184 to open the jaws.

[0031] Referring now to FIGS. 6A and 6B, an alternative tissue grasper 214 is illustrated. A piston 350 is attached through a link 356, and the opening/closing mechanism is similar to that described relative to FIGS. 5A-5F. The piston 350, however, is not rotatable and the only means for locking and unlocking the axial translation of the piston is a pivoting wall 362. Thus, the piston 350 is locked as shown in FIG. 6A and is unlocked as shown in FIG. 6B.

[0032] A fourth alternatively designed tissue grasper 314 is illustrated in FIGS. 7A-7C. Piston 350 is free to axially translate in either a proximal or distal direction

within shank 352. The upper jaw 334 is locked relative to the lower jaw 336 by a curved ratchet strip 370 which can be opened as shown in FIG. 7B or closed as shown in FIG. 7C in order to permit or prevent opening and closing of the jaws.

[0033] Referring now to FIGS. 8A and 8B, a first exemplary magnetic coupling element 416 is illustrated. The tether 18 passes at a 90 degree angle from one corner of the magnetic element to an opposed corner. A magnetic shuttle 450 can be moved from an open configuration, as shown in FIG. 8A, where the tether 18 is free to move through the magnetic element 416 to a closed configuration, as shown in FIG. 8B, where the tether 18 is locked relative to the magnetic element. The magnetic shuttle 450 may be actuated, for example, when the magnetic element 416 is being held by the external magnet which will draw the magnetic shuttle 450 into the locked configuration as shown in FIG. 8B. This configuration is particularly convenient since no separate action is needed to lock and unlock the tether. By properly orienting surface features 452, the tether 18 may be drawn in a cinching or tightening direction even when the shuttle is closed, but prevented from moving in the opposite direction since the features 452 will cut or bite into the tether if it moves in the opposite direction.

[0034] Referring now to FIGS. 9A and 9B, an alternative magnetic element 516 is illustrated where tether 18 passes through an open passage 550. Once the tether is sufficiently tight, a locking element 560 can be moved against the body of the magnetic element 516, shown in FIG. 9B in order to prevent the tether 18 from being pulled out of the passage 550. The locking element 560 can be a conventional spring lock with a button 562 available to release the lock.

[0035] Referring now to FIGS. 10A and 10B, a third alternative magnetic element 616 is illustrated. The tether has a ratcheted section 618 which travels past a pivoted element 620. The pivotable element 620 carries a tooth 622 which engages the ratchets 618 to prevent the tether from being drawn out of the magnetic element. The tether, however, may be tightened as the ratchet will travel over the tooth 622 in that direction only. A torsion or other spring element (not illustrated) is usually provided to urge the pivotable element 620 in a clockwise rotational direction against the ratcheted section 618 of the tether, as viewed in FIGS. 10A and 10B.

[0036] In all the designs described thus far, the magnetic element may comprise an electromagnet as illustrated in Fig. 10C. An electromagnetic element 700 may comprise a wire coil 702 wound over a core 704 mounted within a housing 706. Current is typically provided by an external power supply 708 connected to the electromagnetic element by a conductor cable 710 or in some cases by a radio frequency link. The power supply will include conventional circuitry to allow the magnetic field strength to be adjusted by the user, typically using a knob 712 or other convention manual controller connected to the power supply by a second cable 714. As described else-

where herein, the ability to adjust the magnetic field strength of both the external magnet and the internal magnetic element affords a great deal of flexibility to the user.

5 **[0037]** Referring now to FIGS. 11A-11I, an exemplary method for magnetically suspending a tissue structure in a body cavity will be described. The description will be made with respect to a tissue structure TS in an insufflated abdominal cavity A in a laparoscopic procedure, but the principles will apply to other endoscopic and minimally invasive procedures and other body cavities as well. For ease of illustration, the presence of laparoscopic ports has not been shown, and in fact the tools could be used without laparoscopic ports in some instances. Usually, however, the procedures would employ one or more conventional laparoscopic ports for providing tool access.

10 **[0038]** As shown in FIG. 11A, the grasper replacement tool 10 is introduced into the abdominal cavity A with the magnetic element 16 carried in the tissue grasper 14 which in turn is attached to the distal end of the shaft 12. By having these components axially aligned, the profile of the tool is minimized and the simultaneous introduction of all components is facilitated.

15 **[0039]** Once in the cavity, the jaws of the tissue grasper 14 (e.g. jaws 34 and 36 in FIG. 1) will be slightly opened to release the magnetic element 16, as shown in FIG. 11B. Any of the release mechanisms described above could be employed. The tissue grasper 14 is then moved to engage the tissue structure TS, and the jaws of the tissue grasper are tightened over the tissue structure, as shown in FIG. 11C, thus providing a firm grasp on the tissue structure.

20 **[0040]** The tissue grasper 14 is then detached from the shaft 12 of the grasper placement tool 10, as shown in FIG. 11D. Any of the detachment mechanisms described above could be utilized. The grasper placement tool 10 is no longer used in this procedure for suspending the tissue structure, but it could be used for removing the tissue grasper 14 by performing the steps that are now being described in an opposite order.

25 **[0041]** Referring now to FIG. 11E, a conventional laparoscopic grasper LG is next introduced into the abdominal cavity, optionally through the same port or tissue passage through which the grasper placement tool 10 has been passed. The jaws of the grasper LG are then used to grasp the magnetic coupling element 16, as shown in FIG. 11F. The magnetic coupling element 16 is next raised to the vicinity of an external magnet 80 which has been placed on the outer surface of the patient's abdominal wall AW, as shown in FIG. 11G. The strength of the magnetic field applied by the external magnet 80 may optionally be increased at this point in order to hold the coupling element 16 firmly as the tether 18 is cinched, as shown in FIG. 11H. The tether 18 may be cinched by using the jaws of grasper LG to grasp the free end of the tether and pull on said free end in order to tension the portion of tether 18 between the tissue

grasper 14 and magnetic element 16, as shown in FIG. 11H. Once the proper tension has been applied, as shown in FIG. 11I, the grasper LG can be released from the magnetic coupling element 16, and the physician is ready to continue with other portions of the procedure.

[0042] An exemplary external magnet 80 is illustrated in FIGS. 12A and 12B. The external magnet 80 preferably includes a side coupler 82 which permits attachment to a support arm, as described hereinafter. An electromagnet is formed by wrapping a solenoid or wire coil 84 over a magnetic core 86 in a conventional manner. Magnetic field controller 88 is provided and connected to an electrical cord 90 to provide power. Both a field strength adjustment knob 92 and a lock button 94 may be provided for unlocking the support frame 180. An unlock button 96 may be provided for releasing the magnetic element 16. Of particular use, the magnetic field strength may be adjusted using the knob 92 to an appropriate level to facilitate movement of the external magnet 80 over the patient's skin when it is desired to move the magnetic element 16 within the body cavity in order to manipulate the tissue structure TS. Circuits for smoothly adjusting the strength of an electromagnet from zero to maximum are well known in the art. See, for example, the circuit descriptions available at <http://homemadecircuitsandschematics.blogspot.com/>.

[0043] Usually, the external magnet 80 will be held in place using a support frame 180, as shown in FIGS. 13A and 13B. The support frame 180 may include a stand 182 which may be secured to the side of a bed or table T. An arm 184, such as a shape lock mechanism, may be attached to an electronic lock 186 at the top of the stand 182. The electronic lock may be in communication with the lock and unlock buttons 94 and 96 on the external magnet 80, allowing the user to lock and unlock the arm while still holding the magnet. In this way, the external magnet 80 may be manually positioned over the patient P, and after the desired position is reached, the external magnet may be locked in place until it is desired to further move the magnet and the coupled tissue structure.

[0044] Referring now to Figs 14A-14D, a fifth tissue grasper 200 will be described. The tissue grasper 200 comprises an upper jaw 202 to pivotally attach to a lower jaw 204 and having a shank region 206 at a proximal end thereof. A grasper placement tool assembly 208 comprises an inner tubular member 210, an outer tubular member 212, and a reciprocating pusher 214. A retaining ring 216 is carried near a distal end of the outer tubular member and is adapted to be pushed forwardly over ratcheting surfaces 218 on the top and bottom of the upper jaw 202 and lower jaw 204, respectively. As shown in Fig. 14A, the upper jaw 202 and lower jaw 204 are held open by a spring 222 disposed about pivot member 220. The shank 206 is held within the open end of the inner tubular member 210, and pusher 214 may be advanced in a distal direction to engage a follower 226 attached to a link 224 which is configured to close the upper jaw 202 over the lower jaw 204, as shown in Fig. 14B.

[0045] In order to hold the closed jaws together, the outer tubular member 212 may be advanced distally to push the retaining ring 216 over the ratcheting surfaces 218 of the upper and lower jaws, as shown in Fig. 14C.

The jaws will be closed and the ratcheting ring 216 advanced after the tissue grasper 200 has been secured onto a desired tissue target site. The grasper placement tool assembly 208 may then be withdrawn from the closed tissue grasper 200, as shown in Fig. 14D.

[0046] Referring now to Figs. 15A-15D, a sixth tissue grasper 230 will be described. The tissue grasper 230 includes an upper jaw 232 pivotally attached to a lower jaw 234 and having a shank region 236 at its proximal end. A grasper placement tool 238 comprises a tubular body having a reciprocating pusher 240 mounted therein. The shank region 236 of the tissue grasper 230 is detachably received in an open end of the tubular body of the grasper placement tool 238. The upper jaw 232 is attached to scissor arm 244 and the lower jaw 234 is attached to a scissor arm 242. The scissor arms are mounted in an opening 246 formed in a distal region of the shank and attached by a pivot pin 248. The scissor arms 242 and 244 are configured so that advancement of the pusher 240 can open the jaws as will be described below.

[0047] The upper jaw 232 and lower jaw 234 are normally held in their closed position, as shown in Figs. 15A and 15B, by a spring element (not shown). In order to open the jaws, the pusher 40 is advanced to spread the interior ends of the scissor arms 242 and 244, as shown in Fig. 15C. So long as the pusher arm remains advanced, the jaws will remain open, allowing them to be placed over a tissue structure by proper manipulation of the grasper placement tool 238. When the target tissue is properly between the jaws, the pusher element 240 may be proximally retracted, allowing the spring element to close the jaws onto the tissue. Various further locking elements may be provided, such as a retaining ring as described previously.

[0048] Referring now to Figs. 16A-16C, a seventh tissue grasper 250 will be described. The tissue grasper 250 comprises an upper jaw 252 pivotally attached to a lower jaw 254 and having a shank region 256 at a proximal end thereof. The shank region 256 is carried in the open end of a grasper placement tool 258 having a tubular body. The grasper placement tool further includes a rotatable shaft 260 which is mounted within the tubular body 262. The rotatable shaft 260 is coupled to a threaded shaft 264, and a threaded follower rides over the threaded shaft so that rotation of the threaded shaft translates the follower proximally and distally. In its distal-most configuration, the follower 266 causes an attached link 268 to close the upper jaw which is mounted on pivot pin 270. By rotating the rotatable shaft 260 in the opposite direction, the threaded shaft draws the follower 266 in a proximal direction in order to open the upper jaw 252, as best seen in Fig. 16A. One advantage of the rotation drive mechanism is that no springs are required and the jaws

252 and 254 will be held in place by the friction of the threaded shaft 264 and follower 266. Another advantage of the rotation mechanism is that rotatable shaft 260 can be linked and rotated by a servo motor (not illustrated) which makes this mechanism ideal for use in robotic surgery. This provides for a very tight grasp of tissue. The grasper placement tool 258 may be removed from the tissue grasper 250 after the jaws have been closed over tissue, as shown in Fig. 16C. The jaws may then be removed by recoupling the grasper placement tool 258 in order to rotate the rotatable shaft 260 in the opposite direction in order to open the jaws and release them from the tissue.

[0049] While preferred embodiments of the present invention have been shown and described herein, it will be obvious to those skilled in the art that such embodiments are provided by way of example only. Numerous variations, changes, and substitutions will occur to those skilled in the art without departing from the invention. It should be understood that various alternatives to the embodiments of the invention described herein may be employed in practicing the invention. It is intended that the following claims define the scope of the invention.

Claims

1. A tissue suspension system comprising:

a grasper placement tool (10) having a shaft (12) with a distal end;

a tissue grasper (114) detachably secured to the distal end of the shaft (12), wherein the tissue grasper (114) includes a pair of pivotally attached clamping jaws (134, 136), a piston (150) and a link (156) which drivably connects the piston (150) to the jaws (134, 136), wherein the piston (150) is configured to open and close the jaws (134, 136) via the link (156) so that the tissue grasper (114) can be closed over tissue and remain closed over tissue after being detached from the grasper placement tool (10), wherein the piston (150) comprises external threads which selectively engage internal threads on an internal surface of a shank portion (152) of the tissue grasper (114), and wherein a shank portion (162) is pivotally attached and is configured to be opened and closed to disengage and engage the external and internal threads ;

a magnetic coupling element (16);

a tether (18) securing the magnetic coupling element (16) to the tissue grasper (114); and
an external suspension magnet (80), wherein at least one of the magnetic coupling element (16) and the external suspension magnet (80) is configured to provide an adjustable magnetic field.

2. A system as claimed in claim 1, wherein the magnetic

coupling element (16) comprises a permanent magnet.

3. A system as claimed in any one of claims 1 to 2, wherein the external suspension magnet (80) comprises a permanent magnet.

4. A system as claimed in any one of the preceding claims, wherein the grasper placement tool (10) comprises a rigid narrow shaft (12) configured for laparoscopic introduction to a patient's abdomen.

5. A system as claimed in claim 4, wherein the tissue grasper (114) is secured to the shaft (12) by a bayonet attachment (26) which can be released from a proximal end of the shaft (12).

6. A system as claimed in claim 1, wherein the tissue grasper placement tool (10) includes a driver (28) which engages and rotates the piston (150) to open and close the jaws (134, 136).

7. A system as claimed in claim 1, wherein the magnetic coupling element (16) is configured to be carried by the jaws (134, 136) when closed and to be released by opening the jaws (134, 136) while the tissue grasper (114) remains attached to the distal end of the shaft (12).

8. A system as claimed in one of the preceding claims, wherein the tissue grasper (114) has an axis which is aligned with an axis of the shaft (12) so that the tissue grasper (114) and the shaft (12) may be inserted together in tandem through a laparoscopic access passage.

9. A system as claimed in claim 8, wherein the magnetic coupling element (16) has an axis which is aligned with the axes of the shaft (12) and of the tissue grasper (114) so that the magnetic coupling element (16), the tissue grasper (114), and the shaft (12) may be inserted together in tandem through the laparoscopic access passage.

10. A system as claimed in one of the preceding claims wherein the length of the tether (18) between the tissue grasper (114) and the magnetic coupling element (16) is adjustable, and wherein the tether (18) is configured to be pulled through the magnetic coupling element (16) and selectively locked with a locking mechanism on the magnetic coupling element (16).

11. A system as claimed in claim 10, wherein the locking mechanism is mechanically or magnetically actuable.

12. A system as claimed in claim 11, wherein locking

mechanism allows the tether (18) to slip if excess tension is applied.

13. A system as claimed in one of the preceding claims, wherein the external suspension magnet (80) includes a coupler for removable attachment to a support arm (184).
14. A system as claimed in claim 13, further comprising a support arm (184) adapted to be secured to a table (T).
15. A system as claimed in claim 14, wherein the support arm (184) comprises a shape lock mechanism.

Patentansprüche

1. Gewebe-Haltesystem, umfassend:

ein Greifer-Platzierungswerkzeug (10) mit einem Schaft (12) mit einem distalen Ende;
 einen Gewebegreifer (114), welcher lösbar an dem distalen Ende des Schafts (12) gesichert ist, wobei der Gewebegreifer (114) ein Paar von schwenkbar angebrachten Klemmklaue (134, 136), einen Kolben (150) und ein Verbindungselement (156) umfasst, welches den Kolben (150) mit den Klauen (134, 136) antreibbar verbindet, wobei der Kolben (150) dazu eingerichtet ist, die Klauen (134, 136) mittels des Verbindungselements (156) zu öffnen und zu schließen, so dass der Gewebegreifer (114) über einem Gewebe geschlossen werden kann und über dem Gewebe geschlossen bleibt, nachdem er von dem Greifer-Platzierungswerkzeug (10) gelöst worden ist, wobei der Kolben (150) Außengewinde umfasst, welche selektiv mit Innengewinden an einer Innenfläche eines Schenkelabschnitts (152) des Gewebegreifers (114) eingreifen, und wobei ein Schenkelabschnitt (162) schwenkbar angebracht ist und dazu eingerichtet ist, geöffnet und geschlossen zu werden, um die Außen- und Innengewinde aus einem Eingriff heraus und in einen Eingriff hinein zu bringen;
 ein magnetisches Kopplungselement (16);
 einen Strick (18), welcher das magnetische Kopplungselement (16) an den Gewebegreifer (114) sichert; und
 einen externen Haltemagneten (80), wobei wenigstens eines aus dem magnetischen Kopplungselement (16) und dem externen Haltemagneten (80) dazu eingerichtet ist, ein anpassbares magnetisches Feld bereitzustellen.

2. System nach Anspruch 1, wobei das magnetische Kopplungselement (16) einen Permanentmagneten

umfasst.

3. System nach einem der Ansprüche 1 bis 2, wobei der externe Haltemagnet (80) einen Permanentmagneten umfasst.
4. System nach einem der vorhergehenden Ansprüche, wobei das Greifer-Platzierungswerkzeug (10) einen steifen schmalen Schaft (12) umfasst, welcher für ein laparoskopisches Einführen in ein Abdomen eines Patienten eingerichtet ist.
5. System nach Anspruch 4, wobei der Gewebegreifer (114) durch einen Bajonettverschluss (26) an den Schaft (12) gesichert ist, welcher von einem proximalen Ende des Schafts (12) abgenommen werden kann.
6. System nach Anspruch 1, wobei das Gewebegreifer-Platzierungswerkzeug (10) einen Treiber (28) umfasst, welcher mit dem Kolben (150) eingreift und ihn rotiert, um die Klauen (134, 136) zu öffnen und zu schließen.
7. System nach Anspruch 1, wobei das magnetische Kopplungselement (16) dazu eingerichtet ist, von den Klauen (134, 136) getragen zu sein, wenn sie geschlossen sind, und durch Öffnen der Klauen (134, 136) freigegeben zu werden, während der Gewebegreifer (114) an dem distalen Ende des Schafts (12) angebracht verbleibt.
8. System nach einem der vorhergehenden Ansprüche, wobei der Gewebegreifer (114) eine Achse aufweist, welche mit einer Achse des Schafts (12) ausgerichtet ist, so dass der Gewebegreifer (114) und der Schaft (12) gemeinsam als Tandem durch einen laparoskopischen Zugangsdurchgang eingeführt werden können.
9. System nach Anspruch 8, wobei das magnetische Kopplungselement (16) eine Achse aufweist, welche mit den Achsen des Schafts (12) und des Gewebegreifers (114) ausgerichtet ist, so dass das magnetische Kopplungselement (16), der Gewebegreifer (114) und der Schaft (12) zusammen als Tandem durch den laparoskopischen Zugangsdurchgang eingeführt werden können.
10. System nach einem der vorhergehenden Ansprüche, wobei die Länge des Stricks (18) zwischen dem Gewebegreifer (114) und dem magnetischen Kopplungselement (16) anpassbar ist, und wobei der Strick (18) dazu eingerichtet ist, durch das magnetische Kopplungselement (16) gezogen zu werden und selektiv mit einem Verriegelungsmechanismus an dem magnetischen Kopplungselement (16) verriegelt zu werden.

11. System nach Anspruch 10, wobei der Verriegelungsmechanismus mechanisch oder magnetisch antreibbar ist.
12. System nach Anspruch 11, wobei es der Verriegelungsmechanismus dem Strick (18) erlaubt, zu abzugleiten, wenn übermäßige Spannung eingewirkt wird.
13. System nach einem der vorhergehenden Ansprüche, wobei der externe Haltemagnet (80) ein Koppelungselement zum lösbaren Anbringen an einem Tragearm (184) umfasst.
14. System nach Anspruch 13, ferner umfassend einen Tragearm (184), welcher dazu eingerichtet ist, an einen Tisch (T) gesichert zu werden.
15. System nach Anspruch 14, wobei der Tragearm (184) einen Formverriegelungsmechanismus umfasst.

Revendications

1. Système de suspension de tissus comprenant :

un outil de mise en place à dispositif de préhension (10) ayant un arbre (12) avec une extrémité distale ;

un dispositif de préhension de tissu (114) fixé de manière détachable à l'extrémité distale de l'arbre (12), où le dispositif de préhension de tissu (114) comporte une paire de mâchoires de serrage (134, 136) attachées en pivotement, un piston (150) et une liaison (156) qui relie par entraînement le piston (150) aux mâchoires (134, 136), où le piston (150) est configuré pour ouvrir et fermer les mâchoires (134, 136) par l'intermédiaire de la liaison (156) de sorte que le dispositif de préhension de tissu (114) puisse être fermé sur le tissu et rester fermé sur le tissu après avoir été détaché de l'outil de mise en place à dispositif de préhension (10), où le piston (150) comprend des fils externes qui s'engagent sélectivement avec des fils internes sur une surface interne d'une partie de tige (152) du dispositif de préhension de tissu (114), et où une partie de tige (162) est attachée en pivotement et est configurée pour être ouverte et fermée pour dégager et s'engager avec les fils externes et internes ;

un élément de couplage magnétique (16) ;

une attache (18) fixant l'élément de couplage magnétique (16) au dispositif de préhension de tissu (114) ; et

un aimant de suspension externe (80), où au moins l'un de l'élément de couplage magnétique

(16) et de l'aimant de suspension externe (80) est configuré pour fournir un champ magnétique réglable.

2. Système tel que revendiqué dans la revendication 1, dans lequel l'élément de couplage magnétique (16) comprend un aimant permanent.
3. Système tel que revendiqué dans l'une quelconque des revendications 1 et 2, dans lequel l'aimant de suspension externe (80) comprend un aimant permanent.
4. Système tel que revendiqué dans l'une quelconque des revendications précédentes, dans lequel l'outil de mise en place à dispositif de préhension (10) comprend un arbre étroit rigide (12) configuré pour une introduction laparoscopique dans l'abdomen d'un patient.
5. Système tel que revendiqué dans la revendication 4, dans lequel le dispositif de préhension de tissu (114) est fixé à l'arbre (12) par une fixation à baïonnette (26) qui peut être libérée d'une extrémité proximale de l'arbre (12) .
6. Système tel que revendiqué dans la revendication 1, dans lequel l'outil de mise en place à dispositif de préhension de tissu (10) comporte un dispositif d'entraînement (28) qui s'engage avec le piston (150) et le fait tourner pour ouvrir et fermer les mâchoires (134, 136).
7. Système tel que revendiqué dans la revendication 1, dans lequel l'élément de couplage magnétique (16) est configuré pour être porté par les mâchoires (134, 136) lorsqu'elles sont fermées et pour être libéré par l'ouverture des mâchoires (134, 136) tandis que le dispositif de préhension de tissu (114) reste attaché à l'extrémité distale de l'arbre (12).
8. Système tel que revendiqué dans l'une des revendications précédentes, dans lequel le dispositif de préhension de tissu (114) a un axe qui est aligné avec un axe de l'arbre (12) de sorte que le dispositif de préhension de tissu (114) et l'arbre (12) puissent être insérés ensemble en tandem à travers un passage d'accès laparoscopique.
9. Système tel que revendiqué dans la revendication 8, dans lequel l'élément de couplage magnétique (16) a un axe qui est aligné avec les axes de l'arbre (12) et du dispositif de préhension de tissu (114) de sorte que l'élément de couplage magnétique (16), le dispositif de préhension de tissu (114), et l'arbre (12) puissent être insérés ensemble en tandem à travers le passage d'accès laparoscopique.

10. Système tel que revendiqué dans l'une des revendications précédentes, dans lequel la longueur de l'attache (18) entre le dispositif de préhension de tissu (114) et l'élément de couplage magnétique (16) est réglable, et dans lequel l'attache (18) est configurée pour être tirée à travers l'élément de couplage magnétique (16) et verrouillée sélectivement avec un mécanisme de verrouillage sur l'élément de couplage magnétique (16). 5
- 10
11. Système tel que revendiqué dans la revendication 10, dans lequel le mécanisme de verrouillage peut être actionné mécaniquement ou magnétiquement. 10
12. Système tel que revendiqué dans la revendication 11, dans lequel le mécanisme de verrouillage permet à l'attache (18) de glisser si une tension excessive est appliquée. 15
13. Système tel que revendiqué dans l'une des revendications précédentes, dans lequel l'aimant de suspension externe (80) comporte un coupleur pour une fixation amovible sur un bras de support (184). 20
14. Système tel que revendiqué dans la revendication 13, comprenant en outre un bras de support (184) adapté pour être fixé à une table (T). 25
15. Système tel que revendiqué dans la revendication 14, dans lequel le bras de support (184) comprend un mécanisme de verrouillage de forme. 30

35

40

45

50

55

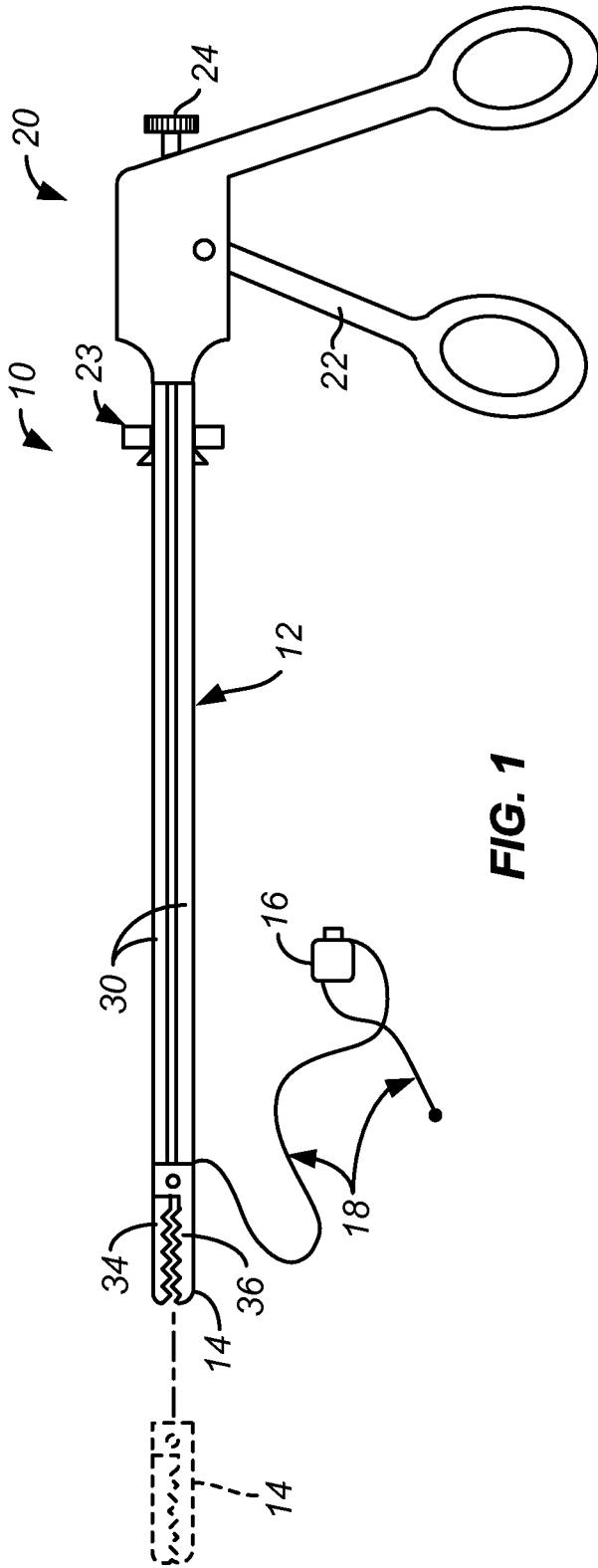

FIG. 1

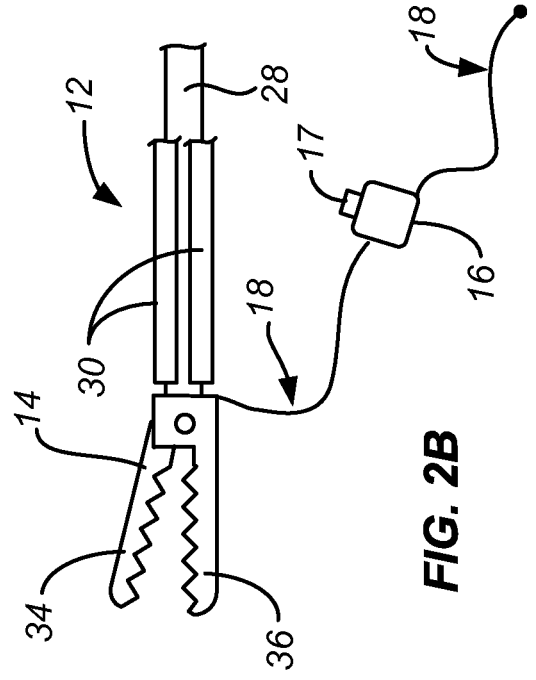

FIG. 2B

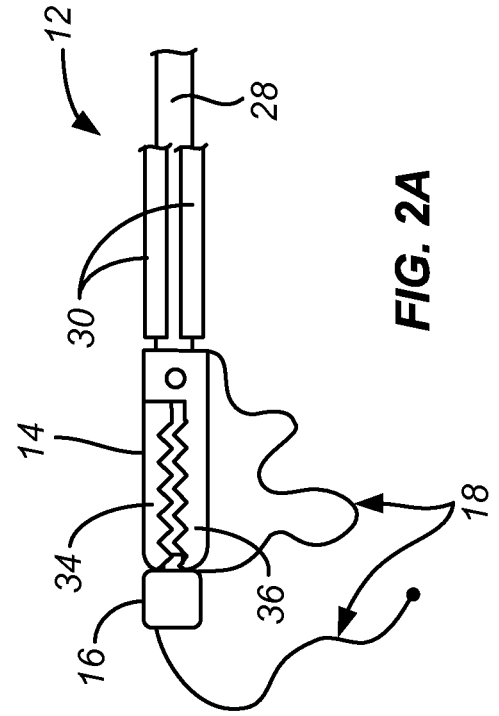
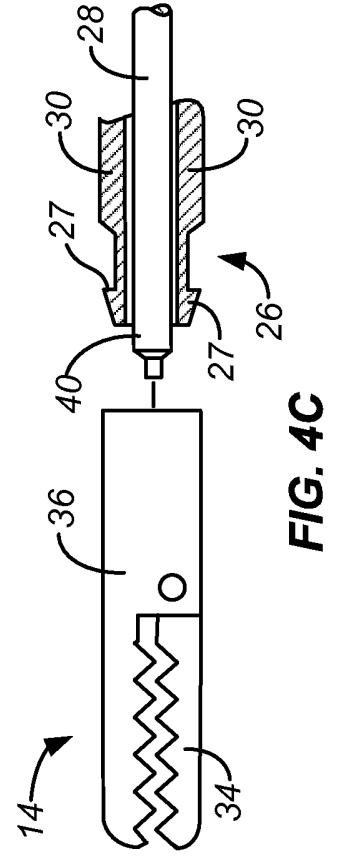
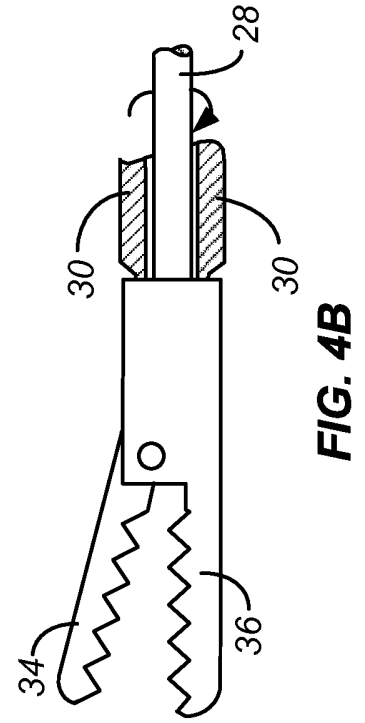
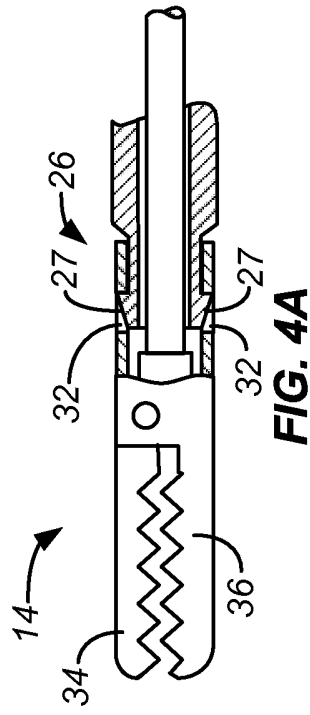
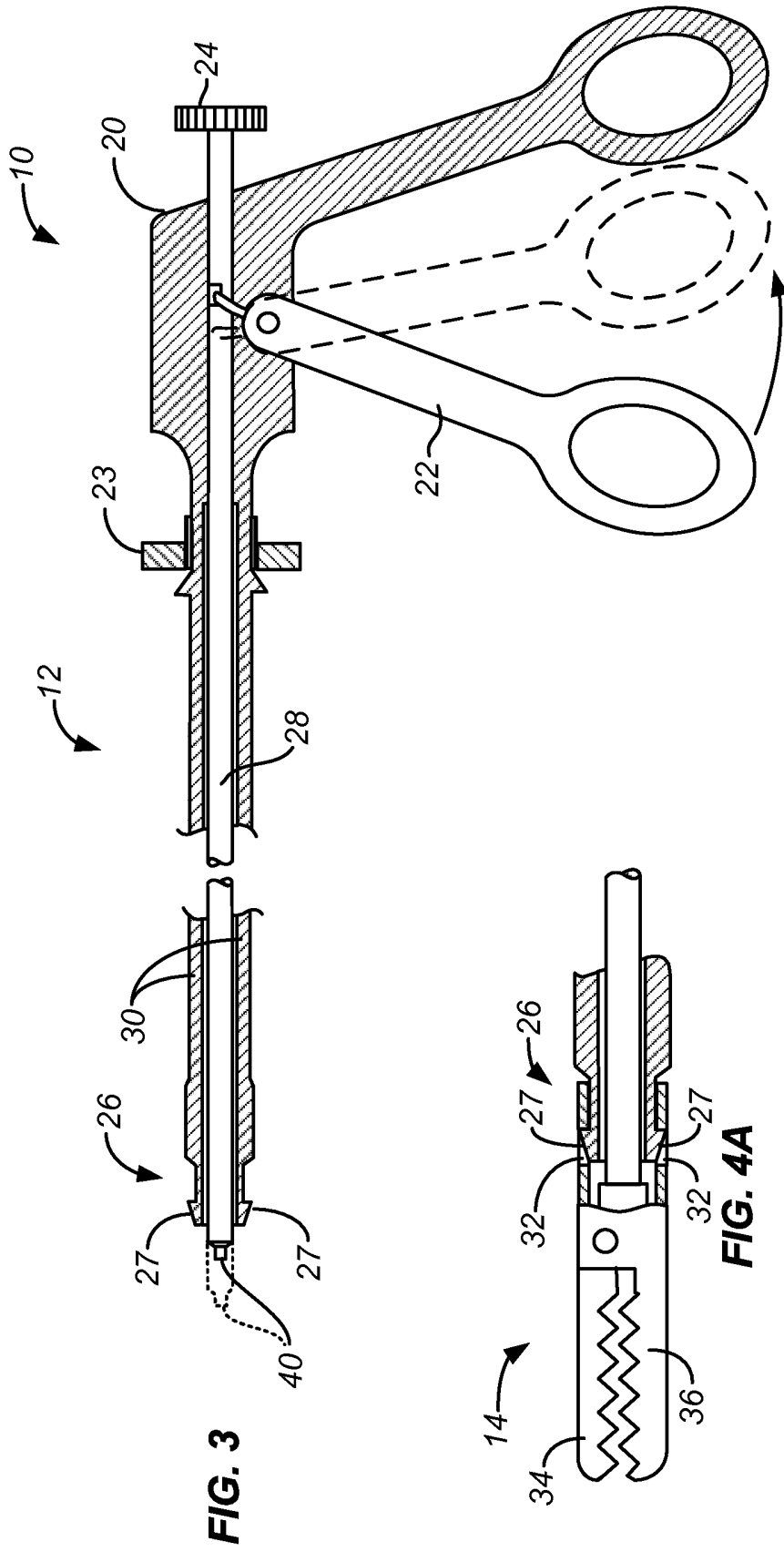

FIG. 2A



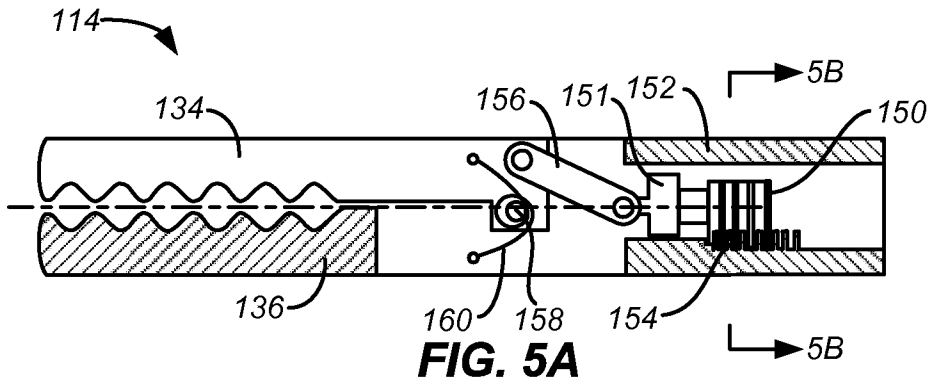

FIG. 5A

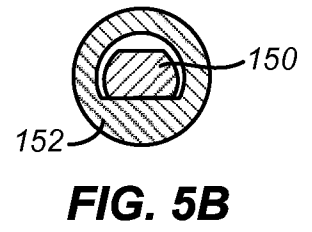

FIG. 5B

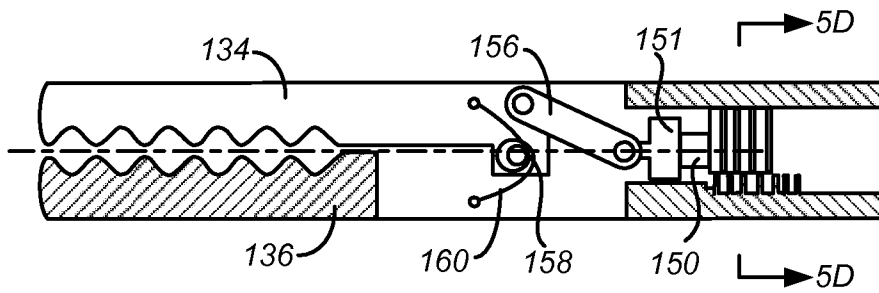

FIG. 5C

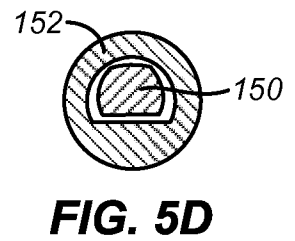

FIG. 5D

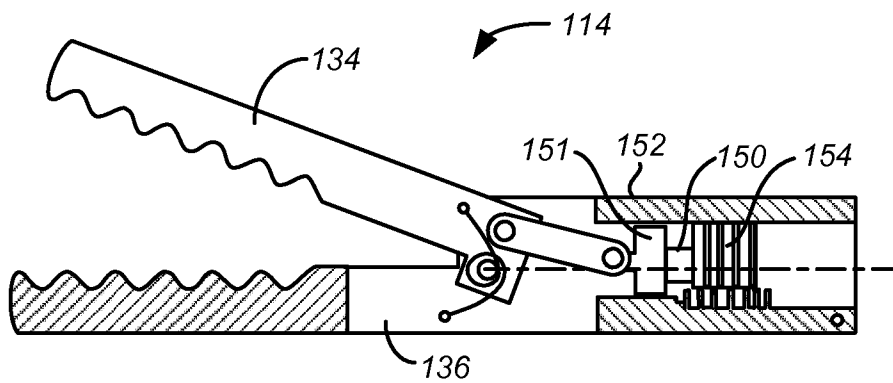

FIG. 5E

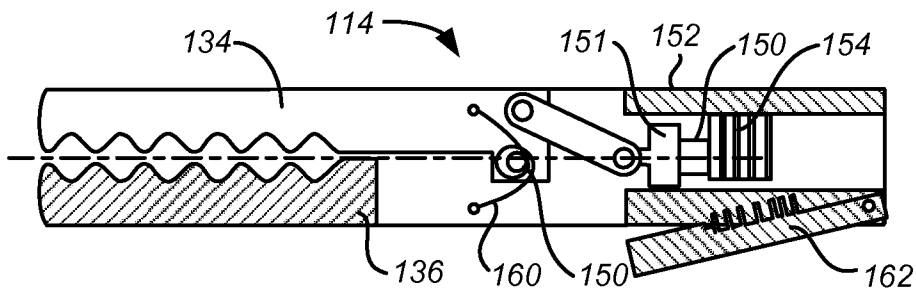

FIG. 5F

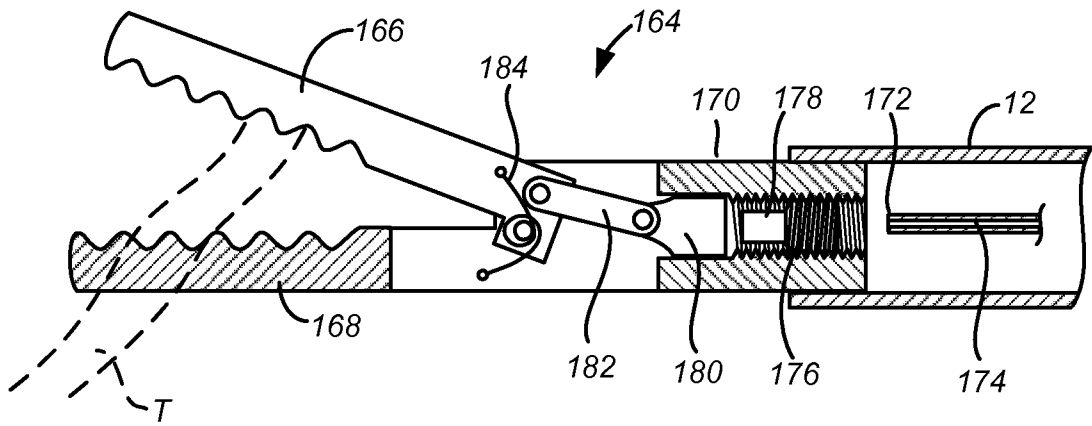

FIG. 5G

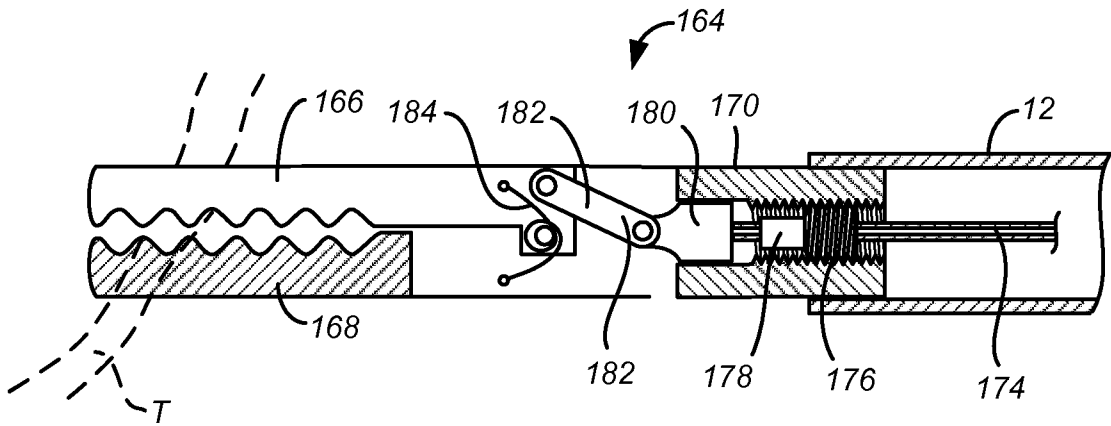

FIG. 5H

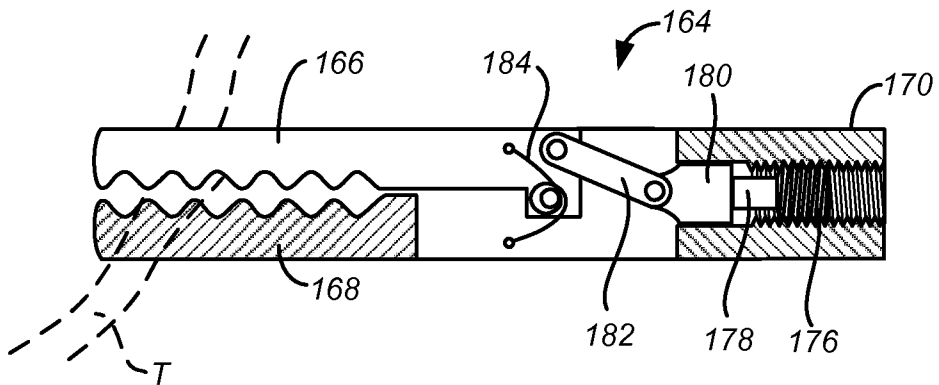

FIG. 5I

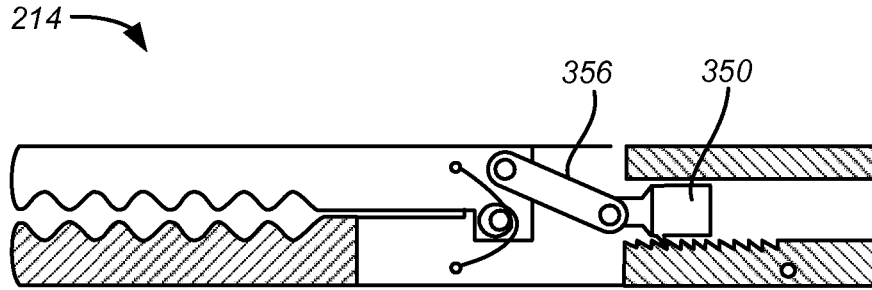

FIG. 6A

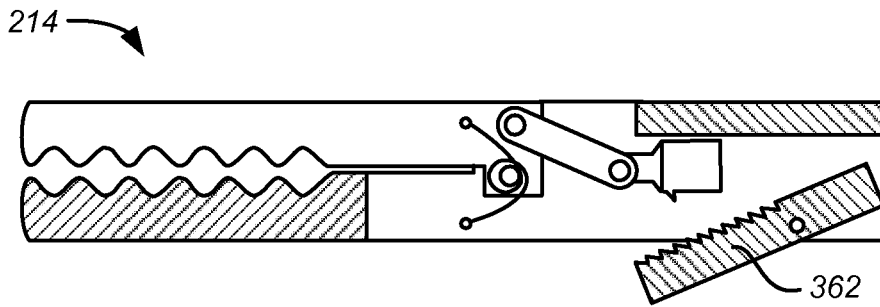

FIG. 6B

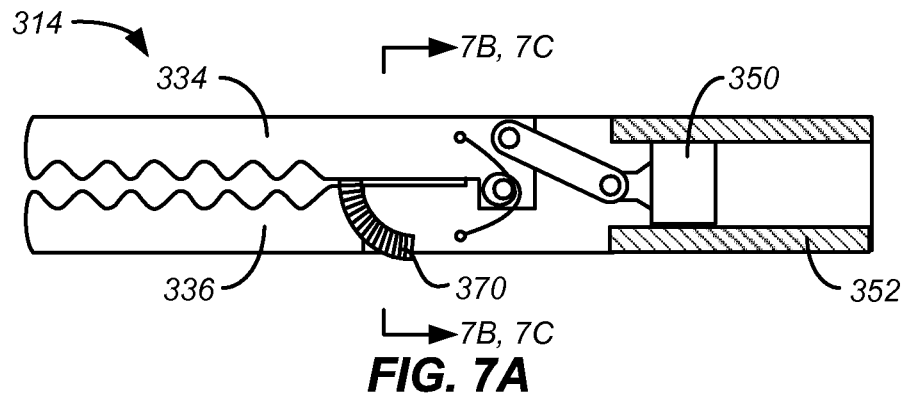

FIG. 7A

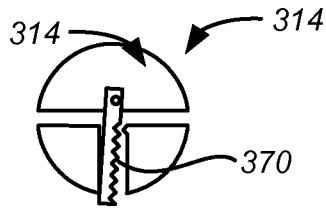

FIG. 7B

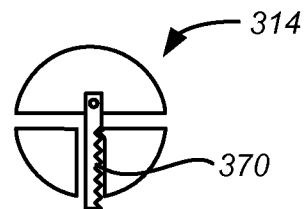

FIG. 7C

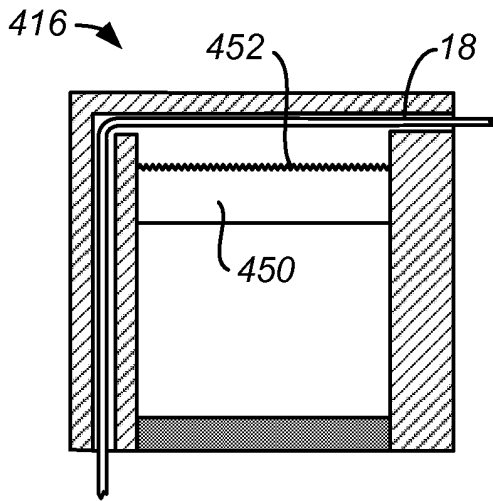

FIG. 8A

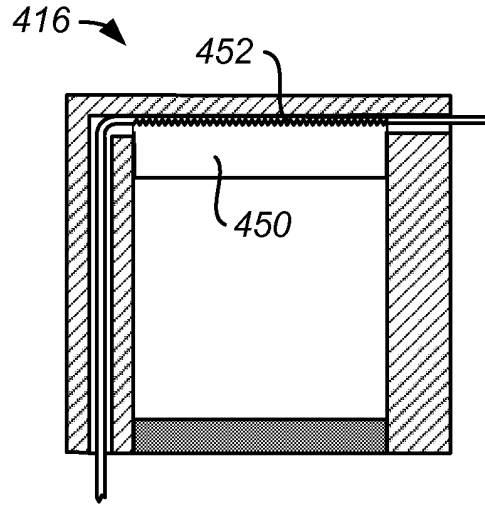

FIG. 8B

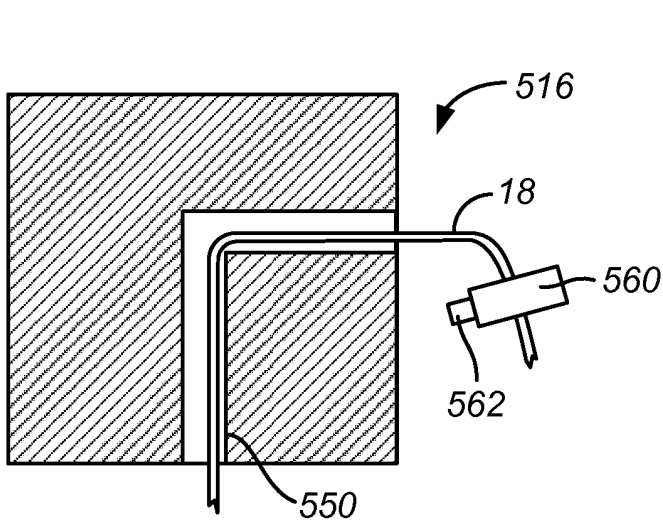

FIG. 9A

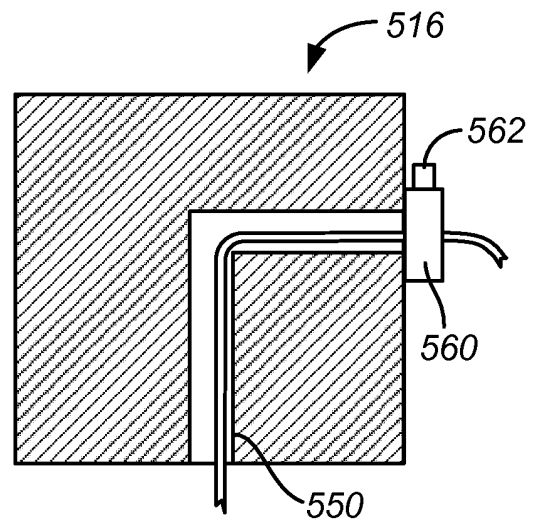

FIG. 9B

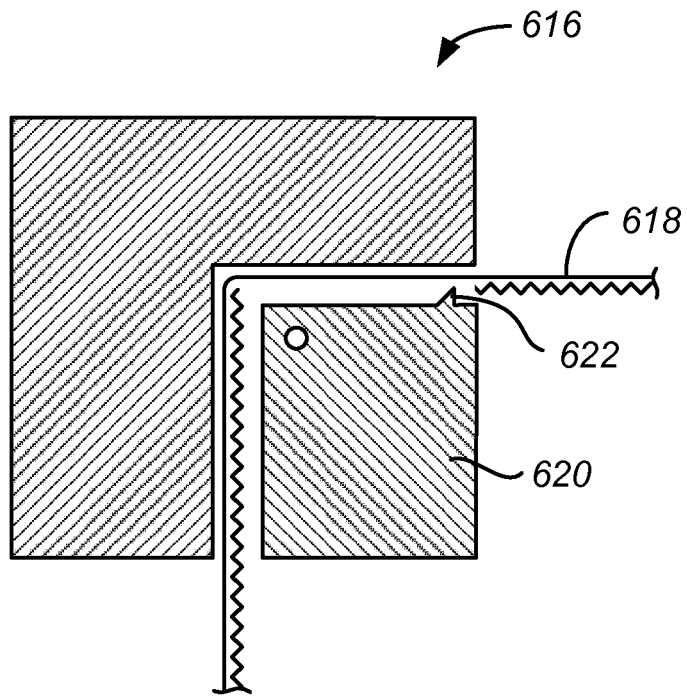

FIG. 10A

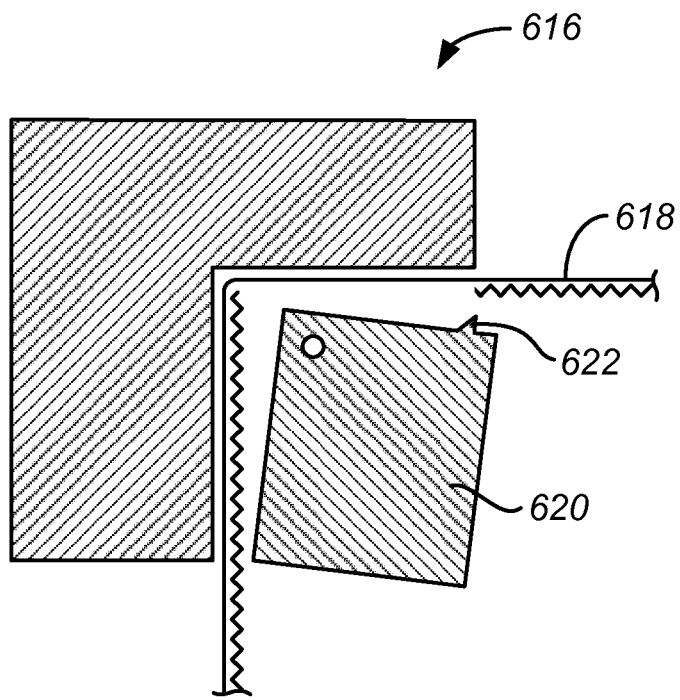

FIG. 10B

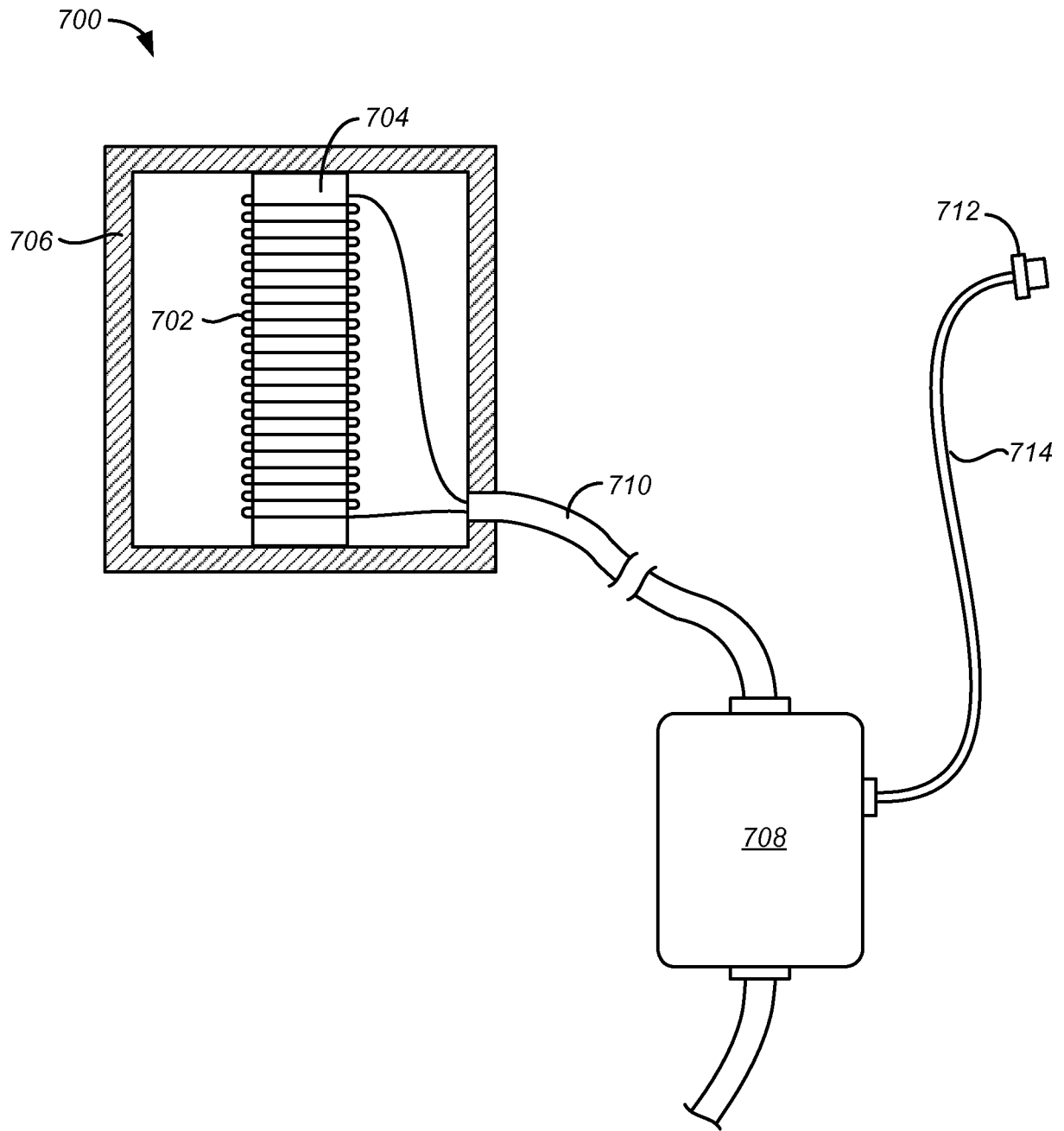

FIG. 10C

FIG. 11A

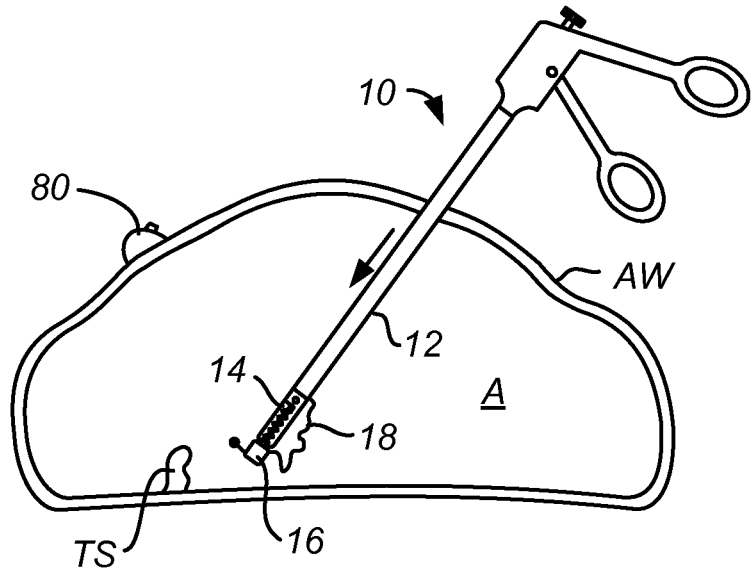

FIG. 11B

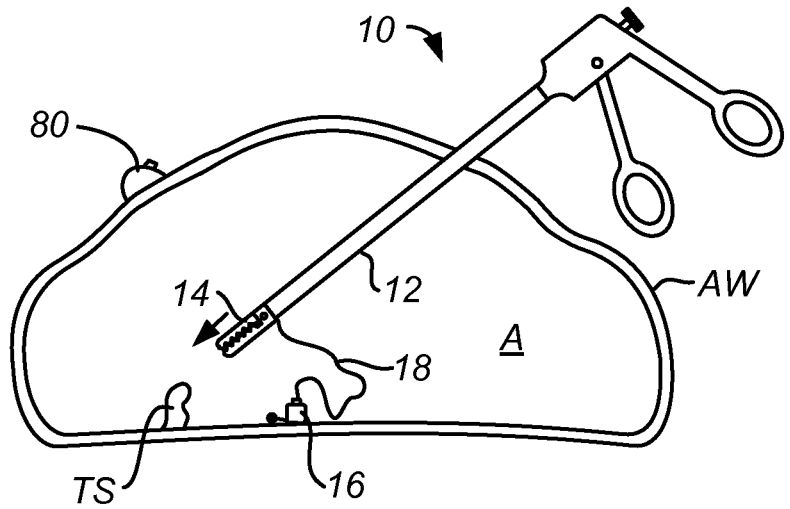

FIG. 11C

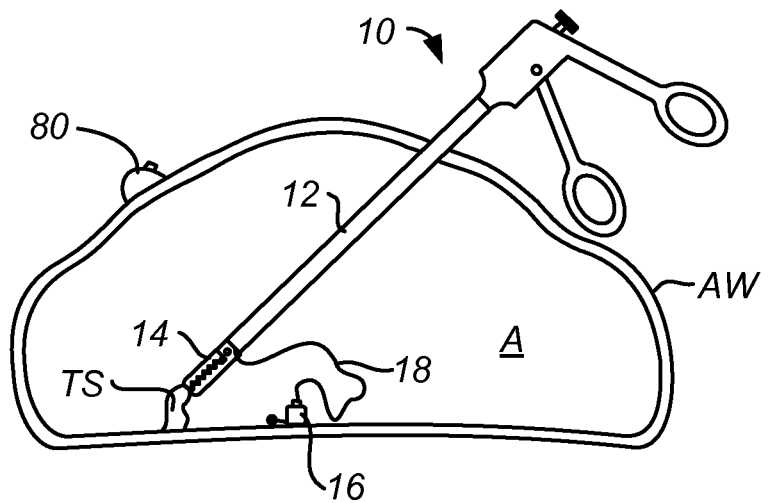

FIG. 11D

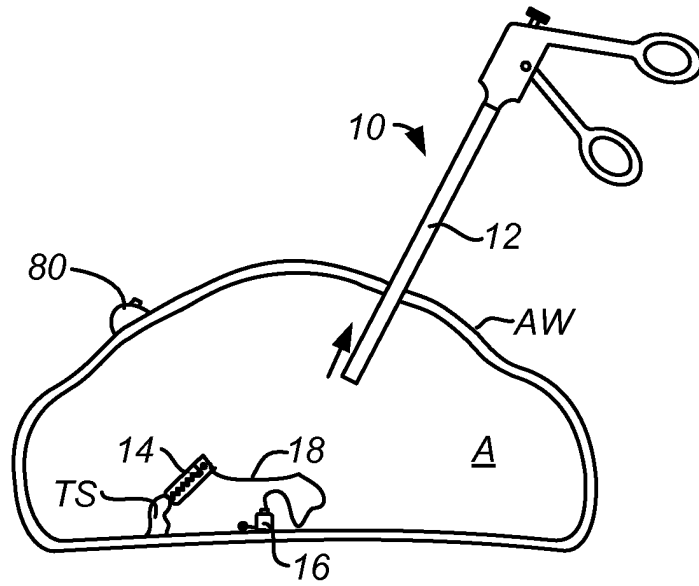

FIG. 11E

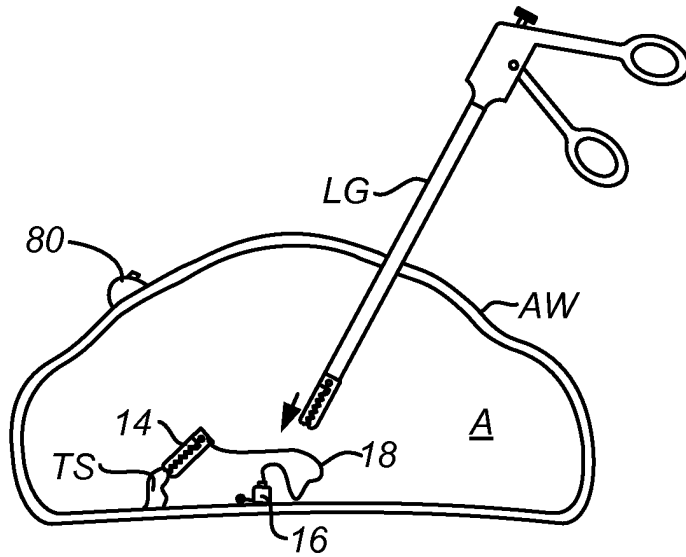

FIG. 11F

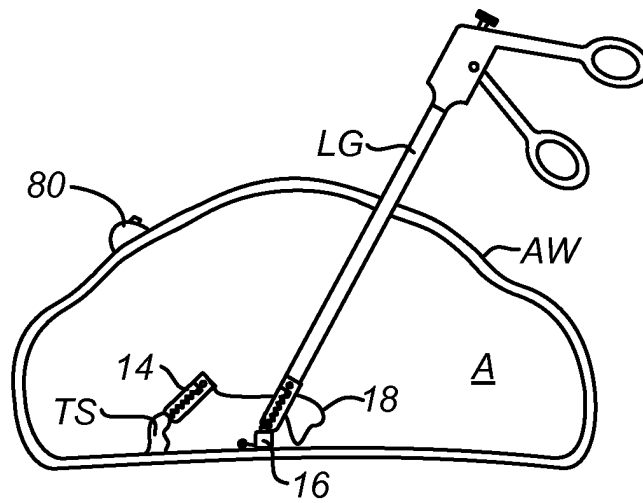

FIG. 11G

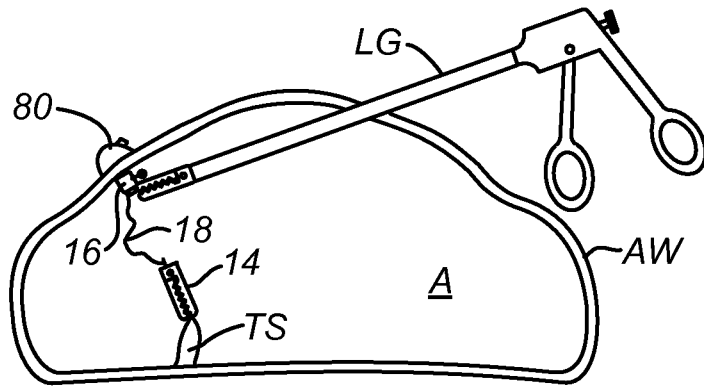

FIG. 11H

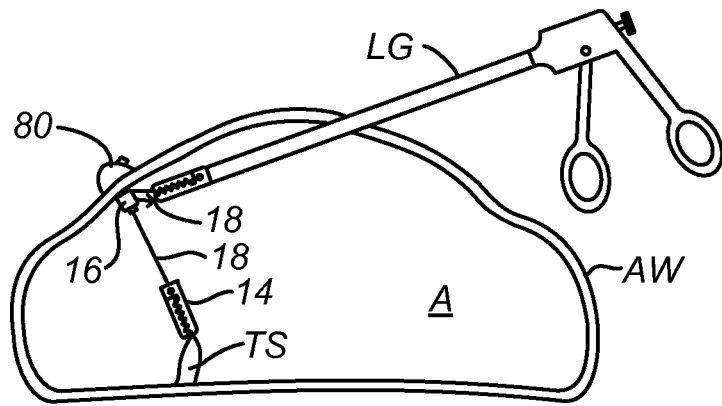
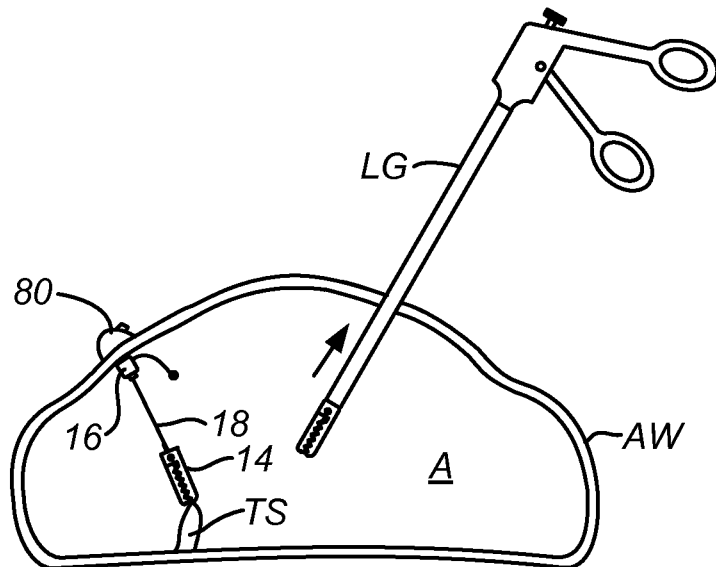

FIG. 11I



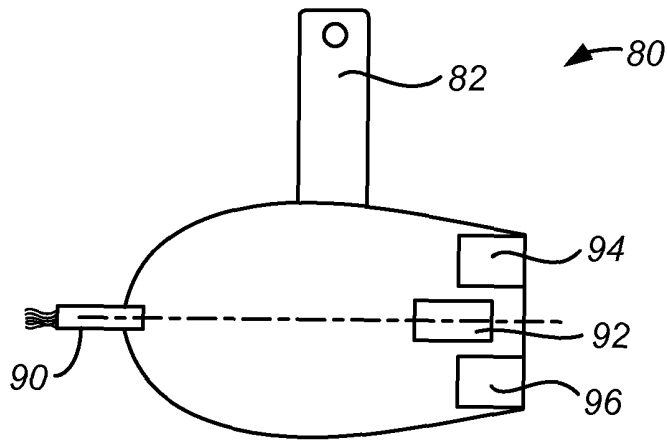

FIG. 12A

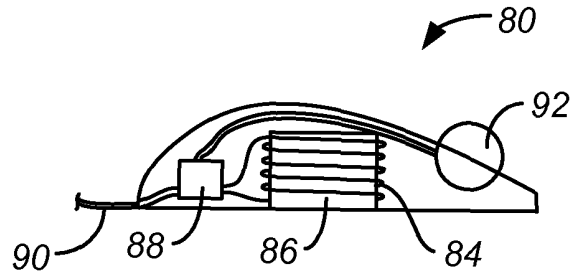

FIG. 12B

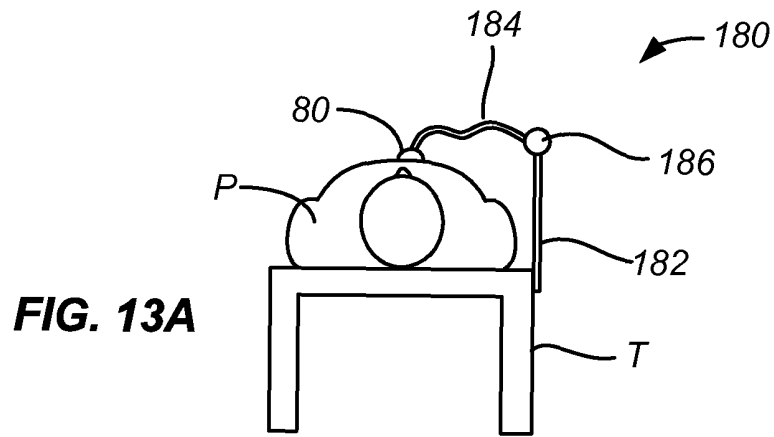

FIG. 13A

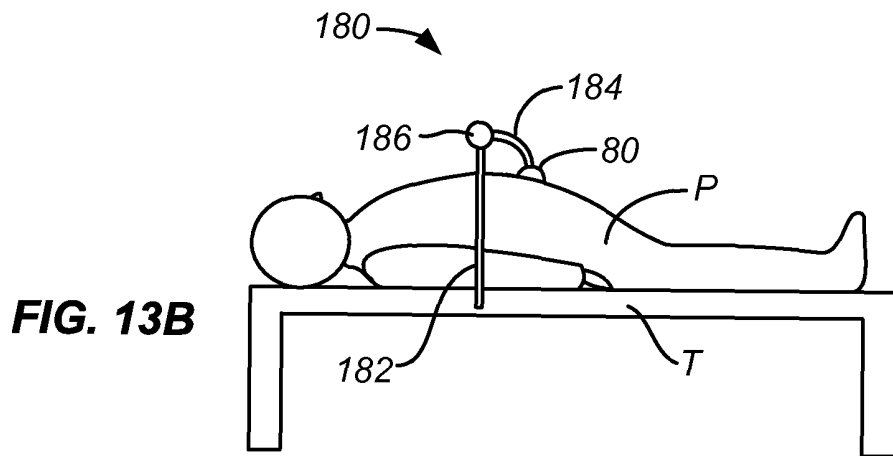

FIG. 13B

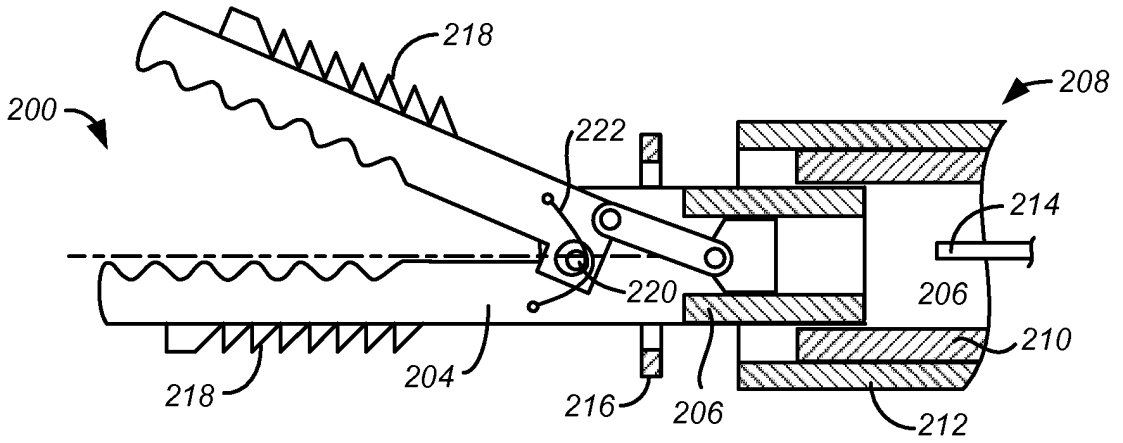

FIG. 14A

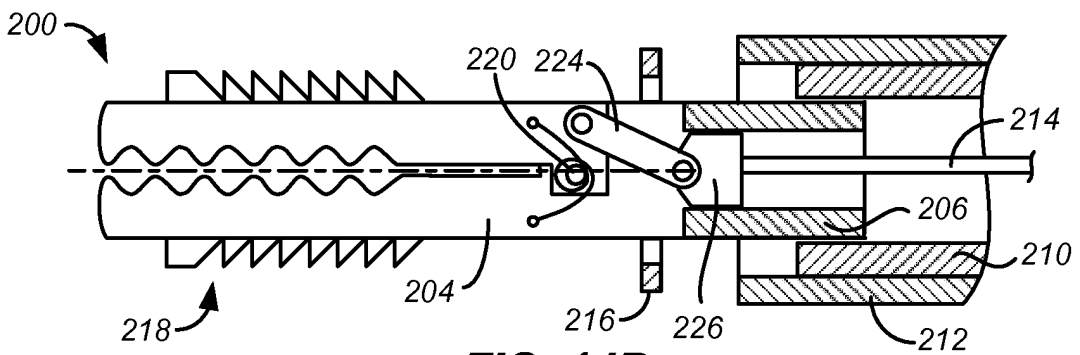

FIG. 14B

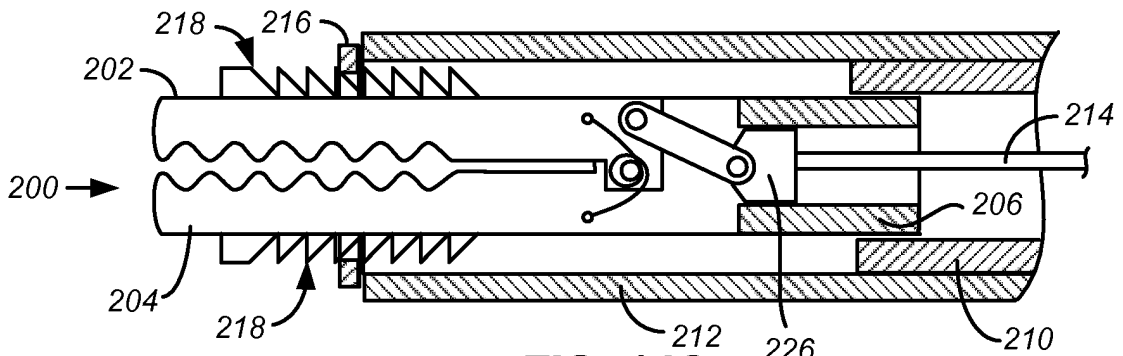

FIG. 14C

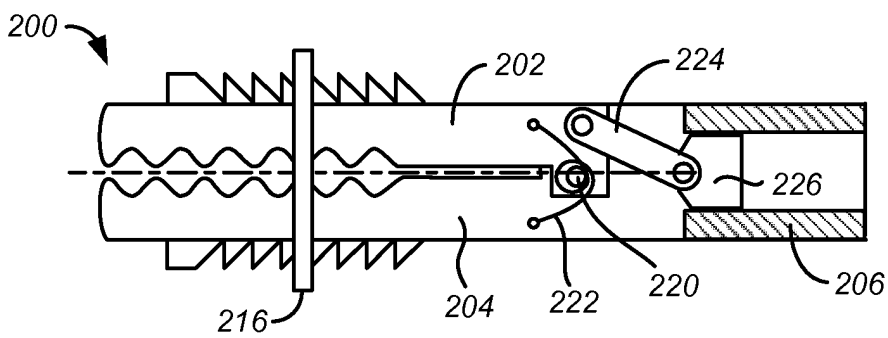

FIG. 14D

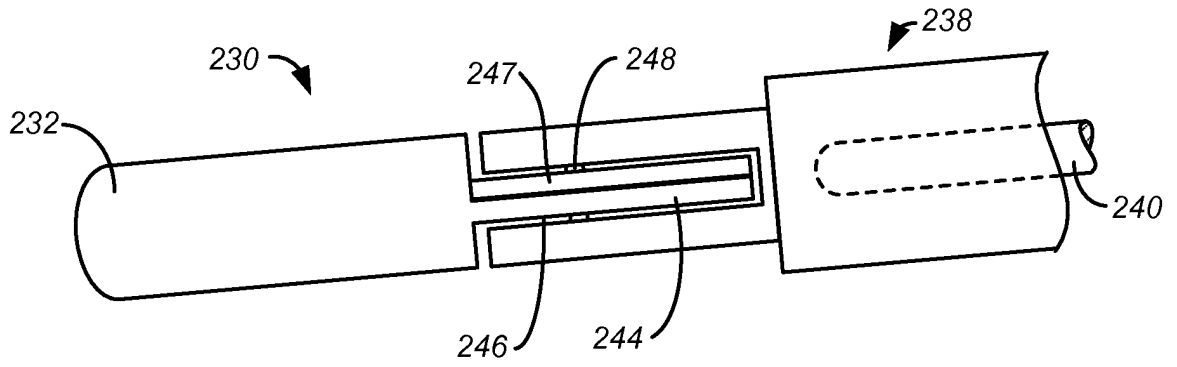

FIG. 15A

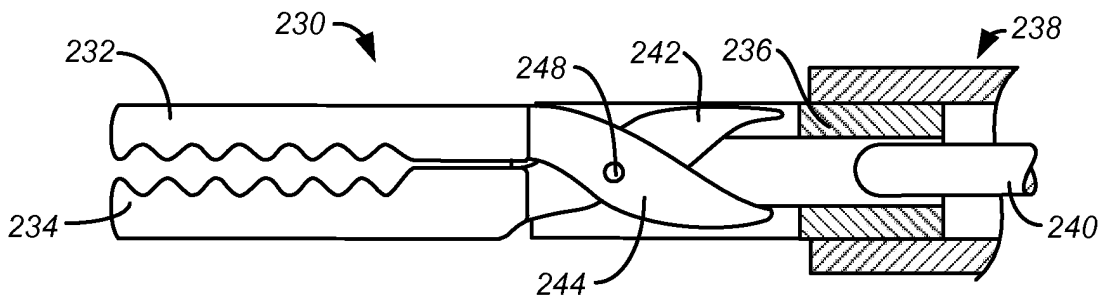

FIG. 15B

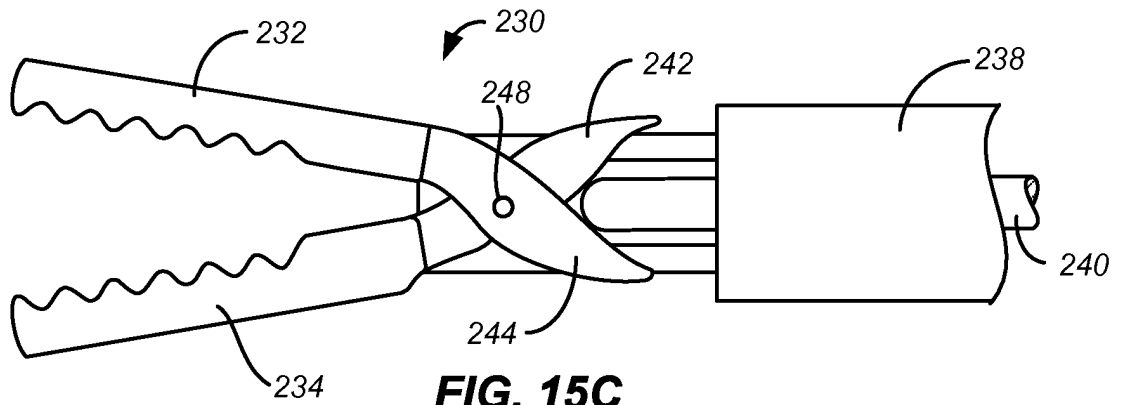

FIG. 15C

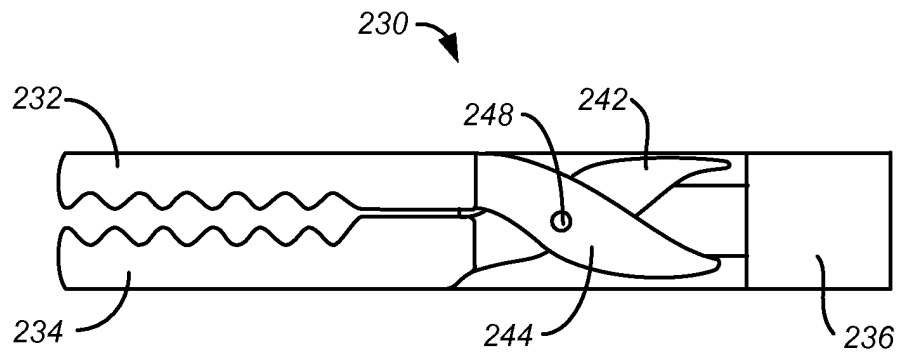

FIG. 15D

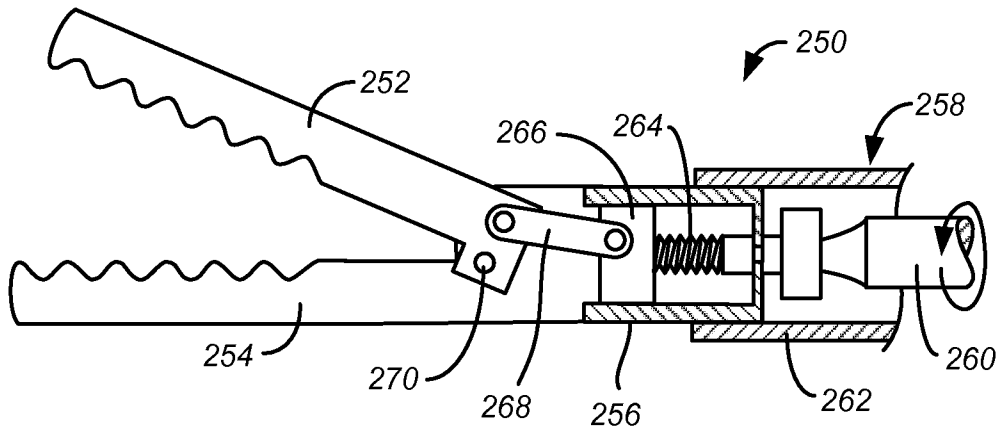

FIG. 16A

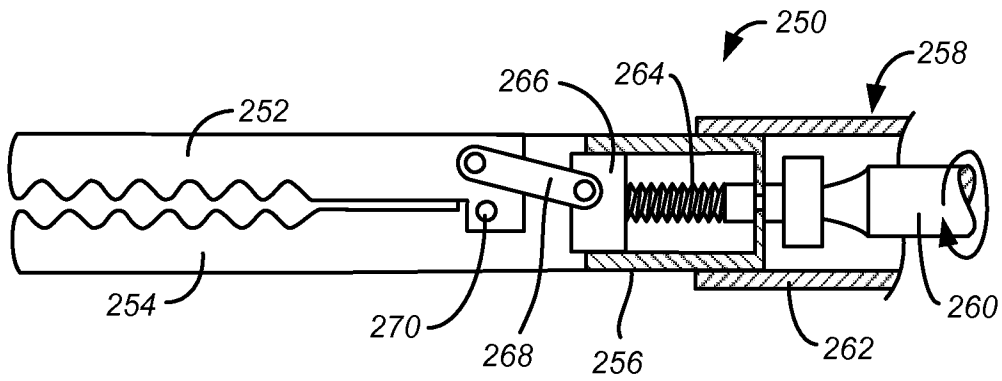

FIG. 16B

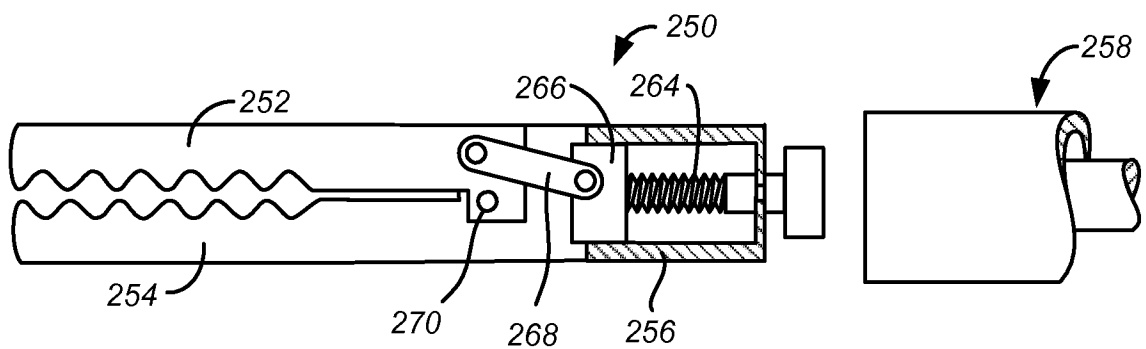

FIG. 16C

REFERENCES CITED IN THE DESCRIPTION

This list of references cited by the applicant is for the reader's convenience only. It does not form part of the European patent document. Even though great care has been taken in compiling the references, errors or omissions cannot be excluded and the EPO disclaims all liability in this regard.

Patent documents cited in the description

- US 20100204727 A [0005]
- US 20090043246 A [0005]
- US 20120088965 A [0005]
- US 20120238796 A [0005]
- WO 2009019288 A [0005]
- US 7169104 B [0006]
- US 7766810 B [0006]
- US 20080171907 A [0006]
- WO 2008089049 A [0006]
- US 20070135678 A1 [0006]
- US 20020107533 A1 [0006]

专利名称(译)	用于磁悬浮组织结构的方法和系统		
公开(公告)号	EP2961334A1	公开(公告)日	2016-01-06
申请号	EP2014757805	申请日	2014-02-11
[标]申请(专利权)人(译)	ROHANINEJAD MOHAMMADREZA		
申请(专利权)人(译)	ROHANINEJAD , MOHAMMADREZA		
当前申请(专利权)人(译)	ROHANINEJAD , MOHAMMADREZA		
[标]发明人	MIRNAJAFI SEYED ALI ROHANINEJAD MOSTAFA ROHANINEJAD MORTEZA ROHANINEJAD MOHAMMADREZA		
发明人	MIRNAJAFI, SEYED, ALI ROHANINEJAD, MOSTAFA ROHANINEJAD, MORTEZA ROHANINEJAD, MOHAMMADREZA		
IPC分类号	A61B17/128 A61B17/00 A61B17/29		
CPC分类号	A61B17/122 A61B17/1227 A61B17/1285 A61B17/29 A61B34/73 A61B2017/00283 A61B2017/00473 A61B2017/00818 A61B2017/00876 A61B2017/2931 A61B2017/2946 A61B17/282 A61B17/2833		
代理机构(译)	博尔特WADE TENNANT		
优先权	61/770159 2013-02-27 US 14/030581 2013-09-18 US		
其他公开文献	EP2961334A4 EP2961334B1		
外部链接	Espacenet		

摘要(译)

一种用于磁悬浮组织的系统包括抓紧器放置工具，组织抓紧器，磁耦合元件和将磁耦合元件固定到组织抓紧器的系绳。抓紧器放置工具用于同时将组织抓紧器和磁耦合元件引入体腔。然后，抓紧器释放磁耦合元件并与目标组织结构接合。然后将组织抓紧器从放置工具上拆下，并使用传统的腹腔镜或其它抓紧器将磁耦合元件接合到外部磁体。