



(11) **EP 1 824 397 B1**

(12) **EUROPEAN PATENT SPECIFICATION**

(45) Date of publication and mention of the grant of the patent:
02.09.2009 Bulletin 2009/36

(21) Application number: **05810160.1**

(22) Date of filing: **28.11.2005**

(51) Int Cl.:
A61B 17/34 (2006.01)

(86) International application number:
PCT/IB2005/003566

(87) International publication number:
WO 2006/059198 (08.06.2006 Gazette 2006/23)

(54) **SYSTEM FOR MINIMIZING LEAKAGE OF A DISTENDING MEDIUM DURING ENDOSCOPIC SURGICAL PROCEDURES**

SYSTEM ZUR MINIMIERUNG VON LECKAGEN EINES SICH AUFWEITENDEN MEDIUMS WÄHREND ENDOSKOPISCHEN CHIRURGISCHEN EINGRIFFEN

SYSTEME DESTINES A REDUIRE LA FUITE D'UN MILIEU DE DISTENSION PENDANT DES OPERATIONS CHIRURGICALES ENDOSCOPIQUES

(84) Designated Contracting States:
AT BE BG CH CY CZ DE DK EE ES FI FR GB GR HU IE IS IT LI LT LU LV MC NL PL PT RO SE SI SK TR

(30) Priority: **30.11.2004 IN DE23922004**

(43) Date of publication of application:
29.08.2007 Bulletin 2007/35

(73) Proprietor: **Kumar, Atul Jaipur 302 004 (IN)**

(72) Inventor: **KUMAR, Alka, Anil Hospital Jaipur 302 004 (IN)**

(74) Representative: **Maury, Richard Philip Marks & Clerk LLP 90 Long Acre London WC2E 9RA (GB)**

(56) References cited:
US-A- 5 545 179 US-A- 5 803 921
US-A1- 2002 016 607 US-A1- 2004 097 793
US-A1- 2004 162 531

EP 1 824 397 B1

Note: Within nine months of the publication of the mention of the grant of the European patent in the European Patent Bulletin, any person may give notice to the European Patent Office of opposition to that patent, in accordance with the Implementing Regulations. Notice of opposition shall not be deemed to have been filed until the opposition fee has been paid. (Art. 99(1) European Patent Convention).

Description

FIELD OF THE INVENTION

[0001] The present invention relates to a system which avoids or minimizes leakage of a distending liquid or gaseous medium by the sides of an endoscopic instrument during endoscopic procedures, such as arthroscopic, hysteroscopic or laparoscopic surgery.

BACKGROUND OF THE INVENTION

[0002] Endoscopic surgery is becoming increasingly popular because it is a minimally invasive form of surgery, it is associated with less pain, and the patients can return back to normal work relatively early with minimal loss of working days.

[0003] In endoscopic surgeries, an endoscope is typically introduced into a body cavity via the natural opening of the cavity or, alternatively, a minute hole is made in the wall of the cavity through which the endoscope is introduced to visualize the interior of the body tissue cavity and to perform endoscopic surgical procedures. For the purposes of the present invention, the term "tissue cavity opening" shall be used to refer to a natural opening of a body tissue cavity opening, via which an endoscopic instrument is introduced. Additionally, the term "tissue cavity opening" shall be used to refer to an incision or hole made in the tissue cavity for passing an endoscopic instrument. For these reasons, endoscopic surgery is also referred to as "key hole" or "minimal access" surgery.

[0004] Endoscopic surgery is primarily related to a tissue cavity. Most endoscopic surgical procedures are carried out on an existing body cavity which is distended or "ballooned up" by filling the cavity with a suitable distending medium, which permits the inner lining of the tissue cavity to be visualized through an endoscope. Hysteroscopy, arthroscopy and laparoscopy are only a few of the routinely performed endoscopic procedures.

[0005] In its natural state, a tissue cavity is a collapsed structure with the cavity walls being in apposition with each other as if kissing each other. Accordingly, if an endoscope is introduced in such a collapsed cavity, no endoscopic visualization is possible unless the cavity is ballooned up by filling it with a transparent fluid. Such ballooning of the tissue cavity is called "cavity distension." No endoscopic procedure can be performed if an adequate distension of the tissue cavity is not achieved and maintained. Cavity distension provides both endoscopic visualization and mechanical distension, which are necessary for the manipulation of endoscopic instruments.

[0006] Besides many other criteria related to patient safety and surgical accuracy, an efficient cavity distension is one in which the distending medium does not leak by the sides of an endoscopic instrument. If leakage occurs, the tissue cavity collapses and adequate mechanical separation of the cavity walls cannot be achieved and the mechanical separation cannot be maintained,

thus making endoscopic surgery difficult or impossible. Accordingly, it is extremely important to prevent the leakage of the distending medium by the sides of an endoscopic instrument.

[0007] For a better understanding of the present invention, a brief description of the basic physics of cavity distension is provided below. Filling the tissue cavity with fluid enables distension of the cavity. Initially, more fluid is pumped than the amount which is extracted from the cavity and, ultimately, the inflow rate is fixed at a level where a desired cavity pressure and distension is achieved. This is termed distension by using "continuous flow irrigation." However, a cavity can also be distended by using the less preferred "non continuous flow irrigation," wherein the cavity is distended by simply instilling fluid into a cavity while there is no outflow tube. This distension by "non continuous flow irrigation" can also be termed "distension by utilizing a static type system." In laparoscopic surgery, the abdominal cavity is only distended by instilling carbon dioxide by the static type of system. Irrespective of the type of distension technique utilized, i.e., distension by "continuous flow irrigation" or distension by using a "static type system," it is important to avoid or at least minimize the leakage of the distending medium by the sides of the endoscopic instrument.

[0008] An endoscope is a cylindrical tube having an outer diameter ranging between 3 to 9 mm approximately. A typical endoscope has four channels. One channel allows passage of a fiber optic telescope while endoscopic instruments are inserted through a second channel. A third channel, also known as the "inflow channel," is used for introducing irrigation fluid into a tissue cavity, the proximal end of this channel ending in a metal adaptor known as the "inflow port," while the distal end of this inflow channel opens near the tip of the endoscope. The inflow port is connectable to an inflow tube which carries sterile irrigation fluid from a fluid source reservoir. A fourth channel, also known as the "outflow channel," allows extracting the waste fluid out of the cavity, the proximal end of this channel ending in a metal adaptor known as the "outflow port," while the distal end of this outflow channel opens near the tip of the endoscope. The outflow port is connectable with an outflow tube which transports the waste fluid from the cavity to a suitable waste fluid collecting reservoir. However, in the static distension system, the outflow port and the outflow channel are missing or not used in the endoscope, and either gas or fluid can be instilled via the inflow channel of the endoscope. A set of fiber optic bundles contained inside the telescope transmit light energy produced by an external light source. This light energy illuminates the walls of the tissue cavity. The image thus formed is carried via a separate set of optical pathways situated inside the telescope. A video camera attached to the eye piece of the telescope forms a clear endoscopic image of the cavity on a TV monitor. The surgeon has to continuously look at the TV monitor all through the endoscopic procedure.

[0009] A brief description of a distending medium leak

occurring by the sides of an endoscope of the prior art is described below. The fluid of gaseous medium which distends a tissue cavity is pressurized and, thus, it may leak by escaping through a potential space located between the endoscope and the tissue cavity opening, if a liquid tight or a gas tight contact is not present between the endoscope and the tissue cavity opening. Such leakage is undesirable and, thus, the terms "cavity leak" and "cavity leakage" (which are used interchangeably) refer to leakage of a distending liquid or gas by the sides of an endoscope, including endoscopic surgical instruments that could enter into the tissue cavity through a cannula or which may be introduced directly (that is without a cannula). The surgical instruments could be shavers, endoscopic forceps, endoscopic scissors, endoscopic tissue retractors, probes and electrodes, among others. Thus, for the purposes of the present invention, the terms "endoscope" and "endoscopic instrument" are used interchangeably, and these terms are intended to include all surgical instruments whether passed directly or through a cannula.

[0010] The mechanism and causes of "cavity leakage" are different for different type of endoscopic procedures. Accordingly, a separate discussion for each type of endoscopic procedure is provided below.

[0011] In arthroscopic surgery, a trocar cannula is initially introduced into a joint cavity and subsequently the trocar is removed from the cannula to allow an endoscopic instrument to be introduced in place of the trocar. The trocar cannula consists of a trocar contained inside a cannula, which is a hollow rigid, usually metallic, cylindrical tube. The trocar is a long solid cylindrical rod, usually metallic, having a pointed or a relatively blunt distal end. A small incision is made in the skin overlying the joint cavity, and the trocar cannula is inserted into the joint cavity by using the pointed end of the trocar. The initial incision created by the pointed tip of the trocar is subsequently dilated by the dilated proximal part of the trocar. The telescope is usually housed in a portal created in the manner just described. A separate portal may also be made in a similar manner to house an outflow tube via which waste fluid would be removed from the joint cavity. A shaver, especially for treatment of a shoulder joint, may also be passed via a portal incorporating a cannula as already described.

[0012] Alternatively, in certain situations such as the knee joint, a shaver may be directly introduced into the joint cavity without using the cannula. For this, a slit is first made in the capsule wall through which the shaver is directly inserted into the joint cavity. Especially at higher intra articular pressures, the distending fluid may leak around the sides of the shaver or around the sides of other endoscopic instruments inserted into the joint cavity. Such leakage is undesirable as it leads to a reduction in the intra articular pressure, which necessitates a greater inflow rate in order to maintain the same intra articular pressure. In addition, if a peristaltic pump is used, for example, on the inflow side, such increased flow rate

could culminate in an increased frequency and amplitude of the cavity pressure pulsations caused by the peristaltic pump, which will ultimately lead to an increased turbulence inside the joint cavity. The cavity leak could also lead to a fluid leakage on the floor, it could also cause extracapsular extravasation of fluid, and it could also impede a surgeon from correctly calculating the total volume of fluid extravasation, as there is no reliable method of measuring the total volume of fluid which spills on the floor. The cavity leakage could also occur if two endoscopes having different outer diameters were interchanged.

[0013] In laparoscopic surgery, the carbon dioxide gas used for distending the abdominal cavity may at times leak around the sides of the endoscope, especially if two endoscopes having different outer diameters are interchanged. Such a leak can also occur if the initial slit given over the fascia, to facilitate the insertion of the trocar cannula, is relatively larger than required.

[0014] In hysteroscopic surgery, fluid might leak through a space present between the hysteroscope and the cervical os, especially if the cervical os is accidentally over dilated or if the cervical os is wide open right from the beginning of the surgery. The term "cervical os" refers to the natural opening of a woman's uterus. Such cavity leakage could make hysteroscopic surgery difficult as well as dangerous.

[0015] Methods for avoiding or minimizing cavity leakage are desirable as they would make the endoscopic procedures easier, safer and would also help in conserving costly distending fluid. A method for preventing or minimizing such leakage is to install a plastic or metallic sheath permanently over the endoscope. Such sheath must not be allowed to slip or to get detached from the endoscope. In physical terms, incorporation of the sheath results in an increase in the effective outer diameter of the endoscope, which reduces or avoids cavity leakage by developing a watertight or a gastight contact between the endoscope and the tissue cavity opening. However, it is impractical and difficult to use such sheaths and the result, in terms of minimizing or avoiding cavity leakage, is also unpredictable.

[0016] Further, if endoscopes must be interchanged during the course of an endoscopic procedure, it is inconvenient, from a practical standpoint, to remove and then install a sheath having a different outer diameter. The incorporation of the sheaths also restricts the maneuverability of the endoscope, thereby requiring greater force to move the endoscope in a to and fro, or rotary, motion.

US 2004/0162531 discloses a flexible tubular sheath according to the preamble of claim 1.

[0017] Accordingly, a need exists for a system which would help in avoiding or minimizing the leakage of a gaseous or liquid distending medium through a space located between an endoscopic instrument and a corresponding tissue cavity opening, so that the maneuverability of the endoscopic instrument is not compromised.

SUMMARY OF THE INVENTION

[0018] The present invention overcomes disadvantages of the prior art, such as those noted above, by providing a system for reducing or minimizing the leakage of a liquid or gaseous distending medium on at least one side of an endoscopic instrument. The present invention also provides for allowing two endoscopic instruments having different outer diameters to be interchanged without the risk of liquid or gaseous leak. The present invention can prevent an endoscopic instrument from accidentally slipping out of a tissue cavity, or from accidentally traversing beyond any desired depth inside a tissue cavity.

[0019] The present invention can be used in a method for regulating the leakage of a distending medium, by increasing or decreasing such leakage of the distending medium. The present invention provides a flexible tubular sheath for preventing leakage of fluid distending media during an endoscopic procedure, comprising a double-wall structure formed of an elastic, polymeric material, wherein: the double-wall structure defines a cavity, the cavity contains a fluid, and the double-wall structure is sized to be installed over an endoscopic instrument, characterised in that the flexible tubular sheath has openings at both ends, the flexible tubular sheath being permanently filled with a predetermined amount of fluid so that when unconstrained, it retains its shape and has substantially uniform inner and outer diameters along its length between the openings, the flexible tubular sheath being configured to be introduced over at least a part of the endoscopic instrument by a rolling motion and then introduced by a rolling motion into a cavity without any change in the predetermined amount of fluid. Preferred and optional features are disclosed in the dependent claims.

[0020] Other features and advantages of the present invention will become apparent from the following description of the invention, which refers to the accompanying drawings.

BRIEF DESCRIPTION OF THE DRAWINGS

[0021] Figure 1 is a photograph of a flexible tubular sheath which is employed with a distending medium management system, according to the present invention.

[0022] Figure 2A illustrates another view of the flexible tubular sheath of Figure 1.

[0023] Figure 2B illustrates an end view of the flexible tubular sheath of Figure 1.

[0024] Figure 3 illustrates the flexible tubular sheath of Figure 1 with the inner surface shown in dashed lines.

[0025] Figure 4 illustrates a schematic cross-sectional view of the flexible tubular sheath of Figure 1.

[0026] Figure 5 illustrates a saggital section of the flexible tubular sheath of Figure 1.

[0027] Figure 6A illustrates the flexible tubular sheath of Figure 1 provided over a distal end of an endoscopic instrument and as part of a distending medium manage-

ment system of the present invention.

[0028] Figure 6B illustrates the flexible tubular sheath of Figure 6A positioned towards the proximal end of the endoscopic instrument.

5 **[0029]** Figure 6C illustrates the flexible tubular sheath of Figure 6B positioned at the proximal end of the endoscopic instrument.

10 **[0030]** Figure 7A illustrates a saggital section through the flexible tubular sheath and the distal end of the endoscopic instrument of Figure 6A.

[0031] Figure 7B illustrates a saggital section through the flexible tubular sheath and the proximal end of the endoscopic instrument of Figure 6C.

15 **[0032]** Figure 8A illustrates a cross-sectional view of the flexible tubular sheath of Figure 7A with a rigid thickening located at the most proximal end of the flexible tubular sheath.

[0033] Figure 8B illustrates a cross-sectional view of the rigid thickening of Figure 8A.

20 **[0034]** Figure 9 illustrates the flexible tubular sheath of Figure 1 housed in the center of an endoscopic instrument and with a black tape over the middle region of the system.

25 **[0035]** Figure 10A illustrates a saggital section through an endoscopic instrument housing the flexible tubular sheath of Figure 1 on its distal end.

[0036] Figure 10B illustrates the endoscopic instrument and flexible tubular sheath of Figure 10A passing through a tissue cavity opening.

30 **[0037]** Figure 10C illustrates the endoscopic instrument and flexible tubular sheath of Figure 10A at a stage subsequent to that of Figure 10B, and illustrating the formation of a distal flexible tubular sheath bulge.

35 **[0038]** Figure 10D illustrates the endoscopic instrument and flexible tubular sheath of Figure 10A at a stage subsequent to that of Figure 10C, and illustrating the longitudinal thickenings.

DETAILED DESCRIPTION OF THE PREFERRED EMBODIMENTS

40

[0039] The term "flexible tubular sheath" as used in the present invention is intended to encompass any double-wall hollow body which is open at both ends and which is filled with a fluid, either a liquid or gas, or a combination of a liquid and gas. The term "flexible tubular sheath" also refers to a flexible containment structure whose walls are made of a strong, relatively thick elastic distensible material, such that the cavity could be filled with only a maximum predetermined volume of liquid or gas beyond which the cavity pressure would rise steeply and the structure would burst. As used in the present invention, the term "flexible tubular sheath" is not limited to a tube, or to a tube having a cylindrical or oval cross-section, but rather the term "flexible tubular sheath" is intended to encompass a structure that has an inner hollow body defined by double walls and filled with a liquid or gas, or a combination of liquid or gas.

[0040] The terms "tissue cavity opening" and "cavity opening" as used in the present invention are interchangeable, and they are intended to encompass a natural opening of a body tissue cavity opening, via which an endoscopic instrument may be introduced. The terms "tissue cavity opening" and "cavity opening" also refer to an incision or hole made in a tissue cavity for passing an endoscopic instrument.

[0041] The term "rigid thickening" as used in the present invention is intended to encompass any rigid or partially rigid portion that is attached to, affixed to, or integral with, at least a flexible portion of the "flexible tubular sheath" as defined above.

[0042] Although the present invention will be described below with reference to an endoscopic instrument having a rigid cylindrical tube which is introduced into a tissue cavity, the invention is not limited to this embodiment and contemplates embodiments which utilize an endoscopic instrument that is flexible, or any other endoscopic instruments that are partially rigid or partially flexible.

[0043] The terms "cavity leak" and "cavity leakage" are used interchangeably in the present invention and they refer to leakage of a distending liquid or gas by the sides of an endoscopic surgical instrument that could enter into the tissue cavity through a cannula or which may be introduced directly (that is without a cannula).

[0044] The terms "endoscope" and "endoscopic instrument" are used interchangeably in the present invention, and these terms are intended to include all surgical instruments whether passed directly or through a cannula into a tissue cavity.

[0045] Referring now to the drawings, where like elements are designated by like reference numerals, Figures 1-5 illustrate a flexible tubular sheath 1 of the present invention which is used in connection with an endoscopic instrument as part of distending medium management system (Figures 6A-10D) of the present invention.

[0046] Flexible tubular sheath 1 of Figures 1-5 comprises a double-wall hollow body, open at both ends, which is filled with a pressurized liquid or a gas 51. The cylindrical body of the present invention is open at both ends. Walls 53 of the flexible tubular sheath 1 are not solid, but are rather double-walled containing pressurized liquid or gas. In an exemplary embodiment, walls 53 are made of an elastic material, for example, a distensible elastic polymeric material. The double-wall body would lose its shape if the liquid or gas 51 (or a combination of liquid and gas) contained in it were to be totally or partially removed.

[0047] The flexible tubular sheath 1 of Figure 1 is similar to a squeezable plastic object which is ordinarily sold as a toy for children. As shown in Figures 1, 2A and 2B, the flexible tubular sheath 1 is a hollow cylindrical tube, open at both ends, the walls of which are filled with fluid. When children hold this toy in their hands, the toy quickly rolls out of their hands and falls on the floor. Thus, it is difficult to hold this toy as it easily rolls out of the hands and this is one of the reason that children enjoy playing

with such a toy.

[0048] It is important to note that, similar to the toy with which children play, the flexible tubular sheath of the present invention only "rolls" out of the hands and does not "slip" out of the hands. There is a difference between "rolling" and "slipping." If the flexible tubular sheath was a conventional solid metallic cylindrical steel rod, then it could only slip out of the hands to fall on the floor. However, such solid structure could not roll out of the hands like the flexible tubular sheath shown in Figures 1, 2A and 2B.

[0049] Figures 2A and 2B show the flexible tubular sheath 1 from two different angles. Figure 3 shows the same flexible tubular sheath 1 but with the inner surface of the flexible tubular sheath shown by dashed lines 2. The outer surface of the flexible tubular sheath is labeled as reference numeral 3.

[0050] Figure 4 is a line diagram showing a cross-sectional view of the flexible tubular sheath 1, the cross-sectional view having been cut perpendicular to the long axis 55 of the flexible tubular sheath. The outer and inner surfaces of the flexible tubular sheath have been labeled as reference numerals 3 and 2, respectively. The closed cavity contained between the inner and the outer surface is labeled 4. Figure 5 is a line diagram showing the cut section of the flexible tubular sheath 1 along the sagittal plane of the flexible tubular sheath. The outer and inner surfaces of the flexible tubular sheath have been labeled as reference numerals 3 and 2, respectively. The closed cavity contained between the inner and the outer surface is labeled as reference numeral 4.

[0051] Figure 6A shows flexible tubular sheath 1 disposed over the distal part of the endoscopic instrument 5. In Figure 6B, the flexible tubular sheath is shown grasped by a hand 6 which attempts to push the flexible tubular sheath towards the proximal end of the endoscopic instrument in the direction of arrow 7. It is assumed that the inner surface 2 of the flexible tubular sheath is stretched over the endoscopic instrument 5 so that the inner surface 2 maintains a sufficiently tight grip on the endoscopic instrument 5 such that, when the hand 6 attempts to push the containment system 1 in the direction of the arrow 7, the flexible tubular sheath can only move by rolling in the direction of arrow 7. Figure 6C shows the flexible tubular sheath 1 over the proximal end of the endoscopic instrument.

[0052] In Figure 7A, the inner surface of the flexible tubular sheath fits snugly and tightly over the endoscopic instrument 5 and is denoted by a thin dashed line 2, while the outer surface 3 is denoted by a thick line 3. In Figure 7B, the inner surface is denoted by a thick line 2, while the outer surface is denoted by a thin dashed line 3. Referring to Figure 6B, when the flexible tubular sheath 1 is pushed by hand 6, the flexible tubular sheath could get displaced in the direction of the arrow 7 only by a rolling motion and not by virtue of its inner surface slipping over the external metallic surface of the endoscopic instrument, because the inner surface 2 is assumed to be tight-

ly stretched over the endoscopic instrument 5.

[0053] Referring back to Figure 7B, the surfaces have interchanged their positions in comparison to Figure 7A, and the same has been made possible by the rolling motion exhibited by the flexible tubular sheath 1. As the walls of the flexible tubular sheath 1 are made of a distensible elastic material, the inner surface 2 fits snugly and tightly over the endoscopic instrument 5 by virtue of the elasticity of the distensible elastic material and also by virtue of the positive pressure inside the cavity 4. Cavity 4 is a closed cavity contained between the outer and inner surfaces of the flexible tubular sheath. As explained later, it is the inherent elasticity of the distensible elastic material which causes the inner surface 2 of the flexible tubular sheath to snugly fit tightly over the endoscopic instrument 5, while the positive pressure inside the cavity 4 may also contribute.

[0054] The flexible tubular sheath 1 of Figure 1 comprises a thin distensible elastic polymeric material having substantial elasticity and a substantial distensibility, which means that the total volume of the cavity 4 could be increased substantially if additional liquid or gas was somehow introduced into the cavity 4. However, as explained below, this is undesirable for the present invention. Referring to Figure 7A and 7B, if additional liquid or gas was introduced inside the cavity 4, the outer surface of the flexible tubular sheath would expand in the direction of arrows 8 and 9, while the inner surface 2 would continue to remain tightly fitted over the endoscopic instrument 5. The system of the present invention requires that the inner surface 2 remain tightly fitted over the endoscopic instrument, mainly by virtue of its inherent elasticity, while the positive pressure inside the cavity 4 could contribute by a limited extent. The flexible tubular sheath walls need to be formed of a sufficiently thick, strong and elastic polymeric material, such that the cavity 4 had a limited maximum distensibility.

[0055] For the purpose of the present invention, the term "limited maximum distensibility" refers to the fact that it should not be possible to inflate the cavity 4 like a balloon, which could be inflated to a substantial volume. In the context of the present invention, the walls of the flexible tubular sheath cavity should be sufficiently thick and strong, such that after minimal volume of liquid or gas is introduced inside the flexible tubular sheath cavity 4, the cavity pressure should start increasing steeply so that the cavity would burst if more fluid was to be introduced. The maximum cavity pressure attained before the cavity bursts in a manner explained above would depend upon the overall strength and thickness of the polymeric material constituting the cavity wall. Thus, for the purpose of the present invention, the term "flexible tubular sheath" refers to a flexible containment structure whose walls are made of a strong, relatively thick elastic distensible material, such that the cavity 4 could be filled with only a maximum predetermined volume of liquid or gas beyond which the cavity 4 pressure would rise steeply. For the system of the present invention, the flexible tubular

sheath cavity could be filled by both liquid or gas, or a combination of liquid and gas.

[0056] As shown in Figures 1, 2A, 2B, 3, 6A, 6B, 6C and 9, the flexible tubular sheath has two ends which look similar. However, in relation to an endoscopic instrument, the flexible tubular sheath has a distal end and a proximal end. Referring to Figures 7A and 7B, the flexible tubular sheath has two ends, the end near to the tip of the endoscopic instrument 5 is being termed as the "distal end" and the part of the flexible tubular sheath nearest to the proximal part of the endoscopic instrument (that is, the part of the endoscopic instrument which always remains outside the tissue cavity) is termed the "proximal end" of the flexible tubular sheath.

[0057] It could be difficult to install the flexible tubular sheath over the endoscopic instrument, especially if the flexible tubular sheath were to be made of a strong thick distensible elastic polymeric material. Thus, by suitable mechanical means, and in accordance with the present invention, a non-distended flexible tubular sheath is initially installed over a plastic or metallic hollow cylindrical tube whose inner diameter is greater than the outer diameter of the endoscopic instrument 5. The plastic or metallic tube for housing the flexible tubular sheath is termed "flexible tubular sheath applicator" (not shown). The flexible tubular sheath applicator also has two ends, a proximal end and a distal end. The proximal flexible tubular sheath applicator end corresponds to the prospective proximal flexible tubular sheath end, while the distal flexible tubular sheath applicator end corresponds to the prospective distal flexible tubular sheath end.

[0058] The endoscopic instrument 5 is inserted into the flexible tubular sheath applicator so that the proximal end of the flexible tubular sheath applicator contacts the proximal part of the endoscopic instrument. Subsequently, the proximal end of the flexible tubular sheath is strongly held and anchored via suitable mechanical means, while the distal end of the flexible tubular sheath applicator is pulled away distally, in a direction away from the tip of the endoscopic instrument. Upon completion of such maneuver, the flexible tubular sheath snugly and tightly fits over the endoscopic instrument. As explained in more detail below, the flexible tubular sheath has to be installed on a specific location over the endoscopic instrument. Thus, it could be helpful if the length of the flexible tubular sheath applicator was equal to the length of the endoscopic instrument so that, when the proximal end of the flexible tubular sheath applicator touched the proximal end of the endoscopic instrument, the distal flexible tubular sheath end was in exact apposition with the distal end, i.e., the tip opening of the endoscopic instrument. Thus, in a preferred embodiment, deflated flexible tubular sheath is initially housed over a predetermined location over the flexible tubular sheath applicator, so that the flexible tubular sheath could ultimately be transferred to a predetermined specific location over the endoscopic instrument.

[0059] The distending medium management system

of the present invention requires that the endoscopic instrument, with the flexible tubular sheath attached to it, roll through a tissue cavity opening and never be forced to slip through the tissue cavity opening. If the containment system, instead of rolling, would be made to slip in a to and fro direction through the tissue cavity opening, this would require the flexible tubular sheath cavity 4 to be filled with a relatively greater volume of fluid such that an adequate indentation on the outer surface of the flexible tubular sheath, which facilitates the rolling motion, is not allowed to develop. In this situation, the entire outer surface 3 would have a substantial permanent convexity due to which the flexible tubular sheath could only slip and not roll. The point of maximum convexity would be at the mid point of the flexible tubular sheath along its long length. However, this would create problems. The leak would not be properly sealed while the proximal or the distal ends of the flexible tubular sheath were in contact with the tissue cavity opening because proximal or the distal ends of the flexible tubular sheath would have a relatively smaller outer diameter in comparison to the central point of maximum convexity. It could be relatively more difficult to move the endoscopic instrument in a to and fro direction while the mid part of the flexible tubular sheath was in apposition with the tissue cavity opening, opening, due to mechanical resistance. The point of maximum convexity could also lacerate or over-dilate the tissue cavity opening.

[0060] In physical terms, if a relatively over-distended flexible tubular sheath is made to slip through the tissue cavity opening, the force of indentation which develops between the outer surface of the flexible tubular sheath and the inner surface of the tissue cavity opening varies during a linear to and fro movement. The force is maximum while the central part having maximum convexity is in apposition with the tissue cavity opening and minimum when the two ends of the flexible tubular sheath participate in apposition. Thus, the surgeon would have to apply a variable force while moving the endoscopic instrument in a to and fro direction, if the flexible tubular sheath were to slip instead of roll. For these reasons, the flexible tubular sheath should never be allowed to slip in and out of the cavity, but instead it should be allowed to exhibit a rolling motion. Even if the convexity of the flexible tubular sheath were to be minimized by using a thicker and a stronger polymeric material, considerable friction could be encountered if the flexible tubular sheath was made to slip through the tissue cavity opening.

[0061] The cavity 4 could be pre-filled with an adequate volume of fluid, the volume being less than the maximum volume of fluid which the cavity 4 can conveniently accommodate. The concept of "maximum flexible tubular sheath cavity volume" is discussed below. When such a partially distended flexible tubular sheath enters into the tissue cavity opening, the distal end of the flexible tubular sheath cavity 4 collapses after being squeezed by the inner surface of the tissue cavity opening, thus some small volume of fluid from the distal end of the flexible

tubular sheath cavity 4 enters into a proximal part of the flexible tubular sheath cavity 4, thus increasing the overall size of the proximal part of the flexible tubular sheath cavity. This allows a relatively more tight contact between the tissue cavity opening and the outer surface of the flexible tubular sheath, which helps in initiating a rolling motion for the flexible tubular sheath. However, if the flexible tubular sheath repeatedly rolls in a to and fro direction, the outer surface of the flexible tubular sheath may accidentally slip over the tissue cavity opening instead of rolling. The unwanted accidental slipping could occur more frequently if the flexible tubular sheath cavity was filled with an inadequate volume of fluid. Such slipping may result in the flexible tubular sheath being completely detached from the endoscopic instrument in a distal direction, or the flexible tubular sheath may even be displaced to an extreme proximal position with respect to the endoscopic instrument, and in such a situation the leakage may no longer be minimized. The solution to this problem is set forth in the following paragraph.

[0062] Referring to Figures 8A and 8B a "rigid thickening" or "rigid portion" could be introduced on the inner surface 2 of the flexible tubular sheath along a transverse plane at right angles to the long length of the flexible tubular sheath. In an exemplary embodiment, the rigid thickening of the present invention could be in the form of a non-stretchable, sufficiently strong thread impregnated in the wall of the inner surface near its proximal end. In another exemplary embodiment, the rigid thickening of the present invention may be a thin metallic wire. In yet another exemplary embodiment, the rigid thickening may also be a localized circular thickening of the polymeric material constituting the flexible tubular sheath wall. The part of the inner surface which is in contact with the thickening resists any distension due to the rigid thickening. As suggested by the term "rigid thickening," the flexible tubular sheath cannot distend along the point of attachment or impregnation with the rigid thickening.

[0063] Referring to Figure 8A, the rigid thickening is located at a point 10. The rigid thickening is denoted by a dotted oval line 11. The location of point 10 depends upon the length of the flexible tubular sheath and the overall length of the endoscopic instrument. When the flexible tubular sheath is introduced by the flexible tubular sheath applicator on the endoscopic instrument, the rigid thickening should be located at the most proximal end of the flexible tubular sheath. Figure 8B shows a cross-sectional view at point 10 wherein the rigid thickening is denoted by a thick circular line 2. Referring to Figure 8A, the flexible tubular sheath cannot roll in a distal direction because the rigid thickening does not allow the same. Again, referring to Figure 8A, the location of point 10 is chosen so that the distal most part of the flexible tubular sheath just falls short of the tip of the endoscopic instrument. The rigid thickening 11 does not allow the flexible tubular sheath to become detached from the endoscopic instrument. The rigid thickening 11 helps in firmly anchoring the flexible tubular sheath to the endoscopic instru-

ment, such that the flexible tubular sheath never slips in a distal direction with respect to the distal end of the endoscopic instrument.

[0064] When an endoscopic instrument housing with a flexible tubular sheath passes into the tissue cavity opening, an indentation is created over the outer surface of the flexible tubular sheath cavity because the walls of the tissue cavity opening press over the flexible tubular sheath cavity 4. Referring to Figure 9, a black adhesive tape is applied around the flexible tubular sheath disposed on the endoscopic instrument 5, so that an indentation is produced on the outer surface of the flexible tubular sheath cavity. The flexible tubular sheath has two distinct bulges, distal and proximal to the point of application of the tape. These bulges are termed the distal flexible tubular sheath bulge 15 and the proximal flexible tubular sheath bulge 14, respectively. The indentation produced as a result of a relatively tight application of the tape is symbolic of the impingement caused by the tissue cavity opening upon the flexible tubular sheath and this site of impingement is termed "indentation site" 16 (Figures 10B-10D). Thus, the distal flexible tubular sheath bulge and the proximal flexible tubular sheath bulge are invariably present on two sides of an indentation site.

[0065] Even if a relatively small volume of fluid were to be present inside the flexible tubular sheath cavity 4, the impingement at the indentation site could be enough to avoid cavity leakage, but it may not be enough to guarantee rolling motion for the flexible tubular sheath. If the outer surface 3 is made rough in the prospective site of indentation, a more effective grip could be established between the outer surface 3 and the tissue cavity opening and this could guarantee a rolling motion for the flexible tubular sheath even if relatively less fluid was present inside the flexible tubular sheath cavity 4. In an exemplary embodiment, the outer surface 3 could be made rough by incorporating small circular stipples on the outer surface. For example, parallel circular elevated ridges could be incorporated in the outer surface 3, such ridges lying in transverse plane at right angles to the long axis of the flexible tubular sheath. The parallel circular ridges should not be substituted by parallel longitudinal ridges, as the same would not establish an efficient grip between the outer surface of the flexible tubular sheath and the tissue cavity opening. Thus, a rough outer surface enhances the rolling motion for the flexible tubular sheath. As the flexible tubular sheath moves in a to and fro direction, the inner and the outer surfaces repeatedly interchange positions, meaning that the outer surface may also become the inner surface and vice versa. In the previous paragraphs it has been shown that the location of the indentation site should remain constant in relation to the outer surface. Thus, only that part of the outer surface needs to be made rough which is destined to be prospectively related to the indentation site.

[0066] Figure 10A shows flexible tubular sheath 1 installed over the distal part of endoscopic instrument 5. As noted, the term flexible tubular sheath refers to a flex-

ible tubular sheath whose cavity 4 has been filled with a certain volume of fluid beyond which it would not be practically possible to pass an endoscopic instrument housing the flexible tubular sheath into the tissue cavity opening without deflating the flexible tubular sheath cavity. This certain volume of fluid is termed "lesser flexible tubular sheath cavity volume." Dashed lines 12 (Figure 10A) represent a flexible tubular sheath cavity which has been distended to a "maximum possible volume capacity," beyond which it may not be possible to distend the flexible tubular sheath cavity any more from a practical point of view, and beyond which the flexible tubular sheath cavity pressure rises steeply and beyond which the flexible tubular sheath cavity could even burst. The maximum possible volume capacity is termed "maximum flexible tubular sheath cavity volume." From a practical point of view, the term "maximum flexible tubular sheath cavity volume" relates to a fluid volume beyond which the surgeon finds it practically difficult to distend the flexible tubular sheath cavity, i.e., if the surgeon were to manually do the same on his own. The concept "maximum flexible tubular sheath cavity volume" could exist only if the flexible tubular sheath cavity was made of a sufficiently thick, strong and elastic polymeric material. If the flexible tubular sheath cavity was made up of a relatively thinner, a weaker elastic material, then the relevance of the concept "maximum flexible tubular sheath cavity volume" would be greatly reduced. An endoscopic instrument housing a flexible tubular sheath cavity filled to a "maximum flexible tubular sheath cavity volume" cannot be pushed through a narrow tissue cavity opening. Also, any flexible tubular sheath cavity volume smaller than the "maximum flexible tubular sheath cavity volume" at which the endoscopic instrument could be directly introduced through the tissue cavity opening is termed "lesser flexible tubular sheath cavity volume." Figure 10B shows an endoscopic instrument housing a flexible tubular sheath distended to a lesser flexible tubular sheath cavity volume being pushed through a tissue cavity opening 13. The inner walls of the tissue cavity opening 13 squeeze the distal end of the flexible tubular sheath at the indentation site 16.

[0067] Referring to Figure 10C, as the endoscopic instrument is pushed further into the tissue cavity opening 13, the pressure inside the proximal flexible tubular sheath bulge increases, as a result of which some fluid is squeezed in the direction of the distal end of the flexible tubular sheath cavity, so that a distal flexible tubular sheath bulge 15 develops. In such case, it is always possible to completely withdraw the endoscopic instrument out of the tissue cavity opening 13 as the sequence of events stated above could also be replicated in an opposite manner. In this situation, the endoscopic instrument could always be withdrawn or accidentally come out of the tissue cavity opening. However, some surgeons might not like the endoscopic instrument to accidentally totally come out of the tissue cavity opening. The solution to this problem is shown in Figure 10D. The rigid

thickening 11 is located at the proximal most part of the flexible tubular sheath in Figures 10B, 10C and 10D. However, in Figures 10B and 10C, the flexible tubular sheath is distended to a "lesser flexible tubular sheath cavity volume," thus it could be directly introduced and removed from the tissue cavity opening. In Figure 10D, the flexible tubular sheath cavity was initially filled to a "lesser flexible tubular sheath cavity volume," so that the endoscopic instrument could be pushed through the tissue cavity opening after which the total quantity of fluid inside the flexible tubular sheath cavity was increased to some volume at which the flexible tubular sheath housed on the endoscopic instrument is unable to be withdrawn totally from the tissue cavity opening 13. This volume is termed "anchoring flexible tubular sheath cavity volume." After attaining the anchoring flexible tubular sheath cavity volume, any attempt to pull out the endoscopic instrument from the tissue cavity opening 13 tends to compress the proximal flexible tubular sheath bulge 14, which leads to an increased pressure inside the proximal flexible tubular sheath bulge thus forcing some fluid from the proximal flexible tubular sheath bulge to escape into the distal flexible tubular sheath bulge, all of which culminates in an increase in the size of the distal flexible tubular sheath bulge. Thus, the dilated distal flexible tubular sheath bulge is unable to totally come out of a relatively narrow tissue cavity opening. The "anchoring flexible tubular sheath cavity volume" is greater than the "lesser flexible tubular sheath cavity volume" and smaller than the "maximum flexible tubular sheath cavity volume." It is also noted that, at the "maximum flexible tubular sheath cavity volume" or beyond a rolling motion, is not possible as an adequate indentation site cannot be established due to a permanent overall convexity of the outer flexible tubular sheath surface.

[0068] If the tissue cavity opening fits tightly at the indentation site, by tightly impinging all around the outer surface of the flexible tubular sheath at indentation site, then the fluid escaping from the proximal flexible tubular sheath bulge to the distal flexible tubular sheath bulge or vice versa could encounter considerable resistance to its flow, as a result of which the proximal flexible tubular sheath bulge and the distal flexible tubular sheath bulge could require a relatively greater time and physical effort in filling or emptying. The surgeon could thus find it uncomfortable to maneuver the endoscopic instrument in and out of the tissue cavity opening. To overcome this problem, two different methods are set forth below.

[0069] Referring to Figure 10D, a limited length of the inner surface has been deliberately represented by thick lines 17. The thick line 17 represents an area of the inner surface which can come in apposition with the indentation site. Area 17 of the inner surface can contain longitudinal elevated ridges which do not allow the inner and the outer surface of the flexible tubular sheath cavity to come in complete apposition with each other at the indentation site. This facilitates the exchange of fluid between the distal flexible tubular sheath bulge and the proximal flex-

ible tubular sheath bulge. The longitudinal ridges are preferably longitudinal thickenings along the inner surface which project into the flexible tubular sheath cavity 4. The longitudinal thickenings project towards the flexible tubular sheath cavity 4 and are not be incorporated between the inner surface of the flexible tubular sheath cavity 4 and the external surface of the endoscopic instrument 5. The width and depth of the longitudinal thickenings can be adjusted to suit the operational needs of an endoscopic procedure. Similarly, the separation between the longitudinal thickenings can also be adjusted to suit the operational needs. As the longitudinal thickenings lie over the inner aspect of the flexible tubular sheath cavity 4, they never rub against the tissue cavity opening 13.

[0070] In an exemplary embodiment, the flexible tubular sheath cavity 4 is filled with a fluid having lubricating properties. The lubricating nature of such fluid reduces the friction between the inner and the outer surfaces at the indentation site during rolling motion of the flexible tubular sheath. This not only increases the maneuverability in the to and fro direction, but also enhances the rotatory motion of the endoscopic instrument. The fluid having lubricating properties can be a physiological oily substance such as linolenic acid, linolic acid or arachidonic acid. The fluid which has lubricating properties can also be a semi physiological oily substance, such as sunflower oil or ground nut oil. The fluid which has lubricating properties can also be xylocaine jelly which is commonly used in surgical procedures. Although xylocaine jelly is extremely viscous, it can be used beneficially in certain endoscopic procedures such as endometrial resection, where extreme stability of the endoscopic instrument is required in certain maneuvers such as while resecting the intra mural part of the fallopian tubes. The cavity fluid is preferably physiological in nature because if the flexible tubular sheath cavity accidentally bursts then the fluids may come in contact with body tissues. Similarly, the cavity 4 fluid is also preferably sterile.

[0071] It is possible that the endoscopic instrument could accidentally enter abnormally deep inside the tissue cavity and, thus, accidentally perforate the tissue cavity. To avoid this serious complication, a rigid thickening similar to 11 may also be incorporated in a distal part of the inner surface of the flexible tubular sheath cavity. Such a rigid thickening would not allow the endoscopic instrument to enter into the tissue cavity beyond a predetermined depth, the mechanism for which has already been described in the preceding paragraphs. Also the exact location of such distally located rigid thickening depends upon the cavity depth.

[0072] Referring back to Figure 10D, to introduce fluid or extra fluid inside the flexible tubular sheath cavity, a separate small caliber delivery tube could be connected to the flexible tubular sheath cavity 4. A suitable site for connecting such a tube could be at a location just distal to the rigid thickening 11, so that the tube passes between the inner surface of the flexible tubular sheath and the

external surface of the endoscopic instrument to reach the location. The proximal open end of such tube could be provided with a controllable valve, which would prevent the flexible tubular sheath cavity fluid from escaping during an endoscopic procedure. A tube for introducing fluid into the flexible tubular sheath cavity is termed the "cavity filling tube" (not shown).

[0073] The surgeon could perform an entire endoscopic procedure by using a flexible tubular sheath cavity which has already been predistended to a lesser flexible tubular sheath cavity volume. Alternatively, the surgeon may initially introduce a flexible tubular sheath cavity distended to a lesser flexible tubular sheath cavity volume and later introduce extra fluid via the cavity filling tube to attain anchoring flexible tubular sheath cavity volume.

[0074] The thickness, strength and elasticity of the polymeric material constituting the flexible tubular sheath cavity may be chosen according to the operational needs of the endoscopic procedure. In relatively delicate cavities like the uterine cavity, the polymeric material could be relatively thin and elastic. In tough cavities, like the joint cavity, the polymeric material should preferably be thicker and stronger. The flexible tubular sheath cavity can contain any fluid (i.e., liquid or gas), depending on the surgeon's choice and the endoscopic procedure. Further, the fluid may have various degrees of viscosity. Certain maneuvers like resecting the intramural part of the fallopian tubes require great precision. Such maneuvers may be benefited by choosing high viscosity fluids for the flexible tubular sheath cavity. Some endoscopic instruments have multiple holes at their distal end just adjacent to the tip of the endoscopic instrument. Such holes help in extracting waste fluid during continuous flow irrigation. Preferably, the flexible tubular sheath is deployed so that these holes never get covered.

[0075] The system for managing a liquid or gas distending medium of the present invention is a hollow double walled, pressurized, cylindrical body movable by a rolling type of motion. The system of the present invention is used for minimizing and regulating the leakage of liquid or gaseous distending media by the sides of the endoscopic instrument, such that the entire maneuver also enhances the maneuverability of the endoscopic instrument.

[0076] The system greatly enhances the efficiency and patient safety in various endoscopic procedures, by minimizing or avoiding the leakage of the distending medium by the sides of the endoscopic instrument.

[0077] Although the present invention has been described in relation to particular embodiments thereof, many other variations and modifications and other uses will become apparent to those skilled in the art. Within the scope of the claims.

Claims

1. A flexible tubular sheath (1) for preventing leakage

of fluid distending media during an endoscopic procedure, comprising a double-wall structure (1) formed of an elastic, polymeric material, wherein:

5 the double-wall structure defines a cavity (4), the cavity (4) contains a fluid, the double-wall structure (1) is sized to be installed over an endoscopic instrument (5), and being configured to be introduced over at least a part of the endoscopic instrument (5) by a rolling motion and then introduced by a rolling motion into a cavity wherein the flexible tubular sheath (1) has openings at both ends, **characterised in that** the flexible tubular sheath cavity (4) is permanently filled with a predetermined amount of fluid so that when unconstrained, it retains its shape and has substantially uniform inner and outer diameters along its length between the openings.

20 2. The flexible tubular sheath of claim 1, wherein the cavity (4) is filled with a mixture of a liquid and a gas.

25 3. The flexible tubular sheath of claim 1, wherein the cavity (4) is filled with a fluid having lubricating properties.

30 4. The flexible tubular sheath of claim 1, wherein the double-wall structure (1) is formed of an elastic material.

5. The flexible tubular sheath of claim 4, wherein the elastic material is an elastic polymeric material.

35 6. The flexible tubular sheath of claim 1, wherein the flexible tubular sheath (1) is provided with a plurality of ridges.

40 7. The flexible tubular sheath of claim 1, wherein the flexible tubular sheath (1) is provided with a rigid portion (11).

8. The flexible tubular sheath of claim 7, wherein the rigid portion (11) is a metallic wire.

45 9. A system for managing a distending medium during an endoscopic procedure, comprising:

50 an endoscopic instrument (5); and a flexible tubular sheath (1) according to any preceding claim, surrounding at least part of the endoscopic instrument (5).

55 10. The system of claim 9, wherein the endoscopic instrument (5) is selected from the group consisting of endoscopes, shavers, scissors, forceps, tissue retractors, probes and electrodes.

11. A system for inserting an endoscopic instrument during an endoscopic procedure, comprising the system of claim 9, together with a flexible tubular sheath applicator, wherein the flexible tubular sheath (1) is placed over the flexible tubular sheath applicator.

Patentansprüche

1. Flexible schlauchartige Hülle (1) für das Verhindern eines Austrittes von sich ausdehnenden fluidischen Medien während eines endoskopischen Eingriffes, die eine doppelwandige Struktur (1) aufweist, die aus einem elastischen polymeren Material gebildet wird, wobei:

die doppelwandige Struktur einen Hohlraum (4) definiert;

der Hohlraum (4) ein Fluid enthält;

die doppelwandige Struktur (1) so bemessen ist, dass sie über einem endoskopischen Instrument (5) angebracht werden kann und ausgebildet ist, um über mindestens einem Teil des endoskopischen Instrumentes (5) mittels einer Rollbewegung eingeführt und danach mittels einer Rollbewegung in einen Hohlraum eingebracht zu werden, wobei

die flexible schlauchartige Hülle (1) Öffnungen an beiden Enden aufweist, **dadurch gekennzeichnet, dass**

der Hohlraum (4) der flexiblen schlauchartigen Hülle dauerhaft mit einer vorgegebenen Menge an Fluid gefüllt ist, so dass, wenn er uneingeschränkt ist, er seine Form beibehält und im Wesentlichen gleichmäßige Innen- und Außendurchmesser entlang seiner Länge zwischen den Öffnungen aufweist.

2. Flexible schlauchartige Hülle nach Anspruch 1, bei der der Hohlraum (4) mit einer Mischung aus einer Flüssigkeit und einem Gas gefüllt ist.
3. Flexible schlauchartige Hülle nach Anspruch 1, bei der der Hohlraum (4) mit einem Fluid mit Schmier-eigenschaften gefüllt ist.
4. Flexible schlauchartige Hülle nach Anspruch 1, bei der die doppelwandige Struktur (1) aus einem elastischen Material gebildet wird.
5. Flexible schlauchartige Hülle nach Anspruch 4, bei der das elastische Material ein elastisches polymeres Material ist.
6. Flexible schlauchartige Hülle nach Anspruch 1, bei der die flexible schlauchartige Hülle (1) mit einer Vielzahl von Wülsten versehen ist.

7. Flexible schlauchartige Hülle nach Anspruch 1, bei der die flexible schlauchartige Hülle (1) mit einem starren Abschnitt (11) versehen ist.

- 5 8. Flexible schlauchartige Hülle nach Anspruch 7, bei der der starre Abschnitt (11) ein Metalldraht ist.

9. System zur Handhabung eines sich ausdehnenden Mediums während eines endoskopischen Eingriffes, das aufweist:

ein endoskopisches Instrument (5); und eine flexible schlauchartige Hülle (1) nach einem der vorhergehenden Ansprüche, die mindestens einen Teil des endoskopischen Instrumentes (5) umgibt.

10. System nach Anspruch 9, bei dem das endoskopische Instrument (5) aus der Gruppe ausgewählt wird, die aus Endoskopen, Rasierern, Scheren, Zangen, Gewebewundhaken, Sonden und Elektroden besteht.

11. System für das Einsetzen eines endoskopischen Instrumentes während eines endoskopischen Eingriffes, das das System nach Anspruch 9 aufweist, zusammen mit einem Applikator für die flexible schlauchartige Hülle, wobei die flexible schlauchartige Hülle (1) über dem Applikator für die flexible schlauchartige Hülle angeordnet ist.

Revendications

1. Gaine tubulaire flexible (1) destinée à empêcher une fuite de milieux de distension de fluide au cours d'une intervention endoscopique, comprenant une structure à paroi double (1) composée d'un matériau polymère élastique, dans laquelle :

la structure à paroi double définit une cavité (4) ; la cavité (4) contient un fluide ;

la structure à paroi double (1) est dimensionnée de sorte à être installée au-dessus d'un instrument endoscopique (5), et est configurée de sorte à être introduite au-dessus d'au moins une partie de l'instrument endoscopique (5) par un mouvement de roulement, avant son introduction par un mouvement de roulement dans une cavité ; et dans laquelle

la gaine tubulaire flexible (1) comporte des ouvertures au niveau des deux extrémités, **caractérisée en ce que** la cavité de la gaine tubulaire flexible (4) est remplie en permanence d'une quantité prédéterminée de fluide, de sorte que dans l'état sans contrainte, elle maintient sa forme et a des diamètres intérieur et extérieur pratiquement uniformes le long de sa longueur

entre les ouvertures.

2. Gaine tubulaire flexible selon la revendication 1, dans laquelle la cavité (4) est remplie d'un mélange d'un liquide et d'un gaz. 5
3. Gaine tubulaire flexible selon la revendication 1, dans laquelle la cavité (4) est remplie d'un fluide présentant des propriétés lubrifiantes. 10
4. Gaine tubulaire flexible selon la revendication 1, dans laquelle la structure à paroi double (1) est composée d'un matériau élastique. 15
5. Gaine tubulaire flexible selon la revendication 4, dans laquelle le matériau élastique est un matériau polymère élastique. 20
6. Gaine tubulaire flexible selon la revendication 1, dans laquelle la gaine tubulaire flexible (1) comporte plusieurs nervures. 25
7. Gaine tubulaire flexible selon la revendication 1, dans laquelle la gaine tubulaire flexible comporte une partie rigide (11). 30
8. Gaine tubulaire flexible selon la revendication 7, dans laquelle la partie rigide (11) est constituée par un fil métallique. 35
9. Système de gestion d'un milieu de distension au cours d'une intervention endoscopique, comprenant :
 - un instrument endoscopique (5) ; et 40
 - une gaine tubulaire flexible (1) selon l'une quelconque des revendications précédentes, entourant au moins une partie de l'instrument endoscopique (5). 45
10. Système selon la revendication 9, dans lequel l'instrument endoscopique (5) est sélectionné dans le groupe constitué d'endoscopes, de rasoirs, de ciseaux, de forceps, d'écarteurs de tissus, de sondes et d'électrodes. 50
11. Système d'insertion d'un instrument endoscopique au cours d'une intervention endoscopique, comprenant le système selon la revendication 9, en combinaison avec un applicateur de la gaine tubulaire flexible, la gaine tubulaire flexible (1) étant placée au-dessus de l'applicateur de la gaine tubulaire flexible. 55

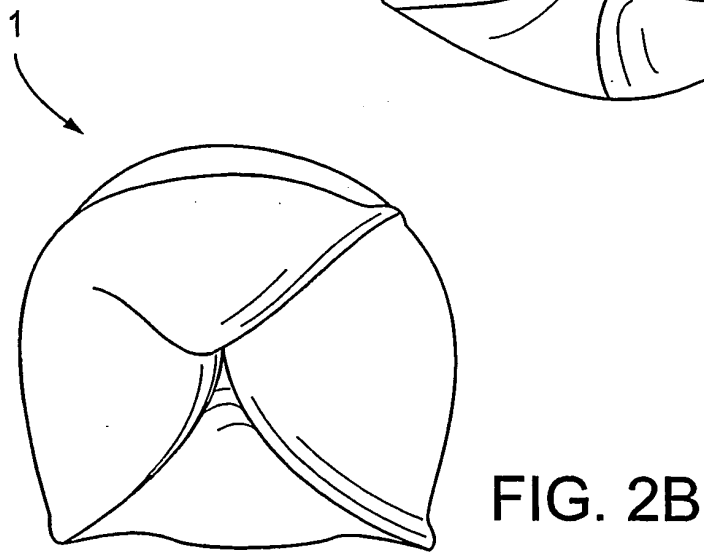
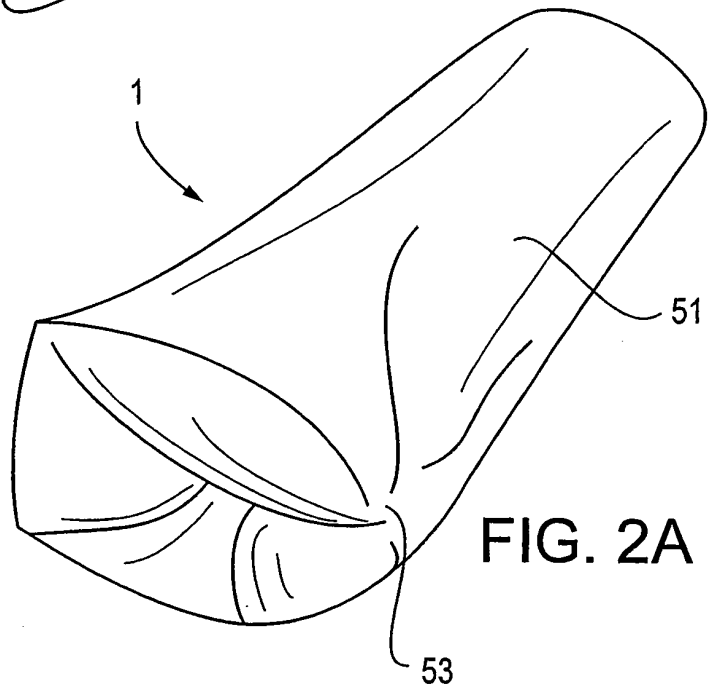
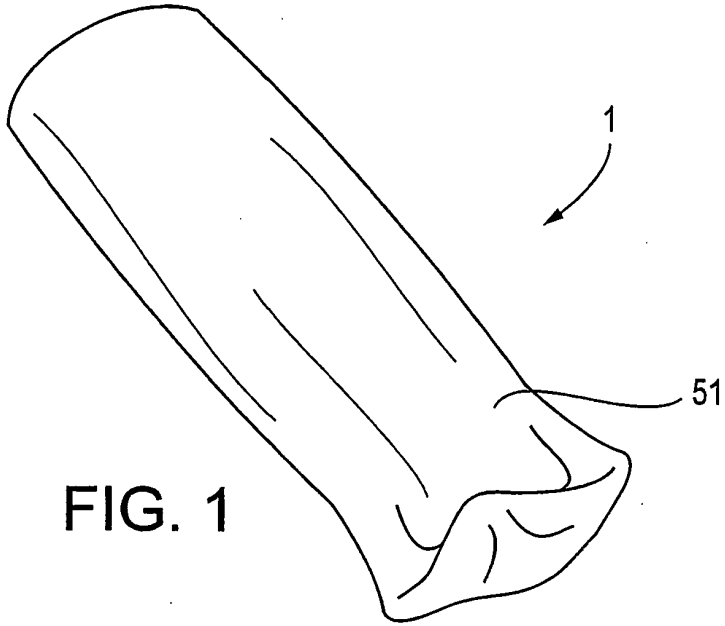

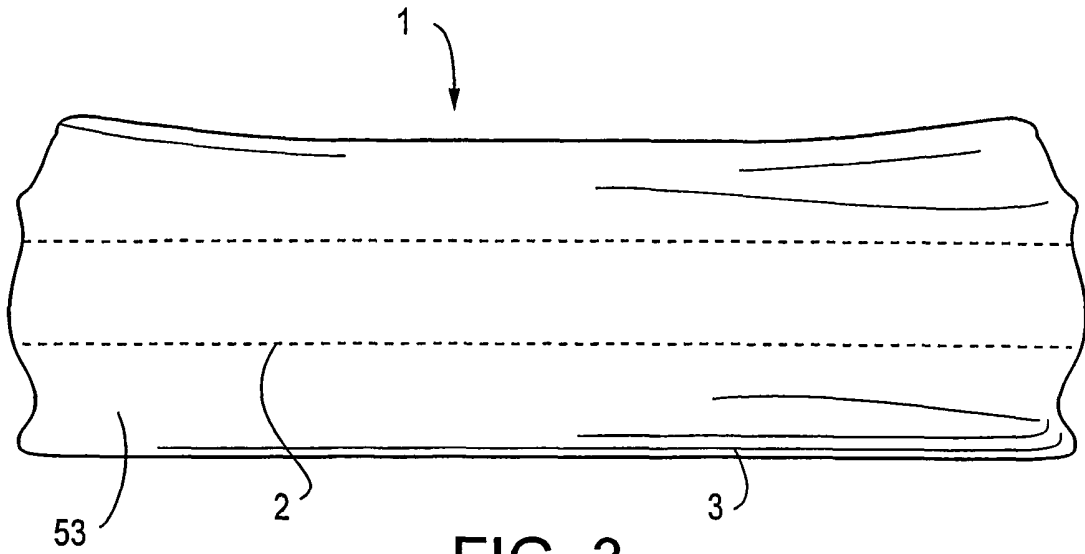

FIG. 3

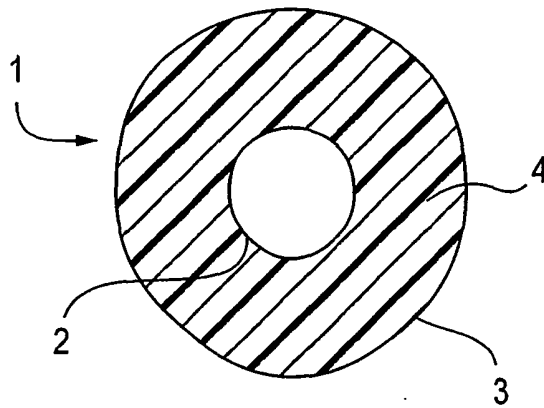

FIG. 4

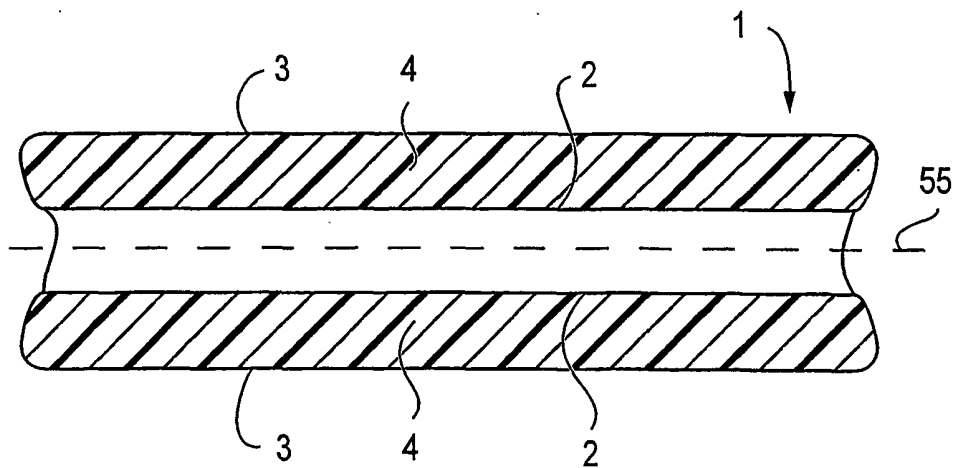

FIG. 5

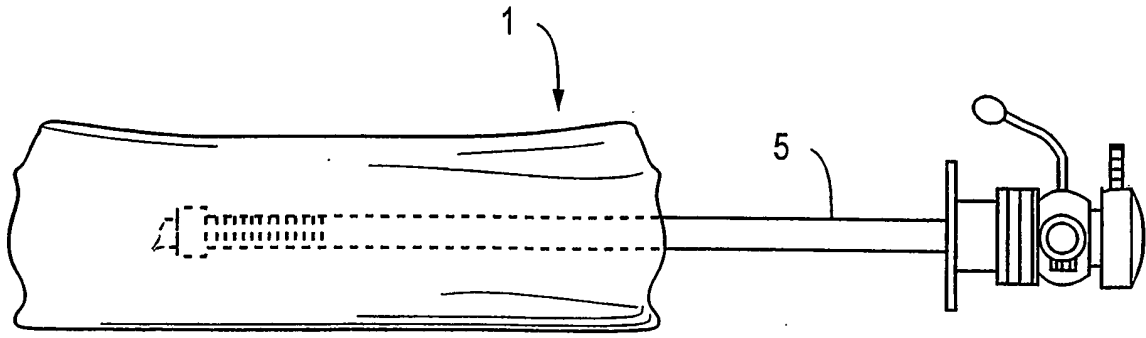

FIG. 6A

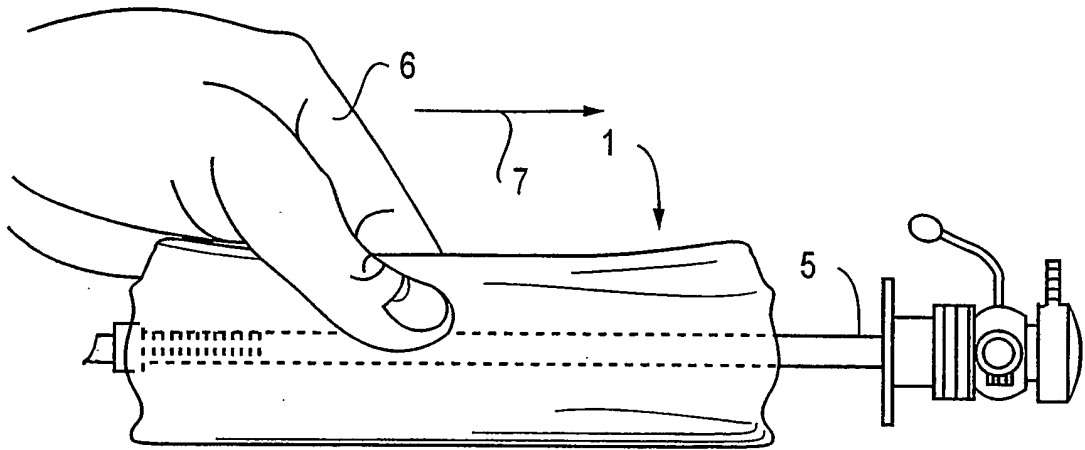

FIG. 6B

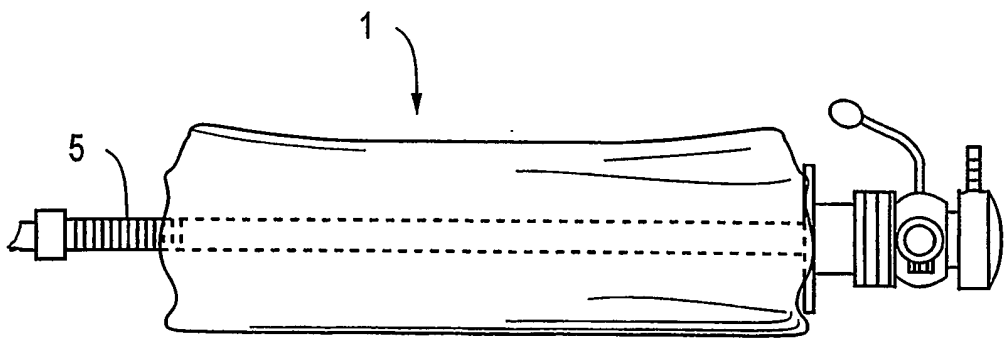

FIG. 6C

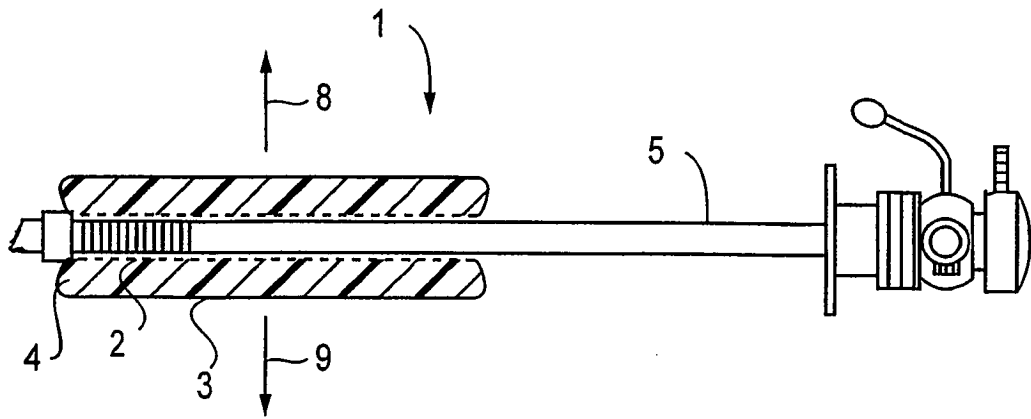

FIG. 7A

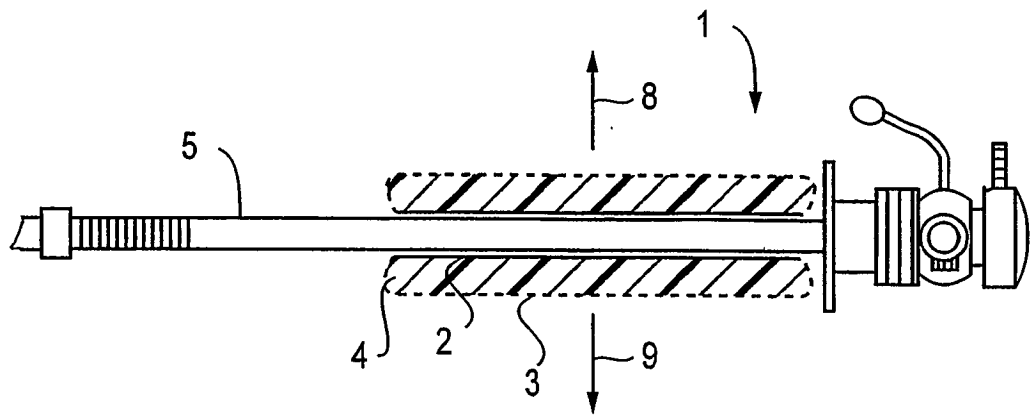

FIG. 7B

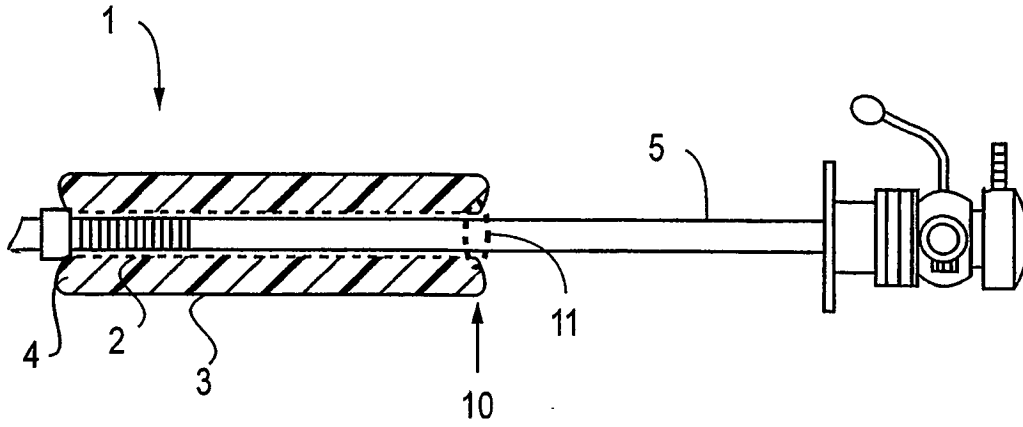

FIG. 8A

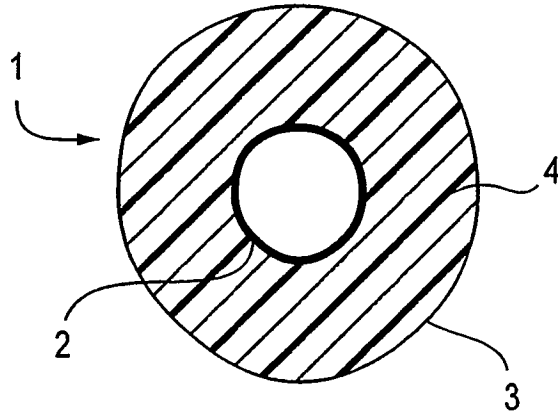

FIG. 8B

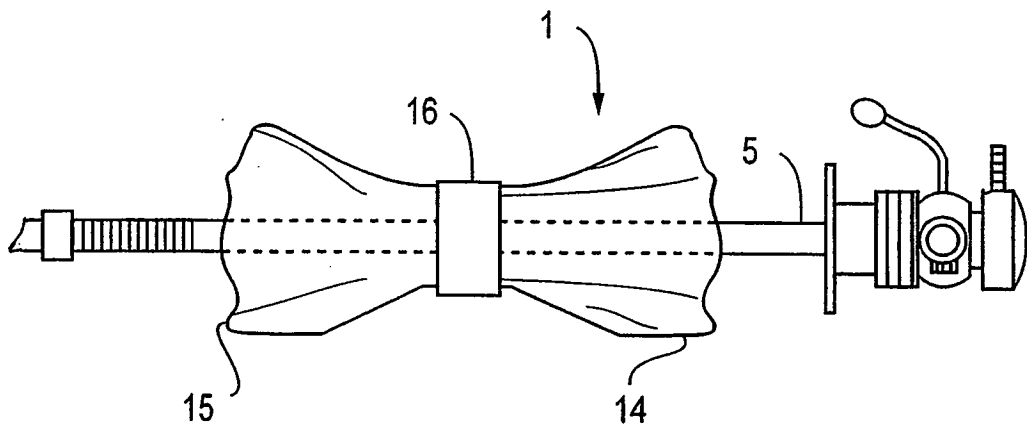

FIG. 9

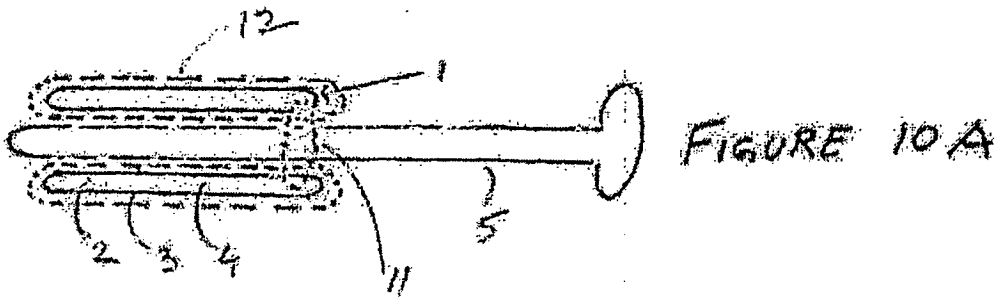

FIGURE 10A

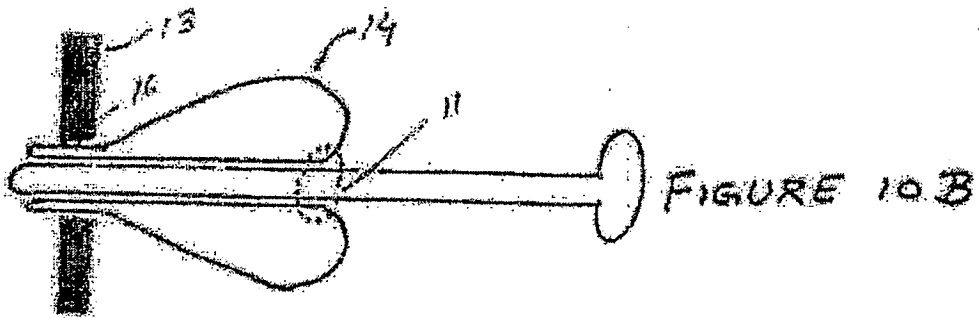

FIGURE 10B

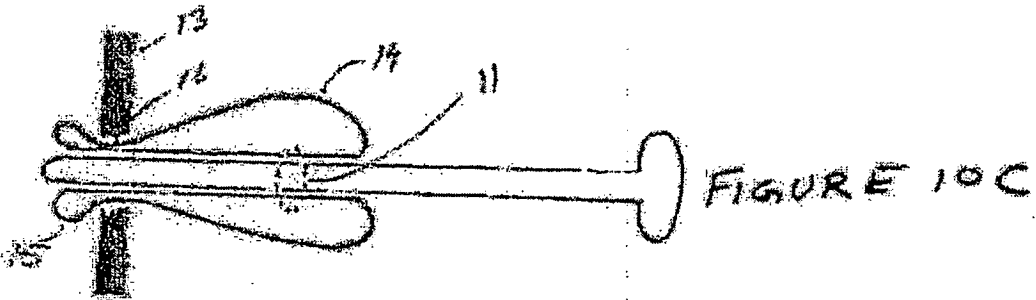

FIGURE 10C

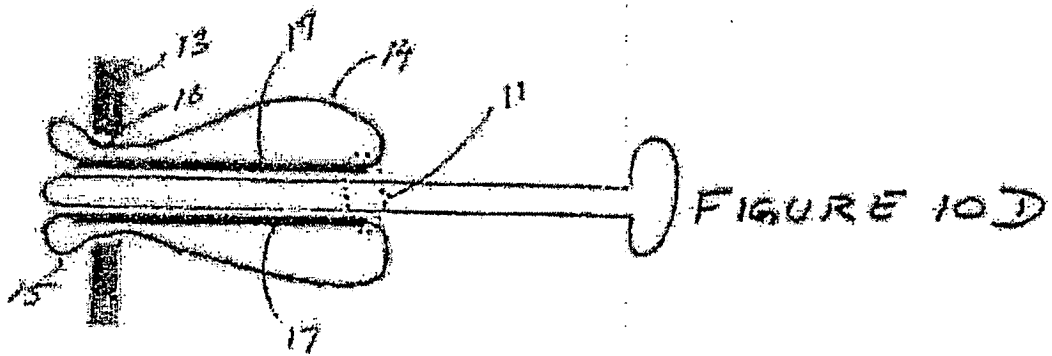

FIGURE 10D

REFERENCES CITED IN THE DESCRIPTION

This list of references cited by the applicant is for the reader's convenience only. It does not form part of the European patent document. Even though great care has been taken in compiling the references, errors or omissions cannot be excluded and the EPO disclaims all liability in this regard.

Patent documents cited in the description

- US 20040162531 A [0016]

专利名称(译)	用于在内窥镜外科手术过程中最小化扩张介质泄漏的系统		
公开(公告)号	EP1824397B1	公开(公告)日	2009-09-02
申请号	EP2005810160	申请日	2005-11-28
[标]申请(专利权)人(译)	KUMAR ATUL		
申请(专利权)人(译)	KUMAR , ATUL		
当前申请(专利权)人(译)	KUMAR , ATUL		
[标]发明人	KUMAR ALKA ANIL HOSPITAL		
发明人	KUMAR, ALKA, ANIL HOSPITAL		
IPC分类号	A61B17/34		
CPC分类号	A61B17/3423 A61B17/3421 A61B17/3431		
优先权	2392DEL2004 2004-11-30 IN		
其他公开文献	EP1824397A2		
外部链接	Espacenet		

摘要(译)

一种用于在内窥镜手术例如关节镜检查，宫腔镜检查或腹腔镜检查中最小化内窥镜器械侧面的流体扩张介质泄漏的系统。具有包含加压流体的壁的双壁柔性管状护套安装在内窥镜器械上。双壁柔性管状护套通过滚动运动进出组织空腔的自然开口或通过空腔壁中形成的切口。

