



(12) **EUROPEAN PATENT APPLICATION**

(43) Date of publication:

14.11.2001 Bulletin 2001/46

(51) Int Cl.⁷: **A61B 1/12, A61B 1/313**

(21) Application number: **00303874.2**

(22) Date of filing: **09.05.2000**

(84) Designated Contracting States:
**AT BE CH CY DE DK ES FI FR GB GR IE IT LI LU
MC NL PT SE**
Designated Extension States:
AL LT LV MK RO SI

(72) Inventors:
• **Seitzinger, Michael R.**
Greenlake, Wisconsin 54941 (US)
• **PLATTS, David**
Los Alamos, NM 87544 (US)

(71) Applicants:
• **Seitzinger, Michael R.**
Greenlake, Wisconsin 54941 (US)
• **PLATTS, David**
Los Alamos, NM 87544 (US)

(74) Representative: **Calderbank, Thomas Roger et al**
MEWBURN ELLIS
York House
23 Kingsway
London WC2B 6HP (GB)

(54) **Method for preventing laparoscope fogging**

(57) The present invention includes maintaining the region of the proximal lens (14) of a laparoscope (10) at greater than ambient temperature in order to prevent fogging during use. Heating is accomplished using commercially available chemical heat packs (12) generally used for heating boots or gloves, or by using electrically powered heating tape (18). The invention differs from

other anti-fogging devices, which either immerse the distal lens region of the laparoscope in a warm fluid or treat this lens with anti-fogging solutions, in that above-ambient temperature is continuously maintained throughout the laparoscope, since it is known that a cool laparoscope fogs when placed in the vicinity of warm, wet patient tissue.

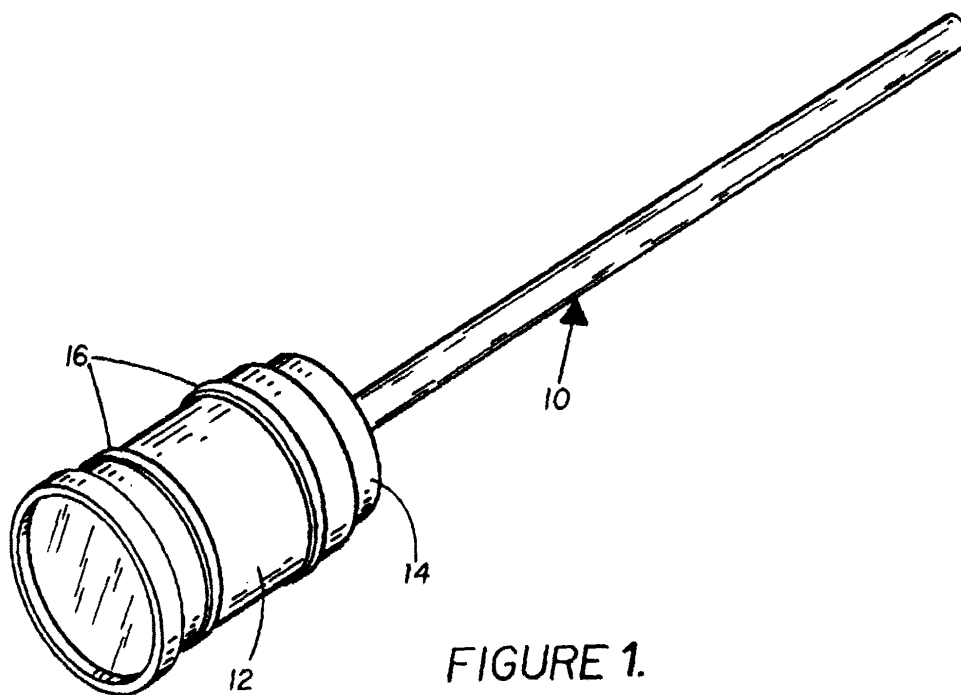

FIGURE 1.

Description

[0001] This patent application is a continuation-in-part patent application of co-pending application Serial Number 09/126,266 for "Method For Preventing Laparoscope Fogging" by Michael R. Seitzinger and David Platts which was filed on July 30, 1998.

[0002] The present invention relates generally to a method for defogging laparoscopes during surgery and, more particularly, to the use of a heat source in the region of the proximal lens for maintaining a chosen temperature difference between the laparoscope and ambient temperature.

[0003] Laparoscope fogging remains a nagging problem occurring in almost all surgical procedures, and appears to be the result of the presence of a cold lens or other optical surface in a warm, moist environment. Techniques for addressing this difficulty abound, but no one answer has emerged as the ultimate solution. Antifogging solutions that are wiped on the lens are common, but are criticized for possibly scratching the optic and for only briefly addressing the problem. Heating the laparoscope to more closely match the temperature of the body is also common, but it is thought that such procedures bake debris into the laparoscope. A variation of this latter method is achieved by rinsing the laparoscope after a cold sterilization process with warm sterile water, and taking the warmed laparoscope quickly to the field. For treating a fogged laparoscope in the field, a commercially available product known as the Laparoscopic Scope Warmer manufactured by Applied Medical Resources, includes a double-walled thermos filled with warm water and having padding inside to cushion the lens. A disposable seal is placed over the top of the device to provide insulation while permitting insertion of the laparoscope. The warm water heats the laparoscope sufficiently to clear the fogging, and has the additional feature of rising off debris. See, e.g., "Tactics Cope With Scope Fogging," in *Laparoscopic Surgery Update*, Sample Issue (1995), pages 5 and 6.

[0004] Accordingly, it is an object of the present invention to reduce fogging of laparoscopic lenses without having to apply antifogging solutions to the distal end thereof.

[0005] Another object of the present invention is to reduce fogging of laparoscopic lenses without having to remove the laparoscope from the patient for defogging during surgery.

[0006] Additional objects, advantages and novel features of the invention will be set forth in part in the description that follows, and in part will become apparent to those skilled in the art upon examination of the following or may be learned by practice of the invention. The objects and advantages of the invention may be realized and attained by means of the instrumentalities and combinations particularly pointed out in the appended claims.

[0007] To achieve the foregoing and other objects,

and in accordance with the purposes of the present invention, as embodied and broadly described herein, the method for preventing laparoscope fogging hereof includes the step of maintaining the temperature of the laparoscope in the region of the proximal lens at above ambient temperature.

[0008] Preferably, the region of the proximal lens of the laparoscope is maintained at between 35 °C and 50 °C.

[0009] It is also preferred that the step of maintaining the temperature of the laparoscope in the region of the proximal lens at above ambient temperature is achieved by wrapping a chemical or phase-change salt heat pack around the region of the proximal lens of the laparoscope.

[0010] Preferably also, the chemical heat pack is sterilized using gamma radiation.

[0011] In another aspect of the present invention in accordance with its objects and purposes, the method for preventing laparoscope fogging hereof includes the steps of maintaining a temperature of the laparoscope in a region of a proximal lens between 35 °C and 60 °C by wrapping electrical heating tape around the region of the proximal lens and directing electrical current through the heating tape such that the temperature is maintained.

[0012] Preferably, the electrical current is supplied from a battery.

[0013] Benefits and advantages of the present invention include the maintenance of an unfogged condition of the laparoscopic lenses during surgical procedures without having to remove the laparoscope from the operating field, which can significantly slow progress of the procedures, and without the need for electrical components or harsh chemical defoggers.

IN THE DRAWINGS:

[0014] The accompanying drawings, which are incorporated in and form a part of the specification, illustrates one embodiment of the present invention and, together with the description, serve to explain the principles of the invention.

[0015] FIGURE 1 is a schematic representation of a perspective view of a typical laparoscope showing the chemical heat pack wrapped around the region of the proximal lens of the laparoscope for heating both the proximal and distal lens regions of the laparoscope.

[0016] FIGURE 2 is a schematic representation of a perspective view of the laparoscope shown in FIG. 1 hereof where the heating of the proximal and distal lens regions of the laparoscope is accomplished using commercially available electrical heating tape wrapped around the region of the proximal lens of the laparoscope and powered by a battery.

[0017] Briefly, the present invention includes maintaining the region of the proximal lens of a laparoscope at greater than ambient temperature in order to avoid

fogging during use. Heating may be accomplished by using commercially available chemical heat packs generally used for heating boots or gloves, phase-change salt heat packs, or electrical heating apparatus such as electrically powered heating tape. The invention differs from other anti-fogging devices, which either immerse the distal lens region of the laparoscope in a warm fluid or treat this lens with anti-fogging solutions, in that an above-ambient temperature condition is continuously maintained throughout the laparoscope, since it is known that a cool laparoscope fogs when placed in the vicinity of warm, wet patient tissue. The proximal lens region of the laparoscope is the region of the eyepiece or a camera/lens junction of the laparoscope, depending on the type of laparoscope.

[0018] Reference will now be made in detail to the present preferred embodiments of the invention, examples of which are illustrated in the accompanying drawings. Similar or identical features are labeled with the same callouts. Turning now to Figure 1, a schematic representation of a perspective view of a commercially available laparoscope, **10**, is shown. Heating device, **12**, is attached in the region of the proximal lens end of the laparoscope, **14**, such that the heating device does not interfere with the operation of the proximal lens during use of the laparoscope. Preferably, the heating device includes commercially available chemical heat packs that commonly include iron powder, sodium chloride, vermiculite, water, and activated charcoal. The heat packs are pre-sterilized and sealed in sterile packaging. Gamma radiation has been found to be effective for sterilization, although ethylene oxide may be used. Prior to use, the heat pack is removed from the packaging, shaken to mix the contents thereof and activate the chemical reaction. The activated pack is then wrapped around the proximal end of the laparoscope and affixed thereto using fasteners, **16**. In bench tests, where heat packs were activated and wrapped around stainless steel thermometers, gamma radiation-sterilized packs were found to attain temperatures between 40 °C and 50 °C in approximately 30 min., and remain in this temperature range for about 6 h, after which the temperature was observed to decrease slowly with time. In actual surgical testing, laparoscopes heated according to the teachings of the present invention remained fogfree for several hours.

[0019] Figure 2 is a schematic representation of a perspective view of the laparoscope **10** shown in Fig. 1 hereof where the heating of the proximal and distal lens regions of the laparoscope is accomplished using commercially available electrical heating tape, **18**, wrapped around the region of the proximal lens **14** of the laparoscope, affixed thereto using fasteners **16**, and powered by battery, **20**. It was found that the region of the proximal lens achieved a temperature of approximately 60 °C in 10 min. using a "D" battery. The temperature can readily be adjusted by selecting the appropriate electrical resistance of the heating tape and the battery voltage applied to the tape. Clearly, other sources of current can

be employed to power the heating tape.

[0020] The foregoing description of the invention has been presented for purposes of illustration and description and is not intended to be exhaustive or to limit the invention to the precise form disclosed, and obviously many modifications and variations are possible in light of the above teaching. The embodiments were chosen and described in order to best explain the principles of the invention and its practical application to thereby enable others skilled in the art to best utilize the invention in various embodiments and with various modifications as are suited to the particular use contemplated. It is intended that the scope of the invention be defined by the claims appended hereto.

Claims

1. A method for preventing laparoscope fogging, which comprises the step of maintaining a temperature of the laparoscope in a region of a proximal lens between 35 °C and 50 °C by wrapping a chemical heat pack around the region of the proximal lens of said laparoscope.
2. The method for preventing laparoscope fogging as described in claim 1, wherein the chemical heat pack comprises iron powder, sodium chloride, vermiculite, water, and activated charcoal.
3. The method for preventing laparoscope fogging as described in claim 1, wherein the chemical heat pack is sterilized using gamma radiation.
4. A method for preventing laparoscope fogging, which comprises the steps of maintaining a temperature of the laparoscope in a region of a proximal lens between 35 °C and 60 °C by wrapping electrical heating tape around the region of the proximal lens and directing electrical current through the heating tape such that the temperature is maintained.
5. The method for preventing laparoscope fogging as described in claim 4, wherein the electrical current is supplied from a battery.

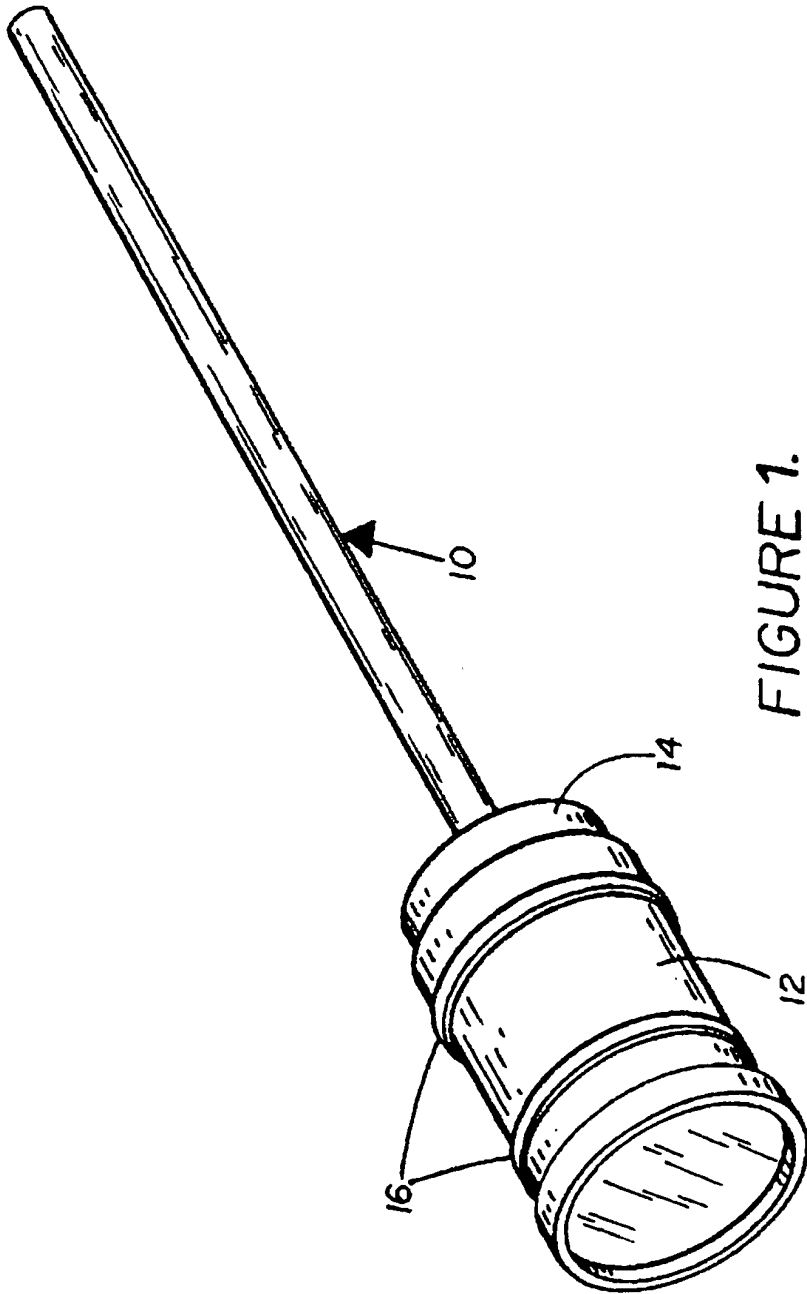

FIGURE 1.

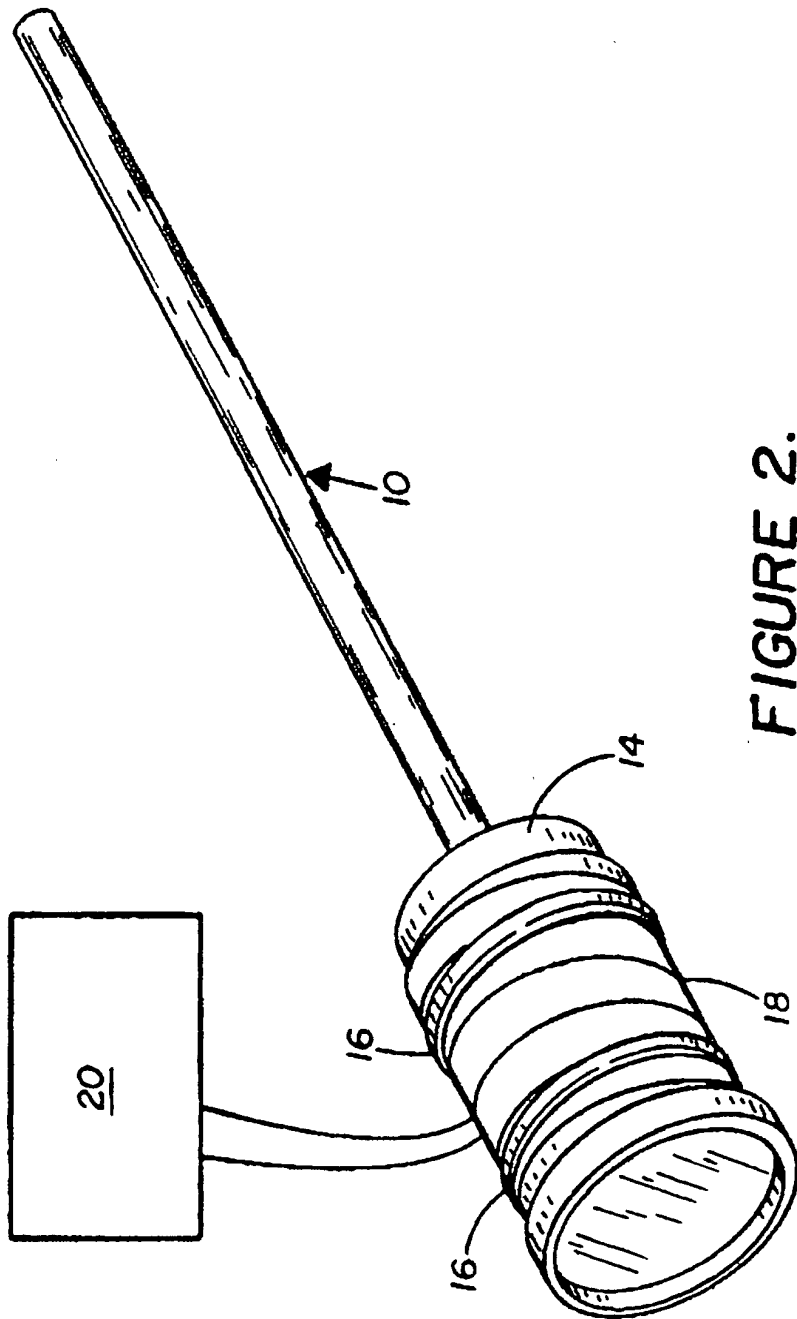

FIGURE 2.



European Patent Office

EUROPEAN SEARCH REPORT

Application Number
EP 00 30 3874

DOCUMENTS CONSIDERED TO BE RELEVANT			
Category	Citation of document with indication, where appropriate, of relevant passages	Relevant to claim	CLASSIFICATION OF THE APPLICATION (Int.Cl.7)
X	US 5 351 675 A (D. L. BRODSKY) 4 October 1994 (1994-10-04)	1	A61B1/12 A61B1/313
A	* column 1, line 26 - column 2, line 54 *	2,3	
Y	US 4 722 000 A (D. CHATENEVER) 26 January 1988 (1988-01-26) * page 1, line 12 - line 20 * * column 4, line 4 - line 65 *	4,5	
Y	US 5 605 532 A (R. SCHERMERHORN) 25 February 1997 (1997-02-25) * column 2, line 31 - line 67 * * column 3, line 52 - column 4, line 28 *	4,5	
A	US 4 076 018 A (H. HECKELE) 28 February 1978 (1978-02-28) * column 1, line 60 - column 2, line 16 * * column 4, line 5 - line 29 *	4,5	
A	WO 98 41137 A (PARKER MEDICAL LIMITED PARTNERSHIP) 24 September 1998 (1998-09-24) * page 5, line 6 - line 13 * * page 9, line 10 - page 11, line 4 *	4,5	TECHNICAL FIELDS SEARCHED (Int.Cl.7) A61B
A	DE 196 37 963 A (MGB MEDIZINISCHE GERÄTE GMBH) 19 March 1998 (1998-03-19) * column 2, line 38 - column 3, line 21 *	4,5	
The present search report has been drawn up for all claims			
Place of search THE HAGUE		Date of completion of the search 27 September 2000	Examiner Geffen, N
CATEGORY OF CITED DOCUMENTS		T : theory or principle underlying the invention E : earlier patent document, but published on, or after the filing date D : document cited in the application L : document cited for other reasons & : member of the same patent family, corresponding document	
X : particularly relevant if taken alone Y : particularly relevant if combined with another document of the same category A : technological background O : non-written disclosure P : intermediate document			

EPO FORM 1503 03.82 (P04/C01)

**ANNEX TO THE EUROPEAN SEARCH REPORT
ON EUROPEAN PATENT APPLICATION NO.**

EP 00 30 3874

This annex lists the patent family members relating to the patent documents cited in the above-mentioned European search report. The members are as contained in the European Patent Office EDP file on
The European Patent Office is in no way liable for these particulars which are merely given for the purpose of information.

27-09-2000

Patent document cited in search report	Publication date	Patent family member(s)	Publication date
US 5351675 A	04-10-1994	NONE	
US 4722000 A	26-01-1988	NONE	
US 5605532 A	25-02-1997	CA 2206862 A EP 0798980 A JP 10511298 T WO 9714349 A	24-04-1997 08-10-1997 04-11-1998 24-04-1997
US 4076018 A	28-02-1978	FR 2293180 A GB 1526069 A	02-07-1976 27-09-1978
WO 9841137 A	24-09-1998	US 5845634 A AU 6550498 A	08-12-1998 12-10-1998
DE 19637963 A	19-03-1998	WO 9811817 A WO 9806318 A EP 0926978 A EP 0920276 A	26-03-1998 19-02-1998 07-07-1999 09-06-1999

专利名称(译)	防止腹腔镜雾化的方法		
公开(公告)号	EP1153567A1	公开(公告)日	2001-11-14
申请号	EP2000303874	申请日	2000-05-09
[标]申请(专利权)人(译)	SEITZINGER迈克尔 - [R] 普氏DAVID		
申请(专利权)人(译)	SEITZINGER, MICHAEL R. 普氏, DAVID		
当前申请(专利权)人(译)	创新手术技术, INC.		
[标]发明人	SEITZINGER MICHAEL R PLATTS DAVID		
发明人	SEITZINGER, MICHAEL R. PLATTS, DAVID		
IPC分类号	A61B1/00 A61B1/12 A61B1/313 A61B17/34 A61B19/00 A61L2/04 A61L2/08 A61L2/16 G02B23/24 G02B27/00		
CPC分类号	A61B1/127 A61B1/313 A61B1/3132 G02B23/2476 G02B27/0006		
优先权	09/126266 1998-07-30 US 2307434 2000-05-03 CA 2000124275 2000-04-25 JP		
其他公开文献	EP1153567B1		
外部链接	Espacenet		

摘要(译)

本发明包括将腹腔镜 (10) 的近端镜片 (14) 的区域保持在高于环境温度，以防止在使用期间起雾。使用通常用于加热靴子或手套的市售化学热包 (12) 或通过使用电动加热带 (18) 来完成加热。本发明不同于其他防雾装置，其将腹腔镜的远侧镜片区域浸入温热的液体中或用防雾溶液处理该镜片，因为在整个腹腔镜中持续保持高于环境温度，因为它是已知凉爽的腹腔镜放置在温暖湿润的患者组织附近时会起雾。

