

(19)
(12)

(KR)
(A)

(51) 。 Int. Cl. ⁷
A61B 8/00

(11)
(43)

2001 - 0113215
2001 12 28

(21) 10 - 2000 - 0033417
(22) 2000 06 17

(71)

114

(72)

6 - 3 105 1403

5가 25 - 205

(74)

:

(54)

가

(spread spectrum signal)

1

2

3a

3b

3c 가

3d

4a

4b

5

6a 가

6b 가 2

7a 2

7b 7a

7c 7a 2

< >

1 :

11, 12 :

13 :

21 :

31 :

33 :

35 :

37 :

(spread spectrum)

가

가 가

가

가

가

가

가

가

가

(Sign

(pulse compress

가

al to Noise Ratio)
ion method)

(transducer)

가

가

(con

volution)

가

(correlator)

가

가

가

가

(FM)

가

- 13 dB

- 50dB

가

가

(spread spectrum signal)

(spread spectrum signal)

가

1 (11) (bipolar pulse)
(transducer)(1)가 (+80, -80)

(TX focus delay memory)(14) (1)
(1) 가 (11) 가

(synthetic aperture)

(21) (11) (diplexer)
가 가

(1) 가 128 가
(aperture) 64

(31) (Pre - Amplifier), 가
TGC(Time Gain Compression,) ADC(analog - digital converter, -
)

(37) (36)

(41) (envelope detection), (log compression) B -

(42) B -

2 가 (weighted chirp signal) 가
(beamforming) RF(radio frequency) 가
(near field) 가 (sidelobe) (mainlobe)

2 (12) (13) (1)
(12) (14) (13)
(14) (12) 1

2 (13) (14)가

가 (12)
(21) 1 (12) (31)

(31) RF (31) 가
(35)가

(31) RF (32) 가 RF (33)
(34)

34) 가 , 가 2 가 (

(34) (15) (31)
(34)

(15) (16)
(16)

(34) (15) RF (32) (31)
(correlation, 2)

(34), (37), (41), (42) 1

가 (FM)
가
가 = $\omega_0 + \mu t$ 가

1

$$s(t) = A w_1(t) e^{j[\omega_0 t + \frac{\mu}{2} t^2]}$$

A, ω_0 , μ , T
, $w_1(t)$

$w_1(t)$ 가 $w_1(t) = \text{rect}(t/T)$
- 13 dB - 50 dB
가

FIR(Finite Impulse Response) (window)
가 (34) 가
(weighted chirp signal) 1 $w_1(t) = \text{rect}(t/T)$

3a (blackman), 3b (rectangular) (hamming), (hanning)

3c 가 가 3b 3c L (11)가
(12)가

가 2 가 $w_1(t)$
 $w_2(t)$

2

$$y(t) = A^2 e^{j(\omega_0 t + \frac{\pi}{2} t^2)} \int_{-\infty}^{\infty} w_1(t-\xi) w_2(\xi) e^{j\mu \xi} d\xi$$

2

FIR

3d

가

3d

1

, 2

, 3

4

가

가

(1)

가

가

(TPE: Transmit Power Efficiency)

가

가

가

가

(34)

(34)

가

가

가

가

가

4a

가

가

가

(34)

가

가

4b

가

가

가

4b

2

가

5

(34)

가

가가

가 512 8 51
 $512 \times 8 = 4096$
 (MSE: mean square error), (M
 inimax: minimum local maximum) 가 MS
 E

3

$$MSE = \frac{1}{2N-1} \sum_{i=0}^{2N-2} [R_{mm}(i) - R_{md}(i)]^2$$

$R_{mm}(i)$, $R_{md}(i)$
 .N

5 (34)

101 가

102 3 MSE

103 MSE가 가

104 MSE가 가 (34)

105 MSE가 가 105 ()
 () 102 가

가 ² (34) 가

가

가 (12)가 (13) 가 RF (33) (34) 가

, 가 가 (12)

6a 7c 가 가 5MHz, 가 40MHz 0.6 3dB가
 8
 6a 7c L

2.

1 , 1 (chirp) (window)
가

3.

2 , (Hanning), (Hamming), (Blackman)

4.

1 ,

5.

4 , 1 2 (window)
가 ,

2 ,

2

6.

5 , 2 2

7.

1 , 1

8.

1 ,

9.

(spread spectrum signal)

2

10.

가

11.

10 ,

가

12.

10 ,

13.

10 , .

14.

10 , .

15.

10 , ,

2 , , ,

가 .

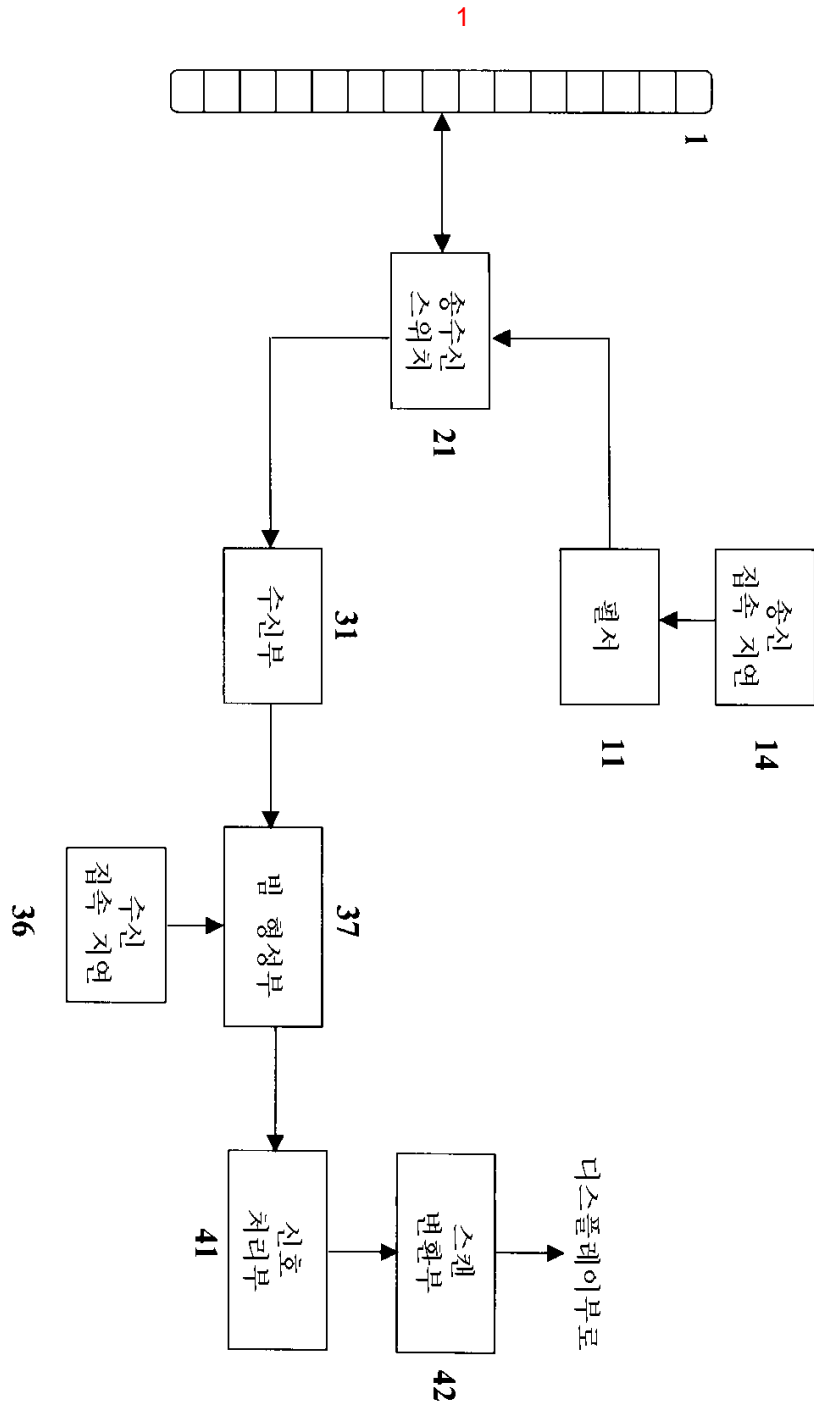

3a

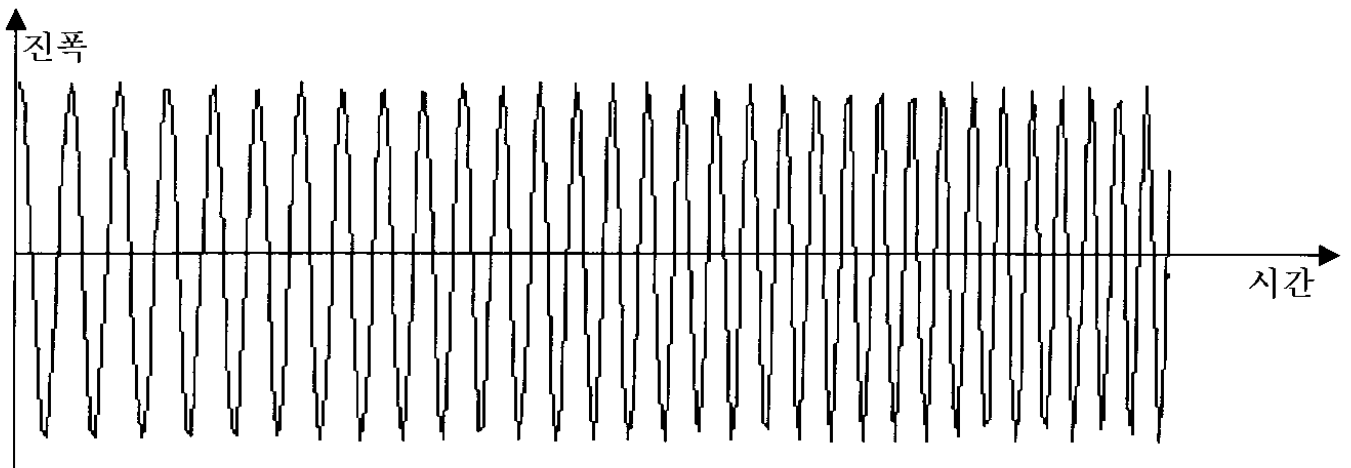

3b

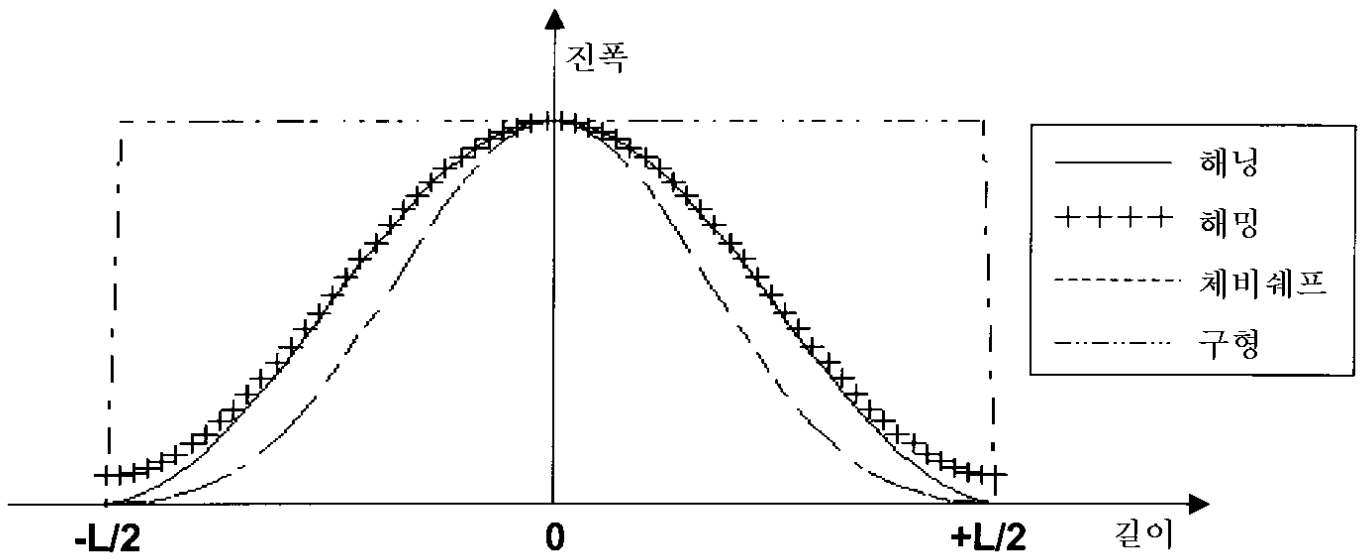

3c

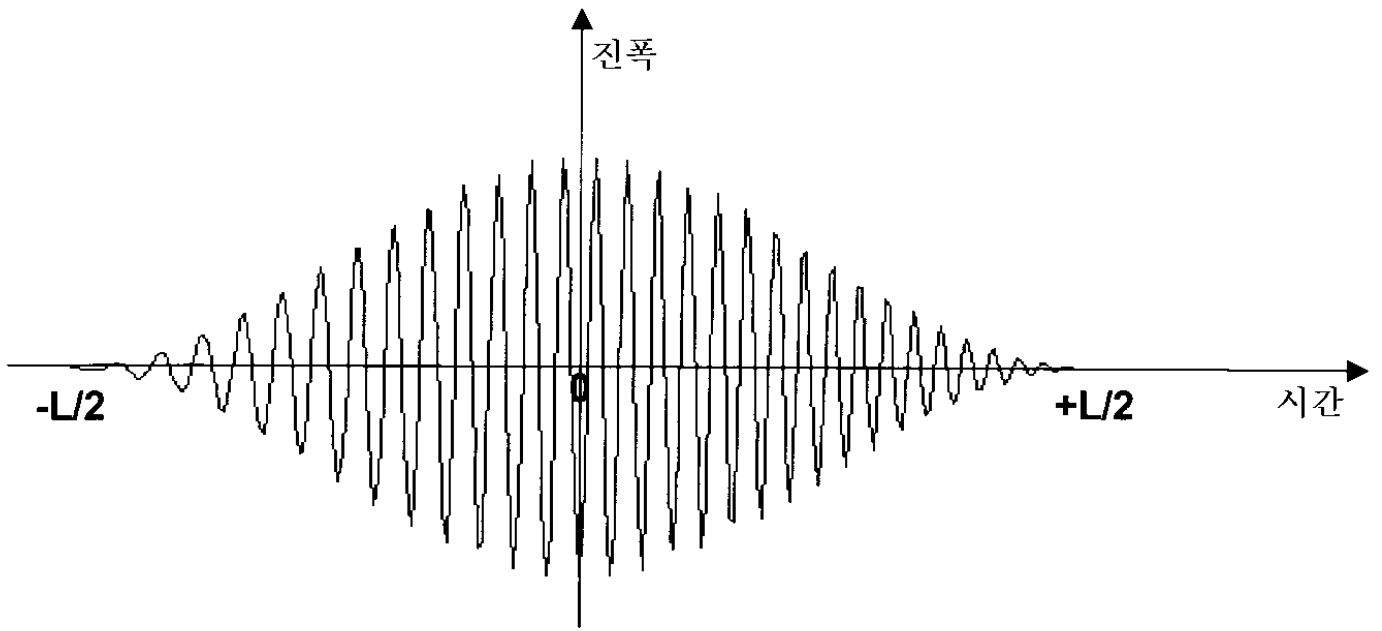

4a

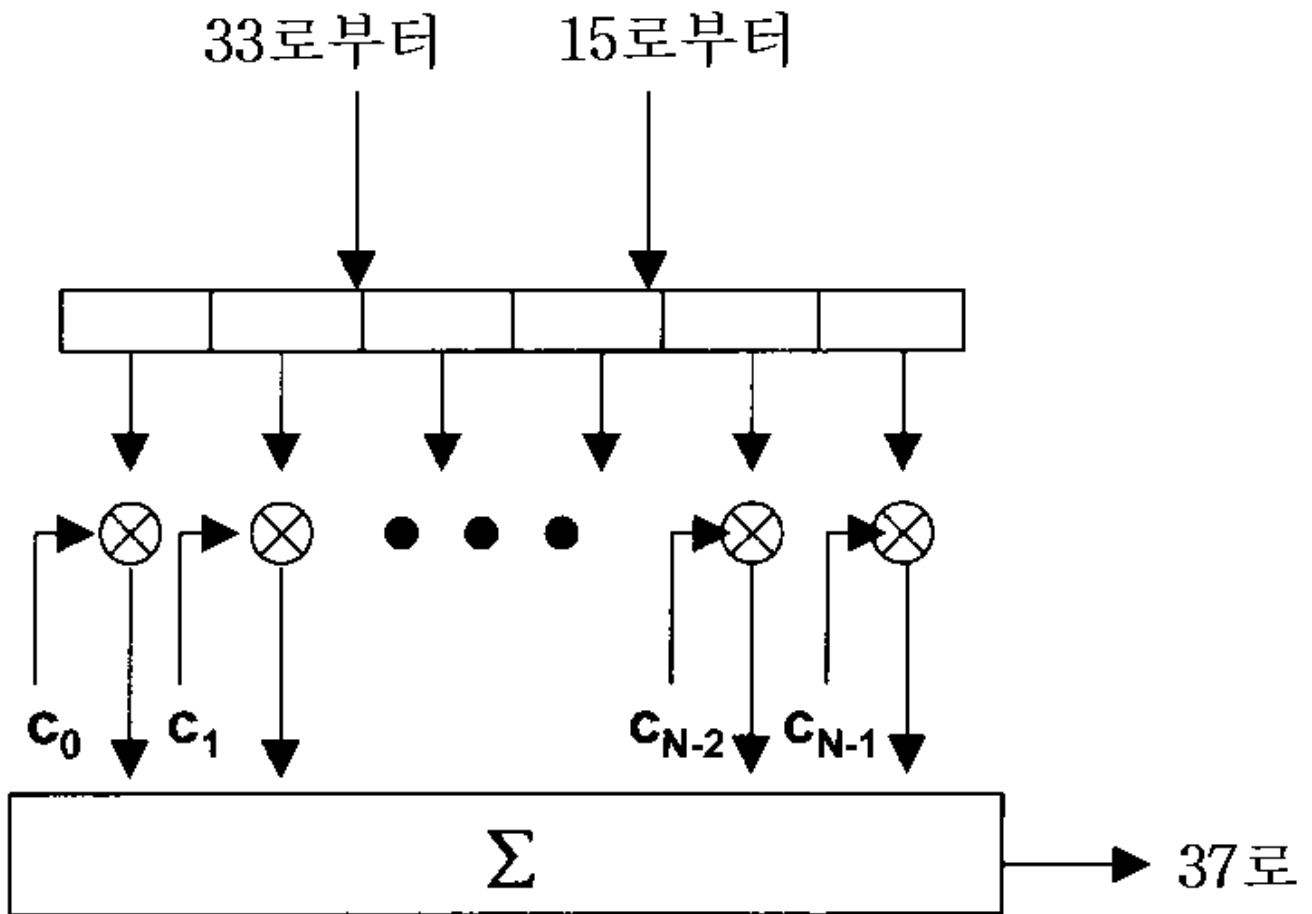

4b

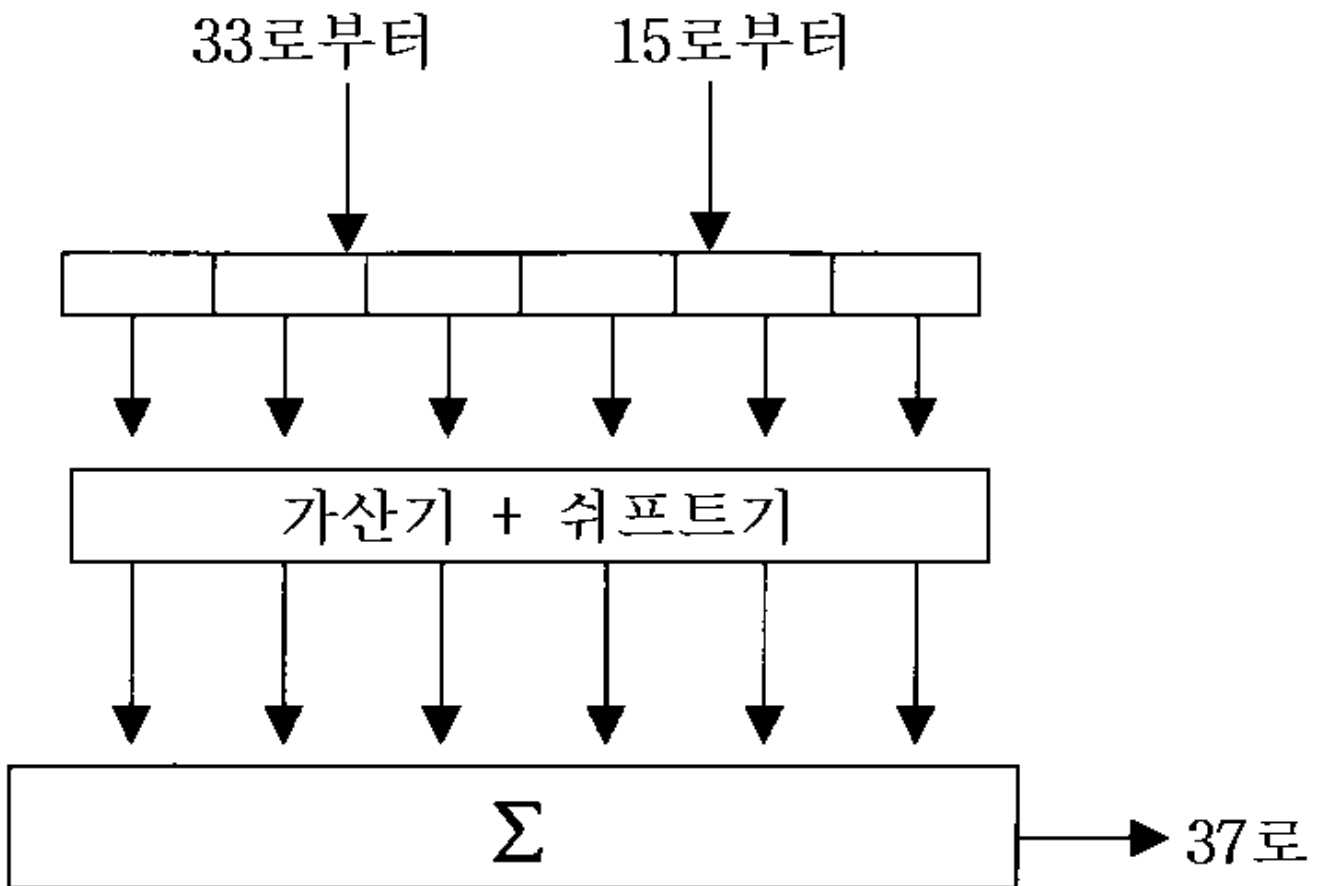

5

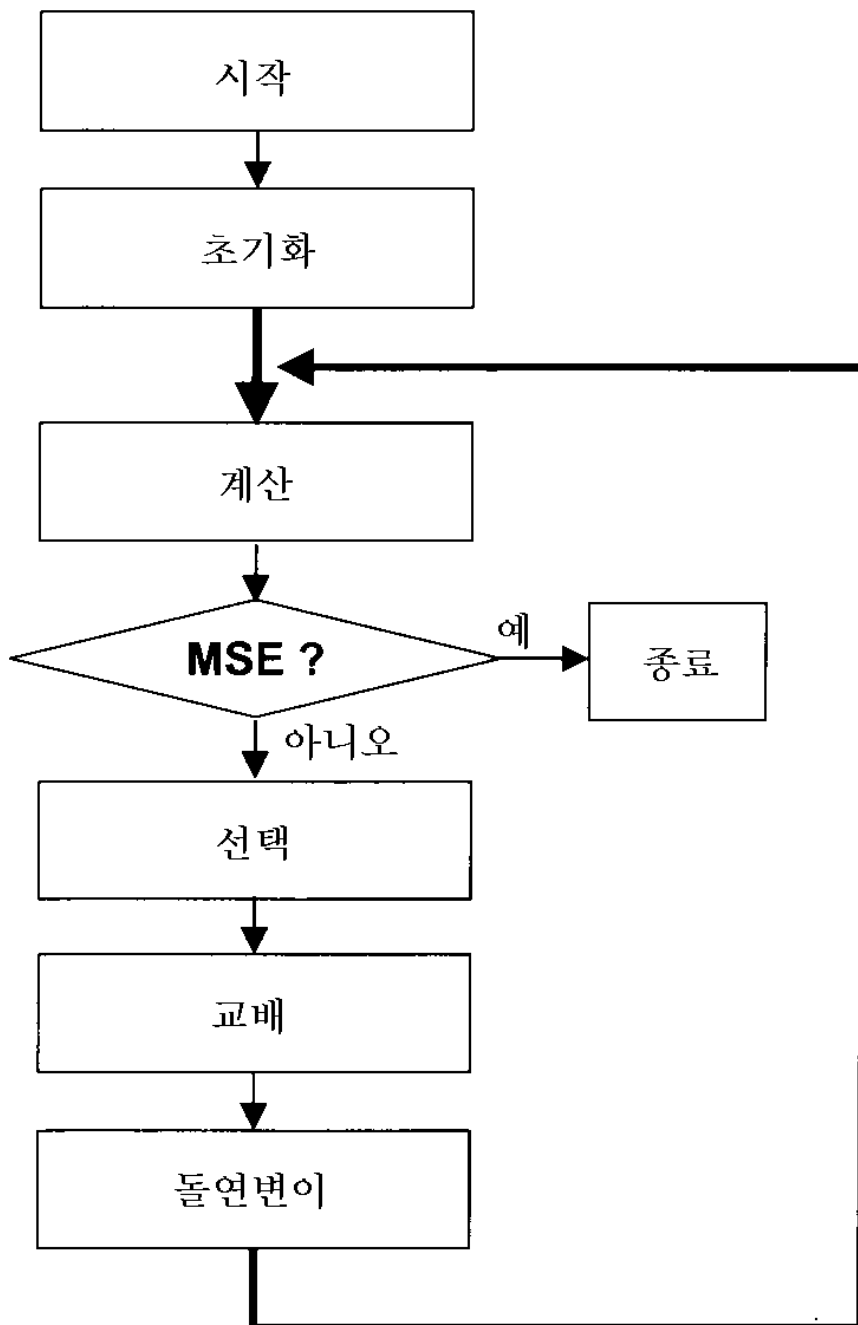

6a

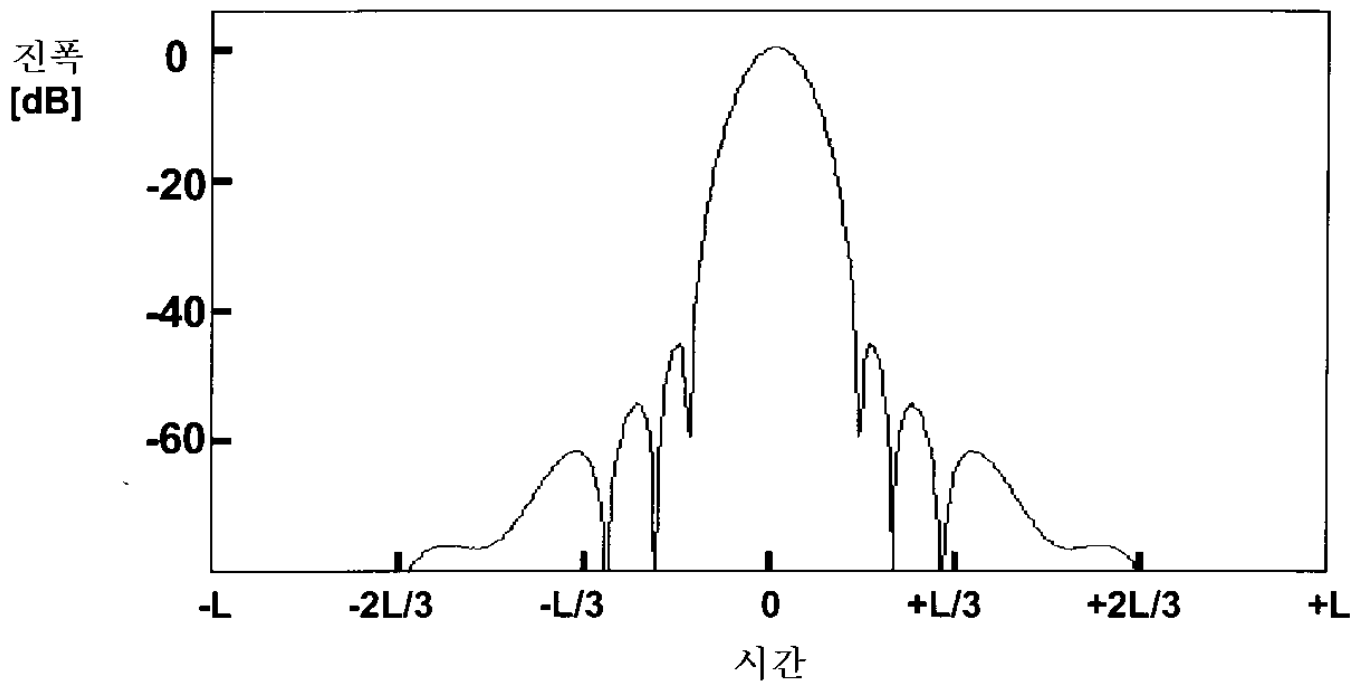

6b

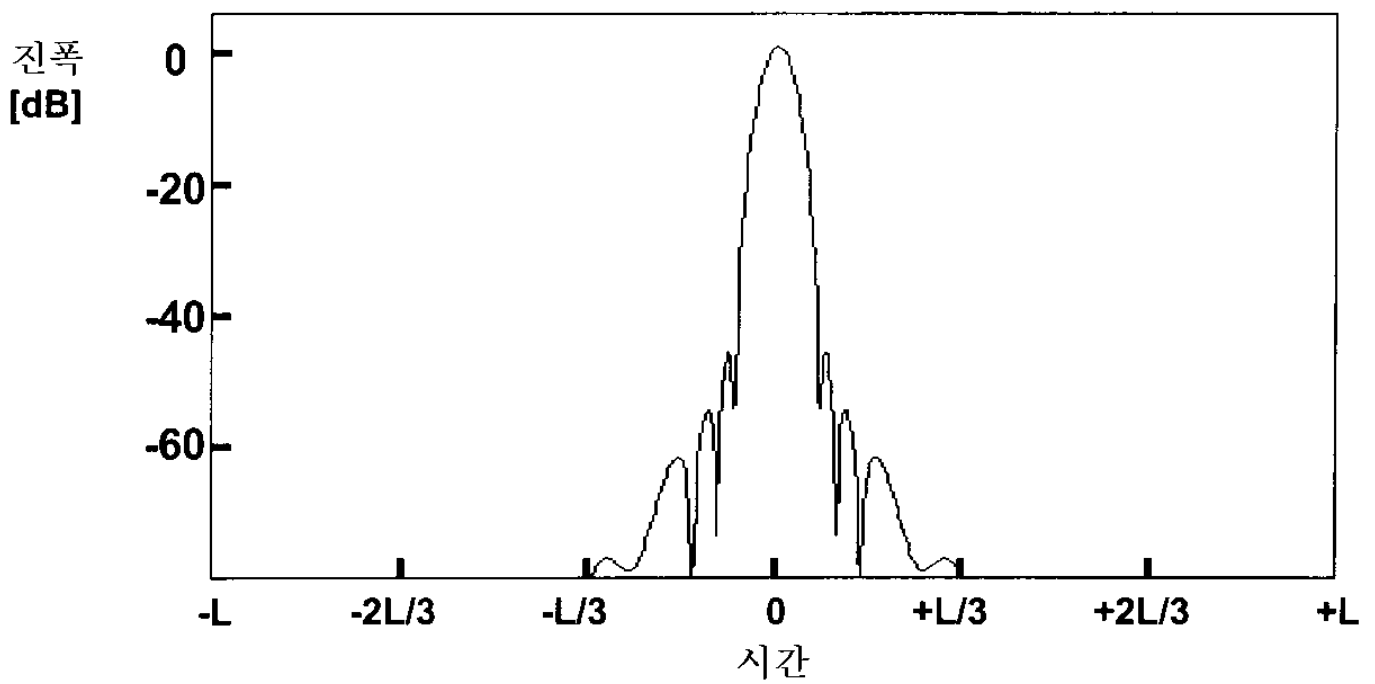

7a

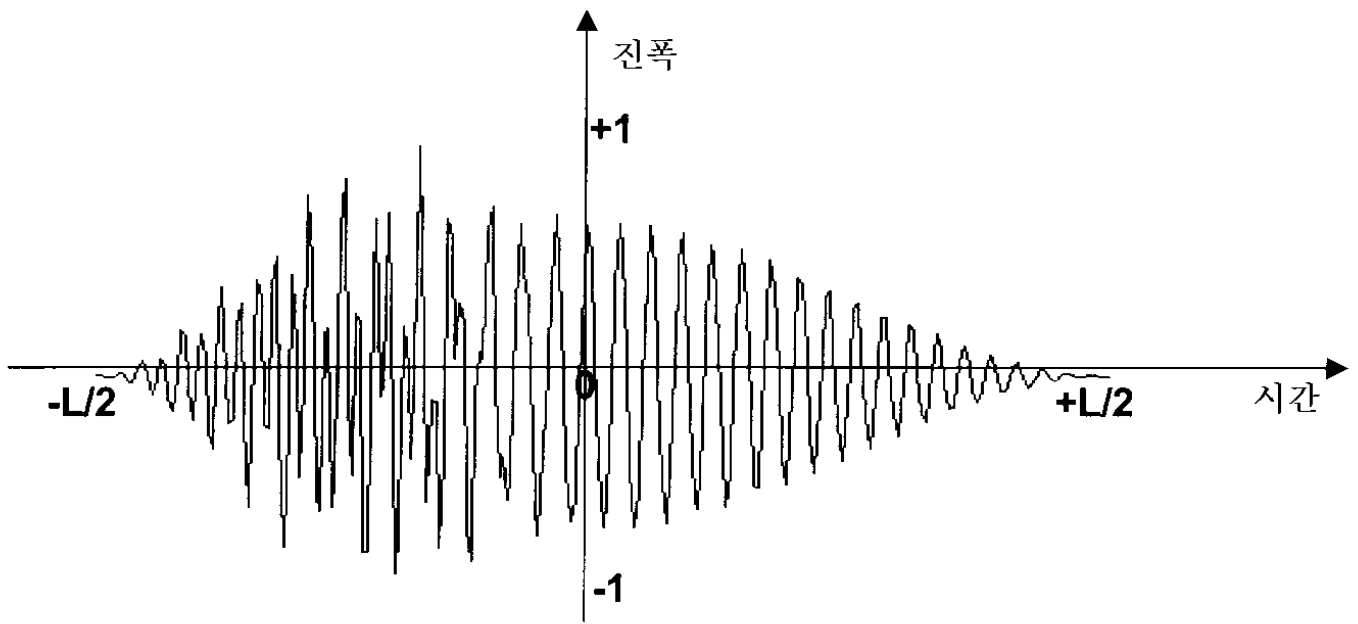

7b

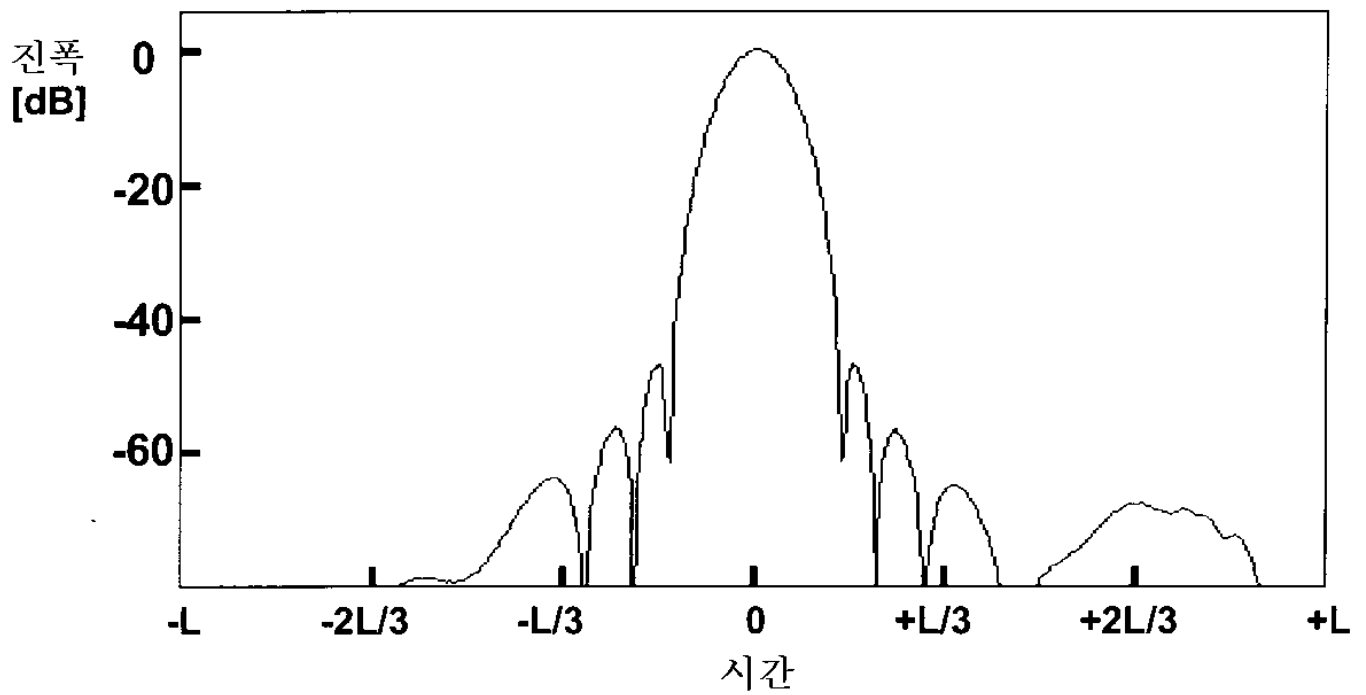

7c

