



US 20170050217A1

(19) **United States**

(12) **Patent Application Publication**  
**JOHNSON et al.**

(10) **Pub. No.: US 2017/0050217 A1**  
(43) **Pub. Date: Feb. 23, 2017**

(54) **ULTRASONIC TRANSDUCER DEVICE WITH THROUGH-SUBSTRATE VIA**

(52) **U.S. Cl.**  
CPC ..... *B06B 1/0292* (2013.01); *H02N 1/002* (2013.01); *A61B 8/4483* (2013.01); *B06B 2201/76* (2013.01)

(71) Applicant: **Texas Instruments Incorporated,**  
Dallas, TX (US)

(72) Inventors: **PETER B. JOHNSON, SUNNYVALE, CA (US); IRA OAKTREE WYGANT, PALO ALTO, CA (US)**

(57) **ABSTRACT**

A Capacitive Micromachined Ultrasonic Transducer (CMUT) device includes at least one CMUT cell including a first substrate having a top side including a patterned dielectric layer thereon including a thick and a thin dielectric region. A membrane layer is bonded on the thick dielectric region and over the thin dielectric region to provide a movable membrane over a micro-electro-mechanical system (MEMS) cavity. A through-substrate via (TSV) includes a dielectric liner which extends from a bottom side of the first substrate to a top surface of the membrane layer. A top side metal layer includes a first portion over the TSV, over the movable membrane, and coupling the TSV to the movable membrane. A patterned metal layer is on the bottom side surface of the first substrate including a first patterned layer portion contacting the bottom side of the first substrate lateral to the TSV.

(21) Appl. No.: **15/345,741**

(22) Filed: **Nov. 8, 2016**

**Related U.S. Application Data**

(63) Continuation of application No. 13/779,376, filed on Feb. 27, 2013, now Pat. No. 9,520,811.

**Publication Classification**

(51) **Int. Cl.**  
*B06B 1/02* (2006.01)  
*A61B 8/00* (2006.01)  
*H02N 1/00* (2006.01)

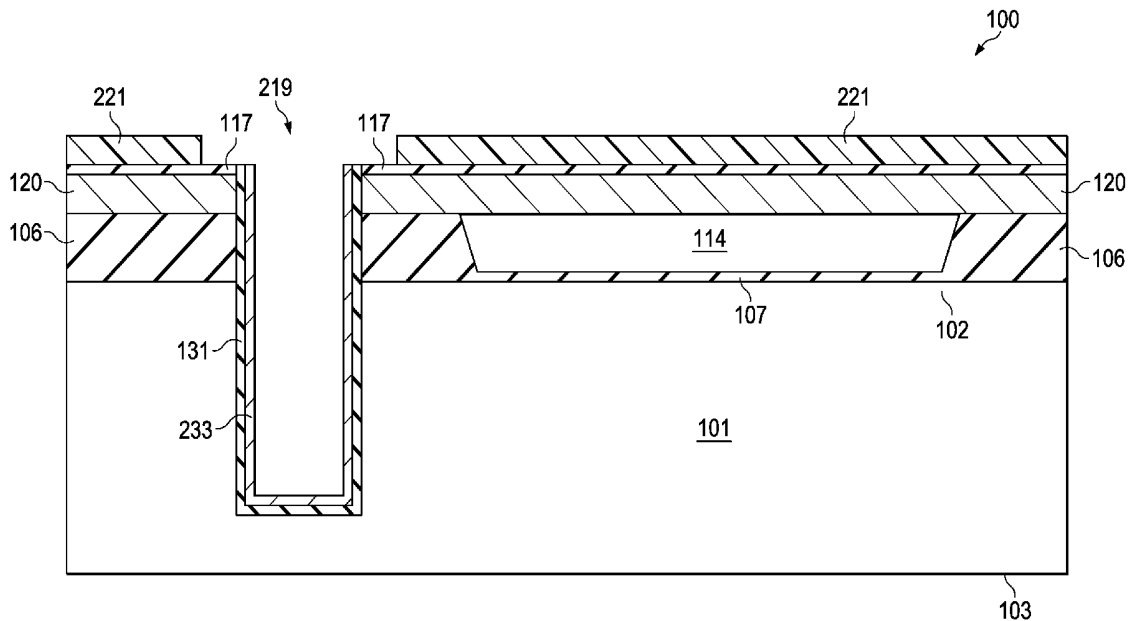

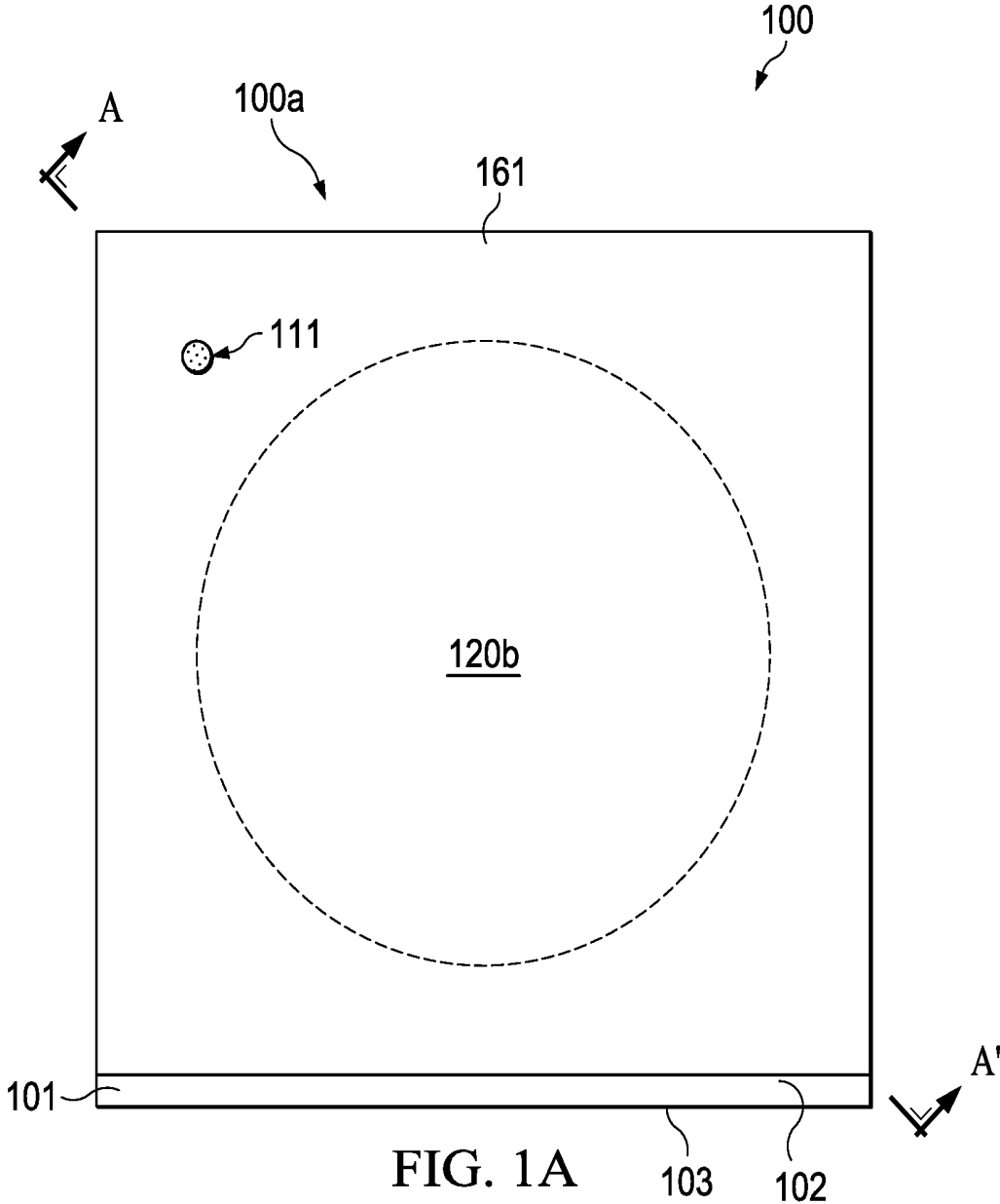

FIG. 1A

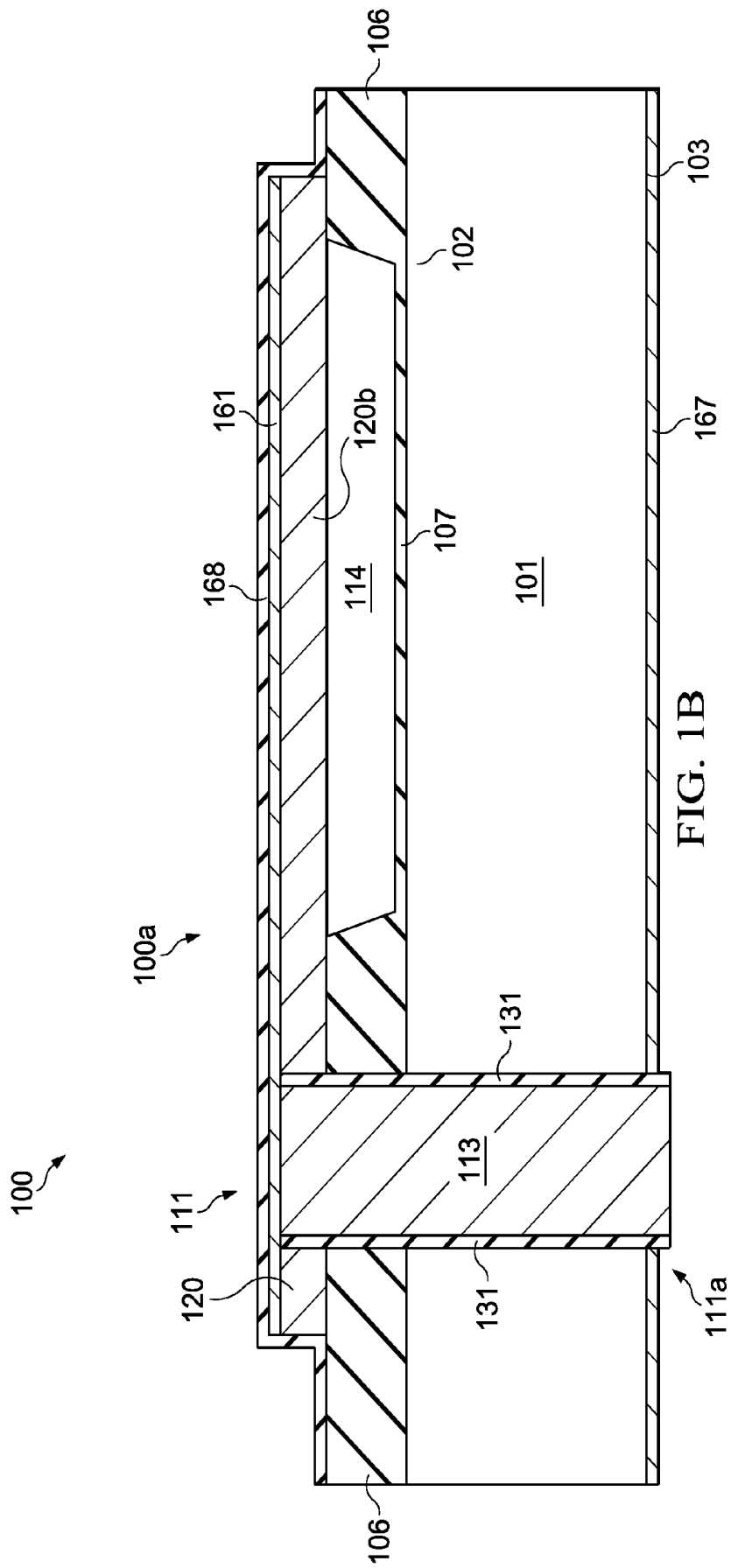

FIG. 1B

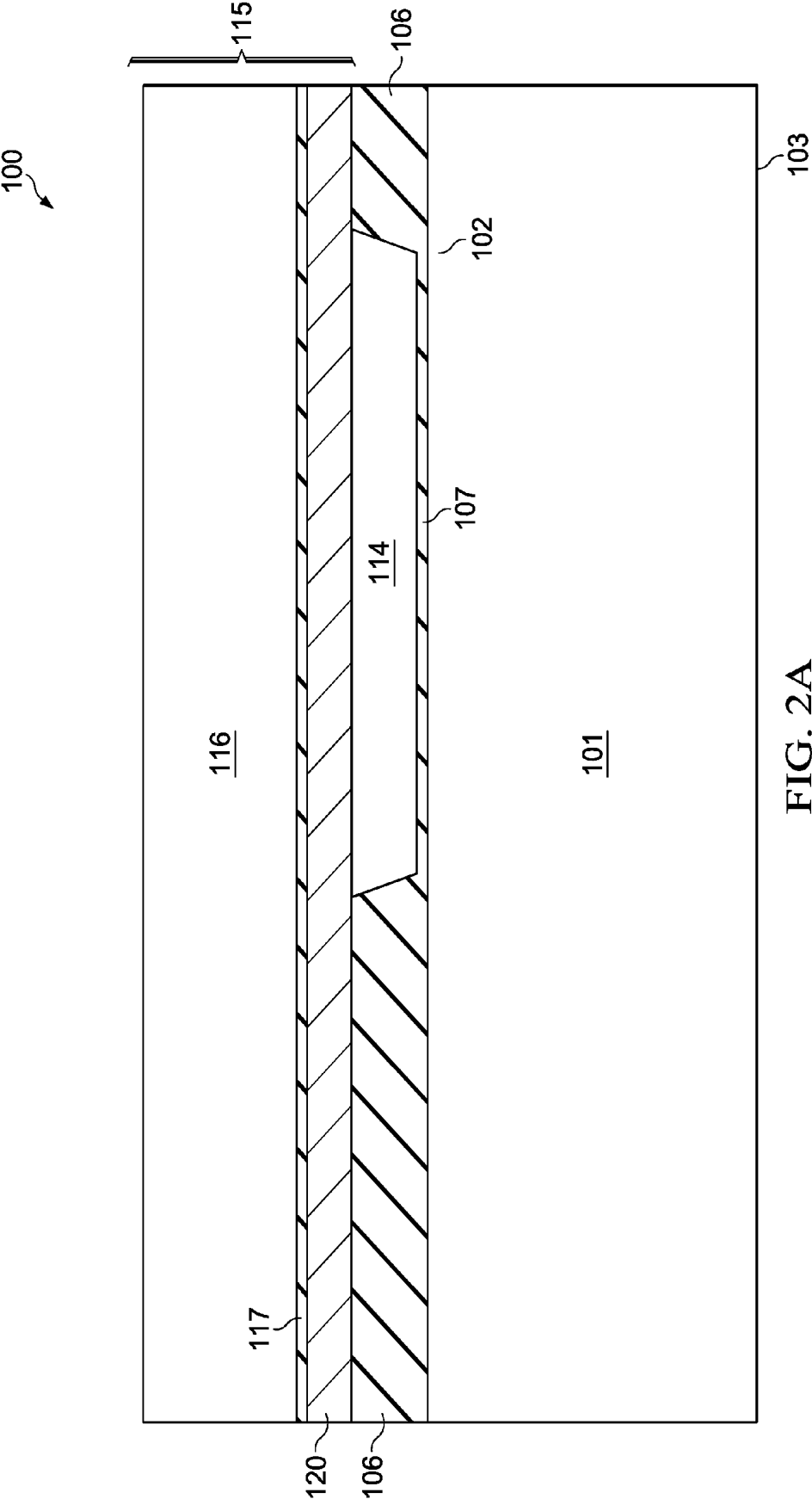

FIG. 2A

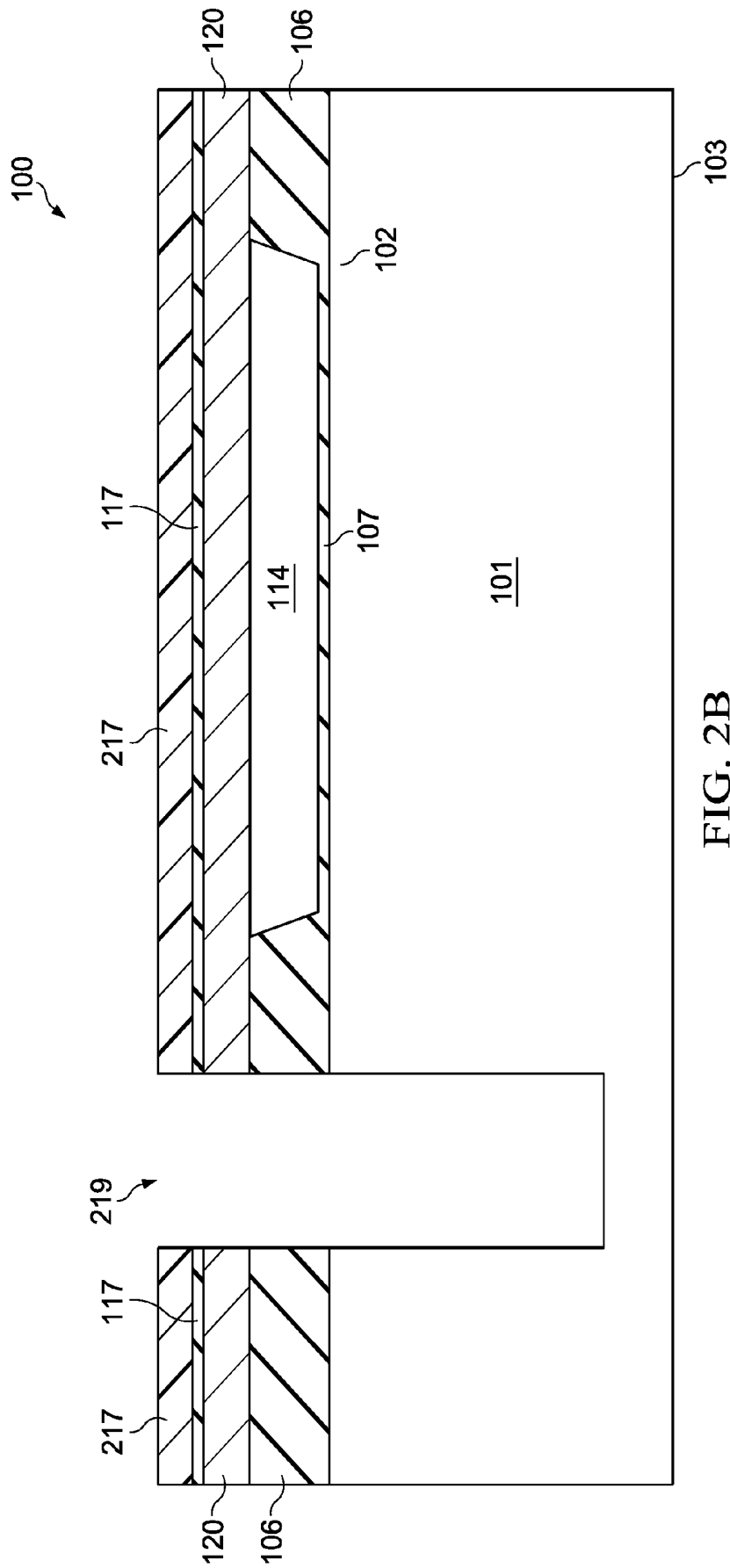

FIG. 2B

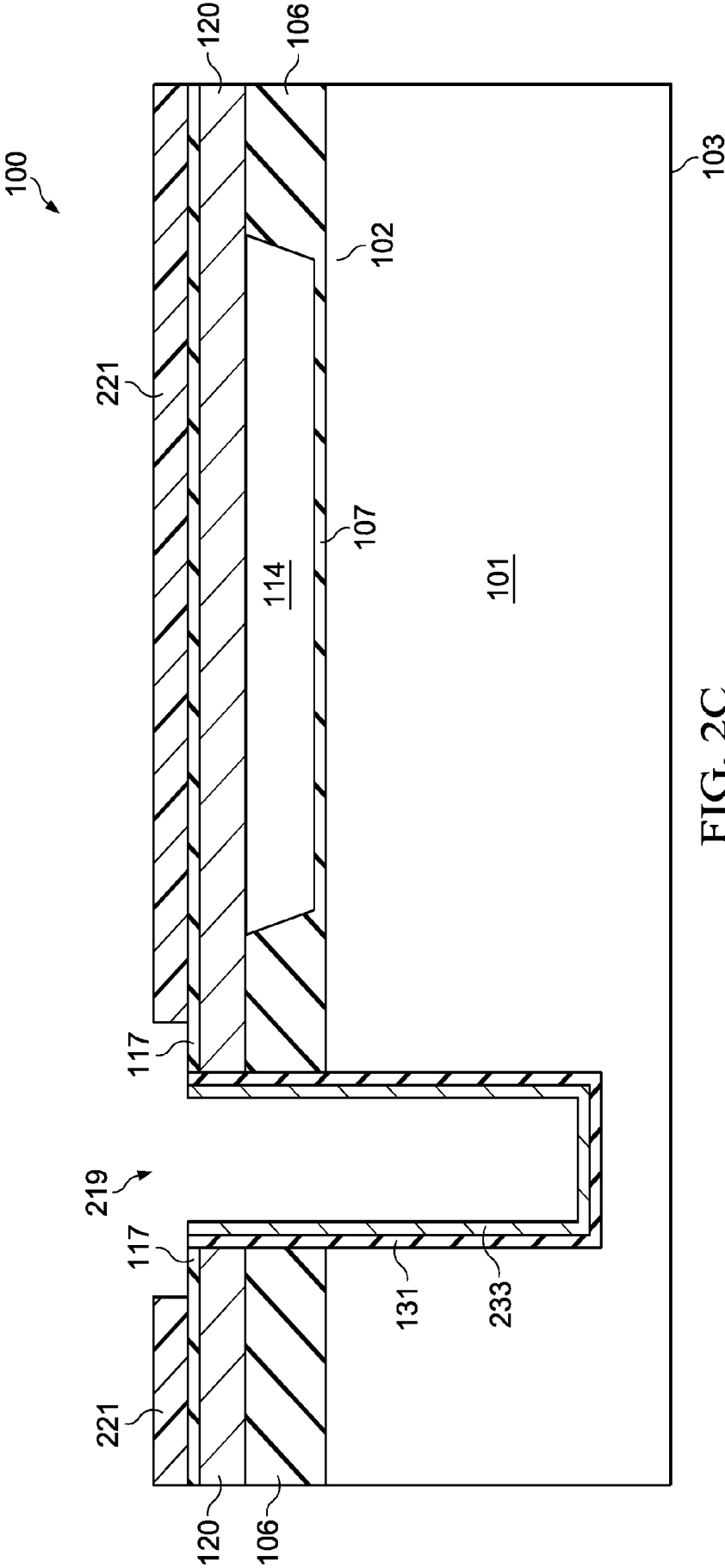

FIG. 2C

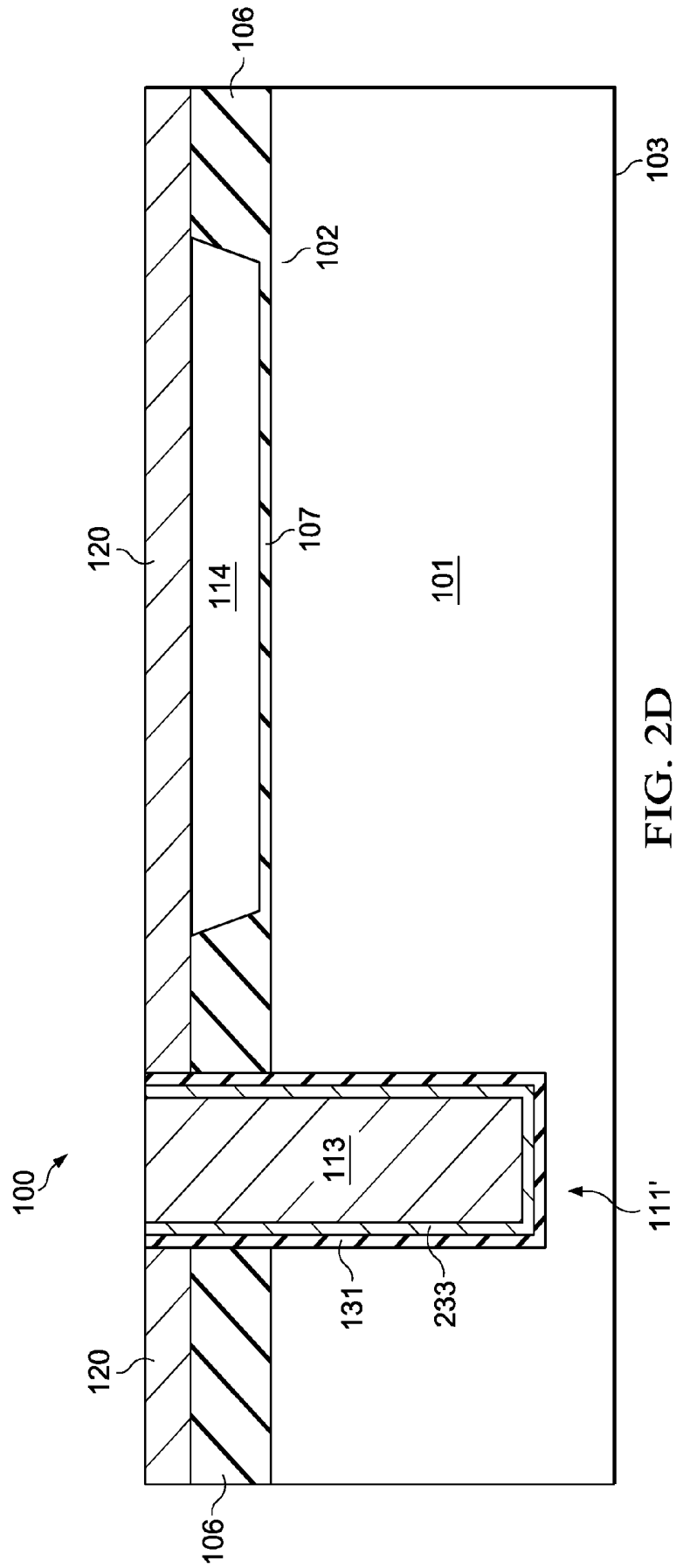

FIG. 2D

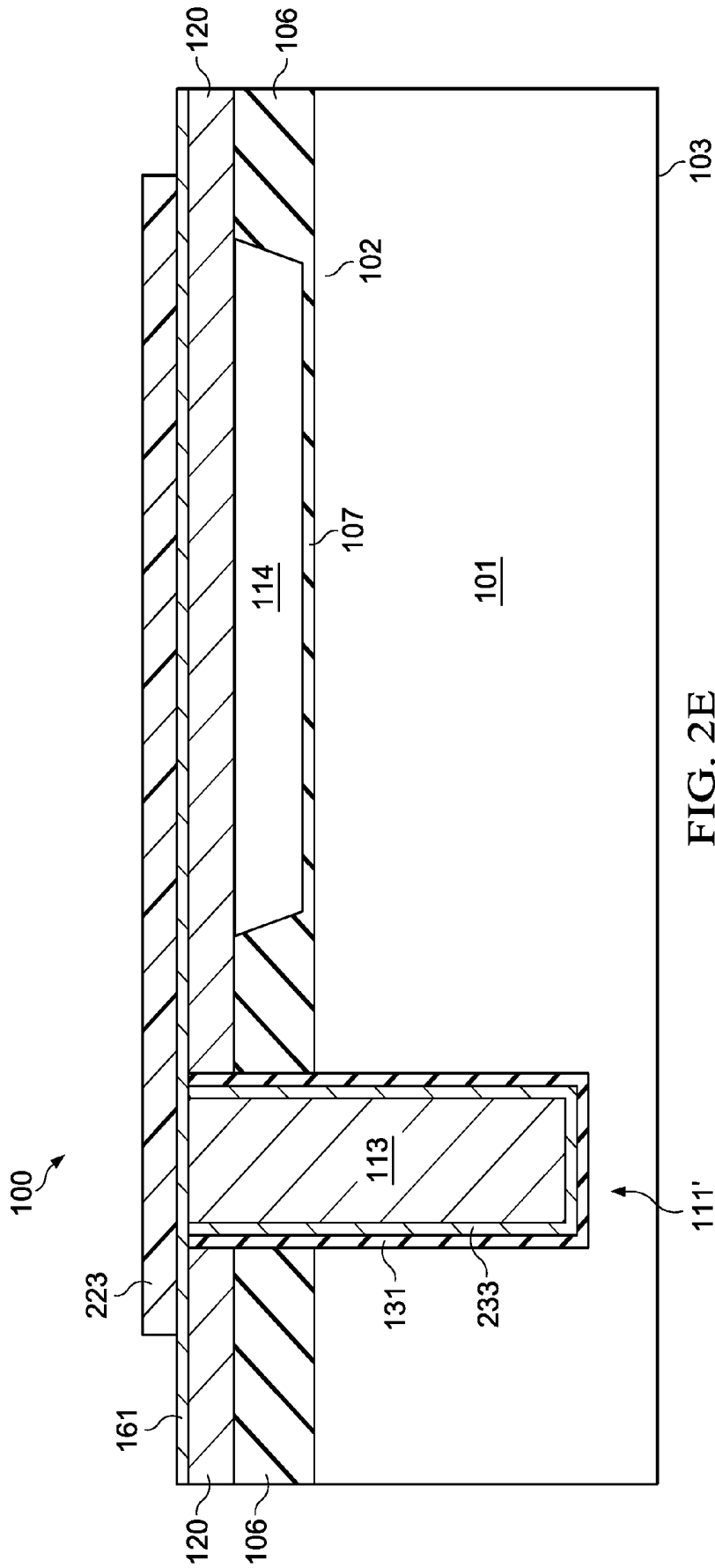

FIG. 2E

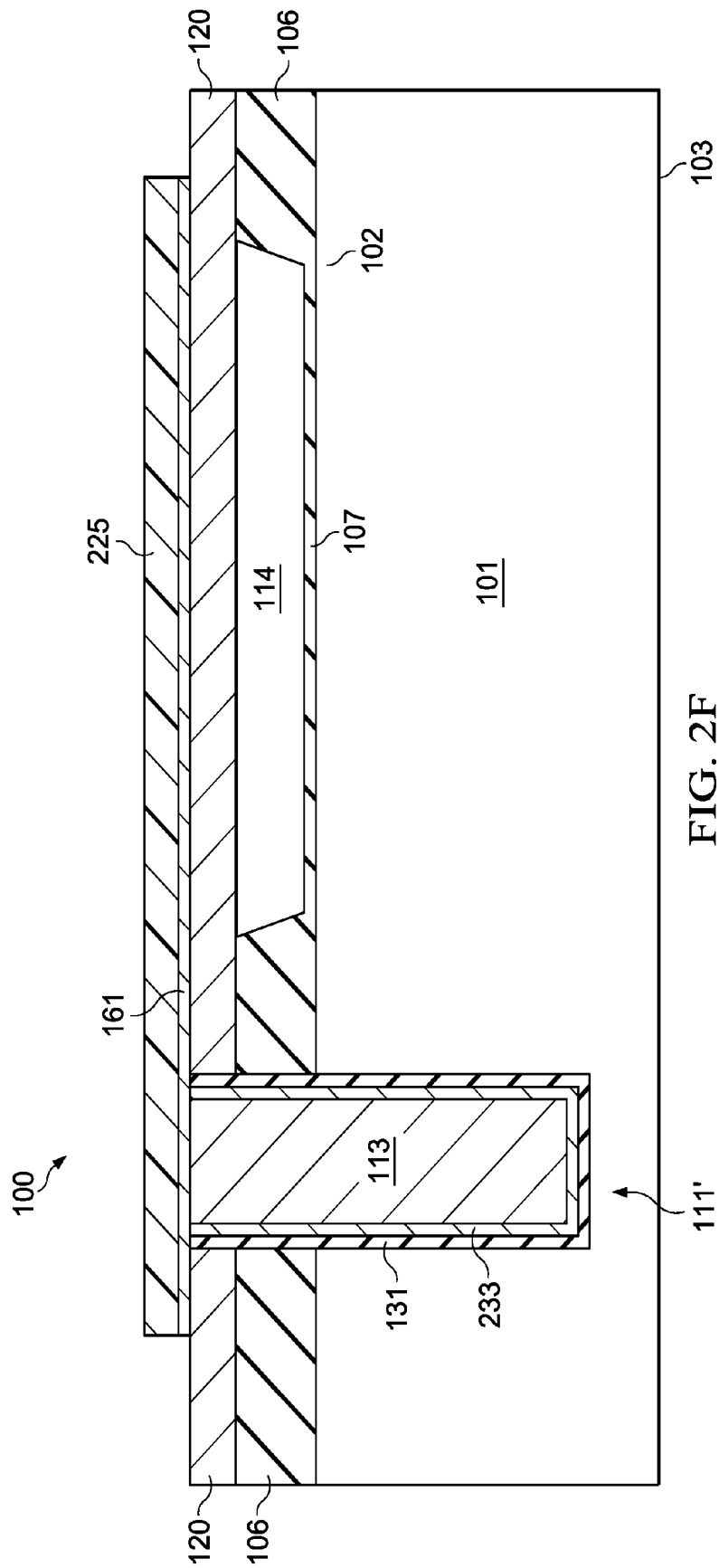

FIG. 2F

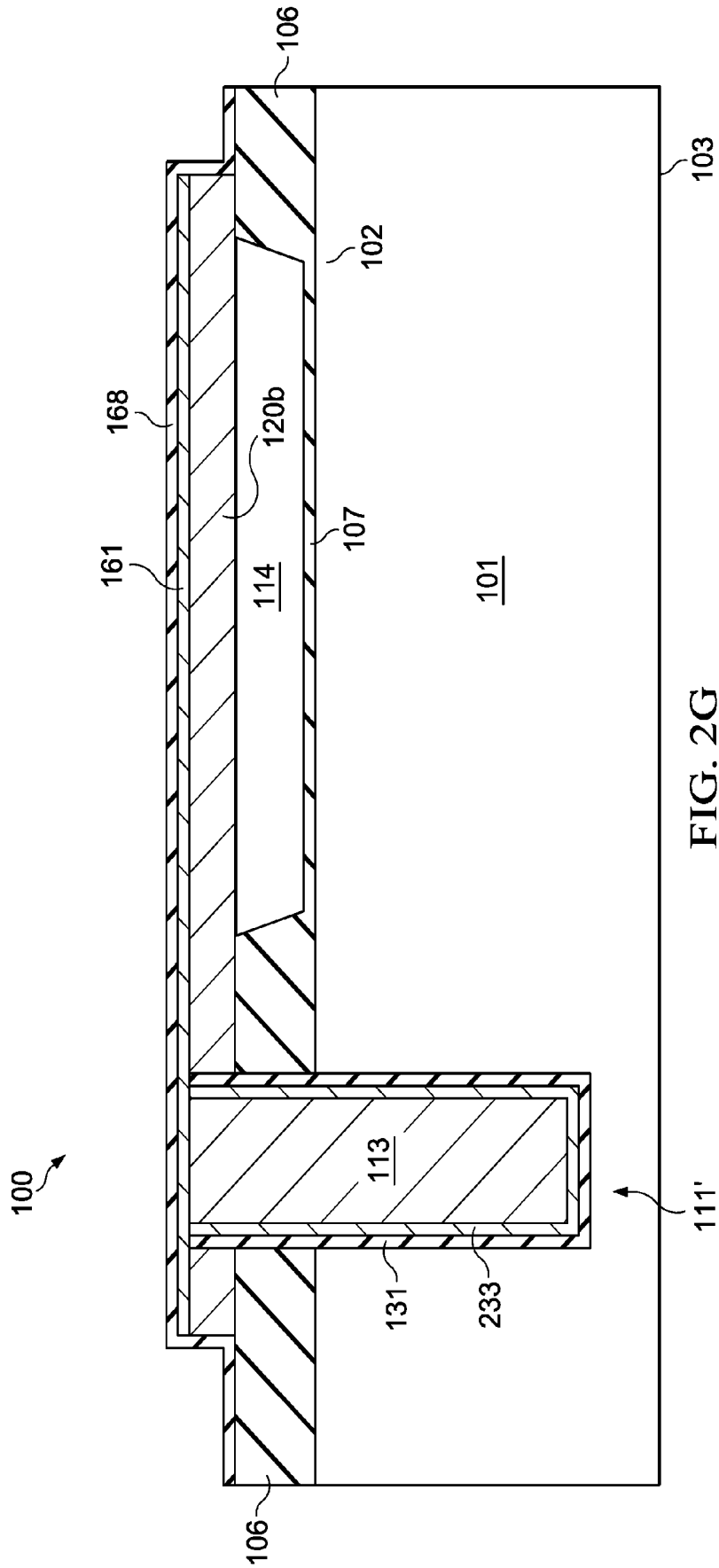

FIG. 2G

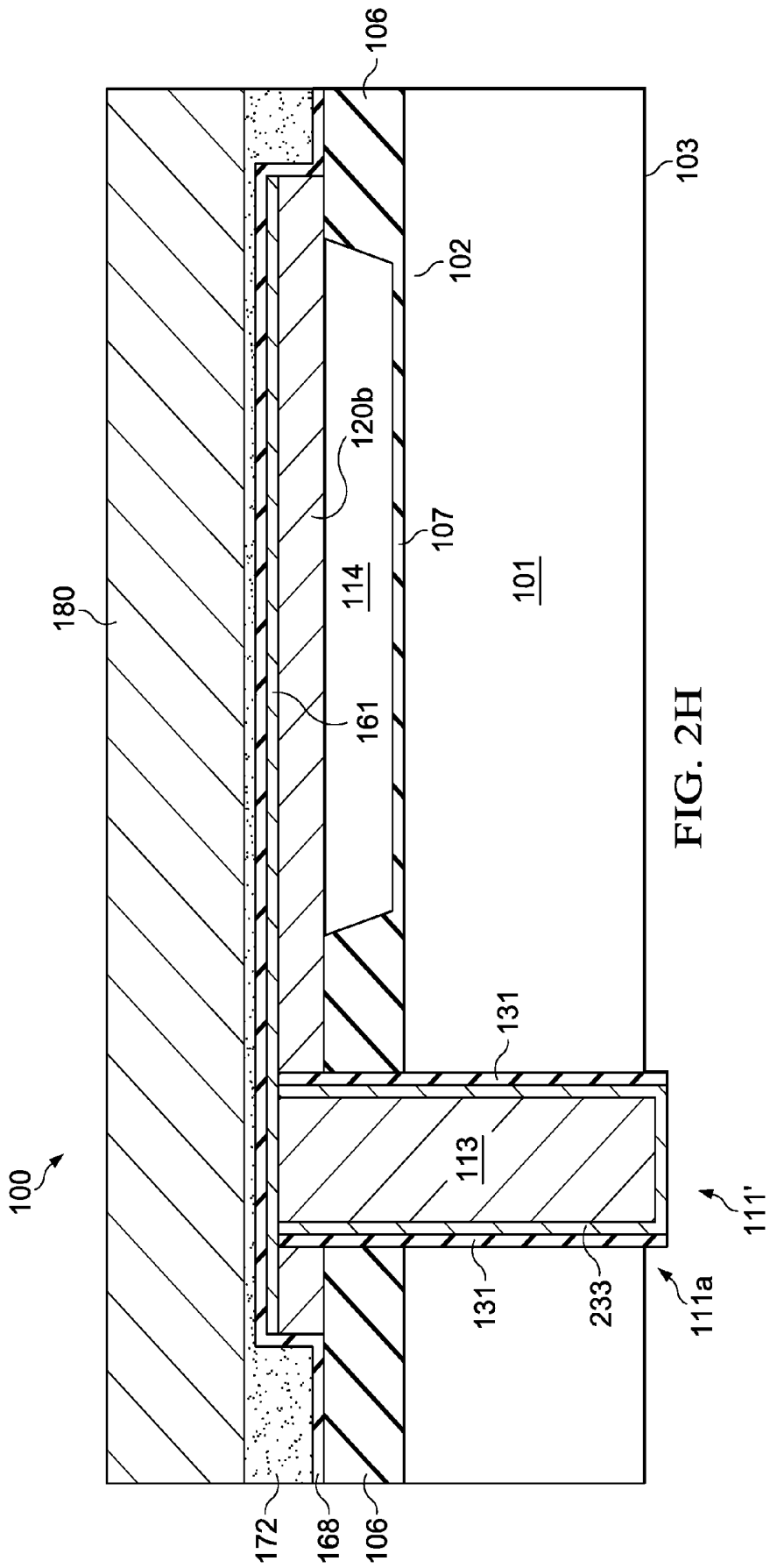
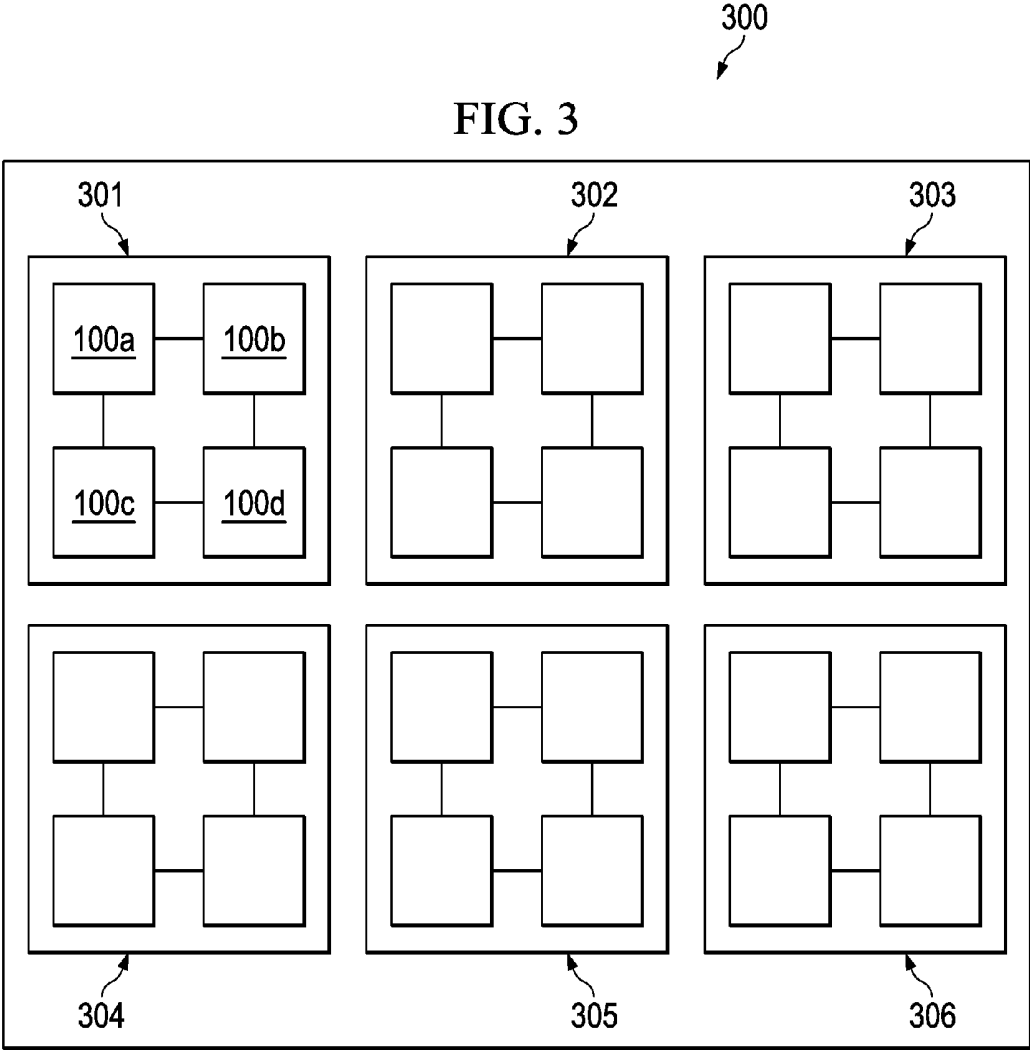

FIG. 2H

FIG. 3



## ULTRASONIC TRANSDUCER DEVICE WITH THROUGH-SUBSTRATE VIA

### CROSS-REFERENCE TO RELATED APPLICATIONS

[0001] Under 35 U.S.C. §120, this continuation application claims benefits of and priority to U.S. patent application Ser. No. 13/779,376 (TI-73087), filed on Feb. 27, 2013, the entirety of which are hereby incorporated herein by reference.

### BACKGROUND

[0002] Capacitive micromachined ultrasonic transducer (CMUT) devices are becoming increasingly popular in medical applications. For example, CMUT devices have been used to improve medical ultrasound imaging probes. CMUT devices have also been used to provide high-intensity focused ultrasound for use in medical therapy. Conventional CMUT devices are typically produced directly on a silicon substrate (i.e. on a silicon wafer). For instance, conventional CMUT devices are often fabricated using a micro-electro-mechanical system (MEMS) manufacturing technique in which a release layer is etched out, leaving a free-standing (flexible) membrane. The top of the membrane is metalized to provide a top (electrode) plate, and the membrane is then used as a transducer to transmit and receive ultrasonic signals.

[0003] Conventional CMUT devices utilize bond pads to provide electrical contact to the top plate for each of the CMUT elements in the device, such as a plurality of bond pads for a CMUT device including a plurality of CMUT elements arranged in a CMUT array. Since the bond wire is elevated above the bond pad, the bond pad is placed remote from the CMUT elements in the CMUT array to facilitate packaging. This constraint not only increases the CMUT device die size due to the need for interconnect routing lines, but it also complicates the packaging process. Both the increased die size and the complicated packaging process increase the cost of packaged CMUT die.

### SUMMARY

[0004] Disclosed embodiments describe solutions to the CMUT device problems with conventional utilization of bond pads for connection to the top plate of each CMUT cell which is recognized to substantially constrain the design and increase size of CMUT devices including 2 dimensional (2D) CMUT arrays of CMUT elements, and also impair their performance. To connect the bond pads to each CMUT element of a conventional large 2D CMUT array involves extensive use of metal interconnect traces on the top side of the CMUT die, thereby increasing the die size and reducing CMUT performance. For CMUT arrays containing a large number CMUT elements (e.g., >10×10 array of CMUT elements) the use of metal interconnect traces to provide contact to each element generally becomes prohibitively complicated for the internal elements, and alternative connection schemes are needed. One such connection scheme is the use of through-substrate connections.

[0005] Disclosed embodiments include CMUT devices having through-substrate vias (TSVs) which allows bottom side device (die) contact to make connections to the top plate (top electrode) of the CMUT cells or CMUT elements including a plurality of CMUT cells through the die to

facilitate the production of 2D CMUT arrays. For CMUT devices having a plurality of CMUT elements, the top electrodes are separate for each CMUT element allowing separate addressing of the respective elements using a single TSV for each element, and there is generally a electrically common bottom side electrode (e.g., a solid sheet of Si substrate) for all CMUT elements on the device. In other embodiments the CMUT device can have an electrically common top electrode for all CMUT elements and an individual bottom electrode for each element to allow separate addressing of the respective elements.

### BRIEF DESCRIPTION OF THE DRAWINGS

[0006] Reference will now be made to the accompanying drawings, which are not necessarily drawn to scale, wherein:

[0007] FIG. 1A is a top view depiction an example CMUT device shown as a CMUT element with a single CMUT cell, according to an example embodiment.

[0008] FIG. 1B is cross sectional depiction of the example CMUT device/element/cell shown in FIG. 1A along the cut line A-A' shown.

[0009] FIGS. 2A-H are cross-sectional diagrams showing processing progression for an example method of forming a CMUT device, according to an example embodiment.

[0010] FIG. 3 is a top view depiction an example CMUT device including a plurality of CMUT elements each including a plurality CMUT cells shown in FIGS. 1A and 1B, according to an example embodiment.

### DETAILED DESCRIPTION

[0011] Example embodiments are described with reference to the drawings, wherein like reference numerals are used to designate similar or equivalent elements. Illustrated ordering of acts or events should not be considered as limiting, as some acts or events may occur in different order and/or concurrently with other acts or events. Furthermore, some illustrated acts or events may not be required to implement a methodology in accordance with this disclosure.

[0012] Regarding nomenclature used herein, the smallest CMUT sensor entity is a CMUT sensor cell. Multiple CMUT sensor cells can be connected in parallel (e.g., with an electrically common movable membrane **120b**) to form a CMUT element. A CMUT element can have any number ( $\geq 1$ ) of CMUT cells. Typically, the more CMUT cells in an element the greater the ultrasonic output pressure that the element can generate responsive to a given stimulus. A CMUT array (device/die) can have any number of CMUT elements. One of the electrodes (e.g., top) of the respective CMUT elements can be electrically isolated from the other electrodes (e.g., top) of the other CMUT elements to allow each CMUT element to be connected independently to be individually addressable. As described herein, having the movable membranes **120b** for each CMUT cell in a CMUT element be electrically common allows addressing of all cells in the CMUT element by a single TSV.

[0013] FIG. 1A is a top view depiction an example CMUT device **100** shown as a CMUT element with a single CMUT cell **100a**, according to an example embodiment. A cut line A-A' is provided for the cross sectional depiction shown in FIG. 1B and other FIGS. 2A-H described below. The CMUT cell **100a** includes a through-substrate via (TSV) **111**, and a first substrate **101** of a single crystal material (e.g., bulk

single crystal silicon or a silicon epitaxial layer on a single crystal substrate) having a top side **102** and a bottom side **103**.

[0014] As shown in FIG. 1B, the top side **102** includes a patterned dielectric layer thereon including a thick dielectric region **106** and a thin dielectric region **107**. The TSV **111** extends a full thickness of the first substrate **101** to the top surface of the membrane layer **120**. The TSV **111** is electrically isolated from the first substrate **101** and membrane layer **120** by a dielectric liner **131**. Although the dielectric liner **131** is shown along the full length of the TSV **111** including on the sidewalls of the thick dielectric region **106**, in the case of a thermally formed dielectric liner **131** (e.g., silicon oxide), as opposed to a deposited dielectric liner **131**, the dielectric liner **131** will not grow on the sidewalls of the thick dielectric region **106**, and thus not be on the sidewalls of the thick dielectric region **106**. TSV **111** includes a TSV filler material **113**, such as Cu in one particular embodiment. TSV **111** is also shown including optional protruding TSV tips **111a** which protrude from the bottom side **103** of the first substrate **101**.

[0015] The membrane layer **120** of a second substrate shown as a silicon on insulator (SOI) substrate **115** (depicted in FIG. 2A) is bonded to the thick dielectric regions **106** and is over the thin dielectric regions **107** of the first substrate **101** to provide a movable membrane **120b** over the MEMS cavity **114** shown. The bonding can comprise vacuum bonding, such as vacuum fusion bonding. A patterned top side metal layer (e.g., an AlCu layer) **161** is over the top of the TSV **111** and over the top of the movable membrane **120b** including a metal layer portion coupling the TSV **111** to the movable membrane **120b**. A dielectric passivation layer **168** is shown over the top of the CMUT cell **100a**.

[0016] The first substrate **101** can comprise single crystal silicon, or epitaxial silicon on single crystal silicon. The first substrate **101** typically has a resistivity less than or equal to ( $\leq$ )  $0.1\Omega\text{-cm}$ , and can be doped p-type or n-type. CMUT cell **100a** is shown including a patterned metal layer **167** on a bottom side **103** of the first substrate **101** which provides a first electrode contact on a bottom side **103** of the CMUT cell **100a** to realize a fixed electrode. As noted above, in the case of a CMUT device including a plurality of CMUT elements each including a plurality of CMUT cells **100a**, the fixed electrode contact provided by patterned metal layer **167** is to a common bottom side fixed electrode (e.g., a solid sheet of the first substrate **101**, such as a Si sheet) for all CMUT elements on the CMUT device.

[0017] TSV **111** provides a bottom side connection to movable membrane **120b** which provides a top plate for the CMUT cell **100a** of the CMUT device **100**. As noted above, for CMUT devices having a plurality of CMUT elements, the top electrodes can be separate for each CMUT element allowing separate addressing of the respective elements using a respective TSV **111** for each element. No top side contact, nor bond pads are thus needed by the CMUT device **100**.

[0018] It is noted CMUT device thicknesses and dimensions can be adjusted to fit specific applications. For example, typical example dimensions for an airborne ultrasound application at **180** kHz operation is a CMUT cell having a movable membrane **120b** 1.12 mm in diameter, a patterned top side metal layer **161** plate width of 1.32 mm

(100  $\mu\text{m}$  plate overlap of the top side metal layer **161** on the sides of the CMUT cell **100a**), and a movable membrane **120b** thickness of 14  $\mu\text{m}$ .

[0019] FIGS. 2A-2H are cross-sectional diagrams showing processing progression for an example method of forming CMUT devices during different stages of fabrication, according to an example embodiment. Although the CMUT device is described being formed having a single element with a single CMUT sensor cell, as noted above disclosed CMUT devices may be formed having a plurality of CMUT elements each with one or more CMUT cells to form a CMUT array having a plurality of CMUT elements (see FIG. 3 described below).

[0020] The embodiment described as shown in FIGS. 2A-H is thus for illustration only and is one particular embodiment which describes formation of a CMUT device having a single CMUT element with a single CMUT cell **100a**. Other techniques for forming disclosed CMUT devices can be used without departing from the scope of this disclosure, including forming CMUT devices including a plurality of disclosed CMUT elements. Several CMUT cells within a CMUT element can be connected in parallel by coupling together movable membranes **120b** of CMUT cells in a given CMUT element, such as to increase the output pressure over a given area. Connecting CMUT cells in parallel reduces the impedance (for driving). The CMUT elements can be electrically isolated from one another for use independently to facilitate beam steering or for improved spatial resolution over a large area. One can also drive/sense the CMUT elements differentially to improve common mode signals or mitigate manufacturing asymmetries.

[0021] Thick dielectric regions **106**, such as comprising a silicon oxide layer, are provided on a top side **102** of a first substrate **101**. First substrate **101** can generally comprise any single crystal substrate material, including silicon-based substrates, or other substrates. The first substrate **101** provides a low substrate resistivity of  $\leq 0.1\Omega\text{-cm}$ , such as about  $0.01\Omega\text{-cm}$ .

[0022] In one particular embodiment, to form thick dielectric regions **106** a thick silicon oxide layer is grown to a thickness of 4.5  $\mu\text{m}$  to 5.5  $\mu\text{m}$  using a high pressure oxidation (HiPOx) process. The use of HiPOx facilitates the rapid growth of thick thermal oxide layers and generally provides good thickness control across the die of typically less than  $\pm 1\%$ . One particular example set of HiPOx process conditions include a temperature of 1,000° C. at 25 atmospheres pressure in steam for 9.5 hours on virgin first substrates **101** (e.g., bulk single crystal silicon wafers), and the alignment marks for photolithography are etched later in the process.

[0023] As an alternative, thick dielectric regions **106** may also comprise conventional thermally grown silicon oxide (e.g., using a Local Oxidation of Silicon (LOCOS) process where silicon dioxide is formed in selected areas (here thick dielectric regions **106**) on a silicon wafer generally using a silicon nitride as a mask to oxidation, or be a deposited dielectric layer, including silicon oxide or other dielectric material. However, the LOCOS approach with conventional oxidation will generally not yield 5  $\mu\text{m}$  thick (or thicker) oxide layers, and deposited dielectric (e.g., oxide) films will generally not provide less than  $\pm 1\%$  thickness control across the die.

[0024] The substrate vendor's laser scribe generally present can be used to ensure a minimum of surface contamination or roughness which will facilitate subsequent wafer bonding steps. Masking and etching of front side alignment marks can follow. Resist strip and a pre-clean process can help ensure a smooth surface for the thick dielectric regions 106 used later in the process for bonding the membrane layer 120 of a SOI substrate 115 or a second substrate such as a standard bulk silicon substrate thereto.

[0025] A first masking level "CELLETCH" uses thick photoresist in order to support the subsequent etch through the thick dielectric regions 106 (e.g., thick silicon oxide layer) to initially begin to define at least one etched single cell CMUT element for each CMUT array/die on the first substrate 101 (e.g., a Si wafer). A plasma etch which is non-polymerizing can be used for etching a first portion of the thick dielectric region 106, such as to etch about 4.65  $\mu\text{m}$  of silicon oxide when thick dielectric regions 106 comprise silicon oxide and have a thickness of about 5  $\mu\text{m}$  to 5.3  $\mu\text{m}$ . A sidewall slope of  $\sim 80^\circ$  is generally desirable and can be achieved from the natural resist erosion. The remaining portion of the thick dielectric region 106 (e.g., 0.5  $\mu\text{m}$  silicon oxide) after plasma etch can be removed by wet etch that provides etch selectivity relative to the substrate material (e.g., Si) to avoid damaging the top side 102 of the first substrate 101.

[0026] About 50% of the top side 102 of the first substrate 101 (e.g., a wafer) will generally be open (exposed) during the etch of the thick dielectric region 106. The resist is then stripped (e.g., a wet strip process). Following an appropriate pre-oxidation clean, in an oxidation step a thin (e.g., 0.3  $\mu\text{m}$ ) CMUT cell oxide can be grown to form thin dielectric regions 107.

[0027] FIG. 2A shows a cross sectional depiction of the CMUT device in-process after vacuum fusion bonding of a SOI substrate (e.g., SOI wafer) 115 comprising a handle (e.g., wafer) 116, buried dielectric layer 117 (generally referred to in the art as a "buried oxide layer" or "(BOX) layer") and membrane layer 120 (e.g., generally referred to in the art of SOI as the "active layer"). The membrane layer 120 is bonded to the thick dielectric regions 106 of the first substrate 101.

[0028] The handle 116 being sacrificial can represent any suitable semiconductor wafer formed from any suitable material(s), such as undoped or lightly-doped (n or p-doped) silicon. The buried dielectric layer 117 also being sacrificial can be any suitable layer(s) of electrically insulative (dielectric) material(s), such as a silicon oxide layer. The membrane layer 120 represents any suitable layer(s) of substrate material(s), such as doped single crystal silicon. In particular embodiments, the handle 116 comprises a silicon wafer with a resistance of about 5 to 10  $\Omega\text{-cm}$ , the buried dielectric layer 117 represents a silicon oxide layer that is about 1.5  $\mu\text{m}$  to 2.5  $\mu\text{m}$  thick, and the membrane layer 120 represents doped silicon with a resistance of about 5  $\Omega\text{-cm}$  is about 14  $\mu\text{m} \pm 5 \mu\text{m}$  thick. For electrical interconnection purposes between cells or elements, the membrane layer 120 can include a metal layer thereon which renders the pathway provided a low resistivity pathway.

[0029] However, as noted above, as an alternative to SOI substrates to reduce cost, a second substrate comprising a standard silicon bulk substrate material (e.g., bulk Si wafer) can be bonded to the thick dielectric regions 106 of the first substrate 101 (CMUT substrate/wafer). In this embodiment,

after bonding, the second substrate material can be thinned by backgrinding and polishing to the desired target membrane thickness, such as 14  $\mu\text{m} \pm 5 \mu\text{m}$  thick.

[0030] For embodiments where the CMUT device/die includes a plurality of CMUT elements (a CMUT array), the membrane layer 120 can be electrically common for all the CMUT cells in each CMUT element. Each CMUT element can have a separate/unique top plate including a plurality of electrically connected movable membranes 120b for the cells within the elements, which can be electrically connected through a dedicated TSV accessible from the bottom side 103 of the first substrate 101. Low resistivity of the top plate of each CMUT element can be provided by subsequent metal deposition on the movable membrane 120b and patterning process steps as described below. Proper known bonding procedures including cleans and plasma pre-treatments can be used.

[0031] For vacuum fusion wafer bonding, as is commonly known in the art, attributes which ensure good wafer bonding include the bonding surfaces being smooth with a surface roughness typically less than 3A. Grown thermal oxide and silicon substrates generally satisfy this requirement. Prior to bonding the surfaces can be treated with an RCA clean (SC-1, where SC stands for Standard Clean), with a 1:1:5 solution of  $\text{NH}_4\text{OH}$  (ammonium hydroxide)+ $\text{H}_2\text{O}_2$  (hydrogen peroxide)+ $\text{H}_2\text{O}$  (water) at 75 or 80° C. typically for 10 minutes. The second RCA clean step is a short immersion in a 1:50 solution of  $\text{HF}+\text{H}_2\text{O}$  at 25° C., in order to remove the thin oxide layer and some fraction of ionic contaminants. The third and last step RCA clean (called SC-2) is performed with a 1:1:6 solution of  $\text{HCl}+\text{H}_2\text{O}_2+\text{H}_2\text{O}$  at 75 or 80° C. This treatment effectively removes the remaining traces of metallic (ionic) contaminants. A  $\text{N}_2$  plasma activation and a DI water rinse can follow. The vacuum bonding is typically performed at a pressure less than  $8 \times 10^5$  mbar. As a final step the bonded surfaces are annealed in  $\text{N}_2$  for several hours, such as a 4 hour 1050° C.  $\text{N}_2$  anneal.

[0032] The handle 116 is then removed after bonding, such as by backgrinding the handle 116 to about a 150  $\mu\text{m}$  post-backgrind target, performing a second 4 hour 1050° C. anneal after backgrinding prior to a wet etch of the handle remaining after backgrind, and then wet etching the remaining handle. The handle remaining after backgrind when the handle 116 comprises silicon can be etched in a wet silicon etch, such as using a hydroxide (e.g., KOH or TMAH), stopping on the buried dielectric layer 117. Masking and etching the movable membrane (e.g., silicon plate) 120b removes the membrane layer 120 over the alignment marks to reopen the alignment marks and enable proper alignment for subsequent process steps. Since the membrane layer 120 is generally a relatively thick layer for etching (e.g., about 14  $\mu\text{m}$  thick), a Bosch etch can compensate for resist erosion during the etch of the membrane layer 120. As known in the art, the Bosch process, also known as pulsed or time-multiplexed etching, alternates repeatedly between two modes/phases to achieve nearly vertical etched structures.

[0033] FIG. 2B shows a cross sectional depiction of the CMUT device in-process after the masking level Mask "TSVHOLE" (Mask #2). The TSV hole (an embedded via) 219 in one particular embodiment is 30  $\mu\text{m}$  in diameter and 150  $\mu\text{m}$  deep (total depth). The resist 217 should be thick enough to support etching through the stack presented, such as a 1.1  $\mu\text{m}$  buried dielectric layer 117, plus a 14  $\mu\text{m}$

membrane layer **120**, plus a 5.1  $\mu\text{m}$  thick dielectric region **106**, plus 130  $\mu\text{m}$  into the first substrate **101**. The TSV hole **219** is then etched. Separate etch tools can be used for etching the buried dielectric layer **117** (e.g. silicon oxide) and Bosch etch for etching the first substrate **101** in the case of silicon.

[0034] The resist **217** is then stripped and a dielectric liner **131** (e.g., a 0.5  $\mu\text{m}$  dielectric oxide) is deposited, or is thermally grown on the semiconductor surfaces within the embedded via/TSV hole **219**. A diffusion barrier metal layer formed on the dielectric liner **131** frames the TSVs and protects against escape of the TSV filler (or core) material **113** into the semiconductor in the case of highly mobile metal TSV filler materials, such as Cu. For example, in one particular embodiment a 0.0875  $\mu\text{m}$  Ta/TaN diffusion barrier metal layer then a 1.5  $\mu\text{m}$  Cu seed layer **233** (see FIG. 2C) is deposited on the dielectric liner **131** for copper TSV filler material **113** embodiments. Alternatively, the seed layer **233** can, for example, comprise copper over titanium.

[0035] FIG. 2C shows a cross sectional depiction of the CMUT device in-process after the masking level Mask "CUMOLD" (Mask #3) which uses resist **221**. This mask can be used to exclude a metal such as Cu from plating over portions of the CMUT cell. Negative resist can be used to ensure the TSV is resist free after masking. The mask is useful since the movable membrane **120b** (e.g., a Si plate) may be deflected by several microns and the subsequent Cu chemical mechanical polishing (CMP) step in the case of copper filled TSVs may not fully remove the copper over the CMUT cells.

[0036] A metal layer is then deposited, such as electroplating a TSV filler material **113**, (e.g., about 15  $\mu\text{m}$  of Cu used) with a subsequent CMP to define the filled TSV hole **219** with the TSV filler material **113**. The resist **221** is then stripped. FIG. 2D shows a cross sectional depiction of the CMUT device in-process after TSV filler material **113** deposition (e.g., Cu), CMP of the TSV filler material **113**, where as shown the metal nail heads from the TSV filler material **113** on the seed layer **233** over and lateral to the embedded TSV **111'** have been removed, and after dielectric liner **131** along with the buried dielectric layer **117** removal over the field area. An anneal step can follow. A second TSV CMP can be used to remove all remaining barrier metal if present (e.g. Cu+TaN). A wet strip may be used to clear residue over the CMUT cell. The dielectric liner **131** along with the buried dielectric layer **117** is then removed stopping on the membrane layer **120** (e.g., Si).

[0037] FIG. 2E shows a cross sectional depiction of the CMUT device in-process after deposition of a top side metal layer **161**, such as 0.5  $\mu\text{m}$  thick AlCu metal layer. Top side metal layer **161** provides the membrane layer **120** plate metallization and connects the membrane layer **120** to the top side of the embedded TSV **111'**. The masking level "ALTOP" (Mask #4) that uses resist **223** is shown which allows etching to define the top side metal layer **161** (e.g., AlCu layer) over the CMUT element(s). The ALTOP CDs can be smaller (e.g., 1  $\mu\text{m}$ /side smaller) than the final to plate dimension. Patterning the top side metal layer **161** before patterning the movable membrane **120** (e.g., Si plate) avoids both top side metal layer **161** and resist step coverage issues. The top side metal layer **161** can be wet etched from the field area using the openings in the resist **223**. The resist **223** is then stripped off

[0038] FIG. 2F shows a cross sectional depiction of the CMUT device in-process after patterning of resist **225** using mask level "PLATESI" (Mask #5). The resist **225** can completely encapsulate the patterned top side metal layer **161** (e.g., AlCu layer). This mask can be larger (e.g., 1  $\mu\text{m}$ /side larger) than the AlCu (ALTOP) mask described above.

[0039] The membrane layer **120** is then etched using resist **225** to separate the CMUT elements for CMUT devices having a plurality of CMUT elements and form the movable membrane **120b** shown. The etch of the membrane layer **120** stops on the thick dielectric regions **106**. A Bosch etch with a short cycle can be used to minimize side wall scalloping. The etch should be configured to not be reentrant. The resist **225** can then be stripped off.

[0040] FIG. 2G shows a cross sectional depiction of the CMUT device in-process after depositing a dielectric passivation layer **168**, such as about a 0.2  $\mu\text{m}$  plasma tetraethyl orthosilicate (TEOS) derived silicon oxide layer, then a 0.2  $\mu\text{m}$  plasma nitride passivation layer, in one particular embodiment. The dielectric passivation layer **168** is shown covering the sidewalls of the movable membrane **120b**. Depending on the CMUT application a thicker passivation stack can be used. A final alloy can be performed, such as at 400° C. in  $\text{N}_2+\text{H}_2$  (forming gas).

[0041] FIG. 2H shows a cross sectional depiction of the CMUT device in-process after optionally bonding the in-process CMUT substrate (e.g., wafer) to a temporary carrier wafer **180** using an adhesive **172**, backgrinding then exposing the TSV on the bottom side **103** of the first substrate **101**, and forming protruding TSV tips **111a**. The backgrind can thin the in-process CMUT substrate (e.g., wafer) close to the embedded TSV, and can remove all bottom side films, and in one particular embodiment about 550  $\mu\text{m}$  of a 725  $\mu\text{m}$  thick Si substrate for first substrate **101** leaving about 175  $\mu\text{m}$ . The bottom side **103** of the first substrate **101** can be etched to expose the TSV tips **111a** leaving first substrate **101** to be about 100  $\mu\text{m}$  thick. One can utilize a Xef plasma etch or wet Si etch, so that the dielectric liner **131** and the barrier metal (if present) are removed to form a TSV tip **111a** having exposed TSV filler material **113** for the TSV **111**. A plasma etch of the dielectric liner **131** and barrier metal will generally leave dielectric (e.g., oxide) spacers on the sidewalls of the TSVs **111** and **112**.

[0042] A metal layer is then deposited on the bottom side **103** of the first substrate, such as a Ti/Ni/Ag layer in one specific embodiment (e.g., 1000 Å Ti+2800 Å Ni+1500 Å Ag). The bottom side **103** of first substrate **101** can be cleaned before the metal layer **167** deposition. A pre-sputter etch of about 300 Å may be used. A masking level "TSVEXP" (mask #6) can then be used to protect areas of the metal layer **167** while it is stripped from the TSV tip **111a**. The CMUT device **100** shown in FIG. 1B described above results (the Cu seed layer **233** not shown in FIG. 1B) after patterning to form a patterned metal layer **167** on the bottom side **103** of first substrate **101**, and stripping of the mask **6** resist. Following dicing (singulation), the resulting CMUT die can be packaged, such as bonded on top of a control die.

[0043] FIG. 3 is a top view depiction an example CMUT device (die) **300** including a plurality of CMUT elements **301-306**, with each capacitive CMUT element including four of the CMUT cells **100a** in FIGS. 1A and 1B shown as CMUT cells **100a-100d** connected together within the element, according to an example embodiment. As described

above, the top electrodes can be separate for each CMUT element allowing separate addressing of the respective elements using a single TSV for each element, where there is common bottom side electrode (e.g., a solid sheet of Si) for all CMUT elements on the device. In other embodiments, the CMUT device has a common top electrode for each element and an individual bottom electrode for each element to allow separate addressing of the respective elements.

**[0044]** Although the CMUT device **300** is shown having six CMUT elements **301-306** with each CMUT element including four CMUT cells **100a-100d**, disclosed CMUT devices can have any number of CMUT elements, each having any number of CMUT cells. The CMUT elements **301-306** can be electrically isolated from one another, connected in parallel on the die or off the die (e.g., by connecting their respective TSVs **111** to a common source) to reduce the impedance (for driving), or can be connected in series (on or off the die) to increase the impedance (for sensing). The respective CMUT elements can be driven/sensed differentially to improve common mode signals or mitigate manufacturing asymmetries.

**[0045]** Advantages of disclosed CMUT devices include the full process using as few as 4 mask levels. Other advantages include enabling smaller die size without the need for conventional bond pads which increase die size and require wire bonding to the couple to the ultrasonic transmitting surface (movable membrane **120b**) on the top side of the CMUT device. Disclosed CMUT devices also simplify the packaging operation resulting in easy coupling to the transmitting medium, which reduces the packaging cost. Disclosed CMUT devices also facilitate the option of stacking the CMUT die on a control die since both electrodes are contacted from the bottom side of the CMUT device.

**[0046]** Disclosed embodiments can be used to form semiconductor die that may be integrated into a variety of assembly flows to form a variety of different devices and related products. Those skilled in the art to which this disclosure relates will appreciate that many other embodiments and variations of embodiments are possible within the scope of the claimed invention, and further additions, deletions, substitutions and modifications may be made to the described embodiments without departing from the scope of this disclosure.

What is claimed is:

1. A transducer device, comprising:
  - a substrate having a first side and a second side opposite the first side;
  - a transducer cell, including:
    - a dielectric layer over the first side of the substrate, the dielectric layer having a first region and a second region thinner than and laterally surrounded by the first region to define a cavity;
    - a membrane layer enclosing the cavity and including a movable membrane over the second region of the dielectric layer; and
    - a through-substrate via (TSV) penetrating the substrate, the dielectric layer, and the membrane layer.
2. The transducer device of claim 1, wherein the membrane layer is bonded directly on the first region of the dielectric layer.
3. The transducer device of claim 1, wherein the TSV is free from vertically overlapping the movable membrane.
4. The transducer device of claim 1, wherein the TSV includes a conductive filler extending from the second side of the substrate to be coplanar with the membrane layer.
5. The transducer device of claim 1, further comprising:
  - a metal layer contacting the TSV adjacent to the first side of the substrate, the metal layer extending laterally along the membrane layer and contacting the movable membrane.
6. The transducer device of claim 1, wherein the membrane layer includes a single crystal silicon material.
7. The transducer device of claim 1, wherein the substrate has a resistivity less than or equal to 0.1Ω-cm.
8. The transducer device of claim 1, further comprising:
  - a second transducer cell;
  - a metal layer connecting the second transducer cell to the TSV of the transducer cell adjacent to the second side of the substrate.
9. A transducer device, comprising:
  - a substrate having a first side and a second side opposite the first side;
  - a transducer cell, including:
    - a dielectric layer over the first side of the substrate, the dielectric layer having a first region and a second region thinner than and laterally surrounded by the first region to define a cavity;
    - a membrane layer enclosing the cavity and including a movable membrane over the second region of the dielectric layer;
    - a through-substrate via (TSV) penetrating the substrate, the dielectric layer, and the membrane layer, the TSV including a conductive filler and positioned laterally away from the movable membrane; and
    - a metal layer contacting the conductive filler above the first side of the substrate and extending laterally along the membrane layer to contact the movable membrane.
10. The transducer device of claim 9, wherein the membrane layer is bonded directly on the first region of the dielectric layer.
11. The transducer device of claim 9, wherein the membrane layer includes a single crystal silicon material.
12. The transducer device of claim 9, wherein the substrate has a resistivity less than or equal to 0.1Ω-cm.
13. The transducer device of claim 9, further comprising:
  - a second transducer cell;
  - a second metal layer connecting the second transducer cell to the TSV of the transducer cell adjacent to the second side of the substrate.
14. A transducer device, comprising:
  - a substrate having a first side and a second side opposite the first side;
  - transducer cells, each including:
    - a dielectric layer over the first side of the substrate, the dielectric layer having a first region and a second region thinner than and laterally surrounded by the first region to define a cavity;
    - a membrane layer enclosing the cavity and including a movable membrane over the second region of the dielectric layer; and
    - a through-substrate via (TSV) penetrating the substrate, the dielectric layer, and the membrane layer, the TSV including a conductive filler; and

an interconnect metal layer connecting the conductive fillers of at least two of the transducer cells adjacent to the second side of the substrate.

**15.** The transducer device of claim **14**, wherein the membrane layer is bonded directly on the first region of the dielectric layer.

**16.** The transducer device of claim **14**, wherein the TSV is free from vertically overlapping the movable membrane.

**17.** The transducer device of claim **14**, wherein the conductive filler extending from the second side of the substrate to be coplanar with the membrane layer.

**18.** The transducer device of claim **14**, further comprising: an intra-cell metal layer contacting the TSV adjacent to the first side of the substrate, the intra-cell metal layer extending laterally along the membrane layer and contacting the movable membrane.

**19.** The transducer device of claim **14**, wherein the membrane layer includes a single crystal silicon material.

**20.** The transducer device of claim **14**, wherein the substrate has a resistivity less than or equal to  $0.1\Omega\text{-cm}$ .

\* \* \* \* \*

专利名称(译)	具有穿衬底通孔的超声换能器装置		
公开(公告)号	<a href="#">US20170050217A1</a>	公开(公告)日	2017-02-23
申请号	US15/345741	申请日	2016-11-08
[标]申请(专利权)人(译)	德州仪器公司		
申请(专利权)人(译)	得克萨斯仪器公司		
当前申请(专利权)人(译)	得克萨斯仪器公司		
[标]发明人	JOHNSON PETER B WYGANT IRA OAKTREE		
发明人	JOHNSON, PETER B. WYGANT, IRA OAKTREE		
IPC分类号	B06B1/02 A61B8/00 H02N1/00		
CPC分类号	B06B1/0292 B06B2201/76 A61B8/4483 H02N1/002 H02N1/006 H02N1/008		
其他公开文献	US10335827		
外部链接	<a href="#">Espacenet</a> <a href="#">USPTO</a>		

摘要(译)

电容微加工超声换能器 (CMUT) 器件包括至少一个CMUT单元, 该单元包括具有顶侧的第一衬底, 该顶侧包括在其上的包括厚的和薄的电介质区域的图案化的电介质层。膜层结合在厚电介质区域和薄电介质区域上, 以在微机电系统 (MEMS) 腔上提供可移动膜。穿透衬底通孔 (TSV) 包括从第一衬底的底侧延伸到膜层的顶表面的电介质衬垫。顶侧金属层包括在TSV之上, 在可移动膜上方的第一部分, 并且将TSV耦合到可移动膜。图案化金属层在第一基板的底侧表面上, 包括接触第一基板的与TSV侧向的底侧的第一图案化层部分。

