



US 20080200810A1

(19) **United States**

(12) **Patent Application Publication**
BUCHALTER

(10) **Pub. No.: US 2008/0200810 A1**

(43) **Pub. Date: Aug. 21, 2008**

(54) **ULTRASOUND COUPLING DEVICE**

(52) **U.S. Cl. 600/459**

(76) **Inventor: Neal BUCHALTER, Short Hills, NJ (US)**

(57) **ABSTRACT**

Correspondence Address:
HAHN LOESER & PARKS, LLP
One GOJO Plaza, Suite 300
AKRON, OH 44311-1076

An ultrasound coupling device for transmitting ultrasound waves from an ultrasound transducer to a test specimen, especially to a human or animal body, said coupling device comprising (a) a gel pad (2) for transmitting said ultrasound waves, (b) a support (3) having i) a transducer side (T), ii) a body side (B), and iii) an aperture (11) through said transducer side and said body side of said support (3), (c) said support (3) being provided with an adhesive element (13) on said body side, and (d) said gel pad (2) being received within said aperture (11) such that said gel pad (2) contacts said human or animal body when said body side of said support contacts said human or animal body.

(21) **Appl. No.: 11/675,977**

(22) **Filed: Feb. 16, 2007**

Publication Classification

(51) **Int. Cl. A61B 8/14 (2006.01)**

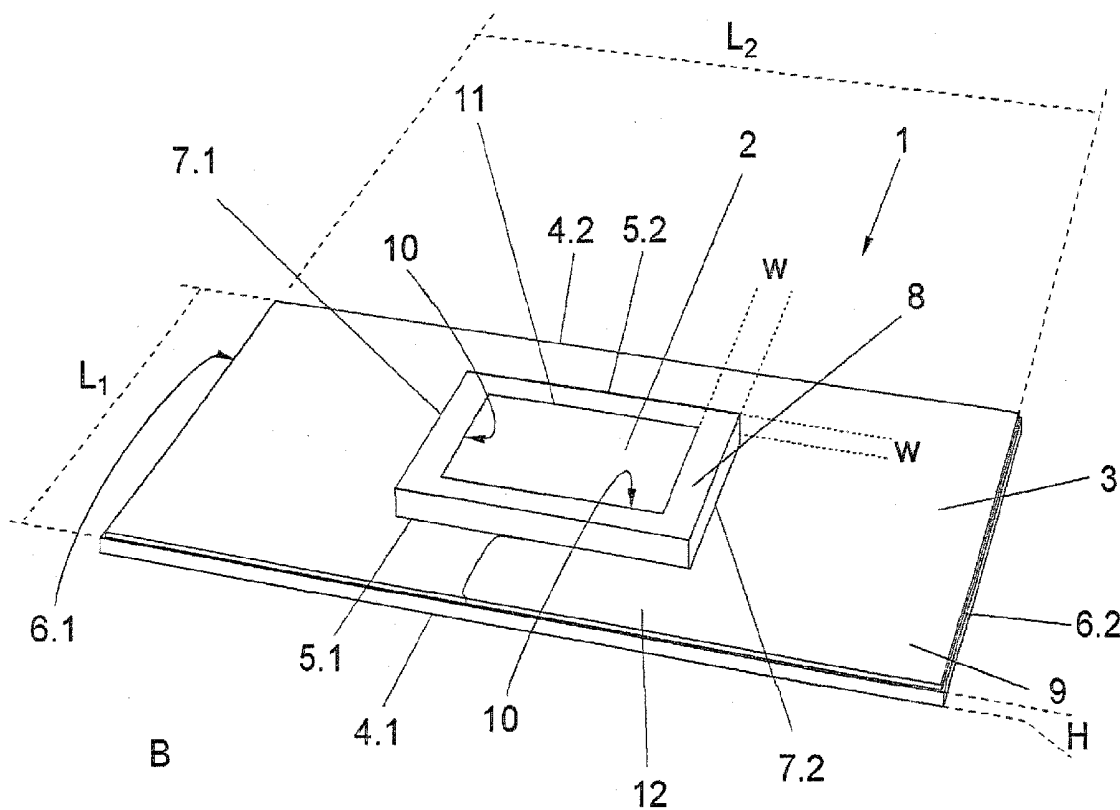

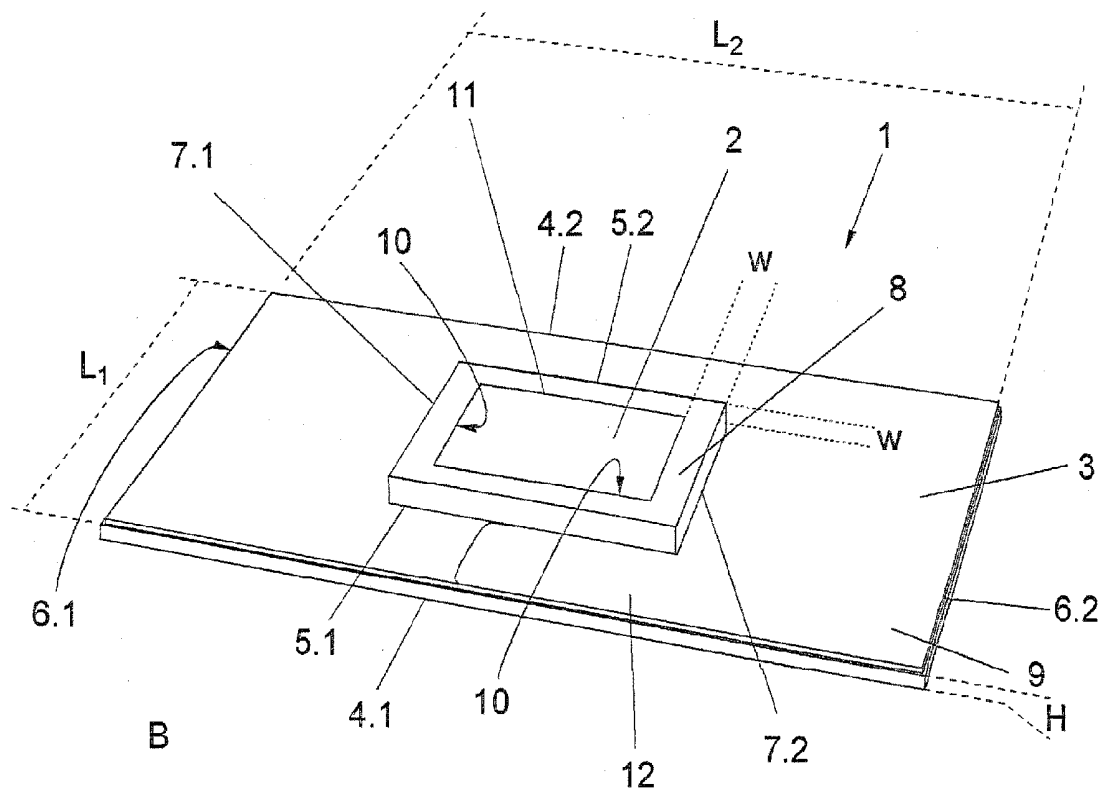

Fig. 1

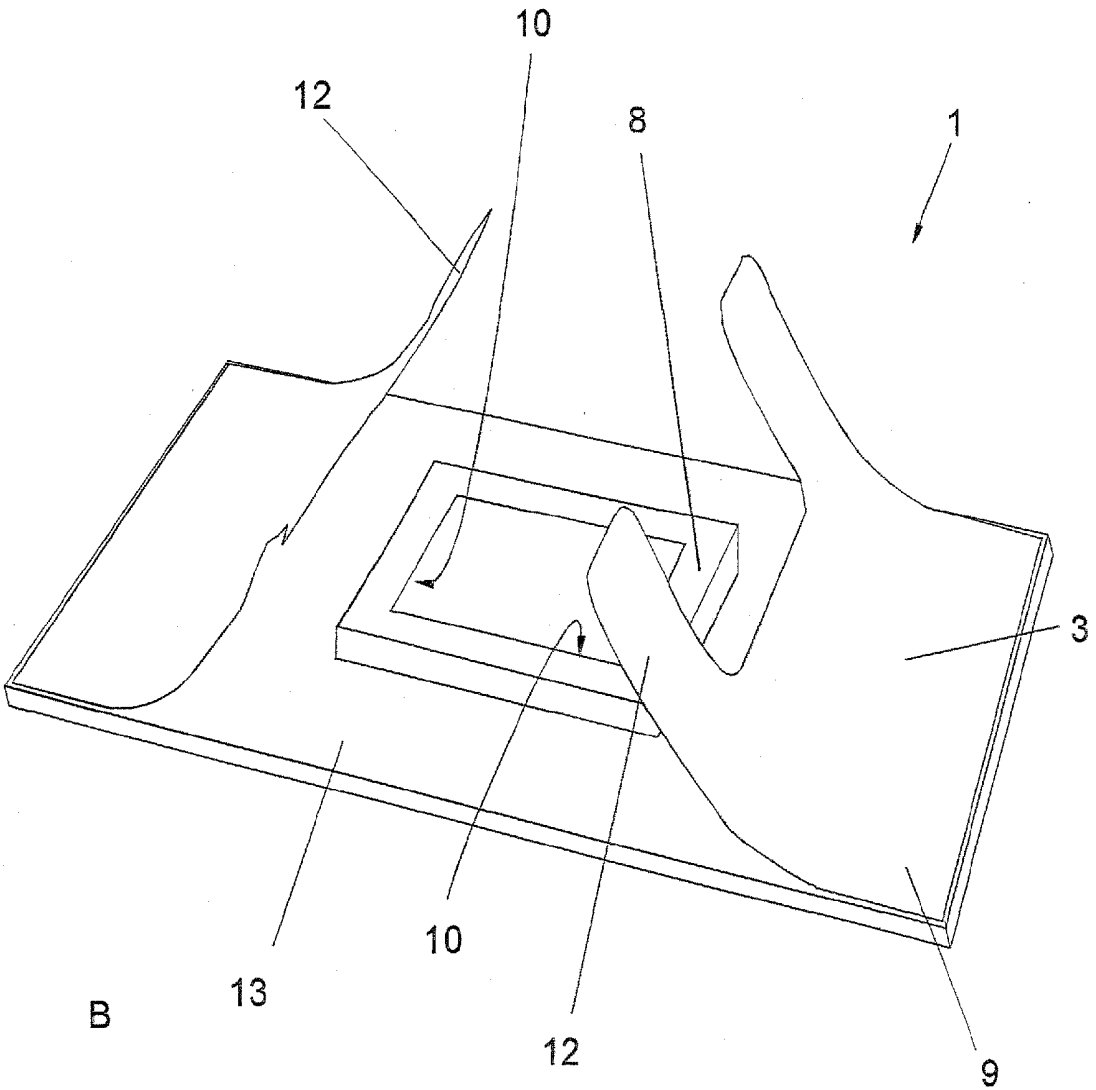

Fig. 2

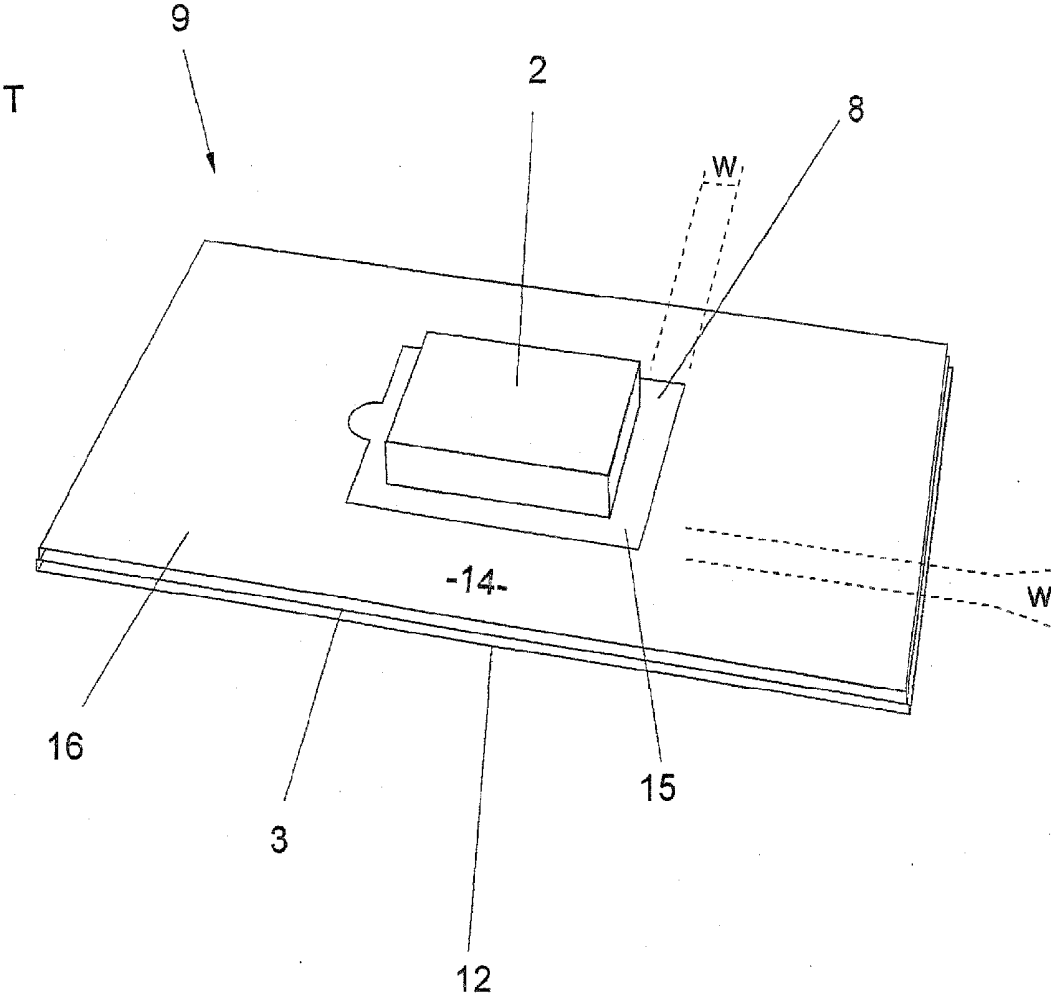

Fig. 3

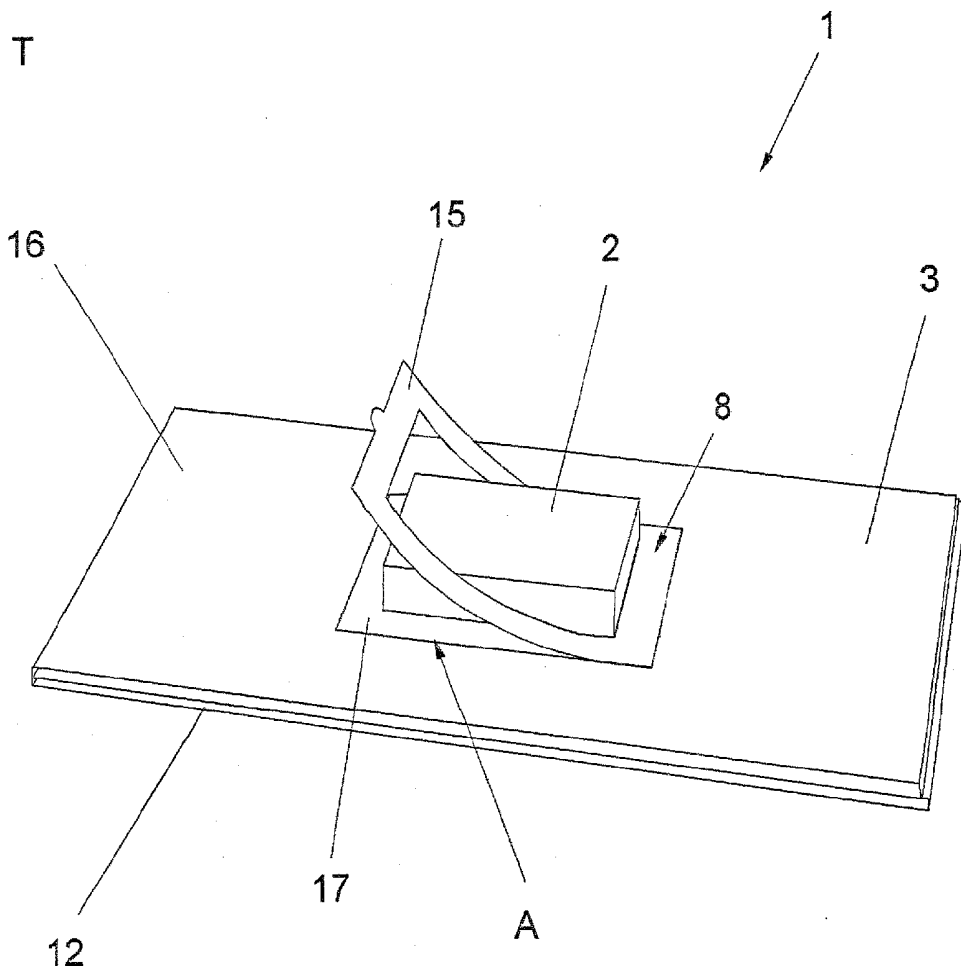

Fig. 4

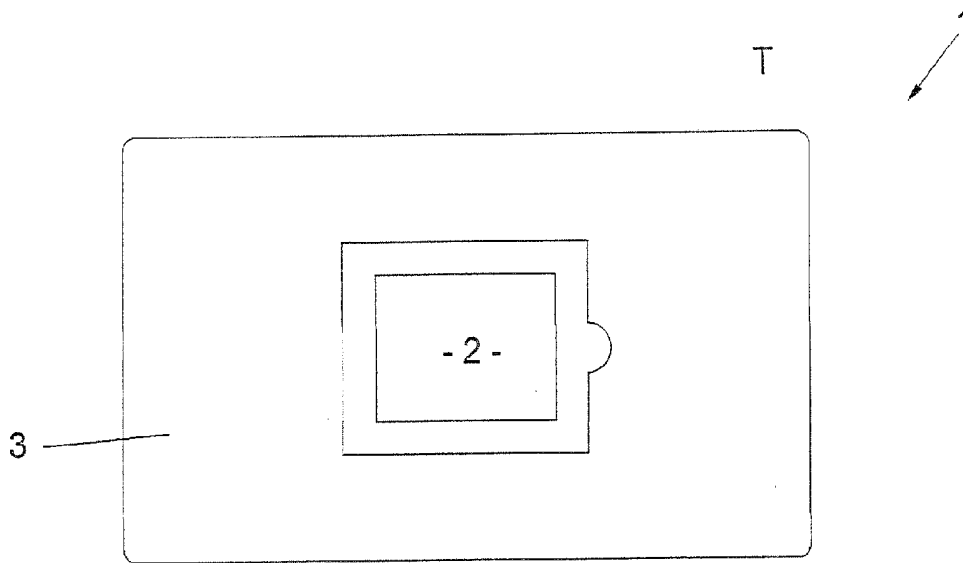

Fig. 5a

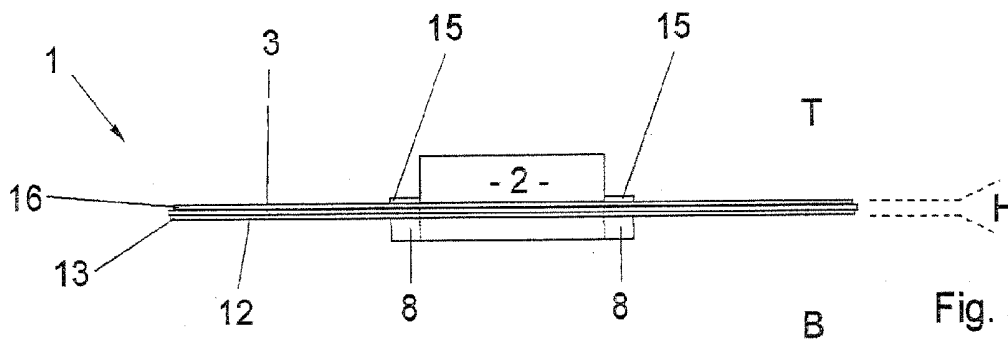

Fig. 5b

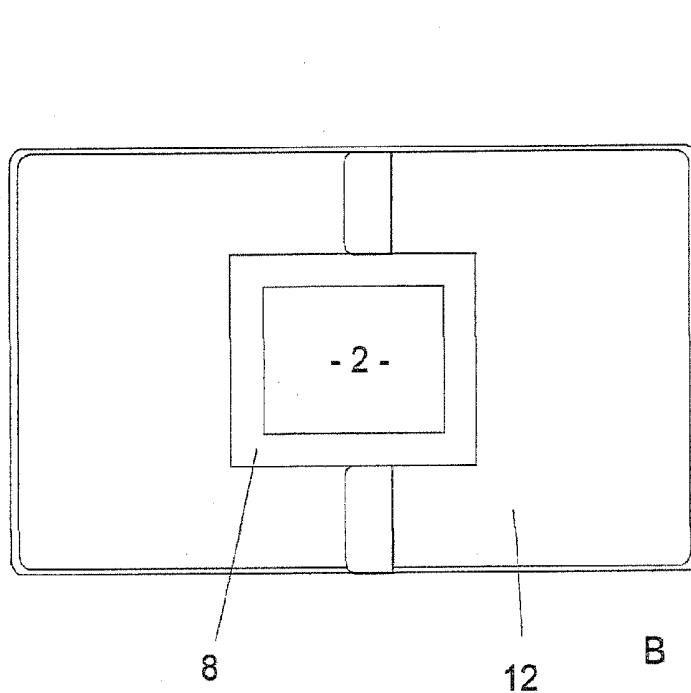

Fig. 5c

ULTRASOUND COUPLING DEVICE

BACKGROUND OF THE INVENTION

[0001] 1. Field of the Invention

[0002] The invention relates to an ultrasound coupling device for transmitting ultrasound waves from an ultrasound transducer to a human or animal body, wherein that coupling device comprising a solid gel pad for transmitting said ultrasound waves and a self-adhesive material for attaching the ultrasound transducer to the patient.

[0003] 2. Background

[0004] Ultrasound is used in a variety of medical treatment methods. Especially, ultrasound is used to promote the healing of soft tissue injuries. Ultrasound is also used for monitoring a human or animal body, for example, for monitoring the velocity of a blood stream or the position of veins or arteries. Ultrasound is used for imaging the internal organs and systems of the body and for diagnosing abnormalities.

[0005] It is known, for example from US 2002/0049395 A1, to apply ultrasound to the thoracic cavity for cardiac rehabilitation over an extended treatment period. From U.S. Pat. No. 5,458,140 it is also known that the application of ultrasound can enhance transdermal drug delivery. Both applications require fixing a transducer head to the body for a long time.

[0006] Ultrasound waves are produced with an ultrasound transducer head and transmitted to the human or animal body via an ultrasound couplant. The ultrasound couplant reduces reflection of the ultrasound waves and thus increases the amount of ultrasound wave energy that is coupled into the body.

[0007] To enhance the focusing of an ultrasound transducer head, gel pads are used as couplants that are made of acoustically inert material. In particular, gel pads are used in cases when an ultrasound beam needs to be focused close to the surface of the skin.

[0008] For long term therapy existing devices may use a strap or other fixation device to fix the ultrasound transducer head and the gel pad to the human or animal body. It is a disadvantage that these methods/devices may hamper blood circulation. Additionally, many patients regard these kinds of methods/devices as uncomfortable.

[0009] Thus, the invention relates to the problem of mitigating disadvantages in known ultrasound coupling devices.

SUMMARY OF THE INVENTION

[0010] One object of the invention is to develop an ultrasound coupling device which has a simple structure and is easy and inexpensive to manufacture. For long term applications the ultrasound coupling device must to be removed frequently, for example to allow the patient to take a shower. Therefore, it is desirable to provide an inexpensive ultrasound coupling device that can be used as a disposable product.

[0011] The inventive coupling device can be adhered to a patient's body, where the patient may be an animal or a human being, so that no bandage or strap is needed. Further, the blood circulation is not hampered and the ultrasound device according to the invention can be worn for a long time and in a comfortable way.

[0012] It is a further object of the invention to provide a tight and safe coupling between the ultrasound transducer and the patient's skin. The adhesive element holds the ultrasound coupling device in place and ensures a tight fit to the patient's

skin. The gel pad is designed to precisely fit inside the cavity of the transducer in order to provide sufficient contact.

[0013] Yet another object of the invention is to provide more comfort for patients. As the ultrasound coupling device is flat it can be worn under the clothes so that it is invisible to other persons. Further, the ultrasound coupling device has a low weight, which contributes to the wearing comfort. Due its simple construction, the ultrasound coupling device according to the invention can be manufactured as a throwaway product and can be changed regularly. This leads to an increased comfort for the patient.

[0014] In accomplishing the foregoing objects, there has been provided, according to the present invention, an ultrasound coupling device for transmitting ultrasound waves from an ultrasound transducer for a test specimen such as a human or animal body, said coupling device comprising a gel pad for transmitting said ultrasound waves that further comprises a support having a transducer side, a body side and an aperture to said transducer side and said body side, said support being provided with an adhesive element on said body side, and said gel pad being received within said aperture such that gel pad contacts said human or animal body if said body side of said support contacts said human or animal body.

[0015] In particular, a gel pad is a dimensionally stable body that contains or consists of a gel. The gel acts as a couplant, i.e. as a material that facilitates the transmission of ultrasonic energy from the transducer into the test specimen, especially into the human or animal body. Preferably, the gel pad is made from a gel that does not dry out when it is in contact with ambient air. Additionally, the gel is preferably not hygroscopic so that its consistency does not change during application. The gel may include a content of salts which is approximately equivalent to the content of salts in the human or animal skin so that no osmosis takes place when the gel pad is brought into contact with the skin.

[0016] The support may be any element that provides a stable connection between the skin of the human or animal body and the gel pad when the ultrasound coupling device is adhered to the human or animal body. The support may be made from plastics, rubber, latex, a woven textile, and a non-woven and may comprise reinforcing elements.

[0017] The adhesive element may have any shape. However, it is preferred that the adhesive element covers the entire or almost the entire body side of the support. This yields a strong and tight fit of the support to the skin of the human or animal body. It is preferred, but not necessary, that the adhesive element is homogeneous all over the body side of the support. It is possible that the support is provided with a plurality of adhesive elements, for example in form of concentric rings or polygons that encircle the aperture.

[0018] In a preferred embodiment the gel pad has an edge and is encircled by a frame along this edge. This frame isolates the gel pad from ambient air and dirt. Further, this frame prevents liquid from the gel pad from leaking out and thus protects clothes of the patient from being contaminated with gel.

[0019] It is preferred that this frame is made of a foam. Foam is elastic, easy, light-weight, easy to manufacture, and waterproof. Further, the foam can be used to soak in an adhesive in case this is needed. In a preferred embodiment this foam is a reticulated foam. The reticulated foam becomes integrated into the gel pad due to the pores inherent in the foam and thus provides a safe hold of the gel pad. The edges

of the foam are adhered to the support so that the foam is securely fixed to the support. That way, the reticulated foam enables the attachment of the gel pad to the skin adhesive.

[0020] The adhesive element may be capable of securely fixing the ultrasound coupling device to the human or animal body. The adhesive element may be such that it does not irritate the skin and provides for a sufficient adhesive force to couple the ultrasound transducer to a human or animal body for more than one day.

[0021] Preferably, said support comprises a liner covering said adhesive element. The liner protects the adhesive element against dirt, grease, and humidity and thus preserves it against loss of adhesive force during storage.

[0022] It is preferred that the adhesive element is a pressure-sensitive film. Pressure-sensitive films combine strong adhesion to little weight and small thickness.

[0023] In a preferred embodiment, the support is a flat patch. A flat patch is flexible and fits to uneven or curved parts of the human or animal body such as legs, arms, and so on.

[0024] Preferably, the flat patch has a width, a length, and a height, wherein the width or the length are at least ten times larger than the height. The width preferably exceeds six centimeters and the height is less than four millimeters.

[0025] It is preferred that the support comprises a fixing area on the transducer side that comprises a fastener which surrounds the aperture for fixing the ultrasound transducer. This fixing area preferably completely surrounds the aperture. This yields an especially strong connection between the ultrasound coupling device and the ultrasound transducer.

[0026] The fastener is preferably an adhesive that is located in cells of foam, especially in cells of the frame that surrounds the gel pad. This yields a simple construction which is easy to handle and to manufacture. Additionally, the support may include an additional strip of adhesive to further secure the transducer cable.

[0027] To provide for a save hold of the ultrasound coupling device on the human or animal body, the aperture is located close to a center of the support.

BRIEF DESCRIPTION OF THE DRAWINGS

[0028] The foregoing and other objects, aspect and advantages will be better understood from the following detailed description of a preferred embodiment of the invention with reference to the drawings, in which:

[0029] FIG. 1 is a perspective view on the body side of an ultrasound coupling device according to the invention;

[0030] FIG. 2 is a perspective view on the coupling device of FIG. 1 with two parts of a liner partly peeled off;

[0031] FIG. 3 is a perspective view on a transducer side of the ultrasound coupling device of FIGS. 1 and 2;

[0032] FIG. 4 is a perspective view of the transducer side as shown in FIG. 3 with a liner covering a fixing area for an ultrasound transducer being partly peeled of; and

[0033] FIGS. 5a, 5b and 5c are schematic views of the ultrasound coupling device according to FIGS. 1 to 4.

DETAILED DESCRIPTION OF THE DRAWINGS

[0034] Referring now to the drawings, and more particularly to FIG. 1, there is shown a body side B of an ultrasound coupling device 1 comprising a gel pad 2 and a support 3. Gel pad 2 has a substantially rectangular cross-section and consists of an isotonic gel. As the gel is isotonic, it can be brought

into contact with a skin of human or animal body without losing water to the skin or drawing water from the skin.

[0035] Support 3 may have substantially rectangular shape and a height H. Gel pad 2 is located in the center of support 3. Long sides 4.1, 4.2 of support 3 are aligned with long sides 5.1, 5.2, respectively, of the gel pad 2. Accordingly, broadsides 6.1, 6.2 of the support 3 are aligned with broadsides 7.1, 7.2 of gel pad 2. Broadside 6.1, 6.2 have a width L_1 and long sides 5.1, 5.2 have a length L_2 .

[0036] Support 3 comprises a one-piece frame 8 which is made of a reticulated foam or generally of an open-celled foam. Frame 8 has a constant width w, and is irreversibly fixed to a main body 9 of support 3, e.g. by a permanent adhesive. In an alternative embodiment, frame 8 has a circumferential groove that is received in a tongue-and-groove-like manner in main body 9.

[0037] Frame 8 has an inner edge 10 that surrounds an aperture 11 of support 3. The gel pad 2 is received within the aperture 11 (so that gel pad 2 is completely surrounded by inner edge 10 of frame 8) and is thus fixed to support 3.

[0038] Gel pad 2 is flush with frame 8 and both protrude from main body 9. If support 3 is brought into contact with the human body, gel pad 2 and frame 8 come into close contact with the human body as well.

[0039] Referring now to FIG. 2, it can be seen that main body 9 comprises a liner 12 covering an adhesive element in form of a pressure-sensitive film 13. Liner 12 covers the entire surface of pressure sensitive film 13 and can be peeled off to expose the adhesive surface. In the embodiment of FIG. 1, liner 12 does not cover gel pad 2 or frame 8. In an alternative embodiment, liner 12 may also cover those components.

[0040] FIG. 3 shows a transducer side T of support 3. Gel pad 2 protrudes from a main body surface 14 of a flat foam pad 16. Foam pad 16 has the same shape as pressure-sensitive film 13 to which it is fixed. On the transducer side T, frame 8 is covered by a frame liner 15 which can be peeled off.

[0041] Alternate embodiment additional adhesive strips can be positioned on the surface to further secure the transducer or cable/wire. Further alternative additional liner can be positioned on the surface to expose additional adhesive to secure transducer or wire/cable.

[0042] As can be seen in FIG. 4, the transducer side part of the frame 8 acts as a fixing area A for a transducer head (not shown). To fix the transducer head to the support 3, frame liner 15 is peeled off so that an adhesive 17 is exposed. The transducer head comprises a flange that may be fixed to fixing area A by the adhesive 17. The shape and size of the pad is determined by the design of the transducer. The transducer can be virtually any shape.

[0043] FIGS. 5a, 5b and 5c are to scale and show the ultrasound coupling device 1 of FIGS. 1 to 4. FIG. 5a shows transducer side T, FIG. 5b shows a sectional view, and FIG. 5c shows body side B.

[0044] An ultrasound device may be provided for transmitting ultrasound waves from an ultrasound transducer to a human or animal body. The ultrasound device may comprise an ultrasound coupling device (1) comprising a gel pad (2) for transmitting said ultrasound waves, a support (3) having a transducer side (T), a body side (B), and an aperture (11) through said transducer side and said body side of said support (3), said support (3) being provided with an adhesive element (13) on said body side, and said gel pad (2) being received within said aperture (11) such that said gel pad (2) contacts said human or animal body when said body side of

said support contacts said human or animal body; and an ultrasound transducer, said ultrasound transducer comprising a cavity with an ultrasound transducer head, said cavity having a sectional area, wherein said gel pad (2) is substantially shaped like said sectional area.

[0045] The ultrasound device may be provided in a method for monitoring a human or animal body. The method for monitoring a human or animal body may comprise the steps of providing the ultrasound device, attaching the ultrasound device to said human or animal body, powering said ultrasound transducer to generate ultrasound waves, receiving reflected or scattered ultrasound waves, and calculating a graphical representation from said scattered ultrasound waves.

[0046] A method for treating a human or animal body may comprise the steps of providing the ultrasound device, attaching the ultrasound device to said human or animal body, and powering said ultrasound transducer to generate ultrasound waves to promote a healing process of said human or animal body tissue. The method may be used for treating and promoting healing of soft tissue.

[0047] While the invention has been described in terms of a single embodiment, those skilled in the art will recognize that the invention can be practiced with modification within the spirit and scope of the appended claims.

Having thus described my or any invention, what I claim as new and desire to secure by Letters Patent is as follows:

1. An ultrasound coupling device for transmitting ultrasound waves from an ultrasound transducer to a test specimen, especially to a human or animal body, said coupling device comprising

- (a) a gel pad (2) for transmitting said ultrasound waves,
- (b) a support (3) having
 - i) a transducer side (T),
 - ii) a body side (B), and
 - iii) an aperture (11) through said transducer side and said body side of said support (3),
- (c) said support (3) being provided with an adhesive element (13) on said body side, and
- (d) said gel pad (2) being received within said aperture (11) such that said gel pad (2) contacts said human or animal body when said body side of said support contacts said human or animal body.

2. The ultrasound coupling device according to claim 1, said gel pad (2) having an edge (10), said gel pad (2) being encircled by a frame (8) alongside the edge (10).

3. The ultrasound coupling device according to claim 2, said frame (10) comprising foam.

4. The ultrasound coupling device according to claim 3, said foam (10) being reticulated foam.

5. The ultrasound coupling device according to claim 1, said adhesive element (13) being capable of securely fixing said ultrasound coupling device (1) to said human or animal body.

6. The ultrasound coupling device according to claim 5, said support (3) comprising a liner (12) covering said adhesive element (13).

7. The ultrasound coupling device according to claim 5, said adhesive element comprising a pressure-sensitive film (13).

8. The ultrasound coupling device according to claim 1, said support (3) comprising a flat patch.

9. The ultrasound coupling device according to claim 8, said support (3) having a width (L_1), a length (L_2), and a

height (H), said width (L_1) or said length (L_2) being at least ten times larger than said height (H).

10. The ultrasound coupling device according to claim 1, said support (3) comprising a fixing area (A) on said transducer side (T), said fixing area (A) comprising a fastener (17) surrounding said aperture (11) for fixing said ultrasound transducer.

11. The ultrasound coupling device according to claim 10, said fixing area (15) completely surrounding said aperture (11).

12. The ultrasound coupling device according to claim 11, said fixing area (A) having a substantially constant width (w).

13. The ultrasound coupling device according to claim 10, said fastener comprising an adhesive (17) capable of adhesively fixing said ultrasound transducer.

14. The ultrasound coupling device according to claim 13, said adhesive (17) being located in cells of a foam.

15. The ultrasound coupling device according to claim 14, said adhesive (17) being located in cells of said frame (8).

16. The ultrasound coupling device according to claim 1, said aperture (11) being located close to a center of said support (3).

17. An ultrasound device for transmitting ultrasound waves from an ultrasound transducer to a human or animal body, said ultrasound device comprising:

- (a) an ultrasound coupling device (1) comprising:
 - (i) a gel pad (2) for transmitting said ultrasound waves,
 - (ii) a support (3) having a transducer side (T), a body side (B), and an aperture (11) through said transducer side and said body side of said support (3),
 - (iii) said support (3) being provided with an adhesive element (13) on said body side, and
 - (iv) said gel pad (2) being received within said aperture (11) such that said gel pad (2) contacts said human or animal body when said body side of said support contacts said human or animal body; and

(b) an ultrasound transducer, said ultrasound transducer comprising a cavity with an ultrasound transducer head, said cavity having a sectional area, wherein said gel pad (2) is substantially shaped like said sectional area.

18. The ultrasound device according to claim 17,

(a) said support comprising a fixing area (A) comprising a fastener (17) surrounding said aperture (11) for fixing said ultrasound transducer,

(b) said ultrasound device comprising an ultrasound transducer head, said cavity having a sectional area,

(c) said gel pad (2) being substantially shaped like said sectional area and

(d) said fixing area (A) being attached to a flange of said ultrasound transducer.

19. A method for monitoring a human or animal body comprising the steps of:

(a) providing an ultrasound device for transmitting ultrasound waves from an ultrasound transducer to a human or animal body, said ultrasound device comprising:

(i) an ultrasound coupling device (1) comprising:

- a gel pad (2) capable of transmitting ultrasound waves,

a support (3) having a transducer side (T), a body side (B), and an aperture (11) through said transducer side and said body side of said support (3), said support (3) being provided with an adhesive element (13) on said body side, and said gel pad (2) being received within said aperture (11) such that

said gel pad (2) contacts said human or animal body when said body side of said support contacts said human or animal body; and

- (ii) an ultrasound transducer, said ultrasound transducer comprising a cavity with an ultrasound transducer head, said cavity having a sectional area, wherein said gel pad (2) is substantially shaped like said sectional area
- (b) attaching the ultrasound device to said human or animal body,
- (c) powering said ultrasound transducer to generate ultrasound waves,
- (d) receiving reflected or scattered ultrasound waves, and
- (e) calculating a graphical representation from said scattered ultrasound waves.

20. A method for treating a human or animal body comprising the steps of:

- (a) providing an ultrasound device for transmitting ultrasound waves from an ultrasound transducer to a human or animal body, said ultrasound device comprising:
 - (i) an ultrasound coupling device (1) comprising:
 - a gel pad (2) capable of transmitting ultrasound waves,

a support (3) having a transducer side (T), a body side (B), and an aperture (11) through said transducer side and said body side of said support (3), said support (3) being provided with an adhesive element (13) on said body side, and said gel pad (2) being received within said aperture (11) such that said gel pad (2) contacts said human or animal body when said body side of said support contacts said human or animal body; and

- (ii) an ultrasound transducer, said ultrasound transducer comprising a cavity with an ultrasound transducer head, said cavity having a sectional area, wherein said gel pad (2) is substantially shaped like said sectional area;
- (b) attaching the ultrasound device to said human or animal body, and
- (c) powering said ultrasound transducer to generate ultrasound waves to promote a healing process of said human or animal body tissue.

21. The method according to claim 20, said human or animal body tissue being soft tissue.

* * * * *

专利名称(译)	超声耦合装置		
公开(公告)号	US20080200810A1	公开(公告)日	2008-08-21
申请号	US11/675977	申请日	2007-02-16
[标]申请(专利权)人(译)	BUCHALTER NEAL		
申请(专利权)人(译)	BUCHALTER NEAL		
当前申请(专利权)人(译)	BUCHALTER NEAL		
[标]发明人	BUCHALTER NEAL		
发明人	BUCHALTER, NEAL		
IPC分类号	A61B8/14		
CPC分类号	A61B8/4281 A61B8/4236		
其他公开文献	US8231533		
外部链接	Espacenet	USPTO	

摘要(译)

一种超声耦合装置，用于将超声波从超声换能器发射到测试样本，尤其是人体或动物体，所述耦合装置包括 (a) 用于发射所述超声波的凝胶垫 (2)，(b) 支撑物 (3) 具有 i) 换能器侧 (T)，ii) 主体侧 (B)，以及 iii) 穿过所述换能器侧和所述支撑件 (3) 的所述主体侧的孔 (11)，(c) 所述支撑件 (3) 在所述体侧设置有粘合元件 (13)，和 (d) 所述凝胶垫 (2) 容纳在所述孔 (11) 内，使得所述凝胶垫 (2) 在所述人体或动物体接触时所述支撑的身体侧接触人体或动物体。

