



US 20160243588A1

(19) **United States**

(12) **Patent Application Publication**
Nakanishi

(10) **Pub. No.: US 2016/0243588 A1**
(43) **Pub. Date: Aug. 25, 2016**

(54) **METHOD FOR MANUFACTURING CAPACITIVE MICROMACHINED ULTRASONIC TRANSDUCER AND APPARATUS CONFIGURED TO OBTAIN SUBJECT INFORMATION USING THE CAPACITIVE MICROMACHINED ULTRASONIC TRANSDUCER**

Publication Classification

(51) **Int. Cl.**
B06B 1/02 (2006.01)
B81C 1/00 (2006.01)
A61B 8/00 (2006.01)
B81B 7/00 (2006.01)
(52) **U.S. Cl.**
CPC *B06B 1/0292* (2013.01); *B81B 7/007* (2013.01); *B81C 1/00301* (2013.01); *A61B 8/4494* (2013.01)

(71) Applicant: **CANON KABUSHIKI KAISHA**,
Tokyo (JP)

(72) Inventor: **Koichiro Nakanishi**, Tokyo (JP)

(21) Appl. No.: **15/145,678**

(22) Filed: **May 3, 2016**

Related U.S. Application Data

(63) Continuation of application No. 13/682,640, filed on Nov. 20, 2012, now Pat. No. 9,352,960.

Foreign Application Priority Data

Nov. 28, 2011 (JP) 2011-259273

(57) **ABSTRACT**

There is provided a method for manufacturing a capacitive micromachined ultrasonic transducer. In this method, a first insulating layer and a vibrating membrane are bonded by heat treatment and a second insulating layer is formed by thermal oxidation in a single heating step, with a cavity provided in the transducer communicating with the outside of the transducer through a communication portion.

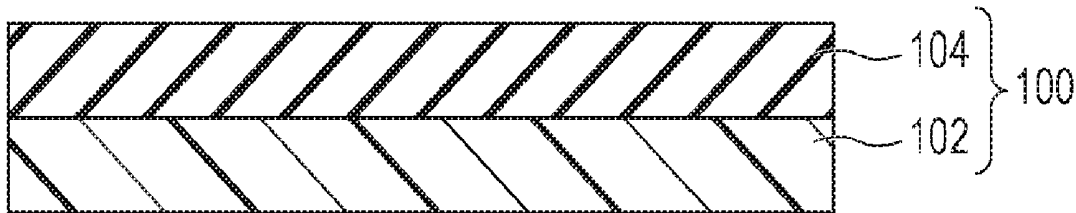

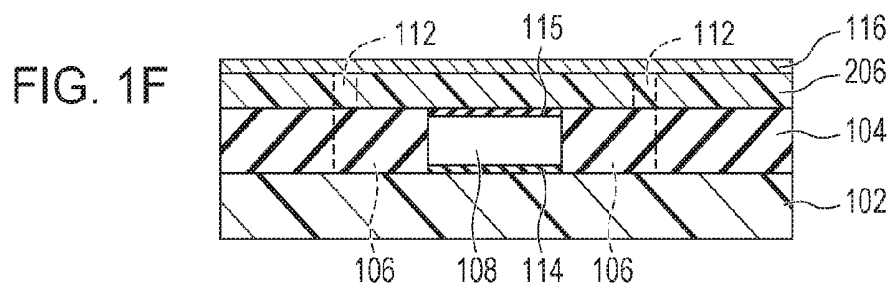
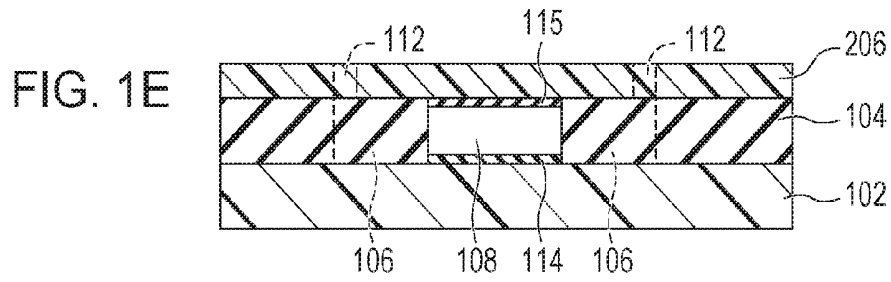
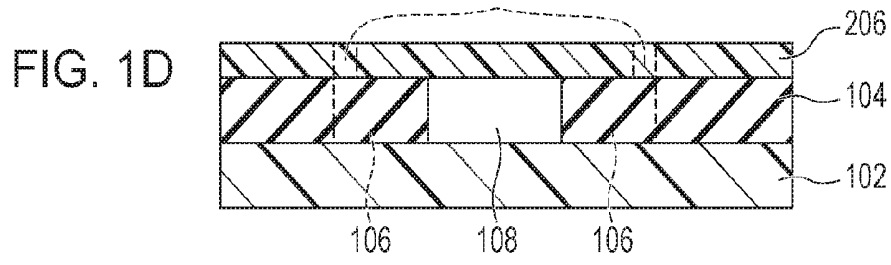
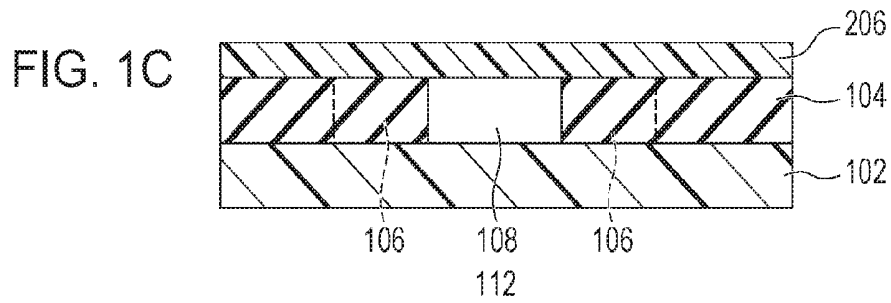
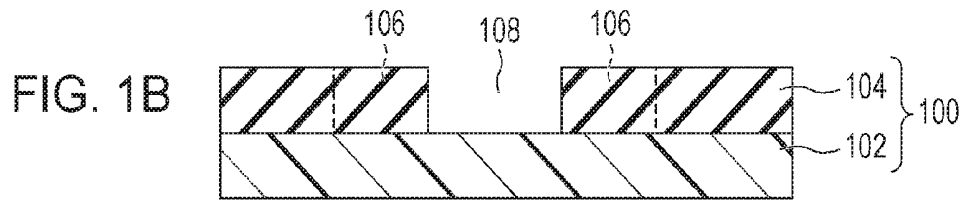
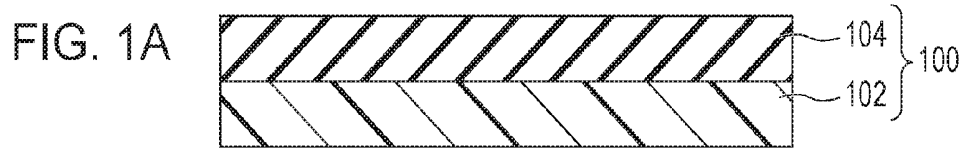

FIG. 2A

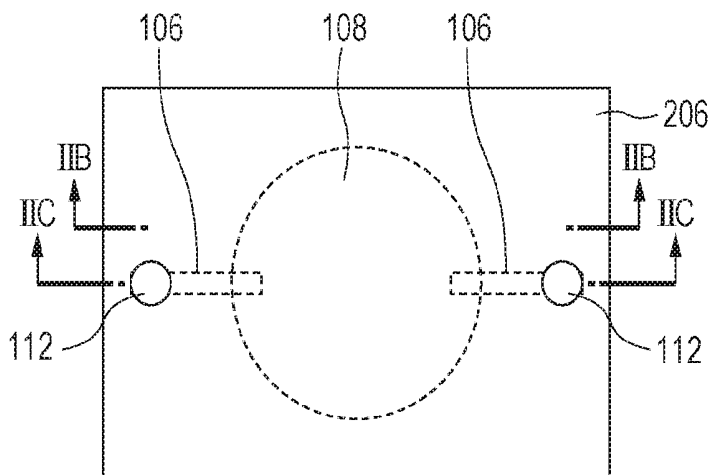

FIG. 2B

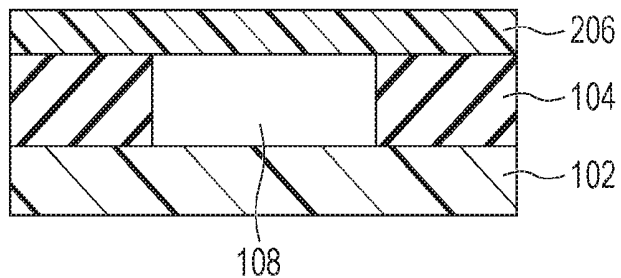

FIG. 2C

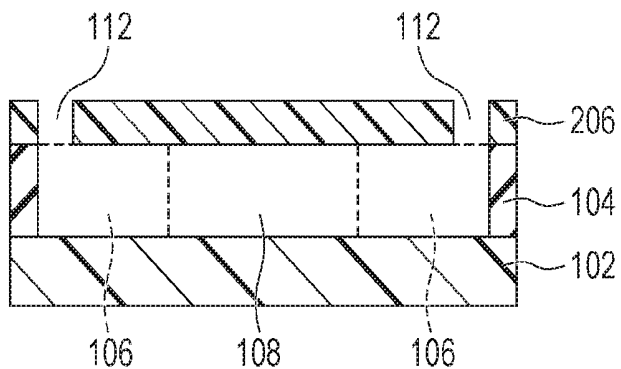

FIG. 3

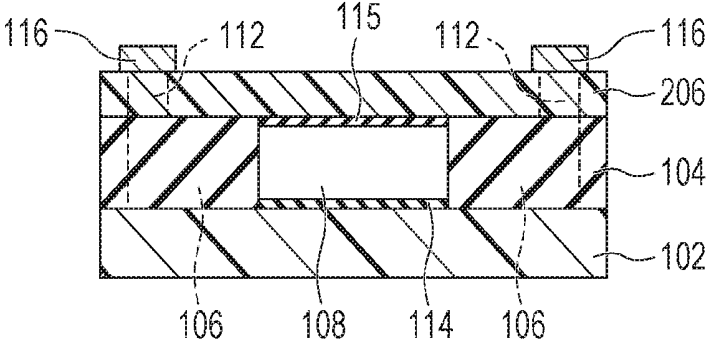

FIG. 4A

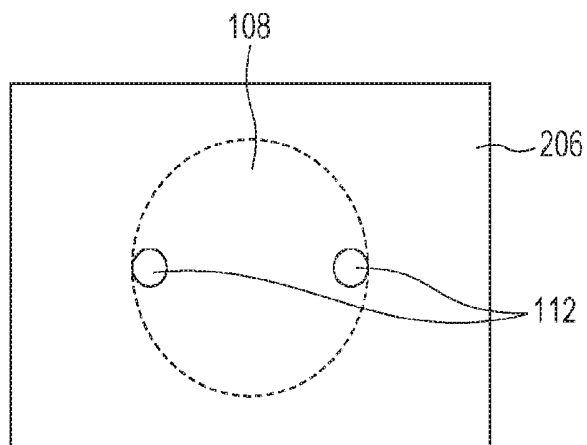

FIG. 4B

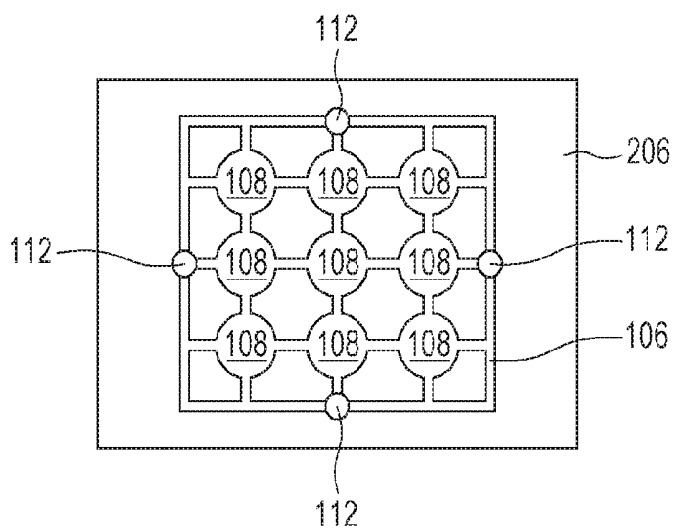
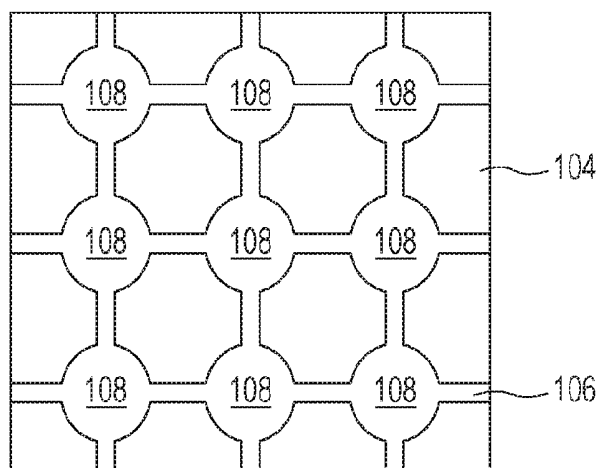
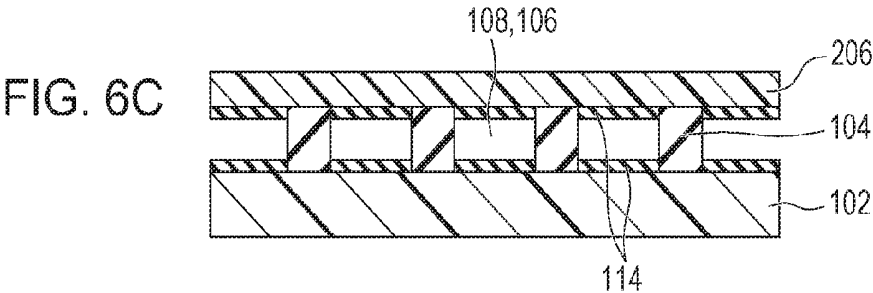
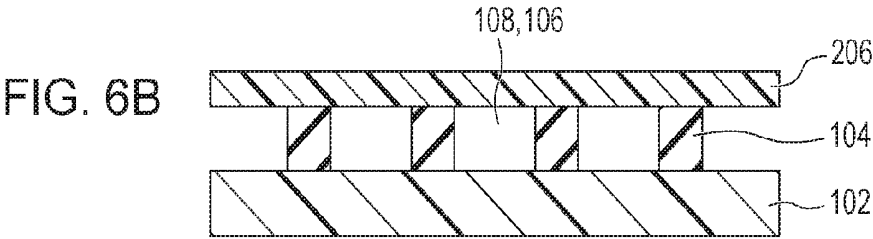
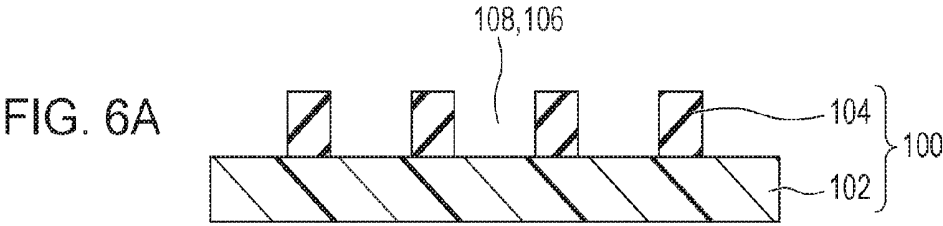

FIG. 5





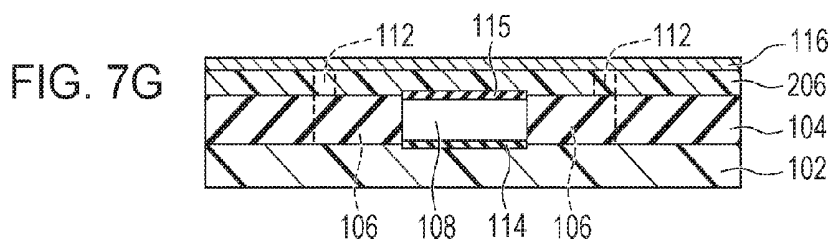
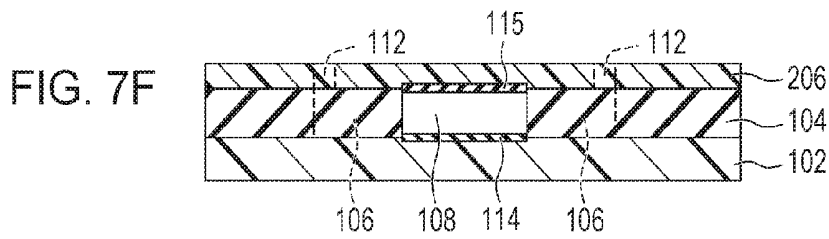
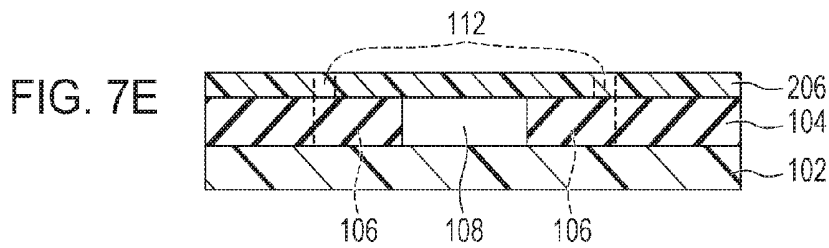
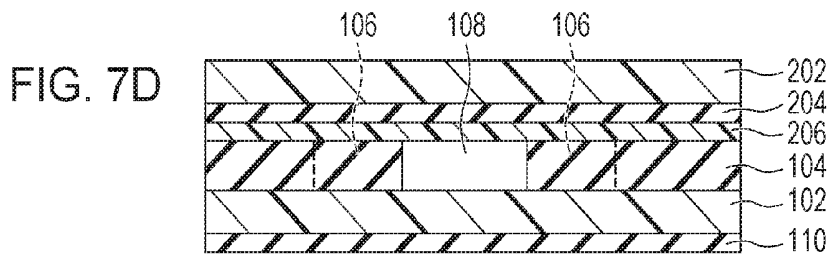
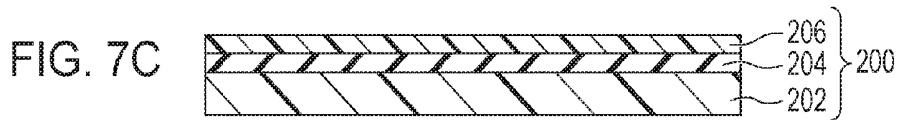
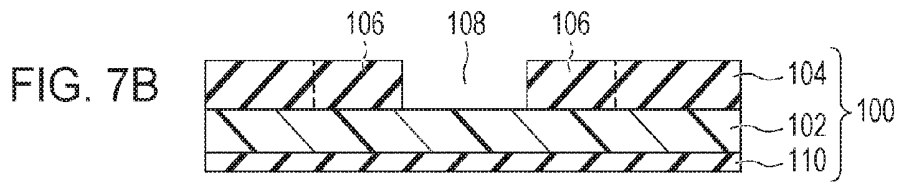
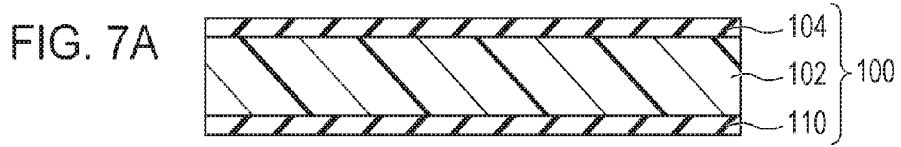

FIG. 8A

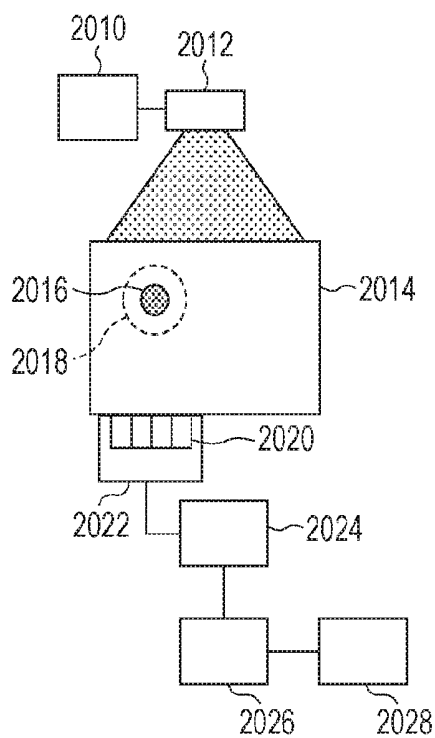
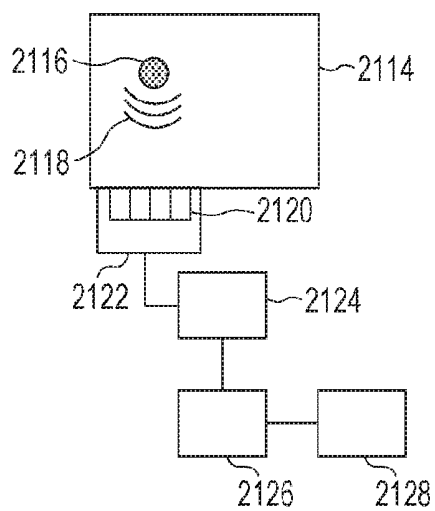
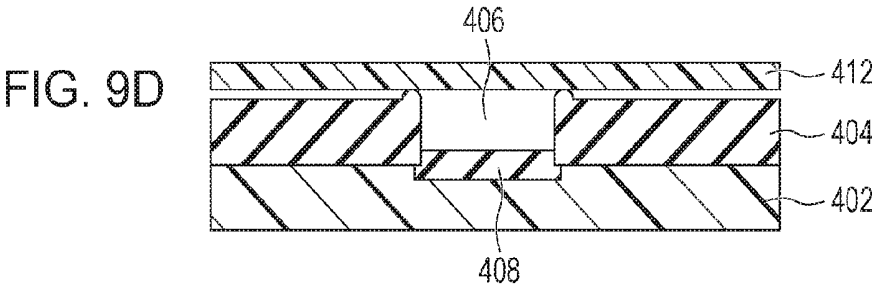
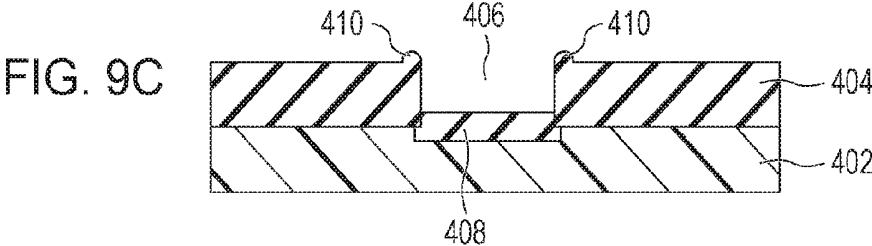
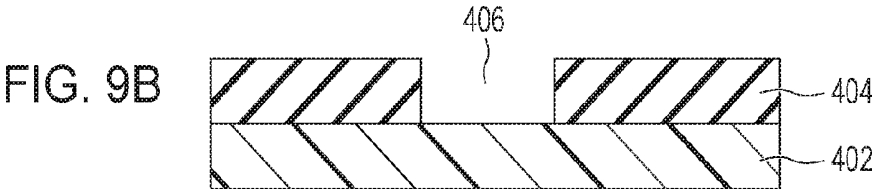

FIG. 8B





**METHOD FOR MANUFACTURING
CAPACITIVE MICROMACHINED
ULTRASONIC TRANSDUCER AND
APPARATUS CONFIGURED TO OBTAIN
SUBJECT INFORMATION USING THE
CAPACITIVE MICROMACHINED
ULTRASONIC TRANSDUCER**

CROSS REFERENCE TO RELATED
APPLICATIONS

[0001] The present application is a continuation of U.S. patent application Ser. No. 13/682,640, filed on Nov. 20, 2012, which claims priority from Japanese Patent Application No. 2011-259273, filed Nov. 28, 2011, all of which are hereby incorporated by reference herein in their entirety.

BACKGROUND OF THE INVENTION

[0002] 1. Field of the Invention

[0003] The present disclosure relates to a capacitive micromachined ultrasonic transducer that can be used in ultrasonic probes and other applications, and also to a method for manufacturing this capacitive micromachined ultrasonic transducer.

[0004] 2. Description of the Related Art

[0005] Ultrasonic diagnosis has recently been appreciated as a technology for early detection of diseases. In this field of diagnosis, one of the promising ultrasonic transmitting and receiving technologies under research is capacitive micromachined ultrasonic transducers (CMUTs), replacing piezoelectric elements. CMUTs are small and lightweight devices and are fabricated by the rapidly advancing micromachining technology. They have an acoustic impedance similar to that of the human body and thus offer better acoustic impedance matching than known piezoelectric devices. They are also advantageous in many other ways, for example, a broad frequency band in liquids.

[0006] PCT Japanese Translation Patent Publication No. 2006-516368 discloses a method for fabricating a CMUT, and this method involves the use of a single-crystal silicon vibrating membrane formed on a silicon substrate by bonding them or other suitable means. More specifically, an oxide film is formed on the silicon substrate by thermal oxidation, the resulting thermal oxide film is partially removed, and then the remaining portion of the thermal oxide film and a piece of single-crystal silicon are bonded. This piece of single-crystal silicon is used as the vibrating membrane, with the space formed by the partial removal of the thermal oxide film as a cavity.

[0007] The above patent publication mentions that the manufacturing method disclosed therein may include a second thermal oxidation step. After the removal of the thermal oxide film to expose a portion of the silicon substrate and thereby to form the cavity, the exposed surface of the silicon substrate is thermally oxidized again and thereby coated with an insulating oxide film.

SUMMARY OF THE INVENTION

[0008] Aspects of the present disclosure provide CMUTs with improved uniformity in device characteristics and a method for manufacturing such CMUTs.

[0009] In the manufacturing method according to an aspect disclosed herein, a first insulating layer and a vibrating membrane are bonded by heat treatment and a second insulating

layer is formed by thermal oxidation in a single heating step, with a cavity provided in the CMUT communicating with an outside of the CMUT through a communication portion.

[0010] As a result, there are provided CMUTs with improved uniformity in device characteristics and a method for manufacturing such CMUTs.

[0011] Further features of the present disclosure will become apparent from the following description of exemplary embodiments with reference to the attached drawings.

BRIEF DESCRIPTION OF THE DRAWINGS

[0012] FIGS. 1A to 1F illustrate a manufacturing process of a CMUT according to Embodiment 1.

[0013] FIGS. 2A to 2C are a plan view and cross-sectional views of the CMUT illustrated in FIG. 1D.

[0014] FIG. 3 illustrates a cross-section of another CMUT according to Embodiment 1.

[0015] FIGS. 4A and 4B are plan views of the other CMUT according to Embodiment 1.

[0016] FIG. 5 is a plan view of a first insulating layer configured in accordance with Embodiment 2.

[0017] FIGS. 6A to 6C illustrate a manufacturing process of a CMUT according to Embodiment 2.

[0018] FIGS. 7A to 7G illustrate the manufacturing process of the CMUT described later herein as Example 1.

[0019] FIGS. 8A and 8B illustrate the composition of apparatuses configured to obtain subject information (hereinafter also referred to as analyzers). These analyzers contain CMUTs as a necessary component and are described later herein as Example 2.

[0020] FIGS. 9A to 9D illustrate a known manufacturing process of a CMUT.

DESCRIPTION OF THE EMBODIMENTS

[0021] The method for manufacturing a CMUT described in PCT Japanese Translation Patent Publication No. 2006-516368 results in poor bonding between the thermal oxide film and single-crystal silicon because the second heating step causes protrusions of the thermal oxide film to form in the bonding interface, although this is not mentioned in the publication. The following describes this situation with reference to FIGS. 9A to 9D.

[0022] First, as illustrated in FIG. 9A, a silicon (Si) substrate 402 is thermally oxidized (a first heating step) and thereby a base 400 having a silicon oxide film 404 is prepared. Then, as illustrated in FIG. 9B, the silicon oxide film 404 is partially removed by etching and the Si substrate 402 is partially exposed, and thereby a cavity 406 is formed. The surface of the Si substrate 402 exposed to the cavity 406 is thermally oxidized (a second heating step) and thereby a silicon oxide film 408, which serves as an insulator, is formed on the exposed surface of the Si substrate 402. During this second heating step, silicon oxide also accumulates on the exposed bottom portions of the silicon oxide film 404 because these portions are near the cavity 406 and large amounts of oxygen are supplied there. As a result, protrusions 410 are formed on the top of the silicon oxide film 404 as illustrated in FIG. 9C. These protrusions 410 prevent a vibrating membrane 412 from coming into intimate contact as illustrated in FIG. 9D.

[0023] Although it is possible to ensure good bonding by removing the protrusions 410 from the interface, this may cause the silicon oxide film 404 to be partially removed

together with the protrusions 410. This affects the uniformity of the silicon oxide film 404 and causes the distribution of electric field intensity in the cavity 406 generated upon application of voltage to be uneven. This uneven distribution of electric field intensity leads to varying dielectric breakdown voltages of the resulting CMUT devices and thereby affects the reliability of them.

[0024] In light of this, embodiments of the present invention provide methods for manufacturing CMUTs with improved uniformity in device characteristics.

[0025] The following describes some embodiments of a method for manufacturing a CMUT according to an aspect of the present disclosure.

Embodiment 1

[0026] FIGS. 1A to 1F illustrate a manufacturing process of a CMUT according to this embodiment.

[0027] First, as illustrated in FIG. 1A, a silicon substrate 102 is coated with a first insulating layer 104, which is made of silicon oxide or similar materials, and thereby a base 100 is prepared. The first insulating layer 104 can be formed by thermal oxidation, chemical vapor deposition (CVD), or other suitable techniques. Thermal oxidation can ensure the characteristics of the resulting first insulating layer 104 such as thickness controllability, uniformity, film density, and adhesion to the silicon substrate 102.

[0028] Then, as illustrated in FIG. 1B, the first insulating layer 104 is partially removed and the silicon substrate 102 is partially exposed in a way that the first insulating layer 104 should have a pattern allowing it to support the vibrating membrane and a space that will later serve as a cavity 108 should be formed. A communication passage 106 may also be formed during this step that will later serve as a component of a communication portion that allows the cavity 108 to communicate with the outside.

[0029] The height of the space that will later serve as the cavity 108 determines the capacitance and thus should be precisely controlled. The technique used for the partial removal of the first insulating layer 104 should therefore be highly controllable. One example is wet etching with an etchant based on hydrofluoric acid, such as buffered hydrofluoric acid, and this can be used when the first insulating layer 104 is made of silicon oxide. Wet etching with buffered hydrofluoric acid or other hydrofluoric-acid-based etchants, which ensures that the selection ratio between silicon oxide and silicon is almost infinity, allows the height of the cavity 108 to be determined by the thickness of the silicon oxide layer. Reactive ion etching (RIE) and other dry etching techniques can also be used as long as adequate controllability is ensured.

[0030] The patterned first insulating layer 104 can also be obtained by using a mask layer so that the first insulating layer 104 can be formed having a predefined pattern. In this case, the mask layer is formed on the silicon substrate 102, the first insulating layer 104 is formed, and then the mask layer is removed, and the step illustrated in FIG. 1A is unnecessary.

[0031] Then, as illustrated in FIG. 1C, a vibrating membrane 206 and the first insulating layer 104 are bonded. The vibrating membrane 206 can be made of a lightweight material with a high Young's modulus, such as single-crystal silicon or silicon nitride. For example, silicon contained in the active layer of a silicon-on-insulator (SOI) substrate can be used for this purpose.

[0032] Fusion and other direct bonding techniques ensure sufficient strength of the junction. For example, the vibrating membrane 206 and the first insulating layer 104 can be bonded by overlaying the former on the latter and then heating them.

[0033] Then, as illustrated in FIG. 1D, communication holes 112 are formed through the vibrating membrane 206 to allow the cavity 108 to communicate with the outside of the transducer. This establishes a communication portion (the communication passage 106 and the communication holes 112) through which the cavity 108 is open to the outside of the CMUT. Although in this embodiment the communication holes 112 are formed through the vibrating membrane 206, the communication holes 112 may be formed through the silicon substrate 102 instead. Furthermore, although in this embodiment the vibrating membrane 206 and the first insulating layer 104 are bonded first and then the communication holes 112 are formed, it is also allowed to form the communication holes 112 through the vibrating membrane 206 first and then bond the vibrating membrane 206 and the first insulating layer 104.

[0034] FIG. 2A is a plan view of the CMUT illustrated in FIG. 1D, and FIGS. 2B and 2C are cross-sectional views of the CMUT illustrated in FIG. 2A taken along lines IIB-IIB and IIC-IIC, respectively. As can be seen from FIG. 2C, the cavity 108 can communicate with the outside of the CMUT through the communication portion (the communication passage 106 and the communication holes 112).

[0035] Then, the material(s) for a second insulating layer 114 is introduced in a gaseous form through the communication portion (the communication passage 106 and the communication holes 112), and the second insulating layer 114 is formed in an atmosphere containing the gas in a way that the surface of the silicon substrate 102 exposed to the cavity 108 should be coated as illustrated in FIG. 1E. The second insulating layer 114 can be formed by thermal oxidation, CVD, or other suitable techniques. The formation of the second insulating layer 114 by thermal oxidation includes introduction of oxygen through the communication portion and subsequent heating in the oxygen-containing atmosphere and thus ensures that silicon oxide is incorporated in the resulting insulating layer. CVD allows the second insulating layer 114 to be formed of materials such as silicon nitride. In the case of silicon nitride, the gas introduced as a silicon source can be SiH_4 , SiH_2Cl_2 , or the like, and the gas introduced as a nitrogen source can be N_2 , NH_3 , or the like.

[0036] When the vibrating membrane 206 is made of silicon and thermal oxidation is chosen or when CVD is chosen, another second insulating layer 115 is formed on the surface of the vibrating membrane 206 exposed to the cavity 108. Forming two second insulating layers 114 and 115 on the silicon substrate 102 and the vibrating membrane 206 to coat their surfaces exposed to the cavity 108 in this way can lead to improved insulation between the silicon substrate 102 and the vibrating membrane 206.

[0037] After that, the communication between the cavity 108 and outside the transducer can be blocked; this allows the transducer to be used in liquid or under similar conditions. For example, it is allowed to form a blocking layer 106 configured to seal the communication holes 112 as illustrated in FIG. 1F. The blocking layer 116, if it is used, can be formed from materials such as silicon nitride by CVD or other suitable techniques. In addition to blocking the communication, the blocking layer 116 can be used to modify the mechanical

properties of the vibrating membrane 206 as its thickness, stress properties, and other relevant physical characteristics can be appropriately adjusted. It is also allowed to form a blocking layer 116 only to cover the communication holes 112 as illustrated in FIG. 3.

[0038] When the vibrating membrane 206 is made of silicon, the communication holes 112 can also be closed by forming an insulating layer on the vibrating membrane 206 to seal the communication holes 112 in parallel with the formation of the second insulating layer 114 in one thermal oxidation step. In this case, the temperature, time, and other conditions of thermal oxidation and the size of the communication holes 112 are selected so as to ensure that the second insulating layer 114 reaches a sufficient thickness before the communication holes 112 are closed.

[0039] After the vibrating membrane 206 is placed on the first insulating layer 104, it is allowed to bond the vibrating membrane 206 and the first insulating layer 104 by heat treatment and form the second insulating layer 114 by thermal oxidation in one heating step. A possible way to do this is as follows: the laminate of the first insulating layer 104 and the vibrating layer 206 is heated in a nitrogen-containing atmosphere at 1050° C. for 3 hours and in an oxygen-containing atmosphere at 1050° C. for additional 1 hour. Completing heat bonding and thermal oxidation in one heating step in this way can lead to a simplified manufacturing process of a CMUT with a reduced number of operations.

[0040] Completing heat bonding and thermal oxidation in one heating step can also lead to reduced thermal hysteresis of the resulting CMUT. In general, devices with small hysteresis are highly reliable. Completing heat bonding and thermal oxidation in one heating step therefore means improving the manufacturing yield of CMUTs.

[0041] Importantly, the communication portion should be open during this heating step for simultaneous heat bonding and thermal oxidation so that the cavity 108 can communicate with the outside of the CMUT.

[0042] As illustrated in FIG. 4A, the communication holes 112 may be formed in the portion of the vibrating membrane 206 located above the cavity 108. This arrangement eliminates the need to form the communication passage 106 because the cavity 108 serves as the communication passage 106. In this case, only the communication holes 112 are regarded as the communication portion.

[0043] Furthermore, as illustrated in FIG. 4B, it is allowed to form several cavities 108 linked with several communication passages 106. This arrangement leads to a smaller number of communication holes 112 required than is necessary when the cavities 108 are isolated.

[0044] In this way, this manufacturing method makes it possible to produce CMUTs with highly uniform device characteristics.

Embodiment 2

[0045] FIG. 5 is a plan view of a patterned first insulating layer 104 configured in accordance with this embodiment. The difference between this embodiment and Embodiment 1 is that in this embodiment no communication holes are formed and the communication portion consists only of communication passages 106 formed during the patterning of the first insulating layer 104. Each communication passage 106 extends from one lateral side of the CMUT to the other side through some cavities 108, allowing the cavities 108 to communicate with the outside of the CMUT.

[0046] FIGS. 6A to 6C illustrate a manufacturing process of a CMUT according to this embodiment.

[0047] First, as illustrated in FIG. 6A, a patterned first insulating layer 104 is formed on a silicon substrate 102. The first insulating layer 104 is patterned in a way that the pattern will later provide the communication passages 106 that ensure communication between the cavities 108 and outside the CMUT. A possible approach to the patterning of the first insulating layer 104 in this way is to form the first insulating layer 104 by thermal oxidation, CVD, or other suitable techniques followed by etching. In another possible approach, the first insulating layer 104 is formed using a mask layer prepared in advance, and then the mask layer is removed.

[0048] Then, as illustrated in FIG. 6B, a vibrating membrane 206 and the first insulating layer 104 are bonded.

[0049] Through the thus-formed communication portion (the communication passages 106), the material(s) for second insulating layers 114 is introduced in a gaseous form. The second insulating layers 114 are formed in an atmosphere containing the gas in a way that the surfaces exposed to the cavities 108 should be coated as illustrated in FIG. 6C. The second insulating layers 114 can be formed by thermal oxidation, CVD, or other suitable techniques.

[0050] After that, the communication between the cavity 108 and outside the transducer can be blocked so that the transducer can be used in liquid or under similar conditions.

[0051] In this way, this manufacturing method makes it possible to produce CMUTs with highly uniform device characteristics.

[0052] Furthermore, the manufacturing method according to this embodiment, in which no communication holes are formed and the communication portion consists only of communication passages 106 formed during the patterning of the first insulating layer 104, includes a smaller number of operations and is simpler than that according to Embodiment 1.

[0053] Forming communication holes as a component of the communication portion through the vibrating membrane 206 as in Embodiment 1 may also cause damage to the vibrating membrane 206. Damage to the vibrating membrane 206 may affect the characteristics of the resulting CMUT.

[0054] The method according to this embodiment, however, by which the communication portion can be formed without making communication holes in the vibrating membrane 206, poses reduction of risk for damage to the vibrating membrane 206 associated with the formation of the communication portion.

Example 1

[0055] The following describes Example 1 of an aspect of the present disclosure with reference to FIGS. 7A to 7G.

[0056] First, as illustrated in FIG. 7A, a silicon oxide film 104 is formed on a silicon substrate 102 and thereby a base 100 is prepared. The silicon substrate 102 has a thickness of 300 μm, and its resistance is low (specific resistance $\leq 0.02 \Omega\text{-cm}$) so that it can be used as the lower electrode. This silicon substrate 102 is thermally oxidized at 1100° C. and thereby the silicon oxide film 104 is formed with a thickness of 200 nm. By this operation, the surface of the silicon substrate 102 opposite to the silicon oxide film 104 is also coated with a silicon oxide film 110.

[0057] Then, a resist pattern is formed on the silicon oxide film 104. This resist pattern will later provide a cavity 108 and a communication passage 106 that allows the cavity 108 to communicate with the outside of the transducer. The silicon

oxide film **104** is then partially removed by etching with buffered hydrofluoric acid and the silicon substrate **102** is partially exposed in a way that the portions corresponding to the cavity **108** and the communication passage **106** are etched away. After removing the resist pattern, the silicon oxide film **104** is patterned as illustrated in FIG. 7B, with the silicon oxide film **110** covered with a resist so as not to be etched.

[0058] Separately, as illustrated in FIG. 7C, another silicon substrate **202** is coated with a silicon oxide layer **204** and then with a silicon film **206** and thereby a SOI base **200** is prepared. The silicon substrate **202** is a 725- μm thick handle layer, the silicon oxide layer **204** is a 400-nm thick buried oxide (BOX) layer, and the silicon film **206** is a 1- μm thick active layer.

[0059] Then, as illustrated in FIG. 7D, the silicon film **206** of the SOI base **200** is bonded to the silicon oxide film **104** of the base **100**, which has the cavity **108** and the communication passage **106** formed thereon. More specifically, the base **100** and the SOI base **200** are thoroughly washed with sulfuric acid, hydrogen peroxide, hydrochloric acid, and ultrapure water so that their surfaces should be made hydrophilic, and the laminate obtained by simply placing one on the other is heated at 1000° C. for 4 hours. After the completion of this heat bonding step at 1000° C., the silicon handle layer **202** and the silicon oxide BOX layer **204** need to be removed so that the silicon film **206** of the SOI base **200** can be used as the vibrating membrane.

[0060] The first step is to make the silicon handle layer **202** as thin as 50 μm by backgrinding. The remaining portion of the silicon handle layer **202** is then removed by etching with a solution of tetramethylammonium hydroxide, with the silicon oxide BOX layer **204** as the etching stop layer and with the silicon oxide film **110** as the etching mask layer for the silicon substrate **102**. Subsequently, the silicon oxide BOX layer **204** is removed by etching with buffered hydrofluoric acid. During this operation to remove the silicon oxide BOX layer **204** by etching, the silicon active layer **206** serves as the etching stop layer. The silicon oxide film **110** is also etched away by this operation.

[0061] The silicon active layer **206**, which will later serve as a vibrating membrane, is exposed in this way. Then, as illustrated in FIG. 7E, communication holes **112** are formed in a way that the cavity **108** can communicate with the outside of the transducer. The communication holes **112** are 6- μm diameter holes formed by patterning using a photoresist and subsequent RIE with a tetrafluoromethane gas and extend through to the communication passage **106**.

[0062] After removing the unnecessary portion of the photoresist, the entire structure is washed, placed into a thermal oxidation furnace, and thermally oxidized in an oxygen atmosphere at 1000° C. for 2 hours. As a result, the surface of the silicon substrate **102** exposed to the cavity **108** is coated with a thermal oxide film **114** having a thickness of 50 nm as illustrated in FIG. 7F. By this operation, the exposed inner surface of the silicon film **206** is also coated with a silicon oxide layer **115** of a similar thickness.

[0063] Then, as illustrated in FIG. 7G, a silicon nitride film **116** is formed on the silicon film **206** by plasma CVD with a thickness of 700 nm to seal the communication holes **112** and to isolate the cavity **108** from outside the transducer.

Example 2

[0064] The CMUT described in the above example can be applied to apparatuses configured to obtain subject information by means of acoustic waves (hereinafter referred to as

acoustic wave analyzers). The acoustic wave analyzer uses CMUTs to receive acoustic waves from a subject and converts the electric signals generated by the CMUTs into pieces of information that indicate the coefficient of optical absorption and other optical properties of the subject, the distribution of acoustic impedance in the subject, and so forth.

[0065] FIG. 8A illustrates the composition of an analyzer that operates on the photoacoustic effect. A light source **2010** generates light pulses, and these light pulses travel through an optical member **2012** composed of lenses, mirrors, fiber optics, and other components and illuminate a subject **2014**. The light-absorbing material **2016** existing in the subject **2014** absorbs the energy of the light pulses and emits photoacoustic waves **2018** that behave as acoustic waves. A probe composed of CMUTs **2020** and a housing **2022** receives the photoacoustic waves **2018**, transforms them into electric signals, and sends the signals to a signal processor **2024**. After processing by the signal processor **2024** including analog-to-digital (A/D) conversion, amplification, and so forth, the electric signals are transmitted to a data processor **2026**. The data processor **2026** processes the signals and collects pieces of information about the subject (those indicating the coefficient of optical absorption and other optical properties) in the form of image data. In this example, the signal processor **2024** and the data processor **2026** together operate as a processing unit. A display unit **2028** creates an image from the image data provided by the data processor **2026** and shows the image.

[0066] FIG. 8B illustrates the composition of an analyzer that analyzes subjects by means of reflected acoustic waves, e.g., an ultrasonic diagnosis system.

[0067] A probe composed of CMUTs **2120** and a housing **2122** emits acoustic waves into a subject **2114**, and a portion of the acoustic waves is reflected by a reflective material **2116**. The probe in turn receives the reflected acoustic waves **2118** (reflected waves), transforms them into electric signals, and sends the signals to a signal processor **2124**. After processing by the signal processor **2124** including A/D conversion, amplification, and so forth, the electric signals are transmitted to a data processor **2126**. The data processor **2126** processes the signals and collects pieces of information about the subject (those indicating the distribution of acoustic impedance in the subject) in the form of image data. In this example, the signal processor **2124** and the data processor **2126** together operate as a processing unit. A display unit **2128** creates an image from the image data provided by the data processor **2126** and shows the image.

[0068] For both the analyzers illustrated in FIGS. 8A and 8B, the probe may be a scanning unit of mechanical equipment or a hand-held scanner that can be moved manually by the user (a physician, a technician, or the like) on or above the subject. In cases where reflected waves are utilized as in FIG. 8B, the analyzer may incorporate two separate components that serve as an emitter of acoustic waves and a receiver of reflected waves instead of the probe.

[0069] While the present invention has been described with reference to exemplary embodiments, it is to be understood that the invention is not limited to the disclosed exemplary embodiments. The scope of the following claims is to be accorded the broadest interpretation so as to encompass all such modifications and equivalent structures and functions.

What is claimed is:

1. A method for manufacturing a capacitive micromachined ultrasonic transducer having a vibrating membrane, a substrate, and a vibrating-membrane-supporting member

configured to support the vibrating membrane to form a cavity between the substrate and the vibrating membrane, comprising steps of:

- forming a first insulating layer on either side of the substrate, the first insulating layer patterned to serve as the vibrating-membrane-supporting member;
 - overlaying the vibrating membrane on the patterned first insulating layer;
 - bonding the first insulating layer and the vibrating membrane by heat treatment after overlaying the vibrating membrane on the patterned first insulating layer; and
 - forming a second insulating layer on a surface of the substrate or the vibrating membrane exposed to the cavity by introducing a gas into the cavity through a communication portion that allows the cavity to communicate with an outside of the capacitive micromachined ultrasonic transducer and subsequent thermal oxidation in an atmosphere containing the gas, after overlaying the vibrating membrane on the patterned first insulating layer, wherein
 - with the cavity communicating with the outside of the capacitive micromachined ultrasonic transducer through the communication portion, the first insulating layer and the vibrating membrane are bonded by heat treatment and the second insulating layer is formed by thermal oxidation in a single heating step.
2. The method for manufacturing a capacitive micromachined ultrasonic transducer according to claim 1, wherein the patterned first insulating layer is formed together with a communication passage and configured to serve as a component of the communication portion.
 3. The method for manufacturing a capacitive micromachined ultrasonic transducer according to claim 2, wherein the communication portion consists only of the communication passage.
 4. The method for manufacturing a capacitive micromachined ultrasonic transducer according to claim 1, further comprising a step of:
 - providing the substrate or the vibrating membrane with a communication hole configured to function as a component of the communication portion.

5. The method for manufacturing a capacitive micromachined ultrasonic transducer according to claim 1, further comprising a step of:
 - forming a blocking layer configured to prevent the cavity from communicating with the outside of the capacitive micromachined ultrasonic transducer after forming the second insulating layer.

6. The method for manufacturing a capacitive micromachined ultrasonic transducer according to claim 1, wherein the substrate is a silicon-containing substrate, and the second insulating layer contains a silicon-oxide-containing layer formed by thermal oxidation of the silicon-containing substrate.

7. The method for manufacturing a capacitive micromachined ultrasonic transducer according to claim 1, wherein the vibrating membrane is a silicon-containing film, and the second insulating layer contains a silicon-oxide-containing layer formed by thermal oxidation of the silicon-containing film.

8. The method for manufacturing a capacitive micromachined ultrasonic transducer according to claim 1, wherein the patterned first insulating layer is formed by forming the first insulating layer on either side of the substrate by thermal oxidation in an atmosphere containing oxygen and subsequent etching on the first insulating layer.

9. An apparatus configured to obtain subject information, comprising:
 - a capacitive micromachined ultrasonic transducer produced by the method for manufacturing a capacitive micromachined ultrasonic transducer according to claim 1, and
 - a processing unit configured to obtain subject information using an electric signal output from the capacitive micromachined ultrasonic transducer, wherein
 - the capacitive micromachined ultrasonic transducer receives an acoustic wave from the subject and transduces the acoustic wave into the electric signal.

* * * * *

专利名称(译)	用于制造电容微机械超声换能器的方法和被配置为使用电容微机械超声换能器获得对象信息的装置		
公开(公告)号	US20160243588A1	公开(公告)日	2016-08-25
申请号	US15/145678	申请日	2016-05-03
[标]申请(专利权)人(译)	佳能株式会社		
申请(专利权)人(译)	佳能株式会社		
当前申请(专利权)人(译)	佳能株式会社		
[标]发明人	NAKANISHI KOICHIRO		
发明人	NAKANISHI, KOICHIRO		
IPC分类号	B06B1/02 B81C1/00 A61B8/00 B81B7/00		
CPC分类号	B81C1/00269 B81B3/0027 G01N29/2406 B06B1/0292 B81B7/007 B81C1/00301 A61B8/4494		
优先权	2011259273 2011-11-28 JP		
外部链接	Espacenet USPTO		

摘要(译)

提供了一种用于制造电容微机械超声换能器的方法。在该方法中，通过热处理接合第一绝缘层和振动膜，并且在单个加热步骤中通过热氧化形成第二绝缘层，其中设置在换能器中的腔通过通信与换能器的外部连通。一部分。

