



US 20050143658A1

(19) **United States**

(12) **Patent Application Publication**
Saiga

(10) **Pub. No.: US 2005/0143658 A1**

(43) **Pub. Date: Jun. 30, 2005**

(54) **ULTRASONIC ENDOSCOPE AND
ULTRASONIC SIGNAL CABLE CONNECTOR
DEVICE**

(52) **U.S. Cl. 600/462**

(75) **Inventor: Kazuya Saiga, Tokyo (JP)**

(57) **ABSTRACT**

Correspondence Address:
SCULLY SCOTT MURPHY & PRESSER, PC
400 GARDEN CITY PLAZA
SUITE 300
GARDEN CITY, NY 11530 (US)

An ultrasonic signal cable connector device, used with an ultrasonic endoscope device comprising an ultrasonic endoscope having an electronic scanning ultrasonic transducer and ultrasonic measuring equipment, comprises: an ultrasonic signal cable having signal lines connected to the electronic scanning ultrasonic transducer; an ultrasonic connector for connecting the ultrasonic signal cable to the ultrasonic measuring equipment; a rectangular wiring board of approximately the same or smaller width as the external diameter of the ultrasonic signal cable; signal line connecting lands arrayed in parallel on the surface of one of the short sides of the wiring board for electrically connecting the signal lines of the ultrasonic signal cable; contact piece lands arrayed in a column longitudinally on the surface of the wiring board for electrically connecting connector pieces of the ultrasonic connector; and wiring patterns for connecting the signal line connecting lands and contact piece lands on the surface of the wiring board.

(73) **Assignee: Olympus Corporation, Tokyo (JP)**

(21) **Appl. No.: 11/018,248**

(22) **Filed: Dec. 21, 2004**

(30) **Foreign Application Priority Data**

Dec. 26, 2003 (JP) 2003-435623

Publication Classification

(51) **Int. Cl.⁷ A61B 8/14**

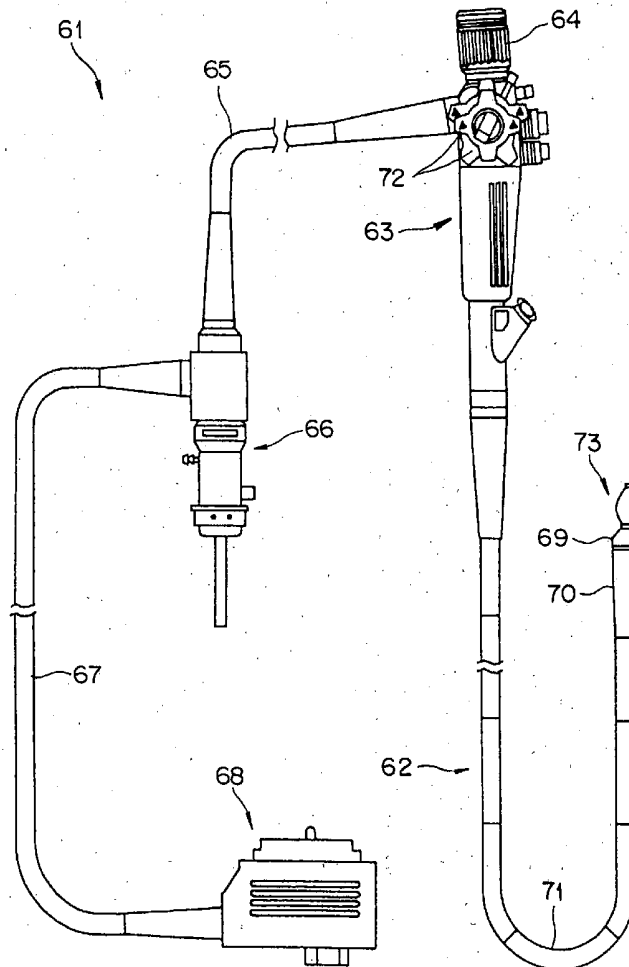

FIG. 1

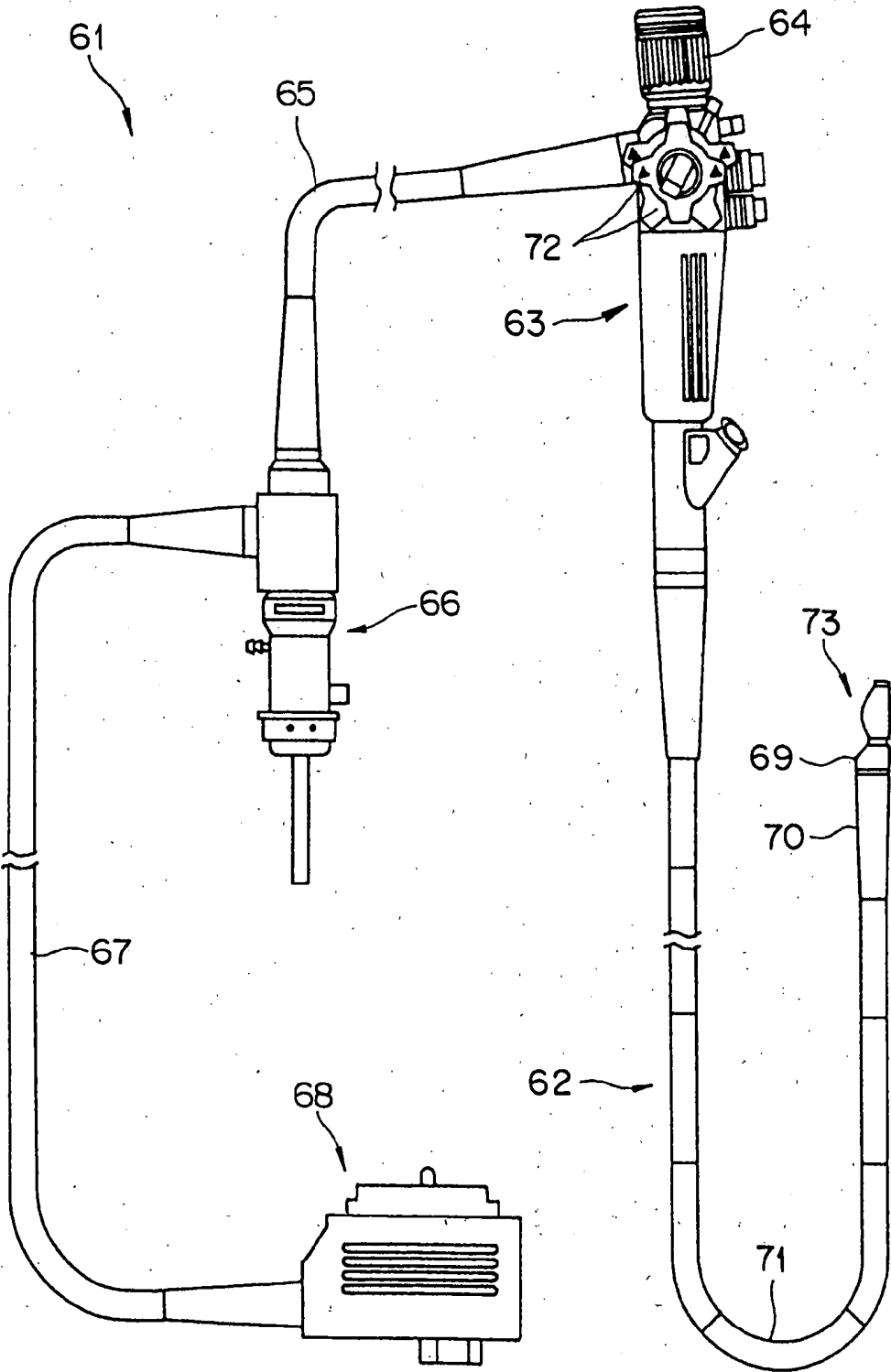

FIG.2

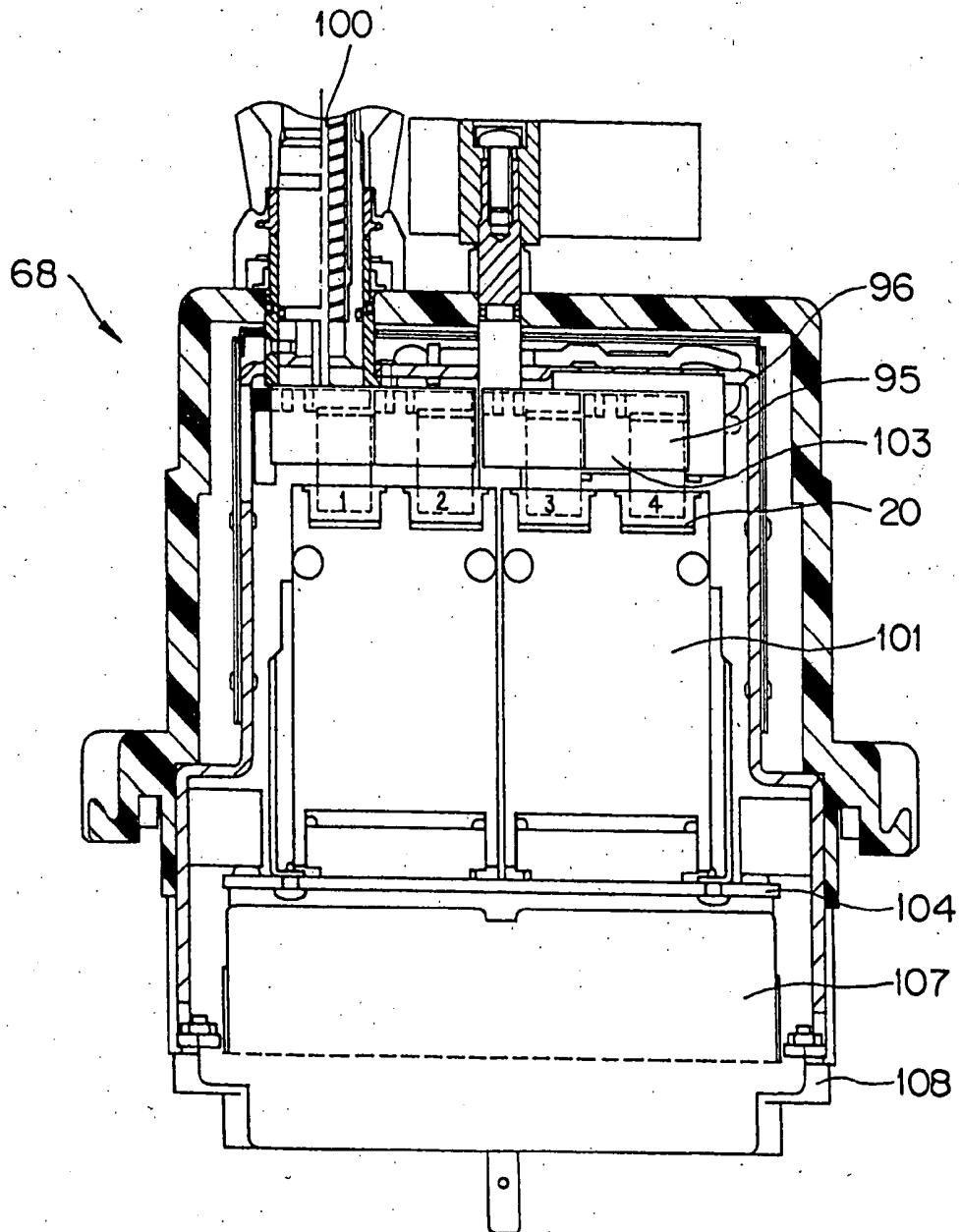

FIG. 3

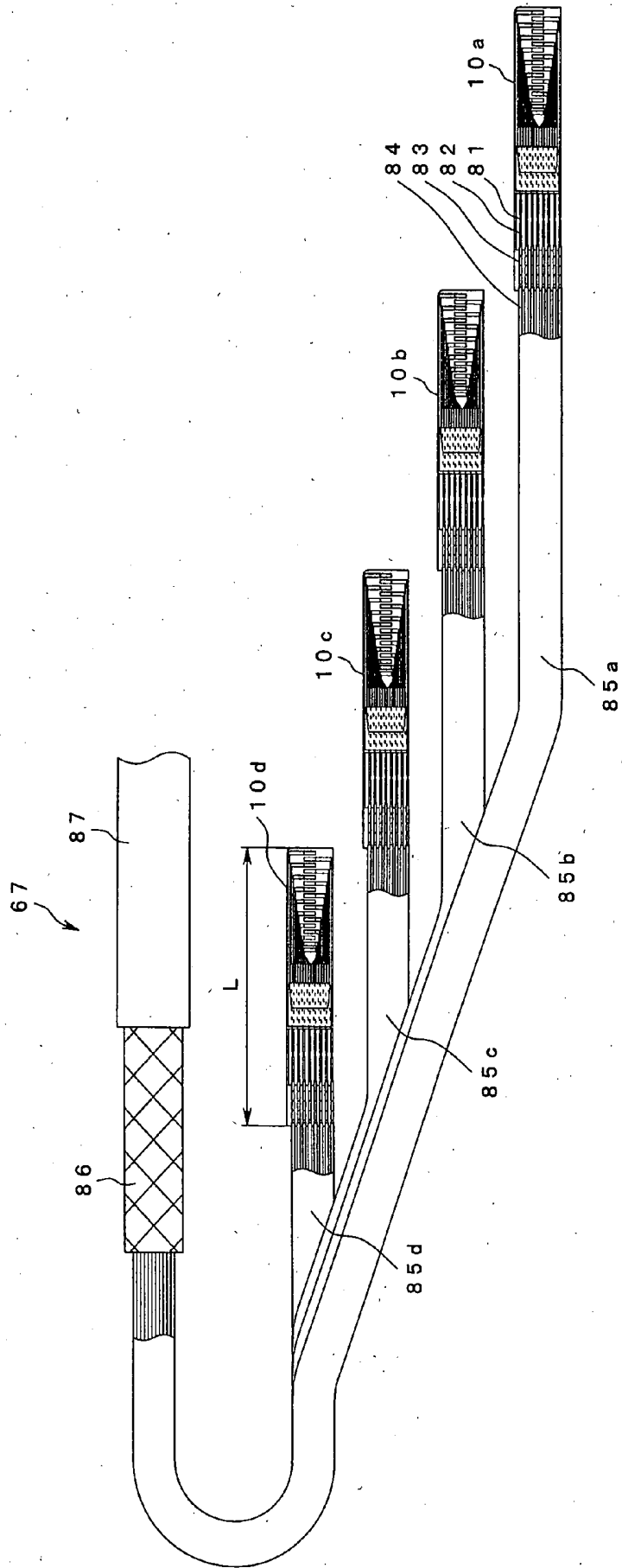

FIG.4

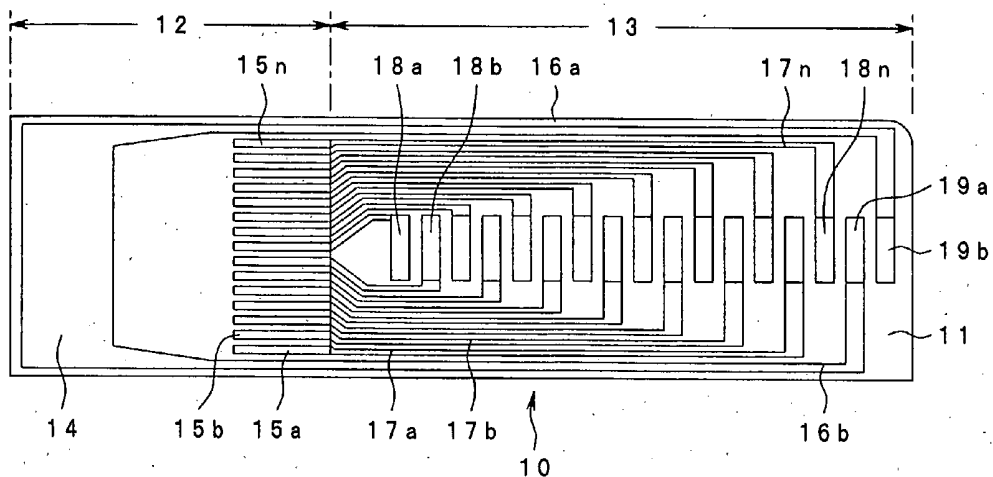

FIG.5

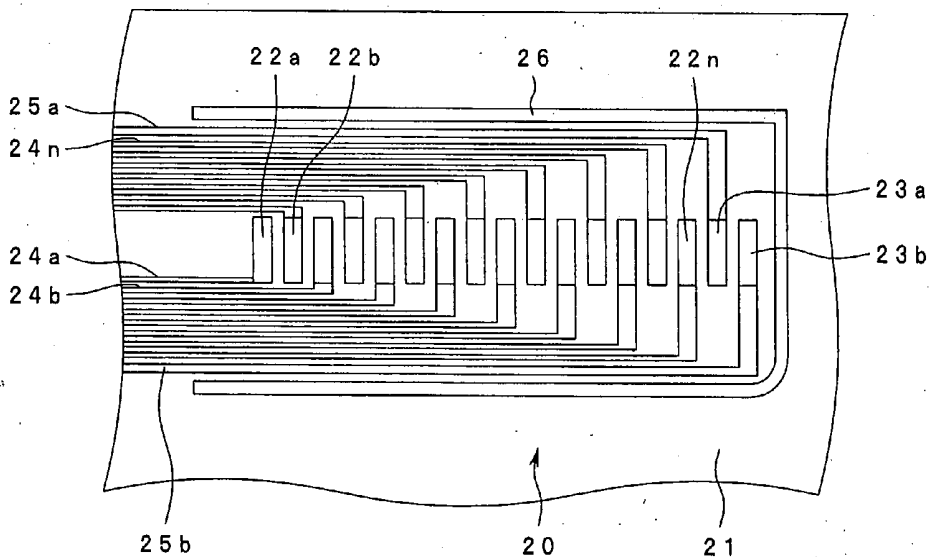

FIG. 6

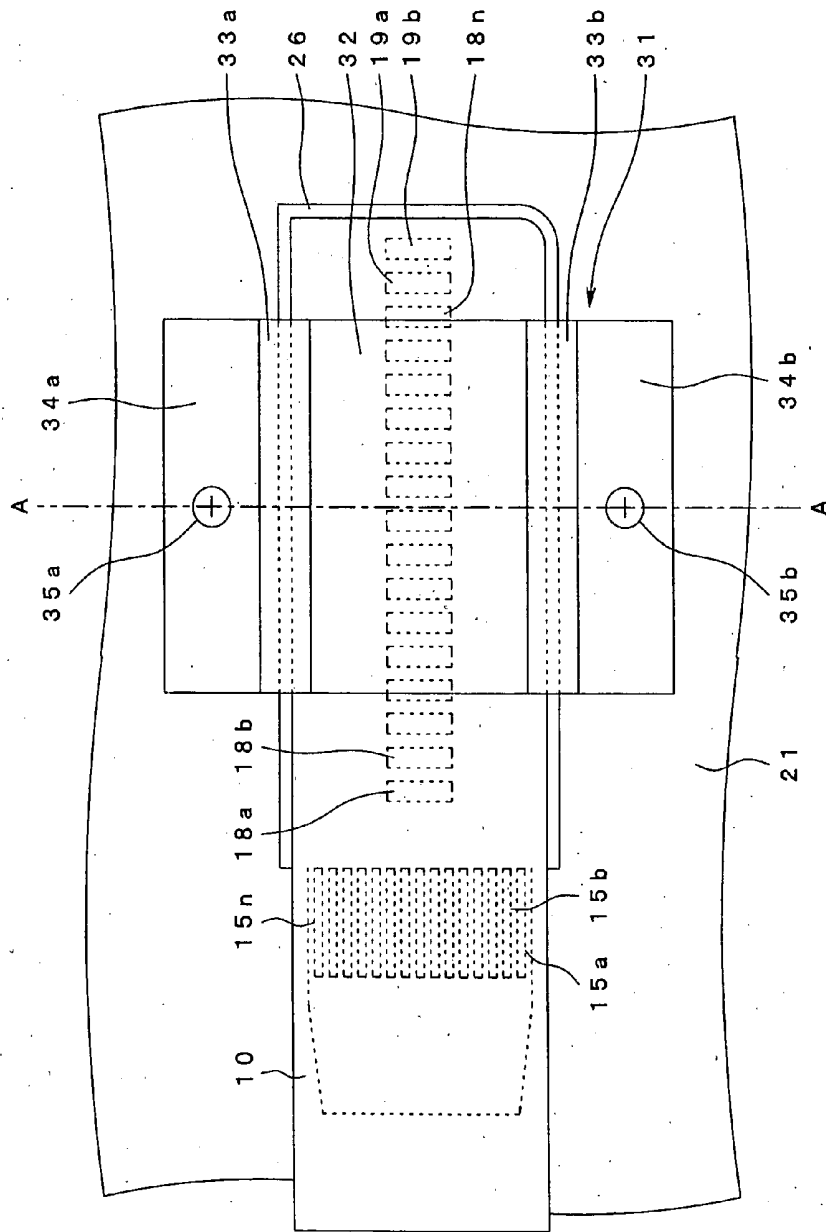

FIG. 7

A-A

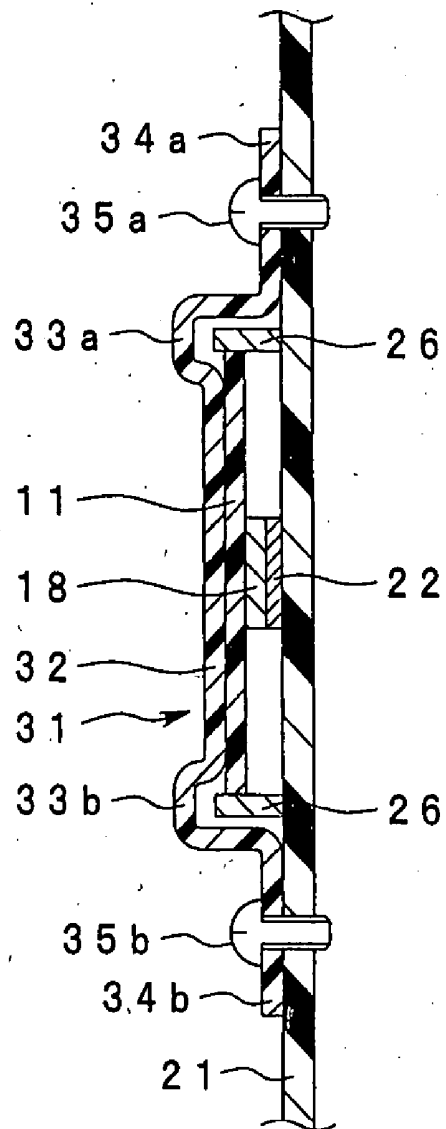

FIG. 8

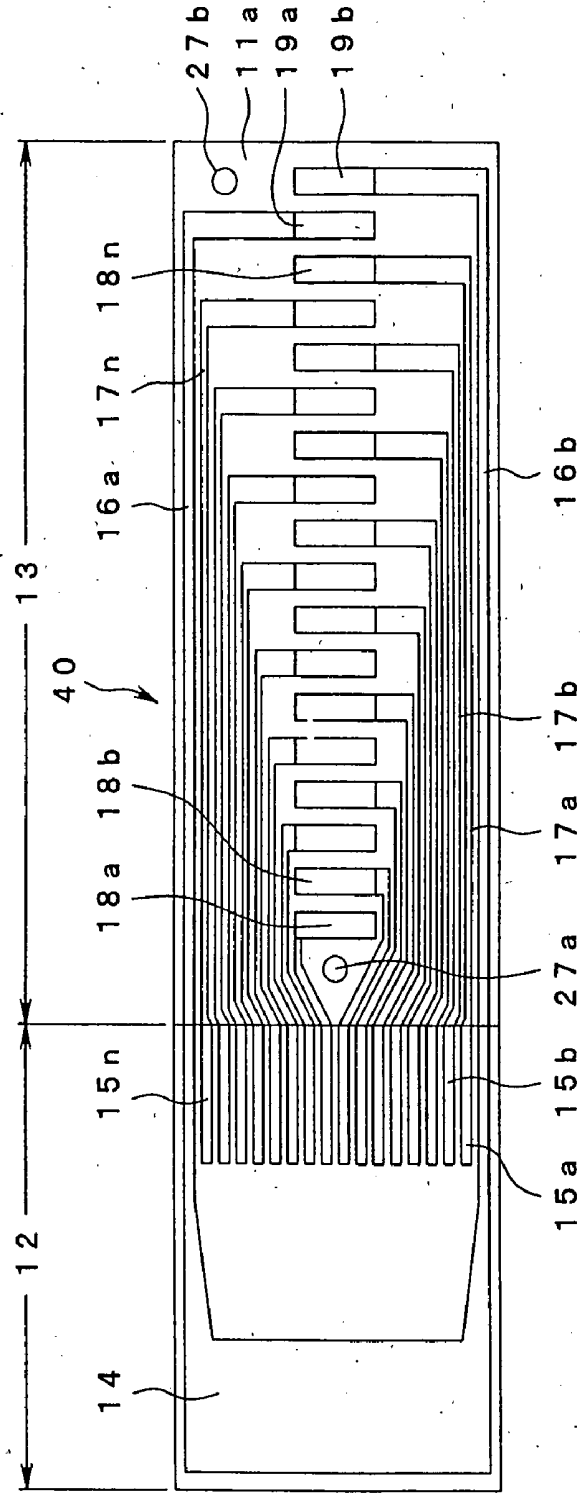

FIG. 9

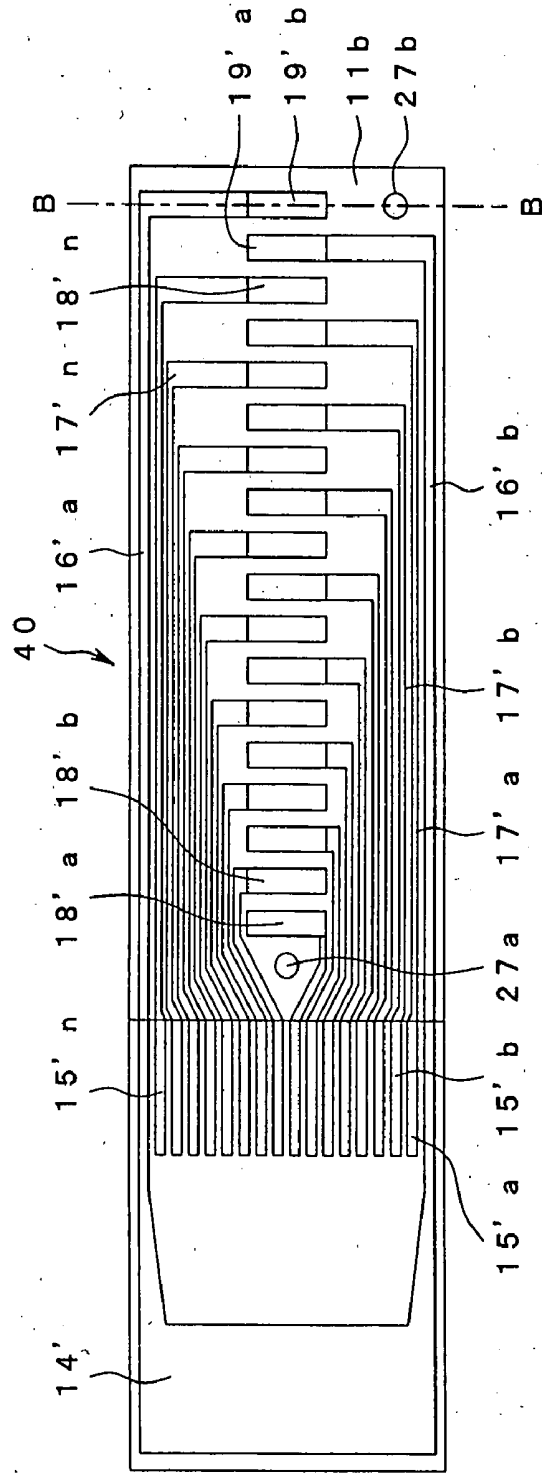

FIG. 10

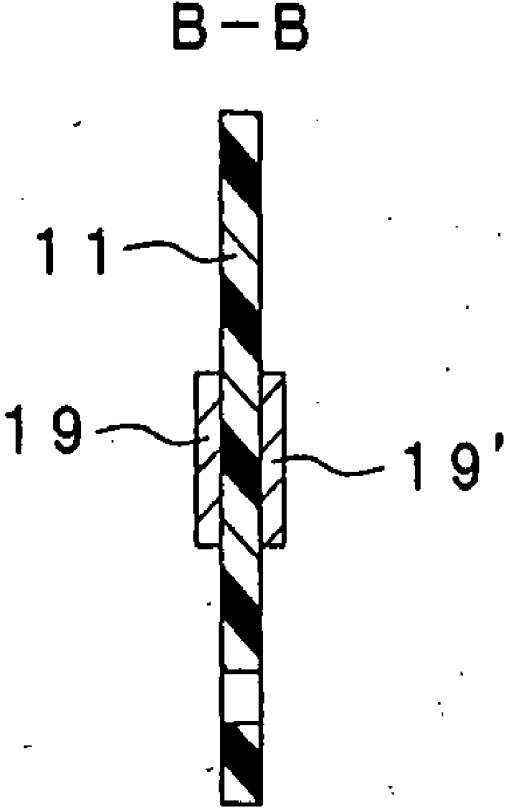

FIG. 11

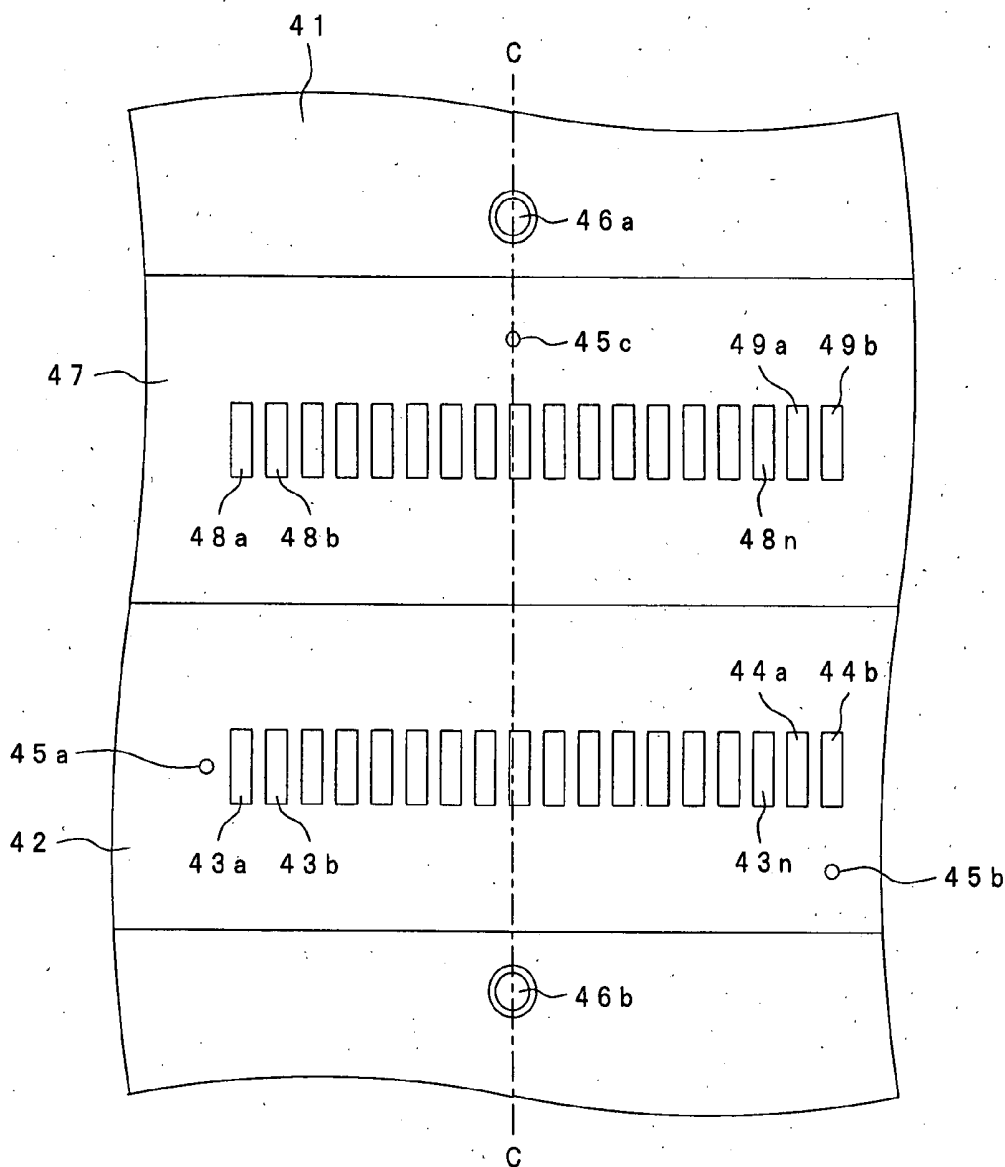

FIG. 12

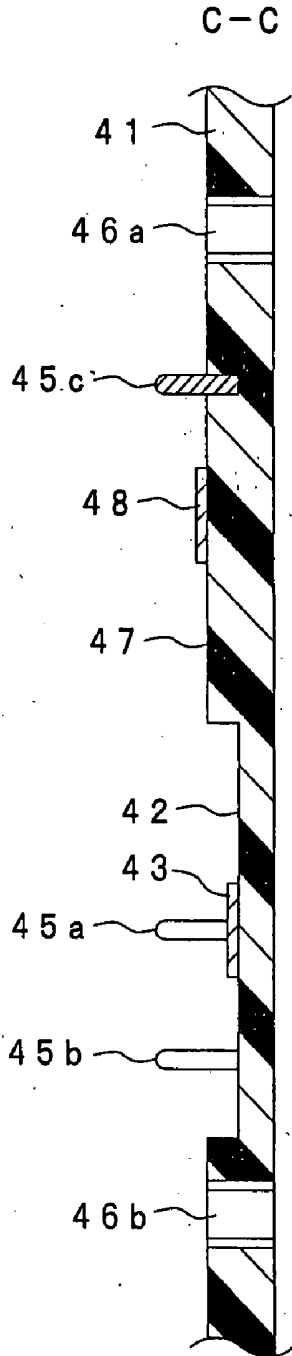

FIG. 13

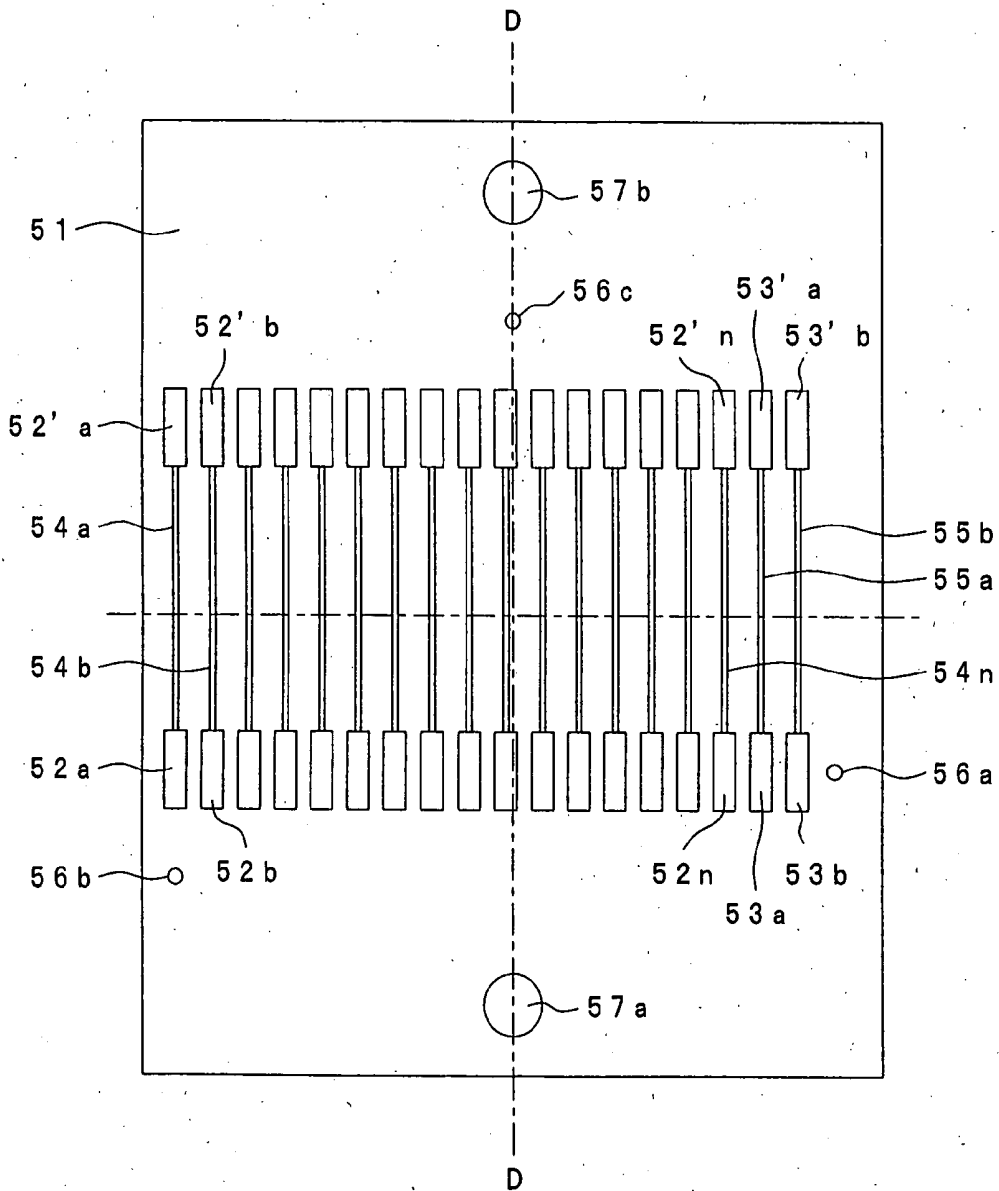

FIG. 14

D-D

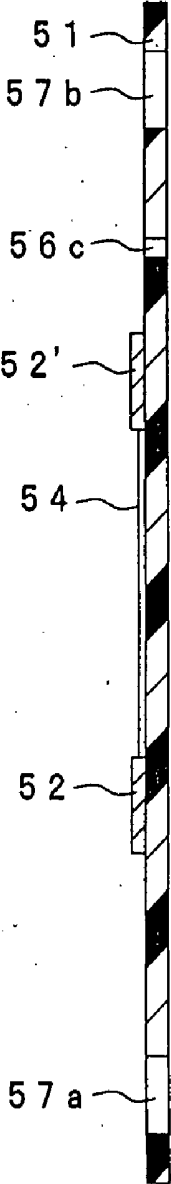

FIG. 15

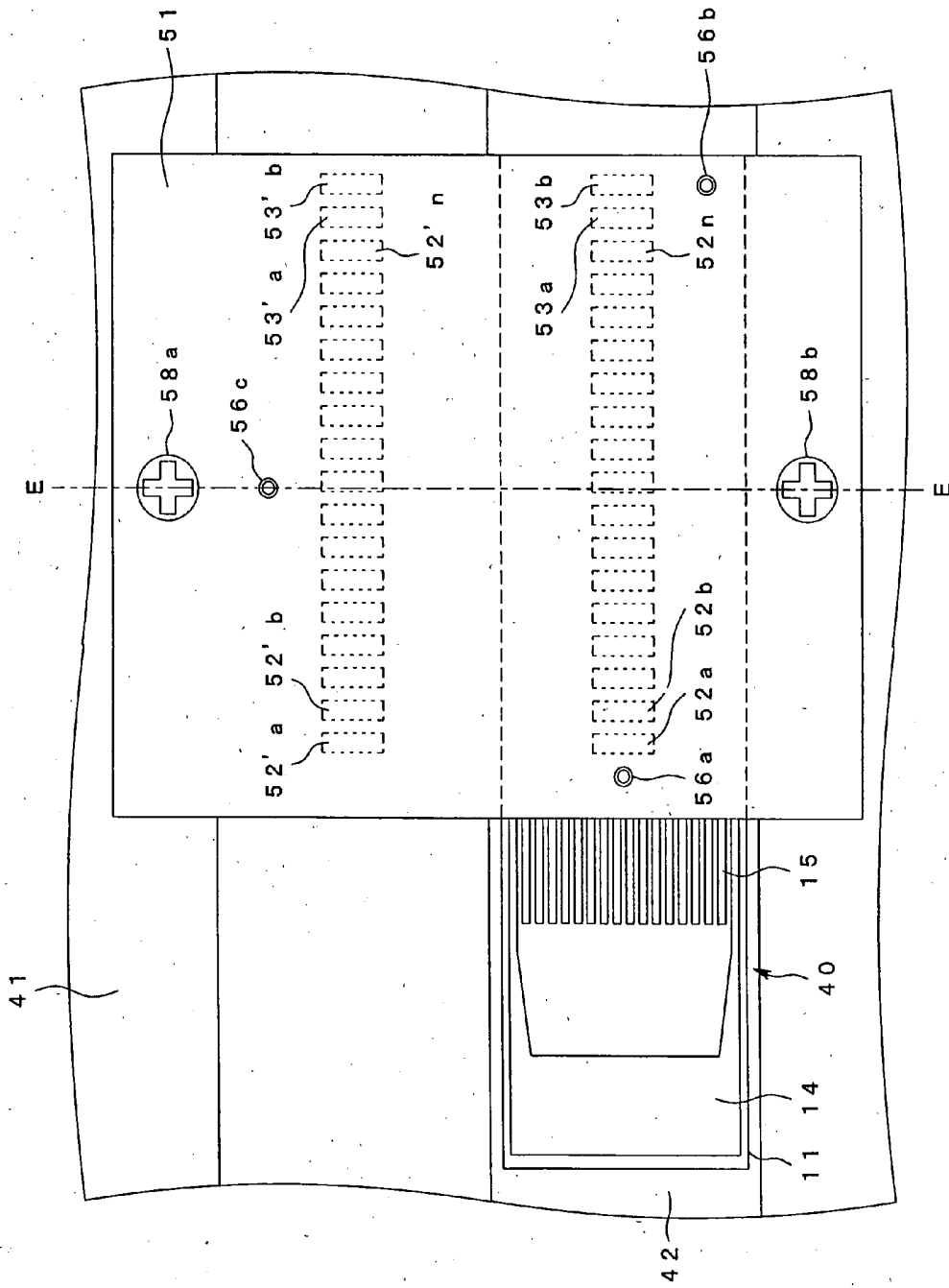

FIG. 16

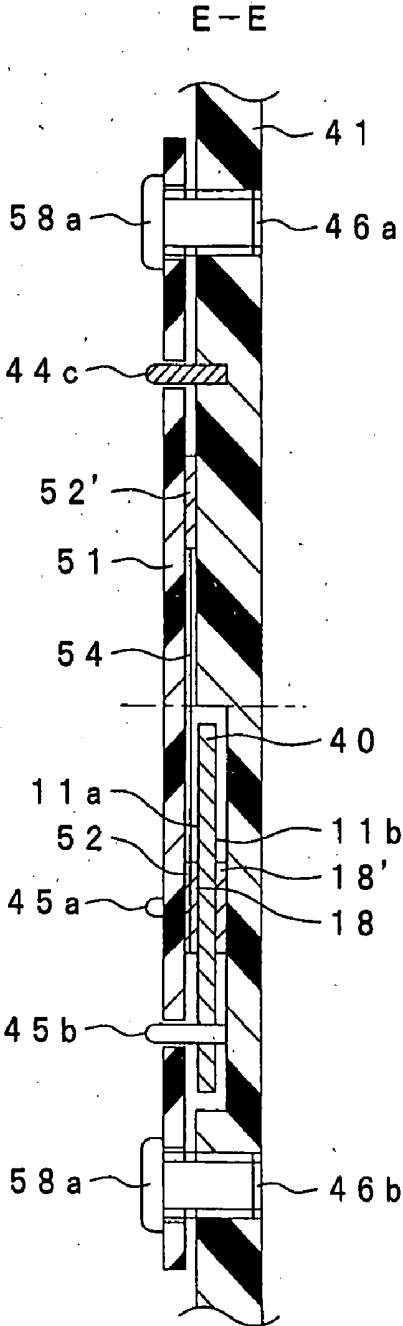

FIG.17

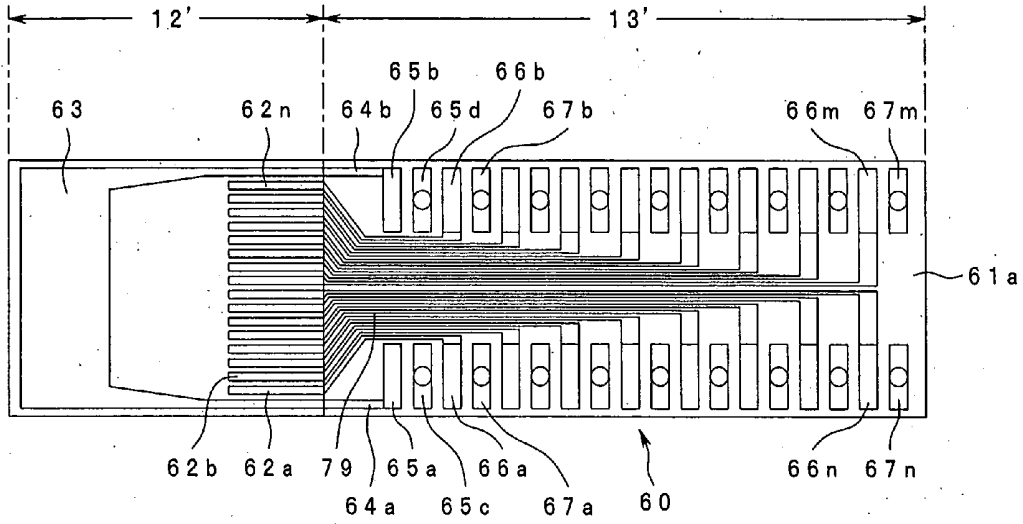
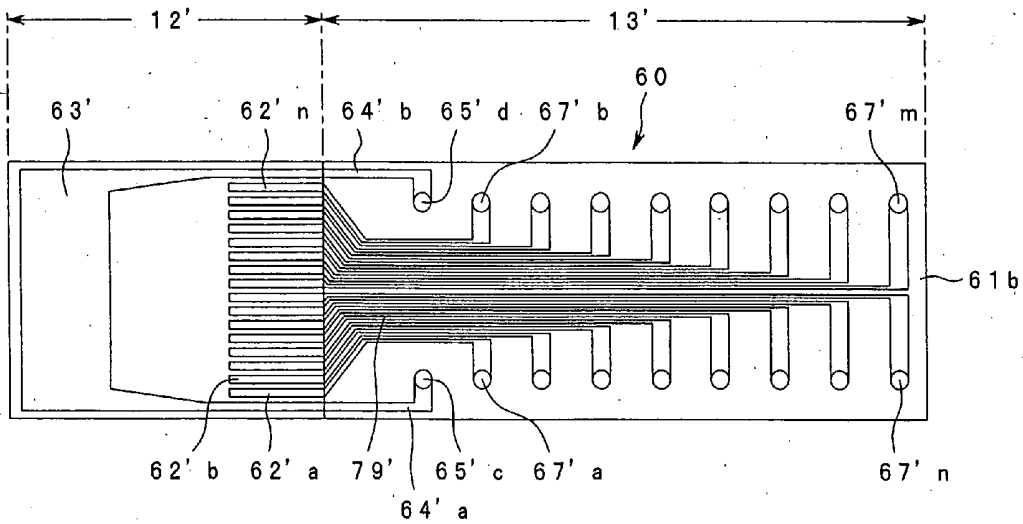

FIG.18



ULTRASONIC ENDOSCOPE AND ULTRASONIC SIGNAL CABLE CONNECTOR DEVICE

[0001] This application claims benefit of Japanese Application No. 2003-435623 filed on Dec. 26, 2003, the contents of which are incorporated by this reference.

BACKGROUND OF THE INVENTION

[0002] 1. Field of the Invention

[0003] The present invention relates to an ultrasonic endoscope having an ultrasonic connector that connects to ultrasonic measuring equipment and observes the body cavity using ultrasonic wave, and to an ultrasonic signal cable connector device.

[0004] 2. Description of the Related Art

[0005] Various types of endoscopes are widely used in the medical field, which are inserted into the body cavity to observe the living-body tissue or perform biopsy or treatment.

[0006] One type of such endoscopes is the ultrasonic endoscope. This ultrasonic endoscope has an ultrasonic transducer on the distal end of the insertion portion that is to be inserted in the body cavity. The ultrasonic transducer of this ultrasonic endoscope transmits ultrasonic wave to the living-body tissue, and receives the ultrasonic wave reflected from the living-body tissue. Thus, an ultrasonic tomographic image is generated by the various observation equipment connected to the ultrasonic endoscope, and the living-body tissue can be observed.

[0007] This ultrasonic endoscope is provided on the proximal end portion of the ultrasonic signal cable, as described in Japanese Patent Application Publication No. 2000-139927 for example, and has an ultrasonic connector that connects to an ultrasonic measuring equipment. This ultrasonic connector is provided with, for example, four Flexible Printed Circuits (hereafter "FPC"). The four FPCs each are connected to one end of each of multiple groups of signal lines. Further, the other end of each group of the multiple signal lines is connected to piezoelectric elements making up an electronic scanning ultrasonic transducer.

[0008] The FPCs and the multiple signal lines divided into groups are connected by the signal lines being soldered to contact pads provided on the FPCs.

[0009] Further, an FPC extension connecting pad is made for connecting an extension FPC. One end of this extension FPC can be inserted into the FPC connector of the ultrasonic connector and fixed. This FPC and the extension FPC are connected by the extension FPC connecting pad provided on the FPC being soldered to the pad provided on the extension FPC.

[0010] Further, the multiple signal lines extending from the ultrasonic transducer of the ultrasonic endoscope are divided into multiple groups, with an FPC disposed for each group.

[0011] A relatively large number, more than several dozen, of the above-described signals lines are built in, although this depends upon the number of piezoelectric elements. Therefore, the ultrasonic signal cable can have a narrower external diameter, the width of the multiple piezoelectric elements can be set narrow, and the electric connecting unit

of the signal lines can also be set narrow, resulting in the much narrower diameter of the signal lines, as illustrated in the drawings of Japanese Patent Application Publication No. 2000-139927.

[0012] Further, the dimensions of the FPCs connected with the ultrasonic signal cable need to be smaller in diameter than that of the ultrasonic signal cable channel, in order to pass through the ultrasonic signal cable channel which has a small diameter, that is positioned in the insertion unit and so forth.

[0013] Therefore, the land width and the land spacing of the contact pad provided on the FPC is made to be very small. Accordingly, the assembly worker needs to have a high degree of skill for soldering the extremely fine signal lines to the contact pad for electric connection.

[0014] On the other hand, the FPC connector width and the FPC connector spacing of the multiple FPC connectors provided on the connecting connector of the ultrasonic connector are set relatively wide. Thus, the multiple FPC connectors are arranged so as to avoid contact failure. This ultrasonic connector has an extension FPC for ease of attaching to the connecting connector, and the extension FPC has a contact pad wherein the pad width and pad spacing is set so as to correspond to the FPC connector.

SUMMARY OF THE INVENTION

[0015] According to one aspect of the present invention, an ultrasonic signal cable connector device, to be used with an ultrasonic endoscope device comprising an ultrasonic endoscope having an electronic scanning ultrasonic transducer provided on an insertion tip to be inserted in the body cavity, for generating ultrasonic wave as to the living-body tissue cavity and receiving the ultrasonic wave reflected from the body cavity tissue so as to generate ultrasonic signals, and ultrasonic measuring equipment for performing driving control of the ultrasonic transducer of the ultrasonic endoscope and generating ultrasonic image signals generated from the ultrasonic signal, comprises: an ultrasonic signal cable having a plurality of signal lines connected to the electronic scanning ultrasonic transducer; an ultrasonic connector for connecting the ultrasonic signal cable to the ultrasonic measuring equipment; a rectangular wiring board that has approximately the same or smaller width dimension as the external diameter of the ultrasonic signal cable; a plurality of signal line connecting lands arrayed in parallel on the surface of one of the short sides of the wiring board for electrically connecting the plurality of signal lines of the ultrasonic signal cable; a plurality of contact piece lands arrayed in a column longitudinally on the surface of the wiring board for electrically connecting the plurality of connecting connector pieces provided to the ultrasonic connector; and a plurality of wiring patterns for connecting the plurality of signal line connecting lands and contact piece lands that are provided on the surface of the wiring board.

[0016] The above and other objects, features and advantages of the invention will become more clearly understood from the following description referring to the accompanying drawings.

BRIEF DESCRIPTION OF THE DRAWINGS

[0017] FIG. 1 is a description diagram illustrating the configuration of an ultrasonic endoscope according to a first embodiment of the present invention;

[0018] FIG. 2 is a cross-sectional diagram illustrating the configuration of an ultrasonic connector according to the first embodiment of the present invention;

[0019] FIG. 3 is a plan view illustrating the configuration of an ultrasonic signal cable according to the first embodiment of the present invention;

[0020] FIG. 4 is a front view illustrating the configuration of an ultrasonic signal cable connector device according to the first embodiment of the present invention;

[0021] FIG. 5 is a back view illustrating the configuration of a connector receptacle provided on the ultrasonic connector that is connected to the ultrasonic signal cable connector device according to the first embodiment of the present invention;

[0022] FIG. 6 is a plan view illustrating the attached state of the ultrasonic signal cable connector device and the connector receptacle according to the first embodiment of the present invention;

[0023] FIG. 7 is a sectional view illustrating the attached state of the ultrasonic signal cable connector device and the connector receptacle according to the first embodiment of the present invention;

[0024] FIG. 8 is a front view illustrating the configuration of the ultrasonic signal cable connector device according to a second embodiment of the present invention;

[0025] FIG. 9 is a back view illustrating the configuration of the ultrasonic signal cable connector device according to the second embodiment of the present invention;

[0026] FIG. 10 is a cross-sectional view illustrating the configuration of the ultrasonic signal cable connector device according to the second embodiment of the present invention;

[0027] FIG. 11 is a plan view illustrating the configuration of a connector receptacle wherein the ultrasonic signal cable connector of the ultrasonic signal cable connector device according to the second embodiment of the present invention is attached;

[0028] FIG. 12 is a cross-sectional view illustrating the configuration of the connector receptacle wherein the ultrasonic signal cable connector of the ultrasonic signal cable connector device according to the second embodiment of the present invention is attached;

[0029] FIG. 13 is a plan view illustrating the configuration of a connecting board for connecting the ultrasonic signal cable connector of the ultrasonic signal cable connector device and the connector receptacle according to the second embodiment of the present invention;

[0030] FIG. 14 is a cross-sectional view illustrating the configuration of a connecting board for connecting the ultrasonic signal cable connector of the ultrasonic signal cable connector device and the connector receptacle according to the second embodiment of the present invention;

[0031] FIG. 15 is a plan view illustrating the attached state of the ultrasonic signal cable connector of the ultrasonic signal cable connector device and the connector receptacle according to the second embodiment of the present invention;

[0032] FIG. 16 is a cross-sectional view illustrating the attached state of the ultrasonic signal cable connector of the ultrasonic signal cable connector device and the connector receptacle according to the second embodiment of the present invention;

[0033] FIG. 17 is a front view illustrating the configuration of the ultrasonic signal cable connector of the ultrasonic signal cable connector device according to a third embodiment of the present invention; and

[0034] FIG. 18 is a back view illustrating the configuration of the ultrasonic signal cable connector of the ultrasonic signal cable connector device according to the third embodiment of the present invention.

DETAILED DESCRIPTION OF THE PREFERRED EMBODIMENTS

First Embodiment

[0035] The configuration of the ultrasonic endoscope of the present invention will be described below with reference to the drawings. In FIG. 1, an ultrasonic endoscope 61 primarily comprises an insertion portion 62 that is inserted into the body cavity, an operating unit 63 provided on the rear end of the insertion portion 62, an eyepiece 64 provided on the proximal end of the operating unit 63, a universal cord 65 extending from the operating unit 63, an endoscope connector 66 provided on the proximal end of the universal cord 65 that is connected to a light source device (not shown), and an ultrasonic signal cable 67 that extends from the endoscope connector 66 and has an ultrasonic connector 68 on the distal end thereof. Now, the ultrasonic connector 68 which is this connector unit is connected to an ultrasonic measuring equipment (not shown).

[0036] The insertion portion 62 is formed with a small diameter. The insertion portion 62 comprises, in order from the distal end, a hard distal-end portion 69, a bending portion 70, and a long flexible portion 71 that is capable of bending. An ultrasonic transducer unit 73 is located on the distal end side of the hard distal-end portion 69. An electronic scanning ultrasonic transducer, wherein multiple piezoelectric elements that send and receive ultrasonic wave are arrayed, is located on the ultrasonic transducer unit 73.

[0037] Disposed on the operating unit 63 are a bending knob 72, an air and water feed button, a suction button, an insertion opening for forceps treatment instruments, and so forth.

[0038] The bending knob 72 is an operating knob for bending the bending portion 70 of the insertion portion 62 in the desired direction. The air and water feed button is operated in the moment wherein air or water is fed to the air and water feeding channel provided within the insertion portion 62. The suction button is operated in the moment wherein air or water is suctioned into the suction channel. The insertion opening for forceps treatment instruments is an opening for the forceps channel through which forceps treatment instruments are inserted.

[0039] The optical image of the internal body cavity from the object lens provided on the hard distal-end portion 69 of the insertion portion 62 is guided by the image guide, and visually confirmed at the eyepiece 64.

[0040] The illumination light from the light source device wherein the endoscope connector 66 is connected is guided through the universal cord 65, and a light guide that is passed through the inside of the operating unit 63 and the insertion portion 62. The illumination light is then emitted from the hard distal-end portion 69 onto the observation portions in the body cavity. The ultrasonic signal cable 67 that extends from the endoscope connector 66 is passed through the universal cord 65, and the ultrasonic signal cable channel (not shown) provided on the insertion portion 62 and the operating unit 63. One end of the ultrasonic signal cable 67 is connected to the electronic scanning ultrasonic transducer of the ultrasonic transducer unit 73, and the other end thereof is connected to the ultrasonic connector 68. The ultrasonic connector 68 is connected to the ultrasonic measuring equipment (not shown) that performs sending/receiving drive control of the ultrasonic wave from the electronic scanning ultrasonic transducer of the ultrasonic transducer unit 73.

[0041] Further, the ultrasonic signal cable 67 is connected to the multiple piezoelectric elements of the electronic scanning ultrasonic transducer provided in the ultrasonic transducer unit 73. Multiple signal lines which are signal core lines, to be described below, that send/receive the ultrasonic signal from the piezoelectric elements, pass through the inside of the ultrasonic signal cable 67. These multiple signal lines are grouped in groups with a predetermined number of lines each.

[0042] The ends of the multiple signal lines in the ultrasonic signal cable 67 are connected electrically to the multiple piezoelectric elements of the electronic scanning ultrasonic transducer provided on the ultrasonic transducer unit 73. The multiple signal lines are separated into multiple bundles as will be described below, and are inserted in the ultrasonic signal cable channel opening provided on the hard distal-end portion 69 of the insertion portion 62 from the other end side that is not connected with the piezoelectric elements. The ultrasonic signal cable 67 passes through the ultrasonic signal cable channel and is connected to the ultrasonic connector 68. Now, the ultrasonic signal cable channel is an insertion hole that is located within the bending portion 70 of the insertion portion 62, the flexible portion 71, the operating unit 63, the universal cord 65, and the endoscope connector 66.

[0043] An ultrasonic signal cable connector device to be described below is provided on the distal end of the signal lines of each ultrasonic signal cable 67 for each group wherein the signal lines have been grouped together. This ultrasonic signal cable connector device is connected to the connecting connector 20 (see FIG. 2) of the ultrasonic connector 68.

[0044] Next, the configuration of the ultrasonic connector 68 will be described, with reference to FIG. 2. FIG. 2 is a cross-sectional diagram of an ultrasonic connector.

[0045] The ultrasonic connector 68 mainly comprises a metal frame 96 in an approximately rectangular box shape, a cable insertion hole 100, multiple connector receptacles 20, four to be specific, an insulating sheet 103, multiple matching boards 101, two to be specific, a base board 104, a metal board 107, and a connector unit 108. The cable insertion hole 100 is an insertion hole for inserting the ultrasonic signal cable 67 into the metal frame 96. Multiple ultrasonic signal cable connector devices to be described

below, which are provided on the distal end of the ultrasonic signal cable 67 that is inserted from the cable insertion hole 100, are attached to the connector receptacle 20. The ultrasonic signal cable connector devices are each attached to the connecting connectors 102, and in the moment wherein they are connected, the insulating sheet 103 is provided between the metal frame 96 and the ultrasonic signal cable connector device. In other words, the insulating sheet 103 insulates the metal frame 96 and the ultrasonic signal cable connector device in the moment that the ultrasonic signal cable connector device is connected to the connector receptacle 20. The matching boards 101 are electrically connected to the multiple connector receptacles 20. The matching boards 101 are boards wherein matching circuits are formed. The matching circuits perform the matching between the ultrasonic measuring equipment and the electronic scanning ultrasonic transducer that is connected to the ultrasonic signal cable 67. The base board 104 is connected to the multiple matching boards 101. Further, the base board 104 has multiple connector pins for the purpose of connecting to the ultrasonic measuring equipment. The metal board 107 covers the area of the connector pin of the base board 104, and is fixed to the metal frame 96. In the moment that the ultrasonic connector 68 is connected to the ultrasonic measuring equipment, the connector unit 108 has the metal frame 96 and the metal board 107 to be at the same electric potential as the reference potential of the ultrasonic measuring equipment.

[0046] The configuration of the ultrasonic signal cable 67 that is connected to the ultrasonic connector 68 will be described with FIG. 3. The ultrasonic signal cable 67 comprises an overall insulator covering 87, multiple coaxial lines 85a through 85d, and an overall shield 86 that bundles the coaxial lines 85a through 85d. Multiple signal core lines 81 are located within the coaxial lines 85a through 85d.

[0047] The multiple signal core lines 81 are each covered with an insulator layer 82. A shield 83 surrounds each of the insulator layers 82. An insulator covering layer 84 surrounds and covers the shields 83. In other words, inside of the coaxial lines 85a through 85d, the signal core lines 81 that are covered by the insulator layer 82, the shield 83 and the insulator covering layer 84 are grouped together with several lines in a unit.

[0048] On the distal ends of the multiple coaxial lines 85a through 85d, ultrasonic signal cable connector devices 10a through 10d that are connecting boards are each connected (hereafter, the ultrasonic signal cable connector devices 10a through 10d may be individually or collectively referred to as "ultrasonic signal cable connector device 10"). The ultrasonic signal cable connector devices 10a through 10d are connected, in order, along the length of the ultrasonic signal cable 67 on the distal ends of the coaxial lines 85a through 85d, each set apart only the length L of the ultrasonic signal cable connector device 10. In other words, the ultrasonic signal cable connector devices 10a through 10d are located in a perpendicular direction to the length of the ultrasonic signal cable 67, so as not to overlap the others.

[0049] The ultrasonic signal cable connector device will be described below with reference to FIGS. 4 through 6. FIG. 4 is a front view illustrating the configuration of the first embodiment of an ultrasonic signal cable connector device relating to the present invention, FIG. 5 is a back

view illustrating the configuration of a connecting board of a connector receptacle provided on the ultrasonic connector of the first embodiment of the ultrasonic signal cable connector device relating to of the present invention, **FIG. 6** is a plan view illustrating the attached state of the ultrasonic signal cable connector device to the ultrasonic connector relating to the present invention, and **FIG. 7** is a sectional view illustrating the attached state of the ultrasonic signal cable connector device to the cable connector relating to the present invention.

[0050] As illustrated in **FIG. 4**, the ultrasonic signal cable connector device (hereafter referred to as "cable connector") **10** relating to the first embodiment of the present invention is a wiring board **11** wherein connection lands or wiring patterns are formed on the face of the insulation base board.

[0051] The wiring board **11** is formed in a rectangular shape, wherein the length of at least the short side is formed to be equal to or less than the external diameter of the ultrasonic signal cable **67** that is passed through the ultrasonic signal cable channel of the ultrasonic endoscope **61**, or less than the internal diameter of the ultrasonic signal cable channel. Now, the wiring board **11** can be either a hard board or a soft flexible board.

[0052] The wiring board **11** is divided into a cable connecting portion **12** that connects the ultrasonic signal cable **67** lengthwise, and a connector connecting unit **13** that connects the ultrasonic connector **68**. Multiple signal line connecting lands **15a** through **15n** and a grounding land **14** are provided on the cable connecting portion **12**.

[0053] The signal line connecting lands **15a** through **15n** are located in a parallel line in the lengthwise direction of the wiring board **11**, and are electrically connected to the multiple signal core lines **81** of the coaxial lines **85a** through **85d** of the ultrasonic signal cable **67** by means of soldering.

[0054] The grounding land **14** is electrically connected to the multiple shields **83** that are covering the multiple signal core lines **81** and the insulator layers **82** by means of soldering.

[0055] The connector connecting unit **13** provides multiple grounding patterns, two to be specific, **16a** and **16b**, multiple wiring patterns **17a** through **17n**, multiple contact piece lands **18a** through **18n**, and multiple grounding contact piece lands, two to be specific, **19a** and **19b**.

[0056] The multiple contact piece lands **18a** through **18n** are formed wherein each is approximately the same shape and size, and are located in a vertical row with approximately equal spacing therebetween, along the lengthwise direction of the central portion of the wiring board **11**.

[0057] The multiple grounding contact piece lands **19a** and **19b** are formed wherein each is approximately the same shape and size as the contact piece lands **18a** through **18n**, and are located in a vertical row on the distal end side of the contact piece lands **18a** through **18n** (to the right side in **FIG. 3**), with approximately equal spacing between.

[0058] The grounding patterns **16a** and **16b** extend from the ends of both sides of the grounding lands **14** of the cable connecting portion **12**, along the length of the surface of the wiring board **11**, and are each connected to the corresponding grounding contact piece lands **19a** and **19b**.

[0059] The wiring patterns **17a** through **17n** extend from the signal line connecting lands **15a** through **15n** of the cable connecting portion **12**, along the length of the surface of the wiring board **11**, and are each connected to the corresponding contact piece lands **18a** through **18n**.

[0060] In other words, when the multiple signal core lines **81** of the ultrasonic signal cable **67** are connected by soldering to each of the signal line connecting lands **15a** through **15n** of the cable connecting portion **12**, connection thereof is made electrically to the contact piece lands **18a** through **18n** via the wiring patterns **17a** through **17n** of the connector connection unit **13**.

[0061] Further, when each of the shields **83** of the signal core lines **81** are connected by soldering to the grounding land **14** of the cable connecting portion **12**, connection thereof is made electrically to the grounding contact piece lands **19a** and **19b** via the grounding patterns **16a** and **16b** of the connector connection unit **13**.

[0062] The cable connector **10** thus configured is connected to each of the coaxial lines **85a** through **85d** on the ultrasonic signal cable **67**.

[0063] As illustrated in **FIG. 5**, the above-described connector receptacle **20** has on the surface of the wiring board **21** multiple contact piece lands **18a** through **18n** provided on the connector connecting unit **13** of the cable connector **10**, and multiple contact point lands **22a** through **22n** wherein each is approximately the same shape and size as the grounding contact piece lands **19a** and **19b**, with approximately equal spacing between, and multiple grounding contact point lands, two to be specific, **23a** and **23b**.

[0064] Multiple connecting patterns **24a** through **24n** and multiple ground patterns, two to be specific, **25a** and **26b**, each extend from the contact point lands **22a** through **22n** and the grounding contact point lands **23a** and **23b**, and are connected to the matching board **101**.

[0065] In other words, the multiple contact point lands **22a** through **22n** and the two grounding contact point lands **23a** and **23b** that are provided on the surface of the wiring board **21** of the connector receptacle **20** are formed in a shape and size so as to overlap and make contact with the contact piece lands **18a** through **18n** and the grounding contact piece lands **19a** and **19b** respectively of the connector connecting unit **13** of the cable connector **10**.

[0066] A connector attaching frame **26** that surrounds three sides of the area formed by the contact point lands **22a** through **22n**, the grounding contact point lands **23a** and **23b**, the wiring patterns **24a** through **24n**, and the grounding patterns **25a** and **25b**, is provided on the surface of the wiring board **21** of the connector receptacle **20**. The connector attaching frame **26** is approximately the same shape as the wiring board **11** of the connector connecting unit **13** of the cable connector **10**, and is a member for positioning of the connector connecting unit **13** in the moment that the connector connecting unit **13** is overlapped with the connector receptacle **20**.

[0067] The method for connecting the cable connector **10** and the connector receptacle **20** will be described with reference to **FIG. 6**. The connector connecting unit **13** of the cable connector **10** is attached inside the connector attaching frame **26**. When the connector connecting unit **13** is attached

to the connector attaching frame 26, the contact piece lands 18a through 18n and the grounding contact piece lands 19a and 19b of the connector connecting unit 95 (see FIG. 2) of the cable connector 10 make contact with the contact point lands 22a through 22n and the ground contact point lands 23a and 23b of the connector receptacle 20, respectively.

[0068] The cable connector 10 that is attached to the connector attaching frame 26 is pressed down and fixed by a pressing fixation piece 31 of the connector receptacle 20. The pressing fixation piece 31 comprises a pressing face 32 that makes contact with at least the back face of the connector connecting unit 13 (see FIG. 4) of the cable connector 10, multiple recessed portions, two to be specific, 33a and 33b that give elasticity to the pressing face 32 as well as avoids contact with the connector attaching frame 26, multiple leg portions, two to be specific, 34a and 34b, extending from the recessed portions 33a and 33b that are located on the surface of the wiring board 21 of the connector receptacle 20, and multiple external thread screws, two to be specific, 35a and 35b, that fix the leg portions 34a and 34b to the wiring board 21 of the connector receptacle 20.

[0069] In other words, as illustrated in FIG. 7, after the connector connecting unit 13 of the cable connector 10 is attached to the connector attaching frame 26 of the connector receptacle 20, the pressing fixation piece 31 is placed on the back face of the cable connector 10, and fixes the leg portions 34a and 34b of the pressing fixation piece 31 with the two external thread screws 35a and 35b. Thus, in order for the pressing face 32 of the pressing fixation piece 31 to press the cable connector 10, the contact piece lands 17a through 17n and the grounding contact piece lands 18a and 18b of the connector connecting unit 13 of the cable connector 10 are pressed on to the corresponding contact point lands 22a through 22n and the grounding contact point lands 23 and 23b respectively, and each makes contact.

[0070] As described above, the cable connector 10 has a rectangular shape wiring board 11 wherein the width is less than at least the internal diameter of the ultrasonic signal cable channel of the endoscope insertion portion 62. The wiring board 11 of the cable connector 10 comprises two sections, the cable connecting portion 12 that has grounding lands 14 that are connected to the shields 83 and the multiple signal line connecting lands 15a through 15n that are positioned in a row to connect to the corresponding multiple signal core lines 81 of the ultrasonic signal cable 67, and the connector connecting unit 13 that has multiple contact piece lands 18a through 18n and grounding lands 19a and 19b that are positioned in a vertical row with approximately equal spacing in the center portion in the lengthwise direction of the wiring board 11 that are each connected to the signal line connecting lands 15a through 15n and the grounding land 14.

[0071] The cable connector 10 connects the contact piece lands 18a through 18n and the grounding lands 19a and 19b of the cable connector 10 to the corresponding contact point lands 22a through 22n and the grounding contact point lands 23a and 23b of the connector receptacle 20, by overlapping the connector receptacle 20 provided on the ultrasonic connector 68, and also by pressing and fixing the pressing fixation piece 31.

[0072] Now, an electroconductive member such as electroconductive rubber or the like may be placed on the

contact surfaces between the lands 18a through 18n, 19a, 19b, 22a through 22n, 23a, and 23b, so that conductivity is ensured upon the contact piece lands 18a through 18n and the grounding lands 19a and 19b of the cable connector 10 each making contact with the corresponding contact point lands 22a through 22n and the grounding contact point lands 23a and 23b of the connector receptacle 20.

[0073] Consequently, with the ultrasonic signal cable connector device 10 of the present embodiment, soldering work to connect to the connecting connector 102 of the ultrasonic connector 68 can be eliminated. Therefore, connection to the ultrasonic connector 68 is made easier and can be simplified.

Second Embodiment

[0074] Next, an ultrasonic signal cable connector device relating to a second embodiment of the present invention will be described with reference to FIGS. 8 through 16. Now, only the points of the present embodiment that differ from the configuration of the first embodiment will be described; configurations which are the same will be denoted with the same reference numerals and description thereof will be omitted.

[0075] FIG. 8 is a plan view of the ultrasonic signal cable connector device, FIG. 9 is a back view of the ultrasonic signal cable connector device, FIG. 10 is a cross-sectional view of the ultrasonic signal cable connector device, FIG. 11 is a plan view illustrating the configuration of the connector receptacle wherein the ultrasonic signal cable connector of the ultrasonic signal cable connector device is attached, and FIG. 12 is a cross-sectional view illustrating the configuration of the connector receptacle wherein the ultrasonic signal cable connector of the ultrasonic signal cable connector device is attached. FIG. 13 is a plan view illustrating the configuration of a connecting board for connecting the ultrasonic signal cable connector of the ultrasonic signal cable connector device and the connector receptacle, FIG. 14 is a cross-sectional view illustrating the configuration of a connecting board for connecting the ultrasonic signal cable connector of the ultrasonic signal cable connector device and the connector receptacle, FIG. 15 is a plan view illustrating the attached state of the ultrasonic signal cable connector of the ultrasonic signal cable connector device and the connector receptacle, and FIG. 16 is a cross-sectional view illustrating the attached state of the ultrasonic signal cable connector of the ultrasonic signal cable connector device and the connector receptacle.

[0076] The above-described cable connector 10 according to the first embodiment of the present invention has a grounding land 14, a signal line connecting land 15, a grounding pattern 16, a wiring pattern 17, an contact piece land 18, and a grounding contact piece land 19 on one surface of the wiring board 11.

[0077] On the other hand, the cable connector 40 of the present embodiment has two grounding lands 14 and 14', one on each face, multiple signal line connecting lands 15a through 15n and 15'a through 15'n, a total of four grounding patterns 16a, 16b, 16'a, 16'b, two on each face, multiple wiring patterns 17a through 17n and 17'a through 17'n, multiple contact piece lands 18a through 18n and 18'a through 18'n, and a total of four grounding contact piece lands 19a, 19b, 19'a, 19'b, two on each face, on both faces

11a and 11b of the wiring board 11, as illustrated in FIGS. 8 through 10. Hereafter, the description will refer to only the numeral of the reference numeral for each land and each pattern (for example, the signal line connecting lands 15a through 15n and 15'a through 15'n will be referred to as signal line connecting lands 15 and 15').

[0078] The grounding lands 14 and 14', the signal line connecting lands 15 and 15', the grounding patterns 16 and 16', the wiring pattern 17 and 17', the contact piece lands 18 and 18', and the grounding contact piece lands 19 and 19' that are provided on both faces 11a and 11b of the wiring board 11 are formed with approximately the same shape and size for each land and pattern. Now, the two faces 11a and 11b of the wiring board 11 may be referred to as the front face 11a and back face 11b in the description below.

[0079] Thus, the two faces 11a and 11b of the wiring board 11 each has two grounding lands 14 and 14', one on each face, multiple signal line connecting lands 15 and 15', a total of four grounding patterns 16 and 16', two on each face, multiple wiring patterns 17 and 17', multiple contact piece lands 18 and 18', and a total of four grounding contact piece lands 19 and 19', two on each face, and thus the number of signal lines on the ultrasonic signal cable 67 connected to the cable connector 40 can be approximately doubled. In other words, the two coaxial lines 85a and 85b of the ultrasonic signal cable 67 described with reference to FIG. 3 can be grouped together as one, and further, the multiple signal core lines 81 within the coaxial lines 85a and 85b can be connected to one cable connector 40.

[0080] Now, the connector connecting unit 13 of the cable connector 40 has a first positioning hole 27a near the center of the cable connecting portion 12, and a second positioning hole 27b near one corner of the distal end side of the connector connecting unit 13.

[0081] First and second positioning shafts 45a and 45b of the connector receptacle 41 that is the wiring board to be described below, which is the connecting receiving unit 20 in the first embodiment, provided on the connecting connector 102 of the ultrasonic connector 68, are passed through the first and second positioning holes 27a and 27b.

[0082] Next, the connector receptacle 41 provided on the connecting connector 102 of the ultrasonic connector 68 that corresponds to the cable connector 40 wherein the ultrasonic signal cable 67 is capable of being connected will be described with reference to FIGS. 11 and 12.

[0083] On one face of the connector receptacle 41 a rectangular recessed portion 42 wherein the cable connector 40 attaches is formed. The recessed portion 42 is formed to have approximately the same thickness as the thickness of the wiring board 11 of the cable connector 40, and is a recessed portion formed in approximately the same shape as the wiring board 11. In the center portion in the lengthwise direction of the recessed portion 42 bottom face is provided the multiple first contact point lands 43a through 43n and multiple first grounding contact points lands, two to be specific, 44a and 44b that are positioned with approximately equal spacing and formed to have approximately similar shape and size as the corresponding multiple contact piece lands 18'a through 18'n and the two grounding contact piece lands 19'a and 19'b provided on the back face 11b of the wiring board 11 of the cable connector 40.

[0084] A first positioning shaft 45a that is passed through the first positioning hole 27a of the cable connector 40, as seen in FIG. 11 near the left side in the drawing, of the first contact point lands 43a through 43n, is provided on the recessed portion 42 so as to protrude in the perpendicular direction from the bottom face thereof. Further, a second positioning shaft 45b that is passed through the second positioning hole 27b of the cable connector 40, as seen in FIG. 11 to the lower side, of the first contact point land 44b, is provided on the recessed portion 42 so as to protrude in the perpendicular direction from the front face thereof.

[0085] In other words, the two, first and second, positioning shafts 45a and 45b are passed through the two, first and second, positioning holes 27a and 27b of the wiring board 11 from the back face side of the cable connector 40, and the wiring board 11 is attached to the recessed portion 42. Thus, the contact piece lands 18'a through 18'n and the grounding contact piece lands 19'a and 19'b of the back face 11b of the wiring board 11 each makes contact with the corresponding first contact point lands 43a through 43n and the first grounding contact point lands 44a and 44b of the recessed portion 42.

[0086] Now, a wiring pattern and a grounding pattern for the purpose of connecting to the matching board 101 each extend from the first contact point lands 43a through 43n and the first grounding contact point lands 44a and 44b of the recessed portion 42, although this is not illustrated.

[0087] Further, multiple second contact point lands 48a through 48n and multiple second grounding contact point lands, two to be specific, 49a and 49b are formed on the plane portion 47 adjacent to the recessed portion 42 of the connector receptacle 41. The second contact point lands 48a through 48n and the grounding contact point lands 49a and 49b are formed to have approximately the same shape and size as the corresponding first contact point lands 43a through 43n and grounding contact point lands 44a and 44b, and are positioned on the surface of the plane portion 47 with approximately equal spacing.

[0088] A third positioning shaft 45c is provided near the side in the center section in the lengthwise direction (the upper part of FIG. 11) of the second contact point lands 48a through 48n of the plane portion 47. Now, two screw holes 46a and 46b, wherein the external thread screws are screwed in to attach and fix the connecting board 51 to be described below, are provided near one side corresponding to the lengthwise direction (the vertical direction of FIG. 11) of the recessed portion 42 and the plane portion 47 of the connector receptacle 41.

[0089] Now, a wiring pattern and a grounding pattern for the purpose of connecting to the matching board 101 each extend from the second contact point lands 48a through 48n and the second grounding contact point lands 49a and 49b of the plane portion 47, although this is not illustrated.

[0090] Next, the connecting board 51 will be described with reference to FIGS. 13 and 14. On one face of the connecting board 51, multiple third contact point lands 52a through 52n and multiple third grounding contact point lands, two to be specific, 53a and 53b are provided. The multiple third contact point lands 52a through 52n and the two grounding contact point lands 53a and 53b are formed in approximately the same shape and size so as to make

contact with the respective multiple contact piece lands **18a** through **18n** and the two grounding contact piece lands **19a** and **19b** provided on the front face **11a** of the wiring board **11** of the corresponding cable connector **40**, and are positioned with approximately equal spacing, and are located after the position is determined on one face of the connecting board **51**.

[0091] Further, multiple fourth contact point lands **52'a** through **52'n** and multiple fourth grounding contact point lands, two to be specific, **53'a** and **53'b** are provided on one side of the connecting board **51** so as to line up with the third contact point lands **52a** through **52n** and the third grounding contact point lands **53a** and **53b**. The fourth contact point lands **52'a** through **52'n** and the fourth grounding contact point lands **53'a** and **53'b** are formed in approximately the same shape and size so as to make contact with the corresponding second contact point lands **48a** through **48n** and the second grounding contact point lands **49a** and **49b** of the connector receptacle **41**, and are also positioned with approximately equal spacing and determined where to be positioned on the face of the connecting board **51**.

[0092] The third contact point lands **52a** through **52n** and the third grounding contact point lands **53a** and **53b** of the connecting board **51** are electrically connected to the corresponding fourth contact point lands **52'a** through **52'n** and the fourth grounding contact point lands **53'a** and **53'b** by the wiring patterns **54a** through **54n** or the grounding patterns **55a** and **55b**.

[0093] Further, first through third positioning holes **56a** through **56c** provided in the positions corresponding to the first through third positioning shafts **45a** through **45c** provided on the connector receptacle **41**, and screw openings **57a** and **57b** provided in the positions corresponding to the attaching screw holes **46a** and **46b** of the connector receptacle **41**, are bored in the connecting board **51**.

[0094] The connection of the cable connector **40**, the connector receptacle **41**, and the connecting board **51**, with such a configuration, will be described with reference to FIGS. 15 and 16.

[0095] The multiple signal core lines **81** (see FIG. 3) of the ultrasonic signal cable **67** are connected to the signal line connecting lands **15a** through **15n**, the grounding land **14**, the signal line connecting lands **15'a** through **15'n**, and the grounding land **14'** provided on both faces **11a** and **11b** of the wiring board **11** of the cable connector **40**.

[0096] For example, the signal core lines **81** and the shields **83** of the coaxial lines **85a** are each soldered to the corresponding signal line connecting lands **15a** through **15n** and the grounding contact piece land **14** on the front face **11a** of the wiring board **11**, and further, the signal core lines **81** and the shields **83** of the coaxial lines **85b** are each soldered to the corresponding signal line connecting lands **15'a** through **15'n** and the grounding contact piece land **14'** on the back face **11b** of the wiring board **11**, and are thus electrically connected.

[0097] The cable connector **40** that is electrically connected to the ultrasonic signal cable **67** is inserted from the distal end side of the endoscope insertion unit **71** (see FIG. 1), and passes through to extend to the ultrasonic connector **68**. The connector receptacle **41** is provided on the connecting connector **102** of the ultrasonic connector **68**, and is

attached to the recessed portion **42** of the connector receptacle **41** from the back face **11b** side of the wiring board **11** of the cable connector **40**.

[0098] At this time, the first and second positioning shafts **45a** and **45b** provided on the recessed portion **42** are passed through the first and second positioning holes **27a** and **27b** provided on the cable connector **40**, and the cable connector **40** is attached to the connector receptacle **41**. When the position of the cable connector **40** is determined by the first and second positioning shafts **45a** and **45b** and attached to the recessed portion **42** of the connector receptacle **41**, the contact piece lands **18'a** through **18'n** and the grounding contact piece lands **19'a** and **19'b** provided on the back face **11b** side of the wiring board **11** electrically connect to the corresponding contact point lands **43a** through **43n** and the grounding contact point lands **44a** and **44b** of the recessed portion **42**.

[0099] When the cable connector **40** is attached to the recessed portion **42** of the connector receptacle **41**, the first through third positioning holes **56a** through **56c** of the connecting board **51** are each inserted into the first through third positioning shafts **45a** through **45c** of the connector receptacle **41**. Then, one face of the connecting board **51** is positioned on the connector receptacle **41** so as to face the plane portion **47** of the connector receptacle **41** and the front face **11a** of the wiring board **11** of the cable connector **40** that is attached to the recessed portion **42**.

[0100] In other words, when the connecting board **51** is positioned on the connector receptacle **41**, the third contact point lands **52a** through **52n** and the grounding contact point lands **53a** and **53b** make contact with the corresponding contact piece lands **18a** through **18n** and the grounding contact piece lands **19a** and **19b** provided on the front face **11a** of the wiring board **11**.

[0101] Further, the fourth contact point lands **52'a** through **52'n** and the grounding contact point lands **53'a** and **53'b** on the connecting board **51** make contact with the corresponding second contact point lands **48a** through **48n** and the grounding contact point lands **49a** and **49b** provided on the plane portion **47** of the connector receptacle **41**. In this state, the connecting board **51** is fixed to the connector receptacle **41** by means of the external thread screws **58a** and **58b** passing through the screw openings **57a** and **57b**, and screwing the connecting board **51** in place to the attaching screw holes **46a** and **46b** of the connector receptacle **41**.

[0102] Thus, the contact piece lands **18a** through **18n** and **18'a** through **18'n** and the grounding lands **19a**, **19b**, **19'a**, and **19'b** provided on the two sides **11a** and **11b** of the wiring board **11** of the cable connector **40** are electrically connected to the matching board **101** via the connector receptacle **41** and the connecting board **51**.

[0103] Accordingly, the cable connector **40** can be made with a smaller sideways width because of the multiple signal core lines **81** of the ultrasonic signal cable **67** being capable of connecting to both sides. Therefore, insertion of the endoscope insertion portion **62** into the ultrasonic signal cable channel can be greatly improved. Further, the endoscope insertion portion **62** itself can have a smaller diameter because the ultrasonic signal cable channel of the endoscope insertion portion **62** has a smaller diameter.

[0104] Further, the cable connector **40** can have fewer connectors to the ultrasonic signal cable **67** because the

many signal core lines **81** of the ultrasonic signal cable **67** are connected to the two faces **11a** and **11b** of the wiring board **11** of the cable connector **40**, and the insertion operation into the ultrasonic signal cable channel becomes easier.

[0105] Further, the cable connector **40** is easily connected to the ultrasonic connector **68** by being sandwiched between the connector receptacle **41** and the connecting board **51**, wherein the connector receptacle **41** overlaps and attaches the cable connector **40** with the ultrasonic connector **68**. In particular, since no soldering work is necessary for the connection between the cable connector **40** and the ultrasonic connector **68**, attaching the cable connector **40** to the ultrasonic connector **68** can be performed more efficiently.

Third Embodiment

[0106] Next, the ultrasonic signal cable connector device relating to the present invention will be described with reference to **FIGS. 17 and 18**.

[0107] **FIG. 17** is a front view illustrating the configuration of the ultrasonic signal cable connector device relating to the third embodiment of the present invention, and **FIG. 18** is a back view illustrating the configuration of the ultrasonic signal cable connector device according to the third embodiment of the present invention.

[0108] The cable connector **60** of the present embodiment is provided with multiple signal line connecting lands **62a** through **62n** and **62'a** through **62'n** and two grounding lands, one on each face, **63** and **63'** that are electrically connected by soldering the shield **83** and the signal core line **81** of the ultrasonic signal cable **67** to both the front and back faces of the cable connecting portion **12'** of the wiring board **61** that is formed in a rectangular shape, similar to the above-described second embodiment.

[0109] The connector connecting unit **13'** of one face (hereafter may be referred to as "front face") **61a** of the wiring board **61** of the cable connector **60** is provided with multiple grounding patterns, two to be specific, **64a** and **64b** that extend from both ends of the connecting land **63** of the cable connecting portion **12'**, and multiple wiring patterns **79** that each extends from the multiple signal line connecting lands **62a** through **62n**, and two grounding contact piece lands **65a** and **65b** that each connects to the grounding patterns **64a** and **64b**, and multiple contact piece lands **66a** through **66n** that each connects to the wiring patterns **79**, and multiple grounding contact piece lands that have a through hole (hereafter referred to as "grounding contact piece land with through hole") **65c** and **65d**, and multiple contact piece lands that have a through hole (hereafter referred to as "contact piece land with through hole") **67a** through **67n**.

[0110] The wiring patterns **79** are formed with predetermined spacing that is approximately equal to the right and left thereof, towards the center shaft in the lengthwise direction of the wiring board **61** that is in a rectangular shape on the front face **61a** of the wiring board **61**. The grounding contact piece lands **65a** and **65b** and the contact piece lands **66a** through **66n** are formed in approximately the same shape and size, and positioned with equal spacing, along both long edges of the rectangular shaped wiring board **61** on the front face **61a** of the wiring board **61**.

[0111] The two grounding contact piece lands with through holes **65c** and **65d**, and the multiple contact piece

lands with through holes **67a** through **67n**, are formed in approximately the same shape as the two grounding lands **64a** and **64b**, and the multiple contact piece lands **66a** through **66n**, and are each positioned between the grounding lands **64a** and **64b**, and the contact piece lands **66a** through **66n**.

[0112] As illustrated in **FIG. 18**, the connector connecting unit **13'** of the other face (hereafter may be referred to as "back face") **61b** of the wiring board **61** of the cable connector **60** is provided with multiple grounding patterns, two to be specific, **64'a** and **64'b** that extend from both ends of the connecting land **63'** of the cable connecting portion **12'**, and multiple wiring patterns **79'** that each extends from the signal line connecting lands **62'a** through **62'n**, and multiple grounding through holes, two to be specific, **65'c** and **65'd** that each connects to the two grounding patterns **64'a** and **64'b**, and multiple through holes **67'a** through **67'n** that are each connected to the multiple wiring patterns **79'**.

[0113] The wiring patterns **79'** are formed with predetermined spacing that is approximately equal to the right and left thereof, towards the center shaft in the lengthwise direction of the wiring board **61a** that is in a rectangular shape on the back face **61b** of the wiring board **61**. The grounding through holes **65'c** and **65'd** and the through holes **67'a** through **67'n** are each electrically connected to the grounding contact piece lands with through holes **65c** and **65d** and the contact piece lands with through holes **67a** through **67n** that are provided on the front face **61a** of the wiring board **61**.

[0114] In other words, the cable connector **60** is arranged such that the multiple signal line connecting lands **62a** through **62n** and **62'a** through **62'n** and the two grounding contact piece lands **63** and **63'** formed on the front and back faces **61a** and **61b** of the cable connecting portion **12'** of the wiring board **61** can connect to the corresponding multiple signal core lines **81** and the multiple shields **83** of the ultrasonic signal cable **67**. The multiple signal core lines **81** and the multiple shields **83** of the ultrasonic signal cable **67** connected to the front face **61a** of the wiring board **61** of the cable connector **60** are connected to the corresponding grounding contact piece lands **65a** and **65b** and the connecting contact piece lands **66a** through **66n** via the grounding patterns **64a** and **64b** and the wiring patterns **65a** through **65n**.

[0115] Further, the multiple signal core lines **81** and the multiple shields **83** of the ultrasonic signal cable **67** connected to the back face **61b** of the wiring board **61** are connected to the corresponding grounding through holes **65'c** and **65'd** and the through holes **67'a** through **67'n** via the grounding patterns **64'a** and **64'b** and the wiring patterns **79'**.

[0116] In other words, the multiple signal core lines **81** and the multiple shields **83** of the ultrasonic signal cable **67** connected to the back face **61b** of the wiring board **61** are electrically connected to the corresponding grounding contact piece lands with through hole **65c** and **65d** and the contact piece lands with through hole **66a** through **66n** provided on the front face **61a** of the wiring board **61**, via the grounding through holes **65'c** and **65'd** and the through holes **67'a** through **67'n**.

[0117] Therefore, the cable connector **60** enables the cable connecting portion **12'** to connect the signal core lines **81** and

the shields **83** of the ultrasonic signal cable **67** to the two faces **61a** and **61b** of the wiring board **61**, and the multiple contact piece lands **65a** through **65d** and **66a** through **66n** and **67a** through **67n** that are connected to the ultrasonic connector **68** are provided on one face. The multiple signal core lines **81** and the shields **83** connected to the back face **61b** of the wiring board **61** are electrically connected to the corresponding contact piece lands **65c** and **65d** and **67a** through **67n** provided on the front face **61a** of the wiring board **61**, via each of the through holes **65'c**, **65'd**, and **67'a** through **67'n**.

[0118] Note that, contact point lands are formed on the connector receptacle **41** for connecting the above-described cable connector **60** to the ultrasonic connector **68** which can make connection facing the corresponding grounding contact piece lands **65a** through **65d**, the contact piece lands **66a** through **66n**, and the contact piece lands with through hole **67a** through **67n** of the connector connecting unit **13'** of the cable connector **60**. Thus, the cable connector **60** easily connects to the ultrasonic connector **68**.

[0119] As described above, the ultrasonic signal cable connector device according to the present invention can be formed so as to be capable of passing through the ultrasonic cable channel of an endoscope and so forth, and can be connected to the ultrasonic connector without necessitating soldering work.

[0120] Having described the preferred embodiments of the invention referring to the accompanying drawings, it should be understood that the present invention is not limited to those precise embodiments and various changes and modifications thereof could be made by one skilled in the art without departing from the spirit or scope of the invention as defined in the appended claims.

What is claimed is:

1. An ultrasonic signal cable connector device to be used with

an ultrasonic endoscope device comprising

an ultrasonic endoscope having an electronic scanning ultrasonic transducer provided on a distal end of an insertion portion to be inserted in the body cavity, for generating ultrasonic wave to the living-body tissue cavity and receiving the ultrasonic wave reflected from the body cavity tissue so as to generate ultrasonic signals, and

ultrasonic measuring equipment for performing driving control of the ultrasonic transducer of the ultrasonic endoscope and generating ultrasonic image signals from the sent ultrasonic signal

the ultrasonic signal cable connector device comprising:

an ultrasonic signal cable having a plurality of signal lines connected to the electronic scanning ultrasonic transducer;

an ultrasonic connector for connecting the ultrasonic signal cable to the ultrasonic measuring equipment;

a rectangular wiring board that has approximately the same or smaller width dimension as the external diameter of the ultrasonic signal cable;

a plurality of signal line connecting lands arrayed in parallel on the surface of one of the short sides of the wiring board for electrically connecting the plurality of signal lines of the ultrasonic signal cable;

a plurality of contact piece lands arrayed in a column longitudinally on the surface of the wiring board for electrically connecting the plurality of connecting connector pieces provided to the ultrasonic connector; and

a plurality of wiring patterns for connecting the plurality of signal line connecting lands and contact piece lands that are provided on the surface of the wiring board.

2. An ultrasonic signal cable connector device according to claim 1, wherein the plurality of signal line connecting lands, contact piece lands, and wiring patterns are provided on both the front and back surfaces of the wiring board.

3. An ultrasonic signal cable connector device according to claim 1, wherein the plurality of signal line connecting lands are arrayed in parallel on the front and back surfaces of one of the short sides of the wiring board, the plurality of contact piece lands are positioned in columns on both long sides on the surface of the wiring board, and the signal line connecting lands provided on the back surface of the wiring board are connected to the contact piece lands via through holes.

4. An ultrasonic signal cable connector device according to claim 1, the ultrasonic connector comprising:

a plurality of contact point lands to be clamped to the plurality of contact piece lands of the wiring board; and

a connector receptacle that extends from the contact point lands and has a plurality of connecting patterns for connecting to a plurality of connector pins, for connecting to the ultrasonic measuring equipment.

5. An ultrasonic signal cable connector device according to claim 2, the ultrasonic connector comprising:

a plurality of contact point lands to be clamped to the plurality of contact piece lands of the wiring board; and

a connector receptacle that extends from the contact point lands and has a plurality of connecting patterns for connecting to a plurality of connector pins, for connecting to the ultrasonic measuring equipment.

6. An ultrasonic signal cable connector device according to claim 3, the ultrasonic connector comprising:

a plurality of contact point lands to be clamped to the plurality of contact piece lands of the wiring board; and

a connector receptacle that extends from the contact point lands and has a plurality of connecting patterns for connecting to a plurality of connector pins, for connecting to the ultrasonic measuring equipment.

7. An ultrasonic signal cable connector device according to claim 2, the ultrasonic connector comprising:

a connector receptacle having

a first contact point land that is connected to the contact piece land provided on one face of the wiring board, and

a second contact point land disposed alongside the first contact point land; and

- a connecting board having
 - a third contact point land connected to the contact piece land provided on the other face of the wiring board,
 - a fourth contact point land connected to the second contact point land of the connector receptacle, and
 - a wiring pattern that connects the third and fourth contact point lands.
- 8.** An ultrasonic signal cable connector device according to claim 4, the ultrasonic connector comprising:
 - a connector receptacle having
 - a first contact point land that is connected to the contact piece land provided on one face of the wiring board, and
 - a second contact point land disposed alongside the first contact point land; and
 - a connecting board having
 - a third contact point land connected to the contact piece land provided on the other face of the wiring board,
 - a fourth contact point land connected to the second contact point land of the connector receptacle, and
 - a wiring pattern that connects the third and fourth contact point lands.
- 9.** An ultrasonic endoscope comprising:
 - an ultrasonic transducer provided on a distal end of an insertion portion to be inserted in the body cavity, for generating ultrasonic wave to the tissue of the body cavity and receiving the ultrasonic wave reflected from the body cavity tissue so as to generate an ultrasonic signal;
 - an ultrasonic signal cable having a plurality of signal lines wherein one end is connected to a plurality of piezoelectric elements making up the ultrasonic transducer, and the other end is connected to the ultrasonic signal cable connector device; and
 - an ultrasonic connector device connected to the ultrasonic signal cable and connected to the ultrasonic measuring equipment;
 - the ultrasonic signal cable connector device comprising:
 - a rectangular wiring board that has approximately the same or smaller width dimension as the external diameter of the ultrasonic signal cable;
 - a plurality of signal line connecting lands arrayed in parallel on the surface of one of the short sides of the wiring board for electrically connecting the plurality of signal lines of the ultrasonic signal cable;
 - a plurality of contact piece lands arrayed in a column longitudinally on the surface of the wiring board for electrically connecting the plurality of connecting connector pieces provided to the ultrasonic connector; and
 - a plurality of wiring patterns for connecting the plurality of signal line connecting lands and contact piece lands that are provided on the surface of the wiring board.
- 10.** An ultrasonic endoscope according to claim 9, wherein the plurality of signal line connecting lands, contact

piece lands, and wiring patterns are provided on both the front and back surfaces of the wiring board.

11. An ultrasonic endoscope according to claim 9, wherein the plurality of signal line connecting lands are arrayed in parallel on the front and back surfaces of one of the short sides of the wiring board, the plurality of contact piece lands are positioned in columns on the front surface of the wiring board of both long sides of the wiring board, and the signal line connecting lands provided on the back surface of the wiring board are connected to the contact piece lands via through holes.

12. An ultrasonic endoscope according to claim 9, the ultrasonic connector comprising:

- a plurality of contact point lands to be clamped to the plurality of contact piece lands of the wiring board; and

- a connector receptacle that extends from the contact point lands and has a plurality of connecting patterns for connecting to a plurality of connector pins, for connecting to the ultrasonic measuring equipment.

13. An ultrasonic endoscope according to claim 10, the ultrasonic connector comprising:

- a plurality of contact point lands to be clamped to the plurality of contact piece lands of the wiring board; and

- a connector receptacle that extends from the contact point lands and has a plurality of connecting patterns for connecting to a plurality of connector pins, for connecting to the ultrasonic measuring equipment.

14. An ultrasonic endoscope according to claim 11, the ultrasonic connector comprising:

- a plurality of contact point lands to be clamped to the plurality of contact piece lands of the wiring board; and

- a connector receptacle that extends from the contact point lands and has a plurality of connecting patterns for connecting to a plurality of connector pins, for connecting to the ultrasonic measuring equipment.

15. An ultrasonic endoscope according to claim 10, the ultrasonic connector comprising:

- a connector receptacle having

- a first contact point land that is connected to the contact piece land provided on one face of the wiring board, and

- a second contact point land disposed alongside the first contact point land; and

- a connecting board having

- a third contact point land connected to the contact piece land provided on the other face of the wiring board,

- a fourth contact point land connected to the second contact point land of the connector receptacle, and

- a wiring pattern that connects the third and fourth contact point lands.

16. An ultrasonic endoscope according to claim 13, the ultrasonic connector comprising:

- a connector receptacle having

- a first contact point land that is connected to the contact piece land provided on one face of the wiring board, and

a second contact point land disposed alongside the first contact point land; and
a connecting board having
a third contact point land connected to the contact piece land provided on the other face of the wiring board,

a fourth contact point land connected to the second contact point land of the connector receptacle, and
a wiring pattern that connects the third and fourth contact point lands.

* * * * *

专利名称(译)	超声波内窥镜和超声波信号线连接器装置		
公开(公告)号	US20050143658A1	公开(公告)日	2005-06-30
申请号	US11/018248	申请日	2004-12-21
[标]申请(专利权)人(译)	奥林巴斯株式会社		
申请(专利权)人(译)	OLYMPUS CORPORATION		
[标]发明人	SAIGA KAZUYA		
发明人	SAIGA, KAZUYA		
IPC分类号	A61B1/00 A61B8/12 H01R9/05 A61B8/14		
CPC分类号	A61B1/00114 A61B8/4488 A61B8/12		
优先权	2003435623 2003-12-26 JP		
外部链接	Espacenet USPTO		

摘要(译)

一种超声波信号线连接器装置，与超声波内窥镜装置一起使用，该超声波内窥镜装置包括具有电子扫描超声波换能器和超声波测量设备的超声波内窥镜，包超声波连接器，用于将超声波信号电缆连接到超声波测量设备；矩形布线板，其宽度与超声波信号电缆的外径大致相同或更小；信号线连接在布线板的一个短边的表面上平行排列的焊盘，用于电连接超声波信号电缆的信号线；接线片焊盘纵向排列在布线板表面上的一列中，用于电连接超声波连接器的连接件；用于连接连接焊盘和接触片焊盘的信号线的布线图案在布线板的表面上。

