



US006514210B2

(12) **United States Patent**  
**Ohara et al.**

(10) **Patent No.:** **US 6,514,210 B2**  
(45) **Date of Patent:** **Feb. 4, 2003**

(54) **FORWARD VIEWING AND RADIAL SCANNING ULTRASONIC ENDOSCOPE**

5,873,828 A \* 2/1999 Fujio et al. .... 600/439  
6,095,970 A 8/2000 Hidaka et al.  
6,193,666 B1 \* 2/2001 Ouchi ..... 600/459

(75) Inventors: **Kenichi Ohara**, Gunma (JP);  
**Toshiyuki Hashiyama**, Saitama (JP)

**FOREIGN PATENT DOCUMENTS**

(73) Assignee: **Pentax Corporation**, Tokyo (JP)

JP 2-265534 10/1990

(\*) Notice: Subject to any disclaimer, the term of this patent is extended or adjusted under 35 U.S.C. 154(b) by 0 days.

\* cited by examiner

(21) Appl. No.: **09/850,225**

*Primary Examiner*—Marvin M. Lateef

(22) Filed: **May 8, 2001**

*Assistant Examiner*—Ruby Jain

(65) **Prior Publication Data**

(74) *Attorney, Agent, or Firm*—Greenblum & Bernstein, P.L.C.

US 2001/0041839 A1 Nov. 15, 2001

(30) **Foreign Application Priority Data**

(57) **ABSTRACT**

May 10, 2000 (JP) ..... 2000-136733

(51) **Int. Cl.**<sup>7</sup> ..... **A61B 8/12**

(52) **U.S. Cl.** ..... **600/462; 600/463**

(58) **Field of Search** ..... 600/462, 459, 600/463, 439, 160, 423, 445, 116, 431, 156, 440; 348/75

In a radial scan, forward viewing ultrasonic endoscope, centering mating portions that permit the outer surface of an ultrasonic probe and the outer surface of a tip body to meet flush with each other at the boundary are formed in the ultrasonic probe and in the tip body and the gap between the inner peripheral surface of the ultrasonic probe and the mating surface of the front half of the tip body is formed to be larger than the gap between the centering mating portions.

(56) **References Cited**

**U.S. PATENT DOCUMENTS**

4,998,182 A \* 3/1991 Krauter et al. .... 348/75

**24 Claims, 11 Drawing Sheets**

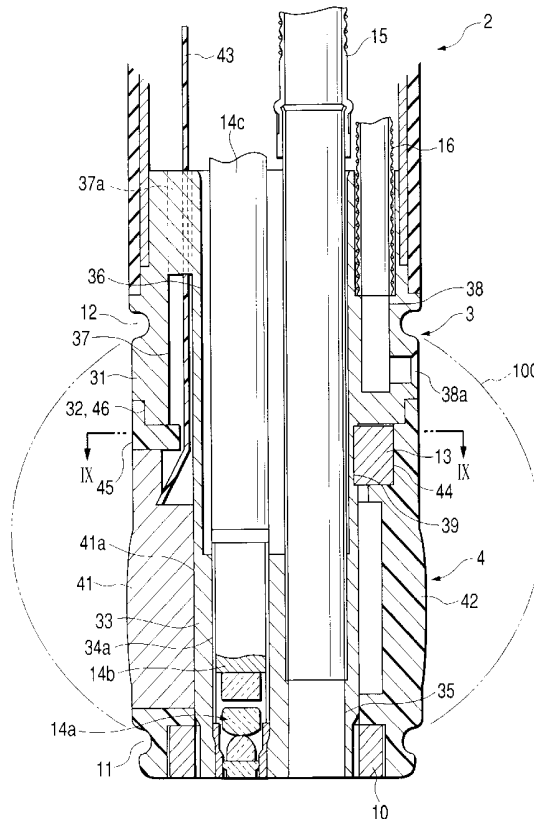

FIG. 1

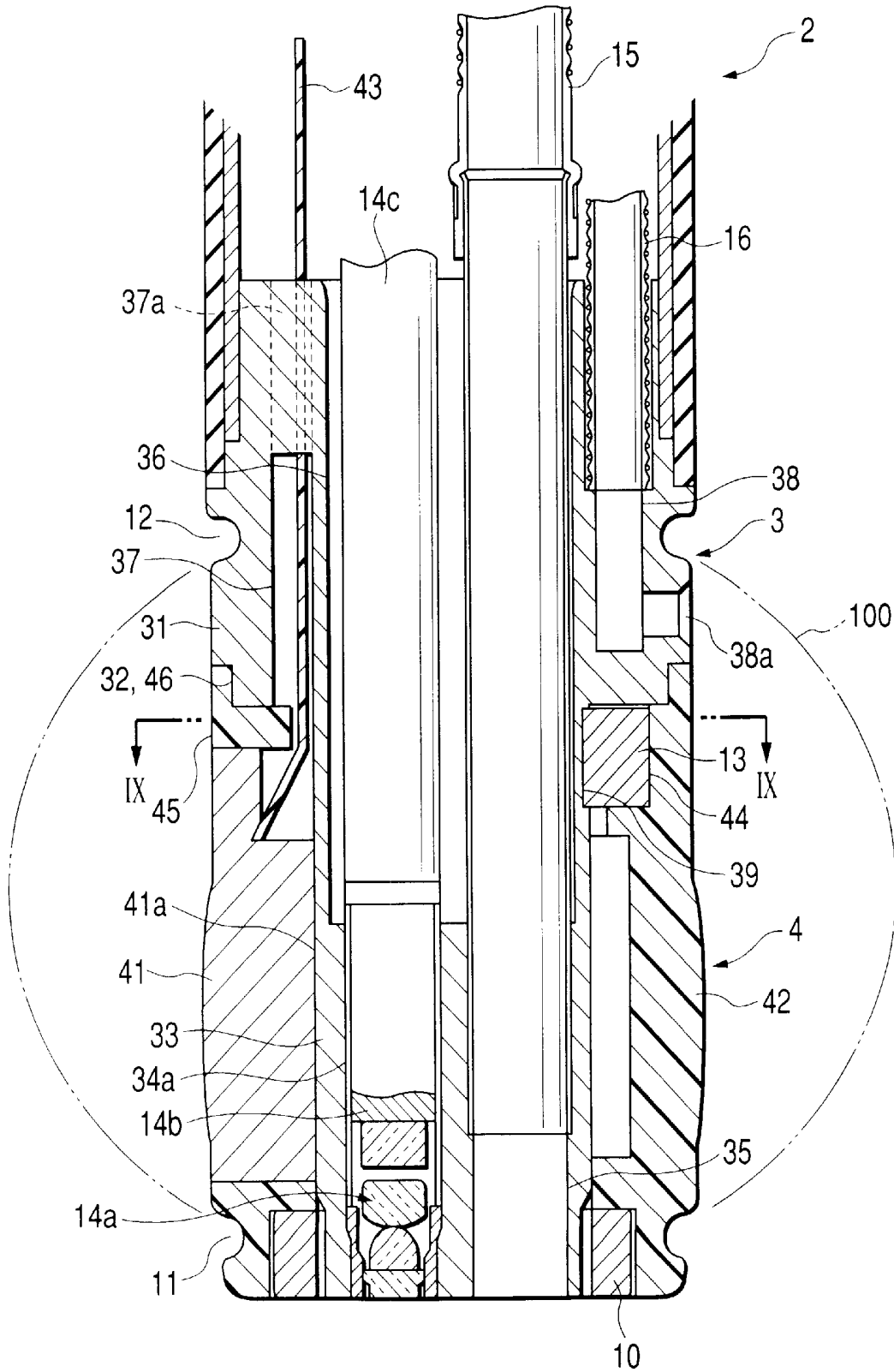



FIG. 3

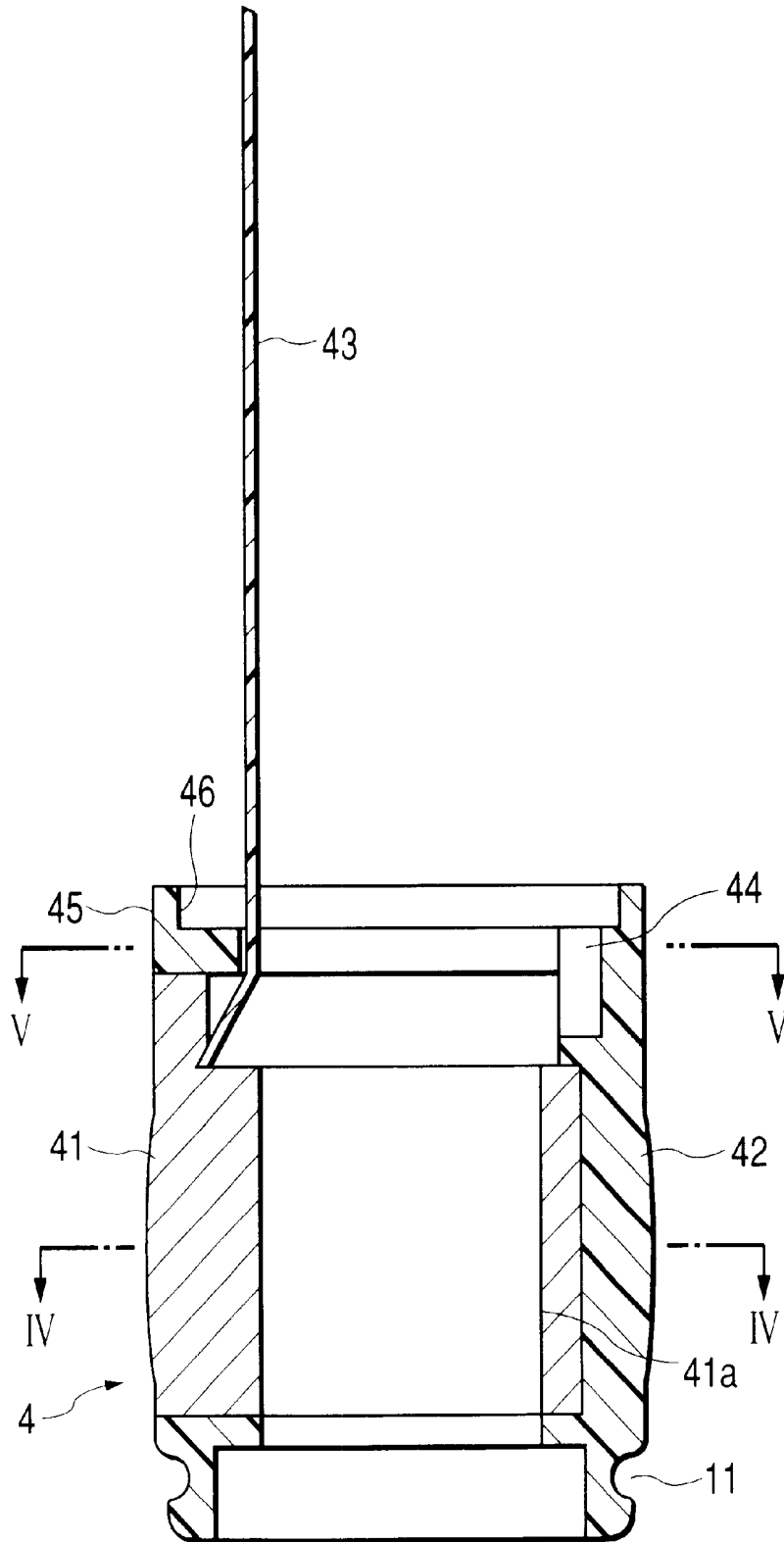
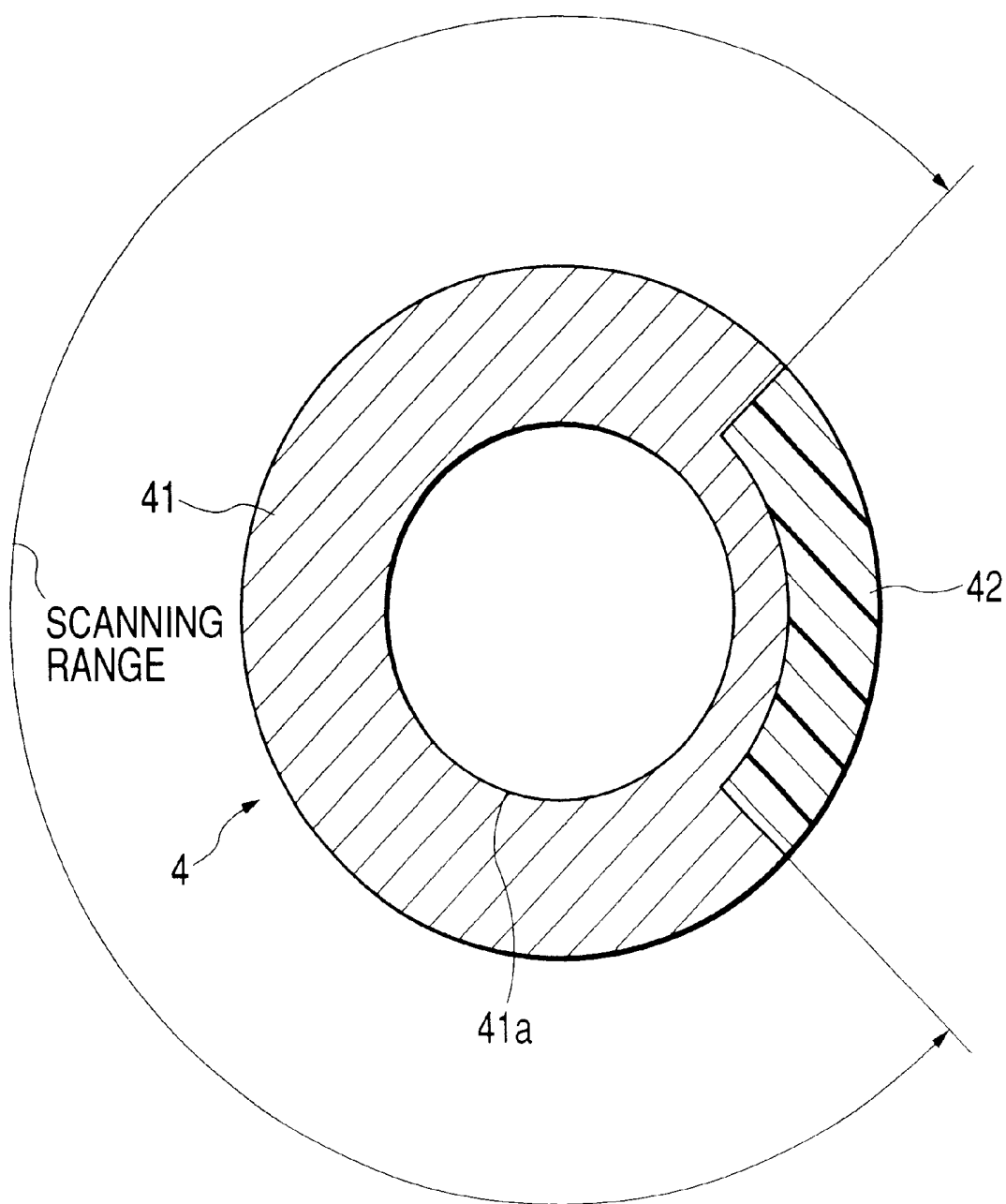

FIG. 4



*FIG. 5*

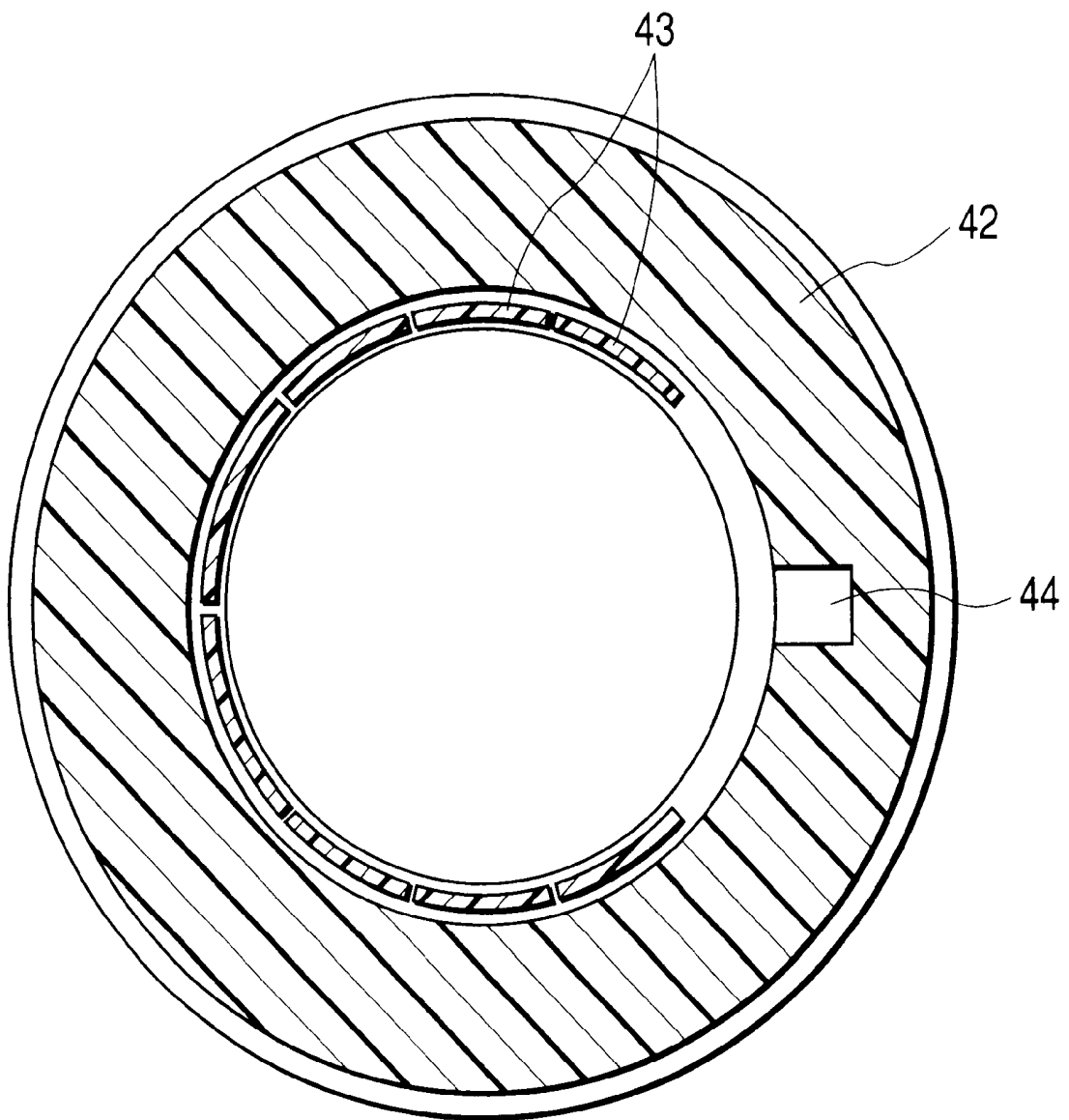
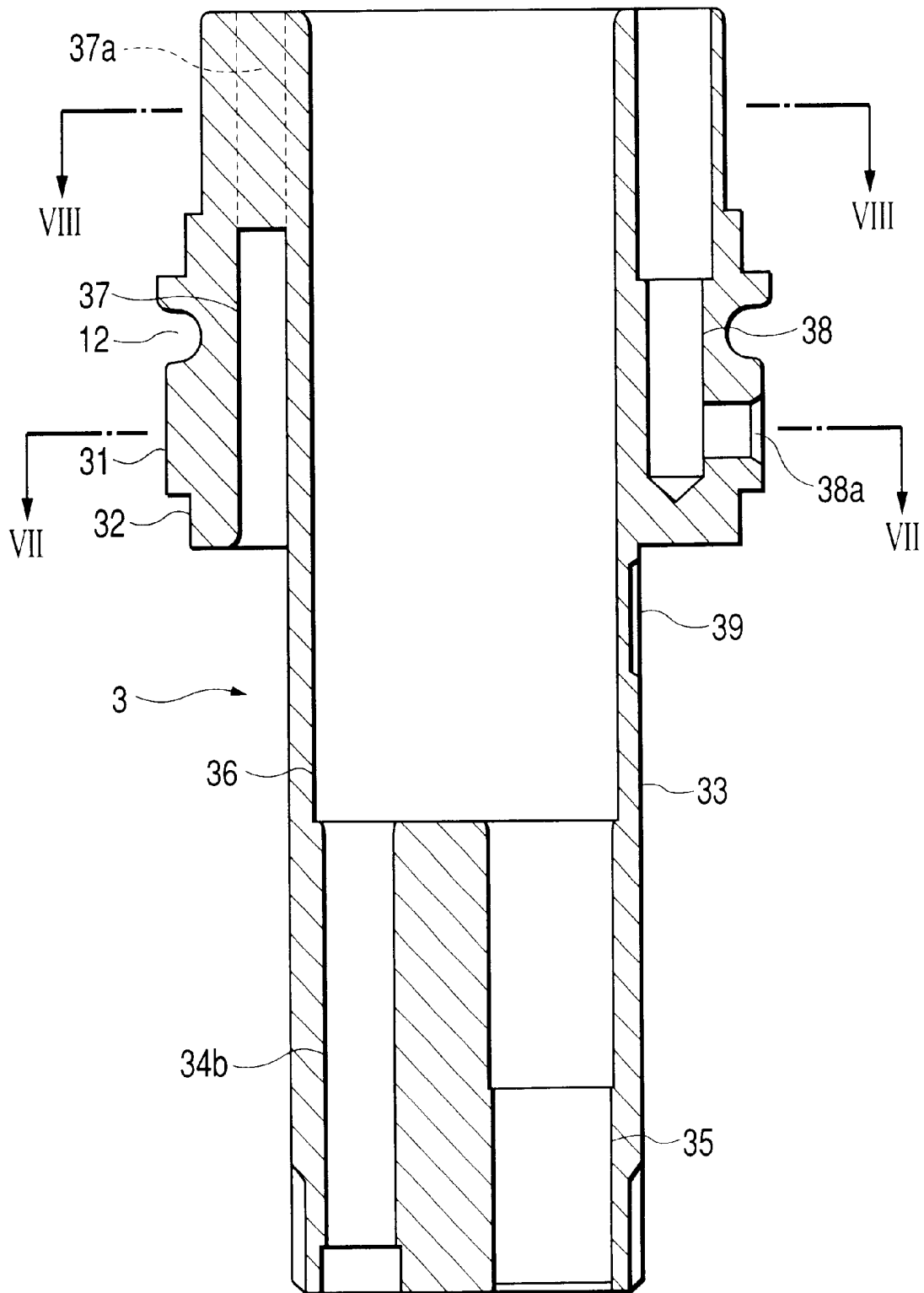
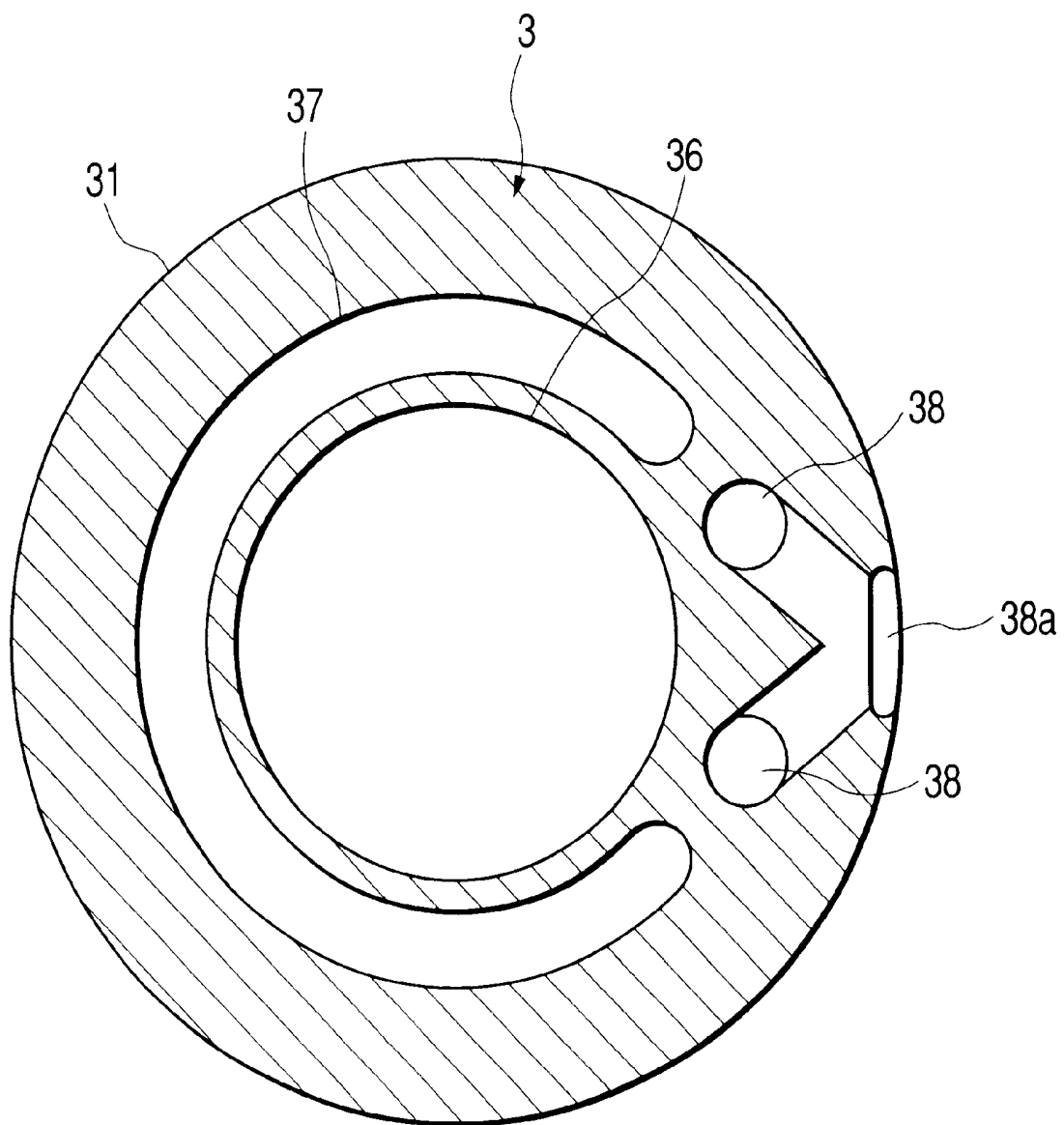

FIG. 6



*FIG. 7*



**FIG. 8**

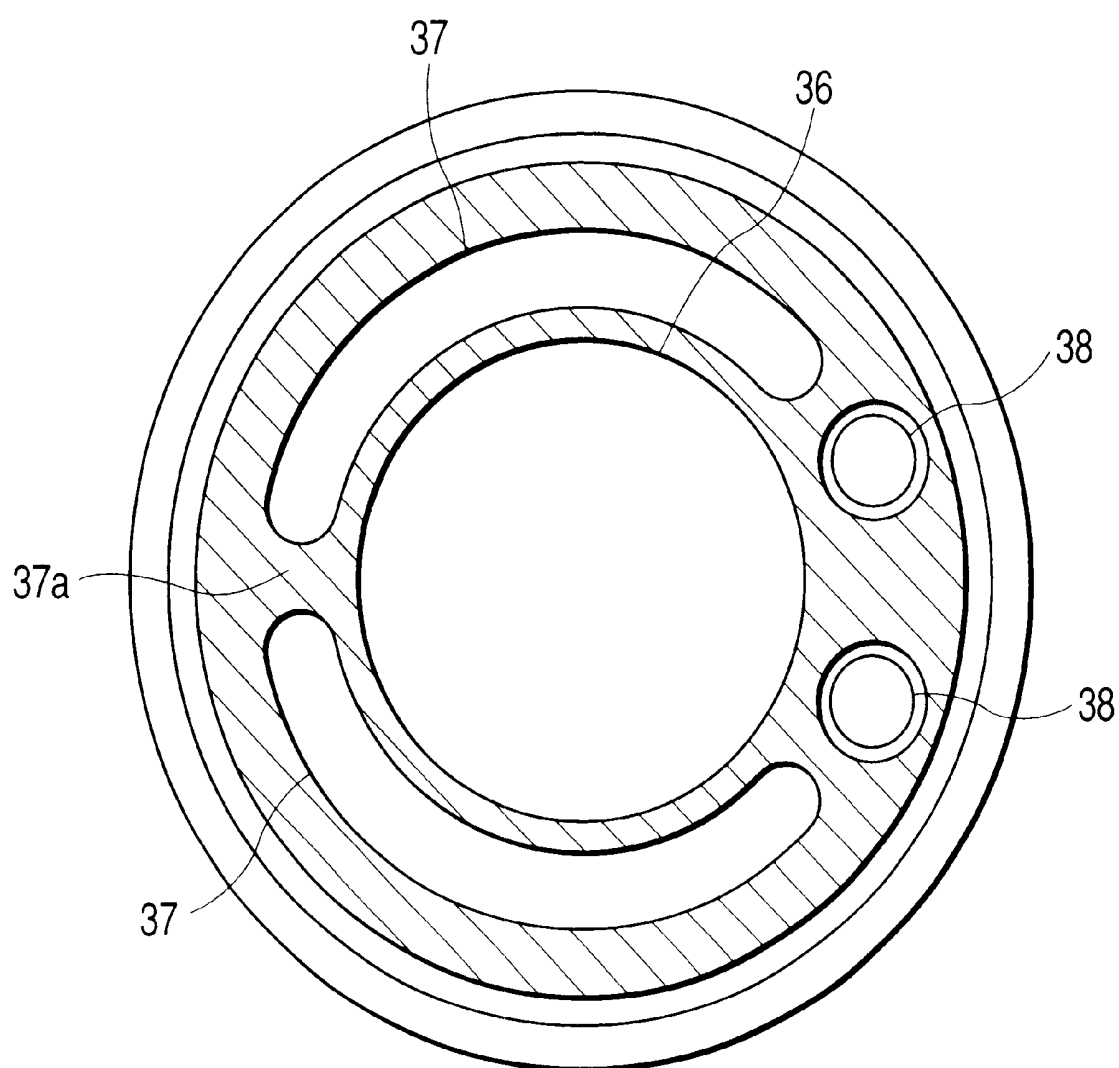



*FIG. 10*

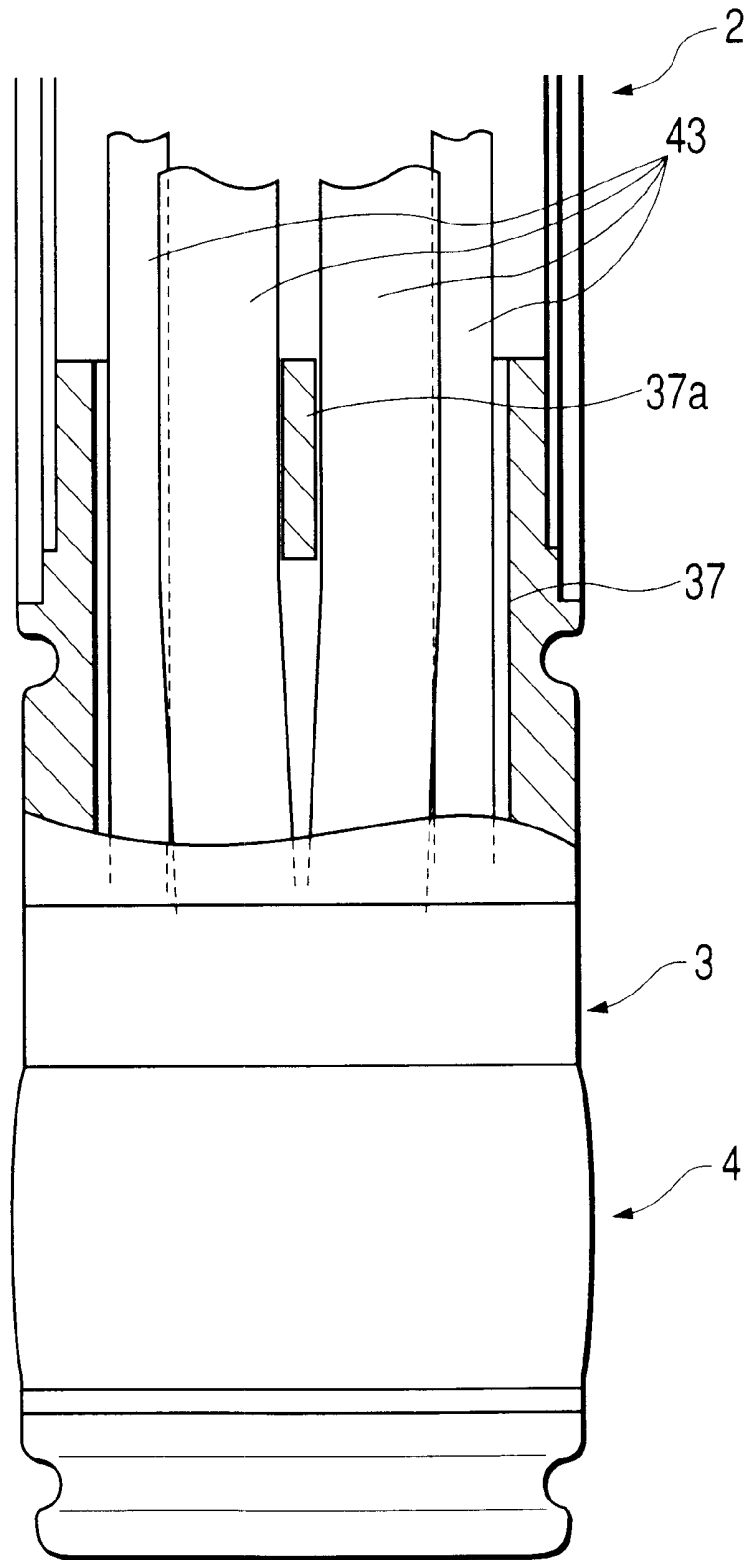

FIG. 11

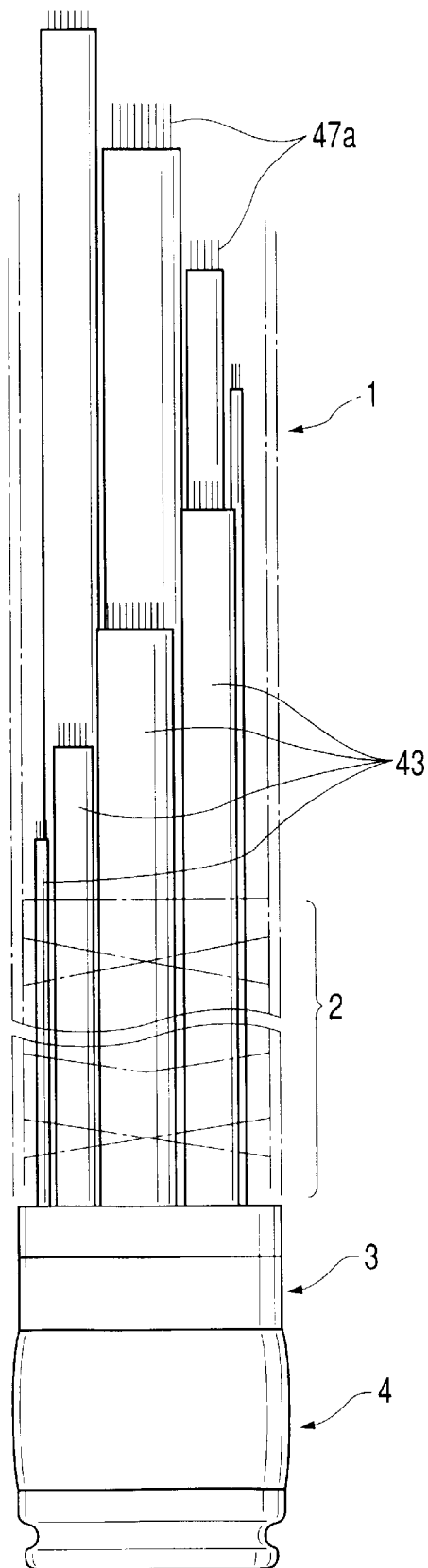
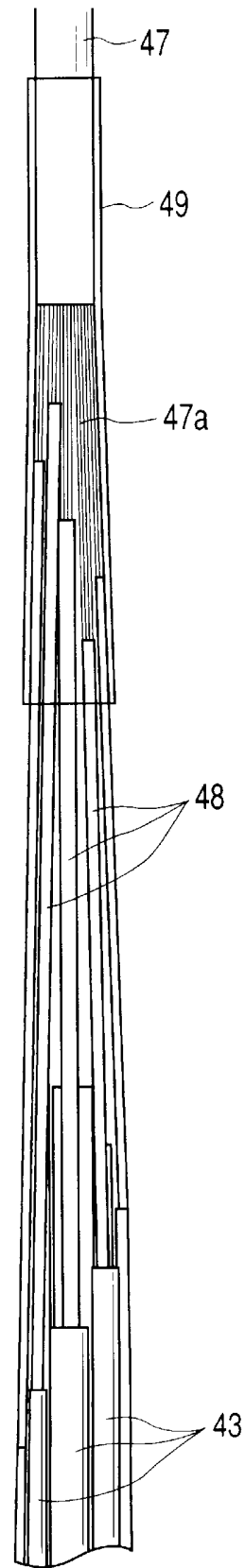

FIG. 12



## FORWARD VIEWING AND RADIAL SCANNING ULTRASONIC ENDOSCOPE

### BACKGROUND OF THE INVENTION

The present invention relates to a radial scan, forward viewing ultrasonic endoscope having, at the tip of an insertion portion, objective optics for optical examination of the area ahead of said insertion portion and an ultrasonic probe for performing radial scan by ultrasound.

For ultrasonic endoscopes that can optically examine a body cavity while performing ultrasonic scan, it is generally considered advisable to project ultrasonic waves from the tip of an insertion portion to perform lateral scan on the area which lies the nearest to the scanning direction to be examined optically. The conventional ultrasonic endoscopes are structurally designed to meet this requirement.

However, the greatest value of ultrasonic endoscopes lies in inserting the ultrasonic endoscope into an accessible organ adjacent to the inaccessible organ which has problems and performing ultrasonic scan from the accessible organ by obtaining an ultrasonic cross-sectional image of the other side of an abnormal area of the mucous membrane in the body cavity of interest.

Therefore, effective ultrasonic scan is in most cases radial scan about the longitudinal axis of the tip of the insertion portion whereas effective optical examination is forward viewing which is most convenient for checking the area ahead of the insertion portion of the endoscope as it passes through the body cavity.

However, ultrasonic endoscopes of this type that are commonly called "radial scan, forward viewing ultrasonic endoscopes" have several problems to solve, such as designing a structure that can shorten the rigid tip, and no commercial product has been put on the market.

### SUMMARY OF THE INVENTION

An object, therefore, of the present invention is to provide a practically feasible radial scan, forward viewing ultrasonic endoscope that can minimize the length of the rigid tip of the insertion portion.

This object of the invention can be attained by a radial scan, forward viewing ultrasonic endoscope having an ultrasonic probe that is formed in annular shape to perform radial scan and which is provided at the tip of an insertion portion and a tip body that is fitted with objective optics for examining the area ahead of the insertion portion and that has a smaller outside diameter in the front half which is fitted into the ultrasonic probe, characterized in that centering mating portions that permit the outer surface of the ultrasonic probe and that of the tip body to meet flush with each other at the boundary are formed in the ultrasonic probe and in the tip body, and that the gap between the inner peripheral surface of the ultrasonic probe and the mating surface of the front half of the tip body is formed to be larger than the gap between the centering mating portions.

In a preferred embodiment, the ultrasonic probe has an array of ultrasonic vibrators and an annular receptacle for holding the array of ultrasonic vibrators, the front half of the tip body is fitted into the internal space of the array of ultrasonic vibrators, and the centering mating portions are formed in the receptacle.

The present disclosure relates to the subject matter contained in Japanese patent application No. 2000-136733 (filed on May 10, 2000), which is expressly incorporated herein by reference in its entirety.

### BRIEF DESCRIPTION OF THE DRAWINGS

FIG. 1 is a longitudinal section of the tip of the insertion portion of a radial scan, forward viewing ultrasonic endoscope according to an example of the invention;

FIG. 2 is a side view showing the general layout of the radial scan, forward viewing ultrasonic endoscope;

FIG. 3 is a longitudinal section of the ultrasonic probe in the example;

FIG. 4 is section IV—IV of FIG. 3;

FIG. 5 is section IV—V of FIG. 3;

FIG. 6 is a longitudinal section of the tip body in the example;

FIG. 7 is section VII—VII of FIG. 6;

FIG. 8 is section VIII—VIII of FIG. 6;

FIG. 9 is section IX—IX of FIG. 1;

FIG. 10 is a partial sectional view showing how flexible boards pass through the bending portion in the example;

FIG. 11 is a sketch showing the ends of the flexible boards in the example; and

FIG. 12 is a side view of the area where the flexible boards are connected to the signal cable in the example.

### DESCRIPTION OF THE PREFERRED EMBODIMENT

An example of the present invention is described below with reference to the accompanying drawings.

FIG. 2 shows a radial scan, forward viewing ultrasonic endoscope. It comprises a flexible tube 1, a bending portion 2, a tip body 3 and an ultrasonic probe 4. The flexible tube 1 is to be inserted into a body cavity. The bending portion 2 is remotely manipulated to bend in various directions and coupled to the distal end of the flexible tube 1. The tip body 3 is coupled to the distal end of the bending portion 2. The ultrasonic probe 4 is fitted to the tip body 3. An inflatable balloon 100 is detachably provided around the ultrasonic probe 4.

A manipulating section 5 is coupled to the basal end of the flexible tube 1 and has knobs 6 for manipulating the bending portion 2 to bend in desired directions. Indicated by 7 is an opening through which a treatment tool or the like is inserted into a treatment tool insertion channel 15 extending through the flexible tube 1.

Two other flexible tubes 8 and 9 are coupled to the manipulating section 5. There are a video signal connector 81 which is connected to a video processor (not shown) and a lightguide connector 82 side by side at the distal end of the flexible tube 8. At the distal end of the flexible tube 9, there is an ultrasonic signal connector 91 which is connected to an ultrasonic signal processor (also not shown).

FIG. 1 shows the tip of the insertion portion. The ultrasonic probe 4 consists of a generally annular array of ultrasonic vibrators 41 that are held by a plastic receptacle 42 to form an united assembly (see FIG. 3).

As shown in FIG. 4 which is section IV—IV of FIG. 3, the array of ultrasonic vibrators 41 around the longitudinal axis of the insertion portion emit and receive ultrasonic signals successively (for electronic scan) through a certain angular range, say 270 degrees, around the longitudinal axis so as to perform radial scan in a direction perpendicular to the longitudinal axis.

The array of ultrasonic vibrators 41 has an internal space formed as a cylindrical hole centering on the longitudinal axis. Connected to the rear end of the array of ultrasonic

vibrators **41** (upward in FIG. **3**) are flexible boards **43** that are wired to transmit signals to and from the array of ultrasonic vibrators **41** and that extend rearward.

As shown in FIG. **5** which is section V—V of FIG. **3**, the flexible boards **43** comprising eight pieces in the example shown are arranged in arcs about the longitudinal axis of the ultrasonic probe **4**.

As is clear from FIG. **5**, the flexible boards **43** are arranged in arcs through an angle of, say, about 270 degrees and that area of an extension of the series of arcs where no flexible board is provided has a groove **44** into which an anti-rotation member **13** to be described later is to be fitted.

Turning back to FIG. **3**, the rear end portion of the receptacle **42** has a centering mating portion **46** that fits the centering mating portion **32** (to be described later) of the tip body **3** and which is formed in such a manner that it is concentric in high dimensional precision with the outer peripheral surface **45** (at the boundary where it meets the outer surface of the tip body **3**). At the tip of the receptacle **42**, a circumferential groove **11** is formed in the outer peripheral surface to assist in banding the distal end of the inflatable balloon **100**.

Turning back again to FIG. **1**, the tip body **3** typically made of plastics is so formed that the front half **33** has a size of small enough to fit the inner peripheral surface **41a** of the array of ultrasonic vibrators **41** in the ultrasonic probe **4**. The tip body **3** is shown as a single component in FIG. **6**. The outer peripheral surface **31** of the tip body **3** at the boundary where it meets the outer peripheral surface of the ultrasonic probe **4** is of the same size as the outer peripheral surface **45** of the ultrasonic probe **4**.

The front end portion of the tip body **3** has, on the outer peripheral surface **31**, the centering mating portion **32** that fits the centering mating portion **46** of the ultrasonic probe **4** and which is formed in such a manner that it is concentric in high dimensional precision with the outer peripheral surface **31**. At the rear end of the tip body **3**, a circumferential groove **12** is formed on the outer peripheral surface to assist in banding the rear end of the inflatable balloon **100**.

The front half **33** of the tip body **3** has an objective optics accommodating hole **34a**, an illumination light guide accommodating hole **34b** and a treatment tool passage hole **35** formed parallel to the longitudinal axis in the area closer to the foremost end. Backward of this area is formed as a cable accommodating hole **36** whose inside diameter is slightly smaller than the outside diameter of the front half **33** and which extends to the rear end of the tip body **3**.

The rear half of the tip body **3** has a flexible board passage hole **37** formed almost on an extension of the outer peripheral surface of the front half **33**. The flexible board passage hole **37** admits the passage of flexible boards **43** and as shown enlarged in FIG. **7** which is section VII—VII of FIG. **6**, it is formed in arc around the longitudinal axis with regard to the positions where the flexible boards **43** are arranged.

Note that in the area of the tip body **3** which is near its rear end, at least one link **37a** which interrupts the flexible board passage hole **37** part of the way is formed to secure the tip body **3** from being crushed under external force. This is shown enlarged in FIG. **8** which is section VIII—VIII of FIG. **6**.

Turning back to FIGS. **6** and **7**, the flexible board passage hole **37** is formed in arc through an angle of about 280 degrees. In the area which is an extension of the arc where no flexible board passage hole is formed, two fluid channels **38** through which deaerated water is injected into or drained from the balloon **100** are formed parallel to the longitudinal

axis such that they communicate with an opening **38a** into the balloon **100**.

The two fluid channels **38** are formed side by side and one of them is for exclusive use in exhausting air. Actually, the fluid channels **38** do not appear in FIG. **6** (and FIG. **1**) but for the sake of convenience in explanation, they are shown in those figures. Indicated by **39** is a groove into which the anti-rotation member **13** is to be fitted.

Turning back to FIG. **1**, the ultrasonic probe **4** fitted over the front half **33** of the tip body **3** is urged and fixed against the surface of the intermediate step in the tip body **3** by means of a nut member **10** that meshes with the male thread formed on the outer periphery of the distal end of the tip body **3**.

As shown enlarged in FIG. **9** which is section IX—IX of FIG. **1**, the anti-rotation member **13** in rectangular prism form is fitted into both the groove **44** in the ultrasonic probe **4** and the groove **39** in the tip body **3** so that the tip body **3** and the ultrasonic probe **4** do not rotate. This ensures that the direction of ultrasonic scan and the orientation of the viewing field for examination are set to satisfy the correct relationship. Indicated by **17** is a light guide fiber for illumination.

Turning back again to FIG. **1**, when the ultrasonic probe **4** is fixed to the tip body **3**, the front half **33** of the tip body **3** mates with the inner peripheral surface **41a** of the array of ultrasonic vibrators **41** and the centering mating portion **32** of the tip body **3** mates with the centering mating portion **46** of the ultrasonic probe **4**, because the gap in the former mating is formed to be larger than the gap between the mating portions in the latter case.

As a result, the seam between the tip body **3** and the ultrasonic probe **4** forms only a negligible difference in the exposed area where the outer peripheral surface **31** of the tip body **3** meets the outer peripheral surface **45** of the ultrasonic probe **4** and this contributes to forming an endoscope tip to be inserted smoothly into a body cavity of the patient.

Objective optics **14a** are provided in the distal end portion of the objective optics accommodating hole **34** and a solid-state imaging device **14b** is provided in the area behind them. A signal cable **14c** for transmitting imaging signals and so forth passes through the cable passage hole **36** to extend rearward into the bending portion **2**. The treatment tool insertion channel **15** is connected to the treatment tool passage hole **35** via a stainless steel pipe.

A flexible piping tube **16** is connected to each of the two fluid channels **38** and by operation of the manipulating section **5** and through these piping tubes **16**, deaerated water is injected into and drained from the balloon **100** fixed at opposite ends by the peripheral grooves **11** and **12** so as to inflate and deflate the balloon **100**.

As shown in FIG. **1**, the flexible boards **43** which transmit signals to and from the array of ultrasonic vibrators **41** pass through the flexible board passage hole **37** in the tip body **3** to be guided rearward into the bending portion **2**.

As is clear from FIG. **10**, in the latter half of the flexible board passage hole **37**, neighboring flexible boards **43** slightly overlap in order to avoid interference with the link **37a** before they are guided rearward into the bending portion **2**.

In the bending portion **2**, all signals that are supplied into and output from the array of ultrasonic vibrators **41** are transmitted via the wiring formed on the thin flexible boards **43** so that there is no need to pass a signal cable and the like through the bending portion **2**.

The flexible boards **43** are arranged in arcs that surround various inserts such as the signal cable **14c** or the solid-state imaging device **14b**, treatment tool insertion channel **15** and light-guide fiber **17**. Hence, the various inserts are passed through the bending portion **2** in such a manner as to maximize the utilization of its internal space and this helps reduce its diameter.

As FIG. **11** shows, the flexible boards **43** vary in length but even the shortest one is long enough to pass through the bending portion **2** so that within the flexible tube **1** through which a signal cable **47** is passed, the individual flexible boards **43** are connected in longitudinally offset positions to the tips of the respective signal lines **47a** in the cable **47**.

The signal lines **47a** in the cable **47** are soldered or otherwise connected to the flexible boards **43** and this can increase the diameter of each connection. However, in the present invention, the connections are longitudinally offset in position, so there is no possibility that their overall diameter unduly increases in certain areas and both the flexible tube **1** and the bending portion **2** can be formed in adequately small thickness.

FIG. **12** shows how the signal cable **47** is connected to the flexible boards **43** in the flexible tube **1**. The distal end of the signal cable **47** which is a bundle of numerous signal lines **47a** is disintegrated in the flexible tube **1** into individual signal lines **47a** and a given number of signal lines **47a** that are connected to each flexible board **43** are placed within a flexible heat-shrinking tube **48** which is subsequently shrunk to bind the encased signal lines together. This arrangement is effective to secure signal lines **47a** from being broken.

The respective heat-shrinking tubes **48** are arranged in the offset position of their end. With this design, the flexibility of the flexible tube **1** will not change abruptly and the change in its overall diameter is so sufficiently smooth that there will be no possibility that the tube diameter increases in certain areas. All of the connections under consideration are bundled together within a thicker heat-shrunk flexible tube **49**.

According to the invention, the gap between the inner peripheral surface of the ultrasonic tube and mating surface of the front half of the tip body is formed to be larger than the gap between the centering mating portions which enable the outer surfaces of the two members to be flush with each other at the boundary where they meet each other. As a result, the ultrasonic probe and the tip body can be coupled by a simple structural design without producing any differences and the rigid tip of the insertion portion is made as short as possible to fabricate an easily insertable and, hence, practically feasible radial scan, forward viewing ultrasonic endoscope.

What is claimed is:

**1.** A forward viewing and radial scanning ultrasonic endoscope comprising:

an ultrasonic probe formed in an annular shape for performing radial scanning, said ultrasonic probe being provided at a tip of an insertion portion of said endoscope; and

a tip body provided at the tip of said insertion portion of said endoscope, said tip body being fitted with objective optics for examining an area ahead of said insertion portion, a forward portion of said tip body having a smaller outside diameter than a rearward portion of said tip body, said forward portion of said tip body being configured so as to be fitted into said ultrasonic probe; wherein said ultrasonic probe and said tip body each include centering mating portions configured such that

an outer surface of said ultrasonic probe and an outer surface of said rearward portion of said tip body meet flush with each other at a boundary therebetween along an outer surface of the tip of said insertion portion, and so that a gap between an inner peripheral surface of said ultrasonic probe and an outer surface of said forward portion of said tip body is larger than a gap between said centering mating portions of said ultrasonic probe and said tip body.

**2.** The forward viewing and radial scanning ultrasonic endoscope according to claim **1**, wherein said ultrasonic probe includes an array of ultrasonic vibrators and an annular receptacle for holding the array of ultrasonic vibrators, said forward portion of said tip body being fitted into said array of ultrasonic vibrators and said centering mating portion of said ultrasonic probe being formed in said receptacle.

**3.** An ultrasonic endoscope comprising:

a tip body having a larger diameter portion, a smaller diameter portion located adjacent to the larger diameter portion to define an intermediate step surface between the larger and smaller diameter portions, and a thread formed on an end of the smaller diameter portion opposite from the larger diameter portion;

an ultrasonic probe, fitted on the smaller diameter portion, for performing radial scanning generally perpendicular to a longitudinal axis of said tip body; and

a nut member threadingly engaged with the thread to fixedly hold said ultrasonic probe between the intermediate step surface and said nut member.

**4.** The ultrasonic endoscope according to claim **3**, further comprising:

a treatment tool insertion channel passed through an interior of the smaller diameter portion of said tip body and an interior of said ultrasonic probe to enable access of a treatment tool to a tissue in a body cavity in front of said nut member;

an illumination system passed through the interior of the smaller diameter portion of said tip body and the interior of said ultrasonic probe to illuminate the tissue in the body cavity in front of said nut member; and

an observing system passed through the interior of the smaller diameter portion of said tip body and the interior of said ultrasonic probe to observe the tissue in the body cavity in front of said nut member.

**5.** The ultrasonic endoscope according to claim **3**, further comprising:

an anti-rotation member, located adjacent to the intermediate step surface, for preventing relative rotation between an outer cylindrical surface of the smaller diameter portion and an inner cylindrical surface of said ultrasonic probe.

**6.** The ultrasonic endoscope according to claim **3**, wherein said ultrasonic probe includes:

a receptacle having a first annular end portion contacting the intermediate step surface, a second annular end portion defining a recess for accommodating said nut member therein, and a strut connecting the first annular end portion to the second annular end portion;

a generally annular array of ultrasonic vibrators held by and between the first and second annular end portions in a longitudinal direction of said receptacle and by the strut in a circumferential direction of said receptacle; and

a flexible board extending from said generally annular array and passing between an interior of the first

annular end portion of said receptacle and the smaller diameter portion of said tip body.

7. The ultrasonic endoscope according to claim 3, further comprising:

an arcuate hole formed in said tip body within a predetermined angular range with respect to the longitudinal axis of said tip body, wherein a flexible board extending from the ultrasonic endoscope is passed through the arcuate hole; and

an opening for inflating and deflating a balloon, the opening being formed in said tip body outside the predetermined angular range.

8. The ultrasonic endoscope according to claim 7, further comprising:

a water drain and injection channel formed in said tip body outside the predetermined angular range; and an air exhaust channel formed in said tip body outside the predetermined angular range;

wherein both of the channels communicate with the opening.

9. The ultrasonic endoscope according to claim 8, wherein the arcuate hole is divided into two arcuate hole sections by a reinforcement link of said tip body.

10. The ultrasonic endoscope according to claim 3, further comprising:

first and second grooves for cooperatively fixing an inflatable balloon onto the ultrasonic endoscope, said first and second grooves being respectively formed in said tip body and said ultrasonic probe.

11. An ultrasonic endoscope comprising:

a tip body;

an ultrasonic probe, fitted on said tip body, for performing radial scanning generally perpendicular to a longitudinal axis of said tip body;

a treatment tool insertion channel passed through an interior of said tip body and an interior of said ultrasonic probe to enable access of a treatment tool to a tissue in a body cavity in front of a distal end of said tip body beyond said ultrasonic probe;

an illumination system passed through the interior of said tip body and the interior of said ultrasonic probe to illuminate the tissue in the body cavity in front of the distal end of said tip body beyond said ultrasonic probe; and

an observing system passed through the interior of said tip body and the interior of said ultrasonic probe to observe the tissue in the body cavity in front of the distal end of said tip body beyond said ultrasonic probe.

12. The ultrasonic endoscope according to claim 11, wherein:

said tip body and said ultrasonic probe have a respective cylindrical outer surface and a cylindrical inner surface fitted together; and

an anti-rotation member is provided to prevent relative rotation between the cylindrical outer and inner surfaces when fitted together.

13. The ultrasonic endoscope according to claim 11, wherein said ultrasonic probe includes:

a receptacle having a first annular end portion, a second annular end portion, and a strut connecting the first annular end portion to the second annular end portion;

a generally annular array of ultrasonic vibrators held by and between the first and second annular end portions in a longitudinal direction of said receptacle and by the strut in a circumferential direction of said receptacle; and

a flexible board extending from said generally annular array and passed through an interior of the first annular end portion.

14. The ultrasonic endoscope according to claim 11, further comprising:

an arcuate hole formed in said tip body within a predetermined angular range with respect to the longitudinal axis of said tip body, wherein a flexible board extending from the ultrasonic endoscope is passed through the arcuate hole; and

an opening for inflating and deflating a balloon, the opening being formed in said tip body outside the predetermined angular range.

15. The ultrasonic endoscope according to claim 14, further comprising:

a water drain and injection channel formed in said tip body outside the predetermined angular range; and an air exhaust channel formed in said tip body outside the predetermined angular range;

wherein both of the channels communicate with the opening.

16. The ultrasonic endoscope according to claim 15, wherein the arcuate hole is divided into two arcuate hole sections by a reinforcement link of said tip body.

17. The ultrasonic endoscope according to claim 11, further comprising:

first and second grooves for cooperatively fixing an inflatable balloon onto the ultrasonic endoscope, said first and second grooves being respectively formed in said tip body and said ultrasonic probe.

18. An ultrasonic endoscope comprising:

a tip body having a cylindrical outer surface, and a first groove formed in a part of the cylindrical outer surface;

an ultrasonic probe having a cylindrical inner surface, and a second groove formed in a part of the cylindrical inner surface, the cylindrical inner surface of said ultrasonic probe being fitted on the cylindrical outer surface of said tip body;

an anti-rotation member engaged with the first and second grooves when the cylindrical inner surface of said ultrasonic probe is fitted on the cylindrical outer surface of said tip body, to thereby prevent relative rotation between said ultrasonic probe and said tip body.

19. An ultrasonic endoscope according to claim 18, wherein said ultrasonic probe includes:

a receptacle having a first annular end portion defining the part of the cylindrical inner surface, a second annular end portion, and a strut connecting the first annular end portion to the second annular end portion;

a generally annular array of ultrasonic vibrators held by and between the first and second annular end portions in a longitudinal direction of said receptacle and by the strut in a circumferential direction of said receptacle; and

a flexible board extending from the generally annular array and passed between an interior of the first annular end portion of said receptacle and the cylindrical outer surface of said tip body.

20. The ultrasonic endoscope according to claim 18, further comprising:

an arcuate hole formed in said tip body within a predetermined angular range with respect to the longitudinal axis of said tip body, wherein a flexible board extending from the ultrasonic endoscope is passed through the arcuate hole; and

9

an opening for inflating and deflating a balloon, the opening being formed in said tip body outside the predetermined angular range.

21. The ultrasonic endoscope according to claim 20, further comprising:

a water drain and injection channel formed in said tip body outside the predetermined angular range; and an air exhaust channel formed in said tip body outside the predetermined angular range;

wherein both of the channels communicate with the opening.

22. The ultrasonic endoscope according to claim 21, wherein the arcuate hole is divided into two arcuate hole sections by a reinforcement link of said tip body.

23. The ultrasonic endoscope according to claim 18, further comprising:

first and second grooves for cooperatively fixing an inflatable balloon onto the ultrasonic endoscope, said

10

first and second grooves being respectively formed in said tip body and said ultrasonic probe.

24. An united assembly of an ultrasonic probe to be used in an ultrasonic endoscope, comprising:

a receptacle having a first annular end portion, a second annular end portion, and a strut connecting the first annular end portion to the second annular end portion; a generally annular array of ultrasonic vibrators held by and between the first and second annular end portions in a longitudinal direction of said receptacle and by the strut in a circumferential direction of said receptacle; and

a flexible board extending from the generally annular array and passed through an interior of the first annular end portion.

\* \* \* \* \*

专利名称(译)	前视和径向扫描超声内窥镜		
公开(公告)号	<a href="#">US6514210</a>	公开(公告)日	2003-02-04
申请号	US09/850225	申请日	2001-05-08
[标]申请(专利权)人(译)	旭光学工业株式会社		
申请(专利权)人(译)	ASAHI KOGAKU工业株式会社		
当前申请(专利权)人(译)	宾得株式会社		
[标]发明人	OHARA KENICHI HASHIYAMA TOSHIYUKI		
发明人	OHARA, KENICHI HASHIYAMA, TOSHIYUKI		
IPC分类号	A61B8/12 A61B1/005 A61B1/00 A61B8/14		
CPC分类号	A61B8/4488 A61B8/12 A61B1/0051 A61B8/445		
助理审查员(译)	JAIN , RUBY		
优先权	2000136733 2000-05-10 JP		
其他公开文献	US20010041839A1		
外部链接	<a href="#">Espacenet</a> <a href="#">USPTO</a>		

摘要(译)

在径向扫描中，在超声波探头和尖端体中形成前视超声波内窥镜，使得能够使超声波探头的外表面与尖端主体的外表面在边界处相互齐平的定心配合部分。并且，超声波探头的内周表面与尖端主体的前半部分的配合表面之间的间隙形成为大于定心配合部分之间的间隙。

