



US 20050124899A1

(19) **United States**

(12) **Patent Application Publication**
Byrd et al.

(10) **Pub. No.: US 2005/0124899 A1**
(43) **Pub. Date: Jun. 9, 2005**

(54) **SAFETY SYSTEMS AND METHODS FOR ENSURING SAFE USE OF INTRA-CARDIAC ULTRASOUND CATHETERS**

(60) Provisional application No. 60/349,060, filed on Jan. 16, 2002.

Publication Classification

(75) Inventors: **Charles Bryan Byrd**, Medford, NJ (US); **Praveen Dala-Krishna**, Bensalem, PA (US); **David A. Jenkins**, Flanders, NJ (US)

(51) **Int. Cl.⁷** **A61B 8/14**
(52) **U.S. Cl.** **600/467**

Correspondence Address:
Heller Ehrman White & McAuliffe
Suite 300
1666 K Street, N.W.
Washington, DC 20006 (US)

(57) **ABSTRACT**

A system and method for limiting a temperature induced in a body by an ultrasound imaging catheter are provided. The method includes receiving, at an isolation box, an imaging signal from an imaging catheter, receiving, at an isolation box, a signal indicative of a temperature of tissue adjacent to the imaging catheter, removing power to the imaging catheter at the isolation box if the signal indicates the temperature of tissue adjacent to the imaging catheter exceeds a known value, and sending the imaging signal from the catheter to a processor if the signal indicates the temperature of tissue adjacent to the imaging catheter is less than the limit.

(73) Assignee: **EP MedSystems, Inc.**, West Berlin, NJ

(21) Appl. No.: **10/998,039**

(22) Filed: **Nov. 29, 2004**

Related U.S. Application Data

(63) Continuation-in-part of application No. 10/345,806, filed on Jan. 16, 2003.

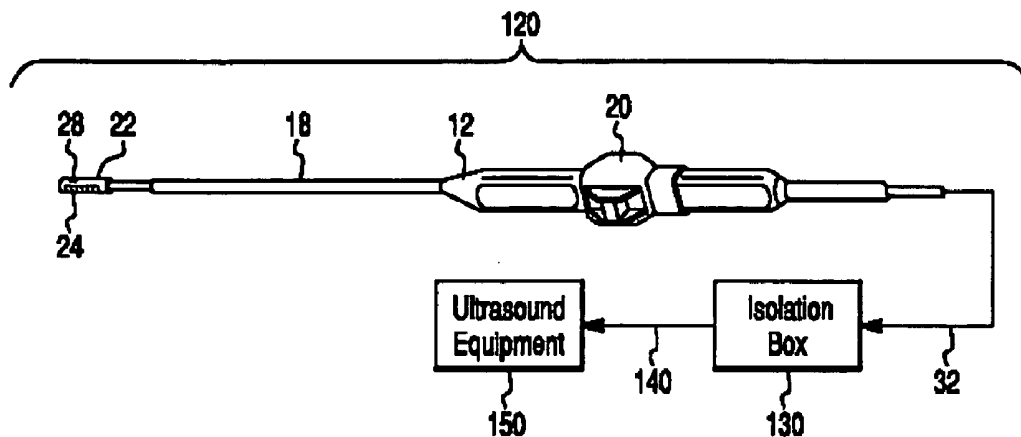

Fig. 1

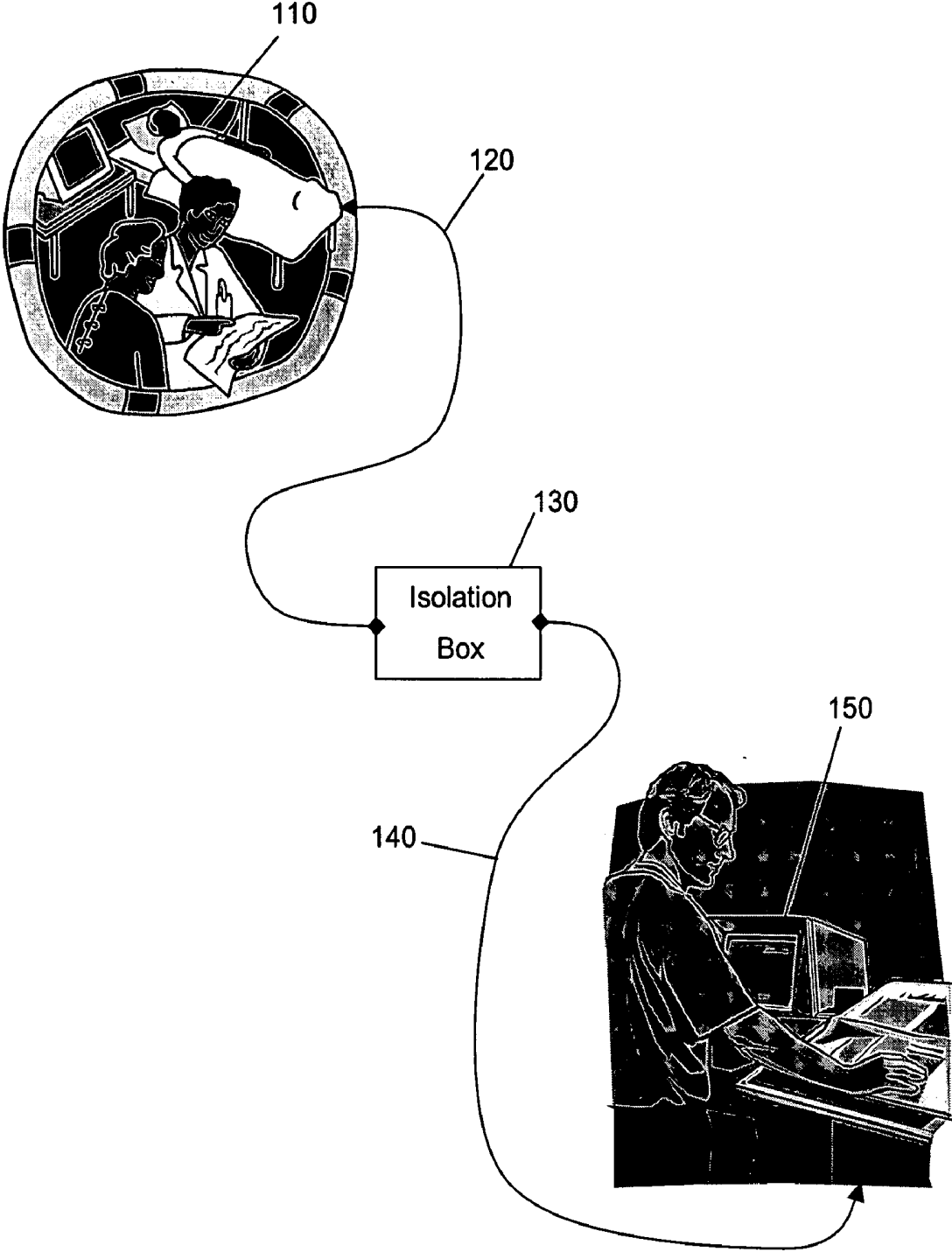

Fig. 2

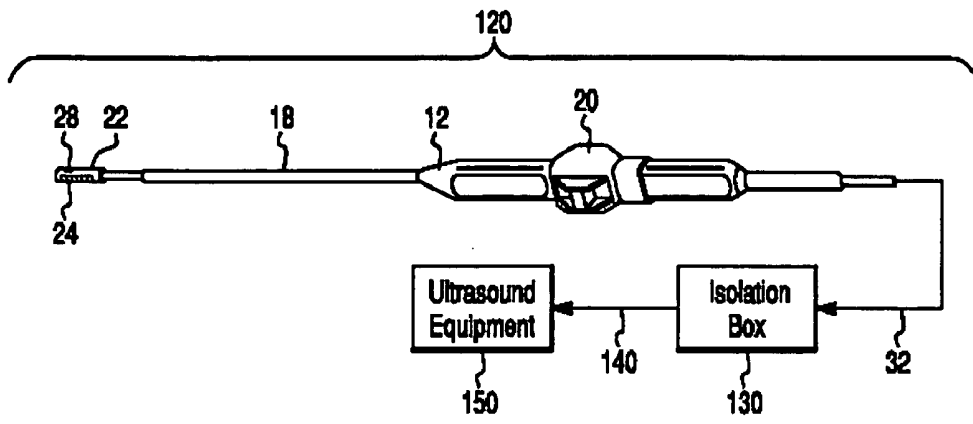

Fig. 3

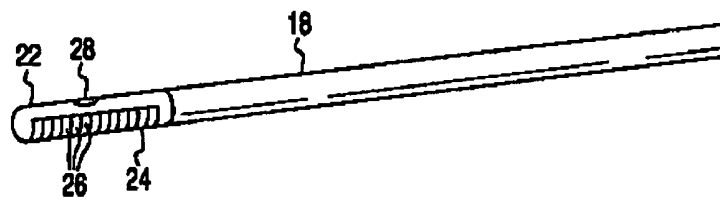

Fig. 4

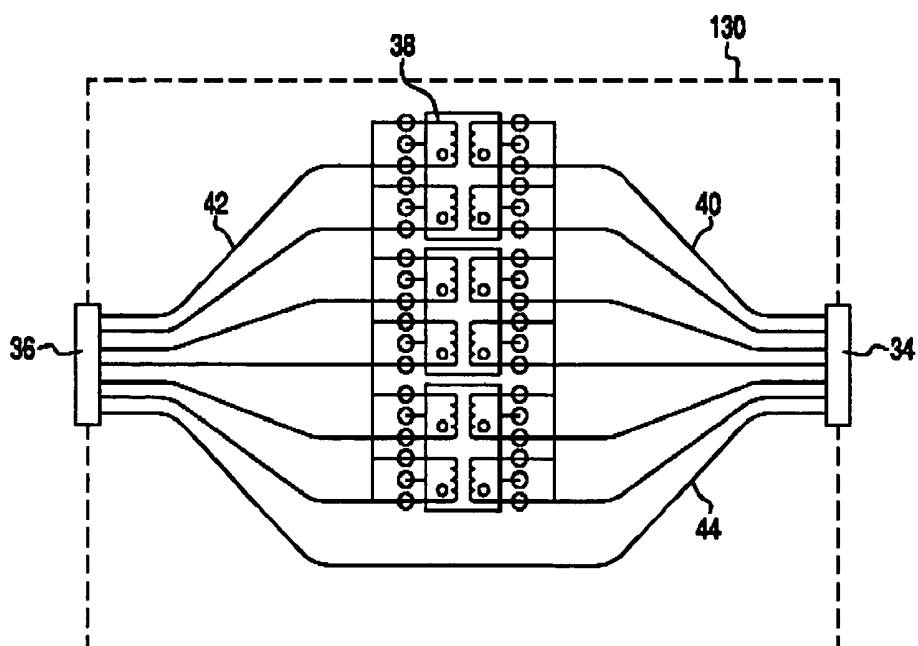

Fig. 5

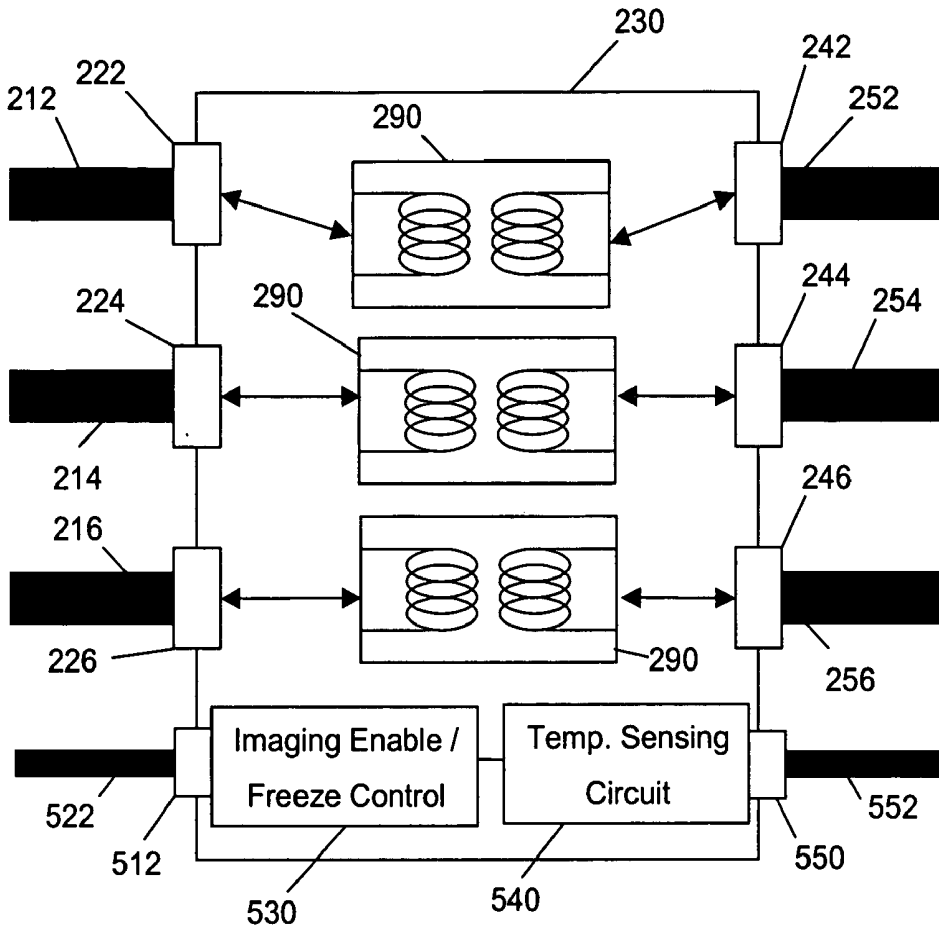
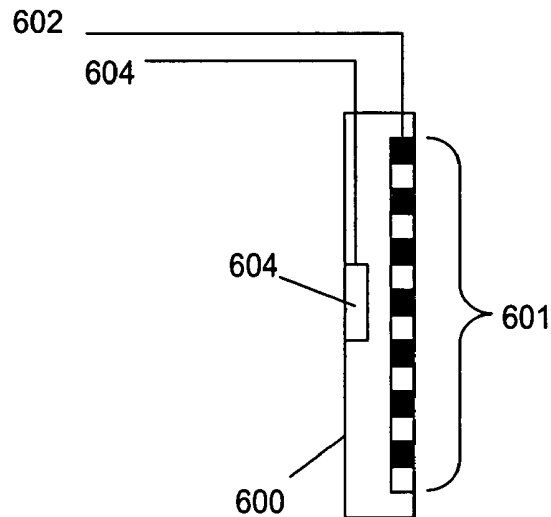
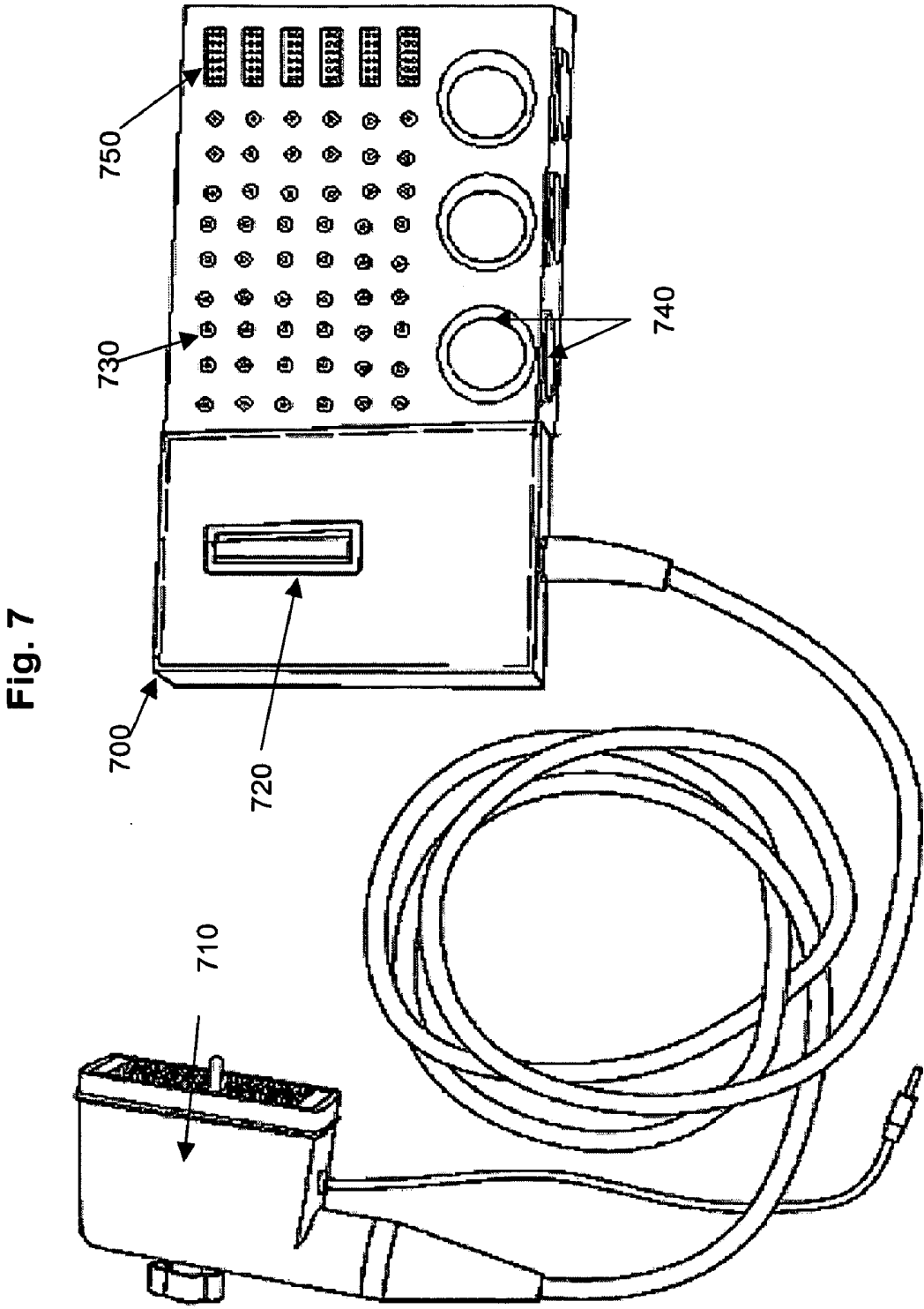

Fig. 6





**SAFETY SYSTEMS AND METHODS FOR
ENSURING SAFE USE OF INTRA-CARDIAC
ULTRASOUND CATHETERS**

CORRESPONDING RELATED APPLICATIONS

[0001] The present invention is a continuation in part (CIP) of parent application Ser. No. 10/345,806 entitled "ULTRASOUND IMAGING CATHETER ISOLATION SYSTEM WITH TEMPERATURE SENSOR" filed on Jan. 16, 2003, claiming the benefit of U.S. Provisional Patent Application Ser. No. 60/349,060, filed on Jan. 16, 2002. The present application claims the benefit of and priority to these applications, the entire contents of which being incorporated by reference herein in their entirety.

[0002] This application is also related to co-pending application _____, entitled "METHOD AND APPARATUS FOR ISOLATING A CATHETER INTERFACE", filed concurrently herewith. The entire contents of this co-pending application are incorporated by reference herein in its entirety.

BACKGROUND OF THE INVENTION

[0003] 1. Field of the Invention

[0004] The present invention is directed toward improvements in ultrasound catheters and more particularly toward an ultrasound catheter that includes a temperature monitoring system carried at least in part by the catheter for preventing the overheating of the same.

[0005] 2. Description of the Related Art

[0006] Medical imaging technology is used to improve the diagnosis and treatment of medical conditions. Presently available medical imaging technology includes a wide variety of ultrasound, X-ray, nuclear, magnetic resonance imaging (MRI) and other imaging systems.

[0007] For some medical imaging technologies, such as those involving intra-body probes (e.g., ultrasound imaging catheters, electrophysiology (EP) catheters, ablation catheters, etc.), particular attention is paid to thermal safety concerns arising from use of electrical devices within a patient's body. By way of example, intra-body ultrasound catheters typically include an ultrasound transducer which converts electrical voltage to sound waves. Used with higher power, such as that used with color Doppler imaging, and for a lengthy period of time, it is possible that the transducer, and hence, catheter tip, may heat up, and such heat may well be above a safe body temperature. While computer software can be used to regulate the amount of power put into the catheter, a software malfunction could result in too much power being delivered. It is, therefore, desirable to have a safety cut-off mechanism or other control to avoid such a problem.

[0008] Actual temperature monitoring near the top or tip of the catheter is most desirable, with feedback to the computer, with an automatic warning or shut down based upon some upper pre-determined temperature limit. The safety standard set in the U.S. FDA guidelines is 43° C. although this may vary depending on the environment in which the catheter is being used.

[0009] Other problems with the prior art not described above can also be overcome using the teachings of the

present invention, as would be readily apparent to one of ordinary skill in the art after reading this disclosure.

SUMMARY OF THE INVENTION

[0010] An embodiment of the present invention includes an intra-cardiac ultrasound catheter having an elongated catheter body, comprising an ultrasound transducer carried by the elongated catheter body for use in imaging, a temperature sensor positioned relative to the ultrasound transducer along the elongated catheter body so as to sense a temperature caused by the ultrasound transducer, and a plurality of wires for coupling the ultrasound transducer and the temperature sensor to a cutoff circuit configured to automatically cutoff power to the ultrasound transducer if the temperature sensed by the temperature sensor exceeds a known value.

[0011] Another embodiment of the present invention includes a method of limiting a temperature induced in a body by an ultrasound imaging catheter are provided. The method preferably comprises receiving, at an isolation box, an imaging signal from an imaging catheter, receiving, at an isolation box, a signal indicative of a temperature of tissue adjacent to the imaging catheter, removing power to the imaging catheter at the isolation box if the signal indicates the temperature of tissue adjacent to the imaging catheter exceeds a known value, and sending the imaging signal from the catheter to a processor if the signal indicates the temperature of tissue adjacent to the imaging catheter is less than the limit.

[0012] Another embodiment of the present invention includes a safety system for ensuring safe use of an intra-cardiac catheter, comprising means for receiving an imaging signal from the intra-cardiac catheter, means for receiving a signal indicative of a temperature of tissue adjacent to the intra-cardiac catheter, and means for removing power to the intra-cardiac catheter at an isolation box if the signal indicates the temperature of tissue adjacent to the intra-cardiac catheter exceeds a known value.

BRIEF DESCRIPTION OF THE DRAWINGS

[0013] FIG. 1 is a representation of a facility in which a patient undergoes intra-body imaging according to an embodiment of the present invention;

[0014] FIG. 2 is a representation of a catheter employing an embodiment of the present invention with an isolation system shown schematically;

[0015] FIG. 3 is a detailed view of an end of the catheter shown in FIG. 2 illustrating an ultrasound transducer and a thermistor;

[0016] FIG. 4 is a schematic representation of an isolation circuit according to an embodiment of the present invention;

[0017] FIG. 5 is a schematic representation of an isolation box according to an embodiment of the present invention;

[0018] FIG. 6 is a schematic view of linear phased array transducer with a thermistor according to an embodiment of the present invention; and

[0019] FIG. 7 is a perspective view of an isolation box according to an embodiment of the present invention.

DETAILED DESCRIPTION OF THE
EXEMPLARY EMBODIMENTS

[0020] Reference will now be made in detail to exemplary embodiments of the present invention. Wherever possible, the same reference numbers will be used throughout the drawings to refer to the same or like parts.

[0021] The present invention provides improved electrical isolation for catheters and similar probes that may be inserted in a body, such as the body of a mammal, including a human. Electrical isolation is important because leakage of electrical current may lead to deleterious effects, including cardiac arrhythmia or cardiovascular collapse. Two types of isolation are important. One type, sometimes referred to as "patient sink leakage current," may arise when an external source of voltage, such as 250 volts from an electrical outlet or electrical equipment, passes through the catheter and the patient's body or between one catheter element and another catheter or catheter element within the body. This type of isolation is associated with equipment fault conditions and is addressed in the design of intrabody probe systems (e.g., electrophysiology electrode catheters and ultrasound imaging catheters) to protect the patient from deleterious shocks caused by an electrical fault. A second type of isolation limits leakage currents that may arise under no fault conditions. Long probes containing conductors, such as electrophysiology and ultrasound imaging catheters, may exhibit electric currents induced in the conductors by electromagnetic radiation present in the room. Patient safety requires limiting both types of leakage currents to low (e.g., 20 microamps or less) levels. Generally, fault-type leakage currents may be isolated on a per catheter (or probe) basis, since a single failure presents a significant threat and there is a low likelihood that multiple faults will occur simultaneously. In contrast, no fault leakage isolation must address multiple catheters (or probes), since leakage currents from induced currents in multiple catheters may be additive. Consequently, isolating each catheter provides improved patient safety. Providing such isolation close to the patient so as to reduce the length of electrical conductors on the patient side of the isolation also improves patient safety. Such measures are of particular importance for intracardiac probes.

[0022] According to an embodiment of the present invention as shown in FIG. 1, an isolation box 130 is provided that electrically couples an imaging probe 120 to an ultrasound equipment 150 via a cable 140. The isolation box 130 is positioned as close to the patient 110 as possible consistent with room layout and sterility limitations (e.g., attached to the patient's bed or operating/imaging table) so as to minimize the length of imaging probe 120.

[0023] The imaging probe 120 preferably includes a catheter and transducer assembly 12 as shown in FIG. 2. In many respects, the catheter and transducer assembly 12 may be constructed in a conventional manner similar, for example, to the ultrasound imaging catheter described in application Ser. No. 09/263,755 filed Mar. 5, 1999, the entire content of said application being incorporated herein by reference. It should be noted that the present invention is not limited to the specific catheter assembly disclosed in the prior referenced application as the invention is applicable to various catheters designed for intravascular/intracardiac echocardiography and for other physiological uses. In par-

ticular, the present invention is applicable to any intravascular/intracardiac catheter including an electrical conductor (e.g., a signal or guide wire) that carries electrical currents or in which electrical currents may be induced by electromagnetic radiation.

[0024] The catheter assembly 12 includes an elongated catheter generally in the form of a tube 18. The proximal end of the tube 18 is connected to a handle mechanism 20 which could include means for controlling the steering of an ultrasound probe 22 mounted at the distal end of the catheter tube 18. The ultrasound probe 22 includes an ultrasound transducer assembly 24, which is comprised of a number of ultrasonic transducer elements 26 having wires connected thereto which are provided inside the tube. Although only twelve or so transducer elements 26 are shown in FIG. 3, substantially any number of transducer elements may be employed as described in the prior application discussed above. These transducer elements can also be deployed in many geometrical orientations, such as linear, circular, curved, etc. Typically, the transducer includes sixty-four elements.

[0025] Mounted near the distal end, such as on the reverse side of the ultrasound transducer probe 22 is a thermistor 28. The thermistor 28 is preferably embedded within the probe 22 so as to provide a smooth outer surface on the probe 22. The exact location of the thermistor 28 is not critical. However, it must be in such a position so as to be able to sense the temperature of the tissue in the vicinity of the probe 22 and/or the temperature of the probe 22 itself without interfering with the operation of the same. Furthermore, while the invention has been described with specific reference to a thermistor 28, it should be readily apparent that other types of safety-related sensors may also be employed which are capable of sensing temperature or other safety-related parameters. The electrical wires leading from the thermistor 28 pass through the inside of the catheter body 18 to the exterior of the body in substantially the same manner as the numerous wires connected to the ultrasonic transducer elements 26.

[0026] The ultrasonic equipment 150 illustrated in FIG. 1 is a conventional ultrasound machine which may operate in a manner well known in the art. This equipment 150 may be located a distance from a patient's bed outside of the sterile area. The isolation box 130, however, is intended to be placed on or near a patient's bed within the sterile area, with cable 140 connecting the two together. Alternatively, the isolation box 130 may be placed at the boundary of the sterile area as described more fully below.

[0027] The cable 32 from the catheter assembly 12 carries a plug at the end thereof that plugs into the isolation box 130 to form the various electrical connections. Since the isolation box 130 is relatively small and is located on or near the patient's bed, the cable 32 can also be relatively short, thereby reducing the cost of the same. The cable 32 carries all of the leads from the ultrasonic transducers 26, the leads from the thermistor 28 and any other leads that may be used in connection with the catheter assembly 12. For example, the catheter assembly 12 may carry other electrodes and/or transducers at or near the tip thereof or elsewhere along the catheter body 18 for various other purposes.

[0028] The isolation box 130 preferably has an input connector or socket 34 for connection to the cable 32 and an

output socket or connector **36** for connection to the cable **140** that leads to the ultrasound equipment **150**. These may be the card connector disclosed herein or conventional sockets or connectors well known in the art.

[0029] According to an embodiment of the present invention, the isolation box **130** includes a plurality of isolation transformers **38** as shown in **FIG. 4**. In order to keep the isolation box **130** as small as possible, relatively small transformers **38** are utilized as a significant number of them are typically implemented within the isolation box **130**. There may be one isolation transformer **38** for each of the ultrasonic transducer elements **26** and, potentially, an opto isolator for the thermistor **28**. Thus, if there are sixty-four transducer elements **26**, an equal number (i.e., sixty-four transformers) of transformers **38** are required. One transformer which may be used with various embodiments of the present invention is a wide band isolation transformer sold by Rhombus Industries Inc. of Huntington, Calif. as Rhombus Model No. T-1113.

[0030] One side of each transformer **38** may be connected by leads **40** to the socket or connector **34** so as to be connected to the transducer assembly **12** by way of the cable **32**. Similar leads **42** connect the opposite side of each transformer **38** to the socket or connector **36** for ultimate connection to the ultrasound equipment **150** through the cable **140**. Other leads such as shown at **44** may pass directly through the isolation box **130** from connector **34** to connector **36** without being connected to an isolation transformer **38** if the same is desired. For example, the lead from the thermistor **28** may or may not pass through an isolation transformer **38** but may be connected directly to the ultrasound equipment **150** by passing through the isolation box **130**. Alternative isolation circuitry may also be employed. As should be readily apparent to those skilled in the art, appropriate circuitry may be located either in the isolation box **130** or the ultrasound equipment **150** or elsewhere for interpreting the signal from the thermistor **28** for controlling the ultrasound equipment **150** in response thereto.

[0031] An isolation box **230** according to an embodiment of the present invention is shown in the block diagram of **FIG. 5**. According to this embodiment, the isolation box **230** includes a plurality of probe ports **222, 224, 226** for coupling to a plurality of probe elements **212, 214, 216** respectively. While only three probe ports **222, 224, 226** and three probe elements **212, 214, 216** are shown, the number of ports and probes, and the types of ports and probes may vary for any given implementation. By way of example, the isolation box **230** may include sixty-four or more edge contact connector type ports for sixty-four individual probe elements. Further, the same isolation box **230** might also include one or more other connectors that pertain to other elements, such as an EP recording system, a mapping system, etc., as shown in the exemplary implementation of **FIG. 7**.

[0032] The probe ports **222, 224, 226** are coupled to one or more processor ports **242, 244, 246** (after passing through isolation circuit **290**) for coupling to a corresponding number of processor cables **252, 254, 256**. According to one embodiment of the present invention, the processor ports are integrated into a one or more high-density ZIF connector(s) **710** as shown in **FIG. 7**. The integrated port **710** may be coupled to one or more processors via one or more high-density cables. Other configurations are also contemplated.

[0033] Additionally, one or more of ports **242, 244, 246** and/or **710** may be configured to have a card connector pass through a plastic barrier to establish an electrical connection therewith. In this manner, the plastic barrier serves as a boundary between the sterile and non-sterile environments, and may be disposable to allow re-use of one or more of the various components. The plastic barrier may comprise, for example, a plastic sleeve/bag, etc.

[0034] According to an embodiment of the present invention, filter(s) may be included in the isolation box to suppress noise on an imaging signal from a probe of a first type caused by a probe of a second type. As an example, a bandpass filter may be employed in-line with an ultrasound imaging probe element to suppress noise generated by a radio-frequency (RF) probe. By providing signal filtering such as band limiting filters, the isolation box provides greater capacity for multiple probes of differing types to operate at the same time. Similarly, stages of amplification and impedance matching circuits could also be deployed to enhance signal-to-noise ratios of various signals passed through such an isolation mechanism.

[0035] Additionally, according to an embodiment of the present invention, the thermistor **28** automatically shuts off the catheter assembly **12** at the isolation box **130**. By way of example, an output of thermistor **28** may be coupled to an enable/disable input to a plurality of gates gating wires passing to/from the transducer elements **26**. So long as the temperature of catheter assembly **12** remains at a safe level, such as not more than about 43° C., the gates remain enabled allowing signals to pass to/from transducer elements **26**. However, should the temperature of catheter assembly **12** reach or exceed an unsafe level, thermistor **28** disables the gates, automatically shutting off the catheter assembly **12**. Other configurations for automatic shutoff are also contemplated.

[0036] One such scenario would be to provide a thermistor **604** behind a linear ultrasound transducer array **601** (forming part of probe **120**), as shown in **FIG. 6**, coupled via wires **602, 604** to the isolation box **230** shown in **FIG. 5**. Preferably, the wire **604** is coupled to port **550** on isolation box **230**. Additionally, the isolation box **230** includes port **512** coupled to ultrasound equipment **150** via wire **522**. The isolation box **230** is configured to disable transmission of ultrasound signals from the ultrasound equipment **150** by disabling the transmit circuitry by signaling the ultrasound equipment **150** through a trigger mechanism such as a hardware interrupt. In particular, the isolation box **230** may include a temperature sensing circuit **540** for sensing a temperature of transducer array **601** via thermistor **604**, and an imaging enable/freeze control circuit **530** for disabling the transmit circuitry based on the temperature sensed by temperature sensing circuit **540**. Other mechanisms could include disabling an array of multiplexers or transmit channel amplifiers commonly used in such circuits.

[0037] An example of an ultrasound catheter connector and isolation system employing an embodiment of the present invention is shown in **FIG. 7**. In particular, the system includes a patient side isolation module **700** (preferably with thermal cutoff circuitry), with a plurality of interconnection ports for coupling with various electrical components. In particular, the system preferably includes a ZIF connector **710**, a plurality of catheter ports **730, 750**, a

plurality of position management ports **740**, and a card edge connector **720**. The ZIF connector **710** may be provided for coupling with ultrasound equipment **150**. The plurality of catheter ports **730**, **750** may be provided for coupling with intra-body catheters (e.g., ultrasound imaging catheters, electrophysiology catheters, etc.). The plurality of position management ports **740** may be provided for coupling with positioning catheters. Other configurations are also contemplated.

[0038] The aforementioned system provides the user with a relatively small, and compact device which can be positioned close to the patient, and is relatively easy to sterilize. Thus, the system is easier to use, safer for the patient, and has a lower maintenance cost due to a reduction in the amount of single use cabling. Other advantages and features will be readily apparent to those of skill in the art after reading this disclosure.

[0039] The foregoing description of various embodiments of the invention has been presented for purposes of illustration and description. It is not intended to be exhaustive or to limit the invention to the precise form disclosed, and modifications and variations are possible in light of the above teachings or may be acquired from practice of the invention. By way of example, the present invention is applicable to any catheter-instrument, such as lasers, optical imagers, thermal ablation devices, RF ablation devices, and ultrasound ablation devices in addition to the devices described above. The embodiments were chosen and described in order to explain the principles of the invention and its practical application to enable one skilled in the art to utilize the invention in various embodiments and with various modifications as are suited to the particular use contemplated.

What is claimed is:

1. An intra-cardiac ultrasound catheter having an elongated catheter body, comprising:

an ultrasound transducer carried by the elongated catheter body for use in imaging;

a temperature sensor positioned relative to the ultrasound transducer along the elongated catheter body so as to sense a temperature caused by the ultrasound transducer; and

a plurality of wires for coupling the ultrasound transducer and the temperature sensor to a cutoff circuit configured to automatically cutoff power to the ultrasound transducer if the temperature sensed by the temperature sensor exceeds a known value.

2. The ultrasound catheter as claimed in claim 1, wherein said temperature sensor comprises a thermistor.

3. The ultrasound catheter as claimed in claim 1, wherein said ultrasound transducer comprises a plurality of transducer elements.

4. An ultrasound imaging catheter system comprising the ultrasound catheter as claimed in claim 3, comprising:

ultrasound equipment electrically coupled to the ultrasound catheter; and

the cutoff circuit configured to automatically cutoff power to the ultrasound transducer if the temperature sensed by the temperature sensor exceeds a known value,

wherein the cutoff circuit is positioned electrically between the ultrasound equipment and the ultrasound catheter.

5. The ultrasound imaging catheter system as claimed in claim 4, wherein said cutoff circuit comprises an isolation circuit including a plurality of transformers.

6. The ultrasound imaging catheter system as claimed in claim 5, wherein the number of transformers is equal to the number of transducer elements.

7. The ultrasound imaging catheter system as claimed in claim 1, wherein the known value is about 43° C.

8. A method of limiting a temperature induced in a body by an ultrasound imaging catheter, comprising:

receiving, at an isolation box, an imaging signal from an imaging catheter;

receiving, at an isolation box, a signal indicative of a temperature of tissue adjacent to the imaging catheter;

removing power to the imaging catheter at the isolation box if the signal indicates the temperature of tissue adjacent to the imaging catheter exceeds a known value; and

sending the imaging signal from the catheter to a processor if the signal indicates the temperature of tissue adjacent to the imaging catheter is less than the limit.

9. The method as claimed in claim 8, wherein the signal indicative of a temperature of tissue adjacent to the imaging sensor is generated by a thermistor.

10. The method as claimed in claim 8, wherein the imaging signal is generated by an ultrasound transducer.

11. The method as claimed in claim 10, wherein the ultrasound transducer comprises a plurality of transducer elements.

12. The method as claimed in claim 8, wherein the known value is about 43° C.

13. An ultrasound imaging catheter system programmed to perform the method as claimed in claim 8.

14. A safety system for ensuring safe use of an intra-cardiac catheter, comprising:

means for receiving an imaging signal from the intra-cardiac catheter;

means for receiving a signal indicative of a temperature of tissue adjacent to the intra-cardiac catheter; and

means for removing power to the intra-cardiac catheter at an isolation box if the signal indicates the temperature of tissue adjacent to the intra-cardiac catheter exceeds a known value.

15. The safety system as claimed in claim 14, wherein the intra-cardiac catheter includes means for generating an ultrasound imaging signal.

16. The safety system as claimed in claim 14, further comprising means for isolating electrical currents propagating along the intra-cardiac catheter.

17. The safety system as claimed in claim 14, wherein the known value is about 43° C.

专利名称(译)	确保安全使用心脏内超声导管的安全系统和方法		
公开(公告)号	US20050124899A1	公开(公告)日	2005-06-09
申请号	US10/998039	申请日	2004-11-29
[标]申请(专利权)人(译)	EP MEDSYST		
申请(专利权)人(译)	EP MedSystems公司, INC.		
当前申请(专利权)人(译)	ST.犹达医疗用品, 房颤DIVISION, INC.		
[标]发明人	BYRD CHARLES BRYAN DALA KRISHNA PRAVEEN JENKINS DAVID A		
发明人	BYRD, CHARLES BRYAN DALA-KRISHNA, PRAVEEN JENKINS, DAVID A.		
IPC分类号	A61B8/12 A61B8/14		
CPC分类号	A61B8/546 A61B8/12		
优先权	60/349060 2002-01-16 US		
其他公开文献	US7648462		
外部链接	Espacenet USPTO		

摘要(译)

提供了一种用于限制由超声成像导管在体内诱发的温度的系统和方法。该方法包括在隔离盒处接收来自成像导管的成像信号，在隔离盒处接收指示与成像导管相邻的组织的温度的信号，如果在隔离盒处移除对成像导管的供电，则信号指示与成像导管相邻的组织的温度超过已知值，并且如果信号指示与成像导管相邻的组织的温度小于限制，则将成像信号从导管发送到处理器。

