



US 20050261587A1

(19) **United States**

(12) **Patent Application Publication**  
**Makin et al.**

(10) **Pub. No.: US 2005/0261587 A1**

(43) **Pub. Date: Nov. 24, 2005**

(54) **ULTRASOUND MEDICAL SYSTEM AND METHOD**

(22) Filed: **May 20, 2004**

**Publication Classification**

(76) Inventors: **Inder Raj S. Makin**, Loveland, OH (US); **T. Douglas Mast**, Cincinnati, OH (US); **Michael H. Slayton**, Tempe, AZ (US); **Peter G. Barthe**, Phoenix, AZ (US); **Jeffrey D. Messerly**, Cincinnati, OH (US); **Waseem Faidi**, Clifton Park, NY (US)

(51) **Int. Cl.<sup>7</sup>** ..... **A61B 8/00**; A61B 8/12;

A61B 8/14

(52) **U.S. Cl.** ..... **600/459**; 600/439

(57) **ABSTRACT**

An ultrasound medical system includes an ultrasound end effector. The ultrasound end effector has an exterior surface, includes a medical ultrasound transducer assembly having at least one medical-treatment ultrasound transducer, and includes at least one tine. The at-least-one tine is deployable to extend away from the exterior surface into patient tissue to provide at least some stabilization of the ultrasound end effector with respect to patient tissue and is retrievable to retract back toward the exterior surface.

Correspondence Address:

**PHILIP S. JOHNSON**  
**JOHNSON & JOHNSON**  
**ONE JOHNSON & JOHNSON PLAZA**  
**NEW BRUNSWICK, NJ 08933-7003 (US)**

(21) Appl. No.: **10/850,041**

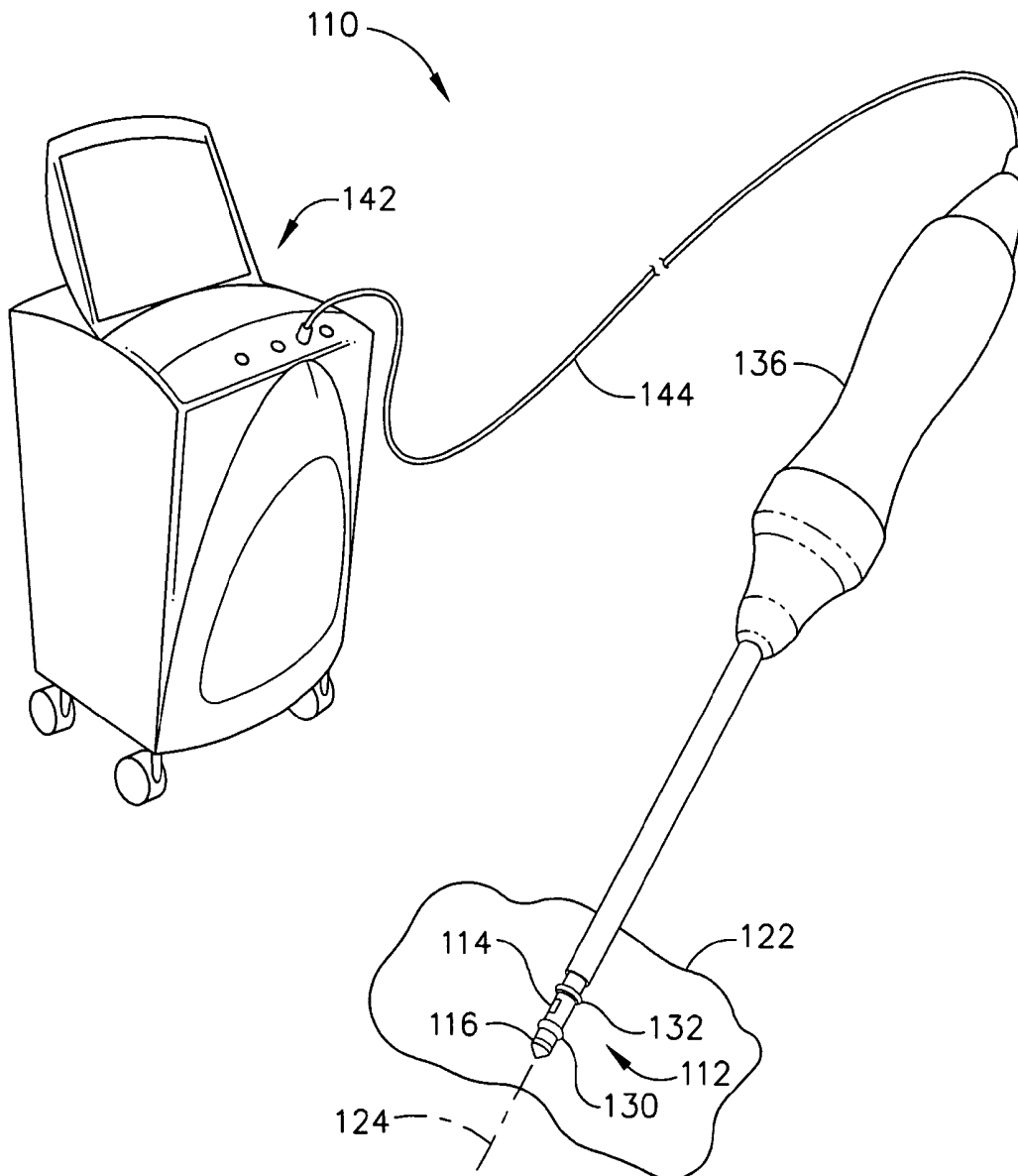

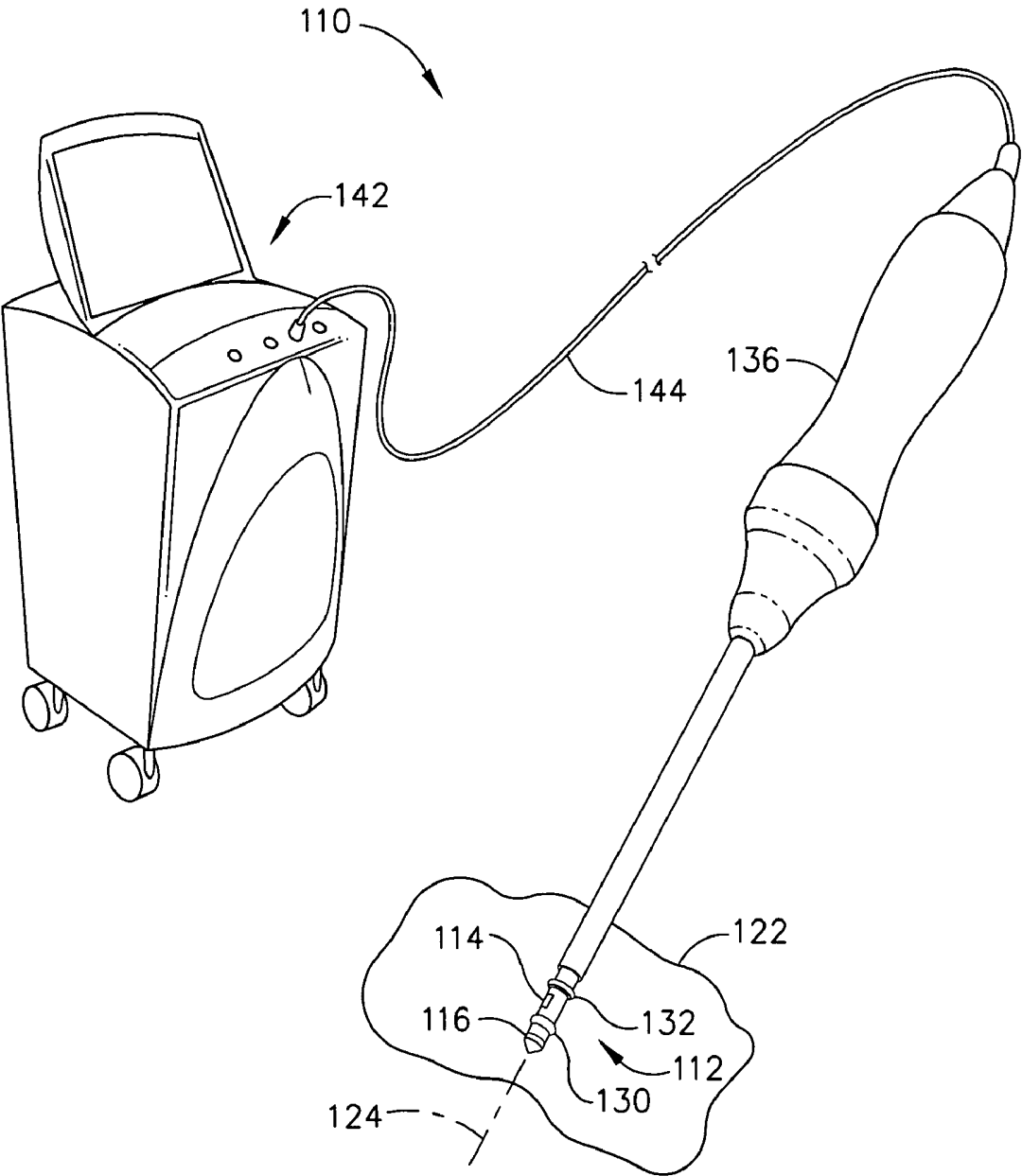

FIG. 1

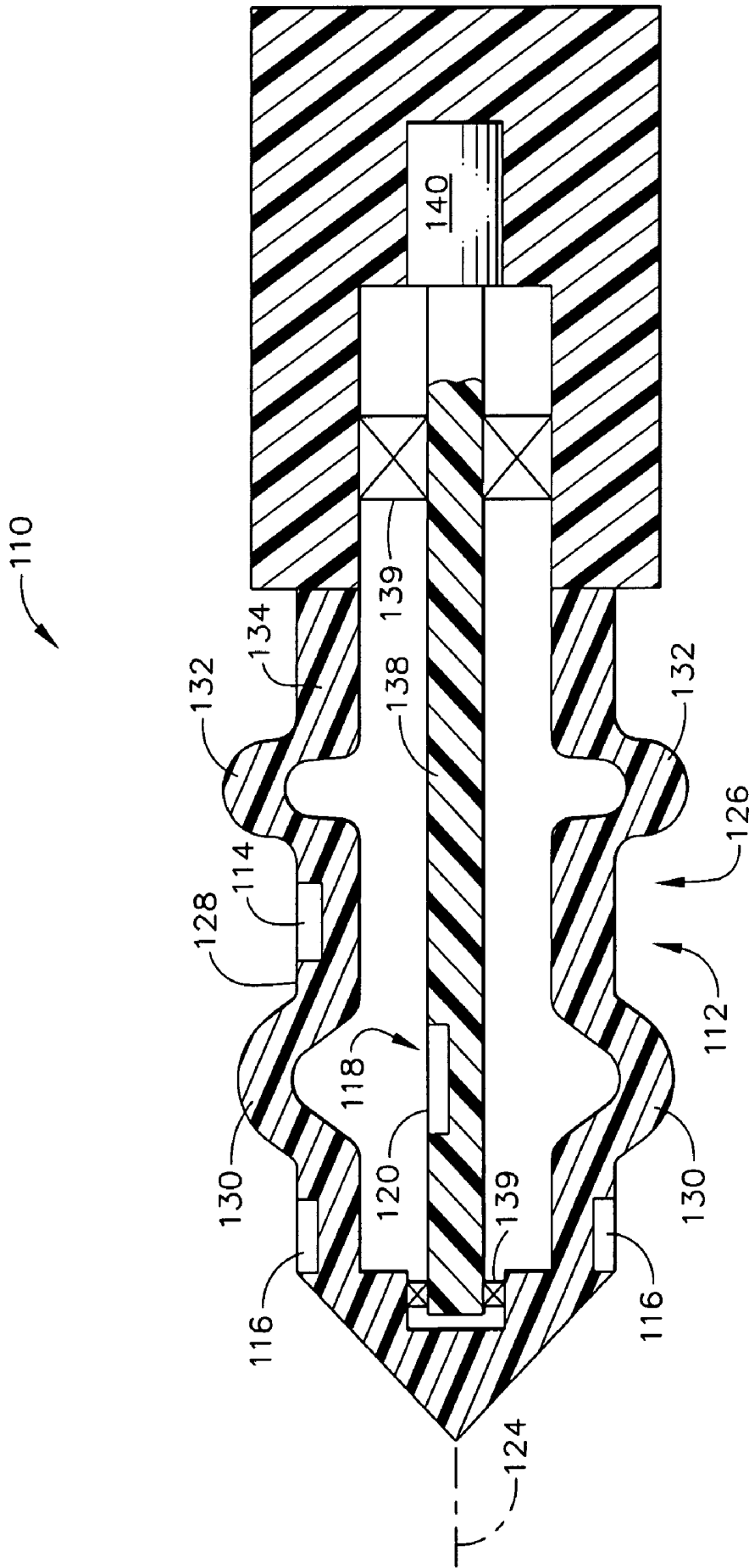

FIG. 2

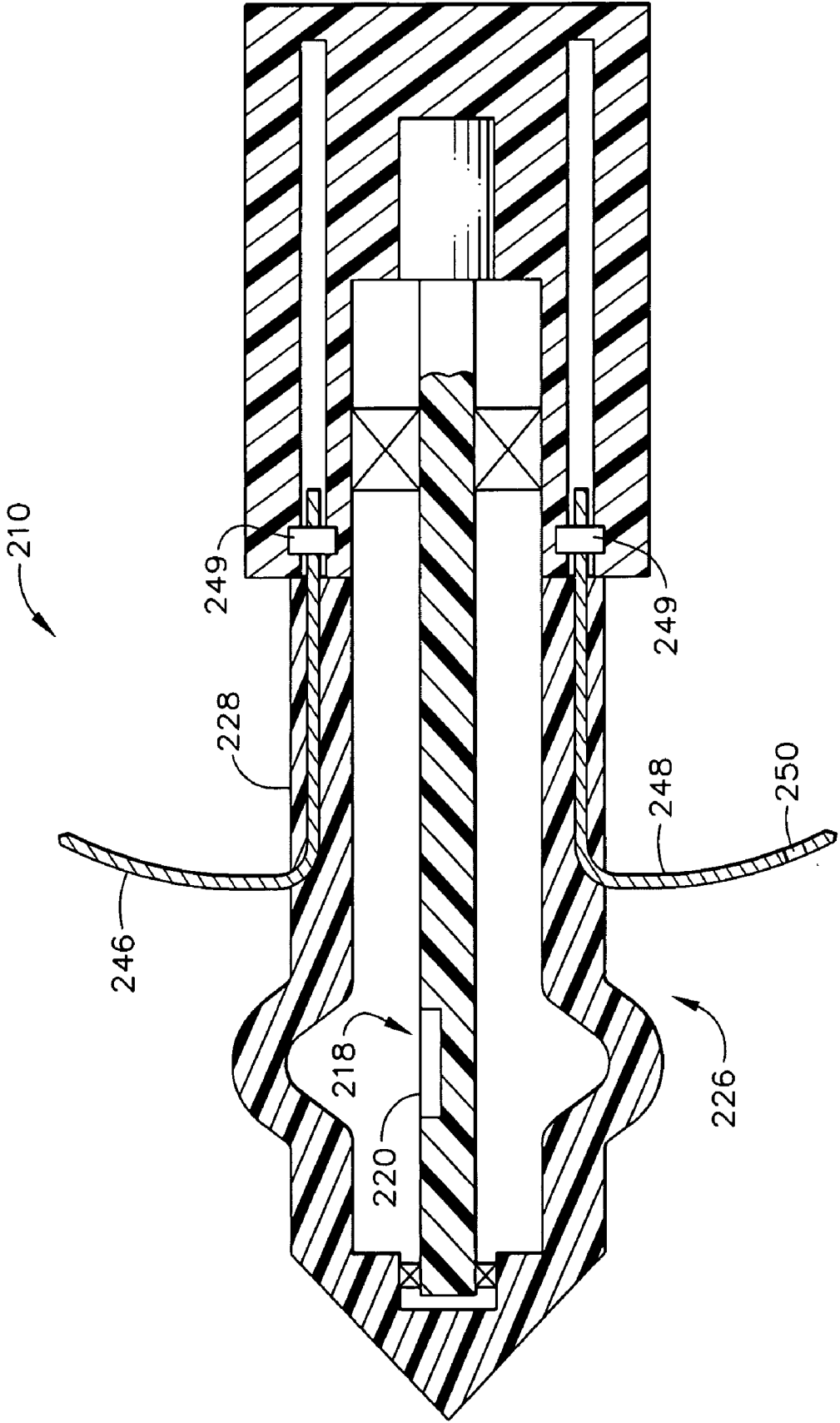

FIG. 3

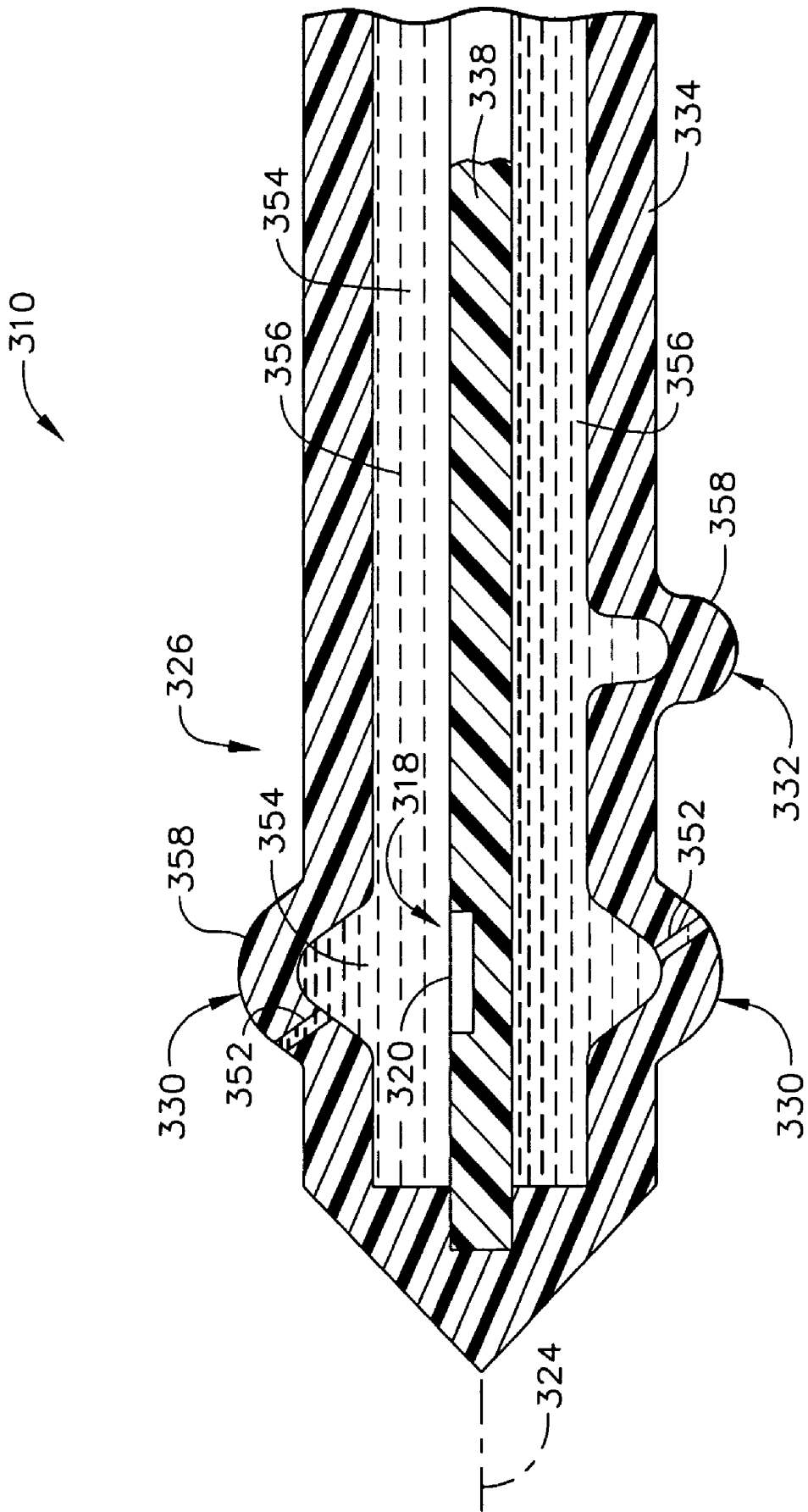

FIG. 4

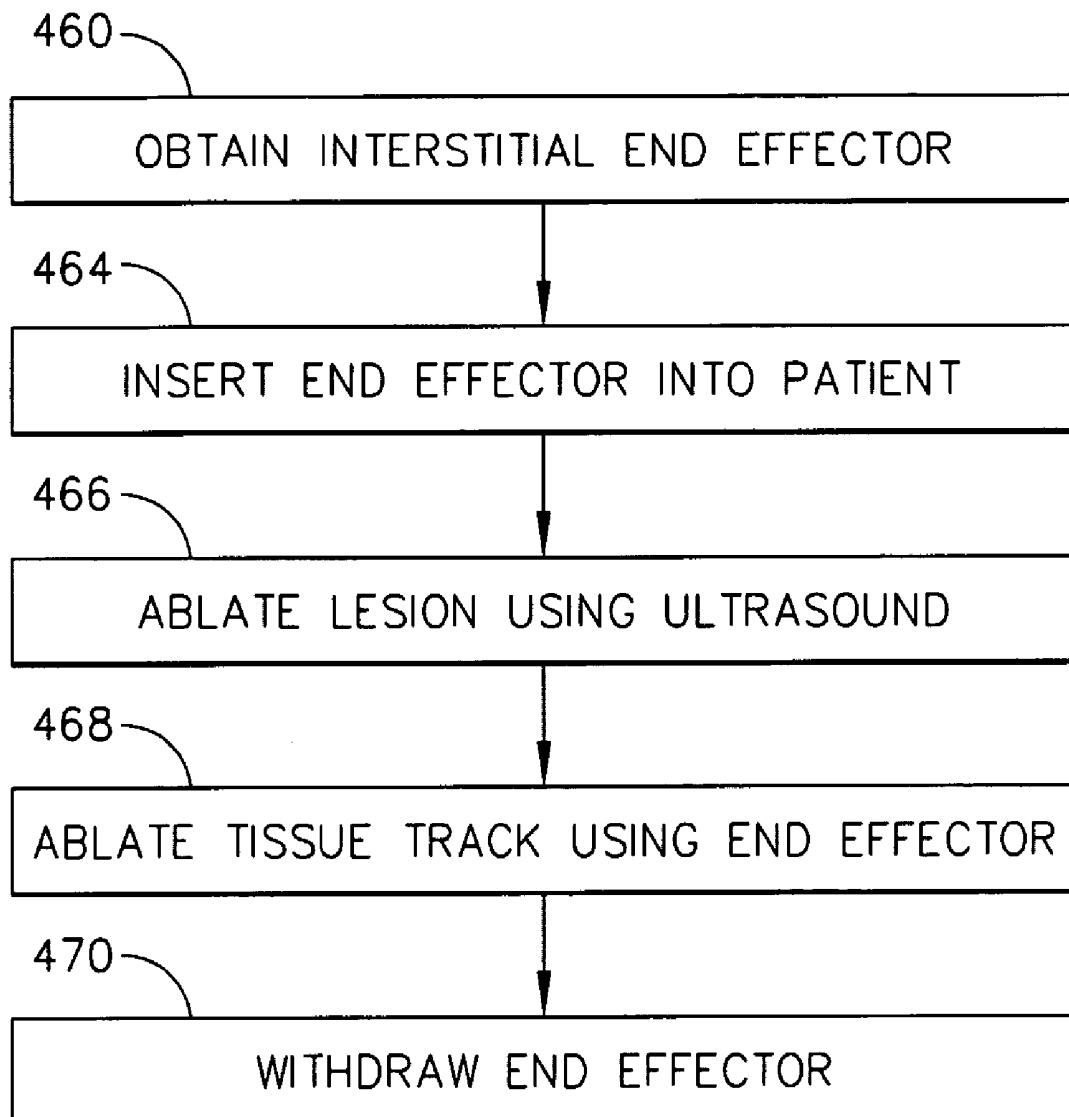

FIG. 5

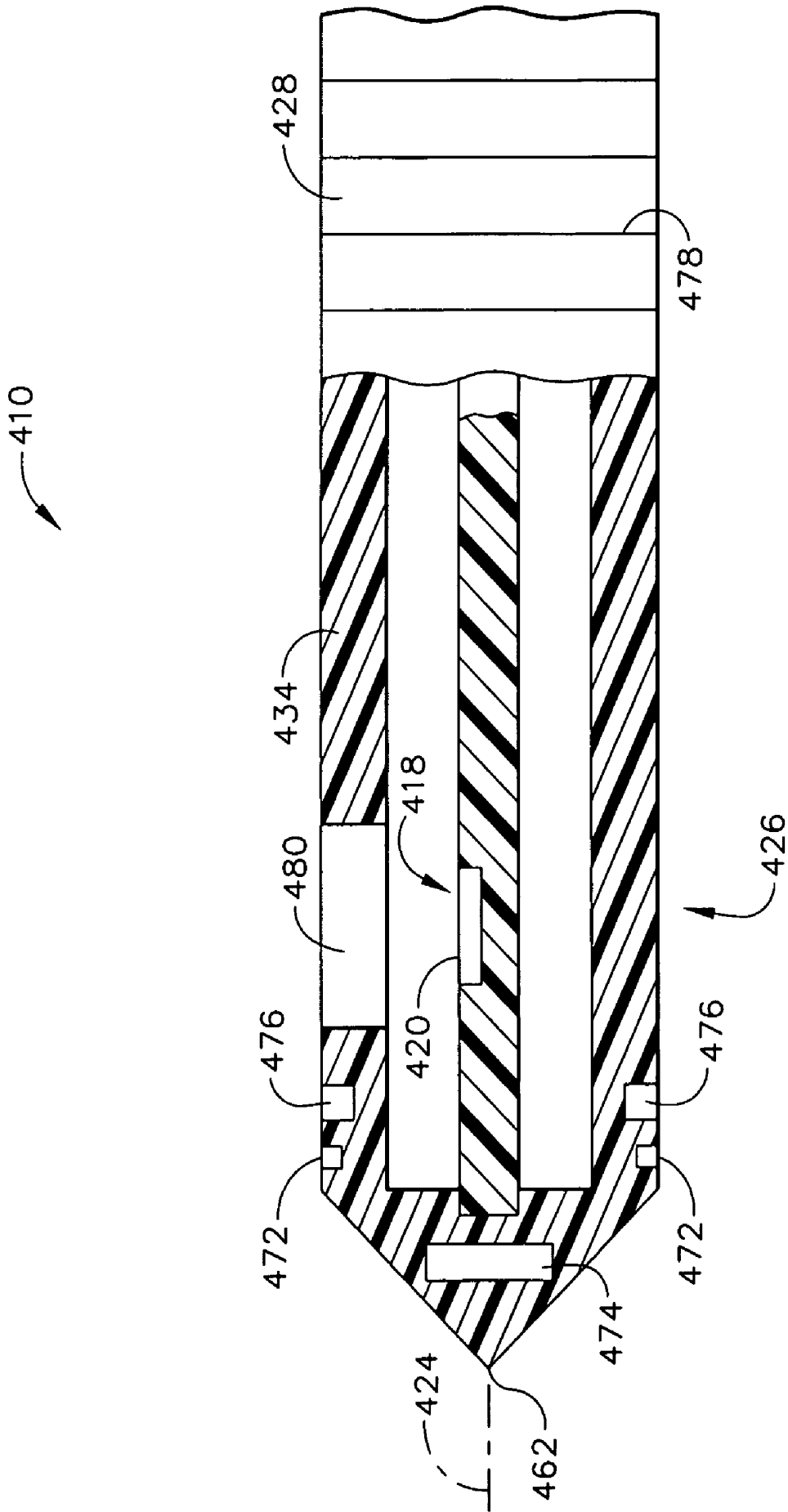

FIG. 6

## ULTRASOUND MEDICAL SYSTEM AND METHOD

### FIELD OF THE INVENTION

[0001] The present invention relates generally to ultrasound, and more particularly to ultrasound medical systems and methods.

### BACKGROUND OF THE INVENTION

[0002] Known medical methods include using ultrasound imaging (at low power) of patients to identify patient tissue for medical treatment and include using ultrasound (at high power) to ablate identified patient tissue by heating the tissue.

[0003] Known ultrasound medical systems and methods include deploying an ultrasound end effector having an ultrasound transducer outside the body to break up kidney stones inside the body, endoscopically inserting an ultrasound end effector having an ultrasound transducer in the rectum to medically destroy prostate cancer, laparoscopically inserting an ultrasound end effector having an ultrasound transducer in the abdominal cavity to medically destroy a cancerous liver tumor, intravenously inserting a catheter ultrasound end effector having an ultrasound transducer into a vein in the arm and moving the catheter to the heart to medically destroy diseased heart tissue, and interstitially inserting a needle ultrasound end effector having an ultrasound transducer needle into the tongue to medically destroy tissue to reduce tongue volume to reduce snoring.

[0004] Rotatable ultrasound end effectors are known wherein an ultrasound transducer is non-rotatably attached to a shaft whose distal end is circumferentially and longitudinally surrounded by a sheath having a longitudinal axis and having an acoustic window. Water between the shaft and the sheath provides acoustic coupling between the ultrasound transducer and the acoustic window. The shaft is rotatable about the longitudinal axis with respect to the sheath. The sheath is non-rotatably attached to a handpiece.

[0005] Known medical systems and methods include deploying a radio-frequency (RF) end effector having an RF electrode to thermally ablate patient tissue and to take tissue electric impedance and tissue temperature measurements using electrodes integrated into the shaft or into a tine which also helps stabilize the RF end effector in patient tissue.

[0006] Still, scientists and engineers continue to seek improved ultrasound medical systems and methods.

### SUMMARY OF THE INVENTION

[0007] An embodiment of the invention is an ultrasound medical system including an ultrasound end effector. The ultrasound end effector has an exterior surface, includes a medical ultrasound transducer assembly having at least one medical-treatment ultrasound transducer, and includes at least one tine. The at-least-one tine is deployable to extend away from the exterior surface into patient tissue to provide at least some stabilization of the ultrasound end effector with respect to patient tissue and is retrievable to retract back toward the exterior surface.

[0008] Several benefits and advantages are obtained from one or more of the embodiments and methods of the invention. In one example, having an ultrasound end effector

with a medical-treatment ultrasound transducer and a deployable tine provides at least some stabilization of the ultrasound end effector with respect to patient tissue providing more precise treatment from the medical-treatment ultrasound transducer.

[0009] The present invention has, without limitation, application in conventional interstitial, endoscopic, laparoscopic, and open surgical instrumentation as well as application in robotic-assisted surgery.

### BRIEF DESCRIPTION OF THE FIGURES

[0010] FIG. 1 is a perspective view of a first embodiment of the present invention showing an ultrasound medical system which includes an end effector, a handpiece, and a controller;

[0011] FIG. 2 is a schematic cross-sectional view of a first embodiment of the end effector and the handpiece of the ultrasound medical system of FIG. 1 showing a medical ultrasound transducer assembly and two non-ultrasound tissue-property-measuring sensors;

[0012] FIG. 3 is a view, as in FIG. 2, but of a second embodiment of a handpiece and of an end effector having a medical ultrasound transducer assembly and two tines;

[0013] FIG. 4 is a view, as in FIG. 2, but of a third embodiment of an end effector having a medical ultrasound transducer assembly supported by a shaft and having a surrounding sheath, wherein the sheath includes two balloon portions;

[0014] FIG. 5 is a block diagram view of a method of the invention for ultrasonically treating a lesion in a patient; and

[0015] FIG. 6 is a schematic view, partially in cross-section, of a fourth embodiment of an end effector which has a medical-treatment ultrasound transducer and three end-effector-tissue-track ablation devices and which can be used in one employment of the method of FIG. 5.

### DETAILED DESCRIPTION OF THE INVENTION

[0016] Before explaining the present invention in detail, it should be noted that the invention is not limited in its application or use to the details of construction and arrangement of parts and/or steps illustrated in the accompanying drawings and description. The illustrative embodiments and methods of the invention may be implemented or incorporated in other embodiments, methods, variations and modifications, and may be practiced or carried out in various ways. Furthermore, unless otherwise indicated, the terms and expressions employed herein have been chosen for the purpose of describing the illustrative embodiments and methods of the present invention for the convenience of the reader and are not for the purpose of limiting the invention.

[0017] It is understood that any one or more of the following-described embodiments, methods, examples, etc. can be combined with any one or more of the other following-described embodiments, methods, examples, etc.

[0018] Referring now to FIGS. 1-2 of the drawings, a first embodiment of the present invention is an ultrasound medical system 110 comprising an ultrasound end effector 112 and at least one non-ultrasound tissue-property-measuring

sensor 114 and 116. The ultrasound end effector 112 includes a medical ultrasound transducer assembly 118 having at least one medical-treatment ultrasound transducer 120. The at-least-one non-ultrasound tissue-property-measuring sensor 114 and 116 is supported by the ultrasound end effector 112 and is disposable in contact with patient tissue 122.

[0019] It is noted that a medical-treatment ultrasound transducer includes a medical-treatment-only ultrasound transducer and a medical-imaging-and-treatment ultrasound transducer. In one arrangement, an ultrasound transducer has a single transducer element, and in another arrangement, an ultrasound transducer has a plurality (also called an array) of transducer elements. It is also noted that a medical ultrasound transducer assembly having at least one medical-treatment ultrasound transducer can also have at least one medical-imaging ultrasound transducer.

[0020] In one example of the embodiment of FIGS. 1-2, the ultrasound end effector 112 includes a longitudinal axis 124. In this example, the at-least-one non-ultrasound tissue-property-measuring sensor 114 and 116 includes a first non-ultrasound tissue-property-measuring sensor 114 and a second non-ultrasound tissue-property-measuring sensor 116. The at-least-one medical-treatment ultrasound transducer 120 is disposed longitudinally between the first and second non-ultrasound tissue-property-measuring sensors 114 and 116.

[0021] In one variation of the embodiment of FIGS. 1-2, the at-least-one non-ultrasound tissue-property-measuring sensor (e.g., 114) measures tissue temperature. In one modification, the at-least-one non-ultrasound tissue-property-measuring sensor (e.g., 114) is chosen from the group consisting of a thermistor, a thermocouple, and combinations thereof. In another variation, the at-least-one non-ultrasound tissue-property-measuring sensor (e.g., 116) measures tissue electric impedance. In one modification, the at-least-one non-ultrasound tissue-property-measuring sensor (e.g., 116) is chosen from the group consisting of a monopolar electrode, a bipolar electrode, and combinations thereof. It is noted that tissue temperature and/or tissue electric impedance is a measure of the degree of ultrasonic ablation of patient tissue, as can be appreciated by those skilled in the art.

[0022] In one construction of the embodiment of FIGS. 1-2, the ultrasound end effector 112 is an ultrasound interstitial end effector 126 which is interstitially insertable into patient tissue 122 and which has an exterior surface 128. The at-least-one non-ultrasound tissue-property-measuring sensor 114 and 116 is attached to the ultrasound interstitial end effector 126 and is fixedly disposed substantially flush with the exterior surface 128. In one arrangement, the exterior surface 128 includes at least one balloon portion 130 and 132 which is expandable and contractible and which is expandable against patient tissue 122 to provide at least some stabilization of the ultrasound interstitial end effector 126 with respect to patient tissue 122. In one variation, the exterior surface 128 is the exterior surface of a sheath 134 and has first and second balloon portions 130 and 132, wherein the first balloon portion 130 surrounds the medical ultrasound transducer assembly 118 and acts as an acoustic window, and wherein the second balloon portion 132 is longitudinally spaced apart from the medical ultrasound transducer assembly 118. An acoustic coupling medium,

such as water, is disposable between the medical ultrasound transducer assembly 118 and the first balloon portion 130 and has been omitted from FIG. 2 for clarity. In one modification, the first balloon portion 130 is omitted and the sheath 134 terminates before the medical ultrasound transducer assembly 118 which is exposed to patient tissue. In another modification, the second balloon portion 132 is omitted. In one employment, the at-least-one balloon portion 130 and 132 is contracted during tissue insertion and withdrawal of the ultrasound interstitial end effector 126. Other constructions, arrangements, variations, and modifications are left to the artisan.

[0023] In one enablement of the embodiment of FIGS. 1-2, the ultrasound end effector 112 is an ultrasound interstitial end effector 126 which is interstitially insertable into patient tissue 122 and which has an exterior surface 128. In this enablement, the at-least-one non-ultrasound tissue-property-measuring sensor 114 and 116 is deployable to extend away from the exterior surface into patient tissue 128 to provide at least some stabilization of the ultrasound interstitial end effector 126 with respect to patient tissue 122 and is retrievable to retract back toward the exterior surface 128. In one arrangement, the at-least-one non-ultrasound tissue-property-measuring sensor 114 and 116 is storable inside the exterior surface.

[0024] In one implementation of the embodiment of FIGS. 1-2, the ultrasound medical system 110 also includes a handpiece 136 operatively connected to the ultrasound end effector 112. The ultrasound end effector 112 has a longitudinal axis 124 and a shaft 138, and the medical ultrasound transducer assembly 118 is supported by the shaft 138. The shaft 138 is rotatable with respect to the handpiece 136 about the longitudinal axis 124 and is supported by bearings 139. In one variation, a motor 140 rotates the shaft 138. In one arrangement, the ultrasound medical system 110 includes a controller 142 operatively connected to the handpiece 136 via a cable 144.

[0025] A second embodiment of the present invention, shown in FIG. 3, is an ultrasound medical system 210 comprising an ultrasound end effector 226. The ultrasound end effector 226 has an exterior surface 228. The ultrasound end effector 226 includes a medical ultrasound transducer assembly 218 having at least one medical-treatment ultrasound transducer 220, and includes at least one tine 246 and 248. The at-least-one tine 246 and 248 is deployable to extend away from the exterior surface into patient tissue to provide at least some stabilization of the ultrasound end effector 226 with respect to patient tissue and is retrievable to retract back toward the exterior surface 228.

[0026] In one example of the embodiment of FIG. 3, the ultrasound end effector 226 is insertable into a patient. In one variation, the ultrasound end effector 226 is an ultrasound interstitial end effector which is interstitially insertable into patient tissue. In other variations, the ultrasound end effector is insertable into a patient in an endoscopic, laparoscopic, and/or open surgical manner. In another example, the ultrasound end effector is disposable on the outside of a patient. Other examples and variations are left to the artisan.

[0027] In one enablement of the embodiment of FIG. 3, the at-least-one tine 246 and 248 includes a plurality of tines. In one example of the embodiment of FIG. 3, the at-least-

one tine **246** and **248** is storable inside the exterior surface. It is noted that construction of deployable tines **246** and **248** in an ultrasound end effector **226** is within the level of skill of the artisan. In one arrangement, such deployment is accomplished using one or more of cables, levers, motors **249**, gearing, push rods and the like to move a tine partially out of, and back into, a lumen in the end effector. In one choice of materials, the tine comprises or consists essentially of Nitinol wire or nichrome wire.

[0028] In one employment of the embodiment of **FIG. 3**, the at-least-one tine (e.g., **246**) acts as an element chosen from the group consisting of an electrode, a thermistor, a thermocouple, an acoustic reflector, an acoustic absorber, an acoustic emitter, an acoustic receiver, a radio-frequency (RF) heater, a resistive heater, and combinations thereof. In another employment, the at-least-one tine (e.g., **248**) includes a component **250** chosen from the group consisting of an electrode, a thermistor, a thermocouple, an acoustic reflector, an acoustic absorber, an acoustic emitter, an acoustic receiver, a radio-frequency (RF) heater, a resistive heater, and combinations thereof.

[0029] The embodiment, examples, constructions, implementations, etc. of the embodiment of **FIGS. 1-2** are equally applicable to the embodiment, constructions, implementations, etc. of **FIG. 3**. In one construction of the embodiment of **FIG. 3**, the exterior surface **228** is like the exterior surface **128** of a previously-illustrated and described construction of the embodiment of **FIGS. 1-2** including at least one balloon portion which is expandable and contractible, and which is expandable against patient tissue to provide at least some stabilization of the ultrasound end effector with respect to patient tissue. In one implementation of the embodiment of **FIG. 3**, the ultrasound medical system **210** also includes, like a previously-illustrated and described implementation of the embodiment of **FIGS. 1-2**, a handpiece operatively connected to the ultrasound end effector, wherein the ultrasound end effector has a longitudinal axis and a shaft, wherein the medical ultrasound transducer assembly is supported by the shaft, and wherein the shaft is rotatable with respect to the handpiece about the longitudinal axis.

[0030] One method, using the embodiment of **FIG. 3** and enablements, examples, employments, and constructions thereof, is for ultrasonically treating a lesion in a patient and includes steps a) through f). Step a) includes obtaining the ultrasound medical system **210**. Step b) includes inserting the ultrasound end effector **226** into patient tissue. Step c) includes deploying the plurality of tines **246** and **248** to extend sway from the exterior surface **228** into the patient tissue. Step d) includes ultrasonically ablating the lesion using the at-least-one medical-treatment ultrasound transducer **220**. Step e) includes retrieving the plurality of tines **246** and **248** to retract back toward the exterior surface and storing the plurality of tines **246** and **248** inside the exterior surface **228**. Step f) includes withdrawing the ultrasound end effector **226** from the patient tissue. Another method also includes the step of employing the plurality of tines **246** and **248** to each act as the element or using each component **250**. An additional method also includes the step of expanding the at-least-one balloon portion against patient tissue and contracting the at-least-one balloon portion.

[0031] A third embodiment of the present invention, shown in **FIG. 4**, is an ultrasound medical system **310**

comprising an ultrasound end effector **326** including a shaft **338**, a sheath **334**, and a medical ultrasound transducer assembly **318**. The medical ultrasound transducer assembly **318** is supported by the shaft **338** and has at least one medical-treatment ultrasound transducer **320**. The sheath **334** surrounds the shaft **338**. The sheath **334** includes at least one balloon portion **330** and **332** which is expandable against patient tissue to provide at least some stabilization of the ultrasound end effector **326** with respect to patient tissue.

[0032] In one example of the embodiment of **FIG. 4**, the ultrasound end effector **326** is insertable into a patient. In one variation, the ultrasound end effector **326** is an ultrasound interstitial end effector which is interstitially insertable into patient tissue. In other variations, the ultrasound end effector is insertable into a patient in an endoscopic, laparoscopic, and/or open surgical manner. In another example, the ultrasound end effector is disposable on the outside of a patient. Other examples and variations are left to the artisan.

[0033] In one construction of the embodiment of **FIG. 3**, the ultrasound end effector **326** has a longitudinal axis **324**, and the at-least-one balloon portion (e.g., **330**) acts as an acoustic window and is disposed to longitudinally overlap the at-least-one medical-treatment ultrasound transducer **320**. In one variation of this construction, the at-least-one balloon portion (e.g., **330**) includes at least one through hole **352**. In one modification, the at-least-one balloon portion (e.g., **330**) includes a plurality of through holes **352** creating a "weeping" balloon portion, wherein some of the acoustic coupling medium inside the sheath **334** extends and/or flows outside the sheath acoustic window providing improved acoustic coupling between the at-least-one medical-treatment ultrasound transducer **320** and patient tissue.

[0034] In one arrangement of the embodiment of **FIG. 3**, the at-least-one balloon portion (e.g., **330**) includes at least one through hole **352** and the ultrasound end effector **326** is adapted to dispense a drug **354** through the at-least-one through hole **352** to patient tissue. In one variation, the drug **354** is carried in a liquid acoustic coupling medium **356**, such as water, disposed between the medical ultrasound transducer assembly **318** and the at-least-one balloon portion **330** whose pressure is controlled (such as by a pump in a handpiece operatively connected to the ultrasound end effector) to expand and contract the at-least-one balloon portion **330**. In one variation, the drug **354** is at least potentiated (i.e., has its medical effect increased and/or activated) by ultrasound emitted from the at-least-one medical-treatment ultrasound transducer **320**.

[0035] In the same or another arrangement of the embodiment of **FIG. 3**, the ultrasound end effector **326** has a longitudinal axis **324**, and the at-least-one balloon portion (e.g., **332**) is disposed longitudinally apart from the at-least-one medical-treatment ultrasound transducer **320**. In one variation of the embodiment of **FIG. 3**, the at-least-one balloon portion (e.g., **330**) is a fully-circumferential balloon portion. In a different variation, the at-least-one balloon portion (e.g., **332**) is a blister balloon portion. In one example of the embodiment of **FIG. 3**, the at-least-one balloon portion **330** and **332** includes an outside surface **358** having a roughness average at least equal to 0.005-inch. In one variation, the outside surface includes ribs. Such surface roughness improves stabilization of the ultrasound end

effector **326** with respect to patient tissue when the at-least-one balloon portion **330** and **332** is expanded against the patient tissue.

[0036] The embodiments, constructions, implementations, etc. of the embodiments of **FIGS. 1-2** and **3** are equally applicable to the embodiment, constructions, implementations, etc. of the embodiment of **FIG. 4**. In one implementation of the embodiment of **FIG. 3**, the ultrasound medical system **310** also includes a controller, like the controller of the previously-illustrated and described arrangement of the embodiment of **FIGS. 1-2**, wherein the controller is operatively connected to the medical ultrasound transducer assembly, wherein the medical ultrasound transducer assembly is a medical-imaging-and-treatment ultrasound transducer assembly, and wherein the controller determines if the at-least-one balloon portion is acoustically coupled to, or acoustically decoupled from, patient tissue from ultrasonically imaging a balloon-tissue area using the medical-imaging-and-treatment ultrasound transducer assembly.

[0037] One method of the invention for ultrasonically treating a lesion in a patient is shown in block diagram form in **FIG. 5**, and an embodiment of an ultrasound medical system which can be used in performing the method is shown in **FIG. 6**. The method includes steps a) through e). Step a) is labeled as "Obtain Interstitial End Effector" in block **460** of **FIG. 5**. Step a) includes obtaining an interstitial end effector **426** including a distal end **462** and including a medical ultrasound transducer assembly **418** having at least one medical-treatment ultrasound transducer **420** and at least one end-effector-tissue-track ablation device **472**, **474** and **476**. It is noted that the distal end of an interstitial end effector is an end having a tissue-piercing tip. Step b) is labeled as "Insert End Effector Into Patient" in block **464** of **FIG. 5**. Step b) includes inserting the interstitial end effector **426** into the patient creating a tissue track which is surrounded by patient tissue and which ends at the distal end **462** of the inserted interstitial end effector **426**. Step c) is labeled as "Ablate Lesion Using Ultrasound" in block **466** of **FIG. 5**. Step c) includes ultrasonically ablating the lesion using the at-least-one medical-treatment ultrasound transducer **420**. Step d) is labeled as "Ablate Tissue Track Using End Effector" in block **468** of **FIG. 5**. Step d) includes using the at-least-one end-effector-tissue-track ablation device **472**, **474** and **476** to ablate the patient tissue surrounding the tissue track along substantially the entire tissue track. Step e) is labeled as "Withdraw End Effector" in block **470** of **FIG. 5**. Step e) includes withdrawing the interstitial end effector **426** from the patient.

[0038] It is noted that creating a tissue track requires that the interstitial end effector **426** be interstitially inserted into patient tissue. It is also noted that the interstitial end effector **426** can be equipped with a retractable tip shield (not shown) for initial endoscopic or laparoscopic patient entry followed by interstitial insertion into patient tissue.

[0039] In one extension of the method of **FIG. 5**, there is included the step of using the at-least-one end-effector-tissue-track ablation device (e.g., **474**) to ablate the patient tissue at the distal end **462** of the inserted interstitial end effector **426**.

[0040] In one implementation of the method of **FIG. 5**, the at-least-one end-effector-tissue-track ablation device (e.g., **474**) includes a non-ultrasound energy source, and step d)

uses the non-ultrasound energy source to ablate the patient tissue surrounding the tissue track. In one variation, the non-ultrasound energy source is chosen from the group consisting of a resistive heat energy source, a hot liquid energy source, a monopolar radio-frequency (RF) energy source, a bipolar radio-frequency (RF) energy source, a capacitive heat energy source, a microwave energy source, and combinations thereof.

[0041] In another implementation of the method, the at-least-one end-effector-tissue-track ablation device (e.g., **476**) includes a tissue-ablating chemical agent, and step d) uses the tissue-ablating chemical agent to ablate the patient tissue surrounding the tissue track. In one variation, the tissue-ablating chemical agent is chosen from the group consisting of fibrin, alcohol, an acidic fluid, a chemotherapeutic agent, and combinations thereof.

[0042] In a further implementation of the method, step d) uses the medical ultrasound transducer assembly **418** to ultrasonically ablate the patient tissue surrounding the tissue track. In one variation, step d) ultrasonically ablates at a higher ultrasound frequency than does step c).

[0043] In the same or another extension of the method of **FIG. 5**, there is included the step of monitoring (such as for acoustic coupling and/or for tissue ablation) the patient tissue surrounding the tissue track during step d). In one variation, the monitoring is chosen from the group consisting of B-mode ultrasonic image monitoring, tissue temperature monitoring, tissue electric impedance, and combinations thereof.

[0044] In the same or another extension of the method of **FIG. 5**, there are included, after step b) and before step c), the step of stabilizing (such as by using a balloon, a tine and/or suction) the interstitial end effector **426** with respect to the patient tissue surrounding the tissue track and, after step c) and before step d), the step of releasing the stabilizing of the interstitial end effector **426** with respect to the patient tissue surrounding the tissue track.

[0045] In one application of the method of **FIG. 5**, step e) includes stepwise withdrawing the interstitial end effector **426** from the patient using a plurality of positional steps, and step d) includes ablating the patient tissue surrounding the tissue track for a predetermined time with the interstitial end effector at each positional step.

[0046] A fourth embodiment of the present invention, shown in **FIG. 6**, is an ultrasound medical system **410** comprising an interstitial end effector **426** which is interstitially insertable into patient tissue, which includes at least one medical-treatment ultrasound transducer **420**, and which includes at least one end-effector-tissue-track ablation device **472**, **474** and **476**.

[0047] In one enablement of the embodiment of **FIG. 6**, the ultrasound medical system **410** includes a controller (such as the controller **142** illustrated in **FIG. 1**) which is operatively connected to the at-least-one medical-treatment ultrasound transducer **420** to ultrasonically ablate a lesion in patient tissue of the patient and which is operatively connected to the at-least-one end-effector-tissue-track ablation device **472**, **474** and **476** to ablate patient tissue surrounding the interstitial end effector **426** during withdrawal of the interstitial end effector **426** from the patient.

[0048] In one application of the embodiment of FIG. 6, the at-least-one end-effector-tissue-track ablation device 472, 474, 476 includes a cylindrical ultrasound transducer 472. In the same or a different application, the at-least-one end-effector-tissue-track ablation device and the at-least-one medical-treatment ultrasound transducer are a single rotatable ultrasound transducer (such as ultrasound transducer 420 made rotatable such as in a previously illustrated and described implementation of the embodiment of FIGS. 1-2). Other applications of an end-effector-tissue-track ablation device involving ultrasound are left to the artisan.

[0049] In another application of the embodiment of FIG. 6, the at-least-one end-effector-tissue-track ablation device 472, 474 and 476 includes a device 474 which uses a non-ultrasound energy source. In one variation, the non-ultrasound energy source is chosen from the group consisting of a resistive heat energy source, a hot liquid energy source, a monopolar radio-frequency (RF) energy source, a bipolar radio-frequency (RF) energy source, a capacitive heat energy source, a microwave energy source, and combinations thereof.

[0050] In a further application of the embodiment of FIG. 6, the at-least-one end-effector-tissue-track ablation device 472, 474 and 476 includes a device 476 which releases a tissue-ablating chemical agent. In one variation, the tissue-ablating chemical agent is chosen from the group consisting of fibrin, alcohol, an acidic fluid, a chemotherapeutic agent, and combinations thereof.

[0051] In one construction of the embodiment of FIG. 6, the interstitial end effector 426 has a length and an exterior surface 428 and includes position markings 478 on the exterior surface 428 along at least a portion of its length. Such position markings allow a user to withdraw the interstitial end effector 426 from patient tissue in positional steps while ablating patient tissue surrounding the end-effector tissue track for a predetermined dwell time at each positional step. In the same or a different construction, the interstitial end effector 426 has a longitudinal axis 424 and a distal end 462, and wherein the at-least-one end-effector-tissue-track ablation device 472, 474 and 476 includes an end-effector-tissue-track ablation device (such as 474) which is disposed proximate the distal end 462. It is noted that the distal end of an interstitial end effector is an end having a tissue-piercing tip. In the same or a different construction, the interstitial end effector 426 includes a tissue-ablating component (such as 474) adapted (such as by having a resistive heat energy source) to ablate (such as to thermally ablate) patient tissue longitudinally forward of the distal end 462.

[0052] In one variation, the ultrasound interstitial end effector includes a sheath 434 surrounding the medical-treatment ultrasound transducer 120 and having an acoustic window 480. In one modification, the entire sheath acts as an acoustic window. In another modification, the acoustic window is a thinner portion of the sheath. In a further modification, the acoustic window is a separate material(s) from the material(s) of the non-acoustic-window portion(s) of the sheath. Acoustic window component materials are known to those skilled in the art. Other modifications are left to the artisan.

[0053] It is noted that the embodiments, constructions, implementations, etc. of the embodiments of FIGS. 1-2, 3 and 4 are equally applicable to the embodiment, constructions, implementations, etc. of the embodiment of FIG. 6.

[0054] Several benefits and advantages are obtained from one or more of the embodiments and methods of the invention. In one example, having an ultrasound end effector with a medical-treatment ultrasound transducer and a deployable tine provides at least some stabilization of the ultrasound end effector with respect to patient tissue providing more precise treatment from the medical-treatment ultrasound transducer.

[0055] While the present invention has been illustrated by a description of several embodiments and methods, it is not the intention of the applicants to restrict or limit the spirit and scope of the appended claims to such detail. Numerous other variations, changes, and substitutions will occur to those skilled in the art without departing from the scope of the invention. For instance, the ultrasound medical system of the invention has application in robotic assisted surgery taking into account the obvious modifications of such systems, components and methods to be compatible with such a robotic system. It will be understood that the foregoing description is provided by way of example, and that other modifications may occur to those skilled in the art without departing from the scope and spirit of the appended claims.

What is claimed is:

1. An ultrasound medical system comprising an ultrasound end effector, wherein the ultrasound end effector has an exterior surface, includes a medical ultrasound transducer assembly having at least one medical-treatment ultrasound transducer, and includes at least one tine, and wherein the at-least-one tine is deployable to extend away from the exterior surface into patient tissue to provide at least some stabilization of the ultrasound end effector with respect to patient tissue and is retrievable to retract back toward the exterior surface.

2. The ultrasound medical system of claim 1, wherein the at-least-one tine is storable inside the exterior surface.

3. The ultrasound medical system of claim 1, wherein the at-least-one tine acts as an element chosen from the group consisting of an electrode, a thermistor, a thermocouple, an acoustic reflector, an acoustic absorber, an acoustic emitter, an acoustic receiver, a radio-frequency (RF) heater, a resistive heater, and combinations thereof.

4. The ultrasound medical system of claim 1, wherein the at-least-one tine includes a component chosen from the group consisting of an electrode, a thermistor, a thermocouple, an acoustic reflector, an acoustic absorber, an acoustic emitter, an acoustic receiver, a radio-frequency (RF) heater, a resistive heater, and combinations thereof.

5. The ultrasound medical system of claim 1, wherein the exterior surface includes at least one balloon portion which is expandable and contractible, and which is expandable against patient tissue to provide at least some stabilization of the ultrasound end effector with respect to patient tissue.

6. The ultrasound medical system of claim 5, also including a handpiece operatively connected to the ultrasound end effector, wherein the ultrasound end effector has a longitudinal axis and a shaft, wherein the medical ultrasound transducer assembly is supported by the shaft, and wherein the shaft is rotatable with respect to the handpiece about the longitudinal axis.

7. The ultrasound medical system of claim 1, also including a handpiece operatively connected to the ultrasound end effector, wherein the ultrasound end effector has a longitudinal axis and a shaft, wherein the medical ultrasound

transducer assembly is supported by the shaft, and wherein the shaft is rotatable with respect to the handpiece about the longitudinal axis.

**8.** An ultrasound medical system comprising an ultrasound interstitial end effector, wherein the ultrasound interstitial end effector is interstitially insertable into patient tissue, has an exterior surface, includes a medical ultrasound transducer assembly having at least one medical-treatment ultrasound transducer, and includes a plurality of tines, wherein the plurality of tines are deployable to extend away from the exterior surface into patient tissue to provide at least some stabilization of the ultrasound interstitial end effector with respect to patient tissue and are retrievable to retract back toward the exterior surface, and wherein the plurality of tines are storable inside the exterior surface.

**9.** The ultrasound medical system of claim 8, wherein the plurality of tines each act as an element chosen from the group consisting of an electrode, a thermistor, a thermocouple, an acoustic reflector, an acoustic absorber, an acoustic emitter, an acoustic receiver, a radio-frequency (RF) heater, a resistive heater, and combinations thereof.

**10.** The ultrasound medical system of claim 8, wherein the plurality of tines each include a component chosen from the group consisting of an electrode, a thermistor, a thermocouple, an acoustic reflector, an acoustic absorber, an acoustic emitter, an acoustic receiver, a radio-frequency (RF) heater, a resistive heater, and combinations thereof.

**11.** The ultrasound medical system of claim 8, wherein the exterior surface includes at least one balloon portion which is expandable and contractible, and which is expandable against patient tissue to provide at least some stabilization of the ultrasound interstitial end effector with respect to patient tissue.

**12.** The ultrasound medical system of claim 11, also including a handpiece operatively connected to the ultrasound interstitial end effector, wherein the ultrasound interstitial end effector has a longitudinal axis and a shaft, wherein the medical ultrasound transducer assembly is supported by the shaft, and wherein the shaft is rotatable with respect to the handpiece about the longitudinal axis.

**13.** The ultrasound medical system of claim 8, also including a handpiece operatively connected to the ultrasound interstitial end effector, wherein the ultrasound interstitial end effector has a longitudinal axis and a shaft, wherein the medical ultrasound transducer assembly is supported by the shaft, and wherein the shaft is rotatable with respect to the handpiece about the longitudinal axis.

**14.** A method for ultrasonically treating a lesion in a patient comprising the steps of:

- a) obtaining the ultrasound medical system of claim 8;
- b) inserting the ultrasound interstitial end effector into patient tissue;
- c) deploying the at-least-one tine to extend sway from the exterior surface into the patient tissue;
- d) ultrasonically ablating the lesion using the at-least-one medical-treatment ultrasound transducer;
- e) retrieving the at-least-one tine to retract back toward the exterior surface and storing the at-least-one tine inside the exterior surface; and
- f) withdrawing the ultrasound interstitial end effector from the patient tissue.

**15.** A method for ultrasonically treating a lesion in a patient comprising the steps of:

- a) obtaining the ultrasound medical system of claim 9;
- b) inserting the ultrasound interstitial end effector into patient tissue;
- c) deploying the plurality of tines to extend sway from the exterior surface into the patient tissue;
- d) ultrasonically ablating the lesion using the at-least-one medical-treatment ultrasound transducer;
- e) employing the plurality of tines to each act as the element;
- f) retrieving the plurality of tines to retract back toward the exterior surface and storing the plurality of tines inside the exterior surface; and
- g) withdrawing the ultrasound interstitial end effector from the patient tissue.

**16.** A method for ultrasonically treating a lesion in a patient comprising the steps of:

- a) obtaining the ultrasound medical system of claim 10;
- b) inserting the ultrasound interstitial end effector into patient tissue;
- c) deploying the plurality of tines to extend sway from the exterior surface into the patient tissue;
- d) ultrasonically ablating the lesion using the at-least-one medical-treatment ultrasound transducer;
- e) using each component;
- f) retrieving the plurality of tines to retract back toward the exterior surface and storing the plurality of tines inside the exterior surface; and
- g) withdrawing the ultrasound interstitial end effector from the patient tissue.

**17.** A method for ultrasonically treating a lesion in a patient comprising the steps of:

- a) obtaining the ultrasound medical system of claim 11;
- b) inserting the ultrasound interstitial end effector into patient tissue;
- c) deploying the plurality of tines to extend sway from the exterior surface into the patient tissue;
- d) expanding the at-least-one balloon portion against the patient tissue;
- e) ultrasonically ablating the lesion using the at-least-one medical-treatment ultrasound transducer;
- f) contracting the at-least-one balloon portion;
- g) retrieving the plurality of tines to retract back toward the exterior surface and storing the plurality of tines inside the exterior surface; and
- h) withdrawing the ultrasound interstitial end effector from the patient tissue.

专利名称(译)	超声医疗系统和方法		
公开(公告)号	<a href="#">US20050261587A1</a>	公开(公告)日	2005-11-24
申请号	US10/850041	申请日	2004-05-20
[标]申请(专利权)人(译)	MAKIN因德尔R 5 MAST T d设定 斯雷顿MICHAEL ^ h BARTHE PETER摹 梅瑟利JEFFREYD FAIDI克瓦		
申请(专利权)人(译)	MAKIN因德尔R 5 MAST T d设定 斯雷顿MICHAEL ^ h BARTHE PETER摹 梅瑟利JEFFREYD FAIDI克瓦		
当前申请(专利权)人(译)	爱惜康内镜手术, INC.		
[标]发明人	MAKIN INDER RAJ S MAST T DOUGLAS SLAYTON MICHAEL H BARTHE PETER G MESSERLY JEFFREY D FAIDI WASEEM		
发明人	MAKIN, INDER RAJ S. MAST, T. DOUGLAS SLAYTON, MICHAEL H. BARTHE, PETER G. MESSERLY, JEFFREY D. FAIDI, WASEEM		
IPC分类号	A61B8/00 A61B8/12 A61B8/14 A61B17/22 A61B17/34		
CPC分类号	A61B17/22012 A61B2017/3488 A61B2017/3484 A61B17/2202 A61B8/4281		
外部链接	<a href="#">Espacenet</a> <a href="#">USPTO</a>		

摘要(译)

超声医疗系统包括超声末端执行器。超声末端执行器具有外表面，包括具有至少一个医疗超声换能器的医疗超声换能器组件，并且包括至少一个叉齿。至少一个尖齿可展开以远离外表面延伸到患者组织中，以提供超声末端执行器相对于患者组织的至少一些稳定性，并且可回收以朝向外表面缩回。

