

US009980700B2

(12) **United States Patent**
Gubbini et al.

(10) **Patent No.:** **US 9,980,700 B2**
(45) **Date of Patent:** **May 29, 2018**

(54) **ULTRASOUND APPARATUS COVER**

(75) Inventors: **Alessandro Gubbini**, State College, PA (US); **Bradley Nelson**, Boalsburg, PA (US)

(73) Assignee: **Sound Technology, Inc.**, State College, PA (US)

(*) Notice: Subject to any disclaimer, the term of this patent is extended or adjusted under 35 U.S.C. 154(b) by 348 days.

(21) Appl. No.: **14/234,063**

(22) PCT Filed: **Jul. 22, 2011**

(86) PCT No.: **PCT/US2011/044798**

§ 371 (c)(1),
(2), (4) Date: **Jan. 21, 2014**

(87) PCT Pub. No.: **WO2013/015769**

PCT Pub. Date: **Jan. 31, 2013**

(65) **Prior Publication Data**

US 2014/0163382 A1 Jun. 12, 2014

(51) **Int. Cl.**
A61B 8/00 (2006.01)

(52) **U.S. Cl.**
CPC **A61B 8/4422** (2013.01); **A61B 8/4281** (2013.01); **A61B 8/4455** (2013.01)

(58) **Field of Classification Search**
CPC combination set(s) only.
See application file for complete search history.

(56) **References Cited**

U.S. PATENT DOCUMENTS

4,617,239 A * 10/1986 Maruyama B41M 5/443
428/452
5,722,412 A * 3/1998 Pflugrath A61B 8/00
600/441
5,738,099 A 4/1998 Chang
(Continued)

FOREIGN PATENT DOCUMENTS

JP 2011083363 4/2011
WO 96-25888 8/1996
WO 2008024515 A2 2/2008

OTHER PUBLICATIONS

Japanese Office Action dated Apr. 28, 2015 for Japanese Application No. 2014-522794.

(Continued)

Primary Examiner — Serkan Akar
Assistant Examiner — Farshad Negarestan
(74) *Attorney, Agent, or Firm* — Anthony M. Del Zoppo, III; Driggs, Hogg, Daugherty & Del Zoppo, Co., LPA

(57) **ABSTRACT**

An ultrasound transducer cover (100) includes a base (202), including an acoustically transmissive membrane (110) with first and second opposing sides. The cover further includes walls (204, 206) protruding from the base in a same direction away from the first side of the base, forming a cavity about the acoustically transmissive membrane with a geometry that conforms to a geometry of a probe head of an ultrasound apparatus housing a transducer array and a corresponding acoustic window. The cover further includes an acoustically transmissive adhesive (108) disposed on the

(Continued)

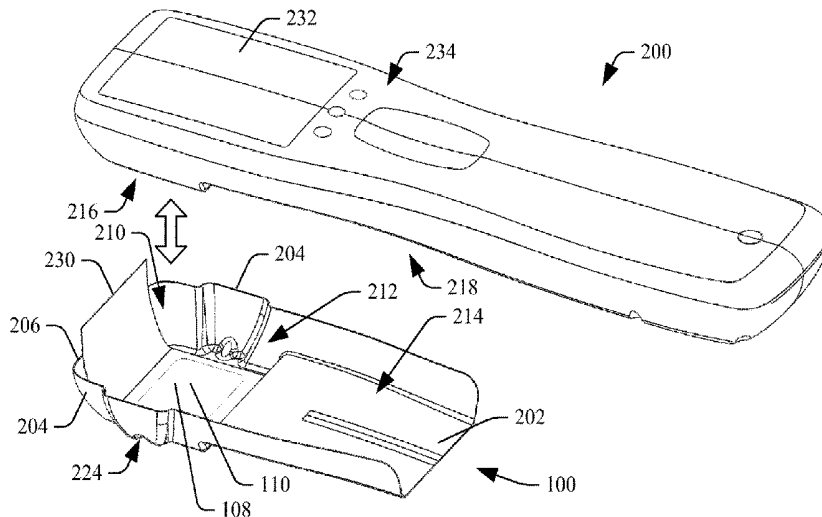

membrane in the cavity, wherein the acoustically transmissive adhesive maintains the cover on the ultrasound apparatus in response to installing the cover on the ultrasound apparatus.

21 Claims, 6 Drawing Sheets

(56)

References Cited

U.S. PATENT DOCUMENTS

5,817,024	A	10/1998	Ogle et al.	
6,048,323	A *	4/2000	Hon	A61B 5/4356 600/588
6,132,378	A	10/2000	Marino	
6,719,699	B2	4/2004	Smith	
2003/0149359	A1	8/2003	Smith	
2006/0030778	A1	2/2006	Mendlein et al.	
2006/0264751	A1	11/2006	Wendelken et al.	
2007/0276241	A1 *	11/2007	Park	A61B 8/00 600/437
2010/0036257	A1	2/2010	Sano et al.	

OTHER PUBLICATIONS

International search report for PCT/IB2011/044978 published as WO 2013/015769 A1.
Bio-Medical Instruments, Inc., 2387 East 8 Mile Road, Warren, MI 48091-2486; bio-medical.com/products/Aquasonic 100 Sterile—48 Overwrapped Foil Pouches.

* cited by examiner

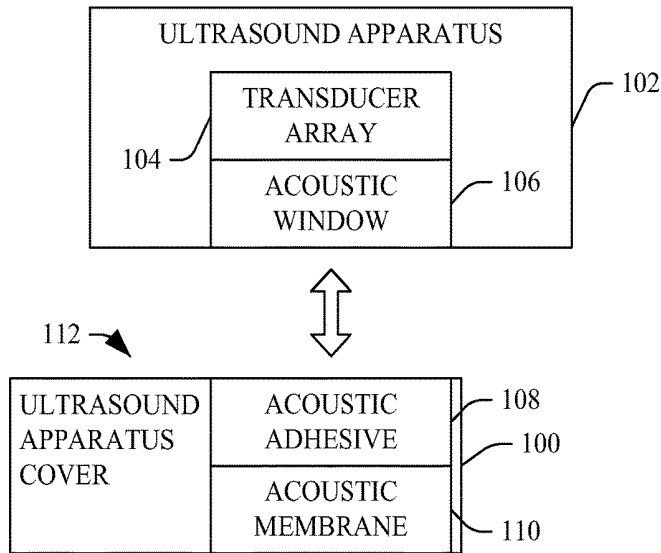

FIGURE 1

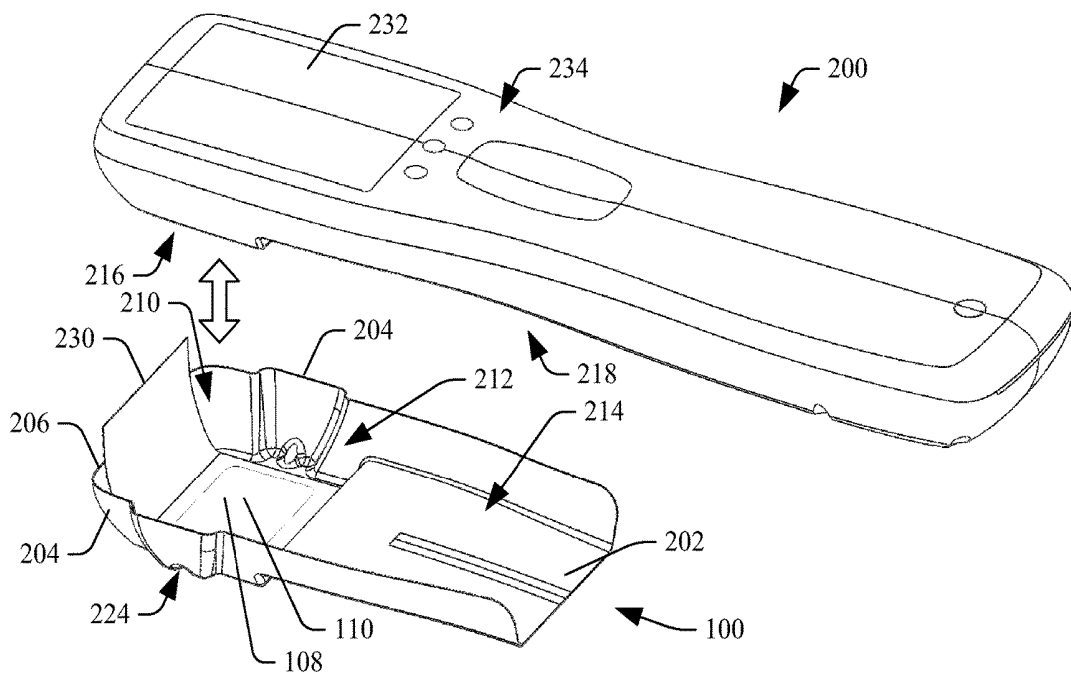

FIGURE 2

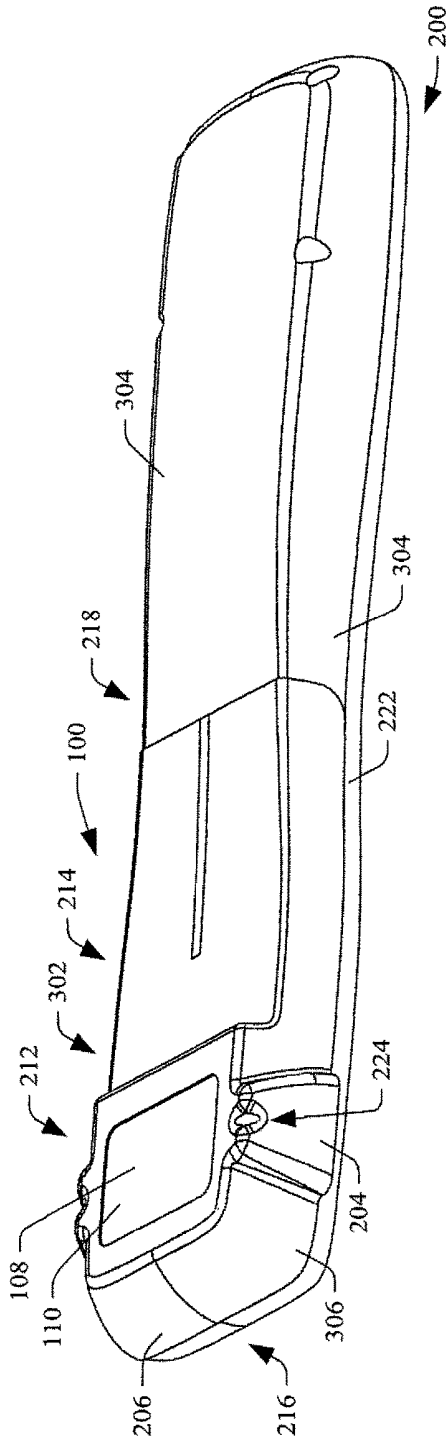

FIGURE 3

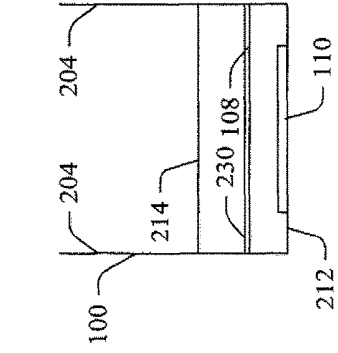

FIGURE 4

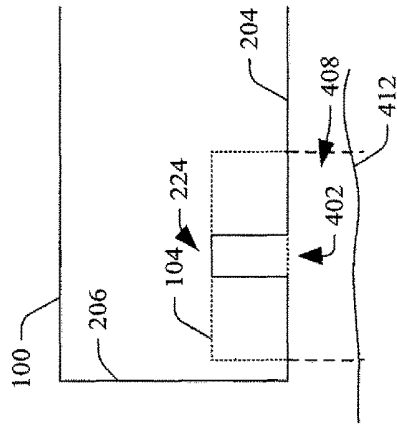

FIGURE 5

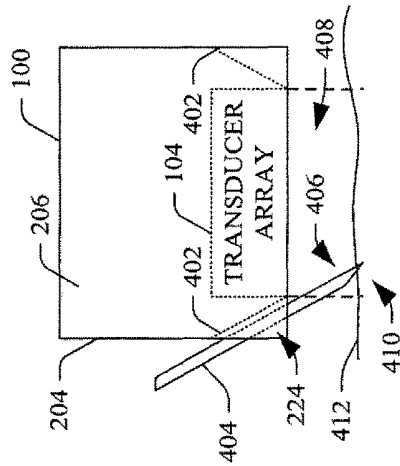

FIGURE 6

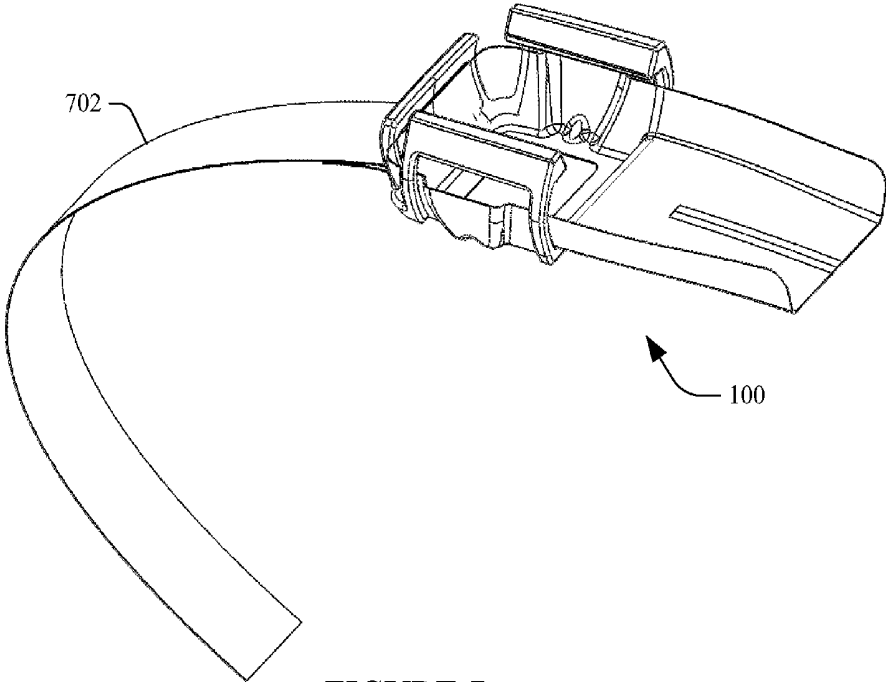

FIGURE 7

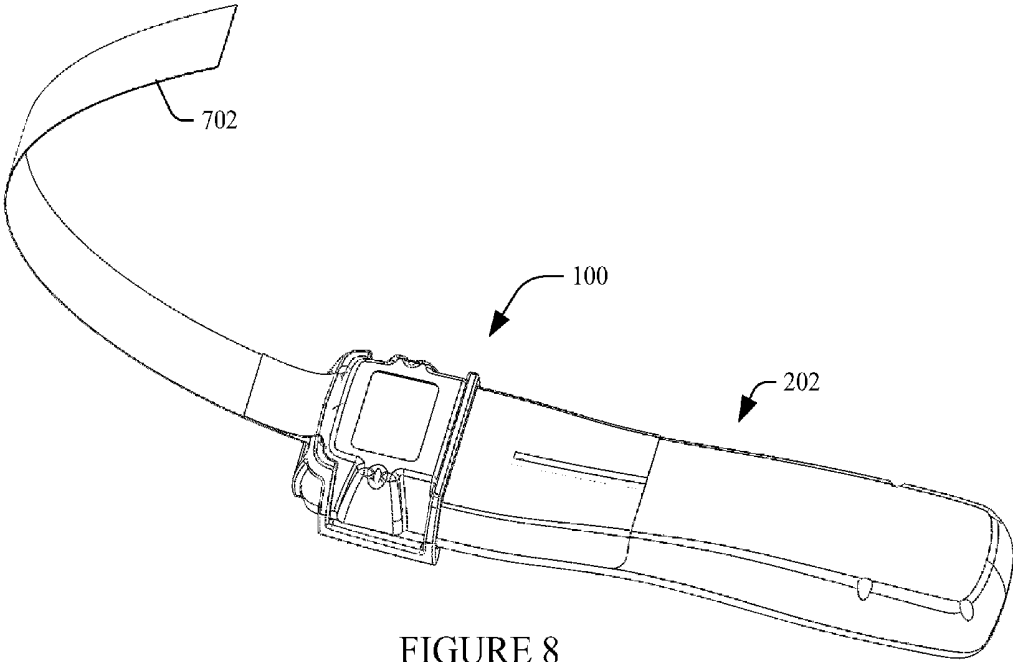

FIGURE 8

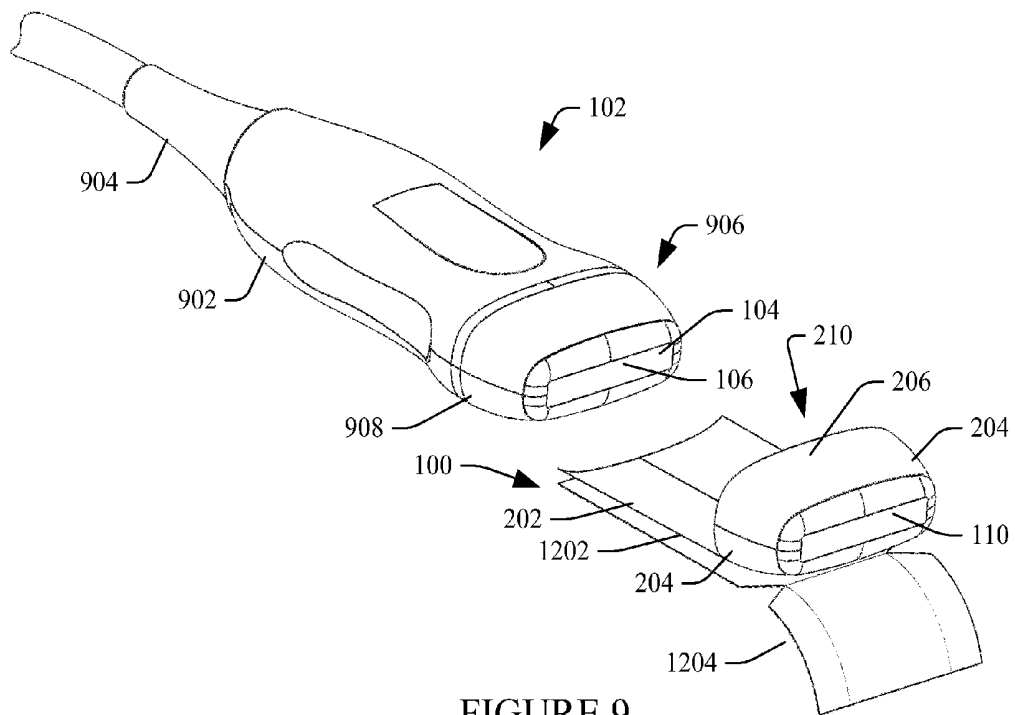

FIGURE 9

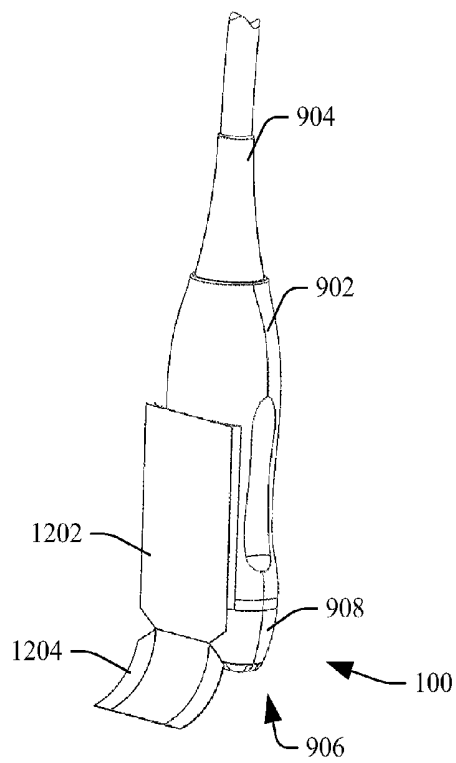

FIGURE 10

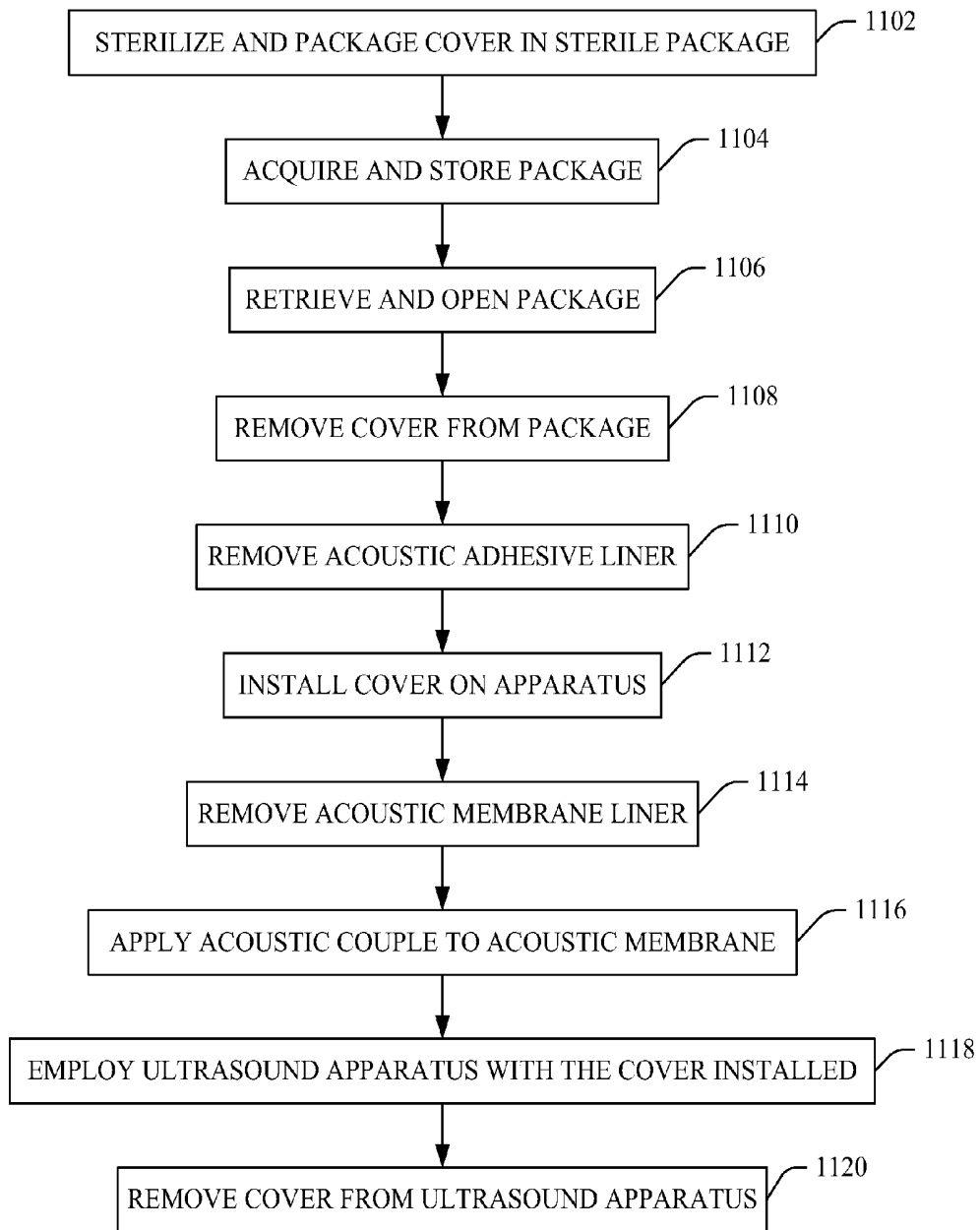

FIGURE 11

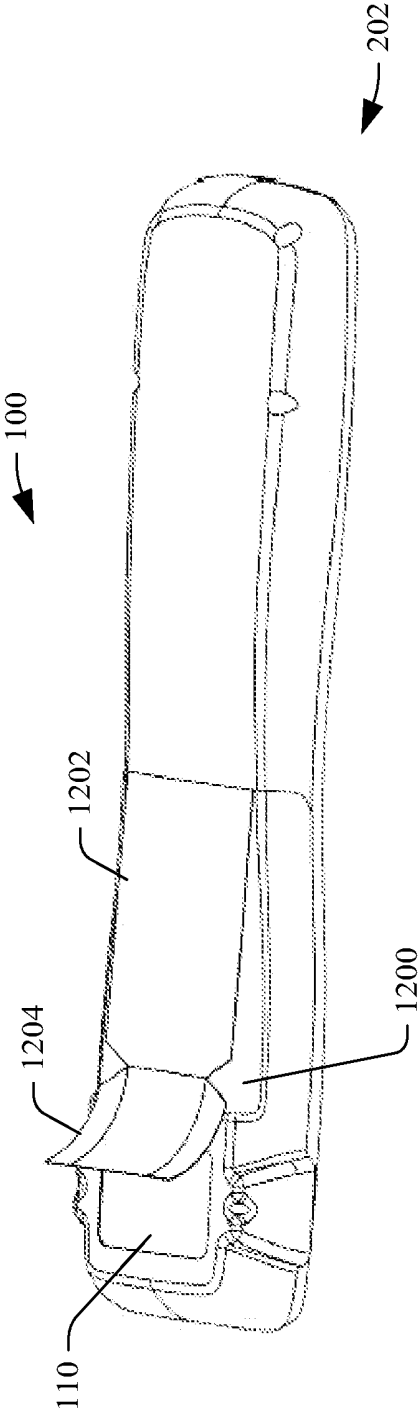

FIGURE 12

ULTRASOUND APPARATUS COVER

RELATED APPLICATION

This application is a national filing of PCT application Serial No. PCT/US2011/044978, filed Jul. 22, 2011, published as WO2013/015769 on Jan. 31, 2013. This application claims priority to PCT application Serial No. PCT/US2011/044978, published as WO2013/015769 on Jan. 31, 2013.

TECHNICAL FIELD

The following generally relates to ultrasound imaging and more particularly to a medical ultrasound transducer array cover.

BACKGROUND

Ultrasound scanners provide useful information about the interior characteristics of an object under examination. In medical applications, clinicians have used ultrasound scanners to examine human subjects in settings such as hospitals, physician's offices, and other locations. Ultrasound scanners have been used in the emergency room, operating room, radiology department, patient room, and/or other environments. In use, an acoustic coupling agent, typically a lubricious gel largely composed of water and propylene glycol, is placed on the acoustic window/lens of the ultrasound transducer array and/or an area of the patient in connection with the region of interest to be scanned. The user then positions the transducer array with respect to the area of the patient. The gel between the acoustic window and the area provides an acoustic medium that facilitates transferring ultrasound signals there between. The ultrasound scanner can then be used to scan the region of interest.

In some environments (e.g., sterile environments), transducer covers are used. Transducer covers conventionally have included a rubber or thin plastic bag or sheath that physically surrounds and encloses the entire or a sub-portion of the probe. When a cover is used an acoustic coupling agent is required both between the transducer and cover and between the cover and the patient. Such covers are supplied sterilized in sterile packaging (e.g., U.S. Pat. No. 3,754,700) and may come prefilled with a coupling gel and/or other coupling agent. Other covers are not pre-filled, and the user adds gel into the bag prior installing on the transducer. The user also applies the gel on the outside of the cover and/or on the area of the patient. Other covers have included cup-shaped covers that snap on the probe (e.g., U.S. Pat. No. 6,132,378) and self-adhesive thin pliable film dressings that are wrapped around and adhere to the probe (e.g., U.S. 2006/0264751 A1). Unfortunately, such covers can be cumbersome to install and use.

Procedures such as biopsies, peripheral intravenous insertions (PIVs), and/or other procedures which involve use of a needle entail employing a separate needle guide apparatus with the probe or a needle guide accessory that attaches to the probe. Generally, such needle guides have been configured to constrain a needle in a fixed path (plane and/or insertion angle), for example, that is in the middle of elevation of the acoustic beam (traditional single plane transducer) represented by a guide line on the ultrasound system. A typical needle guide has two main components: a reusable bracket that snaps on the probe and is placed under the cover (where a cover is used), and a disposable guide that attaches from outside the cover. Unfortunately, such assem-

bly may not be easy to install and may require more than one person to maintain sterility during cover and/or needle guide installation in a sterile environment, and may be too restrictive for PIV. Furthermore, for certain procedures such as peripheral intravenous insertions, the size of the sterile field is limited to a small area directly around the insertion site and a cover that encloses the entire transducer may provide more coverage than is required. Moreover, traditional ultrasound gel is not well-suited for ultrasound guided peripheral intravenous insertions, for example, because of post needle insertion cleanup in preparation for application of dressings over the catheter.

SUMMARY

Aspects of the application address the above matters, and others.

In one aspect, an ultrasound transducer cover includes a base, including an acoustically transmissive membrane with first and second opposing sides. The cover further includes walls protruding from the base in a same direction away from the first side of the base, forming a cavity about the acoustically transmissive membrane with a geometry that conforms to a geometry of a probe head an ultrasound apparatus housing a transducer array and a corresponding acoustic window. The cover further includes an acoustically transmissive adhesive disposed on the base in the cavity. The acoustically transmissive adhesive maintains the cover on the ultrasound apparatus in response to installing the cover on the ultrasound apparatus.

In another aspect, a method includes obtaining an ultrasound transducer cover. The cover includes a base with an acoustically transmissive membrane with first and second opposing sides. The cover further includes walls protruding from the base in a same direction away from the first side of the base, forming a cavity about the acoustically transmissive membrane with a geometry that conforms to a geometry of a probe head an ultrasound apparatus housing a transducer array and a corresponding acoustic window. The cover further includes an acoustically transmissive adhesive disposed on the base in the cavity. The cover further includes an adhesive liner removeably affixed to the acoustically transmissive adhesive. The method further includes removing the adhesive liner from the acoustically transmissive adhesive. The method further includes installing the cover on the probe head by physically contacting the acoustically transmissive adhesive with the acoustically transmissive window of the ultrasound apparatus. The acoustically transmissive adhesive maintains the cover on the ultrasound apparatus in response to installing the cover on the ultrasound apparatus.

In another aspect, a method includes obtaining an ultrasound transducer cover. The cover includes a base with an acoustically transmissive membrane with first and second opposing sides. The cover further includes walls protruding from the base in a same direction away from the first side of the base, forming a cavity about the acoustically transmissive membrane with a geometry that conforms to a geometry of a probe head an ultrasound apparatus housing a transducer array and a corresponding acoustic window. The cover further includes an acoustically transmissive adhesive disposed on the base in the cavity. The method further includes installing a removable adhesive liner to cover the acoustically transmissive adhesive. The method further includes packaging the cover with the liner in a container.

Those skilled in the art will recognize still other aspects of the present application upon reading and understanding the attached description.

BRIEF DESCRIPTION OF THE DRAWINGS

The application is illustrated by way of example and not limitation in the figures of the accompanying drawings, in which like references indicate similar elements and in which:

FIG. 1 schematically illustrates an example cover for an ultrasound apparatus;

FIGS. 2 and 3 illustrate an example cover for a hand held single enclosure ultrasound scanner;

FIGS. 4 and 5 illustrate an example needle guide of the cover;

FIG. 6 illustrates an example in which the cover includes an acoustically transmissive adhesive with a removable liner;

FIGS. 7 and 8 illustrate a variation of the cover of FIGS. 2 and 3 in which the cover includes a strap for holding the transducer in place on a patient;

FIGS. 9 and 10 illustrate an example cover for a probe configured to be connected to an ultrasound scanner console via a cable;

FIG. 11 illustrates an example method for the cover; and

FIG. 12 illustrates an optional integrated gel dispense and an optional liner for covering the outside of the acoustically transmissive membrane.

DETAILED DESCRIPTION

FIG. 1 schematically illustrates an ultrasound apparatus cover **100** in connection with an ultrasound apparatus **102**. In this example, the ultrasound apparatus **102** includes at least a transducer array **104** and an acoustic window/lens **106** located at a region of the ultrasound apparatus **102** configured to be placed in contact with an object or structure to scan a portion of the object or structure. As described in greater detail below, the ultrasound apparatus **102** may be part of a single enclosure hand held ultrasound scanner, a transducer probe configured to connect to a separate ultrasound console via a cable or the like, and/or other ultrasound apparatus **102**.

The ultrasound apparatus cover **100** includes an acoustically transmissive membrane **110** and an acoustically transmissive adhesive **108**, which is affixed thereto. The acoustically transmissive membrane **110** can include a plastic, a rubber and/or other material, including, but not limited to, a water based or an alcohol based liquid or gel, and/or a semi-rigid pad. In one embodiment, the acoustically transmissive membrane **110** provides a barrier that inhibits pathogens from migrating from one side of the membrane to the other side. The acoustically transmissive adhesive **108** is located in connection with a first side **112** of the ultrasound apparatus cover **100**, and the acoustically transmissive membrane **110** is located adjacent thereto and in connection with a second opposing side **114** of the ultrasound apparatus cover **100**, which opposes the first side **112**. The acoustically transmissive adhesive **108** can be any type of adhesive with suitable acoustic coupling characteristics such as alcohol, water, oil, etc. based and/or other acoustically transmissive adhesive in the form of a liquid, a gel, a semi-rigid gel pad, a tape, a rigid material, and/or other form. The acoustically transmissive adhesive **108** and the acoustically transmissive membrane **110** are arranged with respect to each other in the ultrasound apparatus cover **100** such that the acoustically

transmissive adhesive **108** and the acoustically transmissive membrane **110** are in mechanical contact and acoustically coupled.

The ultrasound apparatus cover **100** is generally rigid and pre-formed (e.g., thermo, injection mold, or otherwise formed) so that the first side geometrically conforms to a shape of at least a portion of the ultrasound apparatus **102** that includes the acoustic window/lens **106**, before and after installing the cover **100** on the apparatus **102**. In one instance, this includes configuring at least the shape of the ultrasound apparatus cover **100** so that the acoustically transmissive adhesive **108** and acoustically transmissive membrane **110** are positioned to align with the acoustic window **106** and hence the transducer array **104** when the cover **100** is installed on the apparatus **102**. Suitable cover materials include plastic, cardboard, paper, metal, and/or other materials. In one instance, the material has a thickness in a range of about five thousandths of an inch to about forty thousandths of an inch such as twenty thousandths of an inch. Where the cover material includes a cardboard, paper or the like, the cover **100** can be laminated, coated and/or otherwise protected with a water resistant material. Optionally, the base, walls and acoustically transmissive membrane are monolithic and made of a thermoplastic material.

The acoustically transmissive adhesive **108**, when placed in physical contact with the ultrasound apparatus **102**, adheres to the acoustic window/lens **106** of the ultrasound apparatus **102**, maintaining installation of the cover **100** with the apparatus **102**. The acoustically transmissive adhesive **108** and the acoustically transmissive membrane **110** are arranged in the ultrasound apparatus cover **100** so that acoustically transmissive membrane **110** aligns with the acoustic window/lens **106** when the cover **100** is installed on the apparatus **102**. In such a configuration, the acoustically transmissive adhesive **108** and the acoustically transmissive membrane **110** provide an acoustic medium between the transducer array **104** and the portion of the object or subject being scanned. In one instance, the acoustically transmissive adhesive **108** can be any suitable adhesive strength that allows the cover **100** to stay in place during use for scanning, but for purposes of disposal of the cover, is reasonably easily to release without damage to the ultrasound apparatus **102** or acoustic window/lens **106**.

The ultrasound apparatus cover **100** may be disposable, cleanable, disinfectable, re-usable, and/or sterilizable. Where the ultrasound apparatus cover **100** is disinfected and/or sterilized, the ultrasound apparatus cover **100** may provide a sonographer or other user of the ultrasound apparatus **102** a quick way of rendering the side **106** of the ultrasound apparatus **102** sterile. In this instance, the ultrasound apparatus cover **100** may also be packaged in a sterile package.

Optionally, the ultrasound apparatus cover **100** includes physical features for various functions such as to guide a needle for needle access procedures such as biopsies or peripheral IV line placements, to secure the ultrasound apparatus **102** in a desired position without human intervention, to apply an acoustic couplant between the cover **100** and the patient for scanning, and/or other physical features.

FIGS. 2 and 3 illustrate a non-limiting example of the ultrasound apparatus cover **100** where the ultrasound apparatus **102** includes an ultrasound scanner **200** configured as a hand held single enclosure. In FIG. 2, the cover **100** is not installed on the ultrasound scanner **200**, and in FIG. 3 the cover **100** is installed on the ultrasound scanner **200**.

Initially referring to FIG. 2, the cover **100** includes a base **202**, first and second opposing side walls **204**, and a front

wall 206. The walls 204 and 206 protrude from the base 202 in a same direction, thereby forming an open cavity 210 defined by the base 202 and the walls 204 and 206, with an open side, which opposes the front wall 206, and an open side, which opposes the base 202.

A first portion 212 of the base 202 is located adjacent to the front wall 206 and a second portion 214 of the base 202 extends from the first portion 212 in a direction away from the front wall 206. The first portion 212 is recessed with respect to the second portion 212 and includes the acoustically transmissive membrane 110.

The first portion 212 has a geometrical shape that conforms substantially to a shape of a probe head 216 of the ultrasound scanner 200, which houses the transducer array 104 and acoustic window 106 (FIG. 1). The second portion 214 has a geometrical shape that conforms substantially to a shape of a handle portion 218 of the ultrasound scanner 200. In this embodiment, a length of the second portion 214 is less than a length of the handle portion 218. In other embodiments, the length of the second portion 214 can be larger or smaller, or the second portion 214 can be omitted.

A removable liner 230 is located in the cavity 210 and is used to cover the acoustically transmissive adhesive 108. The liner 230 is removed before installing the ultrasound apparatus cover 100 on the ultrasound scanner 200. In FIG. 2, the removable liner 230 is shown extending past the front wall 206 to enable easy grasping by the user. In this embodiment the liner 230 is completely removed from the cover 100. In other embodiments the liner could be folded to a position where it does not interfere with scanning with the ultrasound scanner 200.

FIG. 3 shows the cover 100 from a backside 302 of the base 202, which faces away from the cavity 210. As shown in FIG. 3, the walls 204 cover side walls 304 of the ultrasound scanner 200, the front wall 206 covers a front wall 306 of the ultrasound scanner 200, the first portion 212 of the base 202 rests against the probe head 216, the second portion 214 of the base 202 rests against the handle portion 218, and the acoustically transmissive membrane 110 adheres to the window portion 106 of the probe head 216 of the ultrasound scanner 200 via the acoustically transmissive adhesive 108.

In FIGS. 2 and 3, the cover 100 also includes a needle guide 224, which is located in connection with the walls 204. For sake of clarity, the needle guide 224 is discussed in connection with FIGS. 4 and 5, which respectively show a block diagram representation of the ultrasound apparatus cover 100 looking into the front wall 206 (FIG. 4) and looking into one of the side walls 204 (FIG. 5).

In FIGS. 4 and 5, the needle guide 224 includes a channel 402 which is configured to guide (e.g., provide a centerline), but not constrain, a needle 404 along a path for freehand or other insertion. The channel 402 is configured so that a tip region 406 of the needle 404 can be readily positioned in an imaging region 408 of the transducer array 104 between the transducer array 104 and a region 410 of a subject 412 where the needle is inserted. With a conventional single plane transducer, this may include guiding the needle 404 in the middle of elevation of the imaging region 408.

FIG. 4 shows a configuration with two needle guides 224, one on each of the two side walls 204. Other embodiments may include no, one, or more than two needle guides 224. In yet another embodiment, a needle guide 224 is additionally or alternatively located with respect to the front wall 206 and/or other location. Note that the size, shape and relative position of the components in FIGS. 4 and 5 are for explanatory purposes and are not limiting.

With continuing reference to FIGS. 2 and 3 and with reference to FIG. 6, a block diagram looking into the front wall 206 of the cover 100 and showing the acoustically transmissive adhesive 108 in the first portion 212 is illustrated. In this embodiment, the acoustically transmissive adhesive 108 is a pre-applied liquid or gel acoustic adhesive. In another instance, the acoustically transmissive adhesive 108 is a semi-rigid double-sided adhesive gel pad. In yet another instance, the acoustically transmissive adhesive 108 includes a plurality of sheets material. The liner 230 is shown removeably affixed over the acoustically transmissive adhesive 108 and is removed before installing the cover 100 on the ultrasound scanner 200.

In FIGS. 2 and 3, the ultrasound scanner 200 is a hand held ultrasound scanner housed in a single enclosure. As such, the scanner 200 includes, in addition to the transducer array 104, a transducer array controller (not visible), an image processor (not visible), a display 232, and a user interface 234. The transducer array 104 includes a one-dimensional and/or a two-dimensional array of transducer elements arranged in a linear, curved, circular, or other manner, and is configured to acquire data for A-mode, B-mode, C-mode, etc. acquisitions, individually and in combination with color flow, Doppler flow, and/or other information.

The transducer array controller includes transmit and receive circuitry and a switch that switches between transmit and receive circuitry. Generally, the transmit circuitry controls actuation of the transducer elements, which allows for steering and/or focusing the transmitted beam from predetermined origins along the array and at predetermined angles, and the receive circuitry's various processes receive echoes and generates and outputs a processed signal. In one non-limiting instance, the receive circuitry delays and sums received echoes, generating a focused signal for a single line through a scanned region of interest. Other suitable processing includes, but is not limited to, spatial compounding, filtering (e.g., FIR, IIR, etc.), and/or other processing.

The image processor includes one or more processors that convert the signal from the transducer controller to generate data for display, for example, by converting the data to the coordinate system of the display. The display 232 can be used to present the converted data. By way of non-limiting example, in one mode, the display can present a plane of a vessel that is parallel to a bottom or transducer array and that shows the interior of the vessel along the long axis of the vessel, including a portion of the needle 404 within the displayed interior of the vessel, when the needle 404 is inserted into the vessel.

The user interface 234 includes various input and/or output devices for interacting with the transducer controller, for example, to select a data processing and presentation mode, a data acquisition mode, initiate scanning, etc. The user interface 234 may include various controls such as buttons, knobs, a keypad, a touch screen, etc. The user interface 234 may also include various types of visual (e.g., LCD, LED, etc.) and/or audible feedback.

Variations and/or other embodiments are contemplated.

FIG. 12 shows an embodiment in which the ultrasound apparatus cover 100 also includes a support region 1200 where a packet 1202 of acoustic coupling material can be removeably affixed. Various approaches can be used to affix the packet 1202 to the support region 1200. For example, an adhesive may be applied to the region 1200 and/or the packet 1202, and this adhesive can be used to affix the packet 1202 to the region 1200. In another example, the region 1200 may include a pocket in which the packet 1202 can be

inserted into. Other approaches are also contemplated herein. In the illustrated embodiment, a removable tab **1204** is torn off and removed prior to the packet **1202** being squeezed to apply an acoustic coupling material to the exterior of acoustic membrane **110**. In another embodiment, the support **1200** and packet **1202** are omitted, and an acoustic couplant such as a hydrogel pad is integrated with the membrane **110**.

In another embodiment, the removable tab **1204** additionally comprises a removable sterile liner **1204** that covers surfaces that are intended to remain sterile such as the acoustic membrane **110** of the side that contacts the patient. The liner **1204** can be removed before, during or after installing the ultrasound apparatus cover **100** on the ultrasound scanner **200**, but before scanning. In FIG. **12**, the removable liner **1204** is shown partially folded back and partially removed. The liner **1204** can be completely removed from the cover **100** or folded to a position where it does not interfere with scanning with the ultrasound scanner **200**. In another embodiment this sterile liner **1204** may be a separate feature from the packet **1202** and/or there may be no packet.

FIGS. **7** and **8** show a variation in which the ultrasound apparatus cover **100** further includes a strap **702**. In this example, the strap **702** is affixed at the front wall **206** of the cover **100**. In other embodiments, the strap **702** can be elsewhere affixed to the cover **100**. The strap **702** can include various materials such as rubber, plastic, leather, etc. The strap **702** can be used for various reasons. For example, in one instance the strap **702** is used to secure the ultrasound scanner **200** in position with respect to the region of the subject or object being scanned. This may include wrapping or tying the strap around a fixture or device in the examination room. In this manner, the user of the ultrasound scanner **200** does not have to hold the ultrasound scanner **200** in position. This allows, for example, the user of the ultrasound scanner **200** to free up his hands, for example, so that the user can use both hands to insert a needle into the subject or object.

FIGS. **9** and **10** illustrate a non-limiting example in which the ultrasound apparatus **102** is a conventional ultrasound probe **902** that connects to a separate ultrasound console via an electrical cable interface **904**. This cable interface may or may be detachable from the console via an electrical connector. In this instance, the console includes the transducer array controller, the image processor, the display and a user interface. With the illustrated probe **902**, the transducer array **104** is located at an end **906** of the probe head **908**.

In this embodiment, the second portion **214** of the base **202** extends in the same direction as the walls **204** and **206**, and the open cavity **210** is defined by the first and second portions **214** and **214** of the base **202** and the walls **204** and **206**, with only the open side that opposes the base **202**. Likewise, the cover **100** is rigid and the cavity **210** is pre-formed and geometrically configured based on the geometry of the probe head **908**. Furthermore, the acoustically transmissive adhesive **108** (not visible) is in the cavity **210** next to the acoustically transmissive membrane **110** and adheres to the acoustic window **104** when the cover **100** is installed on the probe **902**, maintaining installation.

In this embodiment, the cover **100** also includes the packet of acoustic material **1202** affixed thereto which is discussed at least in connection with FIGS. **2** and **3**. In another instance, the packet **1204** is omitted. Unlike cover **100** in FIGS. **2** and **3**, the cover **100** in this embodiment does not include the needle guide **224** or the strap **702**. However, in other embodiments, the cover **100** for the probe **902** also

includes at least one of needle guide **224** or the strap **702**. Additionally or alternatively, a separate needle guide can be employed with the probe **902**.

Although two types of ultrasound apparatuses **102** are shown (FIGS. **2** and **3** and FIGS. **9** and **10**), it is to be understood that other types of ultrasound apparatuses **102** are also contemplated herein. In such other instance, the apparatus cover **100** can be configured based on the geometry of the particular ultrasound apparatus **102**, in accordance to the description herein and/or variants thereof. Moreover, in such instances one or more of the features (e.g., needle guide, strap, acoustic couplant dispenser, etc.) described herein can be included.

It is to be appreciated that the cover **100** can be sterilized and packaged for use in sterile environments and used in such an environment. FIG. **11** illustrates an example method of this.

It is to be understood that the following acts are provided for explanatory purposes and are not limiting. As such, one or more of the acts may be omitted, one or more acts may be added, one or more acts may occur in a different order (including simultaneously with another act), etc.

At **1102**, the cover **100** is sterilized and placed in sterilizable package, which is sealed and sterilized. This can be achieved by a manufacturer and/or any appropriate sterilization method (e.g., EtO, Gamma Ray, etc.).

At **1104**, the package is acquired by a health care facility and stored in a location that won't compromise the sterility of the cover **100**.

At **1106**, the package is retrieved and opened in a sterile environment.

At **1108**, the cover **100** is removed from the sterile package. This can be done via authorized personnel wearing sterile clothes, where the cover **100** is handled so as not to breach its sterility.

At **1110**, the inside adhesive liner **230** is removed. In instances where the cover **100** does not include the liner **230**, this act is omitted.

At **1112**, the cover **100** is installed on the ultrasound apparatus **102**. As described herein, this includes physically contacting the acoustically transmissive adhesive **108** with the acoustic window **106** of the ultrasound apparatus **102**, where the acoustically transmissive adhesive **108** holds the cover **100** in place.

At **1114**, the outside acoustically transmissive membrane liner **1204** is removed. In instances where the cover **100** does not include the liner **1204**, this act is omitted.

At **1116**, the packet **1202** is used to apply a sterile acoustic couplant on the acoustically transmissive membrane **110**. In instances where the cover **100** does not include the packet **1202**, the sterile acoustic couplant can be manually applied from a separate bottle/packet to the acoustically transmissive membrane **110** and/or object or subject.

At **1118**, the ultrasound apparatus **102** with the cover **100** installed thereon is used to perform an ultrasound procedure.

At **1120**, subsequent to imaging with the apparatus **102**, the cover **100** is removed from the ultrasound apparatus **102** and discarded or alternatively cleaned, disinfected, sterilized, etc.

The application has been described with reference to various embodiments. Modifications and alterations will occur to others upon reading the application. It is intended that the invention be construed as including all such modifications and alterations, including insofar as they come within the scope of the appended claims and the equivalents thereof.

What is claimed is:

1. A rigid and pre-formed ultrasound apparatus cover for a hand held single enclosure ultrasound scanner that includes a probe head with at least a transducer array and a corresponding acoustic window, an image processor, a user interface and a display, the rigid and pre-formed ultrasound apparatus cover comprising:

a base:

first and second opposing side walls: and

a front wall,

wherein the first, second and front walls protrude from the base in a same direction forming an open cavity defined by the base and the first, second and front walls, with an open side, which opposes the front wall, and an open side, which opposes the base,

wherein the base includes a first portion adjacent to the front wall and a second portion extending from the first portion in a direction away from the front wall,

wherein the front wall includes a first end and a second opposing end,

wherein the first side wall has a first end and is transverse to the front wall, and the first end of the first side wall meets the first end of the front wall, and the second side wall has a first end and is transverse to the front wall, the first end of the second side wall meets the second end of the front wall,

wherein at least one of the first or second walls includes at least one channel configured to guide a needle being inserted into a region of an object or subject;

an acoustically transmissive membrane with first and second opposing sides, wherein the acoustically transmissive membrane is disposed on the first portion of the base; and

an acoustically transmissive adhesive disposed on the acoustically transmissive membrane in the open cavity.

2. The rigid and pre-formed ultrasound apparatus cover of claim 1, wherein the acoustically transmissive adhesive provides an acoustic medium for transmission of ultrasound signals between the acoustic window of the hand held single enclosure ultrasound scanner and the acoustically transmissive membrane of the rigid and pre-formed ultrasound apparatus cover.

3. The rigid and pre-formed ultrasound apparatus cover of claim 1, wherein the acoustically transmissive membrane includes a plastic or rubber film.

4. The rigid and pre-formed ultrasound apparatus cover of claim 1, wherein the acoustically transmissive membrane includes one of a water based or an alcohol based liquid or gel.

5. The rigid and pre-formed ultrasound apparatus cover of claim 1, wherein the acoustically transmissive membrane includes a semi-rigid pad.

6. The rigid and pre-formed ultrasound apparatus cover of claim 1, wherein the first portion of the base is recessed in the base relative to the second portion of the base.

7. The rigid and pre-formed ultrasound apparatus cover of claim 1, wherein the base and the first and second walls are configured to receive the probe head of the hand held single enclosure ultrasound apparatus.

8. The rigid and pre-formed ultrasound apparatus cover of claim 7, wherein the second portion of the base includes a non-acoustically transmissive membrane region and is configured to receive a handle portion of the hand held single enclosure ultrasound apparatus.

9. The rigid and pre-formed ultrasound apparatus cover of claim 1, wherein the front, the first, and the second walls form a closed wall around the acoustically transmissive membrane.

10. The rigid and pre-formed ultrasound apparatus cover of claim 1, wherein the channel guides the needle through a region located between the acoustically transmissive membrane and the region of an object or subject.

11. The rigid and pre-formed ultrasound apparatus cover of claim 1, wherein the base includes a cardboard or paper material.

12. The rigid and pre-formed ultrasound apparatus cover of claim 11, wherein the base material is laminated or coated with a water resistant material.

13. The rigid and pre-formed ultrasound apparatus cover of claim 1, wherein the base includes an injection molded material or thermoformed thermoplastic material.

14. The rigid and pre-formed ultrasound apparatus cover of claim 1, wherein the base, the front, first and second walls, and the acoustically transmissive membrane are monolithic and comprise a thermoplastic material.

15. The rigid and pre-formed ultrasound apparatus cover of claim 1, further comprising:

an adhesive liner that is removeably affixed next to and covers a surface of the acoustically transmissive adhesive, and the adhesive liner faces towards the acoustically transmissive membrane and into the cavity.

16. The rigid and pre-formed ultrasound apparatus cover of claim 1, wherein the acoustically transmissive adhesive is releasable from the hand held single enclosure ultrasound scanner after use.

17. The rigid and pre-formed ultrasound apparatus cover of claim 1, further comprising:

a strap configured to be secured to a static structure to maintain the rigid and pre-formed ultrasound apparatus cover, and hence the hand held single enclosure ultrasound scanner, at a static position without human intervention.

18. The rigid and pre-formed ultrasound apparatus cover of claim 1, further comprising:

a support region configured to support a container of an acoustic coupling medium.

19. The rigid and pre-formed ultrasound apparatus cover of claim 18, wherein the container is configured to dispense the acoustic coupling medium onto the acoustically transmissive membrane.

20. The rigid and pre-formed ultrasound apparatus cover of claim 1, wherein the rigid and pre-formed ultrasound apparatus cover is a sterilized rigid and pre-formed ultrasound apparatus cover and is disposed in a sterile kit.

21. The rigid and pre-formed ultrasound apparatus cover of claim 1, wherein the acoustically transmissive membrane provides a barrier that inhibits pathogens from migrating from the first to the second opposing sides.

* * * * *

专利名称(译)	超声仪器盖		
公开(公告)号	US9980700	公开(公告)日	2018-05-29
申请号	US14/234063	申请日	2011-07-21
[标]申请(专利权)人(译)	gubbini亚历山德罗 NELSON BRADLEY		
申请(专利权)人(译)	GUBBINI , ALESSANDRO NELSON , BRADLEY		
当前申请(专利权)人(译)	音效技术 , INC.		
[标]发明人	GUBBINI ALESSANDRO NELSON BRADLEY		
发明人	GUBBINI, ALESSANDRO NELSON, BRADLEY		
IPC分类号	A61B8/00		
CPC分类号	A61B8/4422 A61B8/4455 A61B8/4281		
其他公开文献	US20140163382A1		
外部链接	Espacenet USPTO		

摘要(译)

超声换能器盖 (100) 包括基部 (202) , 包括具有第一和第二相对侧的声透射膜 (110) 。盖子还包括从基座沿远离基座的第一侧的相同方向突出的壁 (204,206) , 形成围绕声透射膜的腔, 其具有符合几何形状的几何形状。容纳换能器阵列和相应声学窗口的超声设备的探头的一部分。盖子还包括设置在腔体中的膜上的声透射粘合剂 (108) , 其中声学透射粘合剂响应于将盖子安装在超声设备上而将盖子保持在超声设备上。

